



HAL
open science

Predictive capabilities of data-driven machine learning techniques on wave-bridge interactions

Deming Zhu, Jiaxin Zhang, Qian Wu, You Dong, Emilio Bastidas-Arteaga

► **To cite this version:**

Deming Zhu, Jiaxin Zhang, Qian Wu, You Dong, Emilio Bastidas-Arteaga. Predictive capabilities of data-driven machine learning techniques on wave-bridge interactions. *Applied Ocean Research*, 2023, 137, pp.103597. 10.1016/j.apor.2023.103597 . hal-04113301

HAL Id: hal-04113301

<https://hal.science/hal-04113301v1>

Submitted on 1 Jun 2023

HAL is a multi-disciplinary open access archive for the deposit and dissemination of scientific research documents, whether they are published or not. The documents may come from teaching and research institutions in France or abroad, or from public or private research centers.

L'archive ouverte pluridisciplinaire **HAL**, est destinée au dépôt et à la diffusion de documents scientifiques de niveau recherche, publiés ou non, émanant des établissements d'enseignement et de recherche français ou étrangers, des laboratoires publics ou privés.

Predictive capabilities of data-driven machine learning techniques on wave-bridge interactions

Deming Zhu¹, Jiaxin Zhang¹, Qian Wu^{1,2}, You Dong^{1,3*}, Emilio Bastidas-Arteaga⁴

To explore coastal bridge safety subjected to extreme waves during coastal natural hazards, numerical simulations that combine finite element methods and experimental data have been recognized as effective in computing wave-induced loads on coastal bridges. However, the structural design and performance assessment for bridge networks require laborious efforts and massive computational resources to account for uncertain scenarios. To provide reliable wave force estimation tools and facilitate the associated risk assessment, this study performs a hydrodynamic experiment on the wave-bridge interactions and develops data-driven Long-Short-Term-Memory (LSTM) Machine Learning (ML) models for time series forecasting of wave forces. Specifically, a 1:30 scale bridge superstructure specimen is used for the wave test in the wave channel. Different solitary wave and regular wave conditions are tested. Time histories of wave profiles, wave-induced forces, and pressures are measured and served as a dataset basis for the training of LSTM models. High-performance LSTM prediction models are developed through the tuning of different hyperparameters. The well-trained models have high accuracy and could predict the wave force time series based on the excitation wave profiles in seconds. It is envisioned that LSTM models could provide more reliable estimations with the development based on more data sources, providing a fast path for structural design, analysis, and maintenance.

Keywords: Coastal bridge; Hydrodynamic experiment; Wave force prediction; LSTM; Machine learning

¹ Department of Civil and Environmental Engineering, The Hong Kong Polytechnic University, Hong Kong, China.

² Department of Ocean Science and Engineering, Southern University of Science and Technology, Shenzhen, China.

³ Research Institute for Sustainable Urban Development, The Hong Kong Polytechnic University, Hong Kong, China

⁴ Department of Civil Engineering, La Rochelle University, France

* Corresponding Author: you.dong@polyu.edu.hk.

32 **1. Introduction**

33 As an essential component of transportation systems in nearshore cities, the safety of coastal
34 bridges is often threatened by the hostile natural environment. Due to the increasing hazard
35 intensity and sea level rise caused by global climate change, tropical cyclone and tsunami-
36 induced waves have resulted in severe damage to low-lying bridges in recent decades.
37 According to the post-hazard survey, Hurricane Ivan in 2004 was responsible for 58 bridge
38 span damages being unseated from the piers and 66 spans being misaligned (Meng and Jin
39 2007). In the next year, Hurricane Katrina caused severe damage to coastal bridges once again,
40 including the US 90 highway bridge over Biloxi Bay, the US 90 highway bridge over Bay St.
41 Louis, and a box-girder railroad bridge (Robertson et al. 2011). The deck unseating failure,
42 which refers to the unexpected bridge span fall under extreme wave impacts, has been
43 recognized as one of the critical failure modes of coastal bridges (Ataei and Padgett 2013;
44 Azadbakht and Yim 2016; Robertson et al. 2007). This has motivated a number of studies to
45 assess the magnitudes of wave loads and bridge damage mechanisms in past years.

46 To date, a series of physical tests have been carried out to study the huge wave forces
47 acting on bridge spans (Guo et al. 2016; Istrati and Buckle 2019; Qu et al. 2018; Seiffert et al.
48 2014; Seiffert et al. 2015; Zhang et al. 2020), but an accurate estimation method has not been
49 promoted. Motivated by the extensive coastal bridge damages during Hurricane Ivan in 2004
50 and Hurricane Katrina in 2005, Douglass et al. (2006) conducted a large-scale test to investigate
51 periodic wave-induced forces on a bridge span and proposed some basic empirical formulas to
52 estimate the maximum vertical and horizontal wave forces. Bradner et al. (2011) measured the
53 wave loads on a 1:5 scale reinforced concrete model of the I-10 type bridge span and
54 investigated the effects of different wave parameters. Cuomo et al. (2009) reported their
55 experimental studies on a 1:10 scale bridge model and pointed out the adverse effects due to
56 the trapped air beneath the deck. Although the first guideline for estimating wave forces acting
57 on the coastal bridges was then published based on the physics-based method (AASHTO 2008),
58 several key factors are still not clear due to the lack of data support. For instance, Guo et al.
59 (2016) compared their experimental measured loads with the wave forces estimated using

60 empirical formulas. They found that the AASHTO method tends to underestimate the vertical
61 force at a smaller wave height but significantly overpredict the vertical force when the
62 specimen is fully submerged. A similar phenomenon was observed in the simulations of
63 focused wave groups conducted by Moideen and Behera (2021), that the AASHTO formulae
64 highly underestimate the peak vertical impact force for lower wave heights and moderately
65 capture the peak vertical impact force at higher wave heights. Besides, the applicability of
66 AASHTO formulas is also limited to their focused wave conditions, while accurate predictions
67 are not available for other scenarios. To overcome these shortages, a few more experimental
68 studies were then carried out in recent years (Xiang and Istrati 2021; Zhu et al. 2022; Zhu and
69 Dong 2020). Nevertheless, an accurate wave force estimation method has not been reached,
70 and more relevant studies are required to develop existing formulas. To fulfill the research gap
71 on this point, this study carries out an experimental study to investigate wave-bridge
72 interactions. Two different wave shapes, regular waves and solitary waves are tested to explore
73 the extreme waves caused by tropical cyclones and tsunamis, respectively.

74 Another significant problem associated with the study of wave-bridge interactions lies in
75 the shortage of time series analysis. Although several experimental tests and numerical
76 simulations have been conducted to measure the wave loads, most of them mainly focused on
77 the maximums of vertical and horizontal forces but neglected the changing process of pressure
78 distributions (Jin and Meng 2011; Seiffert 2014; Seiffert et al. 2016). One direct consequence
79 is that the subsequent performance assessments mostly rely on static structural analysis, which
80 typically compared the maximum load with the static bridge capacity. Such a method cannot
81 fully predict the potential risks induced by periodic wave impacts during a real storm hazard
82 and may mislead the maintenance and management strategies for high-risk bridges (Zhu et al.
83 2021). Dynamic analysis of wave-bridge interactions has aroused growing concern in recent
84 years. For example, Xu et al. (2018) performed time-domain simulations to compute the
85 combined effects of wind and waves on a three-span suspension bridge and found it challenging
86 to determine appropriate intensity measures to be considered in the structural design. Yuan et
87 al. (2021) investigated the performance of bearing connections under dynamic wave impacts

88 and found that the structural responses are highly dependent on the connection stiffness. Ding
89 et al. (2018) investigated the combined earthquake and wave-current effects on bridge piers
90 and highlighted the enlarged responses caused by the long-period hazards. All of these studies
91 pointed out the necessity of an insight understanding of the time history effects of wave impacts.
92 To address this issue, time histories of vertical and horizontal wave forces, as well as the
93 hydraulics pressures beneath the deck under various wave scenarios are measured. These
94 results not only intuitively reflect the effects of different wave parameters, but also provide
95 datasets for the training of prediction models in the following sections.

96 Experiments are reliable approaches for acquiring wave forces on coastal bridges but
97 could be extremely expensive and difficult for large-scale investigations (Xu et al. 2022).
98 Scientists and engineers tried to establish full-scale numerical models to compute
99 approximations for various hazard scenarios, while it is often prohibitive to form a sufficiently
100 large database for its unbearable computational cost, especially for the reliability and life-cycle
101 analysis involving large-scale computations (Chorzepa et al. 2016; Dong and Frangopol 2016;
102 Jia et al. 2022; Xiao and Huang 2008). To overcome this limitation, machine learning (ML)
103 methods have been utilized to establish the relationship between input hazard intensities and
104 output structural responses. For example, Xu et al. (2022) examined the prediction performance
105 of different ML technologies. It was found that ML models have superior abilities to estimate
106 the maximum wave forces, but more datasets are required to improve the model quality.
107 Besides, to facilitate the risk assessment and proposition of mitigation measures, Zhu et al.
108 (2021) utilized ML models to replace the time-consuming simulations and achieved satisfying
109 results. However, a similar problem is that existing ML technologies typically focus on the
110 peak values, but investigations on the time series effects are limited. Xu et al. (2023) performed
111 a state-of-the-art review on ML technologies in coastal bridge hydrodynamics and observed
112 that the time series predictions involving sequential data are relatively less. Also, numerical
113 simulation is still the main source of training data. To address this issue, this study develops a
114 Long Short-Term Memory (LSTM) network based on the wave force time histories measured
115 in the experiment. Different hyperparameters are tuned and validated to improve the model's

116 accuracy. The optimization model demonstrates good performance in forecasting wave forces
117 under different wave scenarios.

118 Overall, this study aims to investigate the wave impacts on coastal bridge superstructures
119 and develop data-driven ML techniques for the prediction of time series results. Time histories
120 of wave forces and pressures are investigated through laboratory experiments. LSTM models
121 are established to forecast wave impacts based on the measured wave profiles. The proposed
122 data-driven LSTMs can be an alternative to relieve the laboriousness and high cost of
123 experimental and numerical simulations on the wave-bridge interactions. The rest parts of this
124 paper are organized as follows. Section 2 introduces the laboratory testing of wave-bridge
125 interactions, including experimental design, laboratory facilities, and wave models. Section 3
126 gives an overview of the LSTM method utilized in this study. Section 4 presents the measured
127 wave forces and pressures under different wave conditions. Section 5 shows the fitting results
128 using the LSTM method and discusses the prediction performance of the promoted method.
129 Finally, conclusions, limitations, and future works are given in Section 6.

130 **2. Laboratory testing of wave-bridge interactions**

131 Laboratory tests are conducted in conjunction with activities at the Hydraulics Laboratory of
132 the Hong Kong Polytechnic University. A bridge deck mock-up is tested at the wave channel
133 to evaluate the structural performance during wave impacts. Measured datasets are mainly used
134 for two purposes: (a) quantifying adverse impacts induced by waves and comparisons with
135 existing methods and (b) providing a database for the machine learning models.

136 2.1 Investigated bridge and extreme wave model

137 The investigated bridge is one span of a simply supported bridge as shown in Fig. 1(a). This
138 type of US-90 bridge played an important role in transportation networks over Biloxi Bay,
139 Mississippi, but was severely destroyed in a category-5 storm Hurricane Katrina in 2005
140 (Robertson et al. 2007). These segments vary from 13.7 m to 15.9 m. Each segment consists of
141 six prestressed concrete girders and three pairs of diaphragms are settled between each girder.
142 However, the bearing connections between the deck and the bent are not strong enough to resist

143 extreme wave impacts. The air could be trapped between the girders and increase the uplift
 144 loads, which means these segments were nearly buoyant once submerged (Robertson et al.
 145 2006). Also, similar superstructure designs have been utilized in many other coastal highway
 146 bridges, so this type of bridge is adopted as a representative example in this study. As shown
 147 in Fig. 1(b), the selected bridge span has a length of 15.85 m and a width of 10.8 m. The girder
 148 height is 1.37m and the deck thickness is 0.18 m. The overlength out of the two sides of the
 149 deck is taken as 0.5 m.

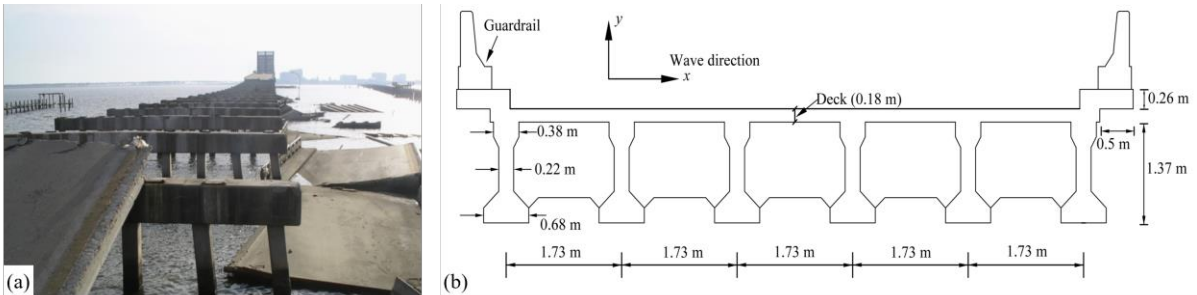

150
 151 Fig. 1 (a) Span unseating failure of US-90 Biloxi-Ocean Springs Bridges during Hurricane
 152 Katrina (Padgett et al. 2008) and (b) dimensions of the investigated bridge span

153 2.2 Experimental facilities and tested cases

154 A 1:30 scale experiment is designed according to the open channel Froude similarity law and
 155 conducted at the wave channel at the hydraulics laboratory. The Froude scale model is suitable
 156 for phenomena where gravity and inertial forces are dominant, particularly for free surface
 157 flows (e.g., coastal structures and waves). A schematic diagram of the wave channel and photos
 158 of different facilities are shown in Fig. 2(a). Surface waves are generated in the wave channel,
 159 which has a total length of 27 m, a width of 1.5 m, and a depth of 1.5 m. The span model is
 160 made of an acrylic board (as shown in Fig. 2(c)) and fixed to a platform in the middle section
 161 of the channel using steel bars. The distance from the girder bottom to the channel is 0.55 m.
 162 After being converted to the 1:30 laboratory scale, the plastic-made mock-up size is about 0.53
 163 m in length and 0.36 m in width, as shown in Fig. 2(b). Wave forces on the span are measured
 164 using a multi-axis wave load. Multiple pressure gauges are settled (as shown in Fig. 2(b)) to
 165 record the changing pressure caused by the water surface elevation and trapped air beneath the
 166 deck.

167 Two types of waves, regular waves and solitary waves are tested to account for the extreme
168 waves induced by tropical cyclones and tsunamis, respectively. The storm-induced waves are
169 highly periodic in nature, while tsunami waves are often caused by the displacement of a
170 significant volume of water under the sea. A total of 98 regular wave cases and 30 solitary wave
171 cases are tested, as listed in Table 1 and Table 2, respectively. Each case is repeatedly tested 5
172 times to avoid experimental monitoring deviations. The surface wave functions of these two
173 types of waves are given as

$$\eta_{\text{solitary}}(x, t) = H \operatorname{sech}^2 \sqrt{\frac{3}{4} \frac{H}{D^3}} (x - ct) \quad (1)$$

$$\eta_{\text{regular}}(x, t) = A \cos[k(x - ct)] \quad (2)$$

174 where η = water surface elevation; H = wave height; D = water depth; c = wave celerity; A =
175 amplitude; k = wave number; x = coordinate; and t = time. Detailed introduction of
176 experimental facilities, control strategies, and stability validations of the generated waves can
177 be found in the authors' previous work (Zhu et al. 2022; Zhu and Dong 2020).

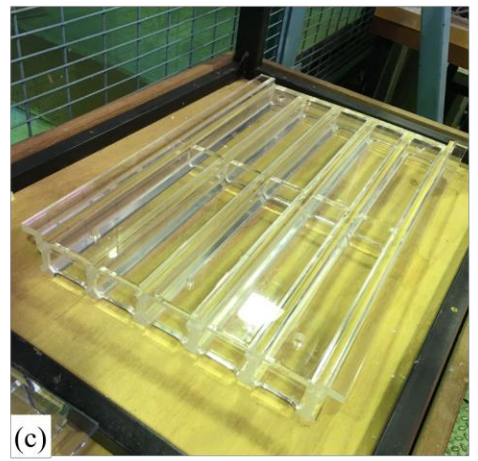
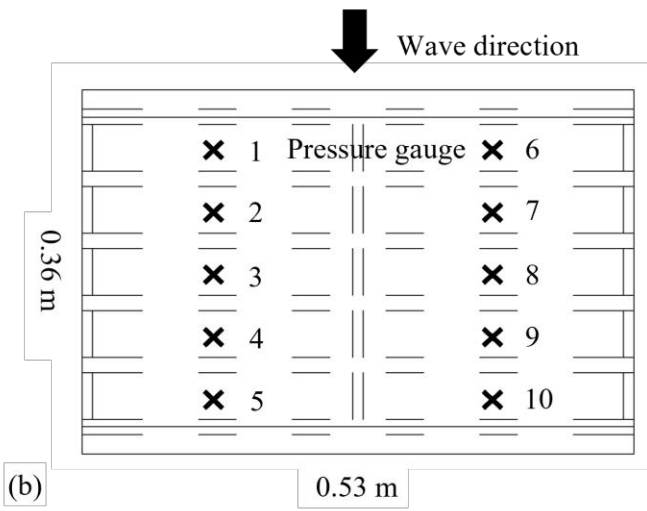
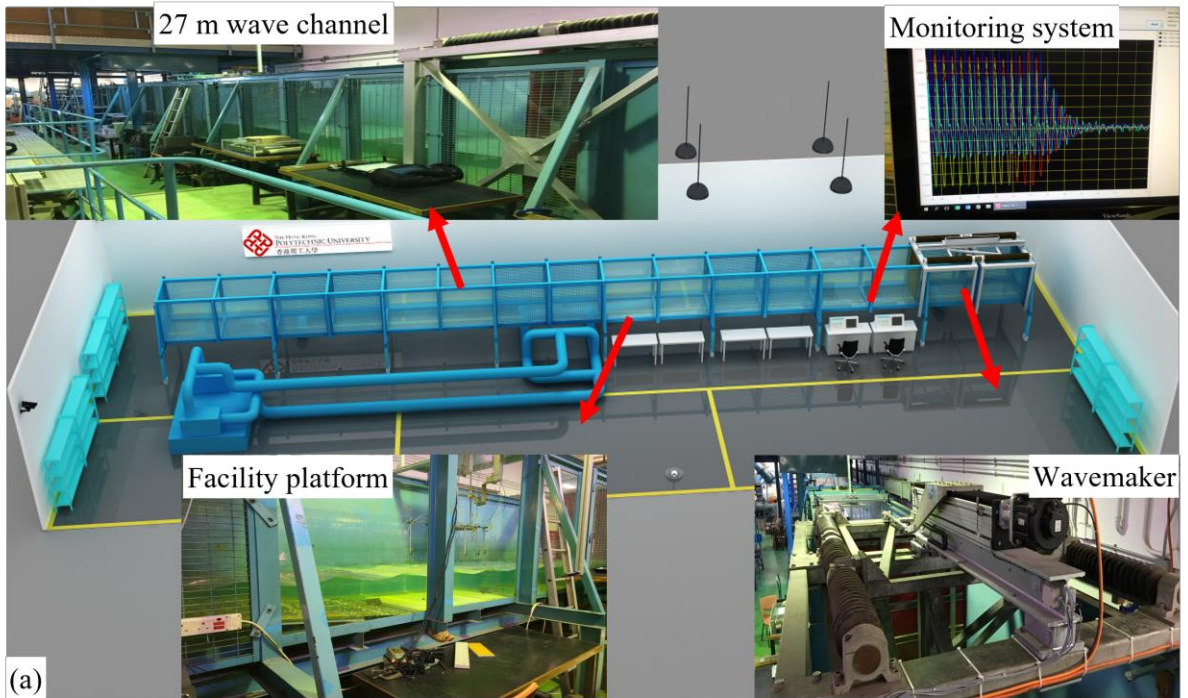

178
179
180
181
182
183

Fig. 2 (a) Schematic diagram of the hydraulics laboratory and photos of experimental facilities; (b) dimensions of the span model (top view) and distributions of the pressure gauges; and (c) photo of the acrylic board span model

Table 1 Tested regular wave cases

No.	D (m)	H (m)	T (s)	No.	D (m)	H (m)	T (s)	No.	D (m)	H (m)	T (s)
1	0.48	0.14	1	34	0.52	0.12	1.2	67	0.54	0.12	1.8
2	0.48	0.14	1.2	35	0.52	0.12	1.4	68	0.54	0.12	2
3	0.48	0.14	1.4	36	0.52	0.12	1.6	69	0.54	0.14	1
4	0.48	0.14	1.6	37	0.52	0.12	1.8	70	0.54	0.14	1.2
5	0.48	0.16	1	38	0.52	0.12	2	71	0.54	0.14	1.4

6	0.48	0.16	1.2	39	0.52	0.14	1	72	0.54	0.14	1.6
7	0.48	0.16	1.4	40	0.52	0.14	1.2	73	0.54	0.14	1.8
8	0.48	0.16	1.6	41	0.52	0.14	1.4	74	0.54	0.14	2
9	0.50	0.12	1	42	0.52	0.14	1.6	75	0.56	0.08	1
10	0.50	0.12	1.2	43	0.52	0.14	1.8	76	0.56	0.08	1.2
11	0.50	0.12	1.4	44	0.52	0.14	2	77	0.56	0.08	1.4
12	0.50	0.12	1.6	45	0.52	0.16	1	78	0.56	0.08	1.6
13	0.50	0.12	1.8	46	0.52	0.16	1.2	79	0.56	0.08	1.8
14	0.50	0.12	2	47	0.52	0.16	1.4	80	0.56	0.08	2
15	0.50	0.14	1	48	0.52	0.16	1.6	81	0.56	0.1	1
16	0.50	0.14	1.2	49	0.52	0.16	1.8	82	0.56	0.1	1.2
17	0.50	0.14	1.4	50	0.52	0.16	2	83	0.56	0.1	1.4
18	0.50	0.14	1.6	51	0.54	0.08	1	84	0.56	0.1	1.6
19	0.50	0.14	1.8	52	0.54	0.08	1.2	85	0.56	0.1	1.8
20	0.50	0.14	2	53	0.54	0.08	1.4	86	0.56	0.1	2
21	0.50	0.16	1	54	0.54	0.08	1.6	87	0.56	0.12	1
22	0.50	0.16	1.2	55	0.54	0.08	1.8	88	0.56	0.12	1.2
23	0.50	0.16	1.4	56	0.54	0.08	2	89	0.56	0.12	1.4
24	0.50	0.16	1.6	57	0.54	0.1	1	90	0.56	0.12	1.6
25	0.50	0.16	1.8	58	0.54	0.1	1.2	91	0.56	0.12	1.8
26	0.50	0.16	2	59	0.54	0.1	1.4	92	0.56	0.12	2
27	0.52	0.10	1	60	0.54	0.1	1.6	93	0.56	0.14	1
28	0.52	0.10	1.2	61	0.54	0.1	1.8	94	0.56	0.14	1.2
29	0.52	0.10	1.4	62	0.54	0.1	2	95	0.56	0.14	1.4
30	0.52	0.10	1.6	63	0.54	0.12	1	96	0.56	0.14	1.6
31	0.52	0.10	1.8	64	0.54	0.12	1.2	97	0.56	0.14	1.8
32	0.52	0.10	2	65	0.54	0.12	1.4	98	0.56	0.14	2
33	0.52	0.12	1	66	0.54	0.12	1.6				

184

185

Table 2 Tested solitary wave cases

No.	D (m)	H (m)	No.	D (m)	H (m)	No.	D (m)	H (m)	No.	D (m)	H (m)
1	0.48	0.1	9	0.5	0.14	17	0.52	0.18	25	0.56	0.1
2	0.48	0.12	10	0.5	0.16	18	0.52	0.2	26	0.56	0.12
3	0.48	0.14	11	0.5	0.18	19	0.54	0.1	27	0.56	0.14
4	0.48	0.16	12	0.5	0.2	20	0.54	0.12	28	0.56	0.16
5	0.48	0.18	13	0.52	0.1	21	0.54	0.14	29	0.56	0.18
6	0.48	0.2	14	0.52	0.12	22	0.54	0.16	30	0.56	0.2
7	0.5	0.1	15	0.52	0.14	23	0.54	0.18			
8	0.5	0.12	16	0.52	0.16	24	0.54	0.2			

186 **3. Overview of LSTM methodology**

187 For a considerable length of time, one of the primary difficulties that plagued conventional
188 neural network architectures was the incapacity to interpret input sequences that were
189 dependent on each other for relevant information (Sherstinsky 2020; Zhang et al. 2021).
190 Traditional neural networks receive an independent data vector on each occasion and lack the
191 ability to store information in memory to assist with memory-dependent tasks. To address this
192 limitation, a novel class of Recurrent Neural Networks (RNNs) was developed. This approach
193 utilizes a straightforward feedback mechanism for neurons in the network, whereby the output
194 is returned to the input to provide information about the most recent inputs. Another issue
195 associated with RNNs is the vanishing gradient problem. The vanishing gradient problem is
196 essentially a situation in which an RNN cannot propagate useful gradient information from the
197 output end of the model back to the layers near the input end of the model. It may result in
198 models with many layers being rendered unable to learn on a specific dataset. and could even
199 cause models with many layers to prematurely converge to a substandard solution (Hochreiter
200 1998).

201 To counteract the aforementioned drawback of RNN, an LSTM network is built to predict
202 wave force time series from the measured wave profiles. In accordance with the Universal
203 Approximation Theorem posited by Robert Hecht-Nielsen (Hecht-Nielsen 1992), an LSTM
204 neural network endowed with a hidden layer is capable of effectuating a mapping between
205 finite-dimensional spaces. This holds true as long as the network boasts an adequate
206 assemblage of hidden neurons, and the greater the number of said neurons, the more heightened
207 veracity of the network's approximation. Within the confines of the present paper, an LSTM
208 neural network equipped with hidden layers is appropriated as a prediction model for time
209 series wave loads. The LSTM model is built on the RNN architecture by incorporating four
210 states into a single recurrent structure. These states facilitate the persistence of a unit that
211 determines the retention of input information. Each layer of the LSTM is comprised of one
212 recurrent structure. The frequency of self-updates in the overall structure is dictated by the
213 dimensions of the input data and the number of cycles, so the current LSTM layer only requires
214 the computation of one recurrent unit, instead of multiple consecutive units.

215 The network structure of a typical LSTM cell is shown in Fig. 3, where X = input state to
 216 the cell; Y = output state of the cell; t = the number of the cell; h = hidden state output; c = cell
 217 state memory; σ = logistic sigmoid function; and \tanh = hyperbolic tangent function. The
 218 LSTM cell works as follows: the input gate controls the amount of input data from the current
 219 network that is stored in the unit at the present time; the forget gate assesses the extent of the
 220 state transition from the previous time to the present time; and the output gate governs the
 221 output of the current unit state.

222 Two performance indicators, mean squared error (MSE) and the R^2 -score, are used to
 223 evaluate the prediction performance of the established LSTM models. MSE is the metric
 224 typically used as a loss function to be minimized during network training. The main limitation
 225 of the MSE is that the assumed numerical values are not normalized with respect to the
 226 variability of the data. To overcome this point, the R^2 -score can measure the predictive power
 227 of a given model with respect to the predictive power of the trivial model, which always
 228 forecasts the mean value of the observed data (i.e., $R^2 = 0$). The R^2 -score is widely used because
 229 it can be seen as a normalized version of the R^2 . These two indicators are calculated as

$$MSE(y, \hat{y}) = \frac{1}{N} \sum (y - \hat{y})^2 \quad (3)$$

$$R^2(y, \hat{y}) = 1 - \frac{MSE(y, \hat{y})}{MSE(y, \bar{y})} = 1 - \frac{\sum (y - \hat{y})^2}{\sum (y - \bar{y})^2} \quad (4)$$

230 where y = the measured data in the experiment; y' = the predicted value using LSTMs; and \bar{y}
 231 = mean of the truth data.

232

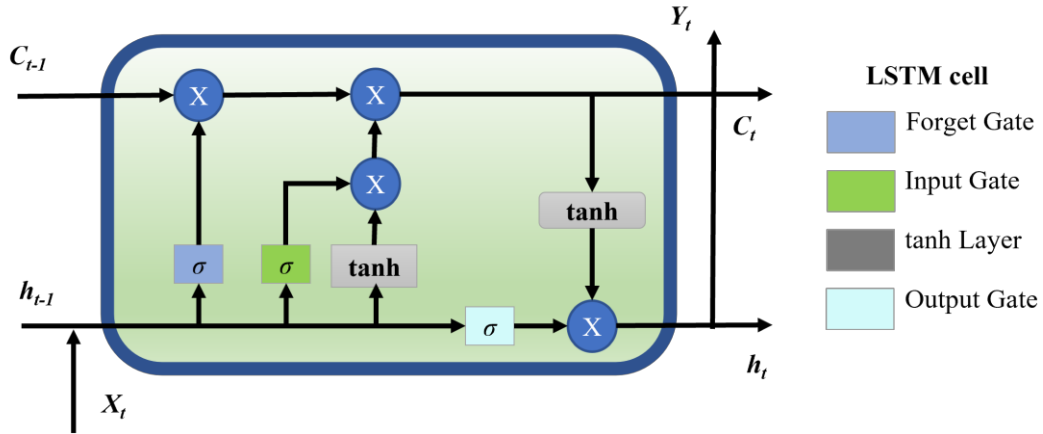

233

234

Fig. 3 Network structure of a typical LSTM cell

235 **4. Wave-induced forces and comparisons with previous studies**

236 The wave loads on the bridge span are dependent on both structural dimensions and wave
 237 parameters, so impacts caused by regular waves and solitary waves are investigated separately.
 238 To obtain more insight into wave force characteristics, vertical and horizontal wave forces as
 239 well as the hydraulics pressure on the specimen are analyzed.

240 **4.1 Solitary wave results**

241 By collecting the measured results from the load cell and pressure gauges, Fig. 4 shows three
 242 typical time series results of vertical forces and pressures applied on the specimen under
 243 solitary wave cases with $D = 0.48$ m and $H = 0.18$ m, $D = 0.52$ m and $H = 0.18$ m, and $D =$
 244 0.56 m and $H = 0.18$ m. Because of the symmetric distributions of the pressure gauges, only
 245 the measured data from gauges 1-5 are presented. As shown in Fig. 4, both the wave forces and
 246 pressures increase to a maximum value and then drop to a valley as the propagation of solitary
 247 waves. For a constant wave height $H = 0.18$ m, the maximum values of vertical forces F_y
 248 increase from 74.15 to 113.64 N as water depth increases. However, there are little changes in
 249 the maximums of horizontal forces F_x , which are around 47.90 N, 40.17 N, and 43.80 N
 250 respectively. For the wave pressures, pressures measured at the seaward side facing the waves,
 251 i.e., wave gauge 1, are around 20-30% larger than those measured at the opposite side. This
 252 means that not only the concrete components in these areas are subject to greater impacts, but
 253 also the connections may suffer from higher loads. In addition, the pressures decrease to a

254 negative value after the wave crest passes the span, and the downward forces are caused by the
255 vacuum area created beneath the span when the water surface drops rapidly. The minimum
256 negative pressures reduce for larger water depths and are around -266.74 Pa, -334.49 Pa, and -
257 342.26 Pa, respectively. Most of the previous studies only focuses on the maximum vertical
258 and horizontal forces induced by extreme waves, but recent ones have pointed out the
259 concentrated wave pressure and the subsequent overturning moment could also be critical
260 reasons for span failure (Cai et al. 2018; Istrati and Buckle 2019; Zhu et al. 2021). Therefore,
261 both the maximum wave forces and pressures are analyzed in the following sections.

262 By tracing the time histories of the monitored data, the maximum values of vertical force,
263 horizontal force, and pressure are collected and presented in Fig. 5. The final results are taken
264 by removing the maximum and minimum values from all five trials for each wave case, and
265 then averaging the rest results. The projections of the maximums on the xz -plane are plotted as
266 well. It should be noted that all of the pressure results are taken from pressure gauge 1 since it
267 records the highest pressure for all the cases. From the test results, the following can be
268 observed: (a) The maximums of F_y , and P show a close-linear relationship with both wave
269 height H and water depth D . However, F_x only increases for larger H , but changes little with D .
270 (b) The maximum pressure for the tested cases is 1362.58 Pa, which equals 40.88 kPa after
271 being converted to a prototype scale. The concentrated pressure at the seaward side is around
272 20-30% over the average value. (c) Solitary wave-induced impacts are mainly affected by the
273 wave height H and the water depth (or clearance between the water level and the bridge span).
274 This phenomenon is consistent with its characteristics, that the solitary waves are non-periodic
275 fluctuations with their volume and energy highly concentrated.

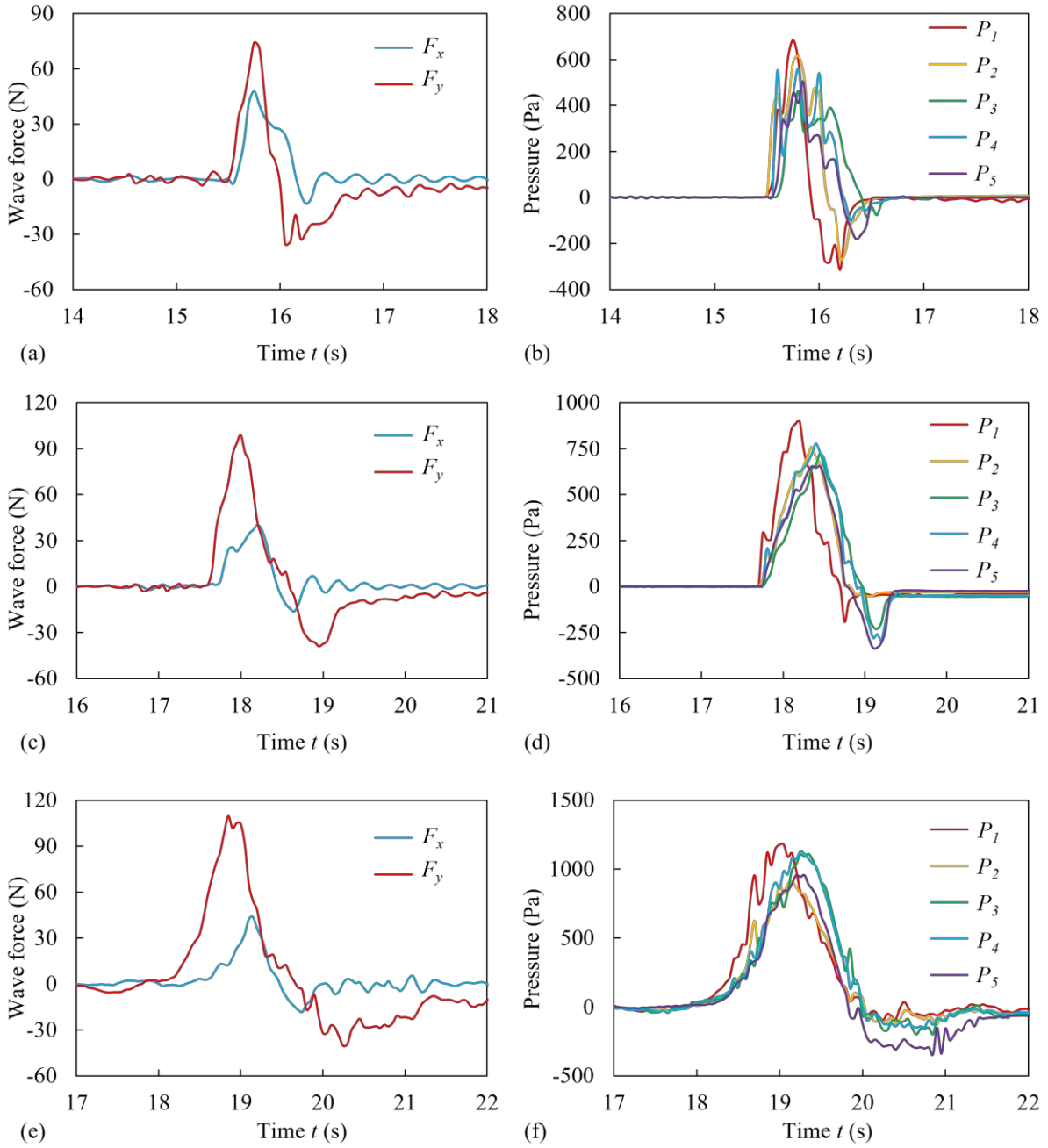

276

277

278

279

280

281

Fig. 4 Time histories of (a) wave force for case $D = 0.48$ m and $H = 0.18$ m; (b) surface pressure for case $D = 0.48$ m and $H = 0.18$ m; (c) wave force for case $D = 0.52$ m and $H = 0.18$ m; (d) surface pressure for case $D = 0.52$ m and $H = 0.18$ m; (e) wave force for case $D = 0.56$ m and $H = 0.18$ m; and (f) surface pressure for case $D = 0.56$ m and $H = 0.18$ m

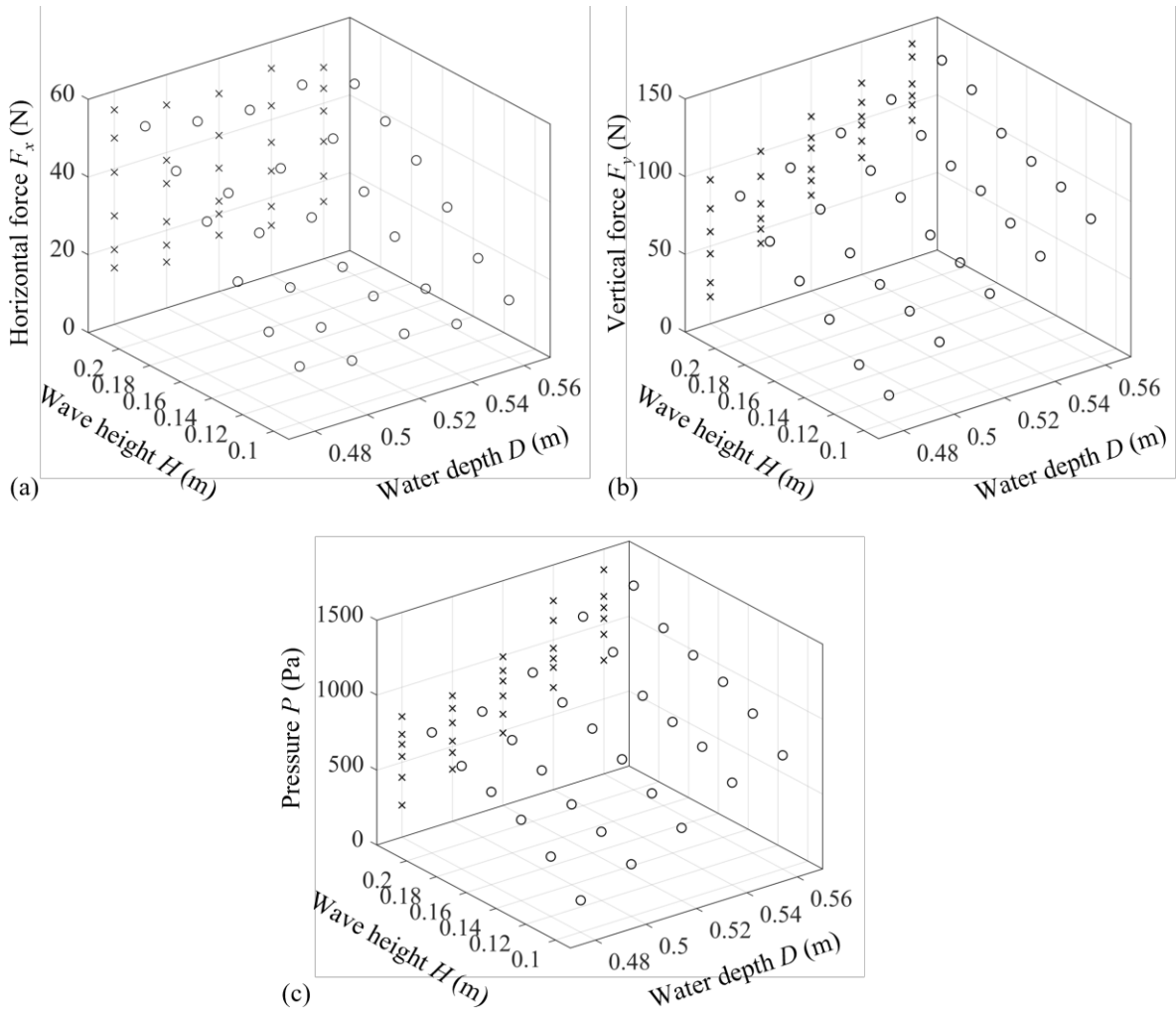

282

283 Fig. 5 Maximums of solitary wave impacts: (a) maximum horizontal force; (b) maximum

284 vertical force; and (c) maximum pressure

285 4.2 Regular wave results

286 Time series results of representative cases are plotted in Figs 6 and 7. Different from solitary

287 waves, although the load and pressure also experience periodic positive and negative changes

288 as the water surface rises and falls, they are dependent on the wave period T as well. Fig. 6

289 compares the effects of different periods ($T = 1.2$ s, 1.4 s, and 2.0 s) under a constant water

290 depth ($D = 0.52$ m) and wave height ($H = 0.14$ m). The peak values of F_y decrease from 71.70

291 to 27.97 N as wave period T increases. For the horizontal force F_x and pressure P , the

292 maximums also decrease from 43.31 to 12.86 N and from 1808.20 to 466.53 Pa, respectively.

293 As shown in Fig. 7 for the cases with $D = 0.56$ m and $H = 0.14$ m, another difference between

294 solitary and regular waves lies in the maximum pressure. Pressure gauge 1 always measures

295 the largest P among all the solitary wave conditions, while it may occur at different positions
296 under regular wave conditions, e.g., $P_5 = 1858.12$ Pa and $P_3 = 760.32$ Pa.

297 Maximum horizontal force, vertical force, and pressure under different wave conditions
298 are plotted in Figs. 8-10. As indicated, F_x , F_y , and P all increase for larger wave height H .
299 However, the maximum values are observed when water depth $D = 0.52$ and 0.54 m (i.e.,
300 clearances between the girder bottom and initial water surface equal 0.03 and 0.01 m), which
301 is $F_x = 54.35$ N, $F_y = 93.83$ N, and $P = 2304.54$ Pa, respectively. For the effects of wave period
302 T , the wave impacts show a trend of first increasing and then decreasing as the T grows. The
303 peak values are always observed when T is around $1.2 - 1.4$ s, i.e., corresponding wavelength
304 λ ranges from $2.03 - 2.66$ m, frequency ν ranges from $4.49 - 6.28$ Hz, and the non-dimensional
305 parameter deck-wavelength ratio from $0.14 - 0.24$. This phenomenon indicates that, in the
306 design stage of coastal bridges, the structural dimensions of the span can be adjusted to mitigate
307 the wave impacts.

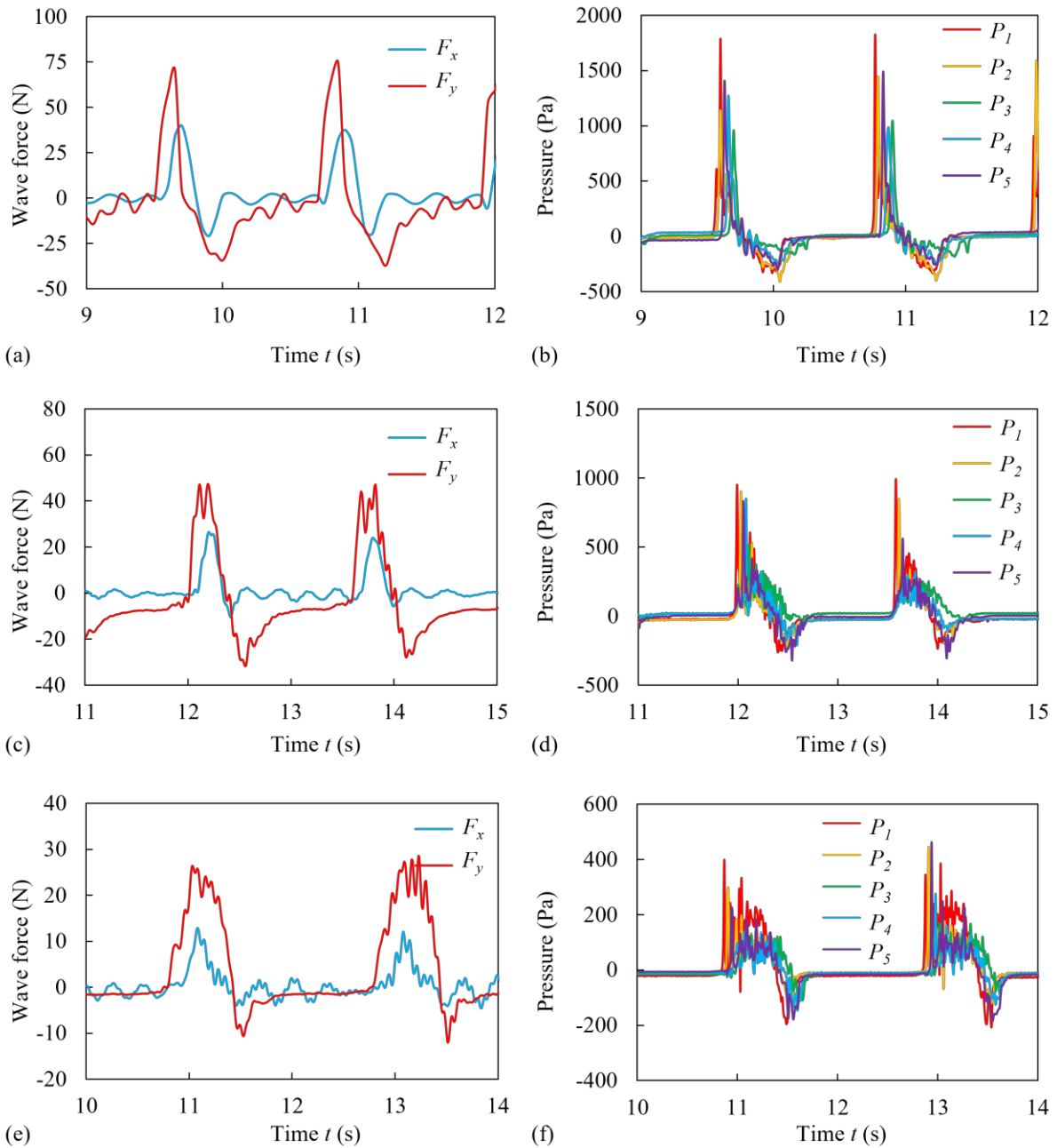

308

309

310

311

312

313

314

Fig. 6 Time histories of (a) wave force for case $D = 0.52$ m, $H = 0.14$ m, and $T = 1.2$ s; (b) surface pressure for case $D = 0.52$ m, $H = 0.14$ m, and $T = 1.2$ s; (c) wave force for case $D = 0.52$ m, $H = 0.14$ m, and $T = 1.6$ s; (d) surface pressure for case $D = 0.52$ m, $H = 0.14$ m, and $T = 1.6$ s; (e) wave force for case $D = 0.52$ m, $H = 0.14$ m, and $T = 2.0$ s; and (f) surface pressure for case $D = 0.52$ m, $H = 0.14$ m, and $T = 2.0$ s

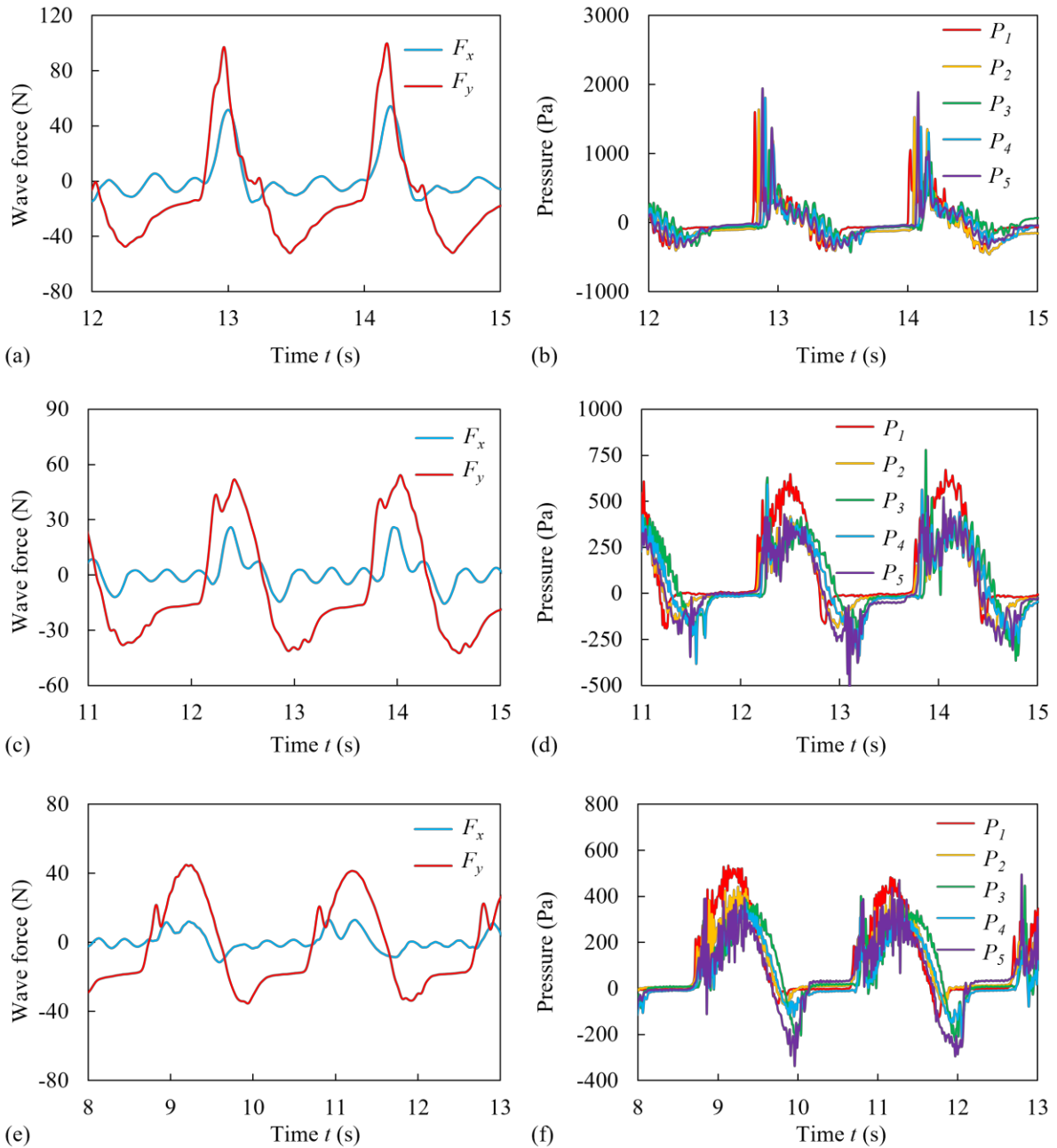

315
 316 Fig. 7 Time histories of (a) wave force for case $D = 0.56$ m, $H = 0.14$ m, and $T = 1.2$ s; (b)
 317 surface pressure for case $D = 0.56$ m, $H = 0.14$ m, and $T = 1.2$ s; (c) wave force for case $D =$
 318 0.56 m, $H = 0.14$ m, and $T = 1.6$ s; (d) surface pressure for case $D = 0.56$ m, $H = 0.14$ m, and
 319 $T = 1.6$ s; (e) wave force for case $D = 0.56$ m, $H = 0.14$ m, and $T = 2.0$ s; and (f) surface
 320 pressure for case $D = 0.56$ m, $H = 0.14$ m, and $T = 2.0$ s
 321

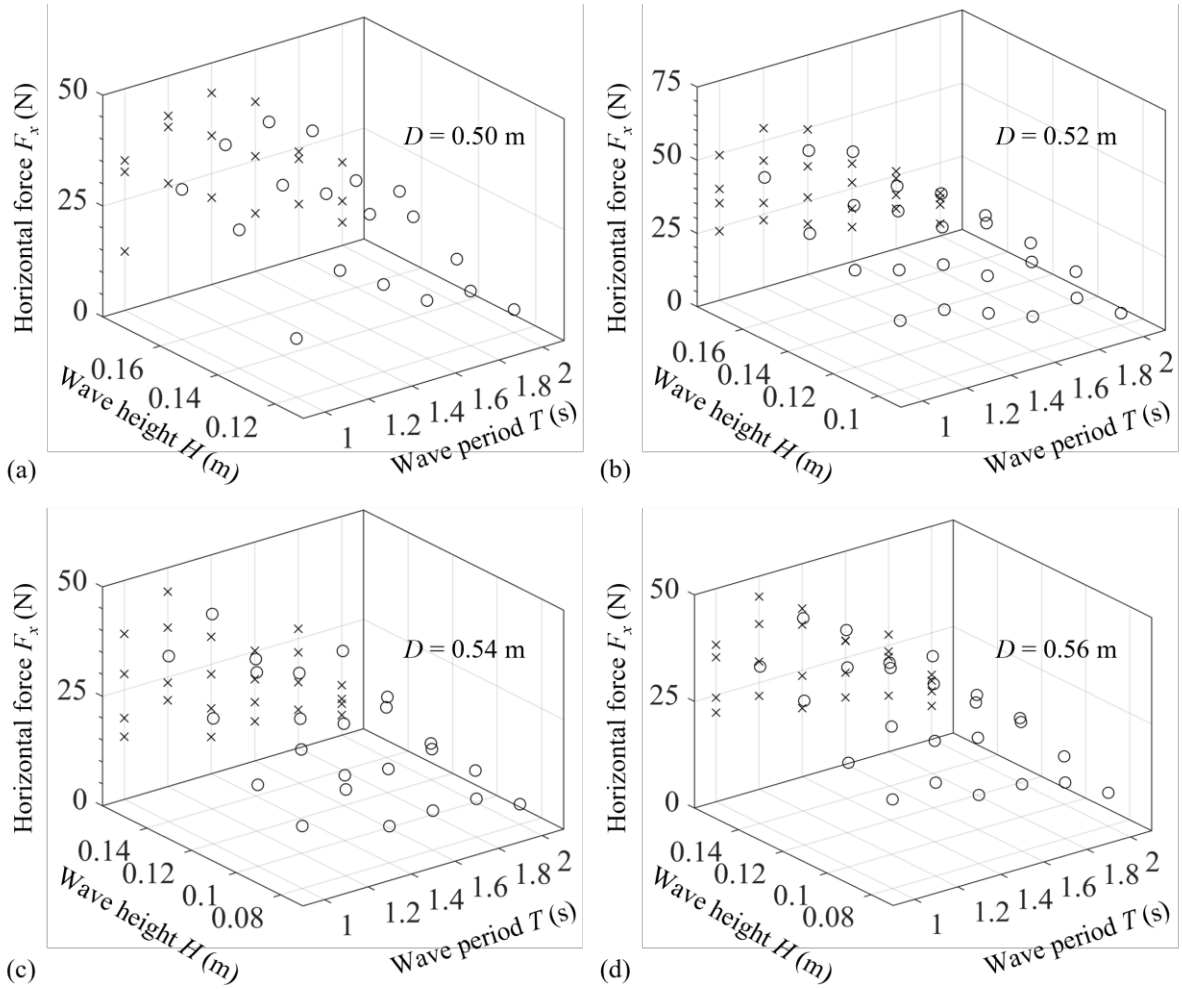

322

323 Fig. 8 Maximum horizontal forces under regular wave impacts for cases with (a) $D = 0.50$ m;

324

(b) $D = 0.52$ m; (c) $D = 0.54$ m; and (d) $D = 0.56$ m

325

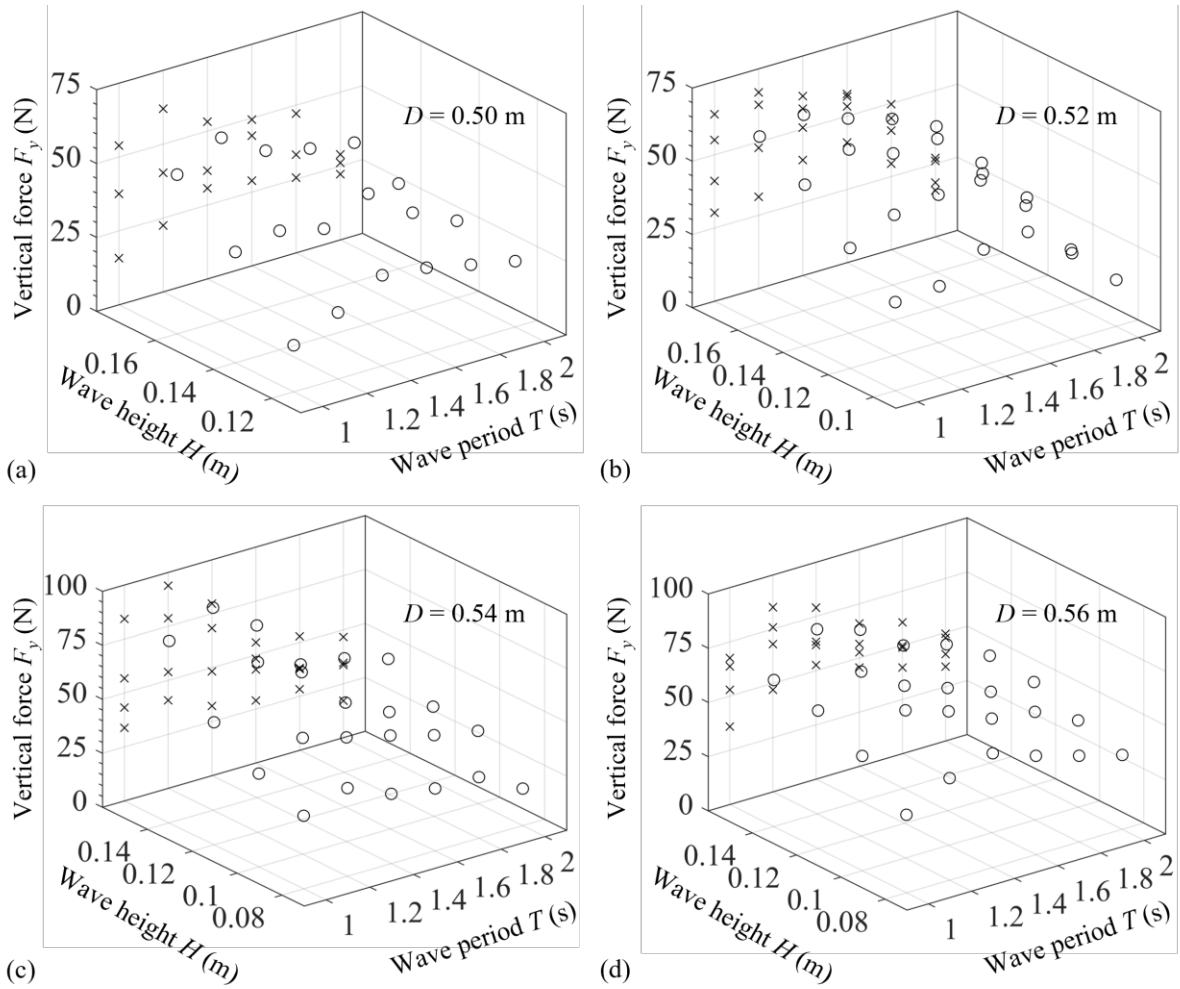

326

327 Fig. 9 Maximum vertical forces under regular wave impacts for cases with (a) $D = 0.50$ m;

328

(b) $D = 0.52$ m; (c) $D = 0.54$ m; and (d) $D = 0.56$ m

329

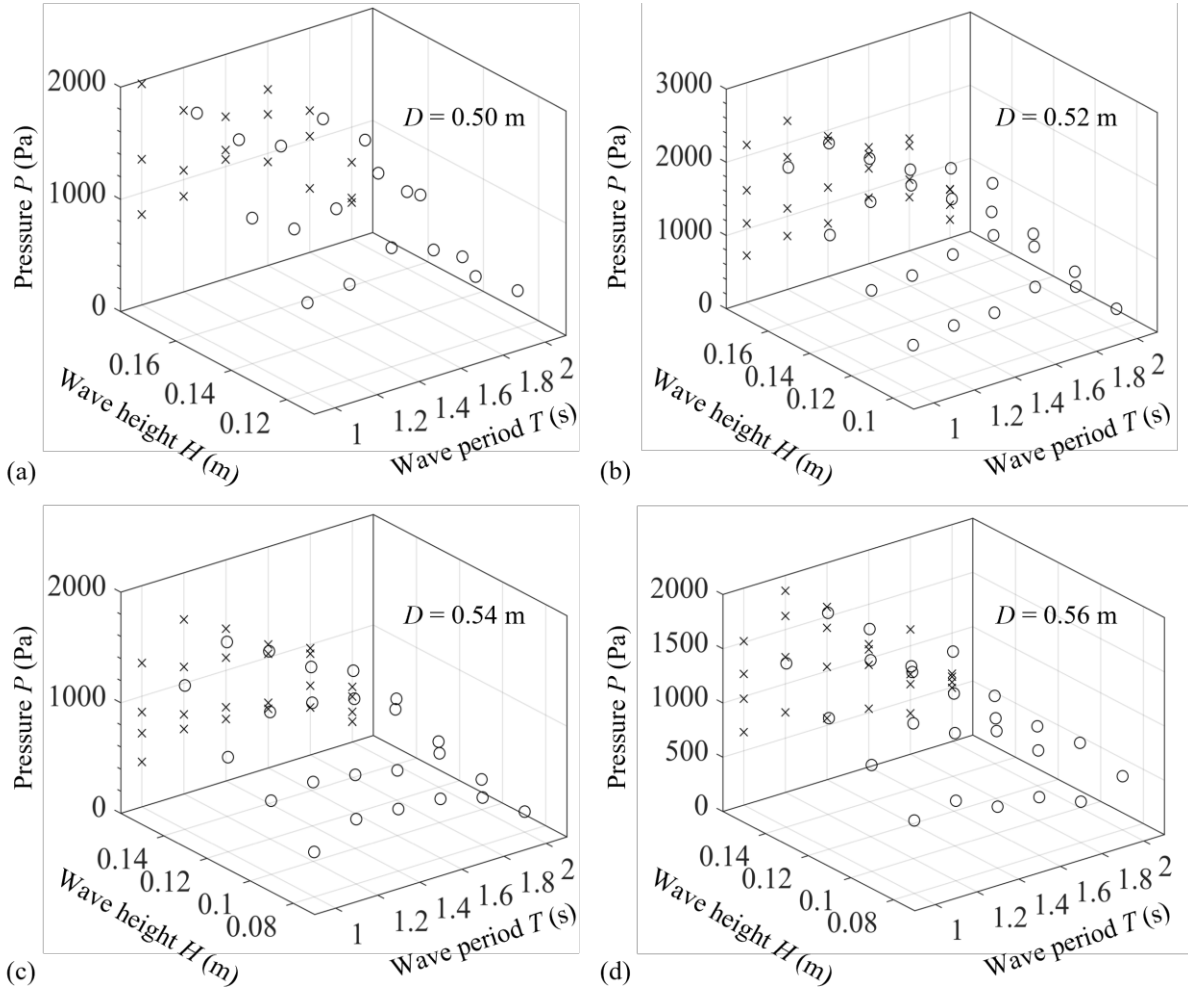

330

331 Fig. 10 Maximum pressures under regular wave impacts for cases with (a) $D = 0.50$ m; (b) D

332

= 0.52 m; (c) $D = 0.54$ m; and (d) $D = 0.56$ m

333 5. ML results

334 To explore the relationships between wave-induced forces and excitation waves, and to provide

335 a highly efficient tool for stochastic analysis in future studies, this section develops advanced

336 LSTM models for predicting time series wave impacts. The training process, model

337 performance, and tuning of different hyperparameters are presented in this section.

338 5.1 Development of LSTM models

339 Advanced deep learning models, which are based on a multi-layer architecture centered on

340 LSTM cells, have been constructed for solitary wave and regular wave impacts, respectively.

341 A total of 294 datasets of the experimental measurements (98 cases, 3 repeated tests for each

342 case) are utilized for the LSTM training of regular waves, and 90 datasets (30 cases, 3 repeated
343 tests for each case) are used for solitary waves. The changing wave profiles collected from the
344 wave gauges are used as the model input, and the wave force time series are used as the output.
345 During the model training, 70% of the raw data are used as the training set, 15% are used as
346 the test set, and the rest 15% are used as the validations set. A potential benefit of this approach
347 is that the LSTM prediction results can reduce the deviations caused by the repeated tests, since
348 it comprehensively incorporates all the datasets.

349 To scale up the number of hidden layer neural networks, the accuracy of the operation
350 must first be scrutinized, followed by an analysis of the time demands inherent in sample
351 training and prediction. In an event that the number of neurons contained within the hidden
352 layer is insufficient, the learning accuracy will be reduced and the number of required training
353 iterations will rise commensurately. Conversely, if the number of neurons surpasses a certain
354 threshold, the network's complexity shall escalate, thereby inflating the requisite training time
355 and the number of mandatory weights. It follows that the ultimate output of the neural network
356 hinges on the number of hidden neurons employed. Therefore, in this investigation, a total of
357 128 hidden neurons are selected after several trials.

358 Since each node residing within the fully connected layer is connected to all antecedent
359 nodes, its role is to meld the salient characteristics previously distilled from the earlier layer,
360 and then assimilate the hidden patterns intrinsic to the time series at hand. Considering both
361 the computational efficiency and model accuracy, it is found that 64 nodes have been deemed
362 adequate for deployment in the fully connected layer in this context.

363 Regarded as a critical hyperparameter in both supervised and deep learning, the learning
364 rate governs the capacity of the objective function to converge upon a local minimum within a
365 given timeframe. An optimal learning rate facilitates the objective function's resolution within
366 a reasonable duration of time. In the context of this study, the optimal learning rate has been
367 determined via rigorous experimentation to be 0.005.

368 The network training is conducted employing TensorFlow, a well-established and
369 documented open-source symbolic math library developed by the Google Brain team for

370 machine learning applications. This library boasts a flexible data flow architecture, enabling
371 high-performance training of various types of neural networks on multiple platforms, including
372 CPUs, GPUs, and TPUs. The simulations discussed in this paper are carried out on a desktop
373 computer equipped with 12th Intel Core i7-12700K CPUs and an NVIDIA GTX 1080Ti GPU
374 card.

375 Notably, although a similar structure is used for the two sets of LSTM models for solitary
376 wave and regular wave, their hyperparameters, such as weights and biases, are different due to
377 the differences in their respective input data. Fig. 11 distinctly displays the loss curves of these
378 prediction models during the training process. Fig. 12 presents comparative results of the
379 LSTM prediction wave loads with the experimental measurements. The small loss value after
380 600 iterations and the good convergence observed from the comparisons prove the good
381 prediction performance of the developed LSTM models.

382 These experimental-data-based LSTM models have the following advantages as
383 compared with conventional wave loads estimation methods: (a) Fewer deviations because of
384 the raw experimental data used as the training set. Previous ML models usually utilized a few
385 wave parameters (e.g., wave height H and wavelength λ) as the input of the model, while the
386 influence of the changing wave profiles was ignored (Chen et al. 2021; Wang et al. 2021). Also,
387 the deviations in the repetitive tests were often expressed using the mean value and standard
388 deviation, but without being considered in the prediction models. The developed LSTM models
389 overcome this limitation by incorporating the time series datasets obtained from the repeated
390 experiments into the model training. (b) Higher efficiency as compared with numerical
391 simulations. A refined hydrodynamics model usually takes hours or even days to reproduce the
392 wave-bridge interactions and compute the wave loads, which is unacceptable for stochastic
393 analysis involving a large number of calculations. A well-trained LSTM model could predict
394 load characteristics from measured waveforms in seconds. (c) Easier expansions due to its
395 network structures. The design guide specification (AASHTO 2008) also pointed out that one
396 important reason limiting the development of wave load prediction methods is that the
397 measured results are often more applicable to the investigated conditions, while additional

398 experiments are required for other scenarios. The developed LSTM models could facilitate this
 399 approach to a certain extent through transfer learning methods (Weiss et al. 2016), which
 400 effectively preserve hidden layers in the network structure, and augment additional layers based
 401 on a smaller amount of data.

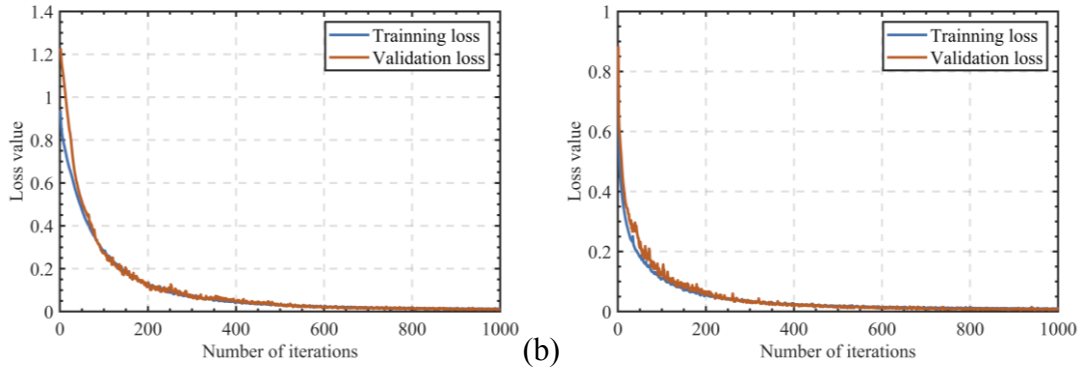

402 (a) (b)
 403 Fig. 11 Loss curves of trained LSTM models in different datasets (a) solitary waves; (b)
 404 regular waves

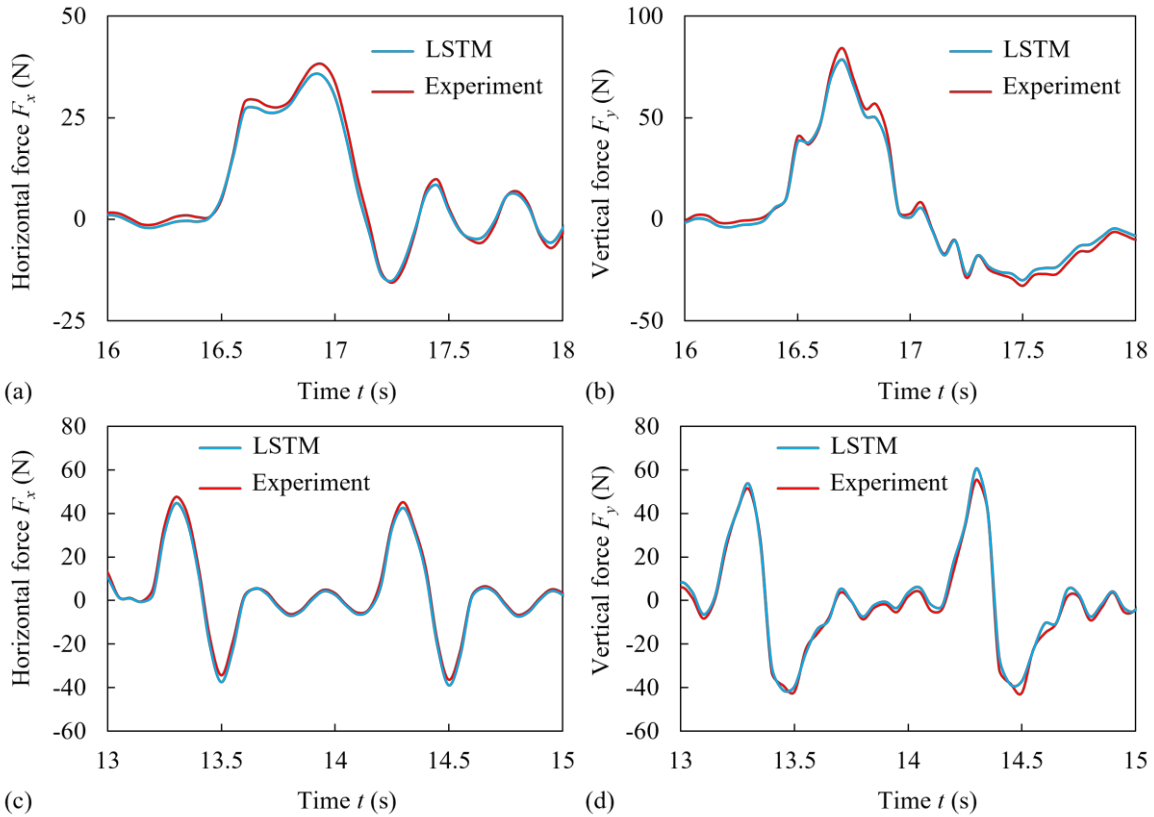

406 (c) (d)
 407 Fig. 12 Comparisons between LSTM predicted results and experimental measurements: (a)
 408 F_x of solitary wave case with $D = 0.5$ m and $H = 0.16$ m; (b) F_y of solitary wave case with D

409 = 0.5 m and $H = 0.16$ m; (c) F_y of regular wave case with $D = 0.5$ m, $H = 0.14$ m, and $T = 1$ s;
410 and (d) F_y of regular wave case with $D = 0.5$ m, $H = 0.16$ m, and $T = 1$ s

411 5.2 Hyperparameter tuning

412 To have a deeper understanding of the developed models, the impacts of hyperparameter
413 configurations on the performance of an LSTM model are explored in this section. Specifically,
414 the effect of learning rate and dropout settings on the model prediction results are discussed.
415 The importance of hyperparameter tuning in optimizing machine learning models is well-
416 recognized. Therefore, comprehending the effect of individual hyperparameters on the model's
417 performance is crucial for customizing the model for a given task. Precisely, determining an
418 appropriate learning rate and dropout rate can significantly enhance the model's predictive
419 capacity. The tested learning rates range from 10^{-4} to 10^{-2} , while the dropout values span from
420 0.2 to 0.7. To assess the influence of hyperparameters on the model prediction results, two
421 performance indicators, mean squared error (MSE) and coefficient of determination (R^2),
422 which were introduced in Section 2, are utilized. These metrics offer a reliable approach for
423 evaluating the model's predictive capability relative to the actual observations.

424 For the solitary wave load LSTM prediction model, Figs. 13 (a) and (b) show the model's
425 predictive performance variation with respect to different learning rates for the same dropout
426 values. Our analysis reveals a quadratic relationship between the model's predictive ability and
427 the learning rate, leading to a single-peak curve in the model performance graph. The optimal
428 learning rate is approximately 0.001. These findings highlight the importance of choosing an
429 appropriate learning rate to optimize the model's prediction capability. On the other hand, Figs.
430 13 (c) and (d) illustrate the change in predictive performance with different dropout values for
431 the same learning rate. Interestingly, no clear trend is observed in the model performance curve,
432 indicating that the impact of dropout on the model's performance is relatively minor. However,
433 it is worth noting that a dropout value of 0.5 typically results in the worst predictive
434 performance, and its use should be avoided in practical applications. Moreover, these analyses
435 reveal that when the learning rate is low (approximately 0.001 to 0.003), the effect of dropout
436 on the model's predictive accuracy is minimal. This finding is significant as it suggests that in

437 certain scenarios, the dropout value may not be critical to the model's overall performance
 438 when the learning rate is sufficiently low.
 439

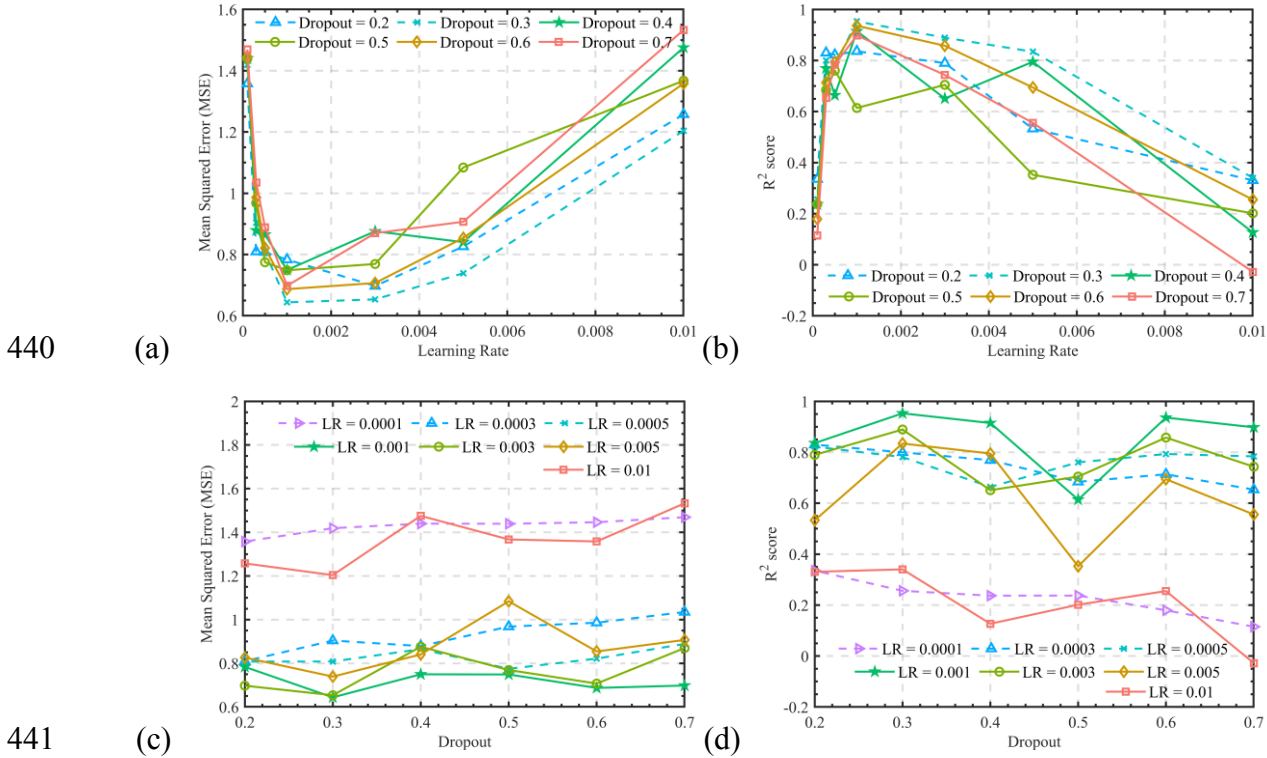

442 Fig. 13 Hyperparameter tuning results for LSTM prediction model of solitary waves: (a), (b)
 443 MSE and R^2 with respect to different learning rates for the same dropout values; and (c), (d)
 444 MSE and R^2 with respect to different dropout values for the same learning rate

446 Tuning results for the LSTM models of regular waves are shown in Fig. 14. Similar to the
 447 solitary wave LSTM model, the regular wave model also exhibits an optimal prediction
 448 performance when the learning rate is set to 0.001, and the changes in the predictive efficacy
 449 with respect to the variation of dropout values are not significant. It is worth noting that both
 450 models demonstrate the same optimal hyperparameter configuration, where the learning rate is
 451 set to 0.001, and the dropout rate is set to 0.3. This observation highlights the importance of
 452 fine-tuning hyperparameters for machine learning models, as finding the optimal combination
 453 of hyperparameters can significantly improve the model's performance. Furthermore, the
 454 consistent hyperparameter configuration for the two models suggests that these settings could

455 be a good starting point for developing similar models in the future, particularly for predicting
 456 loads induced by ocean waves.

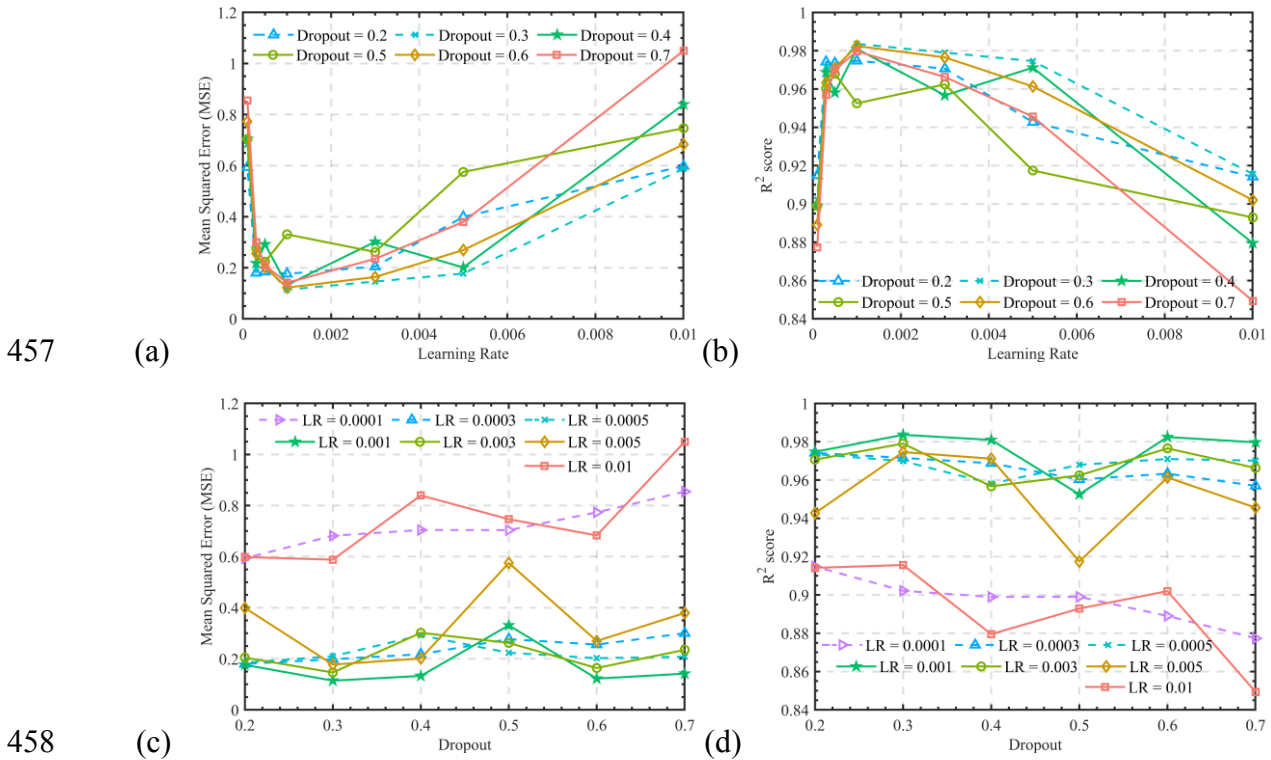

459 Fig. 14 Hyperparameter tuning results for LSTM prediction model of regular waves: (a), (b)
 460 MSE and R^2 with respect to different learning rates for the same dropout values; and (c), (d)
 461 MSE and R^2 with respect to different dropout values for the same learning rate

462 6. Conclusions

463 This paper presents a hydrodynamic experiment on wave-bridge interactions and the
 464 development of data-driven LSTM techniques for time series forecasting of wave forces.
 465 Specifically, a 1:30 scale bridge superstructure specimen is used for the wave test in the wave
 466 channel under different solitary wave and regular wave conditions. Time histories of wave
 467 profiles, wave-induced forces, and pressures are measured and served as a dataset basis for the
 468 training of LSTM models. High-performance LSTM prediction models are developed through
 469 the tuning of different hyperparameters. From the measurements of the experimental data and
 470 the establishment of LSTM models, the following conclusions can be made:

- 471 1. Through experimental measurements of wave-induced pressure on the bridge span, it
 472 is observed that there is a concentrated uplift pressure on the seaward side (facing the

473 waves) of the deck under all the solitary wave conditions and most regular wave
474 conditions. The maximum value of the pressure P at the seaward side could be 20 –
475 30% larger than the opposite side and could reach 2304.54 Pa. This phenomenon may
476 induce a large overturning moment on the deck, affecting structural stability.

477 2. After comparing the measured wave forces under different wave conditions, it is
478 found that under similar wave amplitudes and clearances, solitary waves and regular
479 waves may cause close vertical forces on the deck, while the horizontal forces caused
480 by regular waves are much larger. This means the different wave profiles may also
481 affect the wave forces and should be accounted for in the prediction methods.

482 3. LSTM models with 128 hidden neurons, 64 nodes in each connected layer, and a
483 learning rate of 0.001 are developed to have the optimal forecasting performance for
484 wave-induced forces. Through the investigations on different hyperparameters, it is
485 found that when the learning rate is low (from 0.001 to 0.003), the effect of dropout
486 on the model's predictive accuracy is relatively small.

487 4. The experimental-data-based LSTM prediction models have the advantages of less
488 deviation and higher efficiency. LSTM models for both wave types have satisfying
489 R^2 -source values close to 0.98, and small MSEs at a 10^{-1} level. The well-trained model
490 could predict the wave force time series based on the excitation wave profiles in
491 seconds.

492 **Acknowledgments**

493 The study has been supported by the Research Grants Council of Hong Kong (PolyU 15225722
494 and PolyU 15221521) and department of Civil and Environmental Engineering of the Hong
495 Kong Polytechnic University (1-WZ0B). The support is gratefully acknowledged. The
496 opinions and conclusions presented in this paper are those of the authors and do not necessarily
497 reflect the views of the sponsoring organizations.

498 **References**

499 AASHTO. (2008). *Guide specifications for bridges vulnerable to coastal storms*. American

500 Association of State Highway and Transportation Officials, Washington, US.

501 Ataei, N., and Padgett, J. E. (2013). Probabilistic modeling of bridge deck unseating during
502 hurricane events. *Journal of Bridge Engineering*, 18(4), 275–286.

503 Azadbakht, M., and Yim, S. C. (2016). Effect of trapped air on wave forces on coastal bridge
504 superstructures. *Journal of Ocean Engineering and Marine Energy*, 2(2), 139–158.

505 Bradner, C., Schumacher, T., Cox, D., and Higgins, C. (2011). Experimental setup for a large-
506 scale bridge superstructure model subjected to waves. *Journal of Waterway, Port, Coastal
507 and Ocean Engineering*, 137(1), 3–11.

508 Cai, Y., Agrawal, A., Qu, K., and Tang, H. S. (2018). Numerical Investigation of Connection
509 Forces of a Coastal Bridge Deck Impacted by Solitary Waves. *Journal of Bridge
510 Engineering*, 23(1), 04017108.

511 Chen, X., Chen, Z., Xu, G., Zhuo, X., and Deng, Q. (2021). Review of wave forces on bridge
512 decks with experimental and numerical methods. *Advances in Bridge Engineering*, 2(1),
513 1–24.

514 Chorzepa, M. G., Saeidpour, A., Christian, J. K., and Durham, S. A. (2016). Hurricane
515 vulnerability of coastal bridges using multiple environmental parameters. *International
516 Journal of Safety and Security Engineering*, 6(1), 10–18.

517 Cuomo, G., Shimosako, K. ichiro, and Takahashi, S. (2009). Wave-in-deck loads on coastal
518 bridges and the role of air. *Coastal Engineering*, 56(8), 793–809.

519 Ding, Y., Ma, R., Shi, Y. D., and Li, Z. X. (2018). Underwater shaking table tests on bridge
520 pier under combined earthquake and wave-current action. *Marine Structures*, 58, 301–
521 320.

522 Dong, Y., and Frangopol, D. M. (2016). Probabilistic Time-Dependent Multihazard Life-Cycle
523 Assessment and Resilience of Bridges Considering Climate Change. *Journal of
524 Performance of Constructed Facilities*, 30(5).

525 Guo, A., Liu, J., Chen, W., Bai, X., Liu, G., Liu, T., Chen, S., and Li, H. (2016). Experimental
526 study on the dynamic responses of a freestanding bridge tower subjected to coupled
527 actions of wind and wave loads. *Journal of Wind Engineering and Industrial*

528 *Aerodynamics*, 159(10), 36–47.

529 Hecht-Nielsen, R. (1992). Theory of the backpropagation neural network. *Neural networks for*
530 *perception*, 65–93.

531 Hochreiter, S. (1998). The vanishing gradient problem during learning recurrent neural nets
532 and problem solutions. *International Journal of Uncertainty, Fuzziness and Knowledge-*
533 *Based Systems*, 6(2), 107–116.

534 Istrati, D., and Buckle, I. (2019). Role of trapped air on the tsunami-induced transient loads
535 and response of coastal bridges. *Geosciences (Switzerland)*, 9(4).

536 Jia, L., Zhang, Y., Zhu, D., and Dong, Y. (2022). 3D Numerical Modeling and Quantification
537 of Oblique Wave Forces on Coastal Bridge Superstructures. *Journal of Marine Science*
538 *and Engineering*, 10(7), 860.

539 Jin, J., and Meng, B. (2011). Computation of wave loads on the superstructures of coastal
540 highway bridges. *Ocean Engineering*, 38(17–18), 2185–2200.

541 Meng, B., and Jin, J. (2007). Uplift wave load on the superstructure of coastal bridges. *New*
542 *Horizons and Better Practices*, 1-10.

543 Moideen, R., and Behera, M. R. (2021). Numerical investigation of extreme wave impact on
544 coastal bridge deck using focused waves. *Ocean Engineering*, 234, 109227.

545 Padgett, J., Desroches, R., Nielson, B., Yashinsky, M., Kwon, O. S., Burdette, N., and Tavera,
546 E. (2008). Bridge damage and repair costs from Hurricane Katrina. *Journal of Bridge*
547 *Engineering*, 13(1), 6–14.

548 Qu, K., Tang, H. S., Agrawal, A., Cai, Y., and Jiang, C. B. (2018). Numerical investigation of
549 hydrodynamic load on bridge deck under joint action of solitary wave and current. *Applied*
550 *Ocean Research*, 75, 100–116.

551 Robertson, I. N., Riggs, R. H., Yim, S. C. S., and Young, Y. L. (2007). Lessons from Hurricane
552 Katrina storm surge on bridges and buildings. *Journal of Waterway, Port, Coastal and*
553 *Ocean Engineering*, 133(6), 463–483.

554 Robertson, I. N., Yim, S., and Tran, T. (2011). Case study of concrete bridge subjected to
555 hurricane storm surge and wave action. *Solutions to Coastal Disasters 2011 - Proceedings*

556 of the 2011 Solutions to Coastal Disasters Conference, 728–739.

557 Seiffert, B., Hayatdavoodi, M., and Ertekin, R. C. (2014). Experiments and computations of
558 solitary-wave forces on a coastal-bridge deck. Part I: Flat plate. *Coastal Engineering*, 88,
559 194–209.

560 Seiffert, B. R. (2014). *Tsunami and Storm Wave Impacts on Coastal Bridges*. PhD thesis,
561 University of Hawai'i at Manoa, US.

562 Seiffert, B. R., Cengiz Ertekin, R., and Robertson, I. N. (2016). Effect of Entrapped Air on
563 Solitary Wave Forces on a Coastal Bridge Deck with Girders. *Journal of Bridge*
564 *Engineering*, 21(2), 4015036.

565 Seiffert, B. R., Ertekin, R. C., and Robertson, I. N. (2015). Wave loads on a coastal bridge deck
566 and the role of entrapped air. *Applied Ocean Research*, 53, 91–106.

567 Sherstinsky, A. (2020). Fundamentals of Recurrent Neural Network (RNN) and Long Short-
568 Term Memory (LSTM) network. *Physica D: Nonlinear Phenomena*, 404, 132306.

569 Wang, J., Xue, S., and Xu, G. (2021). A hybrid surrogate model for the prediction of solitary
570 wave forces on the coastal bridge decks. *Infrastructures*, 6(12), 170.

571 Weiss, K., Khoshgoftaar, T. M., and Wang, D. D. (2016). A survey of transfer learning. *Journal*
572 *of Big Data*, 3(1), 1–40.

573 Xiang, T., and Istrati, D. (2021). Assessment of extreme wave impact on coastal decks with
574 different geometries via the arbitrary lagrangian-eulerian method. *Journal of Marine*
575 *Science and Engineering*, 9(12), 1342.

576 Xiao, H., and Huang, W. (2008). Numerical modeling of wave runup and forces on an idealized
577 beachfront house. *Ocean Engineering*, 35(1), 106–116.

578 Xu, G., Wei, H., Xue, S., Wang, J., and Li, Y. (2022). Predicting wave forces on coastal bridges
579 using genetic algorithm enhanced ensemble learning framework. *Ocean Engineering*, 266,
580 112963.

581 Xu, Y., Øiseth, O., and Moan, T. (2018). Time domain simulations of wind- and wave-induced
582 load effects on a three-span suspension bridge with two floating pylons. *Marine Structures*,
583 58, 434–452.

584 Yuan, P., Zhu, D., and Dong, Y. (2021). Spatial failure mechanism of coastal bridges under
585 extreme waves using high-efficient pseudo-fluid-structure interaction solution scheme.
586 *Ocean Engineering*, 240, 109894.

587 Zhang, J., Zhu, B., Kang, A., Yin, R., Li, X., and Huang, B. (2020). Experimental and
588 numerical investigation of wave-current forces on coastal bridge superstructures with box
589 girders. *Advances in Structural Engineering*, 23(7), 1438–1453.

590 Zhang, W., Li, H., Li, Y., Liu, H., Chen, Y., and Ding, X. (2021). Application of deep learning
591 algorithms in geotechnical engineering: a short critical review. *Artificial Intelligence*
592 *Review*, 54(8), 5633–5673.

593 Zhu, D., and Dong, Y. (2020). Experimental and 3D numerical investigation of solitary wave
594 forces on coastal bridges. *Ocean Engineering*, 209, 107499.

595 Zhu, D., Dong, Y., and Frangopol, D. M. (2022). Experimental and numerical investigation on
596 wave impacts on box-girder bridges. *Structure and Infrastructure Engineering*, 18(10–
597 11), 1379–1397.

598 Zhu, D., Li, Y., and Dong, Y. (2021). Reliability-based retrofit assessment of coastal bridges
599 subjected to wave forces using 3D CFD simulation and metamodeling. *Civil Engineering*
600 *and Environmental Systems*, 38(1), 59–83.

601 Zhu, D., Yuan, P., and Dong, Y. (2021). Probabilistic performance of coastal bridges under
602 hurricane waves using experimental and 3D numerical investigations. *Engineering*
603 *Structures*, 242, 112493.

604