



HAL
open science

Introduction of a Cobot as intermittent haptic contact interfaces in virtual reality

Vamsi Krishna Guda, Stanley Mugisha, Christine Chevallereau, Damien Chablat

► **To cite this version:**

Vamsi Krishna Guda, Stanley Mugisha, Christine Chevallereau, Damien Chablat. Introduction of a Cobot as intermittent haptic contact interfaces in virtual reality. 25TH INTERNATIONAL CONFERENCE ON HUMAN-COMPUTER INTERACTION, In press. hal-04055526

HAL Id: hal-04055526

<https://hal.science/hal-04055526>

Submitted on 4 Apr 2023

HAL is a multi-disciplinary open access archive for the deposit and dissemination of scientific research documents, whether they are published or not. The documents may come from teaching and research institutions in France or abroad, or from public or private research centers.

L'archive ouverte pluridisciplinaire **HAL**, est destinée au dépôt et à la diffusion de documents scientifiques de niveau recherche, publiés ou non, émanant des établissements d'enseignement et de recherche français ou étrangers, des laboratoires publics ou privés.

Introduction of a Cobot as intermittent haptic contact interfaces in virtual reality

V.K Guda, S. Mugisha, C. Chevallereau, D. Chablat

Nantes Université, École Centrale Nantes, CNRS, LS2N, UMR 6004,
44000 Nantes, France *damien.chablat@cnrs.fr*

Abstract. Virtual reality (VR) is evolving and being used in industrial simulations, but the possibility to touch objects is missing, for example, to judge the perceived quality in the design of a car. Current haptic interfaces do not make it possible to easily restore texture, therefore an approach is considered as an intermittent contact interface to achieve this. A cobot places a moving surface at the point of contact with a virtual object in order to enable physical contact with the hand of the operator. This paper aims to speak about several challenges: the placement of the robot, the modeling of the operator, the management of the displacement and the speed of the robot, and the detection of the operator's intentions. The placement of the robot is chosen to allow reaching the different working areas and to ensure passive safety by making it impossible for the robot to hit the head and chest of the operator in a normal working position, i.e. sitting in a chair. A user model, consisting of a torso and arms, is designed and tested to track the user's movements in real-time. Interaction is possible with a set of pre-defined poses that the user follows together as desired. Various strategies are proposed to predict the intent of the user. The main aspects of prediction are based on the direction of the eye and the position of the hand of the user. An experimental study as well as the resulting analysis demonstrates the contribution by considering the direction of the gaze. The advantage of introducing "safety" points to move the robot away from the operator and allow rapid movements of the robot is emphasized.

Keywords: Safety, intermittent contact interface, human intention prediction, trajectory planning, human-robot collaboration, virtual reality.

1 Introduction

Virtual reality technologies allow a user to get immersed in virtual worlds. Haptic technologies born from robotics have increased the immersion in these virtual worlds by providing the sensation of touch.

In a Virtual Reality (VR) simulation, haptic interfaces allow a tangible and physical interaction with the virtual environment, but they must generally be constantly held in hand by the user and therefore do not allow objects to be touched in a natural way. At the same time, many applications require hands-on

interaction without intermediaries. This is particularly the case for simulations that require tactile exploration of the physical properties of virtual objects.

Classical force feedback interfaces, also called here classic contact haptic interfaces (CHIs), are robotic systems allowing natural motion interactions with virtual or remote environments. They are used in several domains such as design, manufacturing, assembly, scientific visualization, entertainment, education, medicine, space, rehabilitation, micro manipulation and molecular biology. In all cases, they should provide adequate kinesthetic (force) feedback, contributing to enhance the sense of presence in the virtual environment.

With CHIs, the user is usually mechanically linked to the device's end-effector, typically a handle, whose movements, measured by the robot, are used to know the configuration (position and orientation) of his/her hand. This information is necessary to provide force feedback which is consistent with the virtual scene and the mechanical properties of the virtual object (VO) being touched. The mechanical link that is established when the user manipulates the haptic device has however a non-negligible influence since he/she experiences the friction, inertia and vibrations of the mechanical structure, even in free space where he/she is expected to feel nothing. Such unwanted sensations decrease the realism of the interaction since the user feels all the time the presence of the robot. In addition, the difference between free space and contact is less distinctively felt than in the real world.

In order to cope with these issues, several efforts can be made in terms of mechanical design, e.g. use of very lightweight and very stiff structures (even if an optimal trade off is difficult to attain) and more efficient transmission systems. Another approach consists in installing a force sensor at the level of the robot's end-effector in order to measure and compensate any resisting force in the direction of displacement. However, resisting forces can never be totally canceled and none of these approaches completely eliminates the feeling of the presence of the robot in free space.

Years of research on haptics, robotics, and interaction in VR have led to the development of a new generation of haptic devices called intermittent contact interfaces (ICI) [1],[2],[3]. Intermittent-contact interfaces (ICIs) represent an original and promising approach aiming to cope with the aforementioned issues. Its principle consists in removing the mechanical link between the human operator and the force feedback interface during manipulations in free space and come at his/her contact only when force feedback is required. This solution implies the need to track and closely follow the user's movements in free space and to prevent him/her to move in the constraint direction when a VO is being touched. This way, the user doesn't feel any force in free space (perfect transparency) and the transitions from free space to contact are deemed to be felt more naturally as the robot really touches the user at the simulated contact moment. This approach aims to improve the realism of the interactions, however it suffers from several shortcomings. First, its efficiency has not yet been proven in terms of user safety. Second, even if IC interfaces are experimentally proven to be stable at low speeds, they tend to become oscillating at higher speeds.

Finally, despite the fact that a lot of tasks are performed by the mean of tools in the real world, most of existing ICIs focus on bare finger interactions and are therefore not optimal for simulating tool-mediated tasks.

User safety is central to the implementation of an ICI. To satisfy this constraint, we propose to use a cobot, for which we will develop specific path planning algorithms taking into account its low performance in terms of travel speed in the intrinsically safe mode, as well as all segments of the robot and the user's entire body in interference management. These algorithms will be based on a user activity prediction model that will allow both specifying a final desired location and the constraints to be respected when defining the path to reach this desired location.

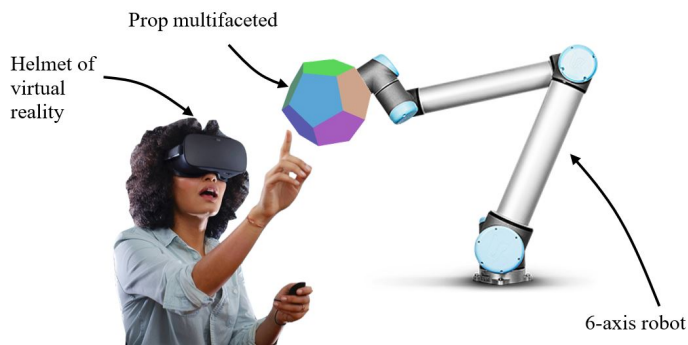

Fig. 1: Conceptual scheme of the experimental platform

This paper summarizes the contribution of [4] which introduces a series of research works aiming to leverage the usability of such a system. This research work is created to deal with the present limits in such a haptic device system.

2 Description of context

This work was developed under the frame of the French National Research Agency (ANR) LobbyBot Project. The LobbyBot project consisted in developing a system that could be integrated into an industrial application for automotive interior prototyping. The system is intended to be used to recreate an automotive cockpit for faster prototyping in VR for the Renault Group, a French automotive company. In this fast prototyping process, designers had to explore and evaluate the perceived quality of a virtual car interior with their sense of touch of different materials, shapes, and objects that could be arranged in a virtual automotive interior that could be easily configured in VR. This new paradigm was conceived as a means to save the Renault Group costs in budget and time for fabricating actual automotive cockpits that are exclusively used for

prototyping purposes. The purpose of this project is the control of the robot to implement this ICI.



Fig. 2: The LobbyBot project setup.

Interaction techniques will allow managing any delays by the ICI in relation to the user. To increase the extent of sense of the form and materials can be restored by the use of an adapted pseudo-haptic return, and to follow a surface with the finger through appropriate sensory feedback. The integration of all the results into an ICI prototype will make it possible to validate the interest of the solution on an industrial case study. With current technologies, this industrial application (evaluation of the perceived quality of a virtual car interior) cannot be treated in a fast and low cost way.

3 Applications of ICIs

ICI applications range from industry (Figure 3a), entertainment (Figure 3b), medicine (Figure 3c), and research purposes (Figure 3d). In all these cases, users expect to “encounter” a surface to touch or manipulate in a Virtual Environment. In the case of industrial applications, these devices are considered for virtual prototyping that requires to have haptic feedback in several locations to recreate workspace or expected location for objects to be manipulated. In the case of entertainment, they are used to recreate elements that can come in contact with the users when interacting with a virtual environment [5]. In the case of medicine, its often used for remote body-palpation and surgery practice [6]. The use in research purposes often looks for leveraging the device’s capabilities for rendering more complex surfaces and objects [7].

4 Challenges

In order to leverage the capabilities of ICI, several challenges must be addressed, these are addressed in different dimensions such as: **User safety and security**



(a) Application in Industry by Lobbybot [8].

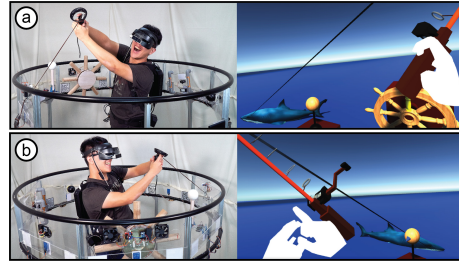

(b) Haptic-go-round from one direction to another while fishing in the virtual scene. [5].



(c) The virtual palpation system. [6].

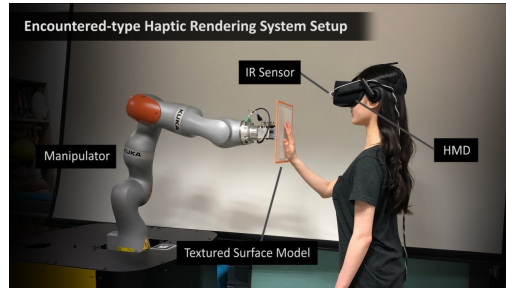

(d) Synthesizing the Roughness of Textured Surfaces for an Encountered-type Haptic Display [7].

Fig. 3: ICI applications

and **User immersion experience**. The challenges are divided into research questions.

Challenge 1. User safety and security

The concern to avoid unexpected collisions with users has been present ever since the early days of Human-Robot Interaction research. Measures for addressing this issue normally consider path-planning algorithms that help the robot to actively avoid the user in cases where both user and device could come into contact involuntarily. However, the use of path-planning often causes the device to move more slowly. This delay affects response time and user's perceived immersion in the virtual environment, and thus, it has been recognized as an issue to be addressed by the research community.

As an alternative to solutions exclusively relying on path-planning for avoiding collisions with users, we propose additional techniques like the placement of robot to minimize the workspace interaction, and creation of multiple zones for robot motion. Research concerning user safety for ICI systems needs to look for strategies that help to avoid any undesired contact that could break users

perceived immersion in the virtual environment. The main objective remains to ensure the safety of the operator. With virtual reality, the operator has a modified perception of the robot and of the risk of collision. A visualization in the virtual world of the robot reduces the immersion but increases the safety. In the intersection zones between the space possibly scanned by the robot and the human, the robot (UR5) will be placed in cobot mode, i.e. it will stop and switch to gravity compensation mode if a contact effort is detected. Thus it cannot injure the operator. However, the speed of the robot is then limited.

Research Question 1. Robot placement Robot placement holds the promise of removing the need for a highly dedicated and structured workspace, as well as responding more quickly to environmental changes. Within the systems, dynamic and robust placements are crucial and strategically important, since they are often done in early stages in the process.

A complete set of operations consists in performing a specific task/operation by a robot on a set of task points. Often, after the robot returns to its starting configuration, a user is introduced to the system, and operations are performed. Since these cycles are repeated several times, it is very important that they are executed as fast as possible in order to increase immersion.

Once a set of specific points is assigned to a robot, the layout has limited freedom to optimize the robot workstation:

- robot’s base placement (translation and rotation); The orientation of robot TCP at each task points is important as it effects the immersion of the user. So the robot should be able to reach the task points with the required orientations. The study started with no information on the robot base location in the virtual environment.
- visiting order of the work-points; In this approach the user decides the order of interaction with the task points. To improve user safety , the robot has to be closer to the user hands near the task points and as far as possible to the human body (torso, head and especially neck). Major concerns were to restrict the operation of the robot to one aspect to avoid crossing singularities while performing the tasks.
- robot’s home configuration in the station (six joints); initial approach is to achieve one single base location and have single aspect of robot to connect and move between all the task point.

The last three ones may be modified by changing the robot program, whereas the first has to be completely decided before installing the robot in the workspace.

Research Question 2. User model There is no fixed technique or standard procedure to use a tracking system to explore user actions in VR. Human movement tracking systems are expected to generate real-time data that dynamically represent the pose changes of a human body (or a part of it), based on well-developed motion sensor technologies. Generic tracking systems employed within

these systems adhere to the human body in order to collect movement information. These sensors are commonly categorized as mechanical, inertial, acoustic, radio, microwave, and magnetic-based. In such systems, the user is generally equipped with sensors on his hands, that give the sense of interacting with a virtual object. Additionally, these sensors don't give information about the position and orientation of the user's location in the system. Visual marker-based tracking is a technique where cameras are applied to track human movements, with identifiers placed upon the human body.

The whole idea of ICI is to increase immersion and remove the sensation of robot presence in free space. Since the robot has the plan to move between task points without colliding with the user. For safety concerns, the position of the user is very important. However, we cannot have complex tracking systems to locate the user. Normally the use of external cameras and markers are used to locate the user's position. But such systems increase the number of sensors attached to the user, which reduces the immersion. So the goal is to use less additional sensors as possible to give the best immersion experiences while getting the accurate location of the user for planning trajectories of the robot.

Challenge 2. User immersion experience

Haptic feedback for ICIs goal is to improve the immersion experience of users. The major idea is to eliminate the mechanical link so as to have perfect transparency in free space. But even trying to achieve this experience comes with the challenges like planning the robot motion between the VO being touched (without colliding with the user), and predicting which VO object the user intends to touch in the environment.

Research Question 3. Robot motion planning In the given scenario the user is immersed in Virtual reality. The user has no information regarding the motion of the robot. The robot's motion has to be safe for the user, experiencing the VR environment. It should avoid collision with the user and also any other obstacles in the environment. The robot's motion should take into consideration collision with the user based on the tracking system used. It's not only for the user's safety, but also to have a better immersion of the user, the robot must place a real object at the place where the user wants to touch the VO as quickly as possible, and before the user's hand reach the contact location.

Research Question 4. Target object detection. Since they touch the user only when force feedback is required, intermittent contact interfaces, and in particular close-tracking-type devices, aim to provide more realistic interactions with virtual environments than classical contact haptic interfaces (CHI). User intention prediction in ICI remains a challenge to be properly addressed by the research community.

Previous systems force the user to interact with the VO, selected by it. These systems have to use control algorithms and interaction techniques to make the

haptic rendering as efficient as possible. For the new system, we want to give the user freedom to select the VO to interact and the robot system should adapt to align itself w.r.t to the VO. The goal of such a system is to predict the VO the user wants to interact with as soon as possible. However, for these new systems, the two solutions (control algorithms and interaction techniques) are not enough to render the haptic sensation.

5 Roadmap for the introduction of cobots

The main research area considered as a contribution to this work is improving user safety and immersive experience for users of a ICI haptic device in human-robot interaction.

The user safety axis is improved by addressing four contributions. The first contribution (C1) consists of a set of safety techniques based on robot placement. The second (C2) creation of a user model for tracking user information, and the third (C3) techniques for robot trajectory planning. Then, the second axis immersive experience is improved by making sure the user does not lose the illusion of the environment. This aspect can be addressed by making sure the user does not wait a long time for the robot to reach the desired interactive location. This is achieved by addressing 2 contributions, the first contribution (C3) techniques in robot trajectory planning and the second contribution (C4) techniques for user goal predictions, designed to optimize the response time in ICI systems.

The relationship between the contributions and the research axis can be seen in Table 1.

Contribution	User safety	Immersive experience
(C1) Safety techniques based on robot placement.	x	
(C2) User model for tracking user information.	x	
(C3) Techniques for robot trajectory planning.	x	x
(C4) Techniques for user goal predictions.		x

Table 1: Contributions to the research axis

A set of safety techniques for users based on robot positioning (C1) was presented in [9]. In this paper, a design space for safety techniques was introduced using visuals restricting the interactive workspace of the robot and the user, in order to reduce potential unintended collisions. The dimensions of the workspace are defined by where the user wants to interact with the virtual environment as well as to ensure the safety of the user. Using this design of robot placement, a set of workspaces was developed to explore variations of the prop orientations. An evaluation focusing on the best solution for robot placement is done. Safety was

evaluated and the ideal location of the robot was defined. The main constraint is that the robot end effector cannot touch the user’s head (Figure 4).

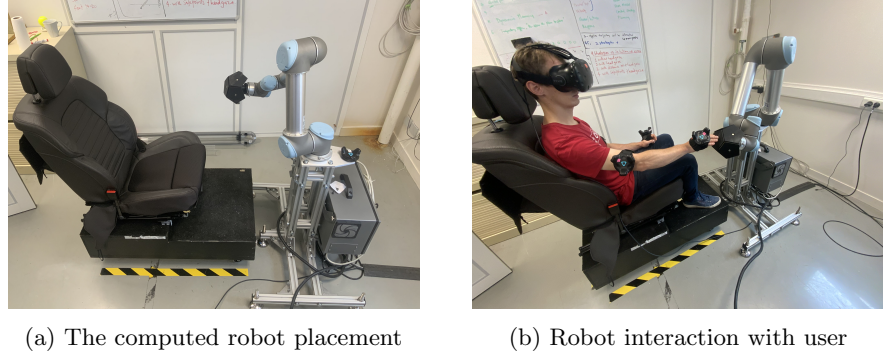

Fig. 4: Placement analysis of the base table of the robot.

The model was designed to estimate the user location in the Robot Operating System (ROS) environment [4]. The model created had to have features such as movement of both arms and also the mobility of the user around the hip. These major three moving parts provided better information about the user’s location, improving the user’s safety in using an ICI system. A user study was designed to assess and test the performance of these motions to test the accuracy and reliability of creating a user model. Results suggested that the model is accurate for the given scenario in locating the user in the environment. Only five sensors are needed to have a good representation of the upper limbs of the user (Figure 5). This property allows a simplified set up of users while guaranteeing their safety.

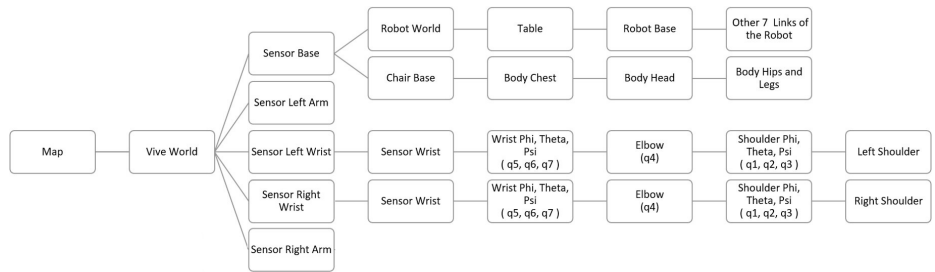

Fig. 5: Structure for both arms to evaluate the joint position of the arms q_i , the position of the hands, and the base position of the robot.

The helmet also adds additional information. The integration of the ROS node into the Unity simulation requires the implementation of a system architecture with elements under Windows and others under Linux (Figure 6).

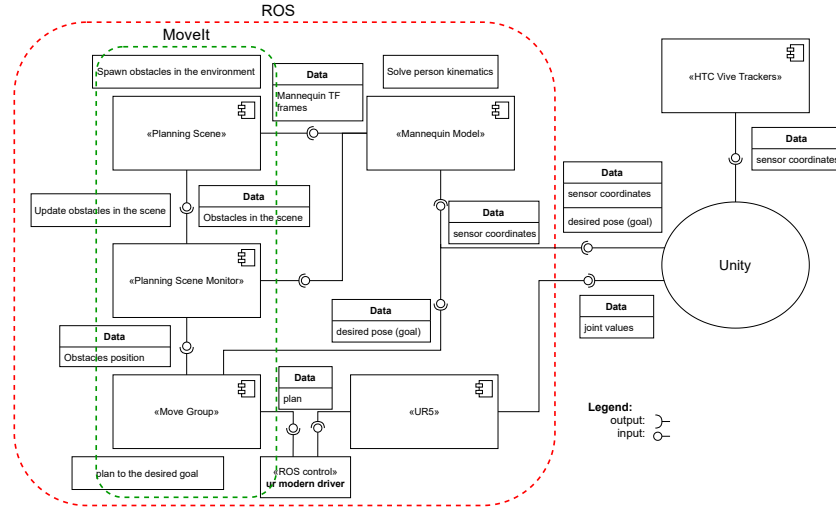

Fig. 6: System's Architecture.

An approach for the trajectory planning of robots was introduced in [10]. The goal is to increase the immersive experience (C3) by reducing the time taken by the robot to reach the contact area. This approach renders large surfaces and multiple textures through the use of a rotating prop, that couples the prop's rotation and position with the users' hand position when exploring a textured surface in VR. A use-case scenario was designed for contextualizing this approach. Later, a user study was conducted to validate the approach haptic rendering performance. A novel approach for the prediction of user intention based on head gaze and hand position was introduced in [11] (Figure 7).

Four strategies are presented to predict where the user wants to interact with the virtual environment (C4) [11] (Figure 8). The strategies include the hand position (A), the hand position and the gaze direction (B), the hand position and safe point to allow faster motions (C), and the hand position, the gaze direction, and the safe point to allow faster motions.

Each approach presented is evaluated on four key features: (1) time taken to prediction, (2) time taken by the robot to reach the contact area, (3) distance traveled by the robot, and (4) safety of the user. These approaches integrate an interaction technique for contact area selection and release.

A comparative analysis of data from all the trajectories shows that, if the objective is to maximize safety strategies (C) and (D) would be better. Both strategies (C) and (D) ensure safety by selecting safe points when the hand is

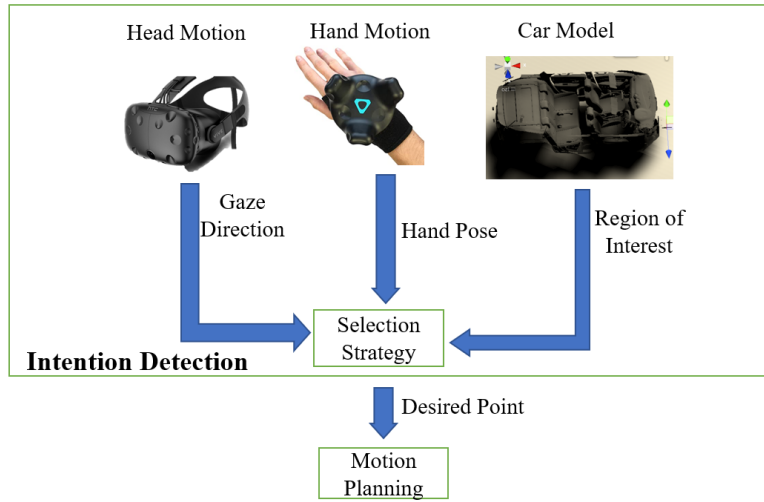

Fig. 7: Diagram of the inputs used to choose a robot movement strategy, hand, and head position with the gaze direction.

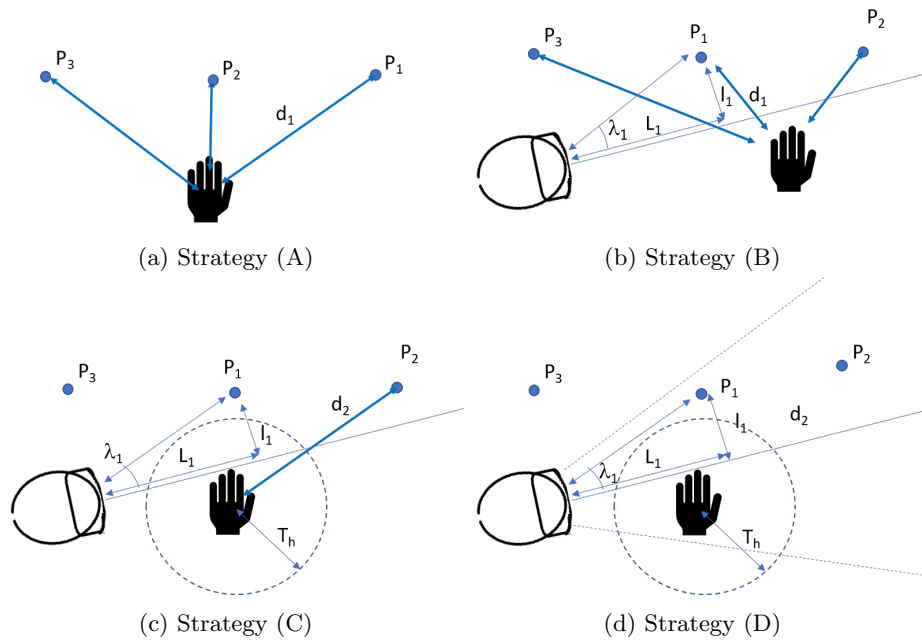

Fig. 8: Four strategies to detect human intention

far away from the desired point. The safe points are located outside the user’s reach, such that the robot can travel fast and does not collide with the user. The selection of the safe points means that the robot will have to travel a longer distance to reach the desired point. While strategies (A) and (B) select intermediate points that are inside the car and there are no safe points. So since the points are all inside the car, and the robot does not travel longer distances but has reduced velocity. Strategy (D) gives the second-best safety and, at the same time minimize, the time to detect/reach a desired point. Therefore it can be seen as the best strategy. The detection time for strategy (D) is the smallest because we used the gaze of the user to pre-select the points. This plays an important role in giving priority to visual information over information from the hand position. The fastest detection time allows the robot to start moving to the desired point at the earliest time and reach the desired point the fastest.

A simple real-time demonstration of the above system using strategy (D) can be found here ¹.

6 Conclusions and future work

This paper summarized the context of the introduction of cobot for the implementation of a haptic interface with intermittent contact. The different challenges were presented in order to guarantee the safety of the user and improve the user’s immersion. The various stages presented are invariants to be considered for the implementation of similar experiences.

A work of diffusion remains to be done to put on GitHub the functions allowing to define the optimal placement of the robot, the generation of trajectories according to the environment, the position of the user, and his intention for new applications. Moreover, a transfer of the software to ROS2 could improve security by guaranteeing the real-time aspect of the information exchanges.

Acknowledgment

This work was funded under the LobbyBot project: Novel encountered type haptic devices, ANR-17-CE33 [21]. The authors of the article thank the members of the project for their help in carrying out this work, Lionel Dominjon, Sandrine Wullens, Alexandre Bouchet, Javier Posselt, Maud Marchal, Anatol Lecuyer and Victor Rodrigo Mercado Garcia.

References

1. Y. Kim, H. J. Kim, and Y. J. Kim, “Encountered-type haptic display for large vr environment using per-plane reachability maps,” *Computer Animation and Virtual Worlds*, vol. 29, no. 3-4, p. e1814, 2018.

¹ <https://www.youtube.com/watch?v=wz0dJjk4-qk>

2. W. A. McNeely, "Robotic graphics: a new approach to force feedback for virtual reality," in *Proceedings of IEEE Virtual Reality Annual International Symposium*. IEEE, 1993, pp. 336–341.
3. B. Araujo, R. Jota, V. Perumal, J. X. Yao, K. Singh, and D. Wigdor, "Snake charmer: Physically enabling virtual objects," in *Proceedings of the TEI'16: Tenth International Conference on Tangible, Embedded, and Embodied Interaction*. ACM, 2016, pp. 218–226.
4. V. Guda, "Contributions to utilize a cobot as intermittent contact haptic interfaces in virtual reality," Ph.D. dissertation, Ecole Centrale de Nantes, 2022.
5. H.-Y. Huang, C.-W. Ning, P.-Y. Wang, J.-H. Cheng, and L.-P. Cheng, "Haptic-go-round: A surrounding platform for encounter-type haptics in virtual reality experiences," in *Proceedings of the 2020 CHI Conference on Human Factors in Computing Systems*, ser. CHI '20. New York, NY, USA: Association for Computing Machinery, 2020, pp. 1–10. [Online]. Available: <https://doi.org/10.1145/3313831.3376476>
6. A. Filippeschi, F. Brizzi, E. Ruffaldi, J. M. Jacinto, and C. A. Avizzano, "Encountered-type haptic interface for virtual interaction with real objects based on implicit surface haptic rendering for remote palpation," in *2015 IEEE/RSJ International Conference on Intelligent Robots and Systems (IROS)*. IEEE, 2015, pp. 5904–5909.
7. Y. Kim, S. Kim, U. Oh, and Y. J. Kim, "Synthesizing the roughness of textured surfaces for an encountered-type haptic display using spatiotemporal encoding," *IEEE Transactions on Haptics*, vol. 14, no. 1, pp. 32–43, 2020.
8. J. Posselt, L. Dominjon, B. A. A., and K. A., "Toward virtual touch: investigating encounter-type haptics for perceived quality assessment in the automotive industry," in *Proceedings of the 14th annual EuroVR conference*, 2017, pp. 11–13.
9. V. Guda, D. Chablat, and C. Chevallereau, "Safety in a human robot interactive: Application to haptic perception," *Chen J.Y.C., Fragomeni G. (eds) Virtual, Augmented and Mixed Reality. Design and Interaction. HCII 2020. Lecture Notes in Computer Science*, vol. 12190, pp. 562–574, 2020.
10. A. Gutierrez, V. K. Guda, S. Mugisha, C. Chevallereau, and D. Chablat, "Trajectory planning in dynamics environment: application for haptic perception in safe human-robot interaction," in *Digital Human Modeling and Applications in Health, Safety, Ergonomics and Risk Management. Health, Operations Management, and Design: 13th International Conference, DHM 2022, Held as Part of the 24th HCI International Conference, HCII 2022, Virtual Event, June 26–July 1, 2022, Proceedings, Part II*. Springer, 2022, pp. 313–328.
11. V. Guda, S. Mugisha, C. Chevallereau, M. Zoppi, R. Molfino, and D. Chablat, "Motion strategies for a cobot in a context of intermittent haptic interface," *Journal of Mechanisms and Robotics*, vol. 14, no. 4, p. 041012, 2022.