



HAL
open science

Multi-Objective Optimization of an Industrial Isoprene Production Unit by Using Genetic Algorithm Approach

Rita M. B. Alves, Claudio A. O. Nascimento, Luiz V. Loureiro, Pascal Floquet,
Xavier Joulia

► **To cite this version:**

Rita M. B. Alves, Claudio A. O. Nascimento, Luiz V. Loureiro, Pascal Floquet, Xavier Joulia. Multi-Objective Optimization of an Industrial Isoprene Production Unit by Using Genetic Algorithm Approach. 15th European Symposium on Computer-Aided Process Engineering ESCAPE-15, May 2005, Barcelona, Spain. pp.211-216. <hal-04041017>

HAL Id: hal-04041017

<https://hal.science/hal-04041017v1>

Submitted on 22 Mar 2023

HAL is a multi-disciplinary open access archive for the deposit and dissemination of scientific research documents, whether they are published or not. The documents may come from teaching and research institutions in France or abroad, or from public or private research centers.

L'archive ouverte pluridisciplinaire **HAL**, est destinée au dépôt et à la diffusion de documents scientifiques de niveau recherche, publiés ou non, émanant des établissements d'enseignement et de recherche français ou étrangers, des laboratoires publics ou privés.



HAL Authorization

Multi-Objective Optimization of an Industrial Isoprene Production Unit by Using Genetic Algorithm Approach

Rita M. B. Alves^{a1}, Claudio A. O. Nascimento^a, Luiz V. Loureiro^a, Pascal Floquet^b,
Xavier Joulia^b

^aCESQ – Centro de Engenharia de Sistemas Químicos

Department of Chemical Engineering, Polytechnic School, University of São Paulo
Av. Prof. Luciano Gualberto, n. 380, trav. 3, 05508-900, São Paulo - SP, Brazil
Telephone number: + 55 11 3818-2237; Fax number: + 55 11 3813-2380

E-mail: rita@lscp.pqi.ep.usp.br; oller@usp.br

^bLGC-Chemical Engineering Laboratory - UMR CNRS/INP/UPS 5503 - ENSIACET
118 route de Narbonne 31077 Toulouse Cedex 4, France

Telephone number: + 33 5 62885830; Fax number: + 33 5 62885600

E-mail: Pascal.Floquet@ensiacet.fr; Xavier.Joulia@ensiacet.fr

Abstract

The present work deals with the multi-objective optimization of an industrial Isoprene production unit by using Genetic Algorithm (GA). The chemical process consists basically of a dimerization reactor and a separation column train. The GA-search was chosen as an optimization tool because of their successful application in many industrial optimization problems (Alves et al., 2004; Laquerbe et al., 2001; Pibouleau et al., 1999). Then, the aim of this paper is to present and discuss the applicability of a GA as an alternative procedure for a multi-objective optimization of an industrial process that may be difficult to handle by classical methods. In this case the optimization of the entire plant involves 21 variables to be optimized. So, in order to decrease the dimensionality of the problem, the global model was divided into three sections and each one was optimized separately, but sequentially, by using the optimal conditions from previous optimization section procedure. For this, a multi-objective genetic algorithm (MOGA) based on a Pareto sort (PS) procedure was implemented to manage this specific problem.

Keywords: Genetic Algorithm, Multi-Objective Optimization, Isoprene

1. Introduction

When an optimization problem involves multiple objective functions, case of the most real-world search and optimization problems, the task of finding one or more optimum solutions is known as multi-objective optimization. In this way, different solutions may produce conflicting scenarios among different objectives. A solution that is extreme with respect to one objective requires a compromise in others objectives (Deb, 2002).

¹ Author to whom correspondence should be addressed: rita@lscp.pqi.ep.usp.br

Thus, in problems with more than one conflicting objectives, there is no single optimum solution, but it exists a number of solutions that are all optimal and it is not simple to judge one set of optimal solutions better than any other. Then, it is necessary to introduce some further, non-technical and/or qualitative information and personal experience. From this way, it is possible, in a multi-objective optimization, to find multiple sets of optimal solutions by considering all the important objectives and, after, by using additional information, to choose one solution among all solutions obtained (Deb, 2002).

To find multiple optimal solutions in one single simulation run makes Evolutionary Algorithm (EA) an important tool to solve multi-objective optimization problems and for this reason, over the last decade, genetic algorithms (GAs) have been extensively used as search and optimization tools in various problem domains, including the sciences, commerce and engineering. The primary reasons for their success are their broad applicability, ease using and global perspective (Goldberg, 1989). Moreover, GAs may find a solution near the global optimum within reasonable time and computational costs. For this, the aim of this paper is to present and discuss the applicability of a multi objective genetic algorithm (MOGA) based on Pareto sort (PS) for a multi-objective optimization of an industrial process that may be difficult to handle by classical methods and for which formal objective functions can not be applied.

2. Implementation of a Genetic Algorithm for Process Optimization

The scheme of optimization is shown in the Figure 1. In this work, a real-parameter coded genetic algorithm was used, so a chromosome is a vector of floating point numbers whose size is kept the same as the length of the vector, which is the solution to the problem. Random generation was the procedure chosen to create the initial population. This strategy guarantees a population able to vary enough to explore the entire range of the search space. The feasibility of each individual of this population is evaluated in order to verify constraint violations, before being integrated into the population to be used in the MOGA procedure. This population is then called feasible population. A neural network model (Alves, 2003, Alves et Nascimento, 2004) was previously developed in order to model and simulate the process. This work was used as reference for this study and the built model is the evaluation function used to represent the system.

Once a population of solutions is created, it is necessary to evaluate the solution in the context of the underlying objective functions and a fitness value or domination value is assigned to each individual. In other words, given a particular chromosome, a solution, the fitness function returns a single numerical fitness, which is supposed to be proportional to the utility or adaptation of the solution. In this case, the Pareto domination conception was used in order to define in a way that a solution x_1 is said to dominate the other solution x_2 (Deb, 2002). Thus the feasible objective space contains Pareto- optimal solutions (the non-dominated set) and non-Pareto optimal solutions (the dominated set). Then, it is clear that in multi-objective optimization, the task is to find as many Pareto-optimal solutions as possible in a problem. In this work it was implemented the sorting procedure as proposed by Massebeuf (2000).

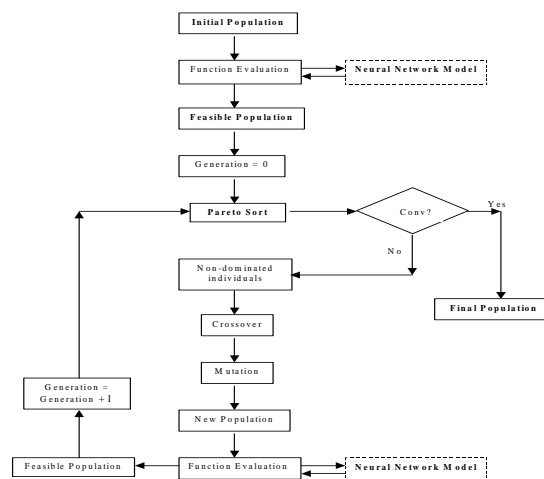

Figure 1. Scheme of Optimization Procedure

Once the best individuals, i.e., the non-dominated set, are determined, it is possible to apply the genetic operators: crossover and mutation. But before carrying out these operators, in this work, it was proposed to keep these best individuals from one generation to the next without being modified by the genetic operators. Then crossover operator was then used to create two new individuals by swapping all characters between two parents chromosomes positions. From this way, it was possible to diversify the population of the new generation. This procedure was repeated until the number of new and different individuals created achieves the size of the initial population. It is expected the new solutions or individuals generated by crossover operator will be better than both of the original individuals or parents. After the mutation operator was applied on the new population. Mutation is the occasional random alteration of the value of a chromosome position (gene) that prevents the premature convergence of GA to sub optimal solutions and ensures that the probability of reaching any point in the search space is never zero (Herrera et al., 1998). The mutation rate used was 1%. Finally, the stop criterion assigns the end of the procedure. The criterion considered in this study is that all individuals of one generation will be non-dominated in the Pareto Sort procedure.

3. Optimization of Isoprene Production Unit

The system studied is the Isoprene Production Unit from BRASKEM, the largest Brazilian petrochemical plant. An extractive distillation process is used to perform the isoprene production. The process of isoprene production can be basically divided into three sections: feed preparation, extractive distillation and solvent recovery and fractionating. Figure 2 shows schematically this process. The Isoprene industrial process is a complex process, and it is not easy to be solved by commercial simulators mainly due to the lack of thermodynamics properties. A neural network approach has

been previously developed in order to model this industrial process from historical data (Alves, 2003; Alves and Nascimento, 2004).

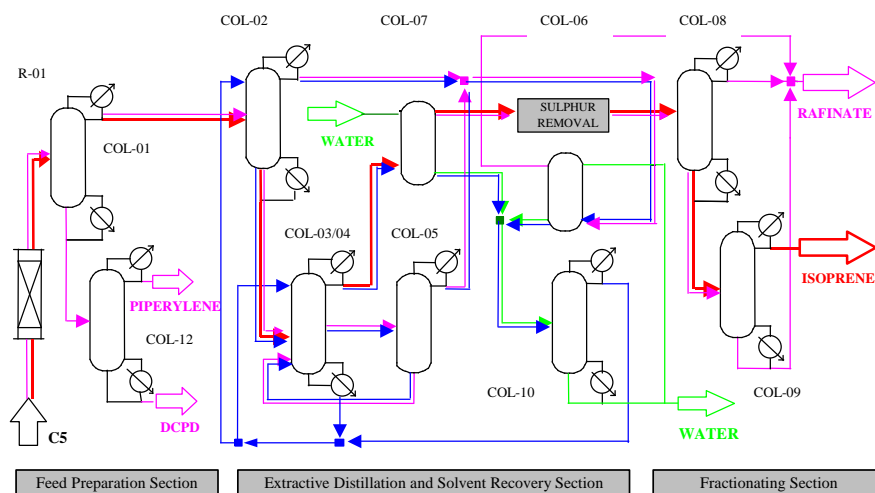

Figure 2. Isoprene Unit

The main objective of this work is to establish optimal operational conditions in order to obtain higher production of Isoprene within of the specifications defined by the costumers. The constraints of quality and safety required by the process and the variables to be optimized are shown in Table 1. All the units of the variables are arbitrary. The optimization of the entire plant involves 21 variables to be optimized. Then the global model was divided into parts in order to decrease the problem of dimensionality. Each part of the model was optimized separately, but sequentially using the optimal conditions from the previous optimization procedure, and of course this procedure do not assure to achieve the global optimal conditions. The division corresponds to the following sections: 1- Feed Preparation; 2- Extractive Distillation and Solvent Recovery; 3- Fractionating. The optimal values generated at each step of the optimization procedure were used as input data for the next step. Using the multi-objective genetic algorithm developed carried out the optimization procedure at each step. The choice of the constraints shown in the Table 1 has the following objectives: a) to specify the composition of CPD and 2M2B at the Feed Preparation Section in order to guarantee the specification of the final product; b) to concentrate IP at the Feed Preparation Section in order to feed the Extractive Distillation Section as required; c) to specify the temperature of the bottom of the Depentanizer Column in order to avoid degradation of DCPD; d) to specify the composition of 2-Butine and CPD at the distillate of the Second Extractive Distillation Column in order to guarantee the specification of the final product and; e) to specify the composition of Water at the top of the First Column of Solvent Recovery. The content of Water in the solvent circuit is a critical point of this unit. Depending of the main objective to be achieved, others constraints could be considered.

Notation	Variable Description	
Independent Variables		
x1(1)	Feed Flow of the Unit	
x1(4)	Feed Temperature of the Reactor	
x2(5)	Reflux Flow of the COL-01	
x2(6)	Vapor Flow for the Reboiler of the COL-01	
x3(2)	Reflux Flow of the COL-12	
x3(4)	Vapor Flow for the Reboiler of the COL-12	
x4(6)	Reflux Flow of the COL-02	
x4(5)	Solvent Flow for the COL-02	
x4(7)	Vapor Flow for the Reboiler of the COL-02	
x5(5)	Solvent Flow of the COL-03	
x5(6)	Reflux Flow of the COL-03	
x5(7)	Vapor Flow for the Reboiler of the COL-03	
x7(5)	Water Flow for the COL-07	
x7(6)	Water Flow for the COL-06	
x8(3)	Reflux Flow of the COL-10	
x8(4)	Vapor Flow for the Reboiler of the COL-10	
x9(3)	Reflux Flow of the COL-08	
x9(4)	Solvent Flow for the Reboiler of the COL-08	
x9(5)	Solvent Inlet Temperature - Reboiler of the COL-08	
x9(6)	Solvent Outlet Temperature - Reboiler of the COL-08	
x10(3)	Reflux Flow of the COL-09	
Constraints		
x1(3)-y1(2)	Composition of CPD at R-01 Outlet	< 4
x1(2)-y1(1)	IP Loss at R-01	< 4
y2(2)	Composition of IP at the distillate of the COL-01	> 23
y2(3)	Composition of CPD at the distillate of the COL-01	< 4
y2(4)	Composition of 2M2B at the distillate of the COL-01	< 2
y3(4)	Bottom Temperature - COL-12	< 120
y5(2)	Composition of Butene-2 at the distillate of the COL-03	< 2
y5(3)	Composition of CPD at the distillate of the COL-03	< 2
y8(3)	Composition of H2O at the distillate of the COL-10	< 23

Table 1. Variables and Constraints for the Process Optimization.

4. Results and Discussion

The first step is to create randomly an initial population of the variables of the feed preparation section. The purpose is to find the operational conditions, lowest reflux flow, lowest reboiler steam flow and lowest feed temperature, which could minimize the energy costs, i.e., conditions that lead to a less expensive operation. Low feed temperature is also important because it avoids dimerization reactions. Only the solutions, which satisfy some operational conditions are accepted. These conditions are CPD outlet concentration and IP loss from the reactor; IP, CPD and 2M2B (2-Methyl-2-Butene) concentrations in the overhead product from the distillation column and the temperature of the bottom of the depentanizer column. The final population of this first step of the optimization procedure is then considered input data for the next section optimization procedure, i.e., the extractive distillation and recovery solvent sections. For this second step, only the variables that do not come from the first section are generated randomly and optimized following the same procedure previously described. The requested process conditions are the lowest reflux flow, the lowest reboiler steam flow and the lowest temperatures. They are accepted in order to find the operational conditions that lead to less operational costs or less energy consumption. Once more time, the final population or optimal solutions of the second step of the optimization procedure is considered input for the third section, i.e. the fractionating section. In this case the operational conditions that lead to less operational costs or less energy consumption are the lowest reflux flow, the lowest reboiler steam and the lowest temperatures. Following this procedure, each set of optimal conditions (final population) from the previous step provided a new set of optimal conditions for the next optimization step.

As an example of the optimization result, it is possible to compare some operational conditions and optimal conditions obtained for a given condition of feed. It is possible

to obtain a reduction of 32% in the reflux flow and 26,5% in the reboiler steam at the Col-01. It is possible also a reduction of 11,5% - 18% in the solvent flow and 20% - 50% in the reflux flow at the Col-02.

5. Conclusion

GAs have had a great success in search and optimization problems. The reason is their ability to exploit the information accumulated about an initial unknown search space in order to bias subsequent searches into useful subspaces, i.e., their adaptation. This is particularly useful in large, discontinuous, complex, and poorly understood search spaces, where classical search tools are inappropriate, offering a valid approach to problems requiring efficient and effective search techniques. GAs can solve hard problems quickly and reliably and they are easy to interface to existing simulations and models. GAs do not guarantee to find the global optimum solution to problem, but they are generally good at finding acceptably good solutions near the global optimum within reasonable time and computational costs.

The case study presented shows of success the applicability of a genetic algorithm as an alternative procedure for a multi-objective optimization of industrial process that may be difficult to hand by classical methods.

References

- Alves, R.M.B., 2003, Otimização de um Processo Industrial de Produção de Isopreno via Redes Neurais, PhD Thesis, University of São Paulo, Brazil.
- Alves, R.M.B. and Nascimento, C.A.O., 2004, Neural Network Based Approach Applied for Modeling and Optimization of an Industrial Unit of Isoprene Production. Proceedings of AIChE Annual Meeting 2004, Austin-USA.
- Alves, R.M.B., Nascimento, C.A.O., Loureiro, L. V., Floquet, P., Joulia, X., 2004, Multi-Objective Optimization of Industrial Nylon 6,6 Polymerization Process in a Twin-Screw Extruder Reactor Using Genetic Algorithm Approach. Proceedings of CHISA 2004, Prague-Czech Republic
- Deb, K., 2002, Multi-Objective Optimization Using Evolutionary Algorithms, John Wiley & Sons, Ltd.
- Goldberg, D. E., 1989, Genetic Algorithms in Search, Optimization, and Machine Learning, Addison Wesley Longman, Inc., New York
- Herrera, F., Lozano, M. And Verdegay, J.L., 1998, Tackling Real-Coded Genetic Algorithms: Operators and Tools for Behavioural Analysis, Artificial Intelligence Review 12, pp. 265-319.
- Laquerbe C., Laborde J.C., Soares S., Floquet P., Pibouleau L., Domenech S., 2001, Synthesis of RTD Models via Stochastic Procedures: Simulated Annealing and Genetic Algorithm, Computers & Chem. Eng., Vol 25(9-10), pp. 1169-1183.
- Massebeuf, S., 2000, Optimisation Multicritère de Procédés Discontinus d'Homopolymérisation et de Copolymérisation en Émulsion, PhD Thesis, France
- Pibouleau L., Floquet P., Domenech S., Azzaro-Pantel C., 1999, A survey of Optimization Tools through ESCAPE Symposia, European Symposium on Computer Applications in Process Engineering - ESCAPE 9, Budapest, (Hongrie), Supplement to Comp. and Chem. Engineering, pp. S495-S498

Acknowledgments

The authors gratefully acknowledge FAPESP and CAPES/COFECUB for their financial support and BRASKEM for providing the industrial data used in this work.