



**HAL**  
open science

# Bond Graph Multi-time Scale Analysis of a Railway Traction System

Xavier Roboam, Bruno Sareni, Grace Gandanegara, Geneviève Dauphin-Tanguy

► **To cite this version:**

Xavier Roboam, Bruno Sareni, Grace Gandanegara, Geneviève Dauphin-Tanguy. Bond Graph Multi-time Scale Analysis of a Railway Traction System. 9th European Conference on Power Electronics and Applications (EPE'2001), Aug 2001, Graz, Austria. pp.0. hal-04039510

**HAL Id: hal-04039510**

**<https://hal.science/hal-04039510>**

Submitted on 21 Mar 2023

**HAL** is a multi-disciplinary open access archive for the deposit and dissemination of scientific research documents, whether they are published or not. The documents may come from teaching and research institutions in France or abroad, or from public or private research centers.

L'archive ouverte pluridisciplinaire **HAL**, est destinée au dépôt et à la diffusion de documents scientifiques de niveau recherche, publiés ou non, émanant des établissements d'enseignement et de recherche français ou étrangers, des laboratoires publics ou privés.



## Open Archive TOULOUSE Archive Ouverte (OATAO)

OATAO is an open access repository that collects the work of Toulouse researchers and makes it freely available over the web where possible.

This is an author-deposited version published in : <http://oatao.univ-toulouse.fr/>  
Eprints ID : 9266

**To cite this version** : Roboam, Xavier and Gandanegara, Grace and Sareni, Bruno and Dauphin-Tanguy, Geneviève Bond Graph Multi-time Scale Analysis of a Railway Traction System. (2001) In: 9th European Conference on Power Electronics and Applications (EPE' 2001), 27-29 August, 2001, Graz, Austria.

Any correspondence concerning this service should be sent to the repository administrator: [staff-oatao@listes-diff.inp-toulouse.fr](mailto:staff-oatao@listes-diff.inp-toulouse.fr)

# Bond Graph Multi-time Scale Analysis of a Railway Traction System

G. Gandanegara <sup>1</sup>, B. Sareni <sup>1</sup>, X. Roboam <sup>1</sup>, G. Dauphin-Tanguy <sup>2</sup>

<sup>1</sup>LEEI, UMR INPT-ENSEEIH/CNRS N° 5828  
2 Rue Camichel BP 7122, 31071 Toulouse Cedex, France  
[Xavier.Roboam@leei.enseiht.fr](mailto:Xavier.Roboam@leei.enseiht.fr)

<sup>2</sup>LAIL, Ecole Centrale de Lille, UPRESA CNRS 8021  
BP 48, 59651 Villeneuve d'Ascq Cedex, France  
[gdt@ec-lille.fr](mailto:gdt@ec-lille.fr)

## Keywords

Locomotive, induction motors, modeling, simulation.

## Abstract

The unified formalism of bond graphs is applicable to designing, modeling and analyzing complex and heterogeneous physical systems. Moreover, various order-reduction methods can be applied directly on bond graph models in order to simplify them. The aim of this paper is to demonstrate the characteristics and the advantages of the bond graph formalism, considering as an example, model simplification methods of a railway traction system. Several simulations are carried out in order to validate the simplified models. The analysis of couplings on these models highlights the elements that cause perturbations, such as mechanical resonance.

## Introduction

Railway traction systems are heterogeneous and complex systems composed of elements of various physical natures including an energy supply, power converter, electrical motor, mechanical transmission lines, mechanical load and control loop [1]. Because of this highly heterogeneous nature, bond graph models seem to be appropriate in describing and analyzing these systems. Indeed, bond graphs are a graphical tool that can represent in a unified way multi-domain systems with the use of the causality relationships [2][3][4]. Furthermore, there are simplification methods directly based on bond graphs which allow us, on the one hand, to obtain simpler models and, on the other hand, to facilitate the analysis.

In this paper we present a detailed model of a railway traction system, the BB 36000 locomotive, as our case-study. We apply 2 order reduction methods, the singular perturbation method (SPM) [5] and the model order reduction algorithm (MORA) [6][7]. Both methods are applied on the global model which is a multi-time scale model. This paper is divided in four sections. Firstly, a short review of the bond graph formalism and the modeling of the BB 36000 locomotive are described. Application of the SPM on the BB 36000 model is discussed in the next section. The third section presents briefly the MORA and its application on the same model. Finally, we discuss and compare these methods.

## Bond graph modeling of BB 36000 locomotive

### Formalism of bond graph

Bond graph formalism [2][3][4], created by H. Paynter in 1959, is a graphical method that can represent linear and non linear physical systems. It expresses energetic transfer in systems which is represented by bonds with a half-arrow that indicate the power flow between the various subsystems. This formalism can be applied to all physical domains (mechanic, electric, thermodynamic, hydraulic, magnetic,...) by using the variables associated to the generalized power-variables : effort  $e$  and flow  $f$ ,

or the generalized energy-variables : moment  $p$  (integral of effort) and displacement  $q$  (integral of flow). Each bond brings simultaneously the information of effort and flow, where the product gives the transmitted power. An example of these analogies for various fields is given in Table I. Bond graph elements can be classified in 3 categories : passive elements, active elements, and detectors. There are 3 types of passive elements; each one represents interactions between generalized variables as displayed by Paynter's tetrahedron in Fig. 1. Active elements consist of sources of effort  $Se$  and sources of flow  $Sf$ . We can use the term 'modulated' if their value is controlled. In that case, signal links symbolized with a complete arrow are used to control the modulated sources. The generalized variables can be measured by detectors of effort  $De$  and detectors of flow  $Df$ . Elements can be connected with junctions 0 (common effort), junctions 1 (common flow), transformers and gyrators. These junctions are considered as power conservatives.

**Table I : Generalized variables on several fields.**

Field	Effort $e$	Flow $f$	Moment $p$	Displacement $q$
Electrical	Voltage $u$	Current $i$	Magnetic flux $\Phi$	Charge $q$
Mechanical Translation	Force $F$	Speed $v$	Impulse $P$	Displacement $x$
Mechanical Rotation	Torque $T$	Angular Speed $\omega$	Angular impulse $h$	Angle $\theta$
Hydraulic	Pressure $P$	Flow $Q$	Pressure impulse $\Gamma$	Volume $V$

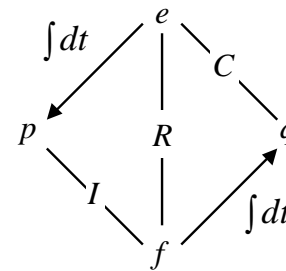

Fig. 1 : Paynter's tetrahedron.

One of the most important bond graph property is causality described on one end of a bond by a small stroke perpendicular to the bond, which represents cause-effect (causality) phenomena. Note that causality orientation does not associate to the bond orientation which is only due to the power flow orientation [2][3][4]. By following the orientation of causal strokes, the causal loops and causal paths can be determined. This permits the analysis of couplings between elements.

Bond graph formalism has several advantages. Firstly, mathematical models can be directly deduced from bond graphs, such as state equations and transfer functions [2][4]. After this, structural analysis (observability, commandability, model order, model rank,...) can be carried out immediately [2]. Moreover, direct application of model-order reduction methods on bond graph allows us to simplify the bond graph model systematically. We use this formalism to model our traction system.

### Bond graph model of the BB 36000 locomotive

The BB 36000 railway traction system [1][8], produced by Alstom Transport, is represented as block diagram in Fig. 2.

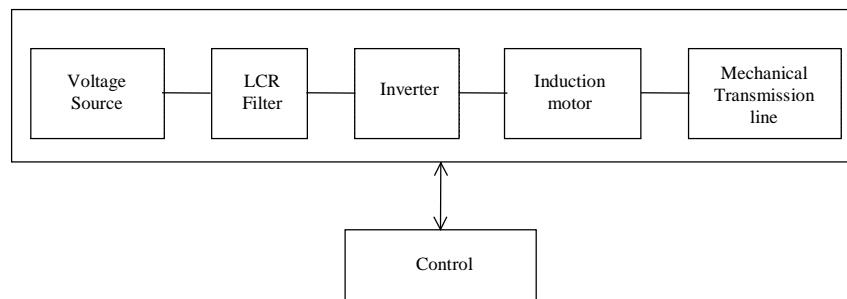

Fig. 2 : Block diagram of the BB 36000 locomotive.

#### Voltage source

We use a DC voltage source represented by an effort source  $Se$ :  $U_{cat}$  as the power supply of this system.

### LCR filter

An LCR filter is used in order to filter the current harmonics produced by the system. This filter is of order 2. The associated bond graph is presented in Fig. 3.

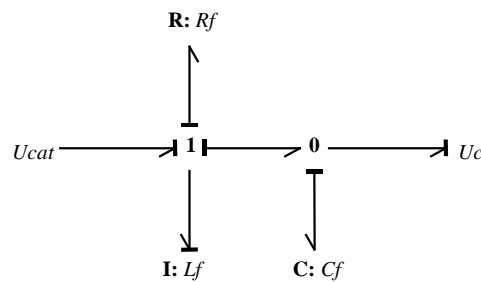

Fig. 3 : Bond graph of LCR filter.

### Inverter

To provide a three-phase alternative current, a PWM inverter is used to supply the induction motor. We model it with a modulated transformer for each phase, where the gain is given by a control signal. The PWM inverter can be modeled in two different ways : in average value and in instantaneous value [9].

### Induction motor

This locomotive drive-element is constituted of an induction motor. We model this motor as a linear Park's model represented in a fixed reference frame ( $\alpha$ - $\beta$ ). To represent couplings between rotor and stator variables, multiport elements [2] are used. The bond graph of the whole motor is displayed in Fig. 4.

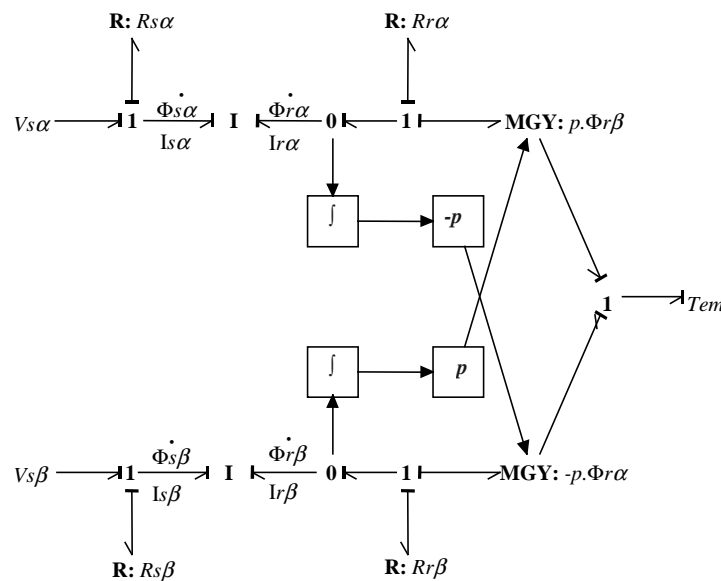

Fig. 4 : Bond graph of induction motor.

### Mechanical transmission line

The mechanical transmission line is constituted of the motor inertia followed by a first coupling element on the primary shaft. This supplies a mobile reducer which is fixed on the locomotive body through a track link. At the reducer output, another coupling element is present before the wheel inertia. A complete description of the mechanical transmission line can be found in more detail in [1][8]. There are 11 dynamic elements in this part. The model is presented in Fig. 5.

## Control

Direct Field Oriented Control of the motor is used to regulate independently the rotor flux and the electromagnetic torque. Choosing PI controllers to obtain zero-error in steady state response, this part is of order 2.

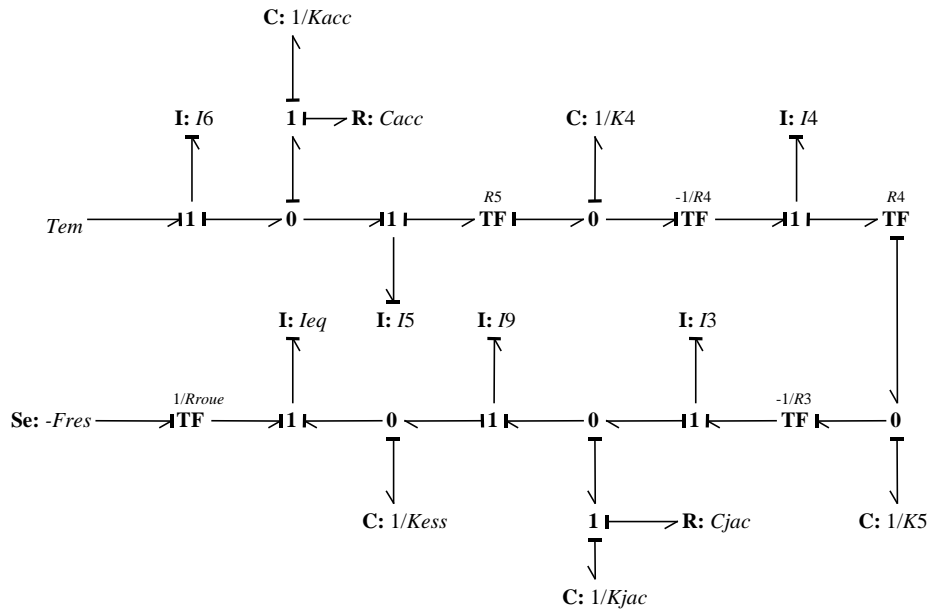

Fig. 5 : Mechanical transmission line.

The global bond graph of this system is presented in Fig. 6, and shows how this electromechanical system can be homogeneously modeled.

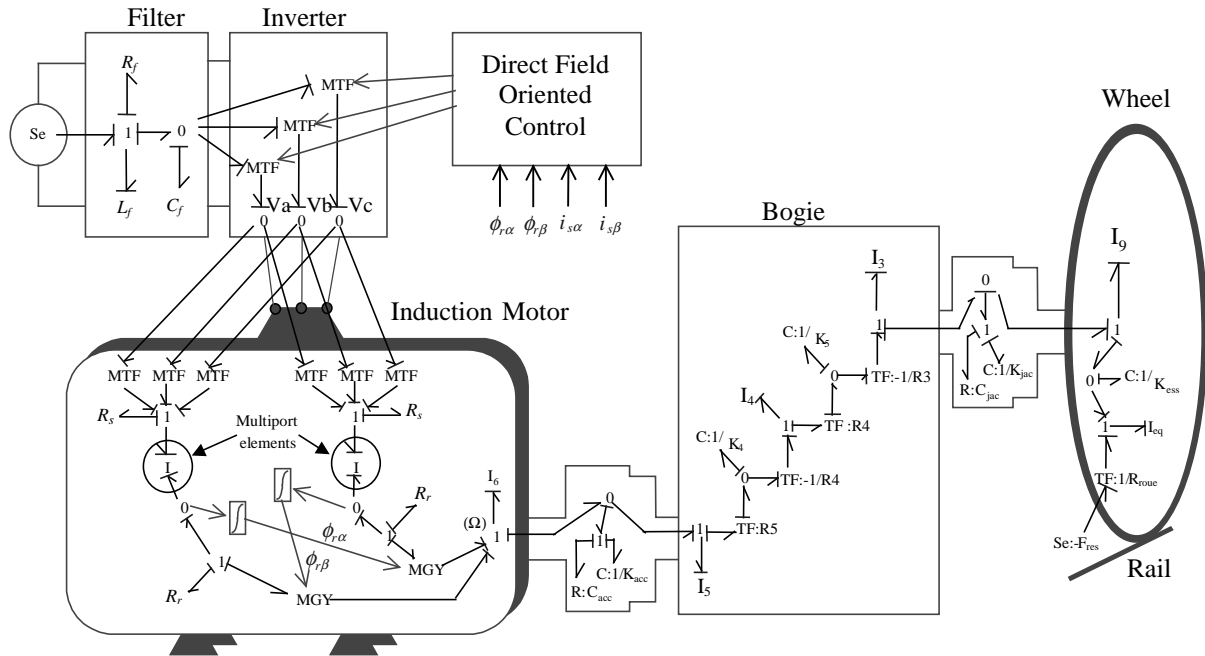

Fig. 6 : Global causal bond graph of the BB 36000 locomotive.

## Application of the singular perturbation method on the BB 36000 model

A multi-time scale system can be simplified by using the singular perturbation method. The main steps of the singular perturbation method consist of :

- determining fast and slow dynamic elements;
- separating the model into a fast and a slow model.

Two different approaches of the singular perturbation method can be used to simplify models : the classical method described in [10] employs state equations whereas the second simplification method is directly based on the bond graph representation [5]. The coherence between these approaches has been proved in [5]. For our case study, we use this last procedure i.e. the application of the singular perturbation method on the global bond graph.

In order to determine which dynamic elements are fast or slow, we examine all causal loops in the model. In fact, a causal loop reflects the coupling between two passive elements. By calculating the gain of this loop and the associated time constant (or natural period), we can estimate the corresponding dynamic. The fast elements are those which have causal loops with small time constants or high harmonic pulsation. On the other hand, the slow ones are those with the opposite characteristics. Note that to determine the dynamic of elements, we do not need any simulation.

When we apply the singular perturbation method on the BB 36000 model, we are only interested in simplifying the mechanical part since it is composed of 11 dynamic elements (more than 50% of the dynamic elements in the system), and 14 causal loops of gain varying between  $10^{-1}$  and  $10^{10}$  (see Table II). By examining all numerical values, dynamic elements can be separated into 2 different classes : 3 dynamic elements are considered to be slow (namely  $I_6$ ,  $K_{jac}$  and  $I_{eq}$ ), all others being considered as fast [9].

**Table II : Gain and time constant of causal loops in the BB 36000 traction system**

Causal loop	Coupled elements	Order of gain <sup>†</sup>	Time constant or natural period [s] <sup>†</sup>
1	R: $C_{acc} - I: I_6$	$10^{-1}$	10
2	R: $C_{acc} - I: I_5$	10	0.1
3	C: $1/K_{acc} - I: I_6$	$10^8$	$10^{-4}$
4	C: $1/K_{acc} - I: I_5$	$10^{10}$	$10^{-5}$
5	C: $1/K_4 - I: I_5$	$10^8$	$10^{-4}$
6	C: $1/K_4 - I: I_4$	$10^7$	$10^{-3}$
7	C: $1/K_5 - I: I_4$	$10^7$	$10^{-3}$
8	C: $1/K_5 - I: I_3$	$10^7$	$10^{-3}$
9	C: $1/K_{ess} - I: I_9$	$10^{10}$	$10^{-5}$
10	C: $1/K_{jac} - I: I_3$	$10^5$	$10^{-2}$
11	C: $1/K_{jac} - I: I_9$	$10^5$	$10^{-2}$
12	R: $C_{jac} - I: I_3$	1	1
13	R: $C_{jac} - I: I_9$	1	1
14	R: $1/K_{ess} - I: I_{eq}$	$10^6$	$10^{-3}$

The second step consists of dividing the global model into a fast bond graph and a slow bond graph. The procedure to obtain these models is presented in [5]. At the end of this step there are two models, each being simpler than the global model.

For our case-study, there is no source in the fast model and we can neglect its influence. Therefore, we only consider the slow model displayed in Fig. 7 as the reduced model.

Several numerical simulations have been carried out with the 20-Sim bond graph software in order to validate the simplified model of the BB 36000. We investigate various operating modes :

- a normal operating mode (system starting), the PWM controlled inverter being represented by its average values.

<sup>†</sup> Exact values are not displayed for the sake of confidentiality

- a degraded mode obtained by short-circuiting one leg of the inverter (which is consequently the same as short-circuiting the capacitor  $C_f$  of the filter).

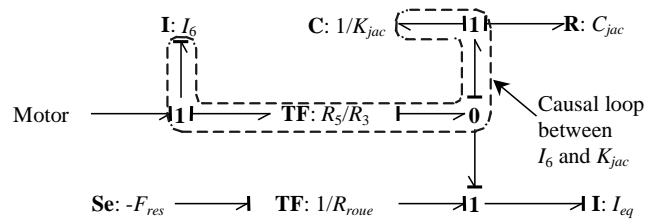

Fig. 7 : Slow bond graph of the mechanical transmission obtained with bond graph based SPM.

We present in Fig. 8 and Fig. 9 the comparison between the global and the reduced models for the electromagnetic torque and the rotor flux with PWM represented as its average value. The comparison is proposed, respectively, in the case of a normal operating mode and a degraded mode. In all cases, responses between the global and reduced models are similar. It can be noted that the short-circuit leads to a decreasing of the magnetic flux in the motor and a fast inversion of the electromagnetic torque which can result in the damage of the mechanical transmission. We also observe the effect of the train speed value to the variation of the electromagnetic torque. Simulations are presented in Fig. 10. The obtained results are in accordance with experimental values presented in [8] and show a good agreement between global and reduced models.

All investigated tests for both operating modes (i.e. normal or degraded mode) allow us to verify the validity of the model simplification by applying the singular perturbation method on the BB 36000 system.

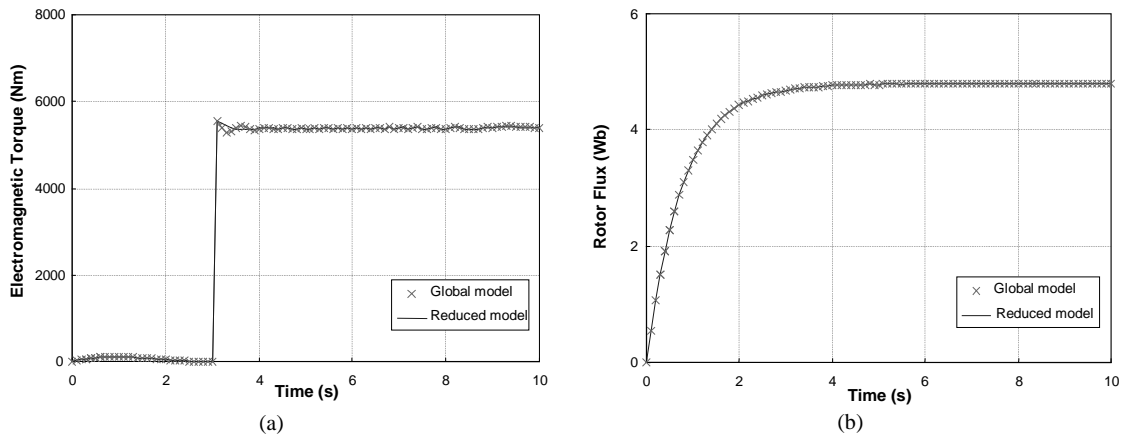

Fig. 8 : A starting transient mode.

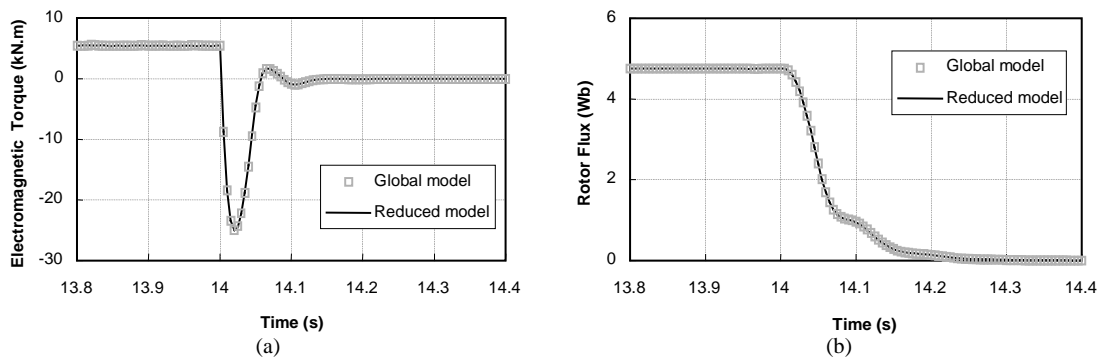

Fig. 9 : A short-circuit mode of one inverter leg.



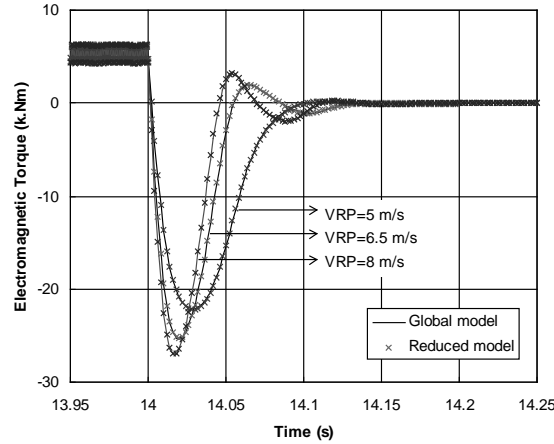

Fig. 10 : Influence of the train speed value (VRP) on the electromagnetic torque for the degraded mode.

## Model Order Reduction Algorithm

The Model Order Reduction Algorithm (MORA) is a simplification method based on energy, which can be applied to linear [6] or non linear models [7]. This method uses the concept of *activity* and *activity index* of passive elements [6][7]. Activity represents the amount of energy that flows in and out of the associated element in a time window fixed by the modeler. By calculating activity indexes, we can know which passive elements are important in the model (those with high activity indexes) and which ones are negligible (those with very low activity indexes). More information on this method can be found in [6][7]. It is of interest to apply this method to bond graphs because the energy transmitted in the bond which links each passive elements with the rest of the system can be directly calculated to estimate the elements activity.

To apply this method to non linear systems, we simulate the model according to the duration that has to be observed [7]. Then, the activity index of all passive elements is calculated and the elements are sorted from the one with the highest activity index (most important) to the one with the lowest activity index (least important). We sum the activity indexes, starting from the most important element, to obtain the cumulative activity indexes. Each element therefore has an activity index and a cumulative activity index (see Table III). The passive elements can be classified in 2 groups. The first group represents the more active elements, up to and including the first element whose the cumulative activity index is greater that the specified threshold. The specified threshold is the total activity that the modeler wants to include in the reduced model (e.g., 99.9 %) which is related to the engineering specifications of the system [7]. This group corresponds to the white part in the example of Table III. The remaining elements belong to the second group, which is displayed by the grey part in the same example.

MORA is applied on the BB 36000 global model. This model is simulated in a specified time duration in order to calculate element activity indexes. Then, we sort the elements as displayed in Table III. We choose a 99.9 % threshold and elements contributing in this threshold are written in bold. In the mechanical part of the BB 36000 locomotive, there are 3 elements which are the most important :  $I_{eq}$ ,  $I_{\delta}$  and  $K_{jac}$ . Thus, we can eliminate all other elements of the mechanical part. The reduced model of the mechanical part is presented in Fig. 11. This model is almost the same as the one obtained by the SPM, but without the damper  $R: C_{jac}$ .

**Table III : Element activity indexes of global model**

No.	Element	Activity index [%]	Cumulative activity index [%]
1	C: $C_f$	33.5142	33.5142
2	I: $I_{eq}$	13.2605	46.7746
3	I: $L_{s\beta}$	9.7925	56.5671
4	I: $L_{s\alpha}$	9.7622	66.3293
5	I: $L_{r\beta}$	9.4705	75.7998
6	I: $L_{r\alpha}$	9.4382	85.2379
7	I: $I_f$	8.1938	93.4317
8	R: $R_f$	1.3075	94.7392
9	R: $R_{s\beta}$	1.2934	96.0327
10	R: $R_{s\alpha}$	1.2439	97.2766
11	R: $R_{r\beta}$	0.9135	98.1901
12	R: $R_{r\alpha}$	0.8900	99.0800
13	I: $I_6$	0.7232	99.8033
14	C: $K_{jac}$	0.1206	99.9228
15	I: $I_3$	0.0390	99.9628
16	I: $I_4$	0.0127	99.9755
17	I: $I_9$	0.0122	99.9877
18	I: $I_5$	0.0067	99.9945
19	C: $K_4$	0.0028	99.9973
20	C: $K_5$	0.0027	100
21	C: $K_{ess}$	9.5362E-06	100
22	R: $C_{jac}$	8.1448E-06	100
23	C: $K_{acc}$	5.9841E-06	100
24	R: $C_{acc}$	2.4346E-13	100

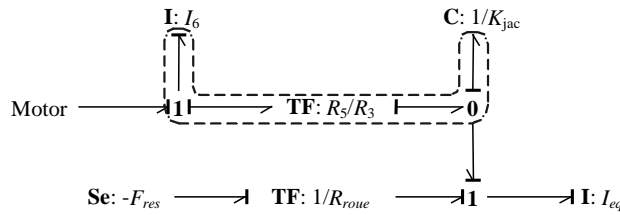

Fig. 11 : Reduced model of the mechanical part by the MORA.

## Discussion

In Fig. 12, the comparison between the responses of global and reduced models obtained by the SPM and the MORA is presented in the case of a short-circuit on an inverter leg.

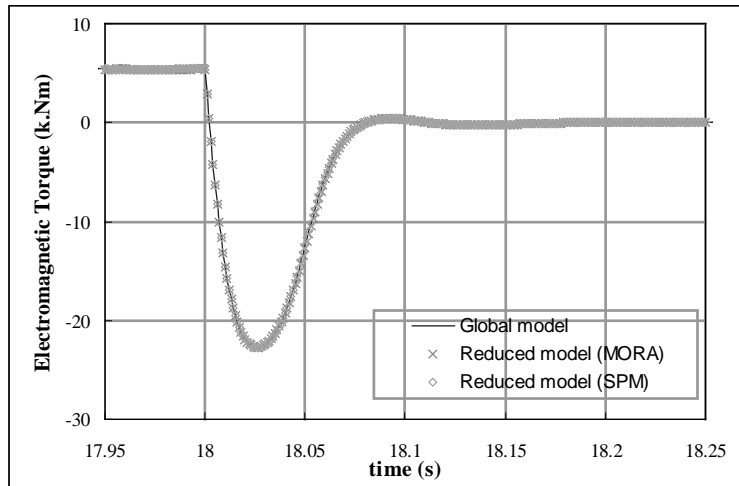

Fig. 12 : Comparison between global and reduced models obtained by the MORA and the SPM in the case of a short-circuit on one inverter leg.

The application of the order reduction methods has simplified the global model, which makes the system analysis easier. When one examines the reduced models obtained by the SPM and the MORA, it can be noted in both models that there is a causal loop between  $I: I_6$  and  $C: 1/K_{jac}$  (see Fig. 7 and Fig. 11) which has a natural pulsation corresponding to the resonance of the mechanical transmission line underlined in [8]. We stress here the strengths of these simplification methods. On the one hand, the complexity of the BB 36000 model has been reduced from 17 to 9 state variables (11 to 3 for the

mechanical part). On the other hand, the reduced bond graphs of the system explicitly emphasize the elements responsible for important perturbations, such as resonance.

Although both of these methods are appropriate to be applied on linear or non-linear models, and for our study-case they give almost the same reduced models, there are several differences between them. The SPM is very suitable to be applied on a model with disparate dynamics (multi-time scale model), but sometimes we can not determine easily which dynamics are fast (or slow) in a model if its elements have the same frame of dynamics. On the other hand, the MORA can be applied on both cases, multi-time scale or not. Another difference is in the procedure of each method. For the MORA, we have to simulate the model (or if not, we have to solve analytically complex calculation), which can be inconvenient when the cost of memory and the time computation needed in simulations are high. Contrary to the MORA, we do not need any simulation for the SPM.

## Conclusion

In this paper, we have shown the interest of using bond graphs to model and analyze complex systems such as the BB 36000 locomotive. Direct application of the singular perturbation method on bond graph permits us to accurately simplify this multi-time scale model without simulation; this is verified by using the Model Order Reduction Algorithm. Simplified models can reflect precisely the behavior of the system and make its analysis easier. The reduced models of the BB 36000 locomotive have clarified the role of the dynamic elements responsible for perturbations such as mechanical resonance. This provides interesting perspectives, notably concerning the modification of the dimensions of these elements in preliminary design stages to avoid perturbations in the system. On the other hand, order reduction of bond graph models allow us to minimize time computation of physical variables. This becomes essential for applications such as automated optimal design which requires an high number of system simulations.

## References

- [1]. C. Lochot, X. Roboam, B. de Fornel, F. Moll, *High speed railway traction system modelling for simulating electromechanical interactions*, WCRR'97, Firenze, Italia, 1997.
- [2]. G. Dauphin-Tanguy, *Les Bond Graphs*, Hermès, Paris, 2000.
- [3]. D. Karnopp, D. Margolis, R. Rosenberg, *System Dynamics: Modeling and Simulation of Mechatronic Systems*, John Wiley & son, 3<sup>rd</sup> ed., 2000.
- [4]. P. Borne, G. Dauphin-Tanguy, J.P. Richard, F. Rotella, I. Zimbettakis, *Modélisation et Identification des Processus*, Méthodes et pratiques de l'ingénieur, édition Technip, vol. 3, tome 2, 1992.
- [5]. C. Sueur and G. Dauphin-Tanguy, *Bond Graph Approach to Multi-time Scale Systems Analysis*, Journal of the Franklin Institute vol. 328, pp. 1005-1026, Pergamon press, 1991.
- [6]. L.S. Louca and J.L. Stein, *Energy-based Model Reduction of Linear Systems*, Proceedings of International Conference on Bond Graph Modeling and Simulation ICBGM'99, San Francisco, 1999.
- [7]. L.S. Louca, J.L. Stein and G.M. Hulbert, *A Physical-based Model Reduction Metric with an Application to Vehicle Dynamics*, Proceedings of 4<sup>th</sup> IFAC Nonlinear Control Systems Symposium, Enschede, The Netherlands, 1998.
- [8]. C. Lochot, *Modélisation et caractérisation des phénomènes couplés dans une chaîne de traction ferroviaire asynchrone*, Thèse INP Toulouse, 1999.
- [9]. G. Gandanegara, X. Roboam, B. Sareni, G. Dauphin-Tanguy, *Modeling and Multi-time Scale Analysis of Railway Traction Systems Using Bond Graphs*, Proceeding of International Conference on Bond Graph Modeling and Simulation ICBGM'01, Phoenix, 2001.
- [10]. P. Kokotovic, H.K. Khalil and J. O'reilly, *Singular Perturbation Methods in Control. Analysis and Design*, Academic Press, London, 1986.