



**HAL**  
open science

## Pressure-driven Steady-State Simulation of Oilfield Infrastructure

Pascal Floquet, Xavier Joulia, Alain Vacher, Martin Gainville, Michel Pons

► **To cite this version:**

Pascal Floquet, Xavier Joulia, Alain Vacher, Martin Gainville, Michel Pons. Pressure-driven Steady-State Simulation of Oilfield Infrastructure. 17th European Symposium on Computer-Aided Process Engineering ESCAPE-17, May 2007, Bucharest, Romania. pp.527-532. hal-04034410

**HAL Id: hal-04034410**

**<https://hal.science/hal-04034410>**

Submitted on 17 Mar 2023

**HAL** is a multi-disciplinary open access archive for the deposit and dissemination of scientific research documents, whether they are published or not. The documents may come from teaching and research institutions in France or abroad, or from public or private research centers.

L'archive ouverte pluridisciplinaire **HAL**, est destinée au dépôt et à la diffusion de documents scientifiques de niveau recherche, publiés ou non, émanant des établissements d'enseignement et de recherche français ou étrangers, des laboratoires publics ou privés.



Pressure-Driven  
Steady-State  
Simulation of  
Oilfield  
Infrastructure

Pascal Floquet<sup>1</sup>,  
Xavier Joulia<sup>1</sup>,  
Alain Vacher<sup>2</sup>,  
Martin  
Gainville<sup>3</sup>,  
Michel Pons<sup>4</sup>

# Pressure-Driven Steady-State Simulation of Oilfield Infrastructure

Pascal Floquet<sup>1</sup>, Xavier Joulia<sup>1</sup>, Alain Vacher<sup>2</sup>,  
Martin Gainville<sup>3</sup>, Michel Pons<sup>4</sup>

- (1) Laboratoire de Génie Chimique (LGC), Toulouse , France
- (2) ProSim, Labège, France
- (3) IFP Direction Mécanique Appliquée, Rueil-Malmaison, France
- (4) Michel Pons Technologie, Lyon, France

ESCAPE 17 - Bucharest - 27-30 May 2007





# OUTLINE

Pressure-Driven  
Steady-State  
Simulation of  
Oilfield  
Infrastructure

Pascal Floquet<sup>1</sup>,  
Xavier Joulia<sup>1</sup>,  
Alain Vacher<sup>2</sup>,  
Martin  
Gainville<sup>3</sup>,  
Michel Pons<sup>4</sup>

- Part I : Introduction and Problem Statement
- Part II : Pressure-Driven Steady-State Simulation
- Part III : Case Studies
- Part IV : CAPE-OPEN Integration
- Part V : Conclusions and Future Work



# OUTLINE

## Pressure-Driven Steady-State Simulation of Oilfield Infrastructure

Pascal Floquet<sup>1</sup>,  
Xavier Joulia<sup>1</sup>,  
Alain Vacher<sup>2</sup>,  
Martin  
Gainville<sup>3</sup>,  
Michel Pons<sup>4</sup>

- Part I : Introduction and Problem Statement
- Part II : Pressure-Driven Steady-State Simulation
- Part III : Case Studies
- Part IV : CAPE-OPEN Integration
- Part V : Conclusions and Future Work



# OUTLINE

## Pressure-Driven Steady-State Simulation of Oilfield Infrastructure

Pascal Floquet<sup>1</sup>,  
Xavier Joulia<sup>1</sup>,  
Alain Vacher<sup>2</sup>,  
Martin  
Gainville<sup>3</sup>,  
Michel Pons<sup>4</sup>

- Part I : Introduction and Problem Statement
- Part II : Pressure-Driven Steady-State Simulation
- Part III : Case Studies
- Part IV : CAPE-OPEN Integration
- Part V : Conclusions and Future Work



# OUTLINE

## Pressure-Driven Steady-State Simulation of Oilfield Infrastructure

Pascal Floquet<sup>1</sup>,  
Xavier Joulia<sup>1</sup>,  
Alain Vacher<sup>2</sup>,  
Martin  
Gainville<sup>3</sup>,  
Michel Pons<sup>4</sup>

- Part I : Introduction and Problem Statement
- Part II : Pressure-Driven Steady-State Simulation
- Part III : Case Studies
- Part IV : CAPE-OPEN Integration
- Part V : Conclusions and Future Work



# OUTLINE

Pressure-Driven  
Steady-State  
Simulation of  
Oilfield  
Infrastructure

Pascal Floquet<sup>1</sup>,  
Xavier Joulia<sup>1</sup>,  
Alain Vacher<sup>2</sup>,  
Martin  
Gainville<sup>3</sup>,  
Michel Pons<sup>4</sup>

- Part I : Introduction and Problem Statement
- Part II : Pressure-Driven Steady-State Simulation
- Part III : Case Studies
- Part IV : CAPE-OPEN Integration
- Part V : Conclusions and Future Work



Pressure-Driven  
Steady-State  
Simulation of  
Oilfield  
Infrastructure

Pascal Floquet<sup>1</sup>,  
Xavier Joulia<sup>1</sup>,  
Alain Vacher<sup>2</sup>,  
Martin  
Gainville<sup>3</sup>,  
Michel Pons<sup>4</sup>

TINA

Problem  
Statement  
Purpose  
Base Case

# Part I

## Introduction and Problem Statement





# TINA Project

Pressure-Driven  
Steady-State  
Simulation of  
Oilfield  
Infrastructure

Pascal Floquet<sup>1</sup>,  
Xavier Joulia<sup>1</sup>,  
Alain Vacher<sup>2</sup>,  
Martin  
Gainville<sup>3</sup>,  
Michel Pons<sup>4</sup>

TINA

Problem  
Statement  
Purpose  
Base Case

- **Transient Integrated Network Analysis**

- A TOTAL-IFP research collaborative project
- A platform for integrated multiphase flow simulations

• with INDISS as reference simulator

- TINA Application Domain

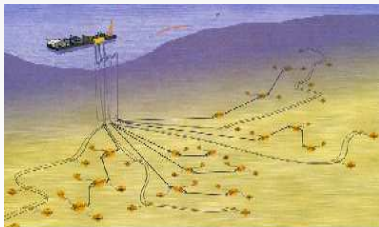



# TINA Project

Pressure-Driven  
Steady-State  
Simulation of  
Oilfield  
Infrastructure

Pascal Floquet<sup>1</sup>,  
Xavier Joulia<sup>1</sup>,  
Alain Vacher<sup>2</sup>,  
Martin  
Gainville<sup>3</sup>,  
Michel Pons<sup>4</sup>

TINA

Problem  
Statement  
Purpose  
Base Case

- Transient Integrated Network Analysis
- A TOTAL-IFP research collaborative project
- A platform for integrated multiphase flow simulations
  - From reservoir to process facilities
  - with INDISS as reference simulator
- TINA Application Domain

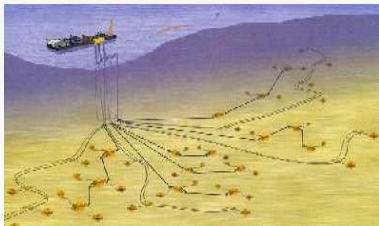



# TINA Project

Pressure-Driven  
Steady-State  
Simulation of  
Oilfield  
Infrastructure

Pascal Floquet<sup>1</sup>,  
Xavier Joulia<sup>1</sup>,  
Alain Vacher<sup>2</sup>,  
Martin  
Gainville<sup>3</sup>,  
Michel Pons<sup>4</sup>

## TINA

Problem  
Statement  
Purpose  
Base Case

- Transient Integrated Network Analysis
- A TOTAL-IFP research collaborative project
- **A platform for integrated multiphase flow simulations**
  - From reservoir to process facilities
  - For flow assurance application
  - Based on an open software architecture
  - with INDISS as reference simulator
- TINA Application Domain

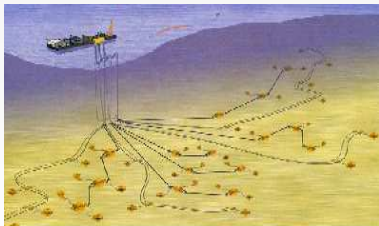



# TINA Project

Pressure-Driven  
Steady-State  
Simulation of  
Oilfield  
Infrastructure

Pascal Floquet<sup>1</sup>,  
Xavier Joulia<sup>1</sup>,  
Alain Vacher<sup>2</sup>,  
Martin  
Gainville<sup>3</sup>,  
Michel Pons<sup>4</sup>

TINA

Problem  
Statement  
Purpose  
Base Case

- Transient Integrated Network Analysis
- A TOTAL-IFP research collaborative project
- A platform for integrated multiphase flow simulations
  - From reservoir to process facilities
  - For flow assurance application
  - Based on an open software architecture
  - with INDISS as reference simulator
- TINA Application Domain

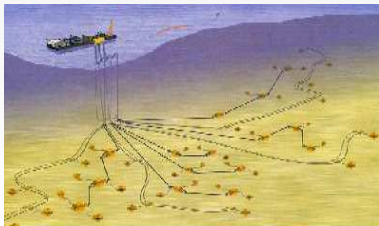



# TINA Project

Pressure-Driven  
Steady-State  
Simulation of  
Oilfield  
Infrastructure

Pascal Floquet<sup>1</sup>,  
Xavier Joulia<sup>1</sup>,  
Alain Vacher<sup>2</sup>,  
Martin  
Gainville<sup>3</sup>,  
Michel Pons<sup>4</sup>

TINA

Problem  
Statement  
Purpose  
Base Case

- Transient Integrated Network Analysis
- A TOTAL-IFP research collaborative project
- A platform for integrated multiphase flow simulations
  - From reservoir to process facilities
  - **For flow assurance application**
  - Based on an open software architecture
  - with INDISS as reference simulator
- TINA Application Domain

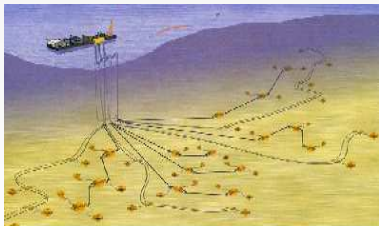



# TINA Project

Pressure-Driven  
Steady-State  
Simulation of  
Oilfield  
Infrastructure

Pascal Floquet<sup>1</sup>,  
Xavier Joulia<sup>1</sup>,  
Alain Vacher<sup>2</sup>,  
Martin  
Gainville<sup>3</sup>,  
Michel Pons<sup>4</sup>

TINA

Problem  
Statement  
Purpose  
Base Case

- Transient Integrated Network Analysis
- A TOTAL-IFP research collaborative project
- A platform for integrated multiphase flow simulations
  - From reservoir to process facilities
  - For flow assurance application
  - Based on an open software architecture
  - with INDISS as reference simulator
- TINA Application Domain

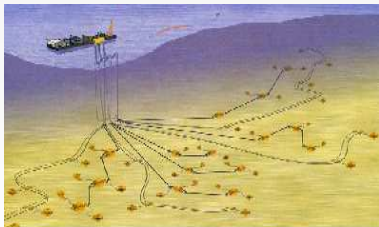



# TINA Project

Pressure-Driven  
Steady-State  
Simulation of  
Oilfield  
Infrastructure

Pascal Floquet<sup>1</sup>,  
Xavier Joulia<sup>1</sup>,  
Alain Vacher<sup>2</sup>,  
Martin  
Gainville<sup>3</sup>,  
Michel Pons<sup>4</sup>

TINA

Problem  
Statement  
Purpose  
Base Case

- Transient Integrated Network Analysis
- A TOTAL-IFP research collaborative project
- A platform for integrated multiphase flow simulations
  - From reservoir to process facilities
  - For flow assurance application
  - Based on an open software architecture
  - with **INDISS** as reference simulator
- TINA Application Domain

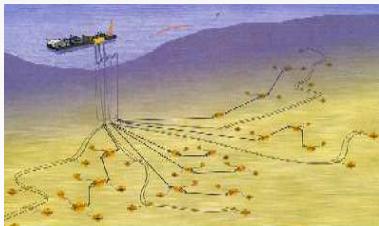



# TINA Project

Pressure-Driven  
Steady-State  
Simulation of  
Oilfield  
Infrastructure

Pascal Floquet<sup>1</sup>,  
Xavier Joulia<sup>1</sup>,  
Alain Vacher<sup>2</sup>,  
Martin  
Gainville<sup>3</sup>,  
Michel Pons<sup>4</sup>

TINA

Problem  
Statement  
Purpose  
Base Case

- Transient Integrated Network Analysis
- A TOTAL-IFP research collaborative project
- A platform for integrated multiphase flow simulations
  - From reservoir to process facilities
  - For flow assurance application
  - Based on an open software architecture
  - with INDISS as reference simulator

- **TINA Application Domain**

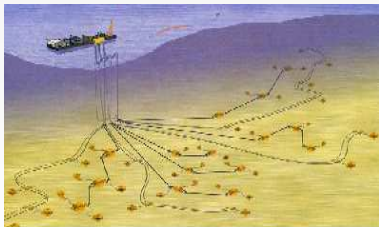





# TINA Project

Pressure-Driven  
Steady-State  
Simulation of  
Oilfield  
Infrastructure

Pascal Floquet<sup>1</sup>,  
Xavier Joulia<sup>1</sup>,  
Alain Vacher<sup>2</sup>,  
Martin  
Gainville<sup>3</sup>,  
Michel Pons<sup>4</sup>

TINA

Problem  
Statement  
Purpose  
Base Case

- Transient Integrated Network Analysis
- A TOTAL-IFP research collaborative project
- A platform for integrated multiphase flow simulations
  - From reservoir to process facilities
  - For flow assurance application
  - Based on an open software architecture
  - with INDISS as reference simulator
- TINA Application Domain

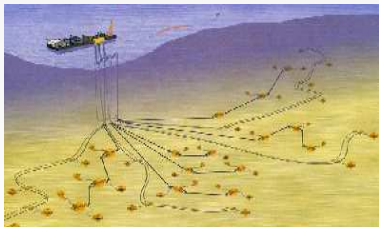



# Purpose of the study

Pressure-Driven  
Steady-State  
Simulation of  
Oilfield  
Infrastructure

Pascal Floquet<sup>1</sup>,  
Xavier Joulia<sup>1</sup>,  
Alain Vacher<sup>2</sup>,  
Martin  
Gainville<sup>3</sup>,  
Michel Pons<sup>4</sup>

TINA

Problem  
Statement

**Purpose**  
Base Case

## Extend simultaneous modular strategy

- for solving steady-state pressure-driven simulation and design problems
- in Oil and Gas production networks

## Interoperate *via* CAPE-OPEN

- Extend INDISS simulator capabilities by integration of ProSim CO SPEC module
- Extend INDISS simulator capabilities by integration of IFP TOTAL pipeline multiphase flow module



# Purpose of the study

Pressure-Driven  
Steady-State  
Simulation of  
Oilfield  
Infrastructure

Pascal Floquet<sup>1</sup>,  
Xavier Joulia<sup>1</sup>,  
Alain Vacher<sup>2</sup>,  
Martin  
Gainville<sup>3</sup>,  
Michel Pons<sup>4</sup>

TINA

Problem  
Statement

**Purpose**  
Base Case

## Extend simultaneous modular strategy

- for solving steady-state pressure-driven simulation and design problems
  - in Oil and Gas production networks

## Interoperate *via* CAPE-OPEN

- Extend INDISS simulator capabilities by integration of ProSim CO SPEC module
- Extend INDISS simulator capabilities by integration of IFP TOTAL pipeline multiphase flow module



# Purpose of the study

Pressure-Driven  
Steady-State  
Simulation of  
Oilfield  
Infrastructure

Pascal Floquet<sup>1</sup>,  
Xavier Joulia<sup>1</sup>,  
Alain Vacher<sup>2</sup>,  
Martin  
Gainville<sup>3</sup>,  
Michel Pons<sup>4</sup>

TINA

Problem  
Statement

**Purpose**  
Base Case

## Extend simultaneous modular strategy

- for solving **steady-state** pressure-driven simulation and design problems
  - in Oil and Gas production networks

## Interoperate *via* CAPE-OPEN

- Extend INDISS simulator capabilities by integration of ProSim CO SPEC module
- Extend INDISS simulator capabilities by integration of IFP TOTAL pipeline multiphase flow module



# Purpose of the study

Pressure-Driven  
Steady-State  
Simulation of  
Oilfield  
Infrastructure

Pascal Floquet<sup>1</sup>,  
Xavier Joulia<sup>1</sup>,  
Alain Vacher<sup>2</sup>,  
Martin  
Gainville<sup>3</sup>,  
Michel Pons<sup>4</sup>

TINA

Problem  
Statement

**Purpose**  
Base Case

## Extend simultaneous modular strategy

- for solving steady-state **pressure-driven** simulation and design problems
- in Oil and Gas production networks

## Interoperate *via* CAPE-OPEN

- Extend INDISS simulator capabilities by integration of ProSim CO-SPEC module
- Extend INDISS simulator capabilities by integration of IFP TOTAL pipeline multiphase flow module



# Purpose of the study

Pressure-Driven  
Steady-State  
Simulation of  
Oilfield  
Infrastructure

Pascal Floquet<sup>1</sup>,  
Xavier Joulia<sup>1</sup>,  
Alain Vacher<sup>2</sup>,  
Martin  
Gainville<sup>3</sup>,  
Michel Pons<sup>4</sup>

TINA

Problem  
Statement

**Purpose**  
Base Case

## Extend simultaneous modular strategy

- for solving steady-state **pressure-driven** simulation and design problems
- **in Oil and Gas production networks**

## Interoperate *via* CAPE-OPEN

- Extend INDISS simulator capabilities by integration of ProSim CO-SPEC module
- Extend INDISS simulator capabilities by integration of IFP TOTAL pipeline multiphase flow module



# Purpose of the study

Pressure-Driven  
Steady-State  
Simulation of  
Oilfield  
Infrastructure

Pascal Floquet<sup>1</sup>,  
Xavier Joulia<sup>1</sup>,  
Alain Vacher<sup>2</sup>,  
Martin  
Gainville<sup>3</sup>,  
Michel Pons<sup>4</sup>

TINA

Problem  
Statement  
**Purpose**  
Base Case

## Extend simultaneous modular strategy

- for solving steady-state **pressure-driven** simulation and design problems
- in Oil and Gas production networks

## Interoperate *via* CAPE-OPEN

- **Extend INDISS simulator capabilities by integration of ProSim CO-SPEC module**
- Extend INDISS simulator capabilities by integration of IFP TOTAL pipeline multiphase flow module



# Purpose of the study

Pressure-Driven  
Steady-State  
Simulation of  
Oilfield  
Infrastructure

Pascal Floquet<sup>1</sup>,  
Xavier Joulia<sup>1</sup>,  
Alain Vacher<sup>2</sup>,  
Martin  
Gainville<sup>3</sup>,  
Michel Pons<sup>4</sup>

TINA

Problem  
Statement

**Purpose**  
Base Case

## Extend simultaneous modular strategy

- for solving steady-state **pressure-driven** simulation and design problems
- in Oil and Gas production networks

## Interoperate *via* CAPE-OPEN

- Extend INDISS simulator capabilities by integration of ProSim CO-SPEC module
- **Extend INDISS simulator capabilities by integration of IFP TOTAL pipeline multiphase flow module**





# Base Case

Pressure-Driven  
Steady-State  
Simulation of  
Oilfield  
Infrastructure

Pascal Floquet<sup>1</sup>,  
Xavier Joulia<sup>1</sup>,  
Alain Vacher<sup>2</sup>,  
Martin  
Gainville<sup>3</sup>,  
Michel Pons<sup>4</sup>

TINA

Problem  
Statement  
Purpose  
Base Case

## Base case description

Two subsea production clusters,  
Two and three subsea wells  
controlled by choking wellhead valves,  
Two flowlines connected to a riser and a basic surface process

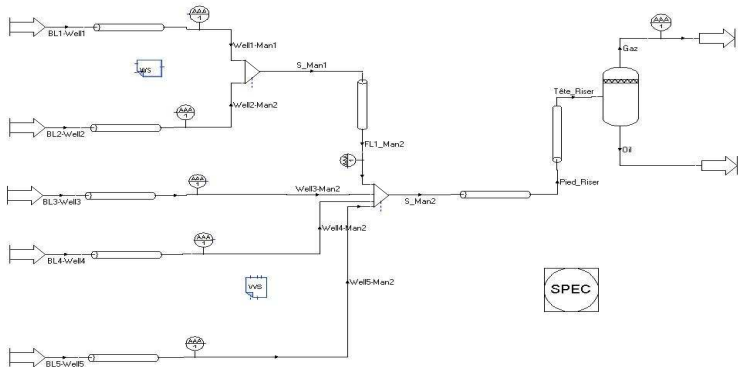



Pressure-Driven  
Steady-State  
Simulation of  
Oilfield  
Infrastructure

Pascal Floquet<sup>1</sup>,  
Xavier Joulia<sup>1</sup>,  
Alain Vacher<sup>2</sup>,  
Martin  
Gainville<sup>3</sup>,  
Michel Pons<sup>4</sup>

## Part II

# Pressure-Driven Steady-State Simulation



# Pressure-driven vs classical simulation

Pressure-Driven  
Steady-State  
Simulation of  
Oilfield  
Infrastructure

Pascal Floquet<sup>1</sup>,  
Xavier Joulia<sup>1</sup>,  
Alain Vacher<sup>2</sup>,  
Martin  
Gainville<sup>3</sup>,  
Michel Pons<sup>4</sup>

## Sequential Modular Simulation

$X^0$  : Temperature T, Pressure P, Composition z and total flowrate Q

$d$  : operating and design parameters of the modules are the standard input of a pure simulation case

## Pressure-driven Simulation

Characterize Oil and Gas upstream operations

For example, pipes connected to the same manifold must operate at the same pressure

$n_w$  Pressure Equality Constraints



# Pressure-driven vs classical simulation

Pressure-Driven  
Steady-State  
Simulation of  
Oilfield  
Infrastructure

Pascal Floquet<sup>1</sup>,  
Xavier Joulia<sup>1</sup>,  
Alain Vacher<sup>2</sup>,  
Martin  
Gainville<sup>3</sup>,  
Michel Pons<sup>4</sup>

## Sequential Modular Simulation

$X^0$  : Temperature  $T$ , Pressure  $P$ , Composition  $z$  and total flowrate  $Q$

$d$  : operating and design parameters of the modules are the standard input of a pure simulation case

## Pressure-driven Simulation

Characterize Oil and Gas upstream operations

For example, pipes connected to the same manifold must operate at the same pressure

$n_w$  Pressure Equality Constraints



# Numerical strategy in Pressure-driven simulation

Pressure-Driven  
Steady-State  
Simulation of  
Oilfield  
Infrastructure

Pascal Floquet<sup>1</sup>,  
Xavier Joulia<sup>1</sup>,  
Alain Vacher<sup>2</sup>,  
Martin  
Gainville<sup>3</sup>,  
Michel Pons<sup>4</sup>

Pressure-driven problem is a particular case of design problem

Variables associated to pressure constraints are

- the well flowrates
- other variables

Two types of problem are treated :

- **Flowrates/Pressure problems**
  - Well flowrates and riser top pressure are known
  - Action variables are chokes openings or well pressures
- **Pressures/Pressure problems**
  - Well pressures and riser top pressure are known
  - Action variables are well flowrates



# Numerical strategy in Pressure-driven simulation

Pressure-Driven  
Steady-State  
Simulation of  
Oilfield  
Infrastructure

Pascal Floquet<sup>1</sup>,  
Xavier Joulia<sup>1</sup>,  
Alain Vacher<sup>2</sup>,  
Martin  
Gainville<sup>3</sup>,  
Michel Pons<sup>4</sup>

Pressure-driven problem is a particular case of design problem  
Variables associated to pressure constraints are

- the well flowrates
- other variables

Two types of problem are treated :

- **Flowrates/Pressure problems**
  - Well flowrates and riser top pressure are known
  - Action variables are chokes openings or well pressures
- **Pressures/Pressure problems**
  - Well pressures and riser top pressure are known
  - Action variables are well flowrates



# Numerical strategy in Pressure-driven simulation

Pressure-Driven  
Steady-State  
Simulation of  
Oilfield  
Infrastructure

Pascal Floquet<sup>1</sup>,  
Xavier Joulia<sup>1</sup>,  
Alain Vacher<sup>2</sup>,  
Martin  
Gainville<sup>3</sup>,  
Michel Pons<sup>4</sup>

Pressure-driven problem is a particular case of design problem  
Variables associated to pressure constraints are

- the well flowrates
- other variables

Two types of problem are treated :

- Flowrates/Pressure problems
  - Well flowrates and riser top pressure are known
  - Action variables are chokes openings or well pressures
- Pressures/Pressure problems
  - Well pressures and riser top pressure are known
  - Action variables are well flowrates



# Numerical strategy in Pressure-driven simulation

Pressure-Driven  
Steady-State  
Simulation of  
Oilfield  
Infrastructure

Pascal Floquet<sup>1</sup>,  
Xavier Joulia<sup>1</sup>,  
Alain Vacher<sup>2</sup>,  
Martin  
Gainville<sup>3</sup>,  
Michel Pons<sup>4</sup>

Pressure-driven problem is a particular case of design problem  
Variables associated to pressure constraints are

- the well flowrates
- **other variables**

Two types of problem are treated :

- **Flowrates/Pressure problems**
  - Well flowrates and riser top pressure are known
  - Action variables are chokes openings or well pressures
- **Pressures/Pressure problems**
  - Well pressures and riser top pressure are known
  - Action variables are well flowrates





# Numerical strategy in Pressure-driven simulation

Pressure-Driven  
Steady-State  
Simulation of  
Oilfield  
Infrastructure

Pascal Floquet<sup>1</sup>,  
Xavier Joulia<sup>1</sup>,  
Alain Vacher<sup>2</sup>,  
Martin  
Gainville<sup>3</sup>,  
Michel Pons<sup>4</sup>

Pressure-driven problem is a particular case of design problem  
Variables associated to pressure constraints are

- the well flowrates
- other variables

Two types of problem are treated :

- **Flowrates/Pressure problems**
  - Well flowrates and riser top pressure are known
  - Action variables are chokes openings or well pressures
- **Pressures/Pressure problems**
  - Well pressures and riser top pressure are known
  - Action variables are well flowrates



# Numerical strategy in Pressure-driven simulation

Pressure-Driven  
Steady-State  
Simulation of  
Oilfield  
Infrastructure

Pascal Floquet<sup>1</sup>,  
Xavier Joulia<sup>1</sup>,  
Alain Vacher<sup>2</sup>,  
Martin  
Gainville<sup>3</sup>,  
Michel Pons<sup>4</sup>

Pressure-driven problem is a particular case of design problem  
Variables associated to pressure constraints are

- the well flowrates
- other variables

Two types of problem are treated :

- **Flowrates/Pressure problems**
  - Well flowrates and riser top pressure are known
  - Action variables are chokes openings or well pressures
- **Pressures/Pressure problems**
  - Well pressures and riser top pressure are known
  - Action variables are well flowrates



# Numerical strategy in Pressure-driven simulation

Pressure-Driven  
Steady-State  
Simulation of  
Oilfield  
Infrastructure

Pascal Floquet<sup>1</sup>,  
Xavier Joulia<sup>1</sup>,  
Alain Vacher<sup>2</sup>,  
Martin  
Gainville<sup>3</sup>,  
Michel Pons<sup>4</sup>

Pressure-driven problem is a particular case of design problem  
Variables associated to pressure constraints are

- the well flowrates
- other variables

Two types of problem are treated :

- **Flowrates/Pressure problems**
  - Well flowrates and riser top pressure are known
  - Action variables are chokes openings or well pressures
- **Pressures/Pressure problems**
  - Well pressures and riser top pressure are known
  - Action variables are well flowrates



# Numerical strategy in Pressure-driven simulation

Pressure-Driven  
Steady-State  
Simulation of  
Oilfield  
Infrastructure

Pascal Floquet<sup>1</sup>,  
Xavier Joulia<sup>1</sup>,  
Alain Vacher<sup>2</sup>,  
Martin  
Gainville<sup>3</sup>,  
Michel Pons<sup>4</sup>

Pressure-driven problem is a particular case of design problem  
Variables associated to pressure constraints are

- the well flowrates
- other variables

Two types of problem are treated :

- **Flowrates/Pressure problems**
  - Well flowrates and riser top pressure are known
  - **Action variables are chokes openings or well pressures**
- **Pressures/Pressure problems**
  - Well pressures and riser top pressure are known
  - Action variables are well flowrates



# Numerical strategy in Pressure-driven simulation

Pressure-Driven  
Steady-State  
Simulation of  
Oilfield  
Infrastructure

Pascal Floquet<sup>1</sup>,  
Xavier Joulia<sup>1</sup>,  
Alain Vacher<sup>2</sup>,  
Martin  
Gainville<sup>3</sup>,  
Michel Pons<sup>4</sup>

Pressure-driven problem is a particular case of design problem  
Variables associated to pressure constraints are

- the well flowrates
- other variables

Two types of problem are treated :

- **Flowrates/Pressure problems**
  - Well flowrates and riser top pressure are known
  - Action variables are chokes openings or well pressures
- **Pressures/Pressure problems**
  - Well pressures and riser top pressure are known
  - Action variables are well flowrates



# Numerical strategy in Pressure-driven simulation

Pressure-Driven  
Steady-State  
Simulation of  
Oilfield  
Infrastructure

Pascal Floquet<sup>1</sup>,  
Xavier Joulia<sup>1</sup>,  
Alain Vacher<sup>2</sup>,  
Martin  
Gainville<sup>3</sup>,  
Michel Pons<sup>4</sup>

Pressure-driven problem is a particular case of design problem  
Variables associated to pressure constraints are

- the well flowrates
- other variables

Two types of problem are treated :

- **Flowrates/Pressure problems**
  - Well flowrates and riser top pressure are known
  - Action variables are chokes openings or well pressures
- **Pressures/Pressure problems**
  - Well pressures and riser top pressure are known
  - Action variables are well flowrates



# Numerical strategy in Pressure-driven simulation

Pressure-Driven  
Steady-State  
Simulation of  
Oilfield  
Infrastructure

Pascal Floquet<sup>1</sup>,  
Xavier Joulia<sup>1</sup>,  
Alain Vacher<sup>2</sup>,  
Martin  
Gainville<sup>3</sup>,  
Michel Pons<sup>4</sup>

Pressure-driven problem is a particular case of design problem  
Variables associated to pressure constraints are

- the well flowrates
- other variables

Two types of problem are treated :

- **Flowrates/Pressure problems**
  - Well flowrates and riser top pressure are known
  - Action variables are chokes openings or well pressures
- **Pressures/Pressure problems**
  - Well pressures and riser top pressure are known
  - **Action variables are well flowrates**



Pressure-Driven  
Steady-State  
Simulation of  
Oilfield  
Infrastructure

Pascal Floquet<sup>1</sup>,  
Xavier Joulia<sup>1</sup>,  
Alain Vacher<sup>2</sup>,  
Martin  
Gainville<sup>3</sup>,  
Michel Pons<sup>4</sup>

Without recycle

With recycle

## Part III

### Case Studies





# Flowsheet without recycle

Pressure-Driven  
Steady-State  
Simulation of  
Oilfield  
Infrastructure

Pascal Floquet<sup>1</sup>,  
Xavier Joulia<sup>1</sup>,  
Alain Vacher<sup>2</sup>,  
Martin  
Gainville<sup>3</sup>,  
Michel Pons<sup>4</sup>

Without recycle

With recycle

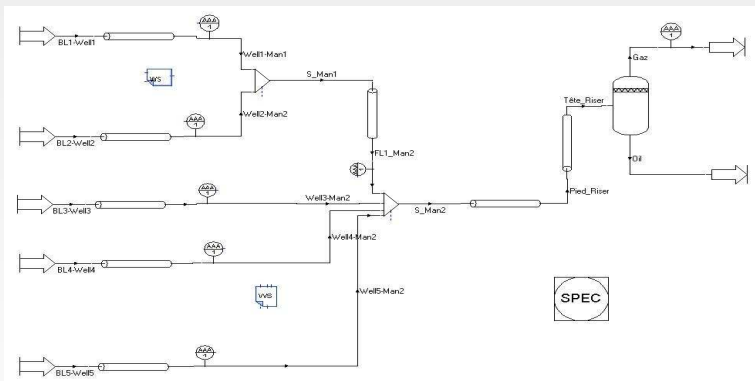

We are interested to examine the ability of convergence of Sequential Modular Simulator in Pressure Driven Problem



# Flowrates/Pressure problem

Pressure-Driven  
Steady-State  
Simulation of  
Oilfield  
Infrastructure

Pascal Floquet<sup>1</sup>,  
Xavier Joulia<sup>1</sup>,  
Alain Vacher<sup>2</sup>,  
Martin  
Gainville<sup>3</sup>,  
Michel Pons<sup>4</sup>

Without recycle

With recycle

## FP Problem :

- Specification on the pressure at riser top
- Well pressures, flowrates and temperature are fixed (base case)
- Action variables : 5 pressure drops of the 5 chokes
- *Quasi-Newton* Strategy used
- Results obtained in 4 iterations and 11 flowsheet simulations, for 15 bar

## 5 Pressure Drops *versus* Riser top pressure specification

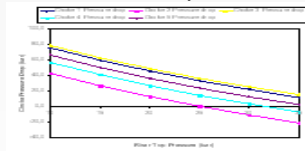



# Flowrates/Pressure problem

Pressure-Driven  
Steady-State  
Simulation of  
Oilfield  
Infrastructure

Pascal Floquet<sup>1</sup>,  
Xavier Joulia<sup>1</sup>,  
Alain Vacher<sup>2</sup>,  
Martin  
Gainville<sup>3</sup>,  
Michel Pons<sup>4</sup>

Without recycle

With recycle

## FP Problem :

- Specification on the pressure at riser top
- Well pressures, flowrates and temperature are fixed (base case)
- Action variables : 5 pressure drops of the 5 chokes
- *Quasi-Newton* Strategy used
- Results obtained in 4 iterations and 11 flowsheet simulations, for 15 bar

## 5 Pressure Drops *versus* Riser top pressure specification

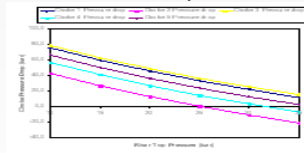



# Pressures/Pressure problem

Pressure-Driven  
Steady-State  
Simulation of  
Oilfield  
Infrastructure

Pascal Floquet<sup>1</sup>,  
Xavier Joulia<sup>1</sup>,  
Alain Vacher<sup>2</sup>,  
Martin  
Gainville<sup>3</sup>,  
Michel Pons<sup>4</sup>

Without recycle

With recycle

## PP Problem :

- Specification on the pressure at riser top
- Pressures drops of the 5 chokes, well pressures and temperature are fixed
- Action variables : 5 well flowrates
- Results obtained in 5 iterations and 12 flowsheet simulations, for 15 bar
- ...but it depends on initialization !

## 5 Flowrates *versus* Riser top pressure specification

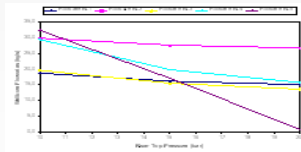



# Pressures/Pressure problem

Pressure-Driven  
Steady-State  
Simulation of  
Oilfield  
Infrastructure

Pascal Floquet<sup>1</sup>,  
Xavier Joulia<sup>1</sup>,  
Alain Vacher<sup>2</sup>,  
Martin  
Gainville<sup>3</sup>,  
Michel Pons<sup>4</sup>

Without recycle

With recycle

## PP Problem :

- Specification on the pressure at riser top
- Pressures drops of the 5 chokes, well pressures and temperature are fixed
- Action variables : 5 well flowrates
- Results obtained in 5 iterations and 12 flowsheet simulations, for 15 bar
- ...but it depends on initialization !

## 5 Flowrates *versus* Riser top pressure specification

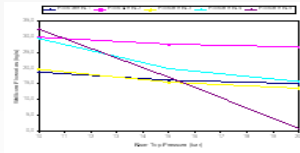



# FP or PP Problem with recycle

Pressure-Driven  
Steady-State  
Simulation of  
Oilfield  
Infrastructure

Pascal Floquet<sup>1</sup>,  
Xavier Joulia<sup>1</sup>,  
Alain Vacher<sup>2</sup>,  
Martin  
Gainville<sup>3</sup>,  
Michel Pons<sup>4</sup>

Without recycle

With recycle

Here gas-lift may be mandatory.

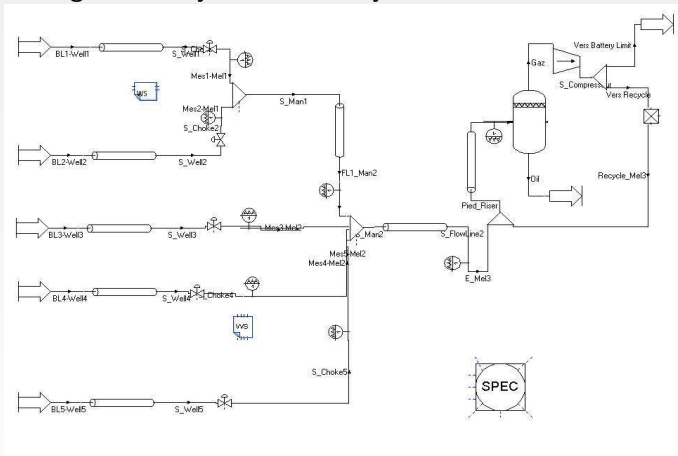



# Flowrates/Pressure Problem

Pressure-Driven  
Steady-State  
Simulation of  
Oilfield  
Infrastructure

Pascal Floquet<sup>1</sup>,  
Xavier Joulia<sup>1</sup>,  
Alain Vacher<sup>2</sup>,  
Martin  
Gainville<sup>3</sup>,  
Michel Pons<sup>4</sup>

Without recycle

With recycle

- Specification on the pressure at riser top
- Action variables : pressure drops of 4 chokes and flowrate of gas-lift
- Tear stream : compressor output ( $15 + 2(T, P)$  iterative variables)
- Less eruptive choke completely open
- Results obtained in 5 iterations and 12 flowsheet simulations, for 30 bar

Recycle rate *versus* Riser top pressure specification

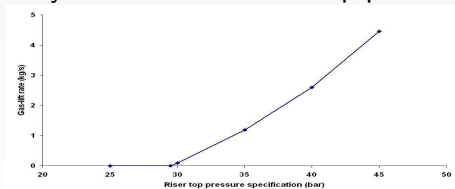



# Flowrates/Pressure Problem

Pressure-Driven  
Steady-State  
Simulation of  
Oilfield  
Infrastructure

Pascal Floquet<sup>1</sup>,  
Xavier Joulia<sup>1</sup>,  
Alain Vacher<sup>2</sup>,  
Martin  
Gainville<sup>3</sup>,  
Michel Pons<sup>4</sup>

Without recycle

With recycle

- Specification on the pressure at riser top
- Action variables : pressure drops of 4 chokes and flowrate of gas-lift
- Tear stream : compressor output (15 + 2 (T, P) iterative variables)
- Less eruptive choke completely open
- Results obtained in 5 iterations and 12 flowsheet simulations, for 30 bar

Recycle rate *versus* Riser top pressure specification

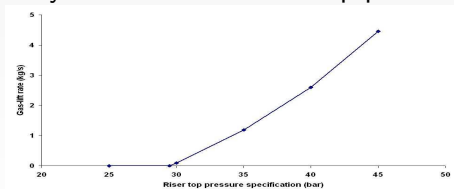





Pressure-Driven  
Steady-State  
Simulation of  
Oilfield  
Infrastructure

Pascal Floquet<sup>1</sup>,  
Xavier Joulia<sup>1</sup>,  
Alain Vacher<sup>2</sup>,  
Martin  
Gainville<sup>3</sup>,  
Michel Pons<sup>4</sup>

CO Results

## Part IV

# CAPE-OPEN Integration



# Interoperability

Pressure-Driven  
Steady-State  
Simulation of  
Oilfield  
Infrastructure

Pascal Floquet<sup>1</sup>,  
Xavier Joulia<sup>1</sup>,  
Alain Vacher<sup>2</sup>,  
Martin  
Gainville<sup>3</sup>,  
Michel Pons<sup>4</sup>

CO Results

- ProSimPlus is reference simulator chosen to adjust the approach
- IFP TOTAL pipeline multiphase flow modules are specialized upstream Oil and Gas modules
- ProSim CO-SPEC (CAPE-OPEN Unit Operation 1.0)
- and IFP TOTAL pipeline multiphase flow modules

integrated in INDISS-TINA environment



# Interoperability

Pressure-Driven  
Steady-State  
Simulation of  
Oilfield  
Infrastructure

Pascal Floquet<sup>1</sup>,  
Xavier Joulia<sup>1</sup>,  
Alain Vacher<sup>2</sup>,  
Martin  
Gainville<sup>3</sup>,  
Michel Pons<sup>4</sup>

CO Results

- ProSimPlus is reference simulator chosen to adjust the approach
  - IFP TOTAL pipeline multiphase flow modules are specialized upstream Oil and Gas modules
  - ProSim CO-SPEC (CAPE-OPEN Unit Operation 1.0)
  - and IFP TOTAL pipeline multiphase flow modules
- integrated in INDISS-TINA environment



# Interoperability

Pressure-Driven  
Steady-State  
Simulation of  
Oilfield  
Infrastructure

Pascal Floquet<sup>1</sup>,  
Xavier Joulia<sup>1</sup>,  
Alain Vacher<sup>2</sup>,  
Martin  
Gainville<sup>3</sup>,  
Michel Pons<sup>4</sup>

CO Results

- ProSimPlus is reference simulator chosen to adjust the approach
  - IFP TOTAL pipeline multiphase flow modules are specialized upstream Oil and Gas modules
  - ProSim CO-SPEC (CAPE-OPEN Unit Operation 1.0)
    - and IFP TOTAL pipeline multiphase flow modules
- integrated in INDISS-TINA environment



# Interoperability

Pressure-Driven  
Steady-State  
Simulation of  
Oilfield  
Infrastructure

Pascal Floquet<sup>1</sup>,  
Xavier Joulia<sup>1</sup>,  
Alain Vacher<sup>2</sup>,  
Martin  
Gainville<sup>3</sup>,  
Michel Pons<sup>4</sup>

CO Results

- ProSimPlus is reference simulator chosen to adjust the approach
  - IFP TOTAL pipeline multiphase flow modules are specialized upstream Oil and Gas modules
  - ProSim CO-SPEC (CAPE-OPEN Unit Operation 1.0)
  - **and IFP TOTAL pipeline multiphase flow modules**
- integrated in INDISS-TINA environment



Pressure-Driven  
Steady-State  
Simulation of  
Oilfield  
Infrastructure

Pascal Floquet<sup>1</sup>,  
Xavier Joulia<sup>1</sup>,  
Alain Vacher<sup>2</sup>,  
Martin  
Gainville<sup>3</sup>,  
Michel Pons<sup>4</sup>

## Part V

### Conclusion and future work



To conclude...

Pressure-Driven  
Steady-State  
Simulation of  
Oilfield  
Infrastructure

Pascal Floquet<sup>1</sup>,  
Xavier Joulia<sup>1</sup>,  
Alain Vacher<sup>2</sup>,  
Martin  
Gainville<sup>3</sup>,  
Michel Pons<sup>4</sup>

CAPE tools such as ProSimPlus are able to solve  
pressure-driven simulation  
CAPE-OPEN standards are the best way to plug-and-play  
CAPE software components

## Future Works

Multi period optimization in an Oil and Gas context



# To conclude...

Pressure-Driven  
Steady-State  
Simulation of  
Oilfield  
Infrastructure

Pascal Floquet<sup>1</sup>,  
Xavier Joulia<sup>1</sup>,  
Alain Vacher<sup>2</sup>,  
Martin  
Gainville<sup>3</sup>,  
Michel Pons<sup>4</sup>

CAPE tools such as ProSimPlus are able to solve pressure-driven simulation  
CAPE-OPEN standards are the best way to plug-and-play CAPE software components

## Future Works

Multi period optimization in an Oil and Gas context





Pressure-Driven  
Steady-State  
Simulation of  
Oilfield  
Infrastructure

Pascal Floquet<sup>1</sup>,  
Xavier Joulia<sup>1</sup>,  
Alain Vacher<sup>2</sup>,  
Martin  
Gainville<sup>3</sup>,  
Michel Pons<sup>4</sup>

*THANK YOU FOR YOUR ATTENTION!*