

## Pressure-driven Steady-State Simulation of Oilfield Infrastructure

Pascal Floquet<sup>(a)♦</sup>, Xavier Joulia<sup>(a)</sup>, Alain Vacher<sup>(b)</sup>, Martin Gainville<sup>(c)</sup>, Michel Pons<sup>(d)</sup>

<sup>a</sup>*Laboratoire de Génie Chimique (LGC), UMR-CNRS 5503, INPT-ENSIACET, 118, route de Narbonne, 31077 Toulouse Cedex 4 France. [Pascal.Floquet@ensiacet.fr](mailto:Pascal.Floquet@ensiacet.fr), [Xavier.Joulia@ensiacet.fr](mailto:Xavier.Joulia@ensiacet.fr)*

<sup>b</sup>*ProSim, Stratège Bâtiment A, BP 2738, F-31312 Labège Cedex France. [Alain.Vacher@prosim.net](mailto:Alain.Vacher@prosim.net)*

<sup>c</sup>*IFP Direction Mécanique Appliquée, IFP-Rueil, 1-4 avenue de Bois Préau, 92852 Rueil-Malmaison Cedex France. [Martin.GAINVILLE@ifp.fr](mailto:Martin.GAINVILLE@ifp.fr)*

<sup>d</sup>*Michel Pons Technologie, 32, rue Raulin, F-69007 Lyon, France. [michelpons.mpt@tiscali.fr](mailto:michelpons.mpt@tiscali.fr)*

### Abstract

Within the *TINA* research Project (Transient Integrated Network Analysis) and in partnership with Total, IFP is developing a new generation of simulation tool for flow assurance studies. This integrated simulation software will be able to perform multiphase simulations from the wellbore to the surface facilities. Steady-state simulation tools are used at the early stages of a study for conceptual design, detailed engineering and for initializing dynamic simulations. Dynamic simulation tools are used for evaluating and better understanding the transient behaviour of an oil and gas production network. The purpose of this paper is to define, in a CAPE-OPEN compliant environment, a strategy to solve pressure-driven steady-state simulation problems, i.e. pure simulation and design problems, in the specific context of hydrocarbon production and transport from the wellbore to the surface facilities.

**Keywords :** Pressure-driven simulation, Oilfield, CAPE-OPEN

### 1. Introduction

Usually, a deep water production system is constituted by a main field with links to satellite fields. The infrastructure of the system is made of subsea wellhead clusters, chokes, manifolds, production lines, risers and surface process units for separating liquid (water, oil) and gas phases (figure 1).

---

♦ Author to whom correspondence should be addressed [Pascal.Floquet@ensiacet.fr](mailto:Pascal.Floquet@ensiacet.fr)

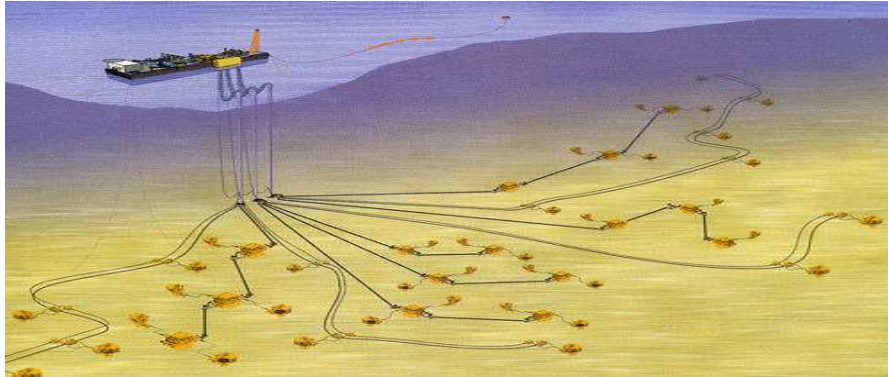

Figure 1.: Deep Water Production System

The first part of this paper presents, using a simultaneous modular strategy, how to formulate and solve pressure-driven simulation problems. In a pressure-driven process model, flowrates are such as pressure equality is satisfied at each manifold and mixing point of the flowsheet. By using the steady-state process simulator ProSimPlus™, simulation and design problems are solved in two representative cases: without material stream recycle and with recycle of compressed gas to the riser inlet (gas-lift). These two basic cases are modelling different operating periods of an oil and gas production system; the first case corresponds to the beginning of a field operation, the second one to the case of the activation of “non-eruptive” wells with riser top pressure constraint.

In a second part of this paper, CAPE tools interoperability is demonstrated through an industrial application: the ProSimPlus™ SPEC module (design specifications and recycle streams solver) on the one hand and the IFP multiphase pipe module on the other hand are used as CAPE-OPEN compliant Unit Operations and integrated in the INDISS-TINA dynamic simulation tool.

## 2. Problem Statement

The first purpose of this study is to extend simultaneous modular strategy [1], *via* ProSimPlus™ simulator and IFP process data, for solving steady-state pressure-driven simulation and design problems of oil and gas production networks. To perform this step, we have defined the following base case study.

The flowsheet (figure 2) includes two subsea production clusters constituted by respectively two (BL1-2) and three (BL3-5) subsea wells. Well flows are controlled by choking wellhead valves. Clusters are connected together by a subsea flow line and a second flow line, connected to a riser, transports the production up to surface facilities. Finally, a basic surface process (flash drum) is used to separate oil and gas phases, as shown in figure 2. Gas is compressed and a part can be recycled to the riser bottom for gas-lift operation.

Each wellbore is known in terms of temperature, pressure, composition, gas-oil ratio and watercut. From this base case, it is possible to define two main studies: flowsheet without recycle (figure 2) and with recycle of gas from the riser top (gas-lift). For each study several simulation and design problems are considered.

## Pressure-driven Steady-State Simulation of Oilfield Infrastructure

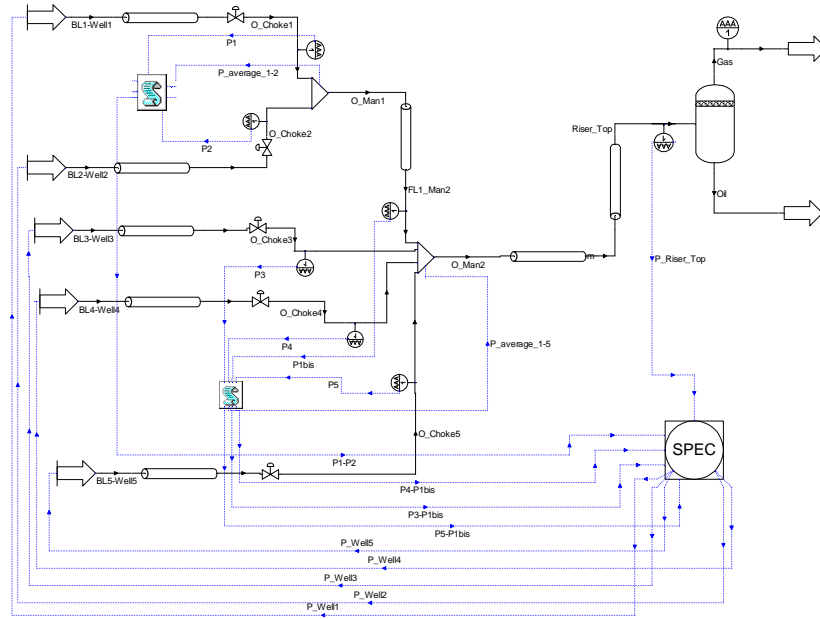

Figure 2. : Base Case Flowsheet

### 3. Pressure-driven Steady-State Simulation

In a sequential modular simulator, such as ProSimPlus™, the set of variables defining the process feeds  $\mathbf{X}^\circ$  (temperature  $T$ , pressure  $P$ , composition  $\mathbf{z}$  and total flowrate) and the operating and design parameters  $\mathbf{P}$  of the modules constitutes the standard input data of a pure simulation problem. In case of pressure-driven simulation problem, only the intensive variables ( $T$ ,  $P$  and  $\mathbf{z}$ ), which define the reservoir states at the wellbore bottoms, belong to the input data; well flowrates must be calculated in order to satisfy the constraints: “all wells connected to the same manifold must operate at the same pressure”. Thus, each node of the hydraulic network adds  $(n_{ce}-1)$  equality constraints, where  $n_{ce}$  is the number of input streams of the node. These pressure constraints are the following:

$$(P_{n,i} - P_{n,j})/P^\phi = 0 \quad j > i \quad i=1,2,\dots,(n_{ce}-1); j=2,\dots,n_{ce}; n=1,2,\dots,n_e$$

where  $n_e$  is the total number of the network nodes and  $P^\phi$  a reference pressure. The total number of pressure equality constraints is equal to  $(n_w-1)$ , where  $n_w$  is the total number of wells. From a numerical strategy point of view, a pressure-driven problem can be seen as a particular case of a design problem: some degrees of freedom are saturated by design specification equations, instead of standard data set, and an equivalent number of variables belonging to  $\mathbf{X}^\circ$  or  $\mathbf{P}$  is transferred from the input data set to the set of unknowns. The physical variables associated to pressure constraints are the well flowrates but other variables can be chosen to satisfy pressure equalities, depending on the design

problem. For each basic case, without and with gas-lift (recycle), two types of problems are defined:

- flowrates/pressure type in which well **flowrates** and riser top **pressure** are fixed and action variables, chosen among chokes (valves) openings or well pressures, are adjusted to verify pressure equality at each manifold as well as the riser top pressure constraint.
- Pressures/pressure type in which well **pressures** and riser top **pressure** are fixed and only the well flowrates are action variables, for the same set of constraints.

In ProSimPlus™, design problems are solved according to the simultaneous modular approach. Process level equations, corresponding to design specifications and recycle streams are simultaneously solved by a general non-linear algebraic equations solver, the SPEC module. As shown on figure 2, information streams are used by SPEC for acting on module parameters and for transferring residues on design specification equations (pressure constraints from the manifolds and specification on the riser top pressure) back to SPEC.

#### 4. Case studies

For each case studied (with or without recycle) the constraints of pressure equilibrium at each manifold are imposed and the riser top pressure is specified.

##### 4.1. Case Studies without recycle

For the first flowrates/pressure problem, action variables are defined as the pressure drops of the five chokes. Convergence is obtained in 4 iterations and only 11 flowsheet simulations using the *Broyden-Identity* (BRI) method [2-3] for a specification of 15 bar for the pressure at riser top. Figure 3a. shows results obtained for various specifications of the riser top pressure.

From this figure, it can be deduced that well 2 is the less “eruptive” one. The eruptivity limit correspond to the first null value of pressure drop (choke completely open), when the pressure specification increases. It can also be shown that a specification up to 25 bar is physically impossible to reach without activation system such as gas-lift (recycle) or pumping.

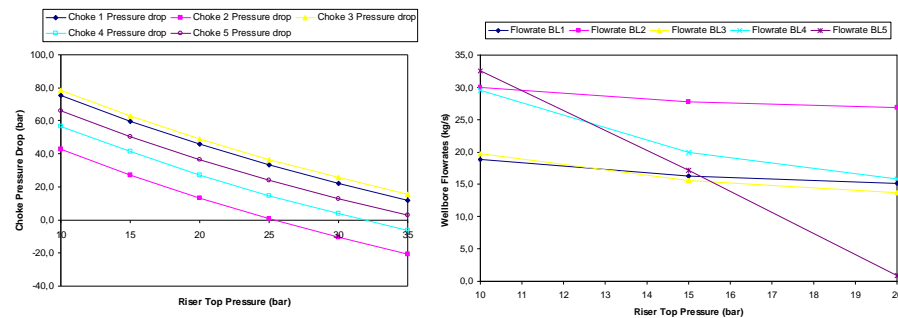

Figure 3.: Results from various riser top pressure specifications  
a. (left): Cases without recycle – FP strategy b. (right): Cases without recycle – PP strategy

## Pressure-driven Steady-State Simulation of Oilfield Infrastructure

Two other flowrate/pressure problems have been solved, in which the action variables are on the one hand the four pressure drops of the more eruptive wells and the flowrate of the less eruptive one (i.e. well 2, for this base case) and on the other hand the five bottom hole pressures for fixed choke pressure drops. Finally, a last case without recycle consists in a pressures/pressure problem, in which the action variables are the well flowrates for fixed choke pressure drops. This case converges less easily, because of the flowrates and pressure drops initialisation that may induce physical impossibilities (manifolds unbalanced). In figure 3b, we can see flowrates out of the five wells *versus* the riser top pressure specification.

### 4.2. Case Studies with recycle

When gas-lift is mandatory, flowrates/pressure and pressures/pressure problems are also solved. For the first problem type, the action variables may be the pressure drops of the four chokes (on the most eruptive wells) and the flowrate of recycle (gas-lift) to the riser bottom, the less eruptive choke being completely open. Figure 4 shows typical results in which we can see that there is no need for gas-lift under a threshold of approximately 25 bar.

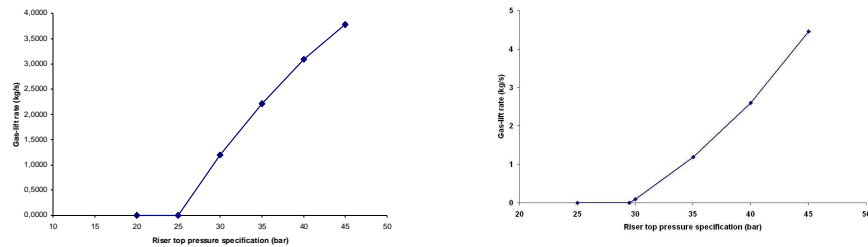

Figure 4. : Cases with recycle – FP strategy Results from various riser top pressure specifications  
a. (left) ProsimPlus™ results b. (right) INDISS-TINA results

Same kind of results can be obtained for the second problem type with, potentially, the same convergence difficulties than cases without recycle.

### 4.3. CAPE-OPEN integration

The ProSimPlus™ SPEC module (design specifications and recycle streams solver) has been made compliant with CAPE-OPEN (CO) Unit Operation 1.0 interface specification using the technology described in [4]. Both SPEC and the IFP pipeline multiphase flow module are integrated in INDISS-TINA environment as CO compliant Unit Operations. INDISS™ is the dynamic simulation platform chosen by TINA to provide a consistent set of data along the fluid line from wellbore to export facilities. INDISS™ is developed by RSI and respects the CAPE-OPEN standard for thermodynamic property servers as well as for static and dynamic unit operations [5]. Some specific developments have been implemented within INDISS™ to order sequential calculations and to deal with the ProSimPlus™ SPEC module for simultaneously solving equations associated to design specifications and recycle streams.

The previous simulations performed with ProSimPlus™ can be performed with INDISS-TINA by using the more sophisticated steady-state IFP pipe module based on a 1D Computational Fluid Dynamics approach [6-7].

Figures 5. and 4b. illustrate the results obtained with INDISS-TINA on the same previous specified cases (figures 3. and 4a.).

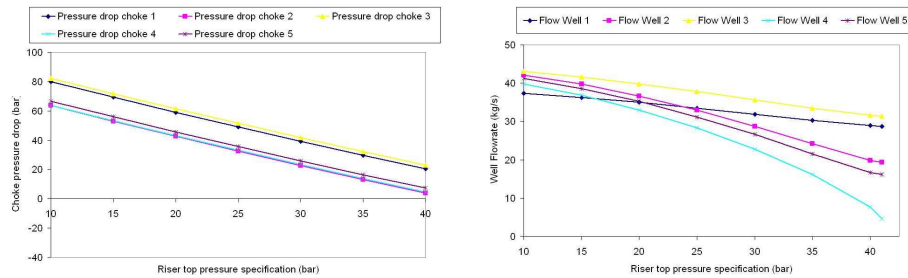

Figure 5.: INDISS-TINA results from various riser top pressure specifications  
 a. (left): Cases without recycle – FP strategy b. (right): Cases without recycle – PP strategy

The main difference between results from ProSimPlus™ and results from TINA are due to the different pipe modules used, initial chokes settings and well fluid characterizations.

## 5. Conclusions and future work

In conclusion, this study pointed out two major elements. First, classical CAPE tools, such as ProSimPlus™, are able to solve efficiently, in a context of pressure-driven process models, steady-state simulation encountered in oil & gas production. Secondly the CAPE-OPEN standards are the best way to “plug and play” software components from various sources (i.e. ProSimPlus™ process simulator and IFP) into another one (i.e. INDISS™). Future work concerns multi-period optimization and dynamic simulation problems.

## References

- [1] Joulia X., Koehret B., Enjalbert M., The Chemical Engineering Journal, 30, 3, 113-127 (1985)
- [2] Broyden G.C., Math. Comp., 19, 577-593 (1965)
- [3] Broyden G.C., Comp. J., 12, 94-99 (1969)
- [4] R. Morales-Rodriguez, M. Sales-Cruz, R. Gani, A. Vacher, S. Déchelotte, O. Baudouin, AIChE Annual Meeting: Conferences, 13-17 November, San Francisco (2006)
- [5] P. Roux (IFP), D. Paen (RSI), 10th CO-LaN annual meeting 2005
- [6] Pauchon C., Dhulesia H., Lopez D. and Fabre J., 6th BHRG Multiphase International Conference 1993, Cannes, France, June 1993.
- [7] Henriot V., Pauchon C., Duchet-Suchaux P. and Leibovici C., OTC 1997 (n° 8563) 1997 Houston, mai 1997