

CNN demosaicking generalizes for any CFA

Lise Y. Bourrier¹, Marina Reyboz², Martial Mermillod¹, David Alleysson¹

¹ Univ. Grenoble Alpes, Univ. Savoie Mont Blanc, CNRS, LPNC, 38000 Grenoble, France.

²Univ. Grenoble Alpes, CEA, LIST, 38000 Grenoble, France.



Context - Demosaicking

Acquiring image: single sensor imaging (mimetic with human vision)

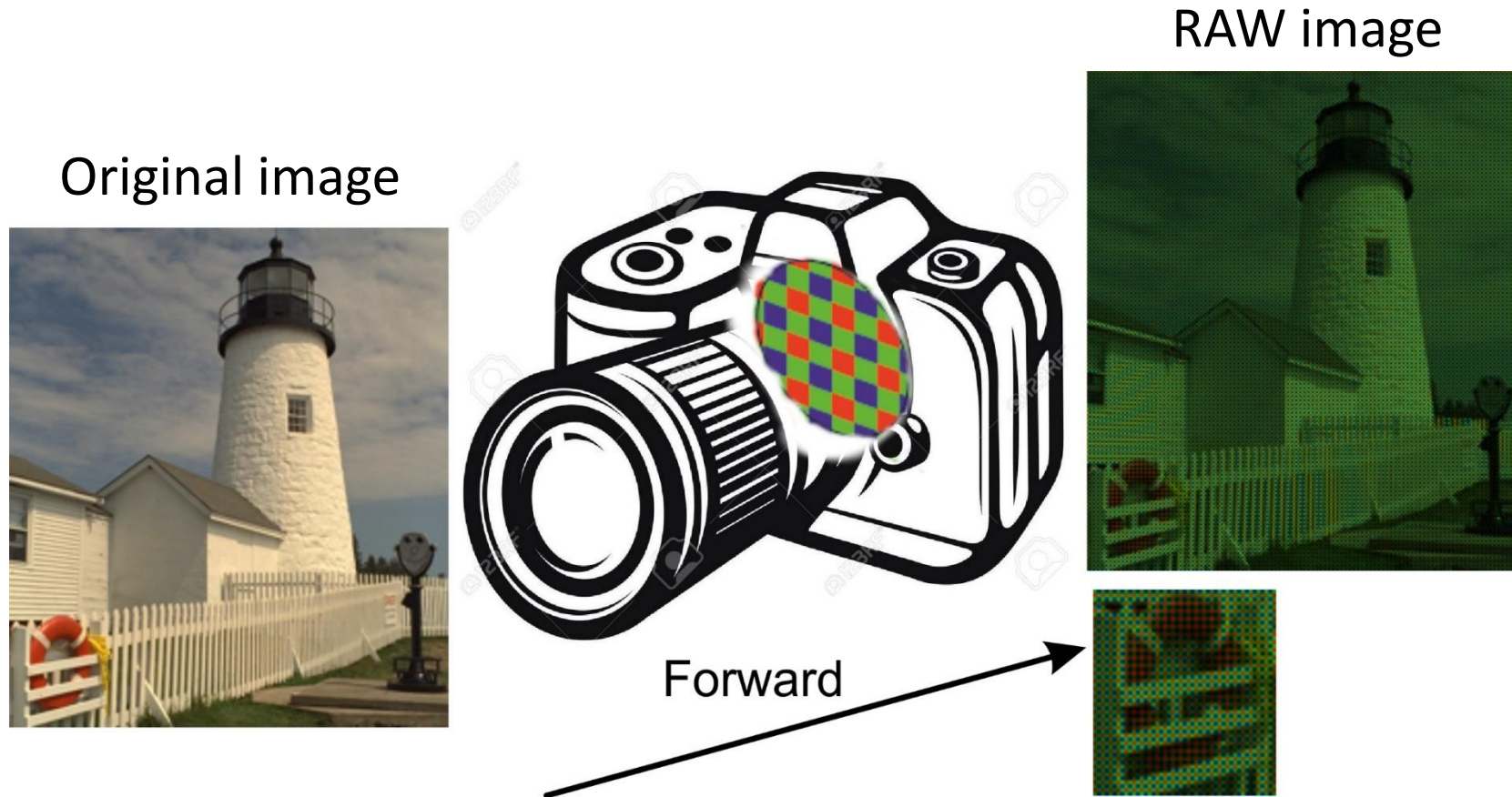

Context - AI

- Inverse system: finding the color image that the camera projects onto the mosaic image.

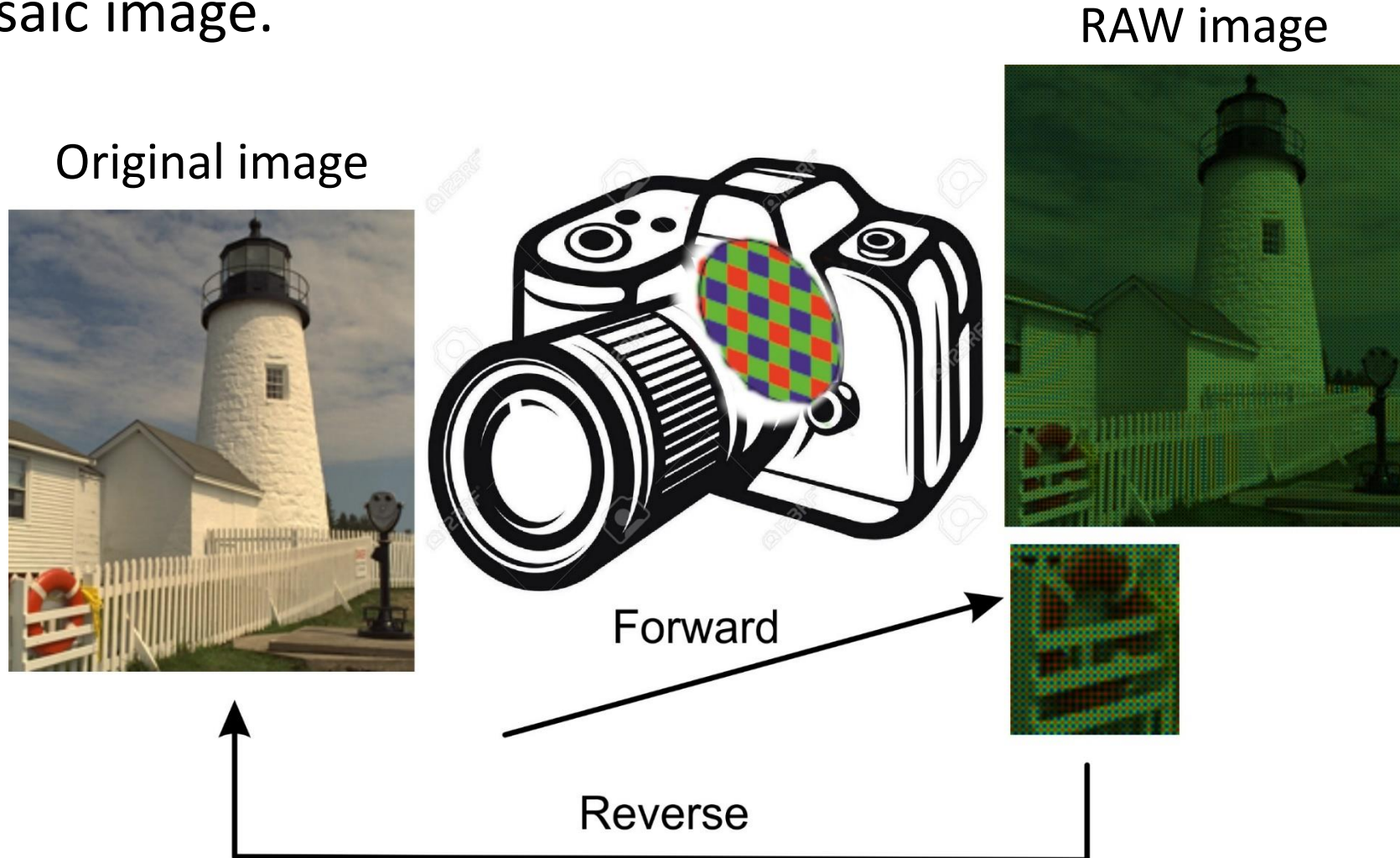

Solution 1: Linear demosaicking

- Why linear ?

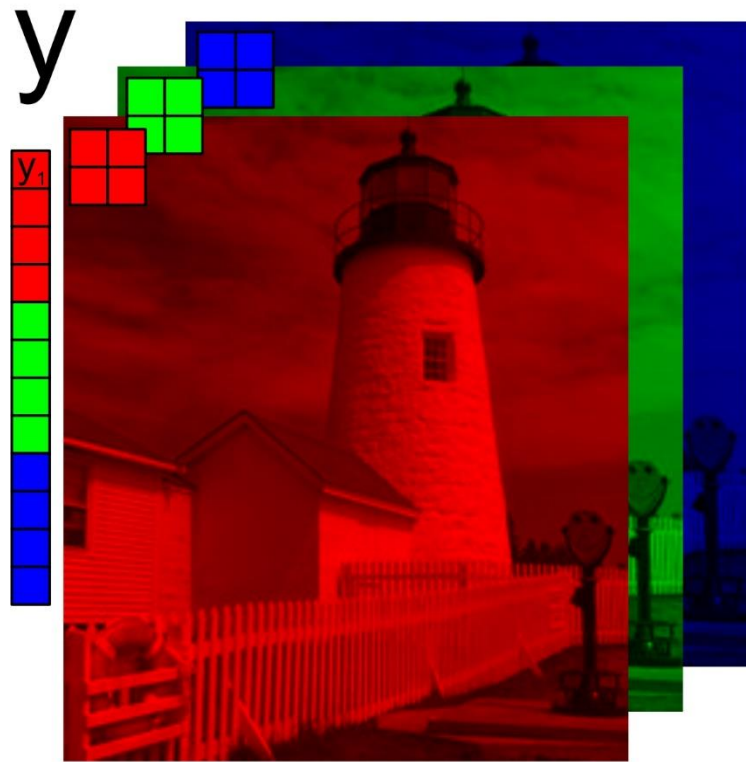

$$x = My$$

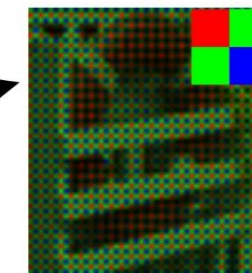
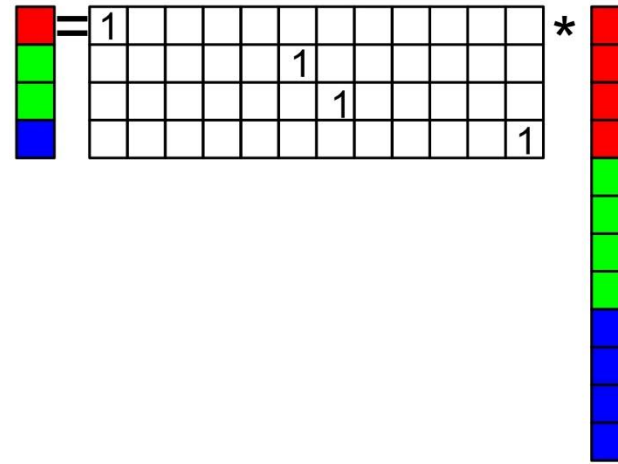

x

If the operator is linear and the estimator is the mean square error, then LMMSE (Linear Minimum Mean Square Error) estimation is a direct solution.

Solution 1: Linear demosaicking

- From a cloud of color images

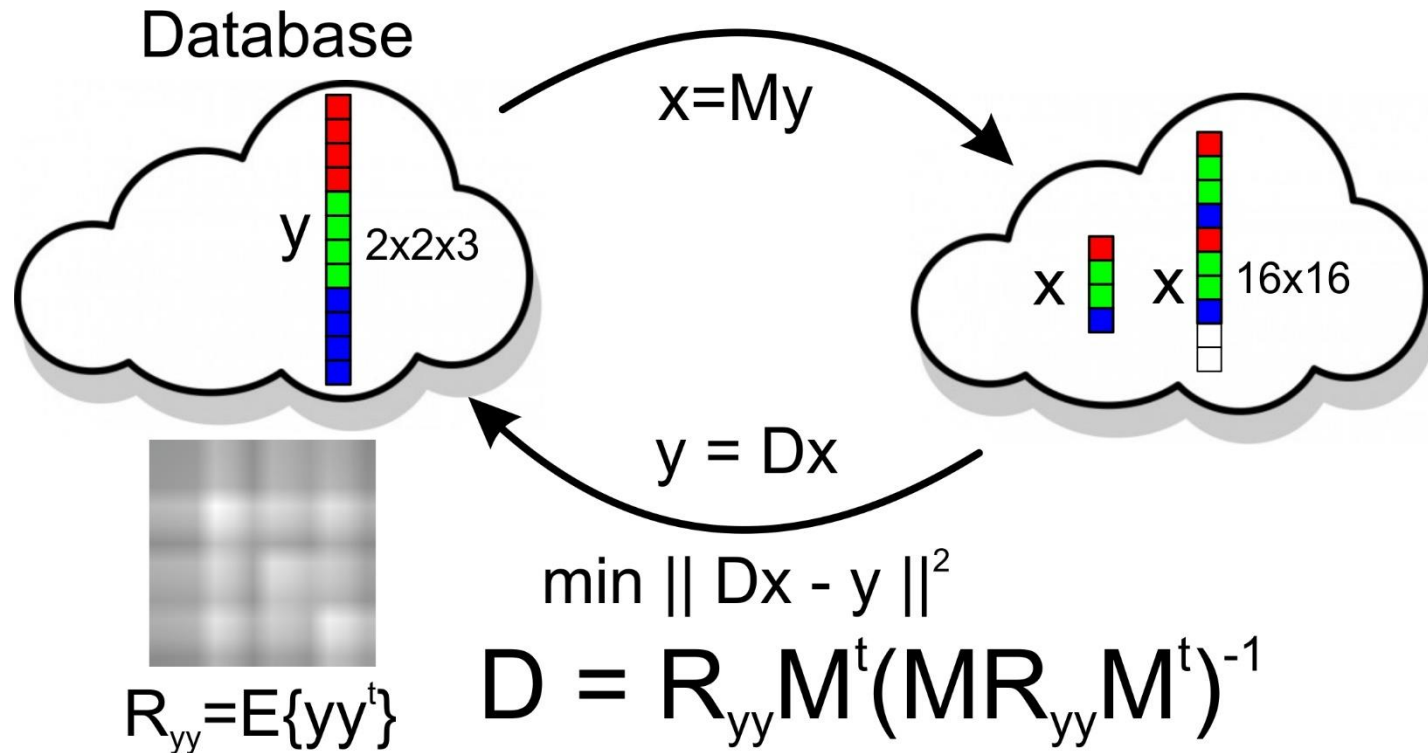

Using neighborhood in RAW image for regularization

- One solution for a given database
- Few images to learn
- Low cost solution (to learn and test)
- Scalable solution $n_h * n_w \times n_{hp}$

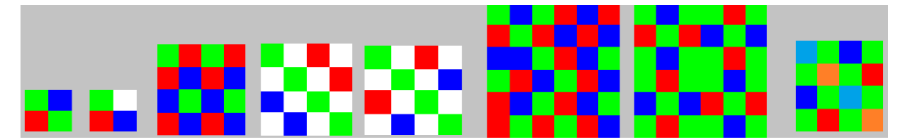

- Works well for Hyperspectral imaging
- Can handle random mosaic by local processing

PSNR = 40 dB

for 4x4 #2 on Kodak

Amba & al., CIC 2016

Other solutions: Non-linear operators

- Many of them: ANN (Artificial NN), CNN (Convolutional NN) with MSE (Minimum Square Error).

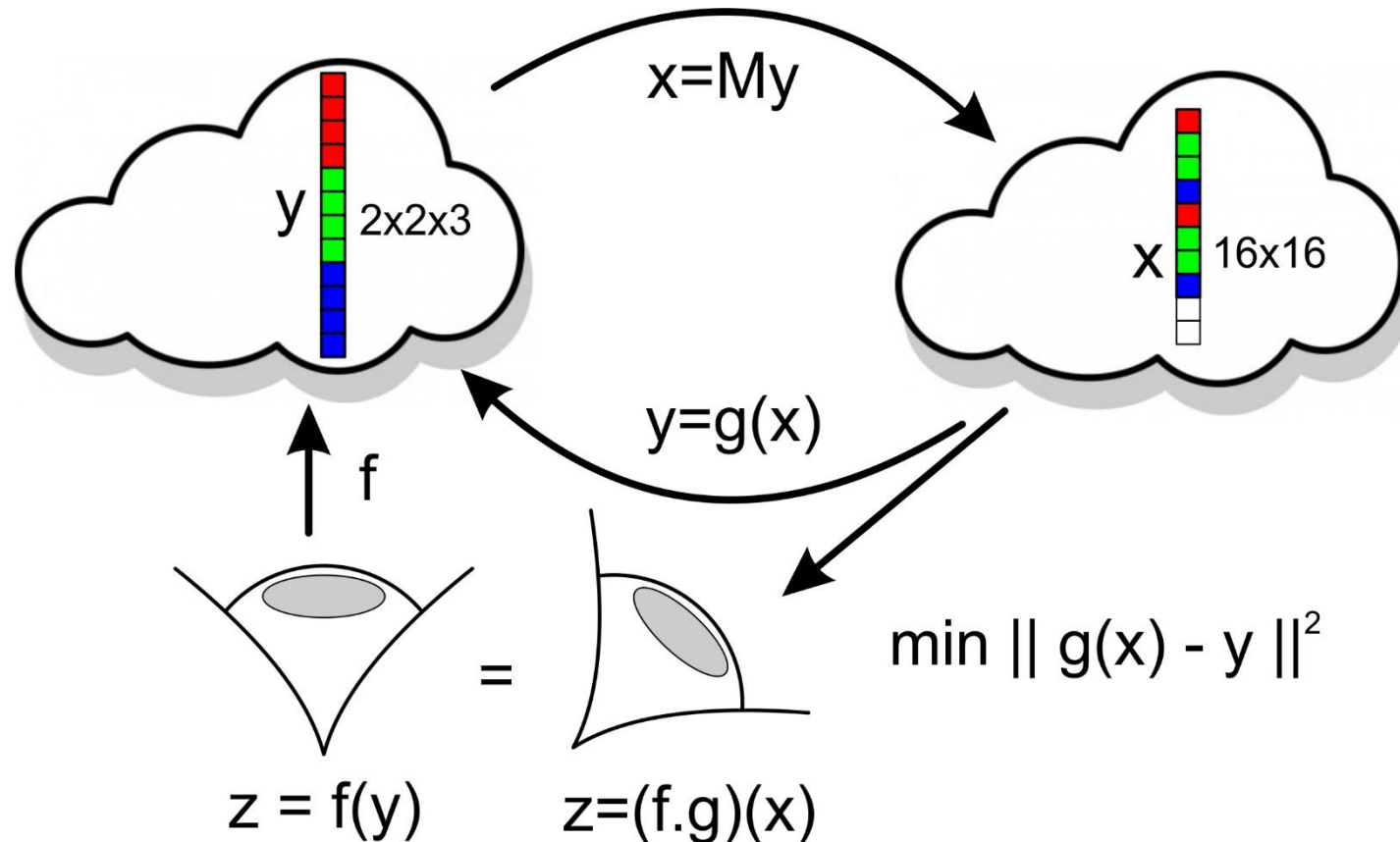

$$\min \| g(x) - y \|^2$$

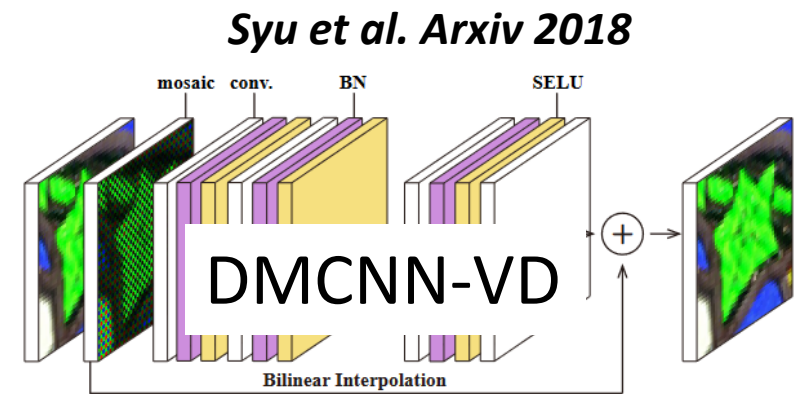
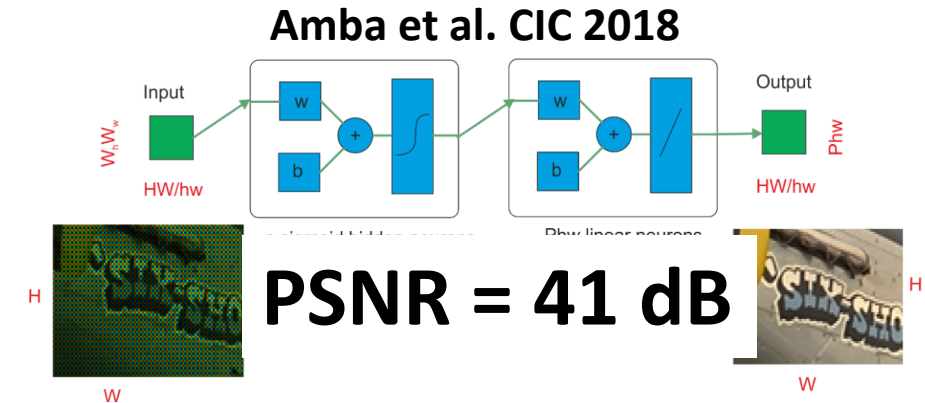

What we did

- A CNN with bottleneck

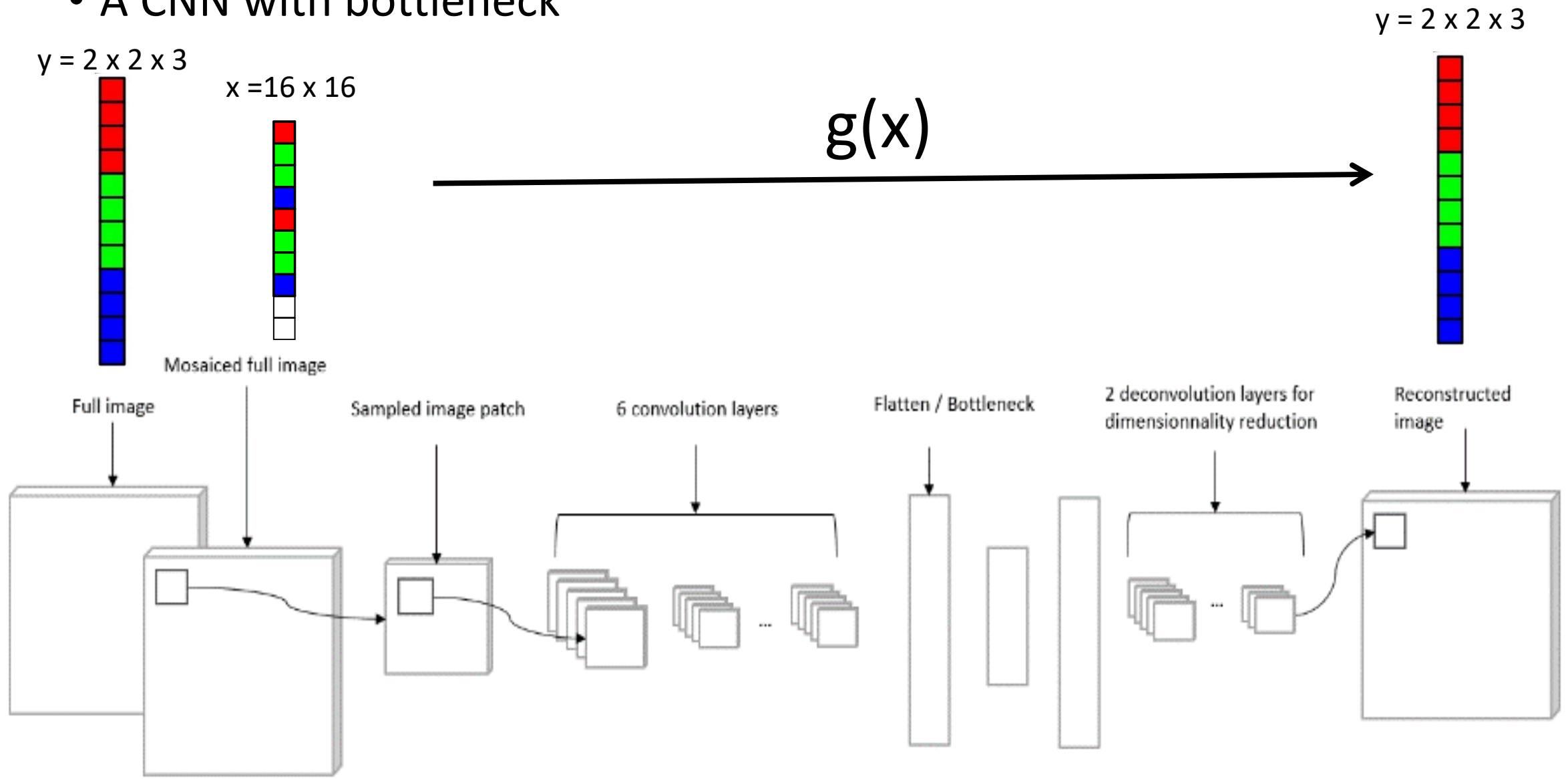

Experiment 1

Periodic CFA

Random CFA

Train

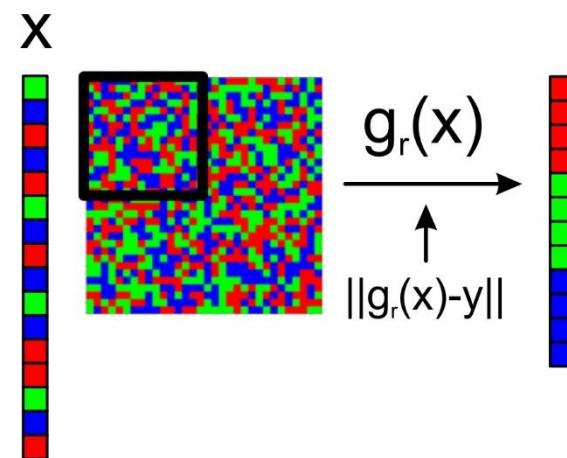
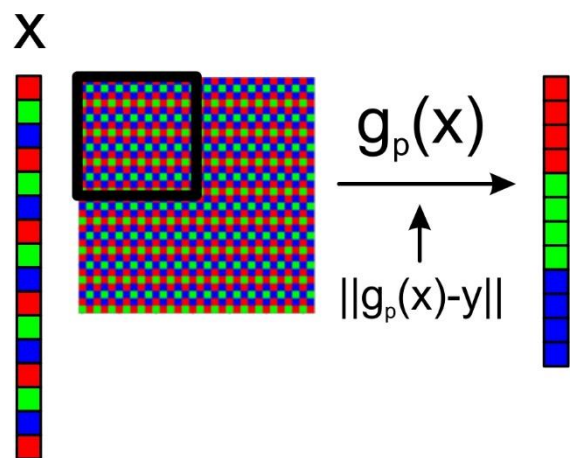

Test

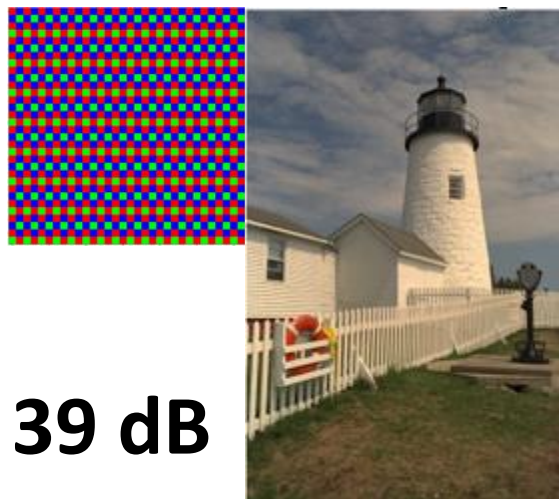

PSNR = 39 dB

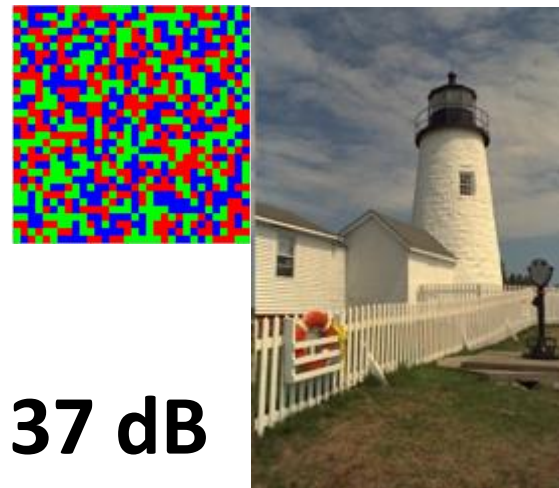

PSNR = 37 dB

Is it working?

- Image degradation

Random Learning

Periodic Learning



Experiment 2

- Cross testing CFA arrangement

Learnt random

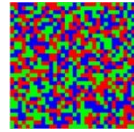

Learnt periodic 4x4 #2

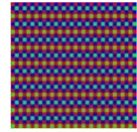

4x4 #2

New random

Bayer

4x4 #2

New random

Bayer

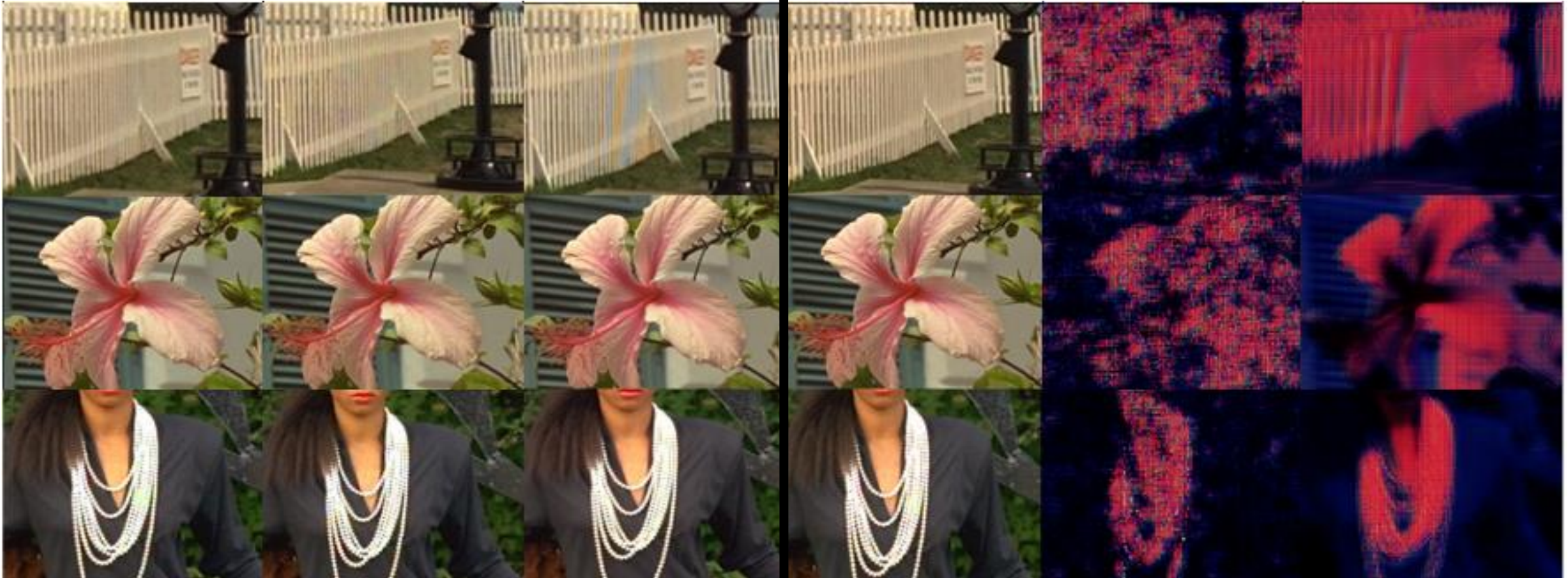

Why it works ?

- Network found local trajectories

**Periodic
Learning**

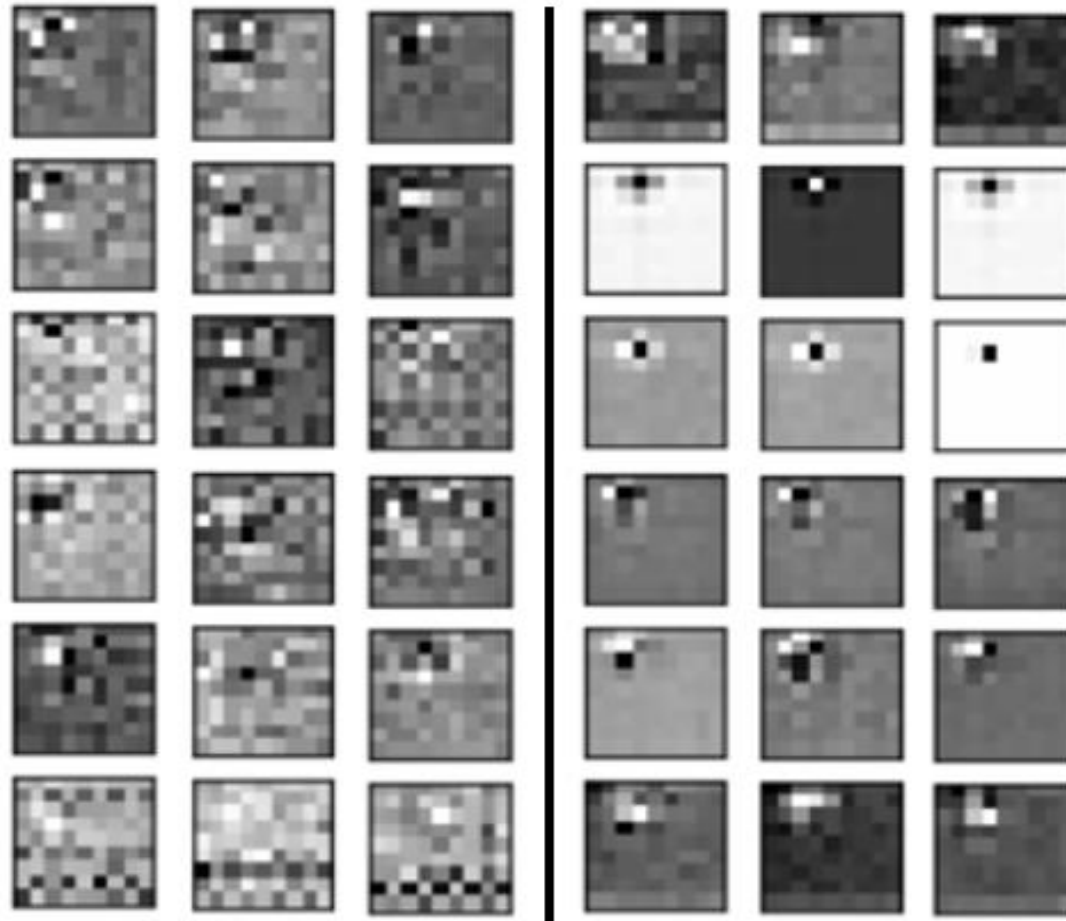

**Random
Learning**

Filters of the first convolutional layer

Universality ?

- For a given problem (a particular CFA) optimal solution is found empirically (e.g. Bayer), from adequate processing (i.e. universal demosaicking) and universal processing (a single process for all problems).

	LMMSE	Universal	Our CNN Periodic	Our CNN Random
Same code with different CFA				x
Different code with different CFA	x	x	x	
Deterministic solution	x	x		
Learning capability	x		x	x

What does that mean?

- There probably exists a universal processing for demosaicking. That produces the desired image. A potential candidate for retinal demosaicking. But at the speed of biological process, not CNN.

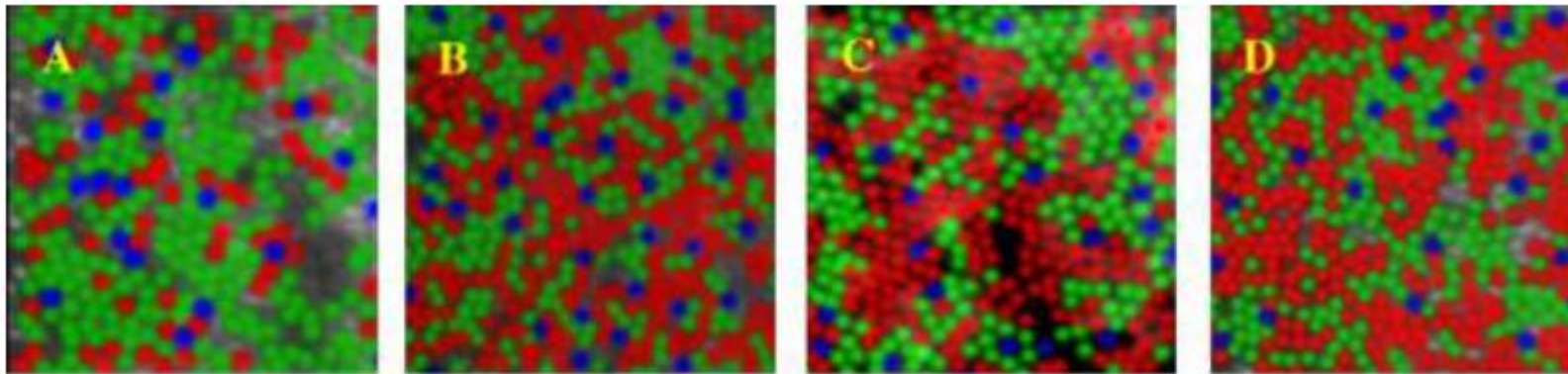

- A local solution can be an efficient solution.
- Relaxing constraints in CFA fabrication.
- Perspective: confirming robustness property against illumination