



HAL
open science

Centralized vs distributed communication scheme on switched ethernet for embedded military applications

Ahlem Mifdaoui, Fabrice Frances, Christian Fraboul

► To cite this version:

Ahlem Mifdaoui, Fabrice Frances, Christian Fraboul. Centralized vs distributed communication scheme on switched ethernet for embedded military applications. IEEE Symposium on Industrial Embedded Systems (SIES 2009), IEEE, Jul 2009, Lausanne, Switzerland. pp.201-210, 10.1109/SIES.2009.5196216 . hal-04029843

HAL Id: hal-04029843

<https://hal.science/hal-04029843v1>

Submitted on 15 Mar 2023

HAL is a multi-disciplinary open access archive for the deposit and dissemination of scientific research documents, whether they are published or not. The documents may come from teaching and research institutions in France or abroad, or from public or private research centers.

L'archive ouverte pluridisciplinaire **HAL**, est destinée au dépôt et à la diffusion de documents scientifiques de niveau recherche, publiés ou non, émanant des établissements d'enseignement et de recherche français ou étrangers, des laboratoires publics ou privés.



This is a publisher-deposited version published in: [http://oatao.univ-toulouse.fr/Eprints ID: 2238](http://oatao.univ-toulouse.fr/Eprints/2238)

To cite this document: MIFDAOUI, Ahlem. FRANCES, Fabrice. FRABOUL, Christian. Centralized vs distributed communication scheme on switched ethernet for embedded military applications. In: *IEEE Symposium on Industrial Embedded Systems*, 08-10 july 2009, École Polytechnique Fédérale de Lausanne, Switzerland.

Any correspondence concerning this service should be sent to the repository administrator: staff-oatao@inp-toulouse.fr

Centralized vs Distributed Communication Scheme on Switched Ethernet for Embedded Military Applications

Ahlem Mifdaoui
Toulouse University
ISAE
1 place Emile Blouin
31056 Toulouse, France
Ahlem.Mifdaoui@isae.fr

Fabrice Frances
Toulouse University
ISAE
1 place Emile Blouin
31056 Toulouse, France
Fabrice.Frances@isae.fr

Christian Fraboul
Toulouse University
ENSEEIH/IRIT
2 rue Charles Camichel
31071 Toulouse, France
Christian.Fraboul@enseeiht.fr

Abstract— Current military communication network is a generation old and is no longer effective in meeting the emerging requirements imposed by the future embedded military applications. Therefore, a new interconnection system is needed to overcome these limitations. Two new communication networks based upon Full Duplex Switched Ethernet are presented herein in this aim. The first one uses a distributed communication scheme where equipments can emit their data simultaneously, which clearly improves system's throughput and flexibility. However, migrating all existing applications into a compliant form could be an expensive step. To avoid this process, the second proposal consists in keeping the current centralized communication scheme. Our objective is to assess and compare the real time guarantees that each proposal can offer. The paper includes the functional description of each proposed communication network and a military avionic application to highlight proposals ability to support the required time constrained communications.

I. INTRODUCTION

Current military communication network uses various interconnection systems, like MIL STD 1553B, STANG 3910 and SCI links [1]. Some of these data buses were designed since the 1980's and are still used in many military applications like aircraft, ships and satellites. However, with the increasing number and complexity of subsystems, these interconnection systems are a generation old and may be no longer effective in meeting emerging requirements. Using these solutions makes the global interconnection system heterogeneous and complex, and real-time constraints guarantees difficult to prove. Clearly, a new interconnection system is needed to fulfill these requirements. Currently, there is a new trend to use commercial off the shelf (COTS) technology rather than designing a dedicated solution. The use of a widely implemented and mature technology will greatly reduce the development cost and facilitate the maintenance process. However, the problem with COTS is reconciling the different requirements of commercial and critical applications.

Among several high speed COTS networks, Switched Ethernet is incontestably the most cost effective solution thanks to its ubiquity, simplicity and maturity. Therefore, this protocol is put forward in this paper as an attractive candidate to be the

new communication network for the next generation embedded military applications. However, the key argument against using Switched Ethernet in this context lies in its non deterministic behavior that makes it inadequate to deliver hard real time communications due to congestion occurrence in switches. Therefore, achieving a real time behavior with low latency over Switched Ethernet still needs the use of specific real time mechanisms. Various real time communication solutions have been recently offered for Switched Ethernet. An overview of these solutions can be found in [2] and [3].

In this paper, two communication networks based upon Full Duplex Switched Ethernet are proposed to replace the current military network. This aims at overcoming existent limitations and fulfilling the increasing needs of new military applications. The first one uses a distributed communication scheme where equipments can emit their data simultaneously. This solution, based on the Traffic Shaping approach, improves global throughput and system's flexibility. However, the existing subsystems are implemented to work with a centralized communication scheme, due to the widely used command/response data bus MIL STD 1553B [1]. Therefore, migrating all existing applications into a distributed communication compliant form could be an expensive step. To avoid this process, the second proposal consists in keeping the current centralized communication scheme thanks to an optimized Master/Multi-slave transmission control initiated within the Flexible Time Triggered (FTT) paradigm [4].

Our objective in this paper is to assess and compare the hard real time guarantees that each proposal can offer. First, the functional description of each proposed communication network is provided. Then, performance analysis is conducted, using the Network Calculus, in the case of a realistic military application. Obtained results are compared to show each proposal's ability to satisfy the required real time constraints. In the next section, a brief examination of data communication requirements for embedded military applications and an overview of the Traffic Shaping technique and the FTT paradigm are presented, while in section 3 we review the most

relevant approaches to provide real time communication over Switched Ethernet and relate them to our work. Section 4 and section 5 give an overview and a functional description of the two proposals, respectively. Obtained results for the considered case study and comparative analysis are then presented in section 6.

II. BACKGROUND

A. Military applications requirements

For embedded military applications, it is essential that the networking system fulfills a set of requirements, e.g. the timeliness and the accuracy of data which are critical for safety concerns. Therefore, the determinism of the data bus and temporal deadlines guarantees are very important. Moreover, these applications need several classes of traffic and priority control with guaranteed qualities of service for each traffic class. Several kind of traffic can be identified regarding their temporal characteristics.

- Periodic traffic: corresponds to e.g a control process and it is in general known a priori.
- Hard Real Time (HRT) Aperiodic traffic: corresponds to e.g alarms that are sent asynchronously and have to be received under a predefined bounded time.
- Soft Real Time (SRT) Aperiodic traffic: corresponds to e.g a configuration process which is also asynchronous but has not to respect strict time constraints.
- Non Real Time (NRT) traffic: results from e.g file transfers and has no time constraints.

B. Traffic Shaping

Our proposal with a distributed communication scheme is based on the Traffic Shaping approach. This technique has been initiated by Kweon and Shin [5] to achieve real-time communication over Ethernet.

The traffic shaping idea is that reliable transmission with bounded delays is possible when there is a traffic control at data sources. Each subsystem has to control its streams in accordance with their periodicity and their packet's maximal length. The traffic shaper regulates a packet stream using a leaky bucket concept characterized by a maximal size and a rate carefully chosen for each stream. As opposed to the current centralized transmission control, Switched Ethernet with Traffic Shaping approach is based on the fact that equipments can emit their data simultaneously when the traffic is well controlled, which improves global throughput and system's flexibility.

C. FTT paradigm

Our proposal with centralized communication scheme is based on the Master/Multi-slave mechanism. This latter has been initiated by Almeida, within the Flexible Time Triggered (FTT) paradigm and its implementation on CAN (FTT CAN [4]), to allow an efficient use of network bandwidth and save overhead compared to standard Master/Slave protocols since the same master message is used to poll several nodes in a given Time Cycle.

The master addresses several slaves with a single Trigger Message (TM) at the beginning of each Elementary Cycle (EC). This latter is a fixed time slot used to allocate traffic on the bus; and within each EC two windows are considered synchronous and asynchronous, dedicated to periodic and aperiodic traffic, respectively (figure 1). The Trigger Message synchronizes the network and allows the identification of the periodic messages that must be transmitted by the remaining nodes within the respective EC. Nodes decode the TM and transmit immediately the identified messages. The periodic traffic scheduling activity is done centrally in the master, thanks to operational information stored in its System Requirements Database. This fact makes easy the scheduling policy choice and the communication requirements alteration.

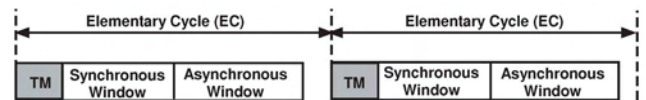

Fig. 1. Elementary cycle structure

III. RELATED WORKS

A. Traffic Shaping approach

Traffic Shaping approach has been initiated by Kweon and Shin [5] and their idea is that a smooth traffic, in which messages arrive at a constant rate, suffers less from collisions than a bursty traffic. Specifically, a traffic smoother is installed in every station between the Ethernet MAC layer and the UDP or TCP/IP layer: first it gives real-time (RT) packets priority over non real-time (NRT) packets, second it smooths the NRT-stream to reduce collision with RT-packets from the other nodes. Real-time traffic is not smoothed and is sent as soon as it arrives. This approach provides statistical guarantees which is not sufficient for hard real-time systems like the military applications.

Unlike this approach where only the non real-time traffic is smoothed, the Traffic Shaping approach developed by Loeser and Haertig [6] is based on the fact that all the incoming traffic has to be controlled in order to guarantee some deterministic performances of the network. They show in experiments, in the special case of Fast and Gigabit Switched Ethernet, that transmission without packet loss could be guaranteed when using the Traffic Shaping. However, this guarantee does not fulfill the military applications requirements and specially the deadline constraints.

This last approach presents a similarity with the one suggested in this paper, which consists in the use of traffic shapers at data sources to control traffic and to guarantee the integrity of the military applications. However, we will add a priority handling method in data sources and in the switch to assure a good isolation level for urgent messages with hard deadline constraints. Then, an adequate choice of service policy in the switch is needed to guarantee low bounded delays. Finally, to deal with the prediction of the worst case performance of such proposal, delay bounds analysis is conducted using the Network Calculus [7].

B. Master/ Slave approach

Despite some limitations like the existence of a single point of failure (master) and imposed overheads, the Master/Slave mechanism is still an attractive solution thanks to its centralized control that reduces traffic management on slaves. We review in this section the most relevant solutions using the Master/ Slave approach.

Ethernet Powerlink (EPL) is supported by the Ethernet Powerlink Standardisation Group [8]. It is based on the principle of using a Master/Slave mechanism on shared Ethernet segment. A key concept in this protocol is the EPL cycle which is a fixed time slot used to transfer traffic on the bus. The following time periods exist within one cycle: (1) Start period where the master sends a special frame to slaves to signal the beginning of the cycle; (2) Isochronous period to send and receive isochronous traffic; (3) Asynchronous period to transfer only one asynchronous message; (4) idle period used to assure the temporal isolation between isochronous and asynchronous data. "This protocol offers hard guarantees for the preplanned traffic and soft guarantees for the on demand traffic" [3]. However, this protocol is not compatible with regular 802.3 protocol and it is not implemented yet on Switched Ethernet.

EtherCAT is supported by the EtherCAT Technology Group [9]. The medium access control uses a Master/Slave principle where slaves are arranged in an open ring bus and the master is connected to one of the open ends. Frames can be processed "on the fly" where the master sends frames to the slave nodes to extract data from and insert data into these frames. This configuration offers good performance with very short cycle times ($30\mu\text{s}$) [2]. However, this protocol is based on non standard hardware which conflicts with the main interests of using Ethernet in real time applications e.g costs, availability and compatibility.

The FTT paradigm has been extended to Ethernet by Pedreiras (FTT Ethernet [10]) and recently to Switched Ethernet by Marau (FTT-SE [11]). This protocol presents significant interests compared to EtherCAT and EPL thanks to its optimized transmission control (Master/Multi-slaves), its flexibility and its compatibility with 802.3 protocol. However, we identify some limitations of the current FTT-SE version [11] (version in progress) to be used in a hard real time context. First, there is not a clear mechanism to handle aperiodic traffic and to avoid unconstrained aperiodic communication occurrence yet. This fact may generate bursts leading to queue overflow in switches and packet losses and consequently real time constraints violation, which is not allowed for embedded applications. Then, to our best knowledge, the schedulability analysis and the temporal accuracy of the system are not proved yet.

This last protocol presents a similarity with the one suggested in this paper which consists in the use of a Master/ Multi-slave technique to save overhead compared to a standard Master/Slave technique. Taking advantage of these FTT paradigm characteristics, we propose a new Master/ Multi-slave Switched Ethernet that differs from the FTT-SE [11]

in many aspects. In fact, one of the major characteristics of FTT-SE is its Flexibility which consists in using an on-line admission control and a dynamic QoS management. However, for embedded military applications, the circulating traffic is known a priori and using a scheduling mechanism computed off-line and implemented statically in the master is more suitable for predictability reasons. The originality of this choice lies in the introduced schedulability analysis based on the Network Calculus theory [7] to provide deterministic schedulability guarantees. Moreover, our proposal implements different enhancements to overcome the cited FTT-SE's limitations.

IV. PROFILED NETWORK WITH DISTRIBUTED COMMUNICATION SCHEME

A. Overview

To achieve the required QoS level offered by Switched Ethernet, the key of this proposal is the use of traffic shapers at data sources to control traffic and an adequate switch service policy to guarantee the real time constraints of these critical applications. Note that today's switches like the recent Cisco ones offer interesting features like advanced QoS. These switches implement Priority handling (IEEE 802.1p) to classify packets and can support processing up to four queues per output port. In addition, Cisco switches support the widely used scheduling policies like First Come First Served (FCFS) and Static Priority (SP) .

B. Functional description

The functional diagram of this profiled network is shown in figure 2. Each subsystem is connected to the network via a specific terminal that provides communication functions required to use the network. Different terminals are connected to a central switch using a static forwarding table to transmit data from one terminal to another. End to end communications are based upon three parts: Application interface (API), UDP/IP protocols and enhanced Ethernet layer. The API provides a set of services to send and receive messages, using the correspondent communication port number and a pointer to the queue holding the message to transmit or waiting to be read. This API is very similar to the socket API. The Transport and Network protocols UDP/IP are selected for their simplicity to provide end to end services between application processes. To perform the system configuration, an UDP port number is associated with each used communication port in the API, and each transmitted or received message type has a correspondent UDP port. Hence, the avionic subsystem identifies exchanged data thanks to communication ports numbers.

The Ethernet layer is enhanced thanks to the traffic shaping and the scheduling policies implementation:

- *Traffic Shaping implementation*

Traffic Shaping is implemented in the upper half of the Data Link Layer, using the leaky bucket concept. A leaky bucket is characterized by a maximal size b and a rate r and a correspondent traffic shaping interval T can be defined: once the bucket gets empty, the next amount

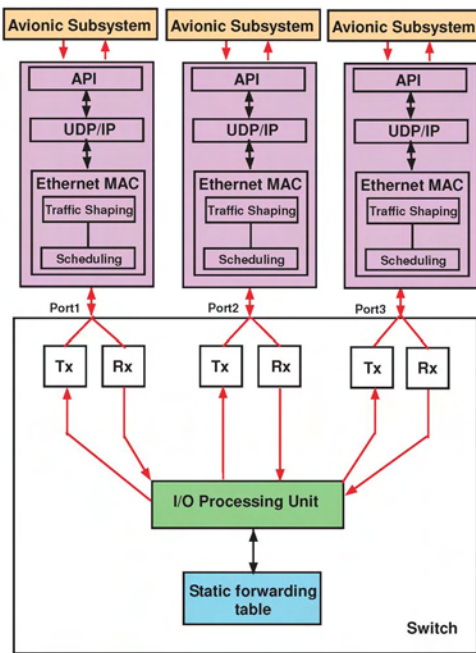

Fig. 2. Functional Diagram of Switched Ethernet with a distributed communication scheme

of data is generated not earlier than T . So, the bucket must hold at least the amount of data $r * T$ that can arrive during T time units. To guarantee the integrity of the traffic characteristics, we consider for each stream a leaky bucket characterized by its maximal size L and its rate L/T in order to have one packet of size L per period T .

- *Scheduling implementation*

After traffic regulation, flows are multiplexed in the terminal output according to the processing policy and only FCFS and SP are considered in our case. A priority mechanism is defined in this aim to take into account the different temporal constraints of each traffic category. As a result, we define four priorities: HRT aperiodic traffic will be tagged with the highest priority, then periodic traffic the medium priority, and the lowest priorities for the SRT aperiodic and NRT traffic. The terminal processing policy and the switch scheduling policy have to be the same.

C. Switch specification

An Ethernet switch is an active device that identifies the destination port of an incoming packet and relays it to the specific port [12]. If multiple packets have the same destination port, buffers are used to resolve the problem of collision. However, frames are lost when buffers overflow. Ethernet switches can be identified by their switching technique and their scheduling policy.

First, two types of switching techniques are currently implemented in Ethernet switches: *Cut Through* and *Store and Forward*. With the first, only the header of each packet is

decoded to determine its destination port and the rest is forwarded without any error checking mechanism. With the latter, the switch waits until the complete reception of the packet and forwards it to the destination port if it is successfully verified. For military applications, it is more convenient to implement the second switching technique for safety reasons since no corrupted packet will be forwarded. Then comes the scheduling policy which will be used to forward packets at the switch output port. Two basic scheduling policies are widely used FCFS and SP.

- FCFS is the simplest policy. Packets are served in their arrival order without taking into account their temporal characteristics and mainly their deadlines, which can cause real-time constraints violations.
- Using SP, packets are queued and forwarded according to their priorities. So, a queue is selected for transmission if all traffic classes queues with higher priority are empty at the time of selection; and for a given queue, the scheduling order is FCFS with a non-preemptive manner. The 802.1p priority model [12] which defines a 3 bits priority field in the extended Ethernet frame (8 priority levels), is used to manipulate priority classes. Starvation for the lowest priority queues represents the main SP policy drawback.

V. PROFILED NETWORK WITH CENTRALIZED COMMUNICATION SCHEME

Current applications are used to working with the command/response mechanism and can have some adaptation problems with the new asynchronous communication scheme imposed by the profiled network presented earlier and a rewriting process could be necessary in this case. To overcome this limitation, Switched Ethernet with a centralized communication scheme is proposed herein to keep the current communication scheme. This fact guarantees an easy transition for existing applications and reduces development costs. Our proposal implements an optimized Master/Multi-slave transmission control technique to allow an efficient use of network bandwidth, combined with an original method to handle aperiodic requests and deterministic scheduling analysis to satisfy the required real time constraints.

A. Handling periodic transmissions

Concerning periodic traffic, the arbitration mechanism is guaranteed by the master given the information stored in its *Database* and our introduced *scheduling mechanism*. The master builds the periodic traffic schedule in a static manner according to the provided scheduling mechanism. Then, it polls several slaves by means of the Trigger Message (TM) which conveys the identification of the messages to transmit within each synchronous window. In the following paragraphs, we detail the used database and the scheduling mechanisms used inside the master.

1) *System Requirements Database*: The communication system management is guaranteed thanks to a data structure stored in the master node, called System Requirements Database (SRDB). This latter contains information concerning periodic traffic, aperiodic traffic and system configuration. In our case, the used cooperation model is the publisher/subscriber scheme. Thus, the identification of each message needs the associated physical addresses (source and destination). The description of periodic and aperiodic messages conveyed by the communication system is given in Periodic Requirements Table (PRT) and Aperiodic Requirements Table (ART), respectively.

$$PRT = \{PM_i(L_i, D_i, T_i, S_i, R_i), i = 1..N\}$$

$$ART = \{AM_i(L_i, D_i, T_i, S_i, R_i, P_i), i = 1..M\}$$

where

- i : message identifier used by the master to select transmitted messages and build the Trigger Message (TM);
- L_i : message maximal length in bytes. This information is necessary to select messages and guarantee temporal isolation between synchronous and asynchronous windows;
- D_i : message deadline. it is the period for a periodic message and the maximal response time for an aperiodic message;
- T_i : for a periodic message, it is the period. For an aperiodic message, it is low bounded as its minimal inter-arrival time. Aperiodic messages are then modeled as sporadic messages to assess the worst-case performances. This information is used to select periodic messages to transmit in each Elementary Cycle (EC) and to implement arbitration mechanism for aperiodic messages and specially traffic shapers integration;
- S_i : identifies the sender node;
- R_i : identifies destination address. It could be the address of one node or the group address of the receivers set. This information is used to build the Ethernet header;
- P_i : the priority level of an aperiodic message, that is determined by the real-time requirements of each aperiodic traffic category. This parameter is used for the aperiodic arbitration mechanism explained in V-B. Therefore, P_i is a natural in $\{0, 1, 2\}$.

The last component of the SRDB is the System Configuration Table (SCT), which contains information concerning the system status used to profile the network.

2) *Building EC-Schedules*: We define specific schedulability analysis carried out statically in the master that allows: (1) EC schedules building so that periodic (aperiodic) transmission fits within the synchronous (asynchronous) window; (2) schedulability bounds guarantee for each traffic class; (3) enforcing the temporal isolation between synchronous and asynchronous windows.

The originality of our introduced schedulability analysis consists in using the Network Calculus theory and optimization concepts. First, we identify the different temporal and

system constraints and we express them using the Network Calculus theory. The system constraints consist in the fact that both periodic and aperiodic messages should be confined within their respective windows to guarantee a traffic temporal accuracy and the system stability. Second, we extend this formalism by defining the guaranteed end to end delay bounds in a Master/ Multi-slave Switched Ethernet network. Third, we define a feasibility condition of a given schedule based on an optimization problem which takes into account the identified temporal and system constraints and has as decision variables Elementary Cycle and the synchronous window durations. The objective function of this optimization problem is the minimization of end to end delay bounds over all streams on the network. Our main idea is:

if the optimization problem associated to this scheduling problem admits a solution, then the schedule is feasible. If there is no admissible solution for the associated optimization problem, the network capacity is increased until finding an admissible solution.

This allows: (1) the definition of a feasibility condition for each considered schedule; (2) a worst case dimensioning of the network. Hence, the master becomes able to build feasible EC-schedules given the information stored in its Database and the knowledge of the optimal Elementary Cycle and synchronous window durations. The analytic details of this method are outside the scope of this paper and can be found in [13].

B. Handling aperiodic transmission

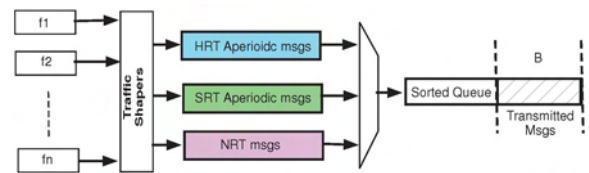

B: Traffic transmitted during Asynchronous Window

Fig. 3. Arbitration mechanism of aperiodic traffic

Unlike periodic traffic, the aperiodic traffic arbitration is not resolved by the master and the only information concerning this traffic conveyed by the TM is the asynchronous window duration. In order to avoid real time constraints violation, we introduce a suitable arbitration mechanism within the asynchronous window. Our main idea consists in constraining the amount of traffic generated within an asynchronous window thanks to the use of traffic shapers and a priority handling method combined with the service policy Static Priority (SP) to assure a good isolation level for urgent messages with hard deadline constraints. As a result, we define three priorities within aperiodic traffic: HRT aperiodic traffic will be tagged with the highest priority, then SRT aperiodic traffic the medium priority, and the lowest priority for the NRT traffic. Then, only the messages that fit within the asynchronous window and respect the system constraints are transmitted. The rest of the messages is kept until the following EC. Hence, the

aperiodic traffic arbitration is resolved in an autonomous way inside each node. Figure 3 illustrates this mechanism.

C. Functional description

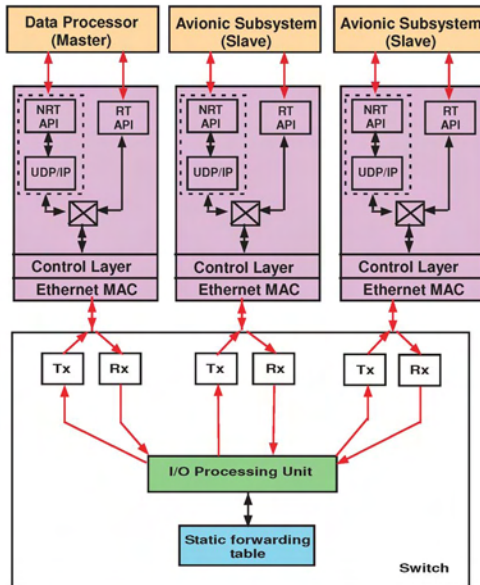

Fig. 4. Functional Diagram of Switched Ethernet with centralized communication scheme

The network architecture is depicted in figure 4 and it consists of one master and one or more slaves, connected to a central switch thanks to full duplex links. The switch is similar to the one specified for the profiled network using the distributed communication scheme (IV-C). Thus, it uses a static forwarding table and a store and forward switching technique and it implements FCFS and SP policies.

The access to the communication network is performed thanks to two parallel stacks, one for the Real Time traffic and the other for the Non Real Time one. The Non Real Time stack allows the coexistence of our protocol with other communication protocols thanks to an encapsulation process of foreign protocol frames within compliant frames. In this case, the UDP/IP protocols are used with a Non Real Time Application Interface (NRT API) to provide end to end communications. System configuration is performed in the same manner than the distributed network: each message type has a corresponding UDP port associated with a given API port.

The Real Time stack consists of three parts: Real Time Application Interface (RT API), a control layer and Ethernet MAC layer. The most important part is the control layer, integrated to the Data Link layer, to control both Real Time and Non Real Time communication.

- Trigger Message: this control layer decodes the TM, determines the master identifier and the synchronous and asynchronous windows durations. In addition, it identifies periodic messages to transmit by the associated terminal during the synchronous window.

- Periodic Traffic: on transmission, this control layer transmits messages identified by the TM message. On reception of a periodic message, it checks if it is correct and locally consumed. If it is the case, the associated buffer is updated with the received data.
- Aperiodic Traffic: on transmission, this control layer identifies the temporal limits of the asynchronous window and transmits the selected aperiodic messages according to the arbitration mechanism described in V-B. In addition, it prevents the start of any message transmission that does not fit within the asynchronous window to enforce temporal isolation between synchronous and asynchronous windows. On reception of an aperiodic message, it checks if it is correct and locally consumed. If it is the case, the message is transmitted to the corresponding communication stack (real time or non real time) and the associated buffer is updated with the received data.

It is worth to note that the arbitration mechanism used for aperiodic traffic is implemented in the upper half of the Data Link Layer, using traffic shaping based on Leaky Bucket concept and priority handling.

VI. PERFORMANCE EVALUATION

A. Metric: end to end delay

To investigate the validity of our proposals and their efficiency to support military applications requirements, the main metric that has been chosen is the end to end delay. To evaluate the offered QoS level, the maximal end to end delay bounds will be compared to the temporal deadlines of each traffic class. To achieve this aim, we have chosen to conduct an analytic study instead of simulations, which are commonly used to validate networks. In fact, simulations cannot cover the entire applicability domain and specially rare events that represent worst-case functioning. Moreover, these latter are always conducted with a given confidence level always less than 100 percent. So, clearly, simulations cannot prove the deterministic guarantees required by these critical applications, where a failure might have a disastrous consequence. Our analytic study is based on the use of *Network Calculus* theory [7], because it is well adapted to controlled traffic sources and provides deterministic end-to-end delay bounds.

In our previous works [13], [14] and [15], for each proposed network, general network models were designed to describe circulating traffic, the terminal and switch processing. Then, delay bounds analysis was conducted using the Network Calculus formalism based upon these models. These analytic studies details are outside the scope of this paper. In this part, these general analytic studies are applied in the case of a realistic military application to show and compare our proposals ability to provide deterministic guarantees.

B. Case study

Our case study is a representative circulating traffic on an avionic network in a modern French military aircraft. Hence, we estimate that it is representative of military applications behavior and requirements. The Network consists of six MIL

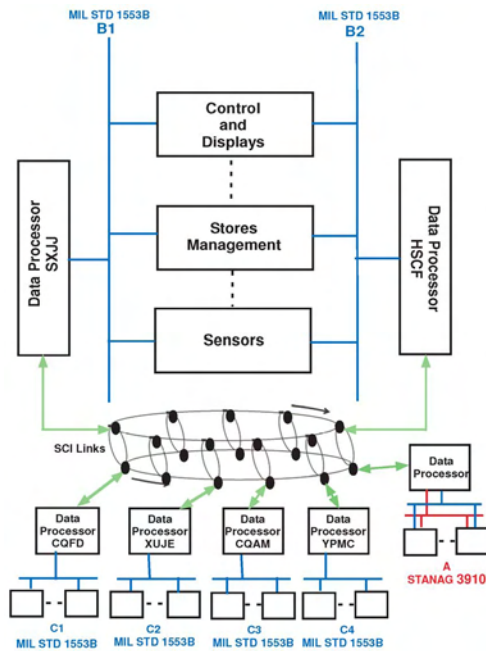

Fig. 5. A representative military aircraft network

STD 1553B buses, where the busiest one is integrated to a STANAG 3910 bus, and SCI links to assure the communication between the different 1553B Bus Controllers (figure 5).

The traffic is circulating between about twenty subsystems on each used MIL STD 1553B. Real-time traffic is described in tables I and II. So, one can see that for periodic messages, the largest period is about 160 ms and the most frequent value is 20 ms; and for aperiodic messages, there are different response time bounds and the most urgent one is about 3 ms. The transaction table of the MIL-STD 1553B bus is statically defined in such a way that time constraints are enforced and terminals are polled in a determined sequence. As a result, the major table's cycle has a duration of 160 ms and minor table's cycles 20 ms, in order to meet the requirements of the higher update rate messages. For each message, we define a deadline: for periodic messages, the deadline is the period that ranges between 20 ms and 160 ms; and for aperiodic messages their maximal response time. We suppose that a subsystem can generate at most one aperiodic message of each type once every minor frame (20 ms). Therefore, the hardest real-time constraint to respect is the maximal response time for the Hard Real Time aperiodic messages (3 ms).

TABLE I
PERIODIC TRAFFIC DESCRIPTION

Period (ms)	Number of flows	L_{max} (bytes)
20	698	130
40	60	130
80	56	130
160	630	2114

In order to integrate the above traffic in a simple manner

TABLE II
APERIODIC TRAFFIC DESCRIPTION

Response time (ms)	Number of flows	L_{max} (bytes)
3	106	84
20	420	130
160	215	130
infinity	360	2114

when replacing the current avionics network with the selected profiled Full Duplex Switched Ethernet (distributed or centralized communication scheme), a MAC address is attributed to each subsystem and the different subsystems currently connected to a MIL STD 1553B will be connected to one switch. When using the centralized scheme, the current Bus Controller on MIL STD 1553B is considered as the master. Then, communications between the different subnetworks are assured thanks to a central switch with full duplex links which replaces the current SCI links. Every 1553B message generated by a 1553B terminal is encapsulated in an Ethernet frame that respects the minimal frame size (64 bytes) and contains the source and destination addresses. Figure 6 depicts our general case study for the two communication schemes: distributed and centralized.

C. Obtained results and Comparative analysis

In our case study, given the important number of streams and the existence of multicast and broadcast transmission modes, it was more convenient to represent maximal end-to-end delay bounds related to each destination terminal than to each individual stream. Hence, the end to end delay bounds associated to each destination terminal can be calculated as the maximal end to end delay bounds among those associated to its received streams set. First, the end to end delay bounds for each traffic category received by each terminal are computed in the case of one switch. The selected switch is the busiest one among those aboard the aircraft.

In the case of Switched Ethernet with distributed communication scheme, with the FCFS policy and a capacity of 100Mbps, the end-to-end delay bounds for each stream set, characterized by a destination subsystem, are computed and the obtained results are presented in Figure 7. Clearly, one can see that for terminals SXJJ and RS end-to-end delay bounds are larger than 3 ms which means that the deadline constraint for the Hard Real Time aperiodic messages is violated. Thus, real-time constraints required by this military application would be violated, despite the relative ratio between Switched Ethernet (100Mbps) and MIL-STD 1553B (1Mbps) and the low bus utilization (6%). Hence, as opposed to some received ideas, increasing the offered bandwidth is not sufficient to have a real-time behavior with Switched Ethernet.

In order to achieve the QoS level offered by this profiled network, several service classes are required to assure a good isolation for urgent messages with hard deadline constraints. Hence, SP policy is selected here to guarantee the priority handling in data sources and in the switch. The obtained results

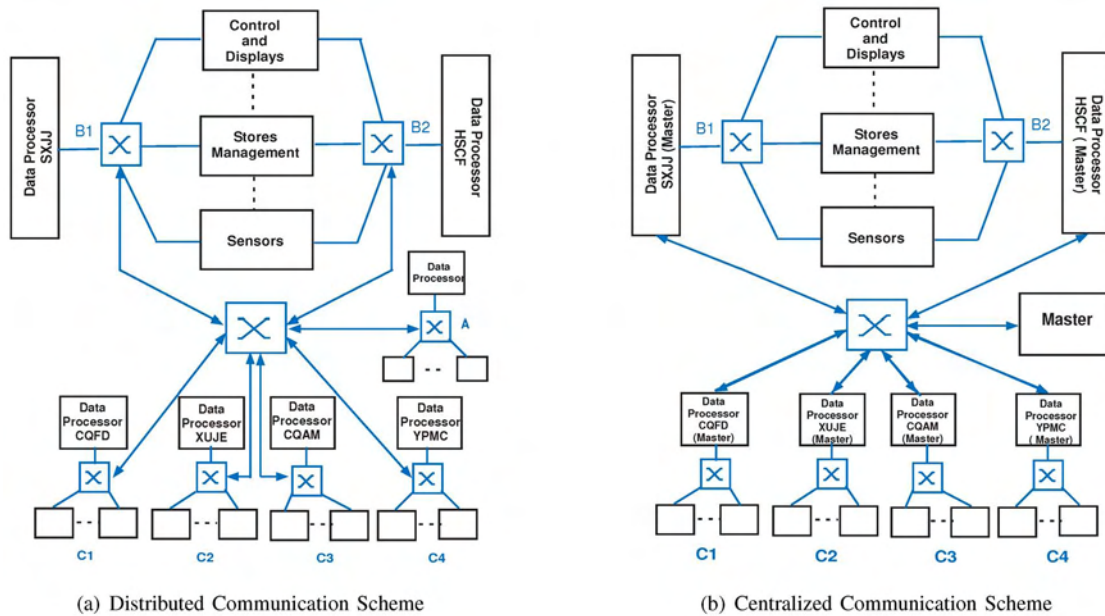

Fig. 6. Case study based on a real case of an avionic network

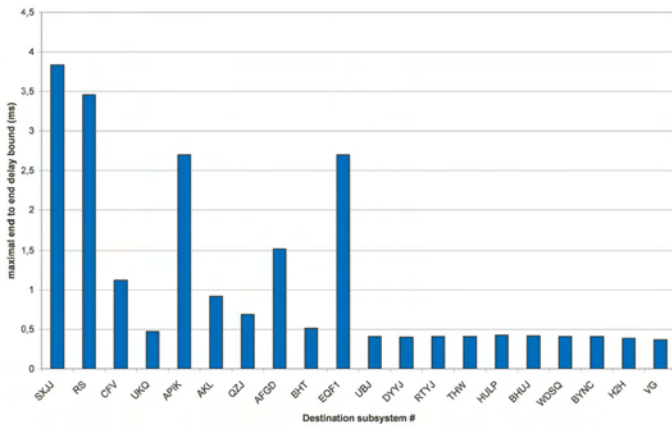

Fig. 7. Maximal end to end delay bounds with FCFS policy (distributed case)

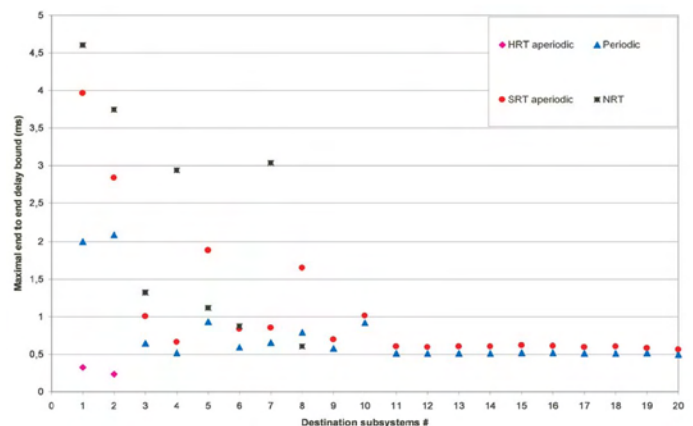

Fig. 8. Maximal end to end delay bounds with SP policy (distributed case)

are shown in figures 8. Clearly, the end to end delay bounds are inherently reduced for the HRT aperiodic traffic and satisfy the associated deadline constraint. Obviously, all delay bounds cannot improve and as a result NRT traffic delay bounds grow compared to the FCFS bounds. These results show that in the case of one switch, the QoS level required by military applications is achieved.

In the case of Switched Ethernet with a centralized communication scheme, with a 100Mbps as a capacity, optimization problem associated to FCFS policy has no admissible solution that respect all the system and temporal constraints. Whereas, the optimization problem associated to SP policy admits a feasible solution with an Elementary Cycle and a synchronous window durations about 8ms and 2ms, respectively. The optimization problem solving details are outside the scope of this paper. Maximal end to end delay bounds for each traffic

category obtained in this case for the master and the busiest slave reception port are presented in figure 9. Clearly, the delay bound for HRT aperiodic traffic satisfies the associated deadline constraint (3ms). Moreover, the periodic traffic and SRT aperiodic traffic have end to end delay bounds less than 20ms which respect the hardest deadline constraint required by these two classes. It is worth to note that delay bounds for SRT aperiodic traffic are better than periodic traffic ones, which confirms the temporal isolation between the synchronous and asynchronous windows.

Having the same capacity (100Mbps) in the case of one switch with distributed and centralized communication schemes, it is interesting to compare the obtained results. Table III shows the maximal end to end delay bounds (in milliseconds) obtained in a global manner for each traffic category (periodic, HRT aperiodic, SRT aperiodic, NRT). Clearly, one can see that the end to end delay bounds are

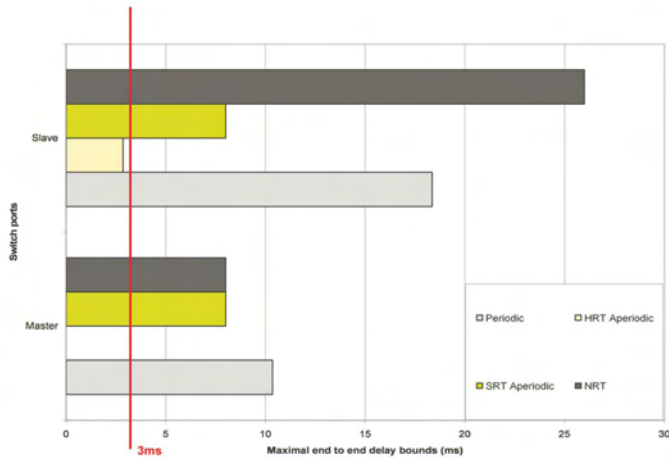

Fig. 9. Maximal end to end delay bounds obtained with SP policy (centralized case)

inherently increased for all traffic classes with the centralized communication scheme compared to the distributed one. This degradation results from the overheads imposed by the master/slave mechanism. In addition, it is worth to note that for periodic and HRT aperiodic traffic, end to end delay bounds are close to the respective deadline constraints. Thus, additional capacity could be required to guarantee a good security margin.

TABLE III
MAXIMAL END TO END DELAY BOUNDS (MILLISECONDS)

	Periodic	HRT Aperiodic	SRT Aperiodic	NRT
Distributed case	4	0, 4	2, 1	4, 6
Centralized case	18, 5	2, 7	8	26

These results show that in the case of one switch, the QoS level required by this military application is achieved. Therefore, it is interesting to generalize these results for the global avionic network. In our case study, given that the inter subnetworks communications are exclusively between Bus Controllers, it was more convenient to represent maximal end to end delay bounds related to each traffic category received by these terminals. In fact, these transmitted flows cross three switches and their related end to end delays can increase in an important manner. Hence, if these obtained delay bounds respect the associated deadline constraint, it will be the case for all transmitted flows on the network.

For the profiled Switched Ethernet with distributed communication scheme, with a 100Mbps capacity and FCFS policy, the end-to-end delay bounds for each stream set, characterized by a destination subsystem, are computed and the obtained results are presented in figure 10. Obtained end-to-end delay bounds are larger than 3 ms which means that the deadline constraint for the HRT aperiodic messages is violated. Moreover, traffic streams sent to terminals SXJJ, HSCF and CQFD have an end to end delay bound larger than 20 ms.

This value represents the smallest period for periodic flows and the response time of some aperiodic flows. Hence, the deadline constraints associated to these flows are not respected. Thus, real-time constraints required by this military application would be violated.

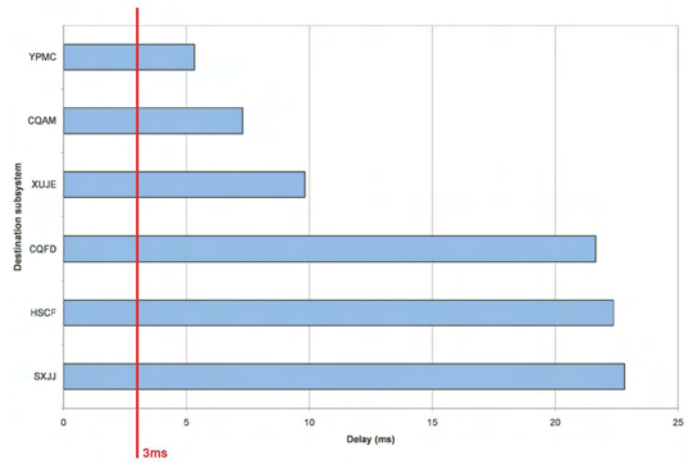

Fig. 10. Maximal end to end delay bounds obtained with FCFS policy (distributed case)

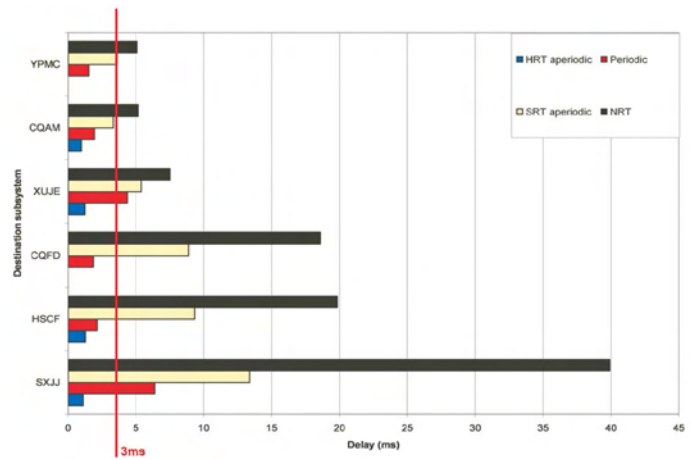

Fig. 11. Maximal end to end delay bounds obtained with SP policy (distributed case)

Hence, SP policy is selected to guarantee the priority handling and obtained results are shown in figure 11. Clearly, the end to end delay bounds are inherently reduced for HRT Aperiodic traffic and satisfy the associated deadline constraint. Moreover, for each destination subsystem, the Periodic and SRT Aperiodic traffic have end to end delay bounds less than 20 ms which respect the hardest deadline constraint required by these two classes. This amelioration is accompanied by a noticeable degradation of NRT traffic delay bounds compared to the FCFS bounds. These results show that the priority handling method combined with the traffic shaping approach may be a good mean to improve the Switched Ethernet reliability and to achieve the QoS level required by this military application.

For the profiled Switched Ethernet with centralized communication scheme, the network performances are investigated with a 100Mbps capacity. In this case, optimization problems related to FCFS and SP policies have no admissible solutions. As a result, the communication capacity is increased to 1Gbps. A feasible solution is obtained with SP policy for an Elementary Cycle and a synchronous window durations about 5ms and 1ms, respectively. The obtained results are addressed in figure 12 and we note that temporal deadlines associated to different traffic categories are respected. These results show that the proposed deterministic Master/Multi-slave Switched Ethernet satisfies the requirements of this military application.

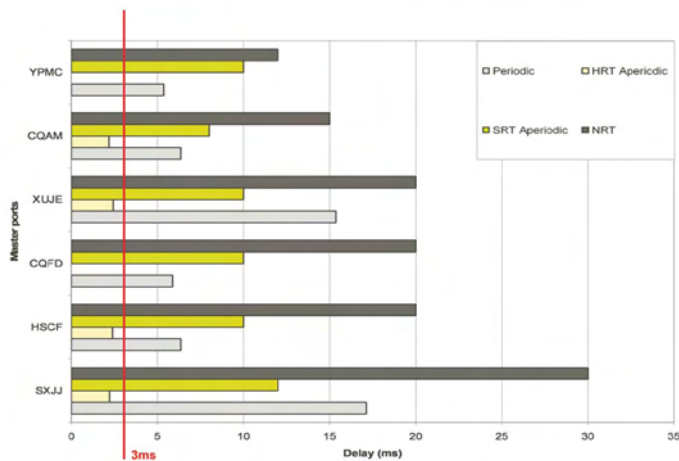

Fig. 12. Maximal end to end delay bounds with SP policy (Centralized case)

Giving obtained results for the global network with the two different communication schemes, we note that the profiled network with centralized communication scheme is more constrained than the one with distributed scheme. In fact, a larger capacity is required to satisfy the real time constraints of this military application. However, as it was said before, this communication scheme makes the migrating process to an Ethernet-compliant form easier and allows development costs reduction.

VII. CONCLUSION

We have shown, through this paper, that Full Duplex Switched Ethernet is an attractive candidate to replace the current military network in next generation applications. Our first proposal uses a distributed communication scheme where equipments can emit their data simultaneously. To guarantee an acceptable real-time behavior of this profiled network, traffic shapers were integrated in data sources to assure the traffic control. Then, a priority handling method is added to have a good isolation level for urgent messages with hard deadlines. This was achieved by using SP policy in data sources and switches. Using the *Network Calculus* theory, an analytic study was conducted to calculate deterministic guarantees offered by our proposal in the case of a realistic military aircraft network. Obtained results show the efficiency of this proposal to provide deterministic transmission with respected deadline

constraints, as required by military applications. However, migrating all existing applications in a compliant form could be an expensive step.

To overcome this limitation, the second proposal consists in keeping the current centralized communication scheme. This proposal allows: (1) an efficient aperiodic traffic handling; (2) bounded response time and real time constraints guarantees. However, this latter is more constrained than the profiled network with distributed communication scheme and needs more capacity due to the master/slave overheads.

Hence, the analytic performance evaluation a priori of these proposals allowed us to have an idea about their respective offered deterministic guarantees. Giving these obtained results, the next step will be to evaluate the practical implementation issues concerning each proposal to select the accurate network that will guarantee the real time constraints for the least amount of money.

REFERENCES

- [1] A. S. S. Committee, "Guide to avionics data buses," 1995.
- [2] M. Felsler, "Real-Time Ethernet - Industry Prospective," *Proceedings of the IEEE*, vol. 93, 2005.
- [3] J.-D. Decotignie, "Ethernet-Based Real-Time and Industrial Communications," *Proceedings of the IEEE*, vol. 93, 2005.
- [4] L. Almeida, P. Pedreiras, and J. Fonseca, "The FTT-CAN protocol: why and how," *Industrial Electronics, IEEE Transactions on*, vol. 49, 2002.
- [5] S.-K. Kweon and K. Shin, "Achieving real-time communication over Ethernet with adaptive traffic smoothing." Washington, USA: IEEE real-time technology and applications Symposium, 2000.
- [6] J. Loeser and H. Haertig, "Low latency hard real-time communication over switched Ethernet." IEEE, Proceedings of Euromicro Conference on Real-Time Systems, 2004.
- [7] J. Leboudec and P. Thiran, *Network Calculus*. Springer Verlag LNCS volume 2050, 2001.
- [8] "Ethernet Powerlink protocol home page." [Online]. Available: <http://www.ethernet-powerlink.org/>
- [9] E. technology group, "EtherCAT - Ethernet for control Automation Technology specifications." [Online]. Available: <http://www.ethercat.org/>
- [10] P. Pedreiras, P. Gai, L. Almeida, and G. C. Buttazzo, "FTT-Ethernet: A Flexible Real-Time Communication Protocol That Supports Dynamic QoS Management on Ethernet-Based Systems," *IEEE Transactions on Industrial Informatics*, vol. 1, August 2005.
- [11] R. Marau, P. Pedreiras, and L. Almeida, "Enhancing Real-time communication over COTS Ethernet switches." Proceedings of the WFCS, 2006.
- [12] M. Molle and G. Watson, "100Base-T/IEEE802.12/ Packet Switching," *IEEE Communication Magazine*, vol. 64-73, August 1996.
- [13] A. Mifdaoui, "Specification and validation of a communication network based on switched ethernet for next generation military avionics systems," Ph.D. dissertation, INP, Toulouse, 2007.
- [14] A. Mifdaoui, F. Frances, and C. Fraboul, "Full-Duplex Switched Ethernet For Next Generation "1553B"-based Applications," in *The 13th IEEE Real-Time and Embedded Technology and Applications Symposium (RTAS07)*, Bellevue, WA, United States, 2007.
- [15] —, "Real-time characteristics of Switched Ethernet for 1553B-Embedded Applications : Simulation and Analysis," in *IEEE Second International Symposium on Industrial Embedded Systems - SIES2007*, Lisbon, Portugal, 2007.