



HAL
open science

Two-Layered Oscillatory Neural Networks with Analog Feedforward Majority Gate for Image Edge Detection Application

Madeleine Abernot, Corentin Delacour, Ahmet Suna, J. Marty Gregg, Siegfried Karg, Aida Todri-Sanial

► **To cite this version:**

Madeleine Abernot, Corentin Delacour, Ahmet Suna, J. Marty Gregg, Siegfried Karg, et al.. Two-Layered Oscillatory Neural Networks with Analog Feedforward Majority Gate for Image Edge Detection Application. ISCAS 2023 - IEEE International Symposium on Circuits and Systems, May 2023, Monterey, CA, United States. pp.1-5, 10.1109/ISCAS46773.2023.10181366 . hal-04007951

HAL Id: hal-04007951

<https://hal.science/hal-04007951v1>

Submitted on 2 Mar 2023

HAL is a multi-disciplinary open access archive for the deposit and dissemination of scientific research documents, whether they are published or not. The documents may come from teaching and research institutions in France or abroad, or from public or private research centers.

L'archive ouverte pluridisciplinaire **HAL**, est destinée au dépôt et à la diffusion de documents scientifiques de niveau recherche, publiés ou non, émanant des établissements d'enseignement et de recherche français ou étrangers, des laboratoires publics ou privés.

Two-Layered Oscillatory Neural Networks with Analog Feedforward Majority Gate for Image Edge Detection Application

Madeleine Abernot¹, Corentin Delacour¹, Ahmet Suna², J. Marty Gregg², Siegfried Karg³, and Aida Todri-Saniai^{1,4}

¹LIRMM, University of Montpellier, CNRS, Montpellier, France

²School of Mathematics and Physics, Queen's University of Belfast, Belfast, United Kingdom

³Department of Science and Technology, IBM Research Europe, Zurich, Switzerland

⁴Electrical Engineering Department, Eindhoven Technical University, Eindhoven, Netherlands

Abstract— The increasing volume of smart edge devices, like smart cameras, and the growing amount of data to treat incited the development of light edge Artificial Intelligence (AI) solutions with neuromorphic computing. Oscillatory Neural Network (ONN) is a promising neuromorphic computing approach which uses networks of coupled oscillators, and their inherent parallel synchronization to compute. Also, ONN phase computing allows to limit voltage amplitude and reduce power consumption. Low-power, fast, and parallel computation properties make ONN attractive for edge AI. In state-of-the-art, ONN is built with a fully-connected architecture, with coupling defined from unsupervised learning to perform auto-associative memory tasks, like with Hopfield Networks. However, to allow ONN to solve beyond associative memory applications, there is a need to explore further ONN architectures. In this work, we propose a novel architecture of cascaded analog fully-connected ONNs interconnected with an analog feedforward majority gate layer. In particular, we show this architecture can solve image edge detection task using two fully-connected ONN layers. This is, to our best knowledge, a first analog-based solution to cascade two fully-connected ONNs.

Keywords—Oscillatory Neural Networks, Image Edge Detection, Majority Gate, Feedforward

I. INTRODUCTION

With the proliferation of edge devices in numerous domains, for example cameras for smart cities, medical assistance, and others, there is a tremendous amount of data to treat [1][2]. Artificial Intelligence (AI) with the development of Artificial Neural Networks (ANNs) is an efficient solution to solve complex problems requiring large datasets, however, it is often performed in the cloud as it requires a lot of computational resources for learning and inference [3]. Using cloud computing, data is transferred over the cloud inducing slow latency and high energy consumption. Thus, current research concentrates on how to implement AI and ANNs at the edge with limited resources and energy consumption respecting real-time constraints [4].

A solution takes inspiration from biology to design neuromorphic computing techniques, like Spiking Neural Networks [5][6]. In this work, we focus on another promising neuromorphic paradigm with Oscillatory Neural Networks (ONN) [7][8][9] inspired by brain oscillations. ONNs are networks of coupled oscillators computing with inherent parallel phase synchronisation of coupled oscillators. Phase computing encodes information in the phase relationship among oscillators. It allows to reduce power consumption by limiting the voltage amplitude. Low

power and fast parallel ONN computing makes it attractive for edge AI [10].

ONN shows efficient auto-associative memory properties with a fully-connected (FC) architecture configured with unsupervised learning [11], similar to Hopfield networks, see Fig. 1. Auto-associative memories can solve pattern recognition applications. However, to enlarge ONN application scope, it is important to explore alternative ONN architectures. Recently, [12] proposed to use ONN with a two-layer bidirectional architecture for hetero-association to perform image edge detection. Similarly, authors in [13] adapted the hetero-associative ONN from [12] to a feedforward (FF) ONN and were able to improve image edge detection performances. However, both works use digital ONN implementations on FPGA. FF-ONN is not possible with analog design due to natural bidirectional coupling among oscillators. Another approach [14] proposed a first analog multi-level ONN to perform pattern recognition, however they use frequency computing with pulse-type ONN.

In this work, we propose a novel architecture to cascade two FC-ONNs configured for pattern recognition with a FF layer based on an analog Majority Gate (MG) function. We show this architecture is also applicable to image edge detection application. To our best knowledge, it is a first attempt to cascade two analog FC-ONNs. The main contributions of this work are i) the development of a FF layer based on an analog MG function, a FF-MG layer, to connect two FC-ONNs configured for pattern recognition, and ii) the adaptation of the solution to solve image edge detection application.

The paper is organized as follows. Section II presents the ONN phase computing paradigm, and its state-of-the-art architectures and applications. Section III describes our

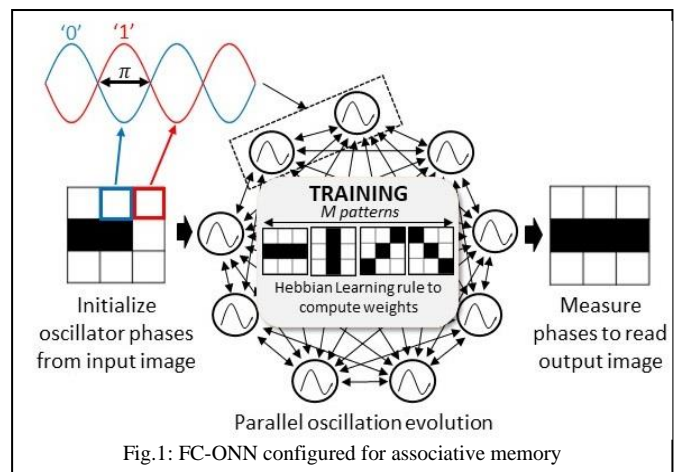

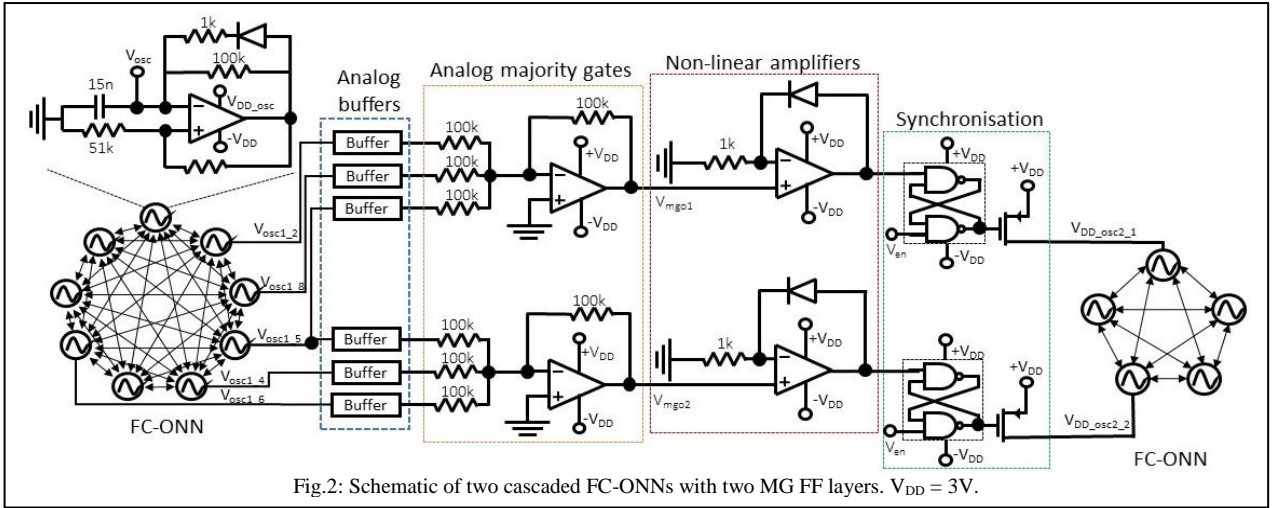

Fig.2: Schematic of two cascaded FC-ONNs with two MG FF layers. $V_{DD} = 3V$.

novel architecture using FF-MG layers to interconnect two FC-ONNs. Section IV explains how to configure the system to perform image edge detection. Section V shows results obtained of our cascaded FC-ONN architecture on the image edge detection application and compares with previous works. Finally, Section VI discusses the advantages and limitations of our FF-MG layer solution.

II. OSCILLATORY NEURAL NETWORKS (ONNS)

ONN is a neuromorphic computing paradigm taking inspiration from brain oscillations. In this Section, we present the ONN computing model and its state-of-the-art architectures and applications.

A. ONN Computing Paradigm

ONNs are networks of coupled oscillators emulating brain oscillations and using the intrinsic phase-synchronization of coupled oscillators to compute. Using phase-computing ONNs, information is encoded in the phase relationship among oscillators. For example, for binary information, a logic ‘0’ is encoded with a 0° phase, while a logic ‘1’ is encoded with a 180° phase. ONN computation starts by initializing phases of each oscillator in the network from input data. Then, phases evolve depending on the coupling between oscillators, and stabilizes to a final phase state. The evolution of phases corresponds to the minimization of an intrinsic energy parameter, like in attractor networks [15]. The final phase state gives the network output information. Thus, the coupling among oscillators, defined by learning, is the main parameter to solve specific tasks efficiently.

B. ONN Architectures and Applications

In state-of-the-art, ONN is used with a FC architecture, configured with unsupervised learning, to perform auto-associative memory tasks, like Hopfield networks, see Fig. 1. In this case, the network memorizes patterns based on its couplings and evolves to a learnt pattern when initialized with a corrupted input information. FC-ONN configured for pattern recognition can be used in various applications [16][17]. However, the FC-ONN architecture first requires large amount of coupling elements, increasing quadratically with the number of neurons. The number of synaptic elements is $N(N-1)/2$ for a network of N neurons making it hard to implement at large scale. Additionally, solving associative memory tasks is interesting but the unsupervised

learning is often limiting the network capacity, meaning the number of patterns a network can learn and retrieve efficiently. Thus, there is a need to explore other architectures and applications applicable to ONNs.

Recently, two-layer ONN architectures were introduced with bidirectional and feedforward connections between layers, considering no connections among oscillators of the same layer [12][13]. In both works, authors use their two-layer ONN to solve image edge detection. Additionally, in these works, the two-layer ONNs are implemented digitally on FPGA. However, using analog implementation, it is not possible to create a FF-ONN as coupling among oscillators is by-default bidirectional.

III. ANALOG FF-MG LAYERS FOR CASCADED FC-ONNS

In this work, we propose a solution to cascade two FC-ONNs with an analog-based FF-MG layer. Section III. A. presents the analog FC-ONN and its processing. And Section III. B. describes the analog FF-MG layer used to cascade two FC-ONNs.

A. Analog FC-ONN

In this work, we consider CMOS relaxation oscillators coupled with resistive coupling, see Fig. 2. The resistive couplings are mapped from the weights generated with unsupervised learning rules [18]. Once the coupling is configured and the circuit is mapped correctly, we initialize each oscillator. The initialization consists of applying a V_{DD_osc} to each oscillator. The phase-shift is encoded in the delay of activation of the V_{DD_osc} . For example, if we want to initialize two oscillators with 180° phase shift, we will activate V_{DD_osc1} at $t=0$, and activate V_{DD_osc2} at $t=T/2$, with T the period of oscillation. After initialization, each V_{DD_osc} stays active so oscillators’ phases evolve until stabilization. Stabilization is detected after numerous period cycles with stable phases. The final phase state corresponds to the output information of the FC-ONN.

B. Analog FF-MG layer

In this work, we propose a solution to cascade two FC-ONNs. Thus, after the first FC-ONN layer stabilization, we use the oscillating outputs as input of the FF-MG layer, as shown in Fig. 2. In Fig. 2, two FF-MG layers are represented, each layer taking as input three oscillating signals from the first FC-ONN layer, performing MG

function, and using the two FF-MG output as input of a second-layer FC-ONN.

The FF-MG layer contains various levels. A first level of analog buffers is necessary to send the first-layer FC-ONN outputs to the FF-MG layer without impacting the FC-ONN behavior. Then, the second level uses oscillations from analog buffers and performs a MG function with a summing amplifier. In Fig. 2, each MG takes three oscillating signals as input and outputs a signal with phase corresponding to the majority phase of the three input oscillations. The third level is a non-linear amplifier which saturates the signal to replicate an analog to digital conversion. From this digital signal, the fourth level synchronizes the various MG layers together. To do so, a latch is placed in between the linear amplifier output and the next-layer oscillator input. When the latch is enabled, the V_{DD_osc} of the oscillator from next layer is activated following the phase-shift given by the linear amplifier. The enable signal V_{en} is set in the same moment for each FF-MG layer to synchronize them for the next FC-ONN layer, see example in Fig. 3.

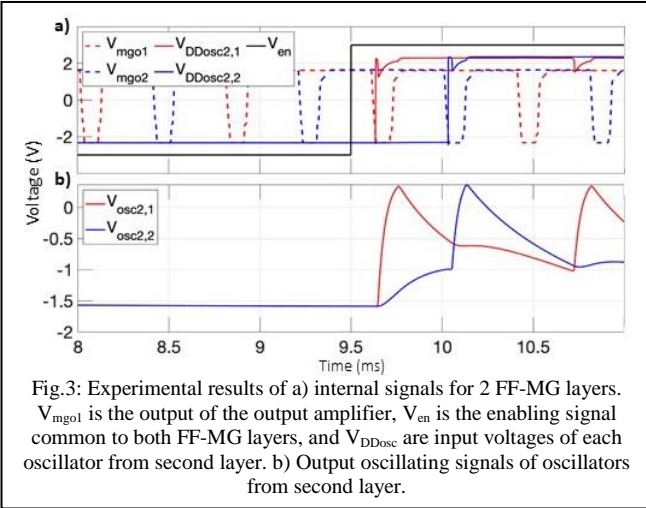

IV. APPLICATION TO IMAGE EDGE DETECTION

We apply our architecture to perform image edge detection. Image edge detection is an important image processing task used as first step of many broader problems, like image segmentation, or object detection [19][20]. Image edge detection algorithms mainly use 3x3 convolutional filters to scan an image and assign a gradient to each pixel of the image which indicates if an edge is detected. As in [12][13], we try to solve image edge detection by replacing convolutional filters with our proposed architecture. Recently, [17] proposed a solution using a FC-ONN trained to perform pattern recognition with 4 patterns representing 4 edges (horizontal, vertical, and diagonals), and using a post-processing algorithm to define if an edge is detected or not. By analyzing their solution, we noticed that the post-processing can be adapted as a combination of FF-MG layers. Thus, we propose to use our analog FF-MG solution instead of a post-processing using the same first-layer FC-ONN from [17] in order to build an analog-based all-in-one architecture. The first FC-ONN is trained with 4 patterns representing the 4 main edges (horizontal, vertical, and diagonals), using the Hebbian learning rule [21] see Fig. 4.a). Then, when the first FC-ONN is stable, we use its output as input of 4 FF-MG layers to detect each edge, see Fig. 4.b).

Note, the second-layer FC-ONN does not have any connections between oscillators. It can be considered as a FC-ONN with 0-weights coupling. We test and validate our solution with a hardware board for two edges, horizontal and vertical, and we generalize for four edges using simulations.

V. RESULTS

This section presents results of our analog-based FF-MG architecture to cascade two FC-ONN adapted to image edge detection. Fig. 5 shows results of our image edge detection solution on the ‘cameraman’ large scale image. Visually, it shows that we can detect edges efficiently. It is compared with a digital FF-ONN applicable for image edge detection using an FPGA implementation [13]. The digital FF-ONN

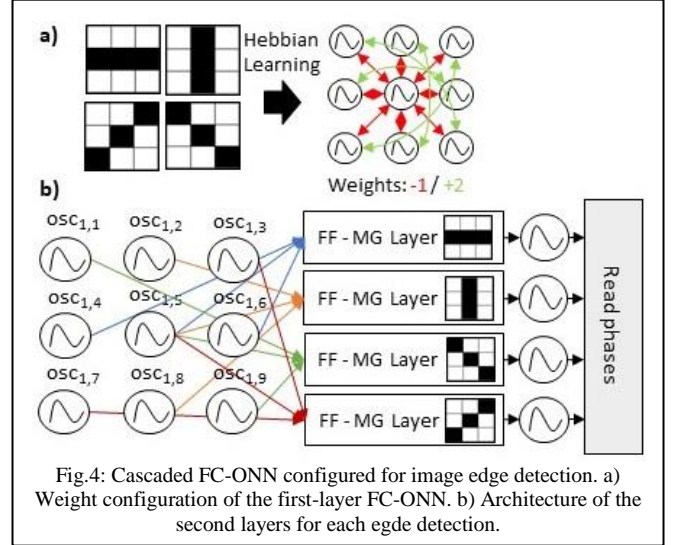

does not cascade two FC-ONN but considers an input layer that feeds an output layer without connections among neurons in the same layer. Table I shows the Jaccard Similarity Coefficient (JSC) metric that uses the state-of-the-art Canny algorithm [22] as ground truth (GT), and is compared with the state-of-the-art Sobel algorithm [23], as well as the digital FF-ONN [13]. Table I shows that the two cascaded analog FC-ONN using a FF-MG layer miss some important edges, and does not place correctly all detected edges.

Another, important parameter for image edge detection algorithm is the latency. In order to compare the FF-ONN [13] solution meaningfully with our analog FC-ONN, we reproduce our analog system in digital. To do so, we use a digital FC-ONN configured for pattern recognition of the four edge patterns, see Fig. 4.a). And we connect four FF-ONNs with weights equal to 1 to replace the analog FF-MG layer. The digital FF-ONN with weights equal to ‘1’ reproduces the MG function. Both analog and digital systems obtain the same precision results. Table II reports on latency of our solution (analog and digital implementation) compared to digital FF-ONN from [13]. The analog FC-ONN stabilizes in 4-5 oscillation cycles while the digital FC-ONN only requires 3-4 cycles. On the other side, the digital FF-ONN, and the analog FF-MG layers stabilize in only 1 to 2 cycles. Thus, the cascaded FC-ONNs solution requires the stabilization of a FC-ONN and a MG layer, whereas the FF-ONN only requires to wait for the digital FF-ONN stabilization, hence the latency of our solution is longer. Note, we consider a parallel execution of the four MG layers

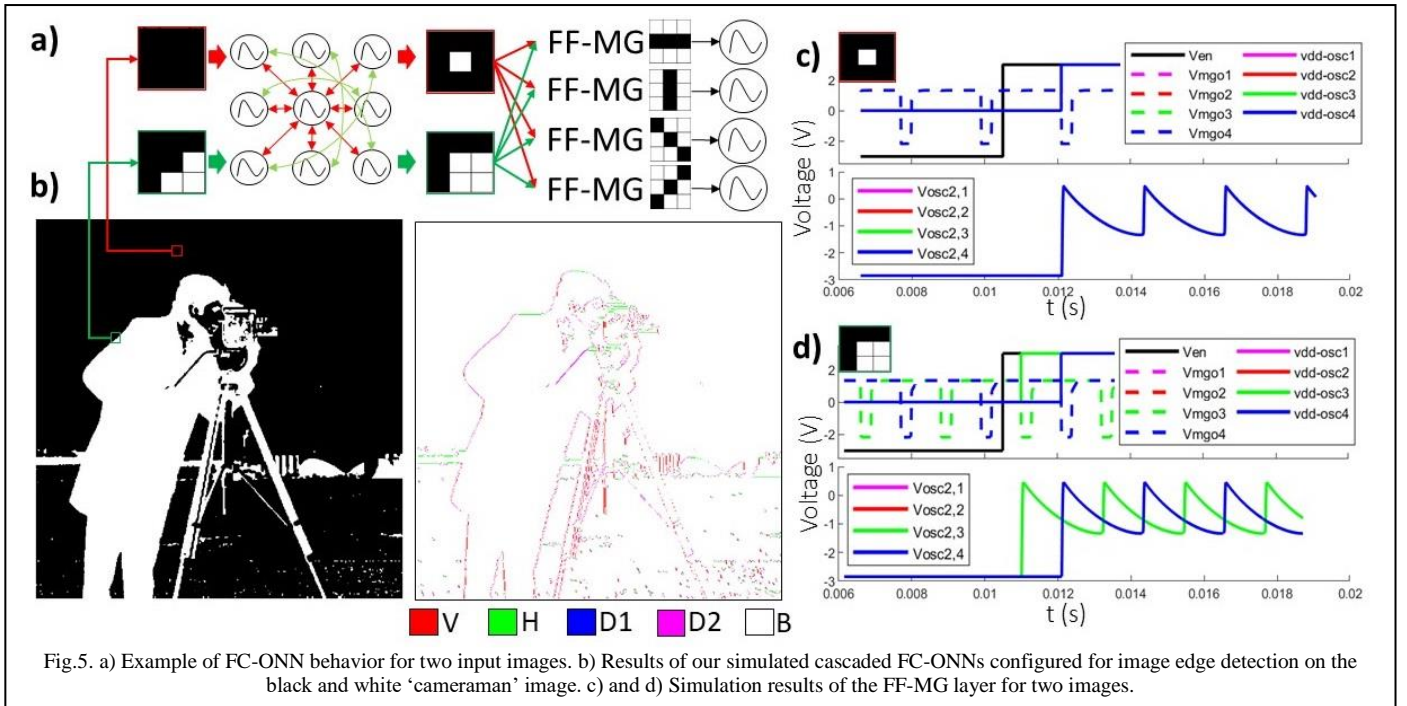

Fig.5. a) Example of FC-ONN behavior for two input images. b) Results of our simulated cascaded FC-ONNs configured for image edge detection on the black and white ‘cameraman’ image. c) and d) Simulation results of the FF-MG layer for two images.

to speed up the process and the oscillating frequency is higher in analog than in digital.

This work proposes an analog solution to cascade two FC-ONN using a MG activation function, and shows it can solve image edge detection task, even though it has limited precision, and longer processing time.

TABLE I: PRECISION OF CASCADED ANALOG FC-ONNS ON IMAGE EDGE DETECTION ON THE ‘CAMERAMAN’ IMAGE COMPARED WITH CANNY GROUND TRUTH (GT)

GT: Canny	Sobel	Dig. FF-ONN [13]	This work
JSC	0.5204	0.4388	0.1866
Overlapping	7277	7433	2021
Union	13983	16941	10832

TABLE II: LATENCY OF OUR SOLUTION COMPARED TO PREVIOUS DIGITAL FF-ONN [13], AND ESTIMATION FOR LARGE-SCALE IMAGES.

Latency	Digital FF-ONN [13]	This work – analog $F_a=3$ MHz	This work – digital $F_a=2.7$ MHz
3x3	1.15 us	FC: 1.67 us FF-MG: 0.67 us	FC: 1.42 us FF: 1.15 us
28x28	0.78 ms	1.83 ms	2.01 ms
512x512	301 ms	613 ms	674 ms

VI. DISCUSSION

This work introduces an analog-based architecture to cascade two analog FC-ONNs using a FF-MG activation function. We show this novel architecture is capable of performing image edge detection task. However, it is less precise, detects less edges with higher latency than previous FF-ONN work.

Nevertheless, this work introduces a novel FC-ONN layered architecture which can allow ONN to explore novel applications. The proposed architecture is modular; thus, it can be adapted to include more than two FC-ONN layers, with modularity in input and output data. Furthermore, in this paper, we only consider an analog MG activation function. However, we can replace the FF-MG with other activations. For example, in [24][25], authors have shown MG functions to construct different operations such as AND, OR, and

XOR. Even though we applied our architecture to image edge detection as commonly explored in the state-of-the-art [17], however, applying FF-MG layers, it is, in principle, compatible with numerous applications requiring at least two FC-ONN layers. However, it requires further investigations to train such a system for a specific task.

Finally, the FF-MG layer is almost fully analog, apart from the digital latch level. Using a fully-analog system is advantageous for analog computing applications, for example for smart sensors. In our design, the latch takes care of the synchronization of the different FF-MG layers. Also, it limits the power consumption by activating the second FC-ONN layer once the first FC-ONN layer is over. However, note that if all FF-MG inputs are synchronized, for example if they are part of the same FC-ONN, then input signals to second FC-ONN should also be synchronized. Thus, our FF-MG layer can adapt to a fully-analog system.

VII. CONCLUSION

This paper presents a first solution to cascade analog fully-connected ONNs with an analog feedforward majority gate layer. This is, to the best of our knowledge, a first attempt to achieve analog feedforward ONN by cascading two fully-connected ONNs. More particularly, we use an analog feedforward majority gate layer to connect two fully-connected ONNs. We show this novel architecture can be adapted to perform image edge detection. In this case, a first-layer fully-connected ONN is trained for pattern recognition with four 3x3 images representing edges (horizontal, vertical, and diagonals). Then, four feedforward majority gate layers are used to post-process the output of the first fully-connected ONN and detect edges. Even though performances are not competitive compared with state-of-the-art edge detection algorithms, our novel modular architecture based on cascaded fully-connected ONNs enlarges the scope of analog ONN applications.

ACKNOWLEDGMENT

Empty for blind review.

REFERENCES

- [1] D. Luckey, H. Fritz, D. Legatiuk, K. Dragos, et K. Smarsly, « Artificial Intelligence Techniques for Smart City Applications », in Proceedings of the 18th International Conference on Computing in Civil and Building Engineering, 2021, doi: 10.1007/978-3-030-51295-8_1.
- [2] R. Baran, T. Rusc, et P. Fornalski, « A smart camera for the surveillance of vehicles in intelligent transportation systems », *Multimed. Tools Appl.*, 2016, doi: 10.1007/s11042-015-3151-y.
- [3] L. Sun, X. Jiang, H. Ren, et Y. Guo, « Edge-Cloud Computing and Artificial Intelligence in Internet of Medical Things: Architecture, Technology and Application », *IEEE Access*, 2020, doi: 10.1109/ACCESS.2020.2997831.
- [4] G. Plastiras, M. Terzi, C. Kyrkou, et T. Theocharidis, « Edge Intelligence: Challenges and Opportunities of Near-Sensor Machine Learning Applications », in 2018 IEEE 29th International Conference on Application-specific Systems, Architectures and Processors (ASAP), 2018, doi: 10.1109/ASAP.2018.8445118.
- [5] C. D. Schuman, S. R. Kulkarni, M. Parsa, J. P. Mitchell, P. Date, et B. Kay, « Opportunities for neuromorphic computing algorithms and applications », *Nat. Comput. Sci.*, 2022, doi: 10.1038/s43588-021-00184-y.
- [6] D. V. Christensen et al., « 2022 roadmap on neuromorphic computing and engineering », *Neuromorphic Comput. Eng.*, 2022, doi: 10.1088/2634-4386/ac4a83.
- [7] G. Csaba et W. Porod, « Coupled oscillators for computing: A review and perspective », *Appl. Phys. Rev.*, 2020, doi: 10.1063/1.5120412.
- [8] D. E. Nikonov et I. A. Young, « Benchmarking Delay and Energy of Neural Inference Circuits », *IEEE J. Explor. Solid-State Comput. Devices Circuits*, 2019, doi: 10.1109/JXCDC.2019.2956112.
- [9] A. Todri-Sanial et al., « How Frequency Injection Locking Can Train Oscillatory Neural Networks to Compute in Phase », *IEEE Trans. Neural Netw. Learn. Syst.*, 2021, doi: 10.1109/TNNLS.2021.3107771.
- [10] C. Delacour, S. Carapezzi, M. Abernot, et A. Todri-Sanial, « Energy-Performance Assessment of Oscillatory Neural Networks based on VO₂ Devices for Future Edge AI Computing », 2022, doi: 10.36227/techrxiv.19248446.v1.
- [11] F. C. Hoppensteadt et E. M. Izhikevich, « Pattern recognition via synchronization in phase-locked loop neural networks », *IEEE Trans. Neural Netw.*, 2000, doi: 10.1109/72.846744.
- [12] Empty for blind review.
- [13] Empty for blind review.
- [14] A. Velichko, M. Belyaev, et P. Boriskov, « A Model of an Oscillatory Neural Network with Multilevel Neurons for Pattern Recognition and Computing », *Electronics*, 2019, doi: 10.3390/electronics8010075.
- [15] J. Buhmann, R. Divko, et K. Schulten, « Associative memory with high information content », *Phys. Rev. A*, 1989, doi: 10.1103/PhysRevA.39.2689.
- [16] M. Abernot et al., « Oscillatory Neural Networks for Obstacle Avoidance on Mobile Surveillance Robot E4 », in 2022 International Joint Conference on Neural Networks (IJCNN), 2022, doi: 10.1109/IJCNN55064.2022.9891923.
- [17] Empty for blind review.
- [18] C. Delacour et A. Todri-Sanial, « Mapping Hebbian Learning Rules to Coupling Resistances for Oscillatory Neural Networks », *Front. Neurosci.*, 2021, doi: 10.3389/fnins.2021.694549.
- [19] D. G. Lowe, « Object recognition from local scale-invariant features », in Proceedings of the Seventh IEEE International Conference on Computer Vision, 1999, doi: 10.1109/ICCV.1999.790410.
- [20] A. De et C. Guo, « An image segmentation method based on the fusion of vector quantization and edge detection with applications to medical image processing », *Int. J. Mach. Learn. Cybern.*, 2014, doi: 10.1007/s13042-013-0205-1.
- [21] R. G. M. Morris, « D.O. Hebb: The Organization of Behavior, Wiley: New York; 1949 », *Brain Res. Bull.*, 1999, doi: 10.1016/S0361-9230(99)00182-3.
- [22] J. Canny, « A Computational Approach to Edge Detection », *IEEE Trans. Pattern Anal. Mach. Intell.*, 1986, doi: 10.1109/TPAMI.1986.4767851.
- [23] I. Sobel et G. Feldman, « A 3×3 isotropic gradient operator for image processing », *Pattern Classif. Scene Anal.*, 1973.
- [24] S. Amarel, G. Cooke, et R. O. Winder, « Majority Gate Networks », *IEEE Trans. Electron. Comput.*, 1964, doi: 10.1109/PGEC.1964.263829.
- [25] E. Goto, « The Parametron, a Digital Computing Element Which Utilizes Parametric Oscillation », *Proc. IRE*, 1959, doi: 10.1109/JRPROC.1959.287195.