



**HAL**  
open science

# **CNR-IEMN-CD and CNR-IEMN-CSD Approaches for Covid-19 Detection and Covid-19 Severity Detection from 3D CT-scans**

Fares Bougourzi, Cosimo Distanto, Fadi Dornaika, Abdelmalik Taleb-Ahmed

► **To cite this version:**

Fares Bougourzi, Cosimo Distanto, Fadi Dornaika, Abdelmalik Taleb-Ahmed. CNR-IEMN-CD and CNR-IEMN-CSD Approaches for Covid-19 Detection and Covid-19 Severity Detection from 3D CT-scans. European Conference on Computer Vision, ECCV 2022 Workshops, Oct 2022, Tel Aviv, Israel. pp.593-604, 10.1007/978-3-031-25082-8\_40 . hal-03996583

**HAL Id: hal-03996583**

**<https://hal.science/hal-03996583>**

Submitted on 20 Feb 2023

**HAL** is a multi-disciplinary open access archive for the deposit and dissemination of scientific research documents, whether they are published or not. The documents may come from teaching and research institutions in France or abroad, or from public or private research centers.

L'archive ouverte pluridisciplinaire **HAL**, est destinée au dépôt et à la diffusion de documents scientifiques de niveau recherche, publiés ou non, émanant des établissements d'enseignement et de recherche français ou étrangers, des laboratoires publics ou privés.

# CNR-IEMN-CD and CNR-IEMN-CSD approaches for Covid-19 Detection and Covid-19 Severity Detection From 3D CT-scans

Fares Bougourzi<sup>\*,1</sup>[0000-0001-5077-4862], Cosimo Distanto<sup>1</sup>[0000-0002-1073-2390],  
Fadi Dornaika<sup>2,3</sup>[0000-0001-9092-735X], and Abdelmalik  
Taleb-Ahmed<sup>4</sup>[0000-0001-8750-1905]

<sup>1</sup> Institute of Applied Sciences and Intelligent Systems, National Research Council of Italy, 73100 Lecce, Italy; [fares.bougourzi@isasi.cnr.it](mailto:fares.bougourzi@isasi.cnr.it); [cosimo.distanto@cnr.it](mailto:cosimo.distanto@cnr.it)

<sup>2</sup> University of the Basque Country UPV/EHU, San Sebastian, Spain

<sup>3</sup> IKERBASQUE, Basque Foundation for Science, Bilbao, Spain  
[fadi.dornaika@ehu.eus](mailto:fadi.dornaika@ehu.eus)

<sup>4</sup> Univ. Polytechnique Hauts-de-France, Univ. Lille, CNRS, Centrale Lille, UMR 8520 - IEMN, F-59313 Valenciennes, France; [Abdelmalik.Taleb-Ahmed@uphf.fr](mailto:Abdelmalik.Taleb-Ahmed@uphf.fr)

\* Corresponding Author

**Abstract.** Since its appearance in late 2019, Covid-19 has become an active research topic for the artificial intelligence (AI) community. One of the most interesting AI topics is Covid-19 analysis from medical imaging. CT-scan imaging is the most informative tool about this disease.

This work is part of the 2nd COV19D competition, where two challenges are set: Covid-19 Detection and Covid-19 Severity Detection from the CT-scans. For Covid-19 detection from CT-scans, we proposed an ensemble of 2D Convolution blocks with Densenet-161 models (CNR-IEMN-CD). Here, each 2D convolutional block with Densenet-161 architecture is trained separately and in the testing phase, the ensemble model is based on the average of their probabilities. On the other hand, we proposed an ensemble of Convolutional Layers with Inception models for Covid-19 severity detection CNR-IEMN-CSD. In addition to the Convolutional Layers, three Inception variants were used, namely Inception-v3, Inception-v4 and Inception-Resnet.

Our proposed approaches outperformed the baseline approach in the validation data of the 2nd COV19D competition by 11% and 16% for Covid-19 detection and Covid-19 severity detection, respectively. In the testing phase, our proposed approach CNR-IEMN-CD ranked fifth and improved the baseline results by 18.37%. On the other hand, our proposed approach CNR-IEMN-CSD ranked third in the test data of the 2nd COV19D competition for Covid-19 severity detection, and improved the baseline results by 6.81%.

**Keywords:** Covid-19, Deep Learning, CNNs, Recognition, Severity

## 1 Introduction

Since the appearance of the Covid-19 pandemic in the late of 2019, reverse transcription-polymerase chain reaction (RT-PCR) has been considered as the golden standards for Covid-19 Detection. However, the RT-PCR test has many drawbacks including inadequate supply of RT-PCR kits, time-consuming consumption, and considerable false negative results [9] [23] [15]. To overcome these limitations, medical imaging techniques have been widely used as tools. These imaging techniques include X-rays and CT-scans [22] [5]. In fact, CT-scans are not only used to detect Covid-19 infected cases, but they could also be used to track the patient’s condition and predict the severity of the disease [7] [4].

In the last decade, Deep Learning methods have become widely used in most computer vision tasks and have achieved high performance compared to traditional methods [2] [3]. However, the main drawback of Deep Learning, especially the CNN architecture, is the need for huge labeled data, which is difficult to obtain in medical fields [7]. On the other hand, most of the proposed CNN architectures have been used for static images (single image input) [4].

In this work, we used pre-trained CNN architectures to detect Covid-19 infection and Covid-19 severity from 3D CT scans in the context of the 2nd COV19D challenge. We also trained a CNN model to filter out the sections that do not show a lung region. For Covid-19 severity detection, an Att-Unet model was trained to segment the lung regions and remove unimportant features. In addition, two volume input branches were used to reduce information loss due to resizing and varying the number of slices from one CT-scan to another. The main contributions of this work can be summarized as follows:

- For Covid-19 detection from CT scans, we proposed an ensemble of Convolution 2D blocks with Densenet-161 models, which we call CNR-IEMN-CD. Each convolution 2D block with densenet-161 architecture was trained separately, and the ensemble model is based on the average of their probabilities.
- To detect the severity of Covid-19 using CT scans, we proposed an ensemble of Convolutional Layer with Inception models, which we call CNR-IEMN-CSD. In addition to the Convolutional Layers, three Inception variants were used, namely Inception-v3, Inception-v4, and Inception-Resnet. The Inception variants were trained twice separately and the ensemble model is the average of the probabilities of the six models.
- Our proposed approaches outperformed the baseline approach in the validation data of the 2nd COV19D competition by 11% and 16% in Covid-19 detection and Covid-19 severity detection, respectively. Moreover, our proposed approach CNR-IEMN-CD ranked fifth and improved the results of the baseline approach by 18.37%. On the other hand, our proposed approach CNR-IEMN-CSD ranked third in the test data of the 2nd COV19D competition for Covid-19 severity detection and improved the baseline results by 6.81%.
- The codes used are publicly available at <https://github.com/faresbougourzi/2nd-COV19D-Competition>. (Last accessed 28<sup>th</sup> June 2022).

This paper is organized as follows: Section 2 describes our proposed approaches for Covid-19 detection and severity detection. The experiments and results are described in Section 3. In Section 4, the obtained results of Covid-19 Detection Challenge are discussed. Finally, we conclude our paper in Section 5.

## 2 Our Approaches

In the following two sections, we will describe our proposed approaches for Covid-19 detection and severity prediction, respectively.

### 2.1 Covid-19 Detection

Our proposed approach to Covid-19 detection for the 2nd COV19D competition is summarized in Figure 1. Because the 3D CT scans have a different number of layers depending on the scanner and acquisition settings and contain multiple slices with no lung regions, we trained a model to remove the non-lung slices. For this purpose, we manually labelled 20 CT-scans from the training data as lung and non-lung. In addition, we used the following datasets: COVID-19 CT segmentation [19], Segmentation dataset nr.2 [19], and COVID-19- CT Seg dataset [16] to have more labelled data as lung and non-lung slices. After creating the lung and non-lung sets, we trained the ResneXt-50 model [24] to remove the slices that showed no lungs at all. Since the CT scans have different numbers of slices, we concatenated all lung slices and then reduced them to  $224 \times 224 \times 64$  as shown in Figure 1. To distinguish between Covid-19 and non-Covid-19 CT scans, we separately trained three Densenet-161 [8] models. Since the input size of the Densenet-161 model is an RGB image and we have a 3D volume of size  $224 \times 224 \times 64$ , we added Convolution block with a  $3 \times 3$  kernel, a stride of 1, and a padding of 1. The  $3 \times 3$  convolution block takes 64 input channels and produces 3 output channels. It should be noted that each CNN model was trained separately. In the decision or test phase, we propose to form an ensemble of the three trained CNN architectures by averaging their probabilities.

### 2.2 Covid-19 Severity Detection

Our proposed approach to predict Covid-19 severity for the 2nd COV19D competition is summarized in Figure 2. Similar to the Covid-19 detection in section 2.1, we used the trained ResneXt-50 model to remove non-lung slices. To segment the lungs, we used the Att-Unet [17] [6] architecture trained with the following datasets COVID-19 CT segmentation [19], Segmentation dataset nr.2 [19], and COVID-19-CT-Seg [16]. After removing the non-lung slices and segmenting the lung regions to remove unnecessary features, we divided generated for each scan, from the obtained slices, two volumes  $299 \times 299 \times 32$  and  $299 \times 299 \times 16$ . The goal of the two volumes is to reduce the information lost due to resizing and to obtain two views of each CT scan. The two input volumes were fed into

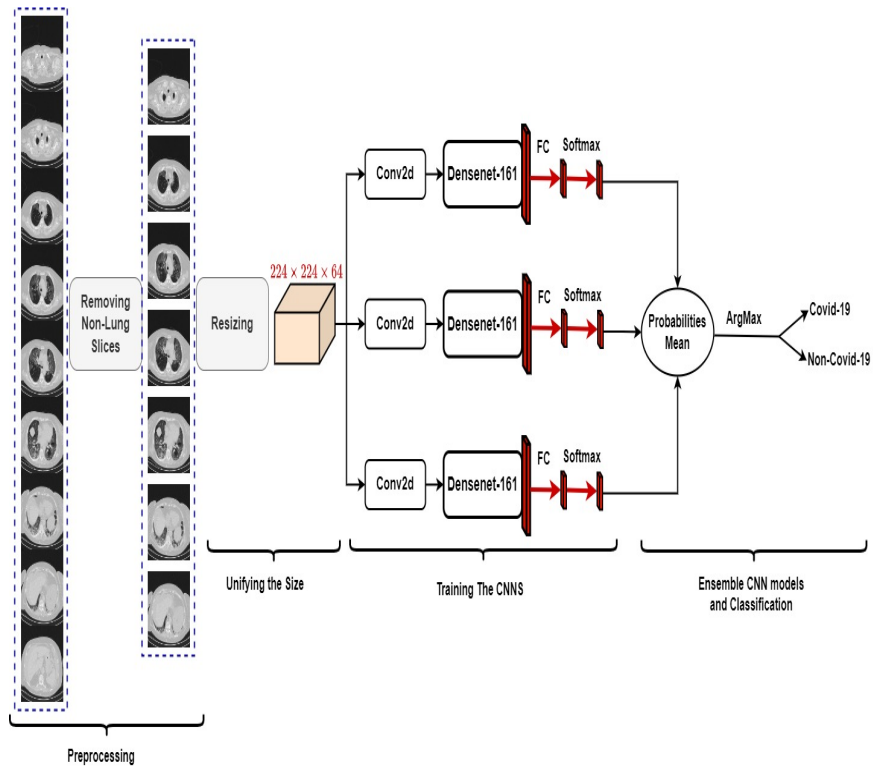

Fig. 1: Our proposed CNR-IEMN-CD Approach for Covid-19 Detection.

convolution blocks. The convolution layer consists of three  $3 \times 3$  convolution blocks with stride 1 and padding 1 (see Figure 2). The first convolution block transforms the volume  $299 \times 299 \times 32$  into  $299 \times 299 \times 3$ . Similarly, the second convolution block transforms the volume  $299 \times 299 \times 16$  into  $299 \times 299 \times 3$ . The third convolution block transforms the concatenation of the outputs of the first and second convolution blocks ( $299 \times 299 \times 3$ ) into  $299 \times 299 \times 3$ . The output volume of the third convolution block is used as input to a CNN backbone. In our experiments, we used Inception architectures as CNN backbones, namely, inception-V3, inception-V4, and Inception-Resnet [21]. Our approach to predict the severity of Covid-19 consists of six ConvLayers + CNN branches, as shown in Figure 2, where each branch was trained separately. To create a more comprehensive ensemble model, we trained each CNN model twice. The final prediction of Covid-19 severity was obtained by averaging the prediction probabilities of the six models.

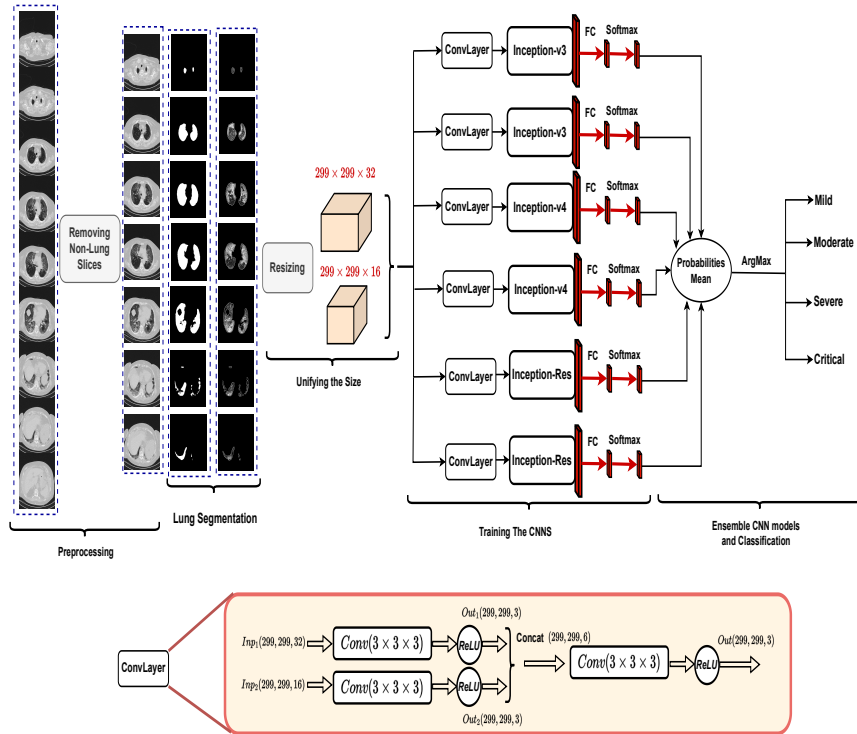

Fig. 2: Our proposed CNR-IEMN-CSD approach for Covid-19 Severity Detection.

### 3 Experiments and Results

#### 3.1 The COV19-CT-DB Database

The COVID19-CT-Database (COV19-CT-DB) [10] [11] [12] [14] [13] [1] consists of chest CT scans that are annotated for the existence of COVID-19.

Table 1: Data samples in each Set.

Set	Training	Validation
Covid-19	882	215
Non-Covid-19	1110	289

Table 2: Data samples in each Severity Class

Severity Class	Training	Validation
1	85	22
2	62	10
3	85	22
4	26	5

COVID19-CT-DB contains 3-D CT scans of the chest, which have been examined for the presence of COVID-19. Each of the 3-D scans contains a different number of slices, ranging from 50 to 700. The database was divided into a training set, a validation set, and a test set. The training set contains a total of 1992 3-D CT scans. The validation set consists of 494 3-D CT scans. The number of COVID-19 and non COVID-19 cases in each set is given in Table 1.

Further subdivision of the COVID-19 cases was based on the severity of COVID-19, which was given by four medical experts in a range of 1 to 4, with 4 denoting the critical state. The training set contains a total of 258 3-D scans CT. The validation set consists of 61 3-D CT scans. The number of scans in each severity class in these sets is shown in Table 2.

#### 3.2 Experimental Setup

For Deep Learning training and testing, we used the Pytorch [18] Library with NVIDIA GPU Device GeForce TITAN RTX 24 GB. The batch size used consists of 16 CT-scan volumes for both tasks. We trained the networks for 40 epochs. The initial learning rate is 0.0001, which decreases by 0.1 after 15 epochs, followed by another 0.1 decrease after 30 epochs.

### 3.3 Covid-19 Recognition

Table 3 summarizes the Covid-19 detection results (F1 score) obtained with the validation data. As described in section 2.1, we trained three Convolutional Block + Densenet-161 architectures. For simplicity, we refer to Convolutional Block + Densenet-161 with Densenet-161 and the training iteration. This table shows the results of the individual Densenet-161 models and the ensemble of 2 and three models. The ensemble of three models is denoted by (CNR-IEMN-CD). From these results, the ensemble of two models achieves better results than the individual models. The ensemble of three models, on the other hand, achieves the best performance. Compared to the baseline results, our proposal CNR-IEMN-CD improved the results by 13%.

Table 3: Covid-19 Detection Results on the 2nd COV19D competition validation data.

Model	Architecture	F1-Score
-	Baseline	77
1	Densenet-161 Model1	88.34
2	Densenet-161 Model2	88.83
3	Densenet-161 Model3	87.81
4	Ensemble (1&2)	89.61
5	Ensemble (2&3)	89.85
6	Ensemble (1&2&3)	90.07

Since five submissions were allowed in the 2nd COV19D competition, our submissions are 1, 2, 4, 5 and 6. The obtained results are summarized in Table 4. From these results, we notice that the ensemble of the three Densenet-161 models achieved the best performance than using single models and the ensemble of two models as well. Furthermore, our approach achieved higher performance than the baseline method by 18.37%. On the other hand, our approach ranked the fifth in the 2nd COV19D competition for Covid-19 Detection.

Table 4: Covid-19 Detection Results on the 2nd COV19D competition testing data.

Model	Architecture	F1-Score
-	Baseline	66.00
1	Densenet-161 Model1	81.91
2	Densenet-161 Model2	77.03
4	Ensemble (1&2)	83.12
5	Ensemble (2&3)	84.12
6	Ensemble (1&2&3)	84.37



### 3.4 Covid-19 Severity Detection

Table 5 summarizes the results (F1 score) of detecting the severity of Covid-19 using the validation data. As described in section 2.2, we designed three models consisting of convolutional layers and CNN backbones. The CNN backbones used are Inception-V3, Inception-V4, and Inception-Resnet, and each model was trained twice to obtain a greater variety of predictors. In total, we have six models. For simplicity, we refer to ConvLayer + CNN backbone with the backbone architecture name. Table 5 shows the obtained results of the individual models and the ensemble of two models of the same architecture and the ensemble of the six models (CNR-IEMN-CSD). The obtained results show that the ensemble of two models improves the performance compared to the single models. Moreover, the ensemble of the six models achieved the best performance and was 17% better than the baseline.

Table 5: Covid-19 Severity Detection Results on the 2nd COV19D Severity Detection competition validation data.

Model	Architecture	F1-Score
-	Baseline	63.00
1	Inception-v3 Model1	74.86
2	Inception-v3 Model2	76.25
3	Inception-v4 Model1	75.60
4	Inception-v4 Model2	73.48
5	Inception-Res Model1	73.37
6	Inception-Res Model2	72.01
7	Ensemble Models(1-2)	79.10
8	Ensemble Models(3-4)	79.54
9	Ensemble Models(5-6)	79.10
10	Ensemble Models(1-6)	80.08

Since five submissions were allowed in the 2nd COV19D competition, our submissions are 1, 7, 8, 9 and 10. The obtained results on the testing data of the 2nd COV19D Severity Detection competition are summarized in Table 6. From these results, we notice our proposed CNR-IEMN-CSD approach achieved the best performance than using single models and the ensemble of two models as well. Furthermore, our approach achieved higher performance than the baseline method by 6.8%. On the other hand, our approach ranked the fifth in the 2nd COV19D competition.

## 4 Discussion

To understand the behavior of our proposed approach for Covid-19 detection challenge, we visualize some slices from predicted CT-scans as TP, TN, FP, FN as shown in Figure 3. As stated in [20], the COVID-19 lung imaging manifestations

Table 6: Covid-19 Severity Detection Results on the 2nd COV19D Severity Detection competition Testing data.

Model	Architecture	F1-Score	Mild	Moderate	Severe	Critical
-	Baseline	40.30	61.10	39.47	37.07	23.54
2	Inception-v3 Model2	39.89	34.86	35.44	58.00	31.25
7	Ensemble Models(1-2)	43.04	53.09	18.52	63.52	37.04
8	Ensemble Models(3-4)	45.49	54.66	26.79	63.48	37.04
9	Ensemble Models(5-6)	44.37	53.42	26.67	60.36	37.04
10	Ensemble Models(1-6)	47.11	55.67	37.88	55.46	39.46

are highly overlapped with those of the viral pneumonia and this makes the diagnosis of Covid-19 challenging even for the radiologists. It can be noticed that in the 2nd COV19D competition for Covid-19 Detection, only two classes were defined, Covid-19 and Non-Covid. Thus, that Non-Covid class may presents No infection at all or other lung diseases.

The first row shows that many Non-Covid cases are classified as Covid-19, these examples shows the appearance of infection manifestations, however, the signs are not related to Covid-19 infection. The second row shows similar infection signs and the CT-scans were correctly classified as Covid-19. From the third row shows that our approach can misclassify when the Covid-19 infection appears in small region of the lungs. The fourth row shows that our approach is able to classify Non-Covid CT-scans despite the appearance of the infection signs of the other diseases. Especially, with using the ensemble of multiple models. From these examples, we argue that separating other diseases as separate class can help the trained models to distinguish between the Covid-19 and Non-Covid cases.

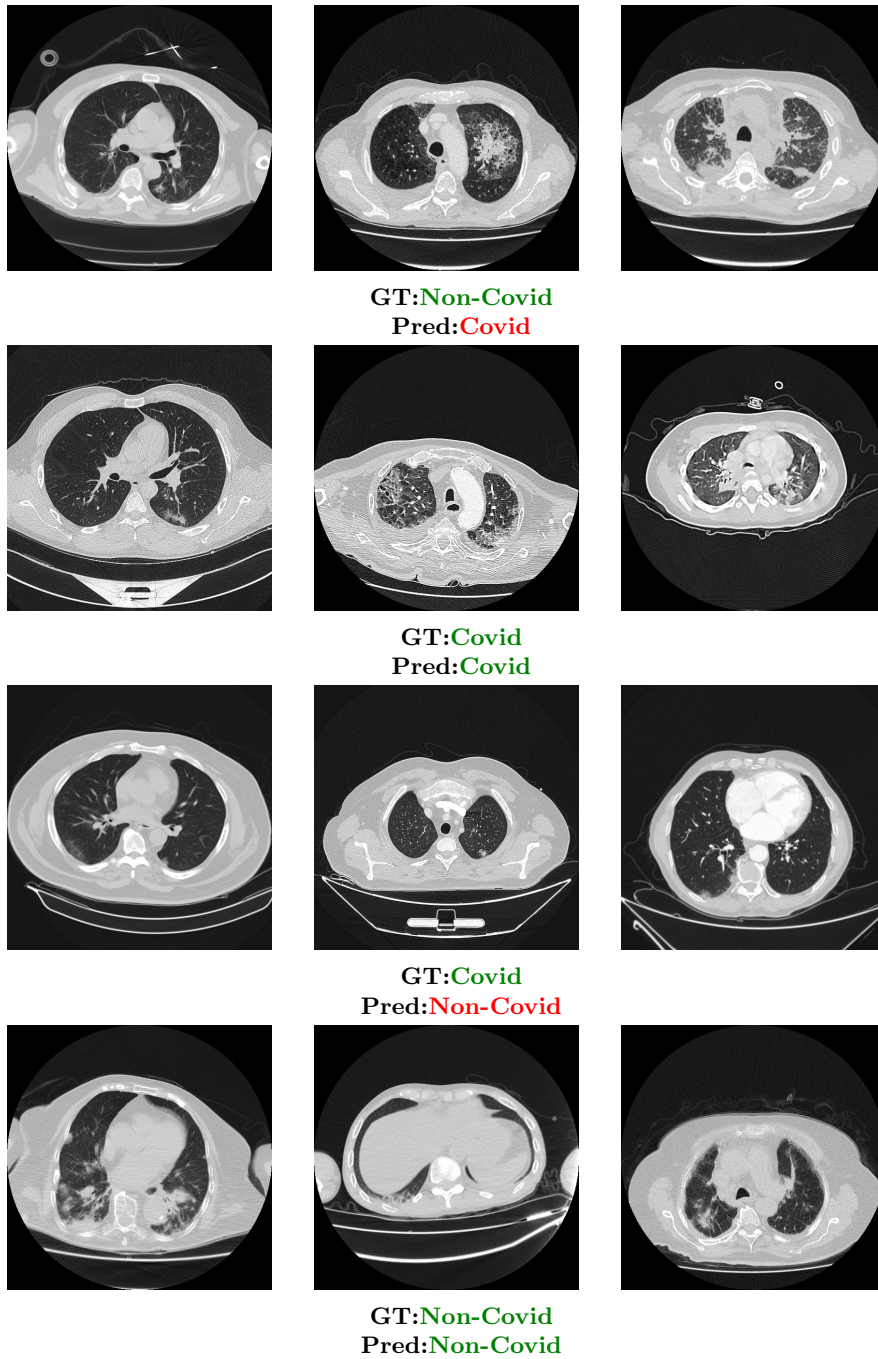

Fig. 3: Visualization illustration of some example slices from the predicted CT-scans. The first to the fourth rows show examples of wrongly predicted CT-scans as Covid-19, correctly predicted CT-scans as Covid-19, wrongly predicted CT-scans as Non-Covid-19, and CT-scans as Non-Covid-19, respectively.

## 5 Conclusion

In this work, we proposed two ensemble CNN-based approaches for the 2nd COV19D competition. For Covid-19 detection from CT scans, we proposed an ensemble of 2D convolution blocks with Densenet-161 models. Here, the individual convolution 2D blocks with Densenet-161 architecture are trained separately, and the ensemble model is based on the average of their probabilities at testing phase. On the other hand, we proposed an ensemble of Convolutional Layers with Inception models for Covid-19 severity detection. In addition to the Convolutional Layers, three Inception variants were used, namely Inception-v3, Inception-v4, and Inception-Resnet.

In the testing phase, our proposed approaches ranked fifth and third for Covid-19 detection and Covid-19 Severity detection, respectively. Furthermore, our approaches outperformed the baseline results by 18.37% and 6.81% for Covid-19 detection and Covid-19 Severity detection, respectively. In future work, we will evaluate our approaches in other datasets and use the attention mechanism to select the most representative slices for Covid-19 detection.

## 6 Acknowledgments

The authors would like to thank Arturo Argentieri from CNR-ISASI Italy for his support on the multi-GPU computing facilities.

## References

1. Arsenos, A., Kollias, D., Kollias, S.: A large imaging database and novel deep neural architecture for covid-19 diagnosis. In: 2022 IEEE 14th Image, Video, and Multidimensional Signal Processing Workshop (IVMSP). pp. 1–5. IEEE (2022)
2. Bougourzi, F., Dornaika, F., Mokrani, K., Taleb-Ahmed, A., Ruichek, Y.: Fusing Transformed Deep and Shallow features (FTDS) for image-based facial expression recognition. *Expert Systems with Applications* **156**, 113459 (Oct 2020). <https://doi.org/10.1016/j.eswa.2020.113459>
3. Bougourzi, F., Dornaika, F., Taleb-Ahmed, A.: Deep learning based face beauty prediction via dynamic robust losses and ensemble regression. *Knowledge-Based Systems* **242**, 108246 (Apr 2022)
4. Bougourzi, F., Contino, R., Distanto, C., Taleb-Ahmed, A.: CNR-IEMN: A Deep Learning Based Approach to Recognise Covid-19 from CT-Scan. In: ICASSP 2021 - 2021 IEEE International Conference on Acoustics, Speech and Signal Processing (ICASSP). pp. 8568–8572 (Jun 2021). <https://doi.org/10.1109/ICASSP39728.2021.9414185>, iSSN: 2379-190X
5. Bougourzi, F., Contino, R., Distanto, C., Taleb-Ahmed, A.: Recognition of COVID-19 from CT Scans Using Two-Stage Deep-Learning-Based Approach: CNR-IEMN. *Sensors* **21**(17), 5878 (Jan 2021). <https://doi.org/10.3390/s21175878>, number: 17 Publisher: Multidisciplinary Digital Publishing Institute
6. Bougourzi, F., Distanto, C., Dornaika, F., Taleb-Ahmed, A., Hadid, A.: ILC-Unet++ for Covid-19 Infection Segmentation. In: Mazzeo, P.L., Frontoni, E., Sclaroff, S., Distanto, C. (eds.) *Image Analysis and Processing. ICIAP 2022 Workshops*. pp. 461–472. Lecture Notes in Computer Science, Springer International Publishing, Cham (2022)
7. Bougourzi, F., Distanto, C., Ouafi, A., Dornaika, F., Hadid, A., Taleb-Ahmed, A.: Per-COVID-19: A Benchmark Dataset for COVID-19 Percentage Estimation from CT-Scans. *Journal of Imaging* **7**(9), 189 (Sep 2021). <https://doi.org/10.3390/jimaging7090189>, number: 9 Publisher: Multidisciplinary Digital Publishing Institute
8. Huang, G., Liu, Z., Van Der Maaten, L., Weinberger, K.Q.: Densely connected convolutional networks. In: *Proceedings of the IEEE conference on computer vision and pattern recognition*. pp. 4700–4708 (2017)
9. Jin, Y.H., Cai, L., Cheng, Z.S.e.a.: A rapid advice guideline for the diagnosis and treatment of 2019 novel coronavirus (2019-nCoV) infected pneumonia (standard version). *Military Medical Research* **7**(1), 4 (Feb 2020). <https://doi.org/10.1186/s40779-020-0233-6>
10. Kollias, D., Arsenos, A., Kollias, S.: Ai-mia: Covid-19 detection & severity analysis through medical imaging. arXiv preprint arXiv:2206.04732 (2022)
11. Kollias, D., Arsenos, A., Soukissian, L., Kollias, S.: Mia-cov19d: Covid-19 detection through 3-d chest ct image analysis. In: *Proceedings of the IEEE/CVF International Conference on Computer Vision*. pp. 537–544 (2021)
12. Kollias, D., Bouas, N., Vlaxos, Y., Brillakis, V., Seferis, M., Kollia, I., Sukissian, L., Wingate, J., Kollias, S.: Deep transparent prediction through latent representation analysis. arXiv preprint arXiv:2009.07044 (2020)
13. Kollias, D., Tagaris, A., Stafylopatis, A., Kollias, S., Tagaris, G.: Deep neural architectures for prediction in healthcare. *Complex & Intelligent Systems* **4**(2), 119–131 (2018)

14. Kollias, D., Vlaxos, Y., Seferis, M., Kollia, I., Sukissian, L., Wingate, J., Kollias, S.D.: Transparent adaptation in deep medical image diagnosis. In: TAILOR. p. 251–267 (2020)
15. Kucirka, L.M., Lauer, S.A., Laeyendecker, O., Boon, D., Lessler, J.: Variation in False-Negative rate of reverse transcriptase polymerase chain Reaction-Based SARS-CoV-2 Tests by time since exposure. *Annals of Internal Medicine* **173**(4), 262–267 (May 2020). <https://doi.org/10.7326/M20-1495>, publisher: American College of Physicians
16. Ma, J., Wang, Y., An, X., Ge, C., Yu, Z., Chen, J., Zhu, Q., Dong, G., He, J., He, Z., Cao, T., Zhu, Y., Nie, Z., Yang, X.: Toward data efficient learning: A benchmark for COVID 19 CT lung and infection segmentation. *Medical Physics* **48**, 1197–1210 (Mar 2021). <https://doi.org/10.1002/mp.14676>, <https://ui.adsabs.harvard.edu/abs/2021MedPh..48.1197M>, aDS Bibcode: 2021MedPh..48.1197M
17. Oktay, O., Schlemper, J., Folgoc, L.L.e.a.: Attention U-Net: Learning Where to Look for the Pancreas. arXiv:1804.03999 [cs] (May 2018), arXiv: 1804.03999
18. Paszke, A., Gross, S., Massa, F.e.a.: Pytorch: An imperative style, high-performance deep learning library. In: *Advances in neural information processing systems*. pp. 8026–8037 (2019)
19. RADIOLOGISTS: COVID-19 CT-scans segmentation datasets, available at: <http://medicalsegmentation.com/covid19/> (2019), last visited: 18-08-2021
20. Sun, Z., Zhang, N., Li, Y., Xu, X.: A systematic review of chest imaging findings in covid-19. *Quantitative imaging in medicine and surgery* **10**(5), 1058 (2020)
21. Szegedy, C., Vanhoucke, V., Ioffe, S., Shlens, J., Wojna, Z.: Rethinking the inception architecture for computer vision (2015)
22. Vantaggiato, E., Paladini, E., Bougourzi, F., Distanto, C., Hadid, A., Taleb-Ahmed, A.: Covid-19 recognition using ensemble-cnns in two new chest x-ray databases. *Sensors* **21**(5), 1742 (2021)
23. Wu, Y.H., Gao, S.H., Mei, J., Xu, J., Fan, D.P., Zhang, R.G., Cheng, M.M.: JCS: An Explainable COVID-19 Diagnosis System by Joint Classification and Segmentation. *IEEE Transactions on Image Processing* **30**, 3113–3126 (2021). <https://doi.org/10.1109/TIP.2021.3058783>, conference Name: IEEE Transactions on Image Processing
24. Xie, S., Girshick, R., Dollár, P., Tu, Z., He, K.: Aggregated residual transformations for deep neural networks (2017)