



HAL
open science

Private cellular network deployment: comparison of openAirInterface with magma core

Nischal Aryal, Fariba Ghaffari, Saeid Rezaei, Emmanuel Bertin, Noel Crespi

► To cite this version:

Nischal Aryal, Fariba Ghaffari, Saeid Rezaei, Emmanuel Bertin, Noel Crespi. Private cellular network deployment: comparison of openAirInterface with magma core. 2022 18th International Conference on Network and Service Management (CNSM), Oct 2022, Thessaloniki, Greece. pp.364-366, 10.23919/CNSM55787.2022.9964713 . hal-03959478

HAL Id: hal-03959478

<https://hal.science/hal-03959478>

Submitted on 7 Mar 2024

HAL is a multi-disciplinary open access archive for the deposit and dissemination of scientific research documents, whether they are published or not. The documents may come from teaching and research institutions in France or abroad, or from public or private research centers.

L'archive ouverte pluridisciplinaire **HAL**, est destinée au dépôt et à la diffusion de documents scientifiques de niveau recherche, publiés ou non, émanant des établissements d'enseignement et de recherche français ou étrangers, des laboratoires publics ou privés.

Private Cellular Network Deployment: Comparison of OpenAirInterface with Magma Core

^{1,2} Nischal Aryal, ^{1,2} Fariba Ghaffari, ^{1,3} Saeid Rezaei, ^{1,2} Emmanuel Bertin, ² Noel Crespi

¹ Orange Innovation, 14000 Caen, France

² IMT, Telecom SudParis, Institut Polytechnique de Paris, 91764 Palaiseau, France

³ Politecnico di Milano, Italy

{Nischal.aryal, Fariba.ghaffari, Saeid.rezaei, Emmanuel.bertin}@orange.com, and noel.crespi@it-sudparis.eu

Abstract—We present the deployment procedure of a private 4G-LTE network with standard User Equipment in two different scenarios using OpenAirInterface and Magma core networks. Our lessons learned from deploying the segregated end-to-end cellular network testbed, comparison of connection performance in two scenarios, challenges of connecting smartphones to the network, and comparison among the possible use-cases with each scenario are the highlighted subjects provided in this paper.

Index Terms—Private cellular network, OAI, Magma core.

I. INTRODUCTION

Recent development in cellular network shows a growing interest in interconnection among connected entities in a variety of use cases such as smart cities, wireless connections, autonomous vehicles, etc. This interconnection demands reliable communications, provision of diverse and innovative services, broader network coverage, and connection of all types of devices -regardless of their compatibility with specific standardization body¹- to the network [1]. So, there is a growing interest in Next Generation Networks (NGN) and its integration with a variety of technologies [2].

The importance of NGNs and requirements of new businesses highlights the need for an open market supporting the entrance of diverse service providers, small-scale operators, Micro-operators for local connectivity [3], and vendors to deploy their private cellular networks and serve their users and provide innovative services [4]. One scenario in this regard can be serving a small group of users (with diverse types of devices) in a rural area in which the network coverage of Mobile Network Operators (MNO) is not sufficient. In this scenario, a small-scale enterprise (or a small group of users), which can provide the Radio Access Network (RAN) part of the connection (e.g., by purchasing and providing antennas), would be able to adopt their private cellular network.

Small-scale deployment of private networks and comparison among different possible solutions are prerequisites for its real-life adoption. In this paper, we aim to provide a detailed demo of an implemented 4G-LTE private network (consists of UE with SIM-Card, Radio Access Network (RAN), and Core Network (CN)) with standard User Equipment (smartphone). In this regard, we selected two well-known projects (i.e., OpenAirInterface (OAI) [5] and Magma core network [6]).

OAI and Magma-core projects are the two main open-source projects to support the flexible deployment of small-scale mobile communication solutions, but with two different philosophies in their architecture and implementation. OAI project [7], created by EURECOM research institute, provides an architecture, fully compatible with 3GPP standards for implementation and deployment of standard cellular networks for 3GPP devices (such as smartphones). This project not only implements a core-network solution for 4G and 5G Standalone/Non-Standalone(SA/NSA) [8], [9] but also provides a RAN component. On the other hand, the Magma project provides a converged core network architecture to deploy mobile core networks in difficult-to-reach areas at a reasonable cost and to support not only the 3GPP-compliant devices but also the other types of connections (such as wireless) to build more “software native” solutions. It is important mentioning that the Magma project doesn’t provide an independent RAN solution.

This paper demonstrates the deployment of two private cellular networks for small-scale use cases. In the first scenario, the smartphone would be connected to OAI-RAN and send the packets to the internet through OAI-CN, while in the second one, we will replace OAI-CN with the Magma core. After successful End-to-End connection, we show the connection logs, performance monitoring and compare the latency, and CPU usage. Moreover, we discuss the following subjects:

- Deploying a disaggregated, End-to-End mobile network testbed, where eNodeB (i.e. the RAN entity) and the core network (i.e., both OAI-CN and Magma) are installed on separate systems. Discuss on interface challenges that arise while connecting eNodeB and the core network, and the solution to solve the issues.
- Discuss the use-cases in which each core network solution can be more useful. In this regard, we discuss the feasibility of deployment of these scenarios by comparing them against several important parameters such as compatibility with new business models and non-standard devices, their adaptability, reliability, and convergence.

II. TESTBED DEPLOYMENT

The overall architecture of the testbed is depicted in Figure 1. The list of hardware and software used during testbed

¹e.g., 3rd Generation Partnership Project (3GPP)

Table I
ENVIRONMENT SPECIFICATIONS

Entity	Parameter	Specification
Hardware		
OAI RAN	CPU	Intel Core i7-6700 CPU 3.40 GHz
	RAM	16 GB
	SDR board	USRP B210
OAI-CN and Magma	CPU RAM	Intel Xeon W-2102 CPU 2.90 GHz 16 GB
UE	Smartphone	Samsung S4
	SIM-card	Sysmocom SJS1
	SIM-card reader	Gemalto
Software		
OAI RAN	OAI-RAN	master branch release v1.1.0
	OS	Ubuntu 18.04-low latency kernel
	UHD	v4.1.0.0 branch
	pysim	master branch
OAI-CN and Magma	OS	Ubuntu 18.04 Bionic
	OAI-CN	master branch
	Magma Core	v1.7 branch

Table II
SIM CARD CONFIGURATION

Parameters	Values
ADM key	2611488
MCC (Mobile Country Code)	208
MNC (Mobile Network Code)	93
Name	OAI
IMSI	208930000008
Ki	8baf473f2f8fd09487
OPC	8e27b6af0e692e750f32667a3b14605d
ICCID	8988211000000285877
After programming the sim card and inserting it into the mobile phone, a custom access point network (APN) information with name and APN variables are set with value <i>oai.ipv4</i> in the smartphone.	

deployment are described in Table I. The information required to program the SIM card is shown in Table II, and Table III describes the *eNodeB* information modified in *enb.band7.tm1.50PRB.usrb210.conf* configuration file to connect RAN to core network.

III. DISCUSSION

The analysis on the performance of the system, the problems faced during the implementation, and the suitable use-cases are discussed below.

The throughput and latency parameters of connecting the smartphone to Magma-core and OAI-CN are shown in Fig. 2,

Table III
RAN CONFIGURATION

Parameters	Values
MCC (Mobile Country Code)	208
MNC (Mobile Network Code)	93
ipv4 of mme_ip_address (OAI-CN)	192.168.61.149
ipv4 of mme_ip_address (Magma)	192.168.61.149
ENB_INTERFACE_NAME_FOR_S1_MME	eno1
ENB_INTERFACE_NAME_FOR_S1U	eno1
ENB_IPV4_ADDRESS_FOR_S1_MME	192.168.1.215
ENB_IPV4_ADDRESS_FOR_S1U	192.168.1.215
Duplexing mode	FDD
Frequency band	Band 7
Physical Resource Block(PRB)s	50

Table IV
COMPARISON BETWEEN DEPLOYED TESTBEDS

Parameter	OAI-CN	Magma Core
Deployed CN modules	HSS, SPGW-C SPGW-U, MME	subscriberdb, MME, SPGW-C, control_proxy, health, enodebd, policydb, OVS sessiondb
Non-3GPP device support	No	Yes
Orchestration Module	No	Yes
Network Management Service	No	Yes
Converged core network support	No	Yes
Heterogeneity in access technology and business models *	Low	High
Network architecture heterogeneity	Low	High
Self-healing feature	No	Yes **
Open-source software used	Docker, Cassandra, Redis	Virtual box, Vagrant, Docker

* To be able to connect different technologies such as LTE, 5G, CPRS, wireless, etc. and business models (e.g., The existing MME for 4G access technology can be used for 5G Magma core on the same AGW.)

** The health module periodically checks the state of other network modules and reports to orchestrator

which indicates the throughput for both scenarios are almost the same, but merely UL data throughput is better in OAI-CN scenario. Moreover, CPU tracking shows that OAI-CN merely uses 9 – 10% while this statistic for Magma core is 3 – 4%. CPU usage for eNodeB is around 60%.

A. Main problems faced

- **RAN:** To avoid the *overflow* problem, the *eNodeB* software depended on a low-latency kernel for *Ubuntu* and processors that supported *avx2* instructions.
- **Interface:** To solve the problem of discovering the IPs of RAN and core network, a proper routing table, packet forwarding rules in *iptables*, and port forwarding should be added (see the routing comment boxes in Fig. 1).

B. Discussion on suitable use-cases

The most highlighted difference between Magma-core and OAI-CN is in their supported use-cases. OAI-CN brings a solution for 3GPP-compliant small-scale networks, which lack the flexibility on serving non-cellular network use-cases such as Wi-Fi connections. On the other hand, Magma-core provides a more flexible and software-native solution to converge a variety of access technologies through Magma Access Gateway. Moreover, it has the opportunity of defining policies and charging rules, HSS, etc. by the mobile network operators. Therefore, we can say that the Magma breakout scenario will be used to provide a low-cost connectivity solution for rural areas by utilizing a low-cost and open-source access gateway that federates traffic to the core of a MNO via standard interfaces using the *Diameter* protocol.

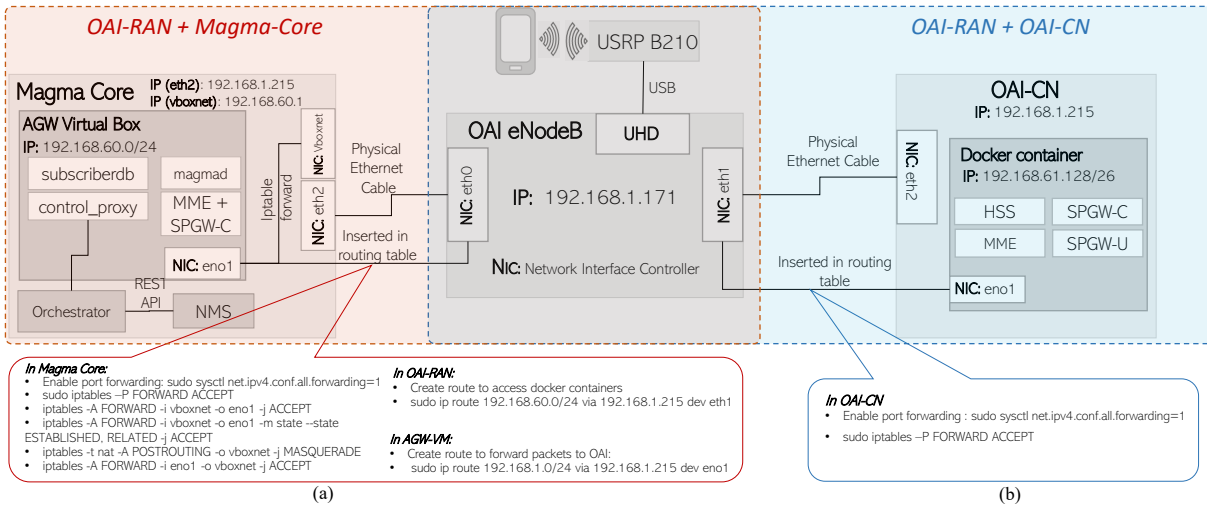

Figure 1. Architecture of deployed testbed. (a) the red box denotes *Smartphone* ↔ *OAI – RAN+Magma – CN*, and (b) the blue box shows *Smartphone* ↔ *OAI – RAN+OAI – CN*. The intersection of two boxes depict *OAI-RAN* common to both scenarios.

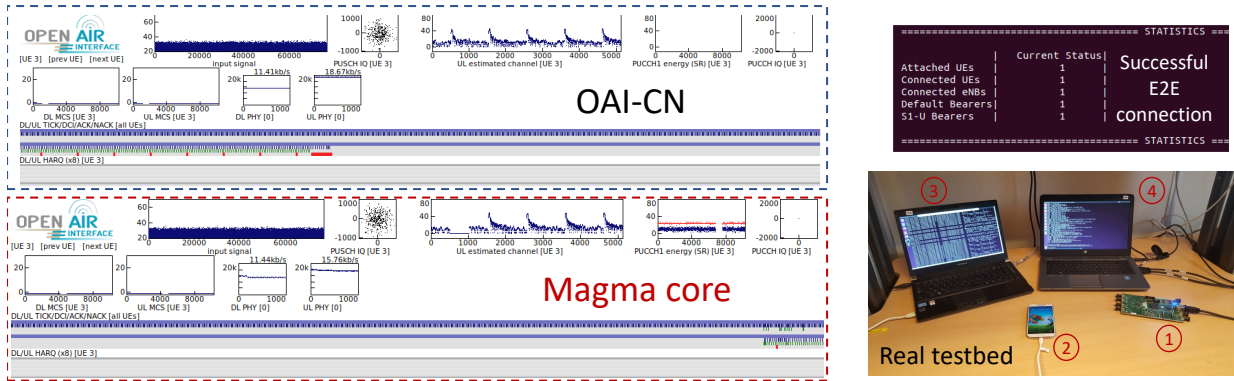

Figure 2. Monitoring the performance of the end-to-end connection using *Tracer* (left side) and *MME – log* (right-up). Deployed testbed (right-down: 1) Antenna USRP B210, 2) Smartphone (Samsung galaxy S4), 3) Core network, 4) OAI-RAN.

It is important to mention that, although Magma-core has the aforementioned advantages, generally it suffers from the immaturity of code and documentation, as well as the complexity of deployment of each component in separate physical devices. The OAI tutorials and source codes are mature as compared to Magma, however, it lacks up-to-date documentation, especially for the RAN entity.

REFERENCES

[1] Y. Zhao, J. Zhao, W. Zhai, S. Sun, D. Niyato, and K.-Y. Lam, “A survey of 6g wireless communications: Emerging technologies,” in *Future of Information and Communication Conference*. Springer, 2021, pp. 150–170.

[2] A. Slalmi, H. Chaibi, A. Chehri, R. Saadane, and G. Jeon, “Toward 6g: Understanding network requirements and key performance indicators,” *Transactions on Emerging Telecommunications Technologies*, vol. 32, no. 3, p. e4201, 2021.

[3] P. Ahokangas, M. Matinmikko-Blue, S. Yrjölä, V. Seppänen, H. Hämmäinen, R. Jurva, and M. Latva-aho, “Business models for local 5g micro operators,” *IEEE Transactions on Cognitive Communications and Networking*, vol. 5, no. 3, pp. 730–740, 2019.

[4] M. Moussaoui, E. Bertin, and N. Crespi, “Telecom business models for beyond 5g and 6g networks: Towards disaggregation?” in *2022 1st*

International Conference on 6G Networking (6GNet). IEEE, 2022, pp. 1–8.

[5] “OpenAirInterface – 5G software alliance for democratising wireless innovation.” [Online]. Available: <https://openairinterface.org/>

[6] “Magma – Linux Foundation Project.” [Online]. Available: <https://magmacore.org/>

[7] N. Nikaein, M. K. Marina, S. Manickam, A. Dawson, R. Knopp, and C. Bonnet, “Openairinterface: A flexible platform for 5g research,” *ACM SIGCOMM Computer Communication Review*, vol. 44, no. 5, pp. 33–38, 2014.

[8] “Lte; general packet radio service (gprs) enhancements for evolved universal terrestrial radio access network (e-utran) access (3gpp ts 23.401 version 11.3.0 release 11),” 2012. [Online]. Available: https://www.etsi.org/deliver/etsi_ts/123400_123499/123401/11.03.00_60/ts_123401v110300p.pdf

[9] “5g; system architecture for the 5g system (3gpp ts 23.501 version 15.3.0 release 15),” 2018. [Online]. Available: https://www.etsi.org/deliver/etsi_ts/123500_123599/123501/15.03.00_60/ts_123501v150300p.pdf