



HAL
open science

On state estimation for non-linear systems under random access wireless protocols

Alejandro Maass, Dragan Netic, Romain Postoyan, Ying Tan

► **To cite this version:**

Alejandro Maass, Dragan Netic, Romain Postoyan, Ying Tan. On state estimation for non-linear systems under random access wireless protocols. *Mathematics of Control, Signals, and Systems*, 2023, 35 (1), pp.187-213. 10.1007/s00498-022-00337-y . hal-03926329

HAL Id: hal-03926329

<https://hal.science/hal-03926329v1>

Submitted on 6 Jan 2023

HAL is a multi-disciplinary open access archive for the deposit and dissemination of scientific research documents, whether they are published or not. The documents may come from teaching and research institutions in France or abroad, or from public or private research centers.

L'archive ouverte pluridisciplinaire **HAL**, est destinée au dépôt et à la diffusion de documents scientifiques de niveau recherche, publiés ou non, émanant des établissements d'enseignement et de recherche français ou étrangers, des laboratoires publics ou privés.



Distributed under a Creative Commons Attribution 4.0 International License

On state estimation for non-linear systems under random access wireless protocols

Alejandro I. Maass^{1*}, Dragan Nešić¹, Romain Postoyan² and Ying Tan³

¹Department of Electrical and Electronic Engineering, The University of Melbourne, Melbourne, 3010, VIC, Australia.

²CRAN, CNRS, Université de Lorraine, Nancy, F-5400, France.

³Department of Mechanical Engineering, The University of Melbourne, Melbourne, 3010, VIC, Australia.

*Corresponding author(s). E-mail(s): maassa@unimelb.edu.au;

Contributing authors: dnesic@unimelb.edu.au;

romain.postoyan@univ-lorraine.fr; yingt@unimelb.edu.au;

Abstract

This article is dedicated to Eduardo D. Sontag on the occasion of his 70th birthday. We build upon fundamental stability concepts developed by Sontag, such as input-to-state stability and its related properties, to study a relevant application in industrial internet of things, namely, estimation for wireless networked control systems. Particularly, we study emulation-based state estimation for non-linear plants that communicate with a remote observer over a shared wireless network subject to packet losses. To reduce bandwidth usage, a stochastic communication protocol is employed to determine which node should be given access to the network. Each node has a different successful transmission probability. We describe the overall closed-loop system as a stochastic hybrid model, which allows us to capture the behaviour both between and at transmission instants, whilst covering network features such as random transmission instants, packet losses, and stochastic scheduling. We then provide sufficient conditions on the transmission rate that guarantee an input-to-state stability property (in expectation) for the corresponding estimation error system. We illustrate our results in the design of circle criterion observers.

Keywords: Wireless networked control systems, Emulation, State estimation, Stochastic protocols.

1 Introduction

Eduardo D. Sontag has proposed and developed a number of novel concepts in fields ranging from control theory and theoretical computer science, to learning and systems biology. Of greatest interest to this work are the novel tools introduced by Sontag in the 1980s and 1990s for studying the effect of external inputs on the stability of non-linear systems, namely *input-to-state stability* (ISS) [1] and its related properties [2]. These concepts have been widely recognised as central paradigms in control engineering research. Particularly, the notion of ISS quickly became a foundational concept upon which much of modern non-linear feedback analysis and design rest, see e.g., [3, 4]. Additionally, input-to-state stability led to related notions such as *integral ISS* [5], *derivative ISS* (DISS) [6], *input-to-output stability* (IOS) [7], together with important characterisations of forward completeness [8], amongst others. Applications of ISS are now widespread, which—to cite a few—include: singular perturbation analysis [9], small-gain theorems [10], tracking design [11], and observer design [12, 13]. Relevant

to this work are the contributions of ISS to the area of networked control systems (NCSs), see e.g., [14–16]. Within this context, ISS (and other IOS-like properties) is adopted as the right notion to formalise the effect of network imperfections on the controller (or observer). In this work, we build upon the aforementioned stability concepts developed by Sontag to study an important control engineering problem relevant to industrial internet of things (IIoT) applications, which is estimation for wireless networked control systems (WNCSs).

Advances in wireless technology are revolutionising how control systems exchange information with physical processes [17]. In WNCSs, the sensor and actuator information is transmitted to a remote controller over a shared wireless network. WNCSs provide several advantages over control systems based on wired counterparts, e.g., improved flexibility, reduced maintenance costs, and simple deployment of additional measurement points. Particularly, wireless technology has proven to be successful in replacing wired control systems with wireless ones even in complex industrial environments, see e.g., [18]. However, wireless networks also introduce communication constraints that include, but are not limited to, packet losses, data collisions, time-varying transmission instants, and delays. Therefore, in order to have efficient design solutions for these systems, the wireless network and its corresponding constraints have to be considered explicitly in the analysis.

Due to bandwidth limitations, simultaneous transmission of multiple sensors via a shared network may cause data collisions or network congestion. An effective way to alleviate the possible information loss is the implementation of communication protocols to aid the scheduling of signal transmissions. Particularly, communication protocols determine which node should obtain access to the shared wireless network at a particular transmission instant. In the literature, we can find static protocols like round-robin [19], in which nodes are assigned to a particular timeslot in a predetermined and cyclic manner, and dynamic protocols like maximum-error-first try-once-discard [20], where the node with the greatest weighted error will be granted access to the network. Moreover, stochastic (also called random access) protocols can also be used to avoid collisions [21], and these have received a lot of attention recently in the literature since they model carrier-sense multiple access with collision avoidance (CSMA/CA) protocols that arise in IEEE 802.15.4-based industrial wireless networks such as WirelessHART for instance [22, 23].

Stochastic protocols have been widely studied in the context of controller design of linear WNCS in [24–28], in [29] for a class of non-linear WNCS, and our previous works [21, 23] for general non-linear WNCS. Recently, stochastic protocols have also been studied for the remote state estimation problem, see e.g., [30–32] for results on linear systems, and [33–37] for results on special classes of non-linear systems. Particularly, all these works focus on discrete-time models (either linear or a special class of non-linear) for the underlying WNCS, and thus consider periodic and deterministic transmissions for the network. These models can be limiting since they are only valid at each sample time, thus the inter-sample behaviour is lost, and also disregard the stochastic nature of wireless transmissions. Additionally, none of these works considered that the node with granted network access may also be subject to packet dropouts due to the wireless environment. To the best of our knowledge, there are no available results in the literature that provide a fully non-linear framework for the remote state estimation of WNCS under stochastic scheduling protocols, random packet losses, and random transmission instants.

In response to the above discussion, this paper provides an emulation-based framework for state estimation of general non-linear plants that communicate with an observer via a wireless network that adopts a stochastic protocol, and where each node is subject to random packet losses. The emulation approach has been vastly used in the study of NCSs, see e.g., [14, 20, 38]. In our context, the first step of emulation consists in designing an appropriate observer to estimate the plant state in absence of the wireless network, i.e., as in a standard wired and analogue control loop. Then, we aim to provide sufficient conditions on the network for which the original stability property of the observer is preserved when it is implemented over the wireless network. To this end, we propose a stochastic hybrid model for the WNCS that captures the continuous dynamics of both the plant and observer, and the discrete dynamics of the network in terms of transmissions and dropouts. This class of models encompasses both the linear and classes of non-linear models found in the aforementioned literature, and it allows us to capture in a higher-fidelity fashion the effects of the underlying wireless network. Using the obtained WNCS model, we provide a sufficient condition on the rate of transmission that

ensures a DISS [6] property on the corresponding estimation error system. This sufficient condition translates into a bound on the transmission rate under which, in absence of inputs, the mean of the estimation error converges to zero.

As foreshadowed at the start, our analysis tools are highly inspired by the work of Sontag in [1], where the ISS notion was precisely introduced. Particularly, to provide our stability results, we adopt small-gain arguments and forward completeness characterisations, for which the ISS definition becomes very important and natural, see e.g., [8, 10]. In our particular setup, our analysis considers the interconnection between three subsystems, namely the estimation error subsystem, the observer subsystem, and the network-induced error subsystem. We assume different input-output requirements for each subsystem and provide a small-gain theorem that ensures a DISS property for the estimation error system, and a forward completeness property for the overall system.

Our contributions can be summarised as follows.

- The presented results are valid for a larger class of models with respect to available literature. Note that all available results are either for linear systems or specific classes of non-linear systems [30–37]. Moreover, we adopt a stochastic hybrid systems approach, as opposed to purely discrete like in the aforementioned works. This allows us to cover both the continuous behaviour of the plant, and the discrete dynamics from the network (stochastic transmissions and packet losses). In addition, we consider non-linear plants subject to external disturbances and measurement noise.
- Our modelling tools build upon the \mathcal{L}_p stability work in [21, 39], where stochastic models for the controller design problem were presented. We emphasise that there are important technical differences in the analysis since the observer design problem considered in this paper requires convergence of the estimation error (in absence of inputs) as opposed to only \mathcal{L}_p stability, and this has to be handled carefully given the random transmission instants and dropouts. In this context, a different analysis that uses tools such as dominated convergence theorem is performed.
- This proposal also serves as the stochastic counterpart of our previous work on observer design in a deterministic setting [40]. We note that in [40], successive transmissions are uniformly (deterministically) bounded by a maximum allowable transmission interval (MATI). We highlight that wireless networks naturally exhibit stochastic phenomena. Therefore, in order to tackle observer design in WNCS settings, this work provides a more suitable framework than [40], for which the structure of the wireless network given by multiple channel probabilities of success and random transmission times are taken into account.
- Lastly, we extend our recent stochastic work [41] on observer design to a more general case where each node is subject to its own packet loss process. This tailors to more realistic wireless networks, in which the distances between node transmitters and receivers—and the physical environment between them—may be different, leading to different packet loss probabilities for each node.

Notation

Let $\mathbb{N} := \{0, 1, 2, \dots\}$ and $\mathbb{N}_{>0} := \mathbb{N} \setminus \{0\}$. Denote by \mathbb{R}^n the set of all real vectors with $n \in \mathbb{N}_{>0}$ components, and let $\mathbb{R}_{\geq 0} := [0, \infty)$. Given $t \in \mathbb{R}$ and a piecewise continuous function $f : \mathbb{R} \rightarrow \mathbb{R}^n$, we define $f(t^+) := \lim_{s \rightarrow t, s > t} f(s)$. Given $a \in (0, \infty]$, a function $\alpha : [0, a) \rightarrow \mathbb{R}_{\geq 0}$ is of class \mathcal{K} if it is continuous, zero at zero and strictly increasing. It is of class \mathcal{K}_∞ if it is of class \mathcal{K} with $a = \infty$, and unbounded. For $a, b \in (0, \infty]$, a function $\gamma : [0, a) \times [0, b) \rightarrow \mathbb{R}_{\geq 0}$ is of class $\mathcal{K}\mathcal{K}$ if, for any $(s_1, s_2) \in (0, a) \times (0, b)$, $\gamma(s_1, \cdot)$ and $\gamma(\cdot, s_2)$ are of class \mathcal{K} . A continuous function $\beta : \mathbb{R}_{\geq 0} \times \mathbb{R}_{\geq 0} \rightarrow \mathbb{R}_{\geq 0}$ is of class $\mathcal{K}\mathcal{L}$ if $\beta(\cdot, t)$ is of class \mathcal{K} for each $t \geq 0$, and if $\beta(s, \cdot)$ is non-increasing and satisfies $\lim_{t \rightarrow \infty} \beta(s, t) = 0$ for each $s \geq 0$. For any $x \in \mathbb{R}^n$ and $y \in \mathbb{R}^m$, we use $(x, y) := [x^\top \ y^\top]^\top \in \mathbb{R}^{n+m}$. I_n stands for the identity matrix of dimension $n \times n$, and $\mathbf{1}_{n \times m}$ denotes a $n \times m$ matrix with all elements equal to 1. For $x \in \mathbb{R}^n$, $|x|$ denotes the standard Euclidean norm, and also the induced 2-norm for a real matrix. For $x = (x_1, \dots, x_n) \in \mathbb{R}^n$, $\bar{x} = (|x_1|, \dots, |x_n|)$. For any matrix M , the entries of \bar{M} are the absolute values of the corresponding entries of M . $\text{diag}\{M_1, \dots, M_N\}$ returns the block diagonal matrix with the matrices M_1, \dots, M_N along the diagonal. Let $x = (x_1, \dots, x_n) \in \mathbb{R}^n$ and $y = (y_1, \dots, y_n) \in \mathbb{R}^n$, a partial order \preceq is given by $x \preceq y \Leftrightarrow x_i \leq y_i$, for all $i \in \{1, \dots, n\}$. Given a (Lebesgue) measurable

function $f : \mathbb{R} \rightarrow \mathbb{R}^n$, $\|f\|_{\mathcal{L}_p} := (\int_{\mathbb{R}} |f(s)|^p ds)^{1/p}$, for $p \in \mathbb{N}_{>0}$, $\|f\|_{\mathcal{L}_\infty} := \text{ess sup}_{t \in \mathbb{R}} |f(t)|$, and $\|f\|_{\mathcal{L}_\infty[a,b]} := \text{ess sup}_{t \in [a,b]} |f(t)|$. We say that $f \in \mathcal{L}_p$ for $p \in \mathbb{N}_{>0} \cup \{+\infty\}$ whenever $\|f\|_{\mathcal{L}_p} < \infty$. Given $[a,b] \subset \mathbb{R}$, $\|f\|_{\mathcal{L}_p[a,b]} := (\int_{[a,b]} |f(s)|^p ds)^{1/p}$ denotes the \mathcal{L}_p norm of f when restricted to the interval $[a,b]$. The underlying complete probability space is taken to be $(\Omega, \mathcal{F}, \mathbb{P})$, with Ω the sample space, \mathcal{F} the σ -algebra, and $\mathbb{P}\{\cdot\}$ the probability measure. The expectation operator is denoted by $\mathbb{E}\{\cdot\}$. For a measurable function $g : \Omega \times \mathbb{R} \rightarrow \mathbb{R}^n$, we say that $g \in \mathcal{L}_\infty^e[a,b]$ whenever $\mathbb{E}\{\|g\|_{\mathcal{L}_\infty[a,b]}\} < \infty$, given $[a,b] \subset \mathbb{R}$. By *i.i.d.* we mean *independent and identically distributed*. \square

2 Problem formulation and modelling

We study the scenario depicted in Fig. 1, where a non-linear plant communicates with an observer via a random access wireless network subject to packet losses. In this section, we formally describe each block in Fig. 1, and state the considered problem. Particularly, to design the observer we adopt an *emulation-based* approach, see e.g., [14, 16, 20, 38]. That is, we first design an observer that estimates the state of the plant (1)—in some appropriate sense—without taking into account the wireless network. Any of the available techniques for non-linear observer design can be used at this stage. In the next stage of emulation, the observer is implemented over the network, and thus the goal of this paper is to provide conditions on the observer and the network under which the state estimate \tilde{x}_p (approximately) converges to the state of the plant x_p . To fulfil this goal, we build upon the modelling framework in [21, 42] on controller design, and use similar assumptions for our estimation problem.

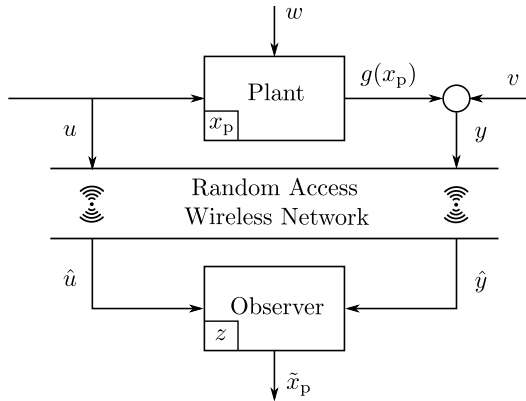

Fig. 1 Block diagram of the estimation architecture.

2.1 Plant and observer

The plant model is given by

$$\dot{x}_p = f_p(x_p, u, w), \quad y = g(x_p) + v, \quad (1)$$

where $x_p \in \mathbb{R}^{n_x}$ is the state, $u \in \mathbb{R}^{n_u}$ is the control input, $w \in \mathbb{R}^{n_w}$ is the external disturbance, $y \in \mathbb{R}^{n_y}$ is the plant output affected by the noise $v \in \mathbb{R}^{n_y}$, and $n_x, n_u, n_w, n_y \in \mathbb{N}_{>0}$. The functions $u : \mathbb{R} \rightarrow \mathbb{R}^{n_u}$ and $v : \mathbb{R} \rightarrow \mathbb{R}^{n_y}$ are Lebesgue measurable and differentiable almost everywhere. Moreover, these functions and their time-derivatives are assumed to have a finite \mathcal{L}_∞ norm.

For the sake of generality, we assume the designed observer has the form

$$\dot{z} = f_o(z, u, y - y_z), \quad \tilde{x}_p = g_o(z), \quad y_z = g(\tilde{x}_p), \quad (2)$$

where $z \in \mathbb{R}^{n_z}$ is the observer state, $n_z \in \mathbb{N}_{>0}$, $\tilde{x}_p \in \mathbb{R}^{n_x}$ is the estimate of the state x_p , and $y_z \in \mathbb{R}^{n_y}$ is the output estimate. Note that we allow the dimension of the observer to be different than the system dimension, hence covering immersion-based and reduced-order

observers for instance. It is implicit in (2) that we measure u and y , whereas w and v are unmeasured. The stability property we will prove is natural for this setting.

We emphasise that in the wireless scenario in Fig. 1, the observer has no longer access to (y, u) as in the classical state estimation case, but to the wireless versions (\hat{y}, \hat{u}) that are discussed next.

2.2 Wireless network dynamics

Before introducing the dynamics of the wireless signals (\hat{y}, \hat{u}) , we define the transmission times, the network nodes, and the packet loss processes. Particularly, in wireless networks, because of synchronisation routines, acknowledgement packets, waiting times, etc., transmissions instants are naturally stochastic. In this context, it is common to model them by using renewal processes, and we use a Poisson point process as formalised in the assumption below, see also [43–45].

Standing Assumption 1 Consider a Poisson point process $r(\cdot)$ with rate $\lambda \in \mathbb{R}_{>0}$ that satisfies $r(t) = 0$ for $t \in [0, t_0)$ and $r(t) = k$ for $t \in [t_{k-1}, t_k)$, where $\{t_k\}_{k \in \mathbb{N}}$ denotes the sequence of transmission instants defined inductively by: $t_0 = \tau_0$ with $\tau_0 \sim \text{Exp}(\lambda)$, and for each $k \in \mathbb{N}_{>0}$, $t_k = t_{k-1} + \tau_k$, with $\tau_k \sim \text{Exp}(\lambda)$, where the sequence $\{\tau_k\}_{k \in \mathbb{N}}$ is i.i.d. \square

The times $\{t_k\}_{k \in \mathbb{N}}$ are also called *arrival times* in the literature [46], $\{\tau_k\}_{k \in \mathbb{N}}$ are called *inter-transmission times* (or *inter-arrival times*), $\bar{\tau} := 1/\lambda$ represents the *average inter-transmission time*, and λ is the *arrival rate*. Throughout this paper, we will use the terms arrival rate and transmission rate interchangeably. The exponential distribution that governs each τ_k describes the time between transmissions.

We next define the concept of *network node* or *cluster*. A node consists of several sensors and/or actuators (grouped either by their spatial location or merely by convention) with their corresponding data being transmitted at the same transmission instant. Let $\mathbf{q} := (y, u)$. To depict the network nodes, we write, after re-ordering (if necessary), $\mathbf{q} = (\mathbf{q}_1, \dots, \mathbf{q}_N)$, where each partition \mathbf{q}_j is of size $n_j \in \{1, \dots, n_y + n_u\}$, $j \in \mathcal{N} := \{1, \dots, N\}$, and $\sum_{j=1}^N n_j = n_y + n_u =: n$. The total number of nodes in the network is thus equal to N . Each node transmission is subject to random packet loss, and to model it, we introduce a Bernoulli process $\{\theta_{j,k}\}_{k \in \mathbb{N}}$ for each network node \mathbf{q}_j , $j \in \mathcal{N}$, which satisfies $\theta_{j,k} = 1$ for a successful transmission with probability of success equal to p_j , and $\theta_{j,k} = 0$ if the packet is lost with probability $1 - p_j$. We note that this generalises the packet loss model in [21], where only a single Bernoulli process would govern the transmissions for all nodes.

Standing Assumption 2 The packet loss processes $\{\theta_{m,k}\}_{k \in \mathbb{N}}$ and $\{\theta_{n,k}\}_{k \in \mathbb{N}}$ are independent for all $m \neq n$, with $m, n \in \mathcal{N}$, and, for each $j \in \mathcal{N}$, $\{\theta_{j,k}\}_{k \in \mathbb{N}}$ is independent of $\{\tau_k\}_{k \in \mathbb{N}}$. \square

This is a standard assumption in NCS literature that considers Bernoulli packet losses and multiple links, see e.g., [47]. Different packet loss models such as the Gilbert-Elliott model [48] are of interest for future work.

We are now ready to introduce the dynamics of $\hat{\mathbf{q}} = (\hat{y}, \hat{u})$. At each transmission instant t_k , $k \in \mathbb{N}$, only one node is granted access to the network according to a stochastic scheduling protocol, which will be described further below. Suppose that the node $j \in \mathcal{N}$, is granted access to the network at time t_k , then,

$$\hat{\mathbf{q}}_j(t_k^+) = \begin{cases} \mathbf{q}_j(t_k), & \text{if } \theta_{j,k} = 1, \\ \hat{\mathbf{q}}_j(t_k), & \text{if } \theta_{j,k} = 0. \end{cases}$$

That is, if node $j \in \mathcal{N}$ is granted access to the network, the corresponding components of the received signal are updated with the sent signal provided the transmission was successful ($\theta_{j,k} = 1$), and the components are kept unchanged in case of a packet loss ($\theta_{j,k} = 0$). On the other hand, every other node that was not granted access to the network satisfies, for any $\theta_k \in \{0, 1\}$, $\hat{\mathbf{q}}_i(t_k^+) = \hat{\mathbf{q}}_i(t_k)$, for $i \neq j$.

Between transmission instants, i.e., for $t \in [t_k, t_{k+1}]$, $\hat{\mathbf{q}} = (\hat{y}, \hat{u})$ is generated according to the in-network processing implementation. For simplicity, we use zero-order hold devices which

translates into $\dot{\hat{y}} = 0$ and $\dot{\hat{u}} = 0$ for $t \in [t_k, t_{k+1}]$ and $k \in \mathbb{N}$. Note that this can be easily relaxed as in, e.g., [14].

Since the designed observer (2) is implemented over the wireless network as per Figure 1, it no longer receives (y, u) but (\hat{y}, \hat{u}) according to the dynamics presented above. This implies that (2) becomes

$$\dot{z} = f_o(z, \hat{u}, \hat{y} - \hat{y}_z). \quad (3)$$

Furthermore, we note that (3) does not depend on its output y_z , as in (2), but on \hat{y}_z , which is an artificially introduced networked version of y_z . The idea of using \hat{y}_z instead of y_z was suggested in [49, Section VIII] and it allows stronger stability properties for the estimation error system to be established. A similar idea was proposed in [50] for the design of high-gain observers. The variable \hat{y}_z is constructed to evolve along the same vector field as \hat{y} between two successive transmission instants, i.e., $\dot{\hat{y}}_z = 0$ for $t \in [t_k, t_{k+1}]$. Let $y_z = (y_{z,1}, \dots, y_{z,n_y})$ and $\hat{y}_z = (\hat{y}_{z,1}, \dots, \hat{y}_{z,n_y})$. At each successful transmission of a component of \hat{y} , say \hat{y}_{j_y} with $j_y \in \{1, \dots, n_y\}$, the corresponding component of \hat{y}_z , that is \hat{y}_{z,j_y} , is reset to y_{z,j_y} , that is

$$\hat{y}_{z,j_y}(t_k^+) = \begin{cases} y_{z,j_y}(t_k), & \text{if } \hat{y}_{j_y}(t_k^+) = y_{j_y}(t_k), \\ \hat{y}_{z,j_y}(t_k), & \text{otherwise.} \end{cases} \quad (4)$$

2.3 Random access wireless protocol

As mentioned earlier, we consider a scenario where transmissions in the wireless network are governed by a random access protocol, also known as stochastic protocol [21]. To aid its definition, and to facilitate analysis, we define the notion of *network-induced error*. Particularly, the network-induced error on the plant output is defined as $e^y := \hat{y} - y$, and the error on the input is $e^u := \hat{u} - u$. We also define a network-induced error on the observer output $e^{y_z} := \hat{y}_z - y_z$. Using these definitions, we rewrite (3) as

$$\dot{z} = f_o(z, u + e^u, y - y_z + e^y - e^{y_z}). \quad (5)$$

We can see that the dynamics of the observer are affected by $e^y - e^{y_z}$ and e^u , thus we define the overall network-induced error as $e := (e^y - e^{y_z}, e^u) \in \mathbb{R}^n$. As per the definition of node/cluster in Section 2.2, the network-induced error e is partitioned into N nodes as $e = (e_1, \dots, e_N)$. The introduction of the network-induced error allows us to model transmissions in a simpler way. Specifically, if at transmission instant t_k node $j \in \mathcal{N}$ is granted network access, and provided the transmission is successful, then the dynamics in Section 2.2 imply the corresponding error component satisfies $e_j(t_k^+) = 0$, while the remaining components are kept unchanged.

The random access protocol is defined as follows: At each transmission instant, and randomly, only one of the contending nodes $\{1, \dots, N\}$ gets network access. Given the network dynamics in Section 2.2, we can formally write an equation that describes this mechanism. That is,

$$e(t_k^+) = Q_k e(t_k) := \Theta_k \mathcal{H}_k e(t_k) + (I_n - \Theta_k) e(t_k), \quad (6)$$

where $\Theta_k := \text{diag}\{\theta_{1,k} I_{n_1}, \dots, \theta_{N,k} I_{n_N}\}$ contains the packet loss processes $\theta_{j,k}$ for every node $j \in \mathcal{N}$, $\{\mathcal{H}_k\}_{k \in \mathbb{N}}$ are i.i.d. random matrices taking values in the finite set $\mathbb{M} := \{M_1, \dots, M_N\}$, where M_j is the $n \times n$ matrix such that $M_j e = (e_1, \dots, e_{j-1}, 0, e_{j+1}, \dots, e_N)$ for any $j \in \mathcal{N}$ and $e \in \mathbb{R}^n$. That is, each M_j sets to zero the j -th component of the network-induced error and keeps the other components unchanged. Hence, the set \mathbb{M} contains all the possible matrices that result from each contending node getting access to transmit. Therefore, the random access protocol is such that, at each transmission instant t_k , \mathcal{H}_k will be equal to some M_j . The probability that node j transmits successfully through the network is given by $\mathbb{P}\{Q_k = M_j\} = p_j/N$ for $j \in \mathcal{N}$. For a setting where the network is purely deterministic, the authors in [42] introduced the notion of persistently exciting (PE) protocols. Essentially, a PE protocol would visit every network node at least once in a finite number of transmissions. Later on, this notion was extended to the stochastic case in [21] and named *almost surely (a.s.) covering protocol*. Before defining a.s. covering protocols, we introduce two preliminary definitions, *cover times* and *covering sequence*.

Definition 1 (Cover time) For any $k \in \mathbb{N}$, the k -th *cover time*, denoted by T_k , is defined as $T_k := \min \{j \geq 1 : \{M_1, \dots, M_N\} \subset \{Q_{T_{k-1}}, \dots, Q_{T_{k-1}+j-1}\}\}$, and $T_{-1} = 0$. \square

Collectively, $\{T_k\}_{k \in \mathbb{N}}$ is referred to as the cover time process. Cover times are the times in which every network node has successfully transmitted at least once. In our context, this notion is closely related to the cover time of an undirected graph, see e.g., [51], and the Coupon Collector's problem [52].

Definition 2 (Covering sequence) Let $\tau_k = t_k - t_{k-1}$ satisfy Assumption 1. We say that $C(i, k) := \{(Q_i, \tau_i), \dots, (Q_k, \tau_k)\}$ is a *covering sequence* if and only if for any $i \in \mathbb{N}$ there exists $k \geq i$ such that $\{M_1, \dots, M_N\} \subset \{Q_i, \dots, Q_k\}$. \square

We note that cover times are simply the lengths of consecutive disjoint covering sequences. We can now state the notion of a.s. covering protocols introduced in [21].

Definition 3 (A.s. covering protocol) A stochastic protocol is *a.s. covering* if $\mathbb{P}\{T_k < \infty\} = 1, \forall k \geq 0$, with T_k as per Definition 1. \square

An a.s. covering protocol grants network access to every node—at least once—within a finite number of transmissions with probability one. We emphasise that the stochastic protocol (6) considered in this paper is a.s. covering provided the probabilities of success p_j are not equal to zero.

To show stability under stochastic protocols, we first need to study the probability distribution of the cover times T_k . To that end, it is important to characterise $\mathbb{E}\{T_k\}$ and also its probability generating function (p.g.f.) $G_T(s) := \mathbb{E}\{s^T\}$, for $s \in \mathbb{R}$. Both are presented in the lemma below.

Lemma 1 Let T be the cover time for the sequence $\{(Q_0, \tau_0), \dots, (Q_{T-1}, \tau_{T-1})\}$. Then,

$$\mathbb{E}\{T\} = \sum_{j=1}^N \frac{N}{[N - (j-1)]p_j}, \quad (7)$$

$$G_T(s) = \prod_{j=1}^N \frac{s(N - (j-1))p_j}{N(1 - (1 - p_j)s) - s(j-1)p_j}, \quad (8)$$

for any $s \in \mathbb{R}$, with $|s| < \frac{1}{1 - [\min_{j \in \mathcal{N}} p_j(N - j + 1)]/N}$.

Proof: Let $j \in \mathcal{N}$, and \bar{t}_j be the additional number of transmissions required to go from $j-1$ to j different nodes being covered. Therefore, \bar{t}_j is geometrically distributed with parameter $[N - (j-1)]p_j/N$, and T can be written as $T = \sum_{j=1}^N \bar{t}_j$. Then, by linearity of expectation and since $\{Q_k\}_{k \in \mathbb{N}}$ are i.i.d. according to Assumption 2, we have $\mathbb{E}\{T\} = \mathbb{E}\left\{\sum_{j=1}^N \bar{t}_j\right\} = \sum_{j=1}^N \mathbb{E}\{\bar{t}_j\} = \sum_{j=1}^N N/((N - (j-1))p_j)$, which corresponds to (7). We now prove (8), $G_T(s) := \mathbb{E}\{s^T\} = \mathbb{E}\{s^{\bar{t}_1 + \dots + \bar{t}_N}\} = \prod_{j=1}^N \mathbb{E}\{s^{\bar{t}_j}\}$, for any $s \in \mathbb{R}$, where $\mathbb{E}\{s^{\bar{t}_j}\}$ corresponds to the p.g.f. $G_{\bar{t}_j}(s)$. Since \bar{t}_j is geometric, it is well known that $G_{\bar{t}_j}(s) = \frac{s\bar{p}}{1 - s(1 - \bar{p})}$ [53], for $|s| < 1/(1 - \bar{p})$, where \bar{p} is the parameter of the geometric variable \bar{t}_j , which is $\bar{p} = [N - (j-1)]p_j/N$ as stated above. With the latter, (8) follows immediately. \blacksquare

We note that $\mathbb{E}\{T\}$ represents the expected number of transmissions in which all matrices M_1, \dots, M_N have been covered at least once. We see in (7) that it depends on the probability of success p_j of each node $j \in \mathcal{N}$. This is different to previous works like [21, 41] in which $\mathbb{E}\{T\}$ only depends on a single probability of success. Moreover, the expectation $\mathbb{E}\{T\}$ was computed based on our assumptions for packet losses and scheduling protocol. In fact, different models for packet losses, and different contention mechanisms will lead to different expressions for $\mathbb{E}\{T\}$. We illustrate further below in Section 3.2 that this expected cover time plays a key role in stability. Future work includes the choice of more realistic channel models, e.g., Gilbert-Elliott channels [48], and CSMA protocols with random waits [54], where a node waits for a while (e.g., for an acknowledgement packet) after transmitting.

$$f_\chi(\chi, z, e, u, v, w) := f_p(\chi + g_o(z), u, w) - \frac{\partial g_o}{\partial z} f_o(z, u + e^u, g(\chi + g_o(z)) + v - g(g_o(z)) + e^y - e^{yz}), \quad (10a)$$

$$f_z(\chi, z, e, u, v) := f_o(z, u + e^u, g(\chi + g_o(z)) + v - g(g_o(z)) + e^y - e^{yz}), \quad (10b)$$

$$g_e(\chi, z, e, u, v, w, d) := \left(-\frac{\partial g}{\partial x_p} f_p(\chi + g_o(z), u, w) - d_v + \frac{\partial g}{\partial \bar{x}_p} \frac{\partial g_o}{\partial z} f_o(z, u + e^u, g(\chi + g_o(z)) + v - g(g_o(z)) + e^y - e^{yz}), -d_u \right). \quad (10c)$$

3 Input-to-state stability

In this section, we first provide a stochastic hybrid model for the overall WNCS in Figure 1, and then we use it to provide a sufficient condition on the rate of transmission that ensures a DISS property on the corresponding estimation error system. This sufficient condition translates into a bound on the transmission rate under which, in absence of inputs, the mean of the estimation error converges to zero.

3.1 A hybrid model for the WNCS

Given the continuous dynamics from the plant/controller, and the discrete dynamics introduced by transmissions and packet losses, we model the WNCS in Fig. 1 as a hybrid system. We introduce the estimation error $\chi := x_p - \tilde{x}_p$, and $d := (d_u, d_v)$, where $d_u := \dot{u}$ and $d_v := \dot{v}$. Then, by using the system description in Section 2, we can write

$$\dot{\chi} = f_\chi(\chi, z, e, u, v, w), \quad \forall t \in [t_k, t_{k+1}], \quad (9a)$$

$$\dot{z} = f_z(\chi, z, e, u, v), \quad \forall t \in [t_k, t_{k+1}], \quad (9b)$$

$$\dot{e} = g_e(\chi, z, e, u, v, w, d), \quad \forall t \in [t_k, t_{k+1}], \quad (9c)$$

$$\chi(t_k^+) = \chi(t_k), \quad (9d)$$

$$z(t_k^+) = z(t_k), \quad (9e)$$

$$e(t_k^+) = Q_k e(t_k), \quad (9f)$$

where f_χ , f_z and g_e are defined in (10). The model (9) captures all dynamics of the elements in the WNCS from Fig. 1 both between- and at-transmission instants. It is important to mention that (9) is a stochastic hybrid system (SHS), see e.g., [55]. Particularly, we emphasise that it is only the network-induced constraints (i.e., stochastic protocol, random transmissions, and random dropouts) that introduce randomness in our models, and the exogenous disturbances u , v , and w are \mathcal{L}_∞ signals as stated in Section 2. This leads to randomness in the jump equation (9f) and the transmission instants t_k . For detailed information about construction of solutions to the SHS (9), we refer the reader to [21], see also [55, 56]. At a general level, we flow the continuous dynamics until a discrete event occurs (or the end of the solution domain is reached), and then repeat from the new state after the jump. That is, let $\xi := (\chi, z, e)$, $\varpi := (u, v, w, d)$, $f_\xi := (f_\chi, f_z, g_e)$, and $J_k := \text{diag}\{I_{n_x}, I_{n_z}, Q_k\}$. With these definitions, the SHS (9) can be written as $\dot{\xi} = f_\xi(\xi, \varpi)$ for all $t \in [t_k, t_{k+1}]$, and $\xi(t_k^+) = J_k \xi(t_k)$. Let $t_0 \geq 0$ be the initial time. We assume enough regularity on f_ξ for the existence of an absolutely continuous function $\xi(t, t_0, \xi_0, \varpi)$ such that $\xi(t_0) = \xi_0$ and $(d/dt)\xi(t, t_0, \xi_0, \varpi) = f_\xi(\xi, \varpi)$, $t \in (t_0, a)$, $a > 0$, for every initial condition (t_0, ξ_0) and any $\varpi \in \mathcal{L}_\infty$. Then, the solutions to (9) are generated, for every (t_0, ξ_0) , as $\xi(t) = \xi_0 + \int_{t_0}^t f_\xi(s, \xi(s), \varpi(s)) ds$, $t \in (t_0, t_1)$, where $\xi(s) = \xi(s, t_0, \xi_0, \varpi(s))$, and inductively, for all $t \in (t_k, t_{k+1})$, $k \geq 1$, $\xi(t) = J_k \xi(t_k) + \int_{t_k}^t f_\xi(s, \xi(s), \varpi(s)) ds$, where $\xi(s) = \xi(s, t_k, J_k \xi(t_k), \varpi(s))$.

We are interested in different properties for the χ -system and the z -system. In particular, we want to prove a convergence property for the estimation error χ , but only some well defined or bounded behaviour for all time is desired for the observer state z .

3.2 Stability analysis

We now use the WNCs model (9) to provide sufficient conditions that guarantee a DISS stability property in expectation for the estimation error system. First, we state the underlying assumptions. Since the z -dynamics of the observer do not necessarily have to converge, we ensure they possess an appropriate (average) behaviour in the sense of no finite escapes for bounded inputs as per the below assumption.

Assumption 1 System $\dot{z} = f_z(\chi, z, e, u, v)$ is forward complete in expectation with inputs $(\chi, e) \in \mathcal{L}_\infty^e$ and $(u, v) \in \mathcal{L}_\infty$. That is, there exist $\nu_1, \nu_2, \nu_3 \in \mathcal{K}$ and $c \in \mathbb{R}_{\geq 0}$ such that, for any $z_0 \in \mathbb{R}^{n_z}$, $(\chi, e) \in \mathcal{L}_\infty^e$ and $(u, v) \in \mathcal{L}_\infty$, the corresponding solution to $\dot{z} = f_z(\chi, z, e, u, v)$ satisfies

$$\mathbb{E}\{|z(t)|\} \leq \nu_1(t) + \nu_2(|z_0|) + \nu_3(\mathbb{E}\{\|\chi, e, u, v\|_{\mathcal{L}_\infty[0,t]}\}) + c,$$

for all $t \geq 0$ □

We highlight that Assumption 1 is inspired on the influential characterisations proposed by Angeli and Sontag in [8], where they show forward completeness can be characterised in a necessary and sufficient manner by means of smooth scalar growth inequalities.

We next assume a specific grow for the e -system (9c) between two successive transmissions.

Assumption 2

(a) There exists an $n \times n$ real matrix A with non-negative entries and a continuous function $\tilde{y} : \mathbb{R}^{n_x} \times \mathbb{R}^{n_z} \times \mathbb{R}^{n_u} \times \mathbb{R}^{n_v} \times \mathbb{R}^{n_w} \times \mathbb{R}^{n_u+n_v} \rightarrow \mathbb{R}_{\geq 0}^n$ such that

$$\bar{g}_e(\chi, z, e, u, v, w, d) \preceq A\bar{e} + \tilde{y}(\chi, z, u, v, w, d), \quad (11)$$

for all $\chi \in \mathbb{R}^{n_x}$, $z \in \mathbb{R}^{n_z}$, $e \in \mathbb{R}^n$, $u \in \mathbb{R}^{n_u}$, $v \in \mathbb{R}^{n_v}$, $w \in \mathbb{R}^{n_w}$, and $d \in \mathbb{R}^{n_u+n_v}$.

(b) There exists $\gamma_2^\chi \in \mathbb{R}_{\geq 0}$ and $\sigma \in \mathcal{K}_\infty$ such that \tilde{y} in (11) satisfies $|\tilde{y}(\chi, z, u, v, w, d)| \leq \gamma_2^\chi |\chi| + \sigma(\|(u, v, w, d)\|)$, for all $\chi \in \mathbb{R}^{n_x}$, $z \in \mathbb{R}^{n_z}$, $u \in \mathbb{R}^{n_u}$, $v \in \mathbb{R}^{n_v}$, $w \in \mathbb{R}^{n_w}$, and $d \in \mathbb{R}^{n_u+n_v}$. □

Assumption 2(a) is the vector analogue of the standard dissipation-type inequalities often adopted for the e -dynamics in controller and observer design, see e.g., [16, 42]. Assumption 2(b) imposes a linear gain with respect to χ , and it is reminiscent of condition (13) in [16]. We assume the upper bound on $|\tilde{y}|$ to be independent of z in this paper. However, this can be relaxed as done in our previous deterministic work [40], at the expense of getting weaker stability properties. To avoid obscuring the main message of this paper, we adopt Assumption 2(b), as this already holds for a large class of observers, see the example in Section 4 for instance. Lastly, we assume the observer (2) is designed appropriately so that the estimation error converges in absence of external disturbances, noise, and network.

Assumption 3 There exists $\beta_1 \in \mathcal{KL}$, $\gamma_1^e \in \mathbb{R}_{\geq 0}$ and $\mu \in \mathcal{K}_\infty$ such that, for any $\chi_0 \in \mathbb{R}^{n_x}$, $e \in \mathcal{L}_\infty^e$ and $(v, w) \in \mathcal{L}_\infty$, the corresponding solution to $(\dot{\chi}, \dot{z}) = (f_\chi(\chi, z, e, u, v, w), f_z(\chi, z, e, u, v))$ satisfies

$$\begin{aligned} \mathbb{E}\{|\chi(t)|\} &\leq \beta_1(|\chi_0|, t) + \gamma_1^e \mathbb{E}\{\|e\|_{\mathcal{L}_\infty[0,t]}\} + \mu(\|(v, w)\|_{\mathcal{L}_\infty[0,t]}), \\ \mathbb{E}\{\|\chi\|_{\mathcal{L}_\infty[0,t]}\} &\leq \beta_1(|\chi_0|, 0) + \gamma_1^e \mathbb{E}\{\|e\|_{\mathcal{L}_\infty[0,t]}\} + \mu(\|(v, w)\|_{\mathcal{L}_\infty[0,t]}), \end{aligned}$$

for all $t \geq 0$. □

We note that Assumption 3 ensures an ISS property on the designed observer so that it is robust with respect to (e, v, w) , which is satisfied by various observer designs in the literature, see e.g., [57, 58] and the references therein. These ISS conditions are the stochastic counterpart of the ones often adopted when using emulation-based design, see e.g., [14, 40]. Similar stochastic ISS notions have been used in the literature, see e.g., [59]. We note the above assumptions hold in different scenarios such as high-gain and circle criterion observers, and we illustrate this via an example in Section 4, see also [57].

We are now ready to state the main stability results. Essentially, we consider system (9) as the interconnection of three subsystems in χ , z and e , and apply small-gain arguments to conclude a DISS stability property for the overall system. Given Assumptions 1–3, the stability of χ - and e -dynamics can be studied separately from the system interconnection (9). We first show that the e -subsystem satisfies an ISS property with respect to \tilde{y} .

Proposition 2 *Suppose Assumption 2(a) holds. Under the stochastic protocol in Section 2.3, there exists a rate of transmission λ that satisfies $\rho(\lambda) < 1$, where*

$$\rho(\lambda) := \prod_{j=1}^N \frac{(N-(j-1)p_j)}{N(1-|A|/\lambda-(1-p_j))-(j-1)p_j} - 1, \quad \lambda > N|A|/[\min_{j \in \mathcal{N}} p_j(N-j+1)], \quad (12)$$

for which there exists $\beta_2 \in \mathcal{KL}$ such that any solution to the e -subsystem (9c), (9f) with initial condition $e_0 \in \mathbb{R}^n$ and input $\tilde{y} \in \mathcal{L}_\infty^e$ verifies

$$\mathbb{E}\{|e(t)|\} \leq \beta_2(|e_0|, t) + \tilde{\gamma}(\lambda)\mathbb{E}\{\|\tilde{y}\|_{\mathcal{L}_\infty[0,t]}\}, \quad (13)$$

for all $t \geq 0$, with¹

$$\tilde{\gamma}(\lambda) = \frac{\mathbb{E}\{T\}(1 + \rho(\lambda))}{(\lambda - |A|)(1 - \rho(\lambda))}. \quad (14)$$

Proof: See Section 6.1. ■

We note that $\mathbb{E}\{T\}$ is computed as per Lemma 1, and it depends on the success probabilities for each node. It is important to highlight that our results are general in the sense that they depend on the expected cover time, and the expression for it depends on the implemented protocol. In this setting, $\mathbb{E}\{T\}$ can be computed explicitly for the considered stochastic protocol and packet loss model by Lemma 1. However, these results provide a foundation for more general settings with different packet loss models such as the Gilbert-Elliott model [48], where the computation of $\mathbb{E}\{T\}$ would lead to a different expression than (7).

Proposition 2 provides sufficient conditions on the arrival rate λ so that the e -subsystem is ISS w.r.t. \tilde{y} . Since the emulation design ensures ISS properties on the χ -subsystem by means of Assumption 3, and the z -dynamics behave nicely via Assumption 1, we can now state a DISS property for the overall system (9) via a small-gain theorem.

Theorem 3 *Suppose Assumptions 1–3 hold. Then, there exists $\lambda^* \in (0, \infty)$ that solves $\tilde{\gamma}(\lambda^*)\gamma_2^x\gamma_1^e = 1$, and for any choice of intensity of transmission satisfying $\lambda > \lambda^*$, the following holds.*

(i) *There exist $\beta \in \mathcal{KL}$, $\eta_1 \in \mathcal{K}$, and $\eta_2 \in \mathcal{KK}$ such that*

$$\mathbb{E}\{|(\chi(t), e(t))|\} \leq \beta(|(\chi_0, e_0)|, t) + \eta_1(\|(v, w)\|_{\mathcal{L}_\infty}) + \eta_2(1/\lambda, \|(u, v, w, d)\|_{\mathcal{L}_\infty}), \quad (15)$$

for all $(\chi_0, e_0) \in \mathbb{R}^{n_x+n}$, $(u, v, w, d) \in \mathcal{L}_\infty$, and $t \geq 0$.

(ii) *System (9) is forward complete in expectation with input $(u, v, w, d) \in \mathcal{L}_\infty$.*

Proof: See Section 6.2. ■

Theorem 3 shows that the expectations of both the estimation error χ and the network-induced error e converge to a ball centred at the origin, and whose radius depends on the \mathcal{L}_∞ norm of the input (u, v, w, d) . This is a DISS property for the (χ, e) -subsystem with respect to the inputs (u, v, w, d) , for which we can draw some interesting conclusions. When disturbances and measurement noises are absent, i.e., $w = 0$ and $v = 0$, the mean of the estimation error—a *priori*—does not converge to the origin, since in this case, $\mathbb{E}\{|(\chi(t), e(t))|\} \leq \beta(|(\chi_0, e_0)|, t) + \eta_2(1/\lambda, \|(u, d_u)\|_{\mathcal{L}_\infty})$. However, we can always increase the intensity of transmission λ so that η_2 is small, and thus the effect of (u, d_u) is reduced. Moreover, we note that the dependence on u in (15) comes from the definition of g_e in (10c) and Assumption 2(b). For different scenarios, which our setting already covers, the dependence on (u, d_u) may be completely removed. For instance, in WNCSS where the observer is collocated in the same remote unit with the controller, the observer has direct access to u (rather than \hat{u}), i.e., $e^u = 0$. Then σ in Assumption 2(b) would not depend on u for a large class of systems, e.g., input affine non-linear systems and observers that run a copy of the plant. We show an example in Section 4 below (see (18a),(18c) with $e^u = 0$). Lastly, we note that in absence of inputs, i.e., $w = v = u = 0$, the mean of the estimation error indeed asymptotically converges to the origin in (15).

4 Case study: Circle criterion observer

We highlight that the results in Section 3 apply to numerous different observers, including but not limited to, high-gain observers, circle criterion observers, and globally Lipschitz observers,

¹Note that the right-hand side inequality in (12) implies $\lambda > |A|$, more details in the proof in Section 6.1.

see e.g., [60–62]. We next apply our results to circle criterion observers as an example [61, 63]. Consider that plant (1) takes the form

$$\dot{x}_p = A_p x_p + G\psi(Hx_p) + \phi(u) + w, \quad y = Cx_p + v, \quad (16)$$

where $x_p \in \mathbb{R}^{n_x}$, $y \in \mathbb{R}^{n_y}$, $u \in \mathbb{R}^{n_u}$, A_p, G, H and C are matrices of appropriate dimensions. The state dependent non-linearity ψ is an r -dimensional vector where each entry is a function of a linear combination of the states $\psi_i = \psi_i\left(\sum_{j=1}^{n_x} H_{ij}x_{p,j}\right)$, $i = 1, \dots, r$. The main restriction is that each ψ_i is non-decreasing, that is, for all $a, b \in \mathbb{R}$, it satisfies $(a - b)[\psi_i(a) - \psi_i(b)] \geq 0$. The class of non-linearities for which the circle criterion results in [61, 63] apply, is a large class that does not require globally Lipschitzness of ψ and ϕ . In this case study, however, we assume ψ and ϕ are globally Lipschitz with constants Ψ and Φ , respectively. The observer for system (16) is given by

$$\dot{z} = A_p z + L(y_z - y) + G\psi(Hz + K(y_z - y)) + \phi(u), \quad y_z = Cz, \quad (17)$$

where $z = \tilde{x}_p \in \mathbb{R}^{n_x}$, $K \in \mathbb{R}^{r \times n_y}$, and $L \in \mathbb{R}^{n_x \times n_y}$ are such that the following holds.

Assumption 4 There exist $K, L \in \mathbb{R}^{n_x \times n_y}$, and a real symmetric positive definite matrix $P \in \mathbb{R}^{n_x \times n_x}$ such that for $V : \chi \mapsto \chi^\top P \chi$,

$$\langle \nabla V(\chi), (A_p + LC)\chi + G\psi(H(\chi + z)) - G\psi(Hz - KC\chi) \rangle \leq -cV(\chi),$$

for all $\chi \in \mathbb{R}^{n_x}$, $z \in \mathbb{R}^{n_y}$, and some $c \in \mathbb{R}_{>0}$. \square

Finding K and L such that Assumption 4 is satisfied can be done via solving an LMI [63]. After implementing the observer (17) over the wireless network, we can write

$$f_\chi(\chi, z, e, u, v, w) = (A_p + LC)\chi + \phi(u) - \phi(u + e^u) + L(e^y - e^{y_z} + v) + w + G\psi(H(\chi + z)) - G\psi(Hz - KC\chi - Kv - K(e^y - e^{y_z})), \quad (18a)$$

$$f_z(\chi, z, e, u, v) = A_p z - L(C\chi + e^y - e^{y_z} + v) + G\psi(Hz - K(C\chi + e^y - e^{y_z} + v)) + \phi(u + e^u) \quad (18b)$$

$$g_e(\chi, z, e, u, v, w, d) = (-Cf_\chi(\chi, z, e, u, v, w) - d_v, -d_u). \quad (18c)$$

We next verify that Assumptions 2–3 hold, as formalised in the proposition below.

Proposition 4 Consider system (9) with f_χ, f_z and g_e as per (18). Under the stochastic protocol in Section 2.3 and Assumption 4, the following holds.

(i) Assumption 2(a) holds with

$$A = \begin{bmatrix} \overline{CL} + \Psi|K|\overline{CG}\mathbf{1}_{r \times n_y} & \Phi\overline{C}\mathbf{1}_{n_x \times n_u} \\ 0 & 0 \end{bmatrix}, \quad (19)$$

and

$$\tilde{y}(\chi, z, u, v, w, d) = \begin{bmatrix} \overline{C(A_p + LC)\chi} + \Psi\overline{CG}|(H + KC)\chi + Kv|\mathbf{1}_r + \overline{CLv} + \overline{Cw} + \overline{d_v} \\ \overline{d_u} \end{bmatrix}. \quad (20)$$

(ii) Assumption 2(b) holds with $\gamma_2^\chi = |C(A_p + LC)| + \Psi|CG|\mathbf{1}_r\|H + KC|$ and $\sigma(s) = \max\{\Psi|CG|\|K\|\mathbf{1}_r + |CL|, |C|, 1\}4s$.

(iii) Assumption 3 holds with $\beta_1(s, t) = \sqrt{\lambda_{\max}(P)/\lambda_{\min}(P)}\exp(-ct/10)s$, $\gamma_1^e = \max\left\{\frac{5(\Psi|PG|\|K\| + |PL|)}{c\lambda_{\min}(P)}, \frac{5\Phi|P|}{c\lambda_{\min}(P)}\right\}$, and $\mu(s) = \max\left\{\frac{5(\|K\| + |PL|)}{c\lambda_{\min}(P)}, \frac{5|P|}{c\lambda_{\min}(P)}\right\}2s$, where P and c come from Assumption 4.

Proof: See Section 6.3. \blacksquare

Note that, since ψ and ϕ in (17) are globally Lipschitz, Assumption 1 always applies in view of, e.g., [64, Theorem 3.2]. Then, a direct consequence of Proposition 4 is that all conditions of Theorem 3 are satisfied. Moreover, all parameters needed to calculate the transmission rate bound are given in Proposition 4. Hence, Theorem 3 can be directly applied. This is formalised via the following corollary.

Corollary 5 Consider system (9) with f_x, f_z and g_e as per (18), under the stochastic protocol in Section 2.3. Suppose Assumption 4 holds. Then, for any choice of transmission rate $\lambda > \lambda^*$, where λ^* solves $\tilde{\gamma}(\lambda^*)\gamma_2^x\gamma_1^e = 1$ with $\tilde{\gamma}$ as per (14), we have that (15) holds. ■

5 Numerical simulations

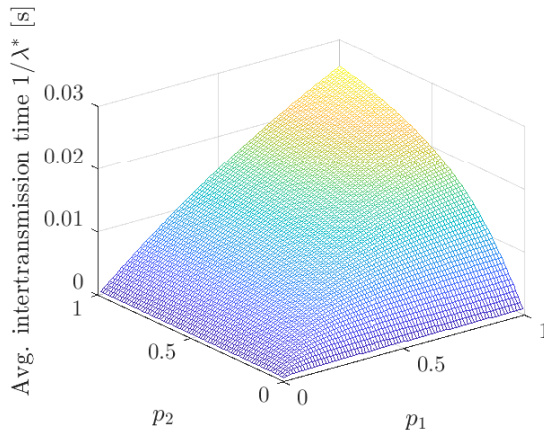

Fig. 2 Average inter-transmission times $1/\lambda^*$ (in seconds) for different probabilities of successful transmission in nodes 1 and 2.

We now numerically illustrate our results for the case study in Section 4. Consider the plant (16) with

$$A_p = \begin{bmatrix} 0 & 1 & 0 \\ 0 & 1 & 1 \\ 0 & 0 & 0 \end{bmatrix}, \quad G = \begin{bmatrix} 1 \\ -1 \\ 0 \end{bmatrix}, \quad H = [0 \ 1 \ 0], \quad C = [1 \ 0 \ 0],$$

and $\psi(Hx_p) = \psi(x_{p,2}) = \sqrt{x_{p,2}^2 + 5}$, $\phi(u) = (0, u, 2u)$, and $w = 0, v = 0$. Note that ψ and ϕ are globally Lipschitz with constants $\Psi = 1$ and $\Phi = \sqrt{5}$. To design the observer (17), in absence of the network, we solve the LMI in [63, Theorem 5.1] to find K and L that verify Assumption 4. Particularly, we get

$$P = \begin{bmatrix} 2.62 & -0.64 & -0.23 \\ -0.64 & 0.36 & -0.23 \\ -0.23 & -0.23 & 1.65 \end{bmatrix}, \quad K = -3.26, \quad L = \begin{bmatrix} -3.8 \\ -13.64 \\ -1.99 \end{bmatrix}, \quad c = 0.082.$$

As per emulation, the observer is implemented over a wireless network consisting of two nodes ($N = 2$), one for the sensor measurement y and another for the control input u . The probabilities of successful transmission for nodes 1 and 2 are denoted by p_1 and p_2 , respectively. We now compute the transmission rate bound λ^* for which any $\lambda > \lambda^*$ ensures the DISS property (15) on the estimation error. We do this via Corollary 5, and the parameters required to compute it are obtained via Proposition 4. That is, $A = \begin{bmatrix} 7.06 & 2.24 \\ 0 & 0 \end{bmatrix}$, $\gamma_2^x = 7.35$, $\gamma_1^e = 5.92 \cdot 10^3$.

In Figure 2, we depict the stability region for which the DISS property (15) on the estimation error system holds. Specifically, we have plotted the average inter-transmission times $\bar{\tau} = 1/\lambda^*$ for different values of the probabilities of success in nodes 1 and 2. Any values of $\bar{\tau}$ below the curve plotted in Figure 2 satisfies the stability property (15). We can see an overall trend in which lower probabilities of success require faster transmissions to have effective estimation. Even if one channel is high quality, a second channel with several dropouts may still require a high rate of transmission to ensure good estimation.

In brief, our results state that, if we—for instance—pick $p_1 = 0.5$ and $p_2 = 0.8$ (i.e., an average of 50% packet loss for node 1 and 20% for node 2), we need to transmit every $\bar{\tau} = 14$ [ms], on

average, to ensure our state estimation approximates the state of the plant (16) on average, when using a random access wireless network.

6 Proof of main results

6.1 Proof of Proposition 2

The proof is divided in two steps. We first show that there exists a choice of intensity of transmission λ that satisfies $\rho(\lambda) < 1$. The second step consists on showing that (13) holds for such choice of λ . The first step follows from noting that $\rho(\lambda) > 0$ is a strictly decreasing function of λ for $\lambda > 0$, and that $\lim_{\lambda \rightarrow \infty} \rho(\lambda) = 0$, which implies $\exists \lambda_e^* \in (0, \infty)$ such that for all $\lambda > \lambda_e^*$, $\rho(\lambda) < 1$.

Let us now fix some λ such that $\rho(\lambda) < 1$. We will show that the e -subsystem (9c), (9f) is ISS in expectation from \tilde{y} to e , i.e., that (13) holds for all $t \geq 0$. To that end, let us first introduce the following technical lemma.

Lemma 6 *Let T be the cover time for the sequence $\{(Q_0, \tau_0), \dots, (Q_{T-1}, \tau_{T-1})\}$. Then, the following holds.*

- (a) $|\prod_{k=0}^{T-1} Q_k \exp(A\tau_k)| \leq \exp(|A| \sum_{k=0}^{T-1} \tau_k) - 1$.
 (b) $\mathbb{E}\{\exp(|A| \sum_{k=0}^{T-1} \tau_k)\} = \rho(\lambda) + 1$, with ρ as per (12).

Proof: Item (a) follows immediately from [21, Lemma 9.1]. (b) Let $\tilde{\tau} = \sum_{k=0}^{T-1} \tau_k$. Via Example 1.8.13 in [53], we can compute the moment generating function of S as $M_{\tilde{\tau}}(s) = \mathbb{E}\{\exp(s\tilde{\tau})\} = G_T(M_{\tau}(s))$, where M_{τ} is the moment generating function of the exponentially distributed random variables τ_k . Particularly, $M_{\tau}(s) = \lambda/(\lambda - s)$, for $\lambda > s$. Therefore, $\mathbb{E}\{\exp(|A|\tilde{\tau})\} = G_T(\lambda/(\lambda - |A|))$, where $G_T(s)$ is given in Lemma 1, and we require both $\lambda/(\lambda - |A|) < \frac{1}{1 - [\min_{j \in \mathcal{N}} p_j(N - j + 1)]/N}$ and $\lambda > |A|$. The proof is complete by noting that choosing λ as per the proposition statement satisfies both bounds. Particularly, note that it suffices to show that $\min_{j \in \mathcal{N}} p_j(N - j + 1)/N \leq 1$. In fact, $\min_{j \in \mathcal{N}} p_j(N - j + 1)/N = \min\{p_1, p_2(N - 1)/N, \dots, p_N/N\}$, which is always less or equal than 1 since $p_j \in (0, 1]$ for all $j \in \mathcal{N}$, and $N > 0$. Then, (12) implies $\lambda > |A|$. ■

We now proceed to show (13). Let e be a solution to (9c), (9f) with input $\tilde{y} \in \mathcal{L}_{\infty}^e$. To prove (13), we first compute the contribution of the initial condition e_0 , and then the contribution of the input \tilde{y} . Consequently, let $\tilde{y} = 0$. Similar to the proof of Theorem 9.4 in [21], from Assumption 2(a) and (9f), we can write $\bar{e}(t_k^+) \preceq Q_k \exp(A(t_k - t_{k-1}))\bar{e}(t_{k-1}^+) \preceq Q_k \exp(A\tau_k)\bar{e}(t_{k-1}^+)$ for all $k \in \mathbb{N}$. Iterating the latter leads to

$$\bar{e}(t_k^+) = \left(\prod_{i=0}^k Q_i \exp(A\tau_i) \right) \bar{e}_0. \quad (21)$$

We now introduce some needed definitions. Let the sequence $\{(Q_0, \tau_0), (Q_1, \tau_1), \dots\}$ be partitioned such that each subsequence $\{(Q_0, \tau_0), \dots, (Q_{T_0-1}, \tau_{T_0-1})\} \cup \{(Q_{T_0}, \tau_{T_0}), \dots, (Q_{T_0+T_1-1}, \tau_{T_0+T_1-1})\}, \dots$ is covering, and let T_j denote the cover time for the j -th subsequence, $j \in \mathbb{N}$. Let $\rho_j := \exp(|A| \sum_{i=0}^{T_j-1} \tau_{j,i}) - 1$, where $\tau_{j,i}$ denotes the i -th inter-transmission time in the j -th covering sequence. Let S_M be the time it takes to cover N nodes M times, i.e., $S_M := \sum_{j=0}^{M-1} \sum_{i=0}^{T_j-1} \tau_{j,i}$. Lastly, we define a process $r_T(t) := \max\{M \geq 0 : t \geq S_M\} =: \max \mathcal{M}(t)$. We note that $r_T(t)$ counts the amount of times N nodes have been visited. Particularly, $r_T(t)$ is a renewal process² [53], i.e., a more general notion than the Poisson process $r(t)$ that governs transmissions in Assumption 1, since the holding times $S_{M+1} - S_M = \sum_{i=0}^{T_M-1} \tau_{M,i}$ are not necessarily exponentially distributed.

²It suffices to verify that the holding times $S_{M+1} - S_M$ are i.i.d. and have positive finite mean. Since T_k 's and τ_k 's are i.i.d., then the holding time $S_{M+1} - S_M$ is also i.i.d.. Next, we have $\mathbb{E}\{S_{M+1} - S_M\} = \mathbb{E}\{T_M\} \mathbb{E}\{\tau_{M,i}\}$. Particularly, $\mathbb{E}\{\tau_{M,i}\} = 1/\lambda$, and $\mathbb{E}\{T_M\}$ can be found in Lemma 1. Consequently, $\mathbb{E}\{S_{M+1} - S_M\} = \frac{1}{\lambda} \sum_{j=1}^N \frac{N}{[N - (j-1)]p_j}$, which is positive and finite since $p_j \in (0, 1]$ for all $j \in \mathcal{N}$, $\lambda \in (0, \infty)$, and $N \geq 1$.

From (21), the above definitions, and Lemma 6(a), we can write

$$|\bar{e}(S_M^+)| \leq \left| \prod_{t_k \leq S_M} Q_k \exp(A\tau_k) \right| |\bar{e}_0| \leq \left(\prod_{j=0}^{M-1} \rho_j \right) |\bar{e}_0|.$$

Moreover, from Assumption 2(a) with $\tilde{y} = 0$, we can further write, for all $t \in (S_M, S_{M+1})$ and $M \in \mathbb{N}_{>0}$,

$$|e(t)| \leq \left(\prod_{j=0}^{M-1} \rho_j \right) \exp(|A|(t - S_M)) |e_0| \leq \left(\prod_{j=0}^{M-1} \rho_j \right) (\rho_M + 1) |e_0|, \quad (22)$$

where the latter comes from the definition of ρ_M , and noting that $|\bar{e}| = |e|$.

We now show that we can relate M with the renewal process $r_T(t)$, and thus write (22) in terms of $r_T(t)$ for all $t \geq 0$. For the next part of the proof we will include the sample space Ω explicitly for formality, but when omitted it will be clear from the context. Fix $t \geq 0$, then, for almost every (a.e.) realisation $\omega \in \Omega$, since $S_M(\omega) \rightarrow \infty$ when $M \rightarrow \infty$, $\exists M(\omega)$ such that $t \in (S_{M(\omega)}, S_{M(\omega)+1})$ a.s.. Then, by definition of $r_T(\omega, t)$, $M(\omega) = r_T(\omega, t)$ in such interval. Therefore, since the above argument can be done for any $t \geq 0$, from (22) we can write

$$|e(\omega, t)| \leq \left(\prod_{j=0}^{r_T(\omega, t)-1} \rho_j \right) (\rho_{r_T(\omega, t)} + 1) |e_0|, \quad (23)$$

for all $t \geq 0$. That is, for each realisation $\omega \in \Omega$, the network-induced error satisfies (23) for all $t \geq 0$ almost surely.

We apply the law of total expectation in (23), together with Lemma 6(b), to obtain $\mathbb{E}\{|e(\omega, t)|\} \leq \mathbb{E}\{\rho^{r_T(\omega, t)}\} (\rho + 1) |e_0|$, $\forall t \geq 0$, where $\rho < 1$ is as per the proposition statement. In what follows, we prove that $\beta_2(s, t) := \mathbb{E}\{\rho^{r_T(t)}\} (\rho + 1)s$, exists and is a \mathcal{KL} function. Since our stochastic protocol is a.s. covering, the holding times are finite with probability one, and thus $r_T(t)$ grows unbounded in t , i.e., $\lim_{t \rightarrow \infty} r_T(t) = \infty$ (see e.g., Lemma 18 in [53]). Moreover, $\mathbb{E}\{\rho^{r_T(t)}\} = \sum_{k=0}^{\infty} \rho^k \mathbb{P}\{r_T(t) = k\} \leq \sum_{k=0}^{\infty} \rho^k = 1/(1 - \rho) < \infty$, since $\rho < 1$. Then, we know $\mathbb{E}\{\rho^{r_T(t)}\}$ exists and it is bounded. Therefore, $\beta_2(\cdot, t)$ is of class \mathcal{K} for each $t \geq 0$. It remains to show that $\beta(s, \cdot)$ is non-increasing and satisfies $\lim_{t \rightarrow \infty} \beta(s, t) = 0$ for each $s \geq 0$.

Non-increasing: We first need to show that, for a.e. $\omega \in \Omega$, $r_T(\omega, t)$ is a non-decreasing function of t . Let $0 \leq t_1 \leq t_2$, then $\exists M(\omega) \in \mathcal{M}(t_1)$ for which $t_1 \geq S_{M(\omega)}$, and thus $t_2 \geq t_1 \geq S_{M(\omega)}$. Then, $M(\omega) \in \mathcal{M}(t_2)$, meaning $\mathcal{M}(t_1) \subseteq \mathcal{M}(t_2)$, and thus $r_T(\omega, t_2) := \max \mathcal{M}(t_2) \geq \max \mathcal{M}(t_1) =: r_T(\omega, t_1)$, showing $r_T(\omega, t)$ is non-decreasing in $t \geq 0$. Next, we show $\beta_2(s, t)$ is non-increasing in t . That is, for $t_2 \geq t_1 \geq 0$ we just showed that $r_T(\omega, t_2) \geq r_T(\omega, t_1)$, and since $\rho < 1$, $\rho^{r_T(\omega, t_2)} \leq \rho^{r_T(\omega, t_1)}$. Lastly, by monotonicity of the expectation, $\mathbb{E}\{\rho^{r_T(\omega, t_2)}\} \leq \mathbb{E}\{\rho^{r_T(\omega, t_1)}\}$, showing that $\beta_2(s, t)$ is non-increasing in $t \geq 0$.

Limiting behaviour: First note that $\lim_{t \rightarrow \infty} \rho^{r_T(\omega, t)} = 0$, $\forall \omega \in \Omega$, since $\rho < 1$. Moreover, $|\rho^{r_T(\omega, t)}| \leq 1$, $\forall \omega \in \Omega, \forall t \geq 0$. Then, by the dominated convergence theorem (see [65, Sec. 5.9]), we have that $\lim_{t \rightarrow \infty} \mathbb{E}\{\rho^{r_T(t)}\} = 0$. We can thus conclude that, indeed, $\beta_2(s, t) = \mathbb{E}\{\rho^{r_T(t)}\} (\rho + 1)s \in \mathcal{KL}$.

So far we have shown the contribution of the initial condition e_0 in (13). It remains to show that $\mathbb{E}\{|e(t)|\} \leq \tilde{\gamma}(\boldsymbol{\lambda}) \mathbb{E}\{\|\tilde{y}\|_{\mathcal{L}_\infty[0, t]}\}$ to conclude the proof. We set the initial condition $e_0 = 0$ and compute the contribution of the input \tilde{y} directly by applying Theorem 9.4 in [21], which gives $\mathbb{E}\{\|e\|_{\mathcal{L}_\infty[0, t]}\} \leq \tilde{\gamma}(\boldsymbol{\lambda}) \mathbb{E}\{\|\tilde{y}\|_{\mathcal{L}_\infty[0, t]}\}$. Since $|e(t)| \leq \|e\|_{\mathcal{L}_\infty[0, t]}$ for all $t \geq 0$, the proof is thus complete. \blacksquare

6.2 Proof of Theorem 3

We first show that there exists $\boldsymbol{\lambda}^* \in (0, \infty)$ such that for all $\boldsymbol{\lambda} > \boldsymbol{\lambda}^*$, $\tilde{\gamma}(\boldsymbol{\lambda}) \gamma_2^X \gamma_1^e < 1$. Note that $\rho(\boldsymbol{\lambda})$ is a strictly decreasing function of $\boldsymbol{\lambda}$, then so is $\tilde{\gamma}$ in (14). Moreover, $\lim_{\boldsymbol{\lambda} \rightarrow \infty} \tilde{\gamma}(\boldsymbol{\lambda}) = 0$. This implies that there exists $\boldsymbol{\lambda}^* \in (0, \infty)$ such that $\tilde{\gamma}(\boldsymbol{\lambda}^*) \gamma_2^X \gamma_1^e = 1$, and particularly, for any $\boldsymbol{\lambda} > \boldsymbol{\lambda}^*$, $\tilde{\gamma}(\boldsymbol{\lambda}) \gamma_2^X \gamma_1^e < 1$, which will be required in the proof later on (small gain condition).

(i) Now we continue with proving (15). This part of the proof is inspired by the deterministic works [66, Theorem 2.1] and [16, Theorem 1], and it follows via two steps. In the first step,

we prove that (χ, e) -subsystem is bounded-input bounded-state (BIBS) in expectation with input (u, v, w, d) . That is, we show that there exists $\bar{\alpha}, \varphi \in \mathcal{K}$ such that $\mathbb{E}\{|\chi(t), e(t)|\} \leq \bar{\alpha}(|\chi_0, e_0|) + \varphi(\|(u, v, w, d)\|_{\mathcal{L}_\infty[0,t]})$, for all $t \geq 0$. In the second step, we show convergence in the sense of the DISS property (15).

Step 1 (BIBS property): From the proof of Theorem 9.4 in [21] (i.e., \mathcal{L}_p stability from \tilde{y} to e), and using similar arguments that led to (23), we have that, for any initial condition $e_0 \in \mathbb{R}^n$ and any exogenous input $\tilde{y} \in \mathcal{L}_\infty^e$, any corresponding solution to (9c), (9f) satisfies $\mathbb{E}\{\|e\|_{\mathcal{L}_\infty[0,t]}\} \leq \alpha(|e_0|) + \tilde{\gamma}(\boldsymbol{\lambda})\mathbb{E}\{\|\tilde{y}\|_{\mathcal{L}_\infty[0,t]}\}$ for all $t \geq 0$ with $\alpha(s) = \frac{1+\rho(\boldsymbol{\lambda})}{(1-\rho(\boldsymbol{\lambda}))^{\min\{|A|,1\}}}s$ and $\tilde{\gamma}$ as per (14). With the latter, and together with Assumptions 2(b) and 3, we can write

$$\begin{aligned} \mathbb{E}\{\|e\|_{\mathcal{L}_\infty[0,t]}\} &\leq \alpha(|e_0|) + \tilde{\gamma}(\boldsymbol{\lambda})\left(\gamma_2^x \mathbb{E}\{\|\chi\|_{\mathcal{L}_\infty[0,t]}\} + \sigma(\|(u, v, w, d)\|_{\mathcal{L}_\infty[0,t]})\right) \\ &\leq \frac{\alpha(|e_0|)}{1 - \tilde{\gamma}(\boldsymbol{\lambda})\gamma_2^x\gamma_1^e} + \frac{\tilde{\gamma}(\boldsymbol{\lambda})}{1 - \tilde{\gamma}(\boldsymbol{\lambda})\gamma_2^x\gamma_1^e} \left(\gamma_2^x\beta_1(|\chi_0|, 0) + \gamma_2^x\mu(\|(v, w)\|_{\mathcal{L}_\infty[0,t]})\right) \\ &\quad + \sigma(\|(u, v, w, d)\|_{\mathcal{L}_\infty[0,t]}) \\ &:= M_e(\boldsymbol{\lambda}, \chi_0, e_0, \|(u, v, w, d)\|_{\mathcal{L}_\infty[0,t]}). \end{aligned} \quad (24)$$

Similarly, from Assumption 3 and (24), we get

$$\begin{aligned} \mathbb{E}\{\|\chi\|_{\mathcal{L}_\infty[0,t]}\} &\leq \beta_1(|\chi_0|, 0) + \gamma_1^e M_e + \mu(\|(v, w)\|_{\mathcal{L}_\infty[0,t]}) \\ &:= M_\chi(\boldsymbol{\lambda}, \chi_0, e_0, \|(u, v, w, d)\|_{\mathcal{L}_\infty[0,t]}). \end{aligned} \quad (25)$$

Then, $\mathbb{E}\{|\chi(t), e(t)|\} \leq M_\chi + M_e$, for all $t \geq 0$, and thus

$$\begin{aligned} \mathbb{E}\{|\chi(t), e(t)|\} &\leq \bar{\alpha}(|\chi_0, e_0|) + \mu(\|(v, w)\|_{\mathcal{L}_\infty[0,t]}) + \varphi_1(1/\boldsymbol{\lambda})\mu(\|(v, w)\|_{\mathcal{L}_\infty[0,t]}) \\ &\quad + \varphi_2(1/\boldsymbol{\lambda})\sigma(\|(u, v, w, d)\|_{\mathcal{L}_\infty[0,t]}), \end{aligned} \quad (26)$$

for all $t \geq 0$, where $\bar{\alpha}(s) = \beta_1(s, 0) + \frac{(\gamma_1^e+1)}{1-\tilde{\gamma}(\boldsymbol{\lambda})\gamma_2^x\gamma_1^e}\alpha(s) + \frac{(\gamma_1^e+1)\tilde{\gamma}(\boldsymbol{\lambda})\gamma_2^x}{1-\tilde{\gamma}(\boldsymbol{\lambda})\gamma_2^x\gamma_1^e}\beta_1(s, 0)$, $\varphi_1(s) = \frac{(\gamma_1^e+1)\tilde{\gamma}(s^{-1})\gamma_2^x}{1-\tilde{\gamma}(s^{-1})\gamma_2^x\gamma_1^e}$, and $\varphi_2(s) = \frac{(\gamma_1^e+1)\tilde{\gamma}(s^{-1})}{1-\tilde{\gamma}(s^{-1})\gamma_2^x\gamma_1^e}$. Obviously $\bar{\alpha} \in \mathcal{K}$. Recall from the start of the proof that $\tilde{\gamma}$ in (14) is strictly decreasing on $\boldsymbol{\lambda}$ and $\lim_{\boldsymbol{\lambda} \rightarrow \infty} \tilde{\gamma}(\boldsymbol{\lambda}) = 0$. Then, $\varphi_1(0) = \varphi_2(0) = 0$, and thus $\varphi_1, \varphi_2 \in \mathcal{K}$. We conclude from (26) that the (χ, e) -subsystem is BIBS.

Step 2 (Convergence property): For any $0 \leq t_{10} \leq t_{20} \leq t_{11} \leq t_{21}$, we can use Assumption 3 and Proposition 2 to write

$$\mathbb{E}\{|\chi(t_{11})|\} \leq \beta_1(|\chi(t_{10})|, t_{11} - t_{10}) + \mu(\|(v, w)\|_{\mathcal{L}_\infty}) + \gamma_1^e \mathbb{E}\{\|e\|_{\mathcal{L}_\infty[t_{10}, t_{11}]}\} \quad (27a)$$

$$\mathbb{E}\{|e(t_{21})|\} \leq \beta_2(|e(t_{20})|, t_{21} - t_{20}) + \tilde{\gamma}(\boldsymbol{\lambda})\left(\gamma_2^x \mathbb{E}\{\|\chi\|_{\mathcal{L}_\infty[t_{20}, t_{21}]}\} + \sigma(\|(u, v, w, d)\|_{\mathcal{L}_\infty})\right). \quad (27b)$$

Let $t \in [0, \infty)$ and take $t_{10} = t/4$, $t_{20} = t/2$, $t_{21} = t$, and $t_{11} \in [t/2, t]$. In view of (27), and the bounds (24) and (25), we have

$$\begin{aligned} \mathbb{E}\{|e(t)|\} &\leq \beta_2(M_e, t/2) + \tilde{\gamma}(\boldsymbol{\lambda})\left(\gamma_2^x \left(\beta_1(M_\chi, t/4) + \gamma_1^e \mathbb{E}\{\|e\|_{\mathcal{L}_\infty[t/4, \infty)}\}\right) \right. \\ &\quad \left. + \mu(\|(v, w)\|_{\mathcal{L}_\infty})\right) + \sigma(\|(u, v, w, d)\|_{\mathcal{L}_\infty}). \end{aligned} \quad (28)$$

In the following, we will use Lemma 7 below, which is a special case of Lemma A.1 in [10].

Lemma 7 *Let $\beta \in \mathcal{KL}$, $\mu \in (0, 1]$, and $K \in [0, 1)$. For any $\lambda \in (1, \infty)$, $\exists \hat{\beta} \in \mathcal{KL}$ such that, for any $s, d \in \mathbb{R}_{\geq 0}$, and any nonnegative real function $\mathbf{z}(t) \in \mathcal{L}_\infty^e$ that satisfies $\mathbb{E}\{\mathbf{z}(t)\} \leq \beta(s, t) + K\mathbb{E}\{\|\mathbf{z}(t)\|_{\mathcal{L}_\infty[\mu t, \infty)}\} + d$, $\forall t \in [0, \infty)$, then $\mathbb{E}\{\mathbf{z}(t)\} \leq \hat{\beta}(s, t) + (1 - K)^{-1}\lambda d$, $\forall t \in [0, \infty)$. \square*

Consequently, using Lemma 7 in (28) with $\mathbf{z}(t) = |e(t)|$, $\beta(s, t) = \beta_2(s, t/2) + \tilde{\gamma}(\boldsymbol{\lambda}^*)\gamma_2^x\beta_1(s, t/4)$, $K = \tilde{\gamma}(\boldsymbol{\lambda})\gamma_2^x\gamma_1^e$ (which is < 1 given the choice of $\boldsymbol{\lambda}$), $d = \tilde{\gamma}(\boldsymbol{\lambda})\gamma_2^x\mu(\|(v, w)\|_{\mathcal{L}_\infty}) +$

$\tilde{\gamma}(\boldsymbol{\lambda})\sigma(\|(u, v, w, d)\|_{\mathcal{L}_\infty})$, and $\mu = 1/4$, implies $\exists \hat{\beta}_2 \in \mathcal{KL}$ such that for any $\lambda_2 \in (1, \infty)$,

$$\mathbb{E}\{|e(t)|\} \leq \hat{\beta}_2(M_e + M_\chi, t) + \frac{\lambda_2 \tilde{\gamma}(\boldsymbol{\lambda})}{1 - \tilde{\gamma}(\boldsymbol{\lambda})\gamma_2^x \gamma_1^e} \left(\gamma_2^x \mu(\|(v, w)\|_{\mathcal{L}_\infty}) + \sigma(\|(u, v, w, d)\|_{\mathcal{L}_\infty}) \right), \quad (29)$$

for all $t \geq 0$. Similarly, in view of (27), it can be shown that there exists $\hat{\beta}_1 \in \mathcal{KL}$ such that for any $\lambda_1 \in (1, \infty)$,

$$\mathbb{E}\{|\chi(t)|\} \leq \hat{\beta}_1(M_e + M_\chi, t) + \frac{\lambda_1}{1 - \tilde{\gamma}(\boldsymbol{\lambda})\gamma_2^x \gamma_1^e} \left(\mu(\|(v, w)\|_{\mathcal{L}_\infty}) + \tilde{\gamma}(\boldsymbol{\lambda})\gamma_1^e \sigma(\|(u, v, w, d)\|_{\mathcal{L}_\infty}) \right), \quad (30)$$

for all $t \geq 0$. Combining (29) and (30) leads to

$$\mathbb{E}\{|\chi(t), e(t)|\} \leq \hat{\beta}(M_e + M_\chi, t) + \lambda_1 \mu(\|(v, w)\|_{\mathcal{L}_\infty}) + \frac{\tilde{\gamma}(\boldsymbol{\lambda})}{1 - \tilde{\gamma}(\boldsymbol{\lambda})\gamma_2^x \gamma_1^e} \left((\lambda_2 \gamma_2^x + \lambda_1 \gamma_2^x \gamma_1^e) \mu(\|(v, w)\|_{\mathcal{L}_\infty}) + (\lambda_2 + \lambda_1 \gamma_1^e) \sigma(\|(u, v, w, d)\|_{\mathcal{L}_\infty}) \right),$$

for all $t \geq 0$, where $\hat{\beta}(s, t) = \hat{\beta}_1(s, t) + \hat{\beta}_2(s, t)$. From this point forward, we can proceed exactly as in the proof of Theorem 1 in [40] to show that (15) holds with $\beta(s, t) := \hat{\beta}(2\bar{\alpha}(s), t)$, $\eta_1(s) := \lambda_1 \mu(s) + \hat{\beta}(4\mu(s), 0)$, and $\eta_2(s_1, s_2) := \frac{\tilde{\gamma}(s_1^{-1})}{1 - \tilde{\gamma}(s_1^{-1})\gamma_2^x \gamma_1^e} \left((\lambda_2 \gamma_2^x + \lambda_1 \gamma_2^x \gamma_1^e) \mu(s_2) + (\lambda_2 + \lambda_1 \gamma_1^e) \sigma(s_2) \right) + \hat{\beta}(4\varphi_1(s_1) \mu(s_2) + 4\varphi_2(s_1) \sigma(s_2), 0)$. Note that $\beta(s, t) \in \mathcal{KL}$, $\eta_1(s) \in \mathcal{K}$, and $\eta_2(s_1, \cdot) \in \mathcal{K}$. Moreover, recall that $\tilde{\gamma}(\boldsymbol{\lambda})$ is a strictly decreasing function on $\boldsymbol{\lambda}$, thus so is $\tilde{\gamma}(\boldsymbol{\lambda})/(1 - \tilde{\gamma}(\boldsymbol{\lambda})\gamma_2^x \gamma_1^e)$, and thus $\eta_2(1/\boldsymbol{\lambda}^*, s_2) \in \mathcal{K}$ for $\boldsymbol{\lambda} \in (0, \infty)$, concluding the proof of (i) in Theorem 3.

(ii) In view of (15) and Assumption 1, for all $t \geq 0$,

$$\mathbb{E}\{|\chi(t), e(t), z(t)|\} \leq \beta(|(\chi_0, e_0)|, 0) + \eta_1(\|(v, w)\|_{\mathcal{L}_\infty}) + \eta_2(1/\boldsymbol{\lambda}^*, \|(u, v, w, d)\|_{\mathcal{L}_\infty}) + \nu_1(t) + \nu_2(|z_0|) + \nu_3(\mathbb{E}\{\|(x, e, u, v)\|_{\mathcal{L}_\infty}\}) + c.$$

Moreover, from (24) and (25) we know that $\mathbb{E}\{\|(x, e)\|_{\mathcal{L}_\infty}\} \leq M_\chi + M_e$. Then,

$$\begin{aligned} \nu_3(\mathbb{E}\{\|(x, e, u, v)\|_{\mathcal{L}_\infty}\}) &\leq \nu_3(2M_\chi + 2M_e) + \nu_3(2\|(u, v)\|_{\mathcal{L}_\infty}) \\ &\leq \nu_3(4\bar{\alpha}(|(\chi_0, e_0)|)) + \nu_3(2\|(u, v)\|_{\mathcal{L}_\infty}) + \nu_3(4\mu(\|(v, w)\|_{\mathcal{L}_\infty})) \\ &\quad + 4\varphi_1(1/\boldsymbol{\lambda}^*) \mu(\|(v, w)\|_{\mathcal{L}_\infty}) + 4\varphi_2(1/\boldsymbol{\lambda}^*) \sigma(\|(u, v, w, d)\|_{\mathcal{L}_\infty}). \end{aligned}$$

We can conclude from the above computations that (9) is forward complete in expectation with input $(u, v, w, d) \in \mathcal{L}_\infty$. \blacksquare

6.3 Proof of Proposition 4

(i) Let $\chi \in \mathbb{R}^{n_x}$, $z \in \mathbb{R}^{n_z}$, $e \in \mathbb{R}^n$, $u \in \mathbb{R}^{n_u}$, $v \in \mathbb{R}^{n_v}$, $w \in \mathbb{R}^{n_w}$, $d \in \mathbb{R}^{n_u+n_v}$. By the definition of g_e in (18), we have that,

$$\bar{g}_e(\chi, z, e, u, v, w, d) \preceq \begin{bmatrix} Cf_\chi(\chi, z, e, u, v, w) + d_v \\ \bar{d}_u \end{bmatrix} \preceq \begin{bmatrix} Cf_\chi(\chi, z, \varsigma, u, v, w) \\ 0 \end{bmatrix} + \begin{bmatrix} \bar{d}_v \\ \bar{d}_u \end{bmatrix}. \quad (31)$$

On the other hand, we have that $Cf_\chi = C(A_p + LC)\chi + C(\phi(u) - \phi(u + e^u)) + CL(e^y - e^{yz} + v) + Cw + C(G\psi(H(\chi + z)) - G\psi(Hz - KC\chi - Kv - K(e^y - e^{yz})))$. Then,

$$\begin{aligned} \overline{Cf_\chi} &\preceq \overline{C(A_p + LC)\chi} + \overline{C(\phi(u) - \phi(u + e^u))} + \overline{CL(e^y - e^{yz})} + \overline{CLv} \\ &\quad + \overline{Cw} + \overline{CG} \left(\overline{\psi(H(\chi + z)) - \psi(Hz - KC\chi - Kv - K(e^y - e^{yz}))} \right). \end{aligned} \quad (32)$$

The terms of the form $\overline{f(x) - f(x+y)}$ in (32), for globally Lipschitz f , can be bounded as follows.

$$\overline{\phi(u) - \phi(u + e^u)} = \begin{bmatrix} |\phi_1(u) - \phi_1(u + e^u)| \\ \vdots \\ |\phi_{n_x}(u) - \phi_{n_x}(u + e^u)| \end{bmatrix} \preceq \begin{bmatrix} \Phi |e^u| \\ \vdots \\ \Phi |e^u| \end{bmatrix} \preceq \Phi \mathbf{1}_{n_x \times n_u} \overline{(e^u)}$$

Similarly, we have that

$$\begin{aligned} & \overline{\psi(H(\chi + z)) - \psi(Hz - KC\chi - Kv - K(e^y - e^{yz}))} \\ & \preceq \Psi \begin{bmatrix} |(H + KC)\chi + Kv| + |K||e^y - e^{yz}| \\ \vdots \\ |(H + KC)\chi + Kv| + |K||e^y - e^{yz}| \end{bmatrix} \\ & = \Psi|(H + KC)\chi + Kv| \mathbf{1}_r + \Psi|K| \mathbf{1}_{r \times n_y} \overline{(e^y - e^{yz})}. \end{aligned}$$

With the above, (32) becomes

$$\begin{aligned} \overline{Cf_\chi} \preceq & \overline{C(A_p + LC)\chi} + \Psi \overline{CG} |(H + KC)\chi + Kv| \mathbf{1}_r + \overline{CLv} + \overline{Cw} \\ & + (\overline{CL} + \Psi|K| \overline{CG} \mathbf{1}_{r \times n_y}) \overline{(e^y - e^{yz})} + \Phi \overline{C} \mathbf{1}_{n_x \times n_u} \overline{(e^u)}. \end{aligned} \quad (33)$$

The proof is thus complete in view of (31) and (33).

- (ii) Taking the euclidean norm of \tilde{y} in (20), and using the triangle inequality, we have that $|\tilde{y}| \leq |C(A_p + LC)| |\chi| + \Psi |CG| |H + KC| |\chi| \mathbf{1}_r + \Psi |CG| |K| |v| \mathbf{1}_r + |CL| |v| + |C| |w| + |d_v| + |d_u|$, which completes the proof.
- (iii) Under Assumption 4, and using the property $\lambda_{\min}(P) |\chi|^2 \leq V(\chi) \leq \lambda_{\max}(P) |\chi|^2$, and the fact that $2ab \leq (c/5)a^2 + (5/c)b^2$, we have that along solutions to $\dot{\chi} = f_\chi(\chi, z, e, v, w)$, for all $t \geq 0$,

$$\begin{aligned} \dot{V} & \leq -cV + 2|\chi| \left(\Psi |PG| |K| (e^y - e^{yz}) + Kv| + |PL| (e^y - e^{yz}) + PLv| + |P| |w| + \Phi |P| |e^u| \right), \\ & \leq -cV + \frac{2\sqrt{V}}{\sqrt{\lambda_{\min}(P)}} \left((\Psi |PG| |K| + |PL|) |e^y - e^{yz}| + \Phi |P| |e^u| + (|K| + |PL|) |v| + |P| |w| \right) \\ & \leq -\frac{c}{5}V + \frac{5(\Psi |PG| |K| + |PL|)^2}{c\lambda_{\min}(P)} |e^y - e^{yz}|^2 + \frac{5\Phi^2 |P|^2}{c\lambda_{\min}(P)} |e^u|^2 + \frac{5(|K| + |PL|)^2}{c\lambda_{\min}(P)} |v|^2 \\ & \quad + \frac{5|P|^2}{c\lambda_{\min}(P)} |w|^2 \\ & \leq -\frac{c}{5}V + \max \left\{ \frac{5(\Psi |PG| |K| + |PL|)^2}{c\lambda_{\min}(P)}, \frac{5\Phi^2 |P|^2}{c\lambda_{\min}(P)} \right\} |e|^2 + \frac{5(|K| + |PL|)^2}{c\lambda_{\min}(P)} |v|^2 \\ & \quad + \frac{5|P|^2}{c\lambda_{\min}(P)} |w|^2, \end{aligned} \quad (34)$$

where \dot{V} denotes $dV(\chi(t))/dt$.

Define $C_e \doteq \max \left\{ \frac{5(\Psi |PG| |K| + |PL|)^2}{c\lambda_{\min}(P)}, \frac{5\Phi^2 |P|^2}{c\lambda_{\min}(P)} \right\}$, $C_v \doteq \frac{5(|K| + |PL|)^2}{c\lambda_{\min}(P)}$ and $C_w \doteq \frac{5|P|^2}{c\lambda_{\min}(P)}$.

We invoke the comparison principle for (34) (see Lemma 3.4 in [64]) and get

$$V(\chi(t)) \leq \exp\left(-\frac{c}{5}(t - t_0)\right) V(\chi(t_0)) + \frac{5}{c} \left(C_e \|e\|_{\mathcal{L}_\infty[t_0, t]}^2 + C_v \|v\|_{\mathcal{L}_\infty[t_0, t]}^2 + C_w \|w\|_{\mathcal{L}_\infty[t_0, t]}^2 \right).$$

Therefore, $|\chi(t)| \leq \sqrt{\frac{\lambda_{\max}(P)}{\lambda_{\min}(P)}} \exp\left(-\frac{c}{10}(t - t_0)\right) |\chi(t_0)| + \sqrt{\frac{5C_e}{c\lambda_{\min}(P)}} \|e\|_{\mathcal{L}_\infty[t_0, t]} + \sqrt{\frac{5C_v}{c\lambda_{\min}(P)}} \|v\|_{\mathcal{L}_\infty[t_0, t]} + \sqrt{\frac{5C_w}{c\lambda_{\min}(P)}} \|w\|_{\mathcal{L}_\infty[t_0, t]}$, which completes the proof via linearity of the expectation operator $\mathbb{E}\{\cdot\}$. \blacksquare

7 Conclusions

We proposed an emulation-based framework for state estimation of general non-linear plants subject to external disturbances and measurement noise, and that communicate with the observer over a wireless network. The network adopts a stochastic protocol for the nodes, and each node is subject to both random packet losses and random transmission instants. We provided sufficient conditions on the rate of transmission that ensure convergence of the mean of the estimation error under the network-induced constraints. Future work will focus on considering different packet loss models and protocols.

Declarations

- **Funding:** This work was supported by the Australian Research Council under the Discovery Grant DP200101303.
- **Conflict of interest:** The authors have no competing interests to declare that are relevant to the content of this article.

References

- [1] Sontag, E.D.: Smooth stabilization implies coprime factorization. *IEEE Transactions on Automatic Control* **34**(4), 435–443 (1989)
- [2] Dashkovskiy, S., Efimov, D.V., Sontag, E.D.: Input to state stability and allied system properties. *Automation and Remote Control* **72**(8), 1579–1614 (2011)
- [3] Isidori, A.: *Nonlinear Control Systems*, 3rd edn. Communications and control engineering. Springer, New York (1995)
- [4] Kokotović, P., Arcak, M.: Constructive nonlinear control: a historical perspective. *Automatica* **37**(5), 637–662 (2001)
- [5] Angeli, D., Sontag, E.D., Wang, Y.: A characterization of integral input-to-state stability. *IEEE Transactions on Automatic Control* **45**(6), 1082–1097 (2000)
- [6] Angeli, D., Sontag, E.D., Wang, Y.: Input-to-state stability with respect to inputs and their derivatives. *International Journal of Robust and Nonlinear Control: IFAC-Affiliated Journal* **13**(11), 1035–1056 (2003)
- [7] Sontag, E.D., Wang, Y.: Notions of input to output stability. *Systems & Control Letters* **38**(4-5), 235–248 (1999)
- [8] Angeli, D., Sontag, E.D.: Forward completeness, unboundedness observability, and their Lyapunov characterizations. *Systems & Control Letters* **38**(4-5), 209–217 (1999)
- [9] Christofides, P.D., Teel, A.R.: Singular perturbations and input-to-state stability. *IEEE Transactions on Automatic Control* **41**(11), 1645–1650 (1996)
- [10] Jiang, Z.-P., Teel, A.R., Praly, L.: Small-gain theorem for ISS systems and applications. *Mathematics of Control, Signals and Systems* **7**(2), 95–120 (1994)
- [11] Marino, R., Tomei, P.: Nonlinear output feedback tracking with almost disturbance decoupling. *IEEE Transactions on Automatic Control* **44**(1), 18–28 (1999)
- [12] Hu, X.: On state observers for nonlinear systems. *Systems & Control Letters* **17**(6), 465–473 (1991)
- [13] Shim, H., Liberzon, D.: Nonlinear observers robust to measurement disturbances in an ISS sense. *IEEE Transactions on Automatic Control* **61**(1), 48–61 (2015)

- [14] Nešić, D., Teel, A.: Input-output stability properties of networked control systems. *IEEE Transactions on Automatic Control* **49**(10), 1650–1667 (2004)
- [15] Nešić, D., Teel, A.R.: Input-to-state stability of networked control systems. *Automatica* **40**(12), 2121–2128 (2004)
- [16] Postoyan, R., Nešić, D.: A framework for the observer design for networked control systems. *IEEE Transactions on Automatic Control* **57**(5), 1309–1314 (2012)
- [17] Park, P., Ergen, S.C., Fischione, C., Lu, C., Johansson, K.H.: Wireless network design for control systems: A survey. *IEEE Communications Surveys & Tutorials* **20**(2), 978–1013 (2017)
- [18] Ahlén, A., Akerberg, J., Eriksson, M., Isaksson, A.J., Iwaki, T., Johansson, K.H., Knorn, S., Lindh, T., Sandberg, H.: Toward wireless control in industrial process automation: A case study at a paper mill. *IEEE Control Systems Magazine* **39**(5), 36–57 (2019)
- [19] Ugrinovskii, V., Fridman, E.: A round-robin type protocol for distributed estimation with H_∞ consensus. *Systems & Control Letters* **69**, 103–110 (2014)
- [20] Walsh, G., Ye, H., Bushnell, L.: Stability analysis of networked control systems. *IEEE Transactions on Control Systems Technology* **10**(3), 438–446 (2002)
- [21] Tabbara, M., Nešić, D.: Input–output stability of networked control systems with stochastic protocols and channels. *IEEE Transactions on Automatic control* **53**(5), 1160–1175 (2008)
- [22] Chen, D., Nixon, M., Mok, A.: Why WirelessHART. In: *WirelessHART™*, pp. 195–199. Springer, Boston, MA (2010)
- [23] Maass, A.I., Nešić, D.: Stabilization of non-linear networked control systems closed over a lossy WirelessHART network. *IEEE Control Systems Letters* **3**(4), 996–1001 (2019)
- [24] Donkers, M.C.F., Heemels, W.P.M.H., Bernardini, D., Bemporad, A., Shneer, V.: Stability analysis of stochastic networked control systems. *Automatica* **48**(5), 917–925 (2012)
- [25] Liu, K., Fridman, E., Johansson, K.H.: Networked control with stochastic scheduling. *IEEE Transactions on Automatic Control* **60**(11), 3071–3076 (2015)
- [26] Zou, L., Wang, Z., Gao, H.: Observer-based \mathcal{H}_∞ control of networked systems with stochastic communication protocol: The finite-horizon case. *Automatica* **63**, 366–373 (2016)
- [27] Zou, L., Wang, Z., Gao, H., Alsaadi, F.E.: Finite-horizon \mathcal{H}_∞ consensus control of time-varying multiagent systems with stochastic communication protocol. *IEEE Transactions on Cybernetics* **47**(8), 1830–1840 (2017)
- [28] Zhang, J., Fridman, E.: Dynamic event-triggered control of networked stochastic systems with scheduling protocols. *IEEE Transactions on Automatic Control* (2021)
- [29] Yuan, Y., Wang, Z., Zhang, P., Liu, H.: Near-optimal resilient control strategy design for state-saturated networked systems under stochastic communication protocol. *IEEE Transactions on Cybernetics* **49**(8), 3155–3167 (2018)
- [30] Liu, S., Wang, Z., Wang, L., Wei, G.: On quantized \mathcal{H}_∞ filtering for multi-rate systems under stochastic communication protocols: The finite-horizon case. *Information Sciences* **459**, 211–223 (2018)
- [31] Zou, L., Wang, Z., Han, Q.-L., Zhou, D.: Recursive filtering for time-varying systems with random access protocol. *IEEE Transactions on Automatic Control* **64**(2), 720–727 (2018)

- [32] Zhao, Y., He, X., Ma, L., Liu, H.: Estimator-based iterative deviation-free residual generator for fault detection under random access protocol. *Neurocomputing* (2022)
- [33] Zou, L., Wang, Z., Hu, J., Gao, H.: On \mathcal{H}_∞ finite-horizon filtering under stochastic protocol: Dealing with high-rate communication networks. *IEEE Transactions on Automatic Control* **62**(9), 4884–4890 (2017)
- [34] Alsaadi, F.E., Luo, Y., Liu, Y., Wang, Z.: State estimation for delayed neural networks with stochastic communication protocol: The finite-time case. *Neurocomputing* **281**, 86–95 (2018)
- [35] Chen, S., Guo, J., Ma, L.: Sliding mode observer design for discrete nonlinear time-delay systems with stochastic communication protocol. *International Journal of Control, Automation and Systems* **17**(7), 1666–1676 (2019)
- [36] Zou, L., Wang, Z., Han, Q.-L., Zhou, D.: Moving horizon estimation of networked nonlinear systems with random access protocol. *IEEE Transactions on Systems, Man, and Cybernetics: Systems* (2019)
- [37] Ju, Y., Liu, D., Ding, D., Wei, G.: Distributed cubature kalman filtering for nonlinear systems with stochastic communication protocol. *Asian Journal of Control* (2022)
- [38] Walsh, G.C., Beldiman, O., Bushnell, L.G.: Asymptotic behavior of nonlinear networked control systems. *IEEE Transactions on Automatic Control* **46**(7), 1093–1097 (2001)
- [39] Maass, A.I., Nešić, D., Postoyan, R., Varma, V.S., Lasaulce, S.: Wireless networked control systems: Stochastic stability and power control. Submitted to *Automatica* (2022)
- [40] Maass, A.I., Nešić, D., Postoyan, R., Dower, P.M.: Observer design for non-linear networked control systems with persistently exciting protocols. *IEEE Transactions on Automatic Control* **65**(7), 2992–3006 (2019)
- [41] Maass, A.I., Nešić, D.: State estimation of non-linear systems over random access wireless networks. In: *Proceedings of the 60th IEEE Conference on Decision and Control, Austin, Texas, USA* (2021)
- [42] Tabbara, M., Nešić, D., Teel, A.R.: Stability of wireless and wireline networked control systems. *IEEE Transactions on Automatic Control* **52**(9), 1615–1630 (2007)
- [43] Hespanha, J.P., Teel, A.R.: Stochastic impulsive systems driven by renewal processes. In: *17th International Symposium on Mathematical Theory of Networks and Systems (MTNS06)* (2006)
- [44] Hu, Z., Yang, Z., Mu, X.: Stochastic input-to-state stability of random impulsive nonlinear systems. *Journal of the Franklin Institute* **356**(5), 3030–3044 (2019)
- [45] Agarwal, R., Hristova, S., O’Regan, D.: Exponential stability for differential equations with random impulses at random times. *Advances in Difference Equations* **2013**(1), 1–12 (2013)
- [46] Tijms, H.C.: *A First Course in Stochastic Models*. John Wiley and sons, Chichester (2003)
- [47] Garone, E., Sinopoli, B., Goldsmith, A., Casavola, A.: LQG control for MIMO systems over multiple erasure channels with perfect acknowledgment. *IEEE Transactions on Automatic Control* **57**(2), 450–456 (2012)
- [48] Haßlinger, G., Hohlfeld, O.: The Gilbert-Elliott model for packet loss in real time services on the internet. In: *14th GI/ITG Conference-Measurement, Modelling and Evaluation of Computer and Communication Systems*, pp. 1–15 (2008). VDE
- [49] Postoyan, R., Van de Wouw, N., Nešić, D., Heemels, W.P.M.H.: Tracking control for

- nonlinear networked control systems. *IEEE Transactions on Automatic Control* **59**(6), 1539–1554 (2014)
- [50] Ahmed-Ali, T., Lamnabhi-Lagarrigue, F.: High gain observer design for some networked control systems. *IEEE Transactions on Automatic Control* **57**(4), 995–1000 (2012)
- [51] Chandra, A.K., Raghavan, P., Ruzzo, W.L., Smolensky, R., Tiwari, P.: The electrical resistance of a graph captures its commute and cover times. *Computational Complexity* **6**(4), 312–340 (1996)
- [52] Upfal, E., Mitzenmacher, M.: *Probability and Computing: Randomized Algorithms and Probabilistic Analysis*. Cambridge University Press, Cambridge (2005)
- [53] Stirzaker, D.: *Stochastic Processes and Models*. Oxford University Press, Oxford (2005)
- [54] Nasipuri, A., Zhuang, J., Das, S.R.: A multichannel CSMA MAC protocol for multihop wireless networks. In: *IEEE Wireless Communications and Networking Conference (Cat. No. 99TH8466)*, vol. 3, pp. 1402–1406 (1999). IEEE
- [55] Teel, A.R., Subbaraman, A., Sferlazza, A.: Stability analysis for stochastic hybrid systems: A survey. *Automatica* **50**(10), 2435–2456 (2014)
- [56] Hespanha, J.P.: A model for stochastic hybrid systems with application to communication networks. *Nonlinear Analysis: Theory, Methods & Applications* **62**(8), 1353–1383 (2005)
- [57] Astolfi, D., Alessandri, A., Zaccarian, L.: Stubborn and dead-zone redesign for nonlinear observers and filters. *IEEE Transactions on Automatic Control* **66**(2), 667–682 (2020)
- [58] Bernard, P., Andrieu, V., Astolfi, D.: Observer design for continuous-time dynamical systems. *Annual Reviews in Control* (2022)
- [59] Jiao, T., Zheng, W.X., Xu, S.: Stability analysis for a class of random nonlinear impulsive systems. *International Journal of Robust and Nonlinear Control* **27**(7), 1171–1193 (2017)
- [60] Rajamani, R.: Observers for Lipschitz nonlinear systems. *IEEE transactions on Automatic Control* **43**(3), 397–401 (1998)
- [61] Arcak, M., Kokotovic, P.: Observer-based control of systems with slope-restricted nonlinearities. *IEEE Transactions on Automatic Control* **46**(7), 1146–1150 (2001)
- [62] Khalil, H.K.: *Nonlinear Control*. Pearson Education, New York (2015)
- [63] Arcak, M.: *Unmodeled dynamics in robust nonlinear control*. PhD thesis, University of California, Santa Barbara, United States (2000)
- [64] Khalil, H.K.: *Nonlinear Systems*, 3rd edn. Prentice Hall, New Jersey (2002)
- [65] Williams, D.: *Probability with Martingales*. Cambridge University Press, Cambridge (1991)
- [66] Jiang, Z.-P., Teel, A.R., Praly, L.: Small-gain theorem for ISS systems and applications. *Mathematics of Control, Signals and Systems* **7**(2), 95–120 (1994)