



HAL
open science

Magnetoencephalography and Language

Suzanne Dikker, M. Florencia Assaneo, Laura Gwilliams, Lin Wang, Anne Kösem

► **To cite this version:**

Suzanne Dikker, M. Florencia Assaneo, Laura Gwilliams, Lin Wang, Anne Kösem. Magnetoencephalography and Language. *Neuroimaging Clinics of North America*, 2020, 30 (2), pp.229-238. 10.1016/j.nic.2020.01.004 . hal-03921443

HAL Id: hal-03921443

<https://hal.science/hal-03921443>

Submitted on 29 Jan 2024

HAL is a multi-disciplinary open access archive for the deposit and dissemination of scientific research documents, whether they are published or not. The documents may come from teaching and research institutions in France or abroad, or from public or private research centers.

L'archive ouverte pluridisciplinaire **HAL**, est destinée au dépôt et à la diffusion de documents scientifiques de niveau recherche, publiés ou non, émanant des établissements d'enseignement et de recherche français ou étrangers, des laboratoires publics ou privés.

MEG and Language: Using Magnetoencephalography to Study the Neural Basis of Language

Suzanne Dikker^{1*}, Florencia Assaneo¹, Laura Gwilliams^{1,2}, Lin Wang³, Anne Kösem⁴

(1) Department of Psychology, New York University, 6 Washington Place #275, New York, NY 10003, USA;

(2) New York University Abu Dhabi Research Institute, New York University Abu Dhabi, Saadiyat Island, Abu Dhabi, United Arab Emirates

(3) Department of Psychiatry, Athinoula A. Martinos Center for Biomedical Imaging, Massachusetts General Hospital, Harvard Medical School, 149 Thirteenth Street, #2306, Charlestown, MA 02129, USA

(4) Lyon Neuroscience Research Center (CRNL), CH Le Vinatier Bâtiment 452, 95, BD Pinel, Bron, Lyon 69675, France

* Corresponding author

CORRESPONDING AUTHOR

Suzanne Dikker, NYU Dept. of Psychology; 6 Washington Place #275, New York NY 10003;
suzanne.dikker@nyu.edu

DISCLOSURE STATEMENT

All authors report that they have no conflict of interest.

KEYWORDS

MEG, language, speech, reading, neurolinguistics, synchronization, decoding, semantics

KEY POINTS

- Its high temporal resolution and relatively accurate spatial resolution make MEG an ideal tool to investigate the complex brain dynamics supporting language comprehension and production
- Event-related designs using single words or simple, well-controlled phrases have helped characterize the building blocks of language as well as the different linguistic processing stages, from identifying sounds to syntactic phrase building
- More recent methodological approaches, such as investigating neural oscillations and decoding techniques, allow researchers to study dynamic naturalistic language comprehension and production
- Linguistically relevant brain MEG responses are atypical in language disorders

SYNOPSIS

We provide an introductory overview of research that uses magnetoencephalography (MEG) to understand the brain basis of human language. The cognitive processes and brain networks that have been implicated in written and spoken language comprehension and production are discussed in relation to different methodologies: we briefly review event-related brain responses, research on the coupling of neural oscillations to speech, oscillatory coupling between brain regions (e.g., auditory-motor coupling), and neural decoding approaches in naturalistic language comprehension. We end with a short section on the clinical relevance of MEG language research, focusing on dyslexia and specific language impairment.

ACKNOWLEDGMENTS

This work is supported by NIH 2R01DC05660, NSF ECR-1661016, Marie Skłodowska-Curie Individual Fellowship MSCA-IF-2018-843088, and Abu Dhabi Institute Grant G1001.

Introduction

Language is among the most complex of human cognitive systems, yet its processing is extremely automated and fast: Both behavioral and neurophysiological studies suggest that within 600 milliseconds of a word's onset its sensory properties have been analyzed, its grammatical and semantic features have been retrieved from memory, and it has been integrated into the ongoing discourse. In this chapter, we provide a brief overview, summarized in Figure 1, of research that has capitalized on MEG's spatio-temporal resolution to capture the neural dynamics that support linguistic operations. First, we briefly review event-related designs using single words or simple, well-controlled phrases, which have helped characterize the building blocks of language and its processing stages, from identifying individual sounds or letters to sentence-level grammar. We then discuss more recent methodological approaches exploring neural oscillations and decoding techniques, which can be applied to more naturalistic language. These tools have allowed researchers to study how linguistically relevant brain responses are coupled between brain regions and across modalities, and to capture language-relevant brain responses that are highly distributed across space and vary in timing. We conclude with a brief section exemplifying the clinical relevance of the reviewed research.

Evoked responses to linguistic input

Early brain responses to written words

In a now classic study, Tarkiainen and colleagues¹ compared brain responses to symbols and letter strings and identified two early event-related MEG responses to visual word recognition¹. Later studies have built on this work to identify early language-related MEG components, or event-related fields (ERFs)^{2,3}. As listed in Figure 1, the so-called visual M100 response has been associated with low-level visual feature processing⁴, the M130 component shows sensitivity to orthographic features³ (e.g., how often two letters co-occur in written words), and the M170 response is sensitive to the morphological properties of words⁵. For example, bimorphemic words elicit a higher M170 amplitude than orthographically matched monomorphemic words (“farm-er” has two morphemes, or meaningful units, vs “corner”, which consists of one morpheme but also

ends in “-er”⁵). fMRI evidence from manipulations similar to those affecting the M170 suggests that the response is generated in left and right fusiform gyri ⁶.

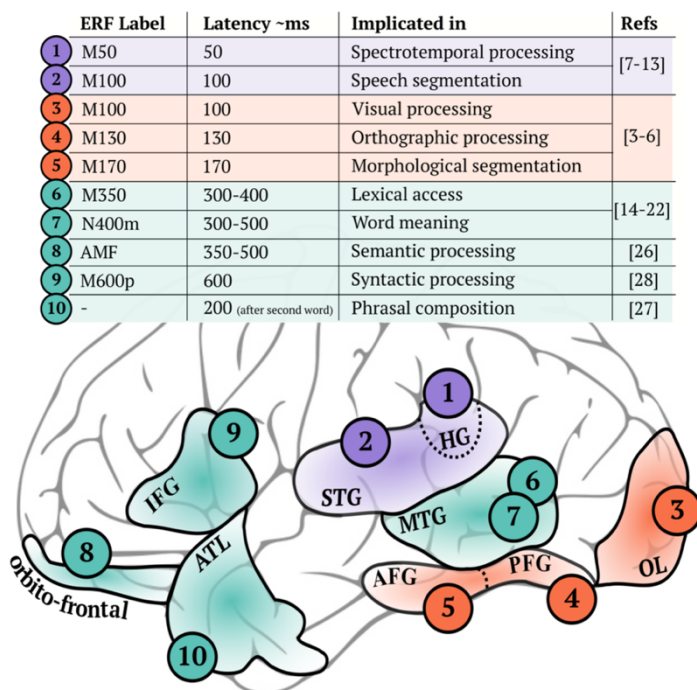

Figure 1. Putative brain regions and event-related responses associated with language processing. Orange: modality-specific written word processes. Purple: modality-specific spoken word processes. Turquoise: a-modal processes. OL: occipital lobe; PFG: posterior fusiform gyrus; AFG: anterior fusiform gyrus; HG: Heschl's gyrus; STG: superior temporal gyrus; MTG: middle temporal gyrus; ATL: anterior temporal lobe; IFG: inferior frontal gyrus. Figure adapted, with permission, from Gwilliams (in press). *How the brain composes morphemes into meaning. Philosophical Transactions of the Royal Society of B.*

Identifying phonetic and morphemic information in spoken language

Systematic early responses to *spoken* language can also be identified. Relative to the onset of each speech sound, evoked responses at 50 ms in primary auditory cortex are modulated by low-level spectro-temporal properties of the input, followed by a 100 ms response in superior temporal gyrus ⁷⁻¹⁰. This latter response has been associated with the mapping of variable acoustic information onto more stable phonetic features (e.g., the acoustics of [p] vary between speakers and contexts, like in [plant] vs. [park], but these different sounds are mapped onto a single meaningful phoneme in the perceiver's brain) ¹¹.

Having identified the phonemes, these are then mapped onto words (via morphemes, see above). This process has been explained through the prevalent *cohort model* of spoken word recognition (Figure 2): as a listener hears each phoneme of a word (i.e., the spoken equivalent of a letter), this information is used to narrow down the cohort of words that are consistent with the input. When just one word remains, this is the winner of the lexical competition, and thus the word that is recognized. Previous MEG studies have found evidence in favor of this mechanism by

tracking responses to each speech sound in the word, and correlating activity at around 200 ms after phoneme onset in superior temporal gyrus with the number of remaining morphological candidates ^{10,12,13} (Figure 2).

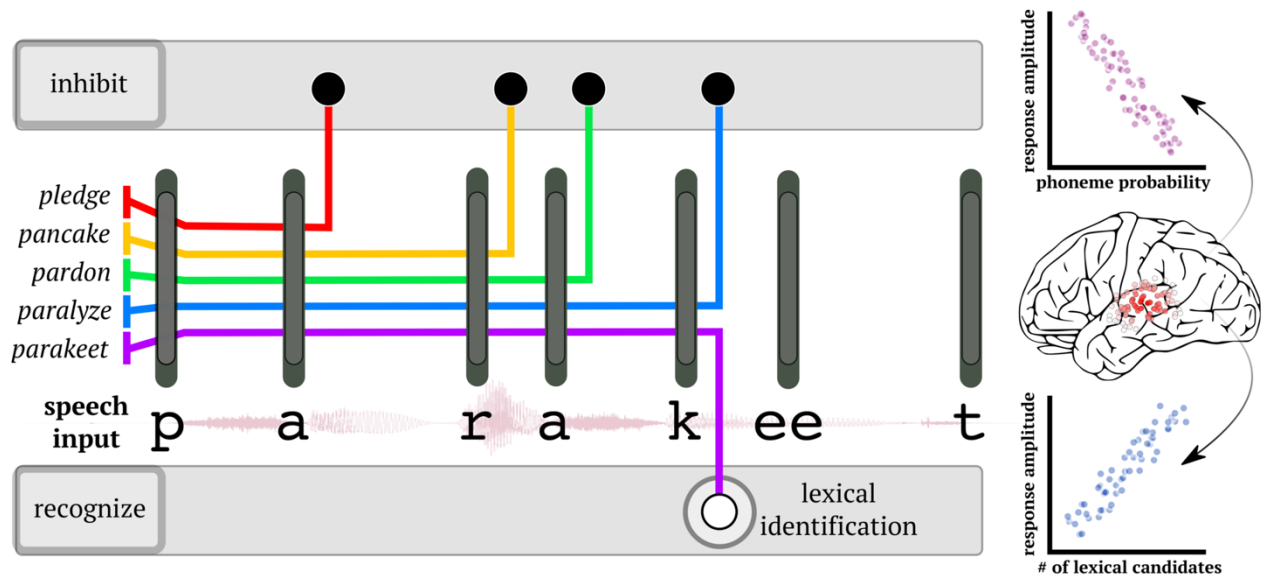
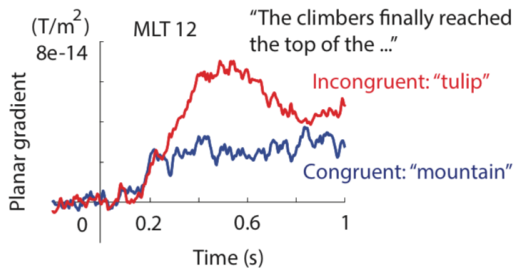

Figure 2. Schematic of spoken word recognition. As the word unfolds, with each phoneme (gray bars), possible lexical candidates for recognition are ruled out. This process continues until only one word remains consistent with the input (e.g. “parakeet”). Notice that the word can be uniquely identified before word offset -- at the “k” phoneme. Activity in left superior temporal gyrus has been shown to track the probability of each phoneme in a word (“phoneme surprisal”), as well as the relative probability of remaining lexical candidates (“cohort entropy”). Figure courtesy Laura Gwilliams.

Deriving the meaning of words in isolation and in context

Once the words have been identified, their meaning can be derived. A large body of MEG studies have compared evoked brain responses to words differing in lexical properties (words vs. non-words; abstract vs. concrete words ²), preceding word contexts (e.g., “dog” preceded by “cat” vs. “dog” preceded by “table” ^{14,15}), or sentence contexts (e.g., “mountain” vs. “tulip” in “The climbers finally reached the top of the ...” ¹⁶⁻¹⁸; Figure 3A). When semantic features of a word are easier to access, smaller evoked MEG responses are observed approximately 300-500 ms after word onset (corresponding to the N400 in EEG ¹⁹). This N400m effect has been consistently localized within the left lateral temporal cortex, including superior and middle temporal regions (Figure 3B).

(A) Sensor-level evoked response



(B) Source localization of the evoked response difference

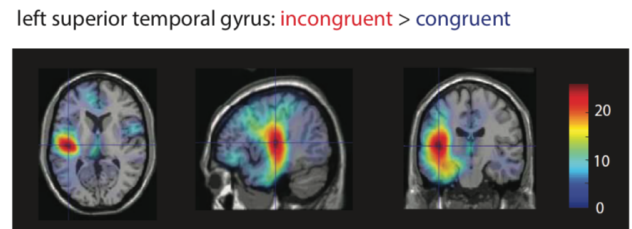

Figure 3. Evoked responses to congruent vs. incongruent words in sentence contexts. (A) The planar gradient of the ERFs time-locked to the onset of the critical words at a representative left temporal sensor. Approximately between 200ms and 700ms after the critical words, the incongruent words (e.g. “tulip”) elicited larger amplitudes than the congruent words (e.g. “mountain”). (B) Source localization of the N400m effect using MNE. Figure adapted, with permission, from Wang et al. (2012) Beta oscillations relate to the N400m during language comprehension. *Human Brain Mapping*, 33(12), 2898–2912.

This is in line with the well-established role of these regions in representing lexico-semantic information, as revealed by fMRI²⁰. Importantly, while early ERFs are modality specific, semantic activation appears to be modality-independent: overlapping brain regions are activated during the N400m time window for both written and spoken language²¹. In addition to the left temporal cortex, a number of MEG studies report increased activation within the left inferior frontal cortex for semantically incongruous words^{22,23}. This region has been suggested to play a role in selecting and controlling lexical retrieval under contextual influence^{16,24} and in unifying multiple sources of information²⁵.

Combining words: syntax and sentence-level semantics

While the bulk of studies focus on processing word meaning, some research also examines sentence-level combinatorics²⁶. For example, when comparing the word “boat” in either a word list or as part of the phrase “red boat”, the latter leads to linguistic composition-related activity in the left anterior temporal lobe and ventromedial prefrontal cortex (e.g.,²⁷, see Figure 1). And “going” vs. “go” in a sentence like “She will going/go to the bakery for a loaf of bread.”²⁸ elicit a stronger response after 600 ms, consistently source-localized to temporal regions, corresponding to the P600 effect observed in EEG research²⁹.

Syntactically incongruous words sometimes also elicit stronger early *sensory* responses than grammatical sentences, as early as 100 ms post-word onset^{4,30–32}. Recall that research investigating words in isolation yielded no evidence that the brain is sensitive to lexical or

grammatical properties in sensory cortices. This discrepancy between word-level and sentence-level findings has been explained in terms of a prediction-based account: words and grammar can be anticipated (and thus preactivated) based on the preceding context, allowing for a more efficient detection of linguistically relevant features. For example, the brain may generate estimates of the likely physical appearance of upcoming words based on grammar-based predictions, and words that do not ‘look’ or ‘sound’ like the expected grammatical category then show increased early sensory responses. Many of the studies cited above in relation to lexical-semantic processing have similarly accounted for N400m effects in terms of prediction ^{14,33,34}.

Beyond ERFs and toward naturalistic experimentation

In recent years, a shift has been made towards a more naturalistic experimental setup (e.g., ³⁵) where participants listen to continuous speech, such as stories, rather than being presented with isolated words or short sentences. As the evoked response to natural language at a certain time point may reflect a cascade of processes initiated at different (and overlapping) moments in time, researchers have resorted to other analysis techniques to study continuous speech.

The role of neural oscillations in language

Tracking continuous speech: brain-to-stimulus synchrony

There is strong evidence that brain oscillations synchronize to the temporal regularities of speech during listening ³⁶⁻³⁹: low-frequency neural oscillations in the theta and delta range (1-8 Hz) synchronize to the dynamics of the speech envelope associated with syllabic and phrasal rates presentation respectively, and high-frequency neural activity in the gamma range (30-40 Hz) follow the fine-grained temporal dynamics related to phonetic features ⁴⁰ (Figure 4A).

Neural oscillations have been experimentally linked to the *understanding* of speech (i.e., beyond mere speech acoustics): brain-to-speech synchronization is stronger when speech is intelligible (Figure 4B) ⁴¹⁻⁴³, and brain oscillations in the delta and gamma range synchronize to the lexical and grammatical structures of spoken sentences ⁴⁴⁻⁴⁶. In multi-talker settings, neural oscillations synchronize to the dynamics of the attended speaker (the so-called ‘cocktail party

effect'). Importantly, the strength of the synchronization indicates how successful the auditory scene analysis is performed⁴⁷⁻⁴⁹ (Figure 4C).

Neural oscillations are hypothesized to play a crucial role during speech parsing by defining the temporal boundaries between linguistic items within the continuous acoustic signal⁴⁰. Importantly, brain-to-speech synchrony is suggested to be a predictive mechanism, parsing and structuring events from continuous speech by building temporal expectations on the upcoming auditory input^{50,51}. In support of this view, neural oscillations entrain (synchronize) to the syllabic rate of speech in a sustained manner, and neural entrainment to ongoing speech is dependent on the rate of preceding speech. Importantly, brain-to-speech synchrony at specific rates directly affects how words are understood⁵² (Figure 4D).

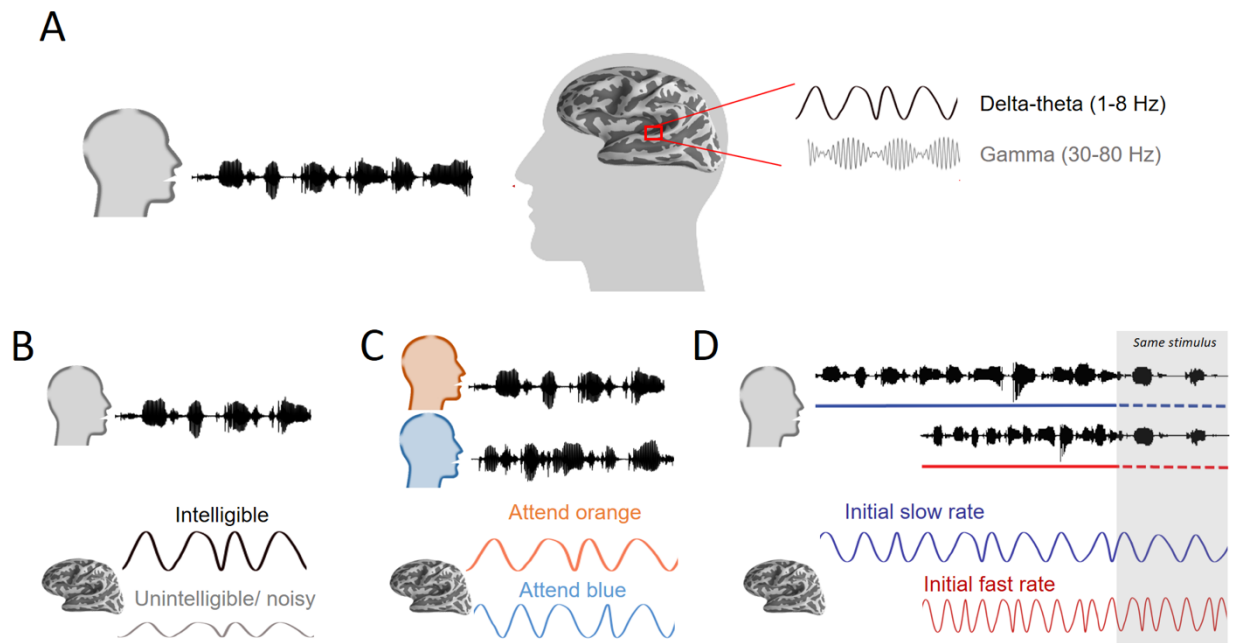

Figure 4. Brain-to stimulus synchrony and speech processing. (A) Brain signal synchronizes to the dynamics of speech. (B) Brain-to-stimulus synchrony is stronger when speech is intelligible⁴¹⁻⁴³. (C) Brain oscillations follow attended speech in multi-talker settings⁴⁷⁻⁴⁹. (D) Brain oscillations are influenced by contextual speech rhythm information⁵². Figure courtesy Anne Kösem.

The role of neural oscillations in deriving meaning

Examining oscillatory activity has also allowed researchers to closely track the cortical dynamics underlying semantic processing in event-related designs, substantially enriching the information obtained by studying ERFs. For example, during sentence comprehension, desynchronization of neural oscillations in the alpha (8-12 Hz) and beta (12-20 Hz) range within the left temporal and

frontal regions are observed when processing semantically incongruent (versus congruent) words in sentence contexts^{18,28,53} or for words appearing in sentences vs. word lists⁵⁴. The desynchronized alpha/beta activity might reflect the engagement of task-relevant brain regions to support sentence-level processing. Furthermore, connectivity analyses in MEG studies have revealed functional connectivity patterns between the left inferior frontal and temporal cortex during sentence comprehension. Granger causality analysis suggests that alpha activity supports information transfer from temporal to frontal regions, whereas beta activity supports information transfer from frontal to temporal regions⁵⁵. The connectivity between the left frontal and temporal regions was also found by synchronized beta and low-gamma oscillations for processing unexpected compared to expected sentence-final words⁵⁶. Moreover, cross-frequency connectivity between gamma power within the left prefrontal region and alpha power within the left temporal region was reported for processing expected but not unexpected sentence-final words, both before and after the words were presented⁵³. These findings suggest that the communication between the left inferior frontal and temporal cortex is supported by different patterns of oscillatory activity. Further studies are needed to systematically examine how the communication between different brain regions (e.g., feedforward vs. feedback control) is realized via different patterns of synchronization (e.g., phase-locking, amplitude synchronization, phase-amplitude coupling) in different frequency bands^{53,57}.

Auditory-motor interaction in speech

In the middle of the past century, researchers observed that phonemes cannot be unequivocally defined in the acoustic space, and proposed that phoneme perception instead occurs in motor space: incoming speech sounds are mapped to invariant neuromotor commands^{58,59}. This hypothesis, dubbed the *motor theory of speech* perception, has been strongly criticized^{60–65}, but less stringent versions are supported by findings that passive listening to speech activates areas involved in speech production^{66,67}. MEG data show that oscillations generated in left inferior frontal and precentral gyri (areas typically involved in speech production) modulate the phase of low-frequency activity in left auditory regions significantly stronger when speech is intelligible than when it is unintelligible (e.g. backward speech). This top-down control leads to a better tracking of the speech envelope by the auditory cortex activity^{68,69}, suggesting that motor areas help enhance auditory temporal prediction during speech processing⁵⁰.

In recent MEG research where participants passively listened to rhythmic strings of syllables⁷⁰, the synchronization between auditory and motor regions was found to be highest when syllables were presented at a rate of 4.5 syllables per second (Figure 5), corresponding to the mean syllable rate of natural speech across languages⁷¹. One plausible explanation is that speech production regions behave as a neural oscillator — a system capable of generating oscillations at its own natural frequency and showing entrainment to a rhythmic stimulus only if the external frequency is close to its natural one⁷² — with a natural frequency close to 4.5 Hz. Thus, the temporal patterns of speech could emerge as a consequence of the intrinsic rhythms of cortical areas.

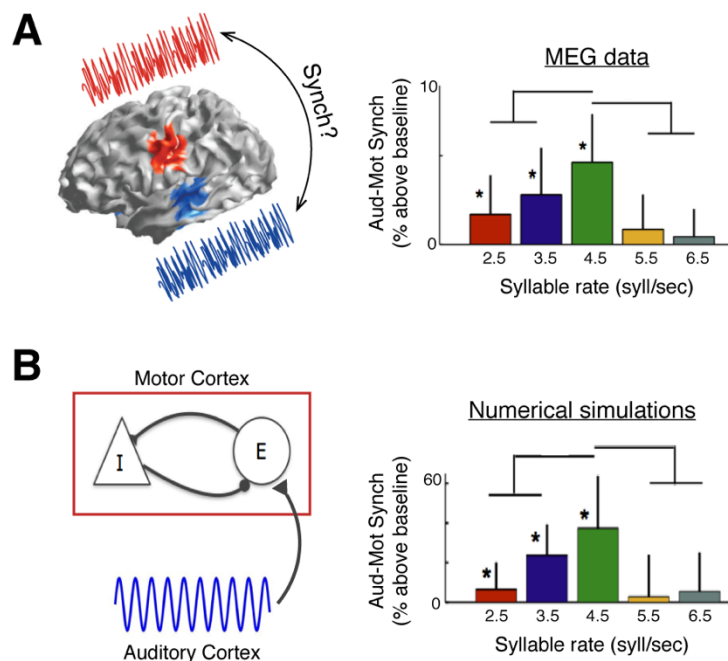

Figure 5. Auditory-motor synchronization during speech perception. (A) Experimental data. Motor (red) and auditory (blue) cortical activity were recorded while participants passively listened to rhythmic train of syllables at different rates. The synchronization between cortices significantly increased from baseline just if syllables were presented at 2.5, 3.5 and 4.5 syllables/sec and was enhanced at the central condition (4.5 syllable/sec). (B) Model output. Motor cortex (red box) was modeled through a set of Wilson-Cowan equations representing an inhibitory-excitatory network, and the excitatory population receives the auditory cortex activity (blue signal) as input.

The Wilson-Cowan is a biophysically inspired model, which behaves as a neural oscillator. Numerical simulation obtained by setting the natural frequency of the oscillator at 4.5 Hz reproduced the experimental pattern of auditory-motor synchrony. Figure adapted, with permission, from Assaneo MF, Poeppel D. The coupling between auditory and motor cortices is rate-restricted: Evidence for an intrinsic speech-motor rhythm. *Science Advances*. 2018;4(2).

Decoding approaches in language research

Another approach that has gained popularity in recent years is “multivariate” or “decoding” analyses. For MEG, this typically involves using the activity pattern across all sensors (not just one location at a time; hence, “multi-” variate), in order to read out the stimulus property as it is

encoded in the neural response (hence, “decoding”). The algorithms for this approach have been largely borrowed from the machine-learning community, and can provide an increased sensitivity in situations where the neural processes do not necessarily evoke a strong focal amplitude modulation. For example, evidence from a decoding analysis on EEG-MEG data aimed at differentiating responses to words of different semantic categories (e.g. living vs. non-living), suggests that relevant responses are not only highly distributed across space, but also vary in timing⁷³. Further, a recent study demonstrated the ability to decode the identity of a word, before it begins, when that word is highly predictable in context⁵³. This was achieved by examining the spatial pattern of brain activity prior to the presentation of predicted words. Overall, these studies show that applying multivariate analysis to the MEG data paves the way for studying language processing in cases where classic evoked-responses analysis would not be sensitive to the true underlying processing differences.

Clinical relevance: dyslexia and specific language impairment

Disrupted evoked responses to speech and text has been associated with several language deficits. For example, dyslexic participants exhibit atypical early evoked responses to letters⁷⁴, and N400m responses measured in infancy can predict reading speed in adolescence for children at risk for dyslexia⁷⁵. Disruption of early neural processing to speech sounds has also been linked to dyslexia, as well as specific language impairment (SLI)^{76,77}.

The study of neural oscillations and their link to speech and language disorders is also receiving increasing interest. Hearing impairment affects alpha oscillations and speech-brain synchronization; both oscillatory deficits are associated with the degree of hearing loss in noisy environments⁷⁸. Dyslexia and SLI have been proposed to originate from abnormal neural oscillatory profiles in response to speech^{79,80}: children who have inefficient brain-to-speech synchronization may have a harder time segmenting the acoustic signal, leading to language difficulties^{81,82}. Dyslexics show stronger synchronization to fast auditory rhythms in the gamma range (40 Hz) as compared to controls, suggesting disrupted auditory timing processing for phoneme perception⁸³. Brain synchronization to the slower dynamics of the speech envelope is also disrupted in dyslexia and SLI^{84–86}.

To remediate language deficits, rhythm training programs have been tested to improve speech timing perception based on finger-tapping or musical exposure^{87,88}. Finger-tapping and musical exposure have both been associated with increased recruitment of neural oscillations^{89,90}. Ongoing research is currently investigating the direct link between neural oscillatory activity and speech perception improvement during training.

References

1. Tarkiainen A, Helenius P, Hansen PC, Cornelissen PL, Salmelin R. Dynamics of letter string perception in the human occipitotemporal cortex. *Brain*. 1999;122 (Pt 11):2119-2132.
2. Pylkkänen L, Marantz A. Tracking the time course of word recognition with MEG. *Trends Cogn Sci*. 2003;7(5):187-189. doi:10.1016/s1364-6613(03)00092-5
3. Gwilliams L, Lewis GA, Marantz A. Functional characterisation of letter-specific responses in time, space and current polarity using magnetoencephalography. *Neuroimage*. 2016;132:320-333.
4. Dikker S, Rabagliati H, Pylkkänen L. Sensitivity to syntax in visual cortex. *Cognition*. 2009;110(3):293-321.
5. Zweig E, Pylkkänen L. A visual M170 effect of morphological complexity. *Lang Cogn Process*. 2009;24(3):412-439.
6. McCandliss BD, Cohen L, Dehaene S. The visual word form area: expertise for reading in the fusiform gyrus. *Trends Cogn Sci*. 2003;7(7):293-299.
7. Chang EF, Rieger JW, Johnson K, Berger MS, Barbaro NM, Knight RT. Categorical speech representation in human superior temporal gyrus. *Nat Neurosci*. 2010;13(11):1428-1432.
8. Mesgarani N, Cheung C, Johnson K, Chang EF. Phonetic feature encoding in human superior temporal gyrus. *Science*. 2014;343(6174):1006-1010.
9. Di Liberto GM, O'Sullivan JA, Lalor EC. Low-Frequency Cortical Entrainment to Speech Reflects Phoneme-Level Processing. *Curr Biol*. 2015;25(19):2457-2465.
10. Gwilliams L, Poeppel D, Marantz A, Linzen T. Phonological (un)certainly weights lexical activation. *Proceedings of the 8th Workshop on Cognitive Modeling and Computational Linguistics (CMCL 2018)*. 2018. doi:10.18653/v1/w18-0104
11. Gwilliams L, Linzen T, Poeppel D, Marantz A. In Spoken Word Recognition, the Future Predicts the Past. *J Neurosci*. 2018;38(35):7585-7599.
12. Ettinger A, Linzen T, Marantz A. The role of morphology in phoneme prediction: evidence from MEG. *Brain Lang*. 2014;129:14-23.
13. Gwilliams L, Marantz A. Non-linear processing of a linear speech stream: The influence of morphological structure on the recognition of spoken Arabic words. *Brain Lang*. 2015;147:1-13.

doi:10.1016/j.bandl.2015.04.006

14. Lau EF, Weber K, Gramfort A, Hämäläinen MS, Kuperberg GR. Spatiotemporal Signatures of Lexical–Semantic Prediction. *Cereb Cortex*. 2016;26(4):1377-1387. doi:10.1093/cercor/bhu219
15. Vistoli D, Passerieux C, Houze B, Hardy-Baylé M-C, Brunet-Gouet E. Neural basis of semantic priming in schizophrenia during a lexical decision task: a magneto-encephalography study. *Schizophr Res*. 2011;130(1-3):114-122.
16. Lau EF, Phillips C, Poeppel D. A cortical network for semantics: (de)constructing the N400. *Nat Rev Neurosci*. 2008;9(12):920-933.
17. Maess B, Herrmann CS, Hahne A, Nakamura A, Friederici AD. Localizing the distributed language network responsible for the N400 measured by MEG during auditory sentence processing. *Brain Research*. 2006;1096(1):163-172. doi:10.1016/j.brainres.2006.04.037
18. Wang L, Jensen O, van den Brink D, et al. Beta oscillations relate to the N400m during language comprehension. *Hum Brain Mapp*. 2012;33(12):2898-2912.
19. Kutas M, Federmeier KD. Thirty years and counting: finding meaning in the N400 component of the event-related brain potential (ERP). *Annu Rev Psychol*. 2011;62:621-647.
20. Binder JR, Desai RH, Graves WW, Conant LL. Where is the semantic system? A critical review and meta-analysis of 120 functional neuroimaging studies. *Cereb Cortex*. 2009;19(12):2767-2796.
21. Marinkovic K, Dhond RP, Dale AM, Glessner M, Carr V, Halgren E. Spatiotemporal dynamics of modality-specific and supramodal word processing. *Neuron*. 2003;38(3):487-497.
22. Halgren E, Dhond RP, Christensen N, et al. N400-like magnetoencephalography responses modulated by semantic context, word frequency, and lexical class in sentences. *Neuroimage*. 2002;17(3):1101-1116.
23. Pykkänen L, Oliveri B, Smart AJ. Semantics vs. world knowledge in prefrontal cortex. *Lang Cogn Process*. 2009;24(9):1313-1334.
24. Bedny M, McGill M, Thompson-Schill SL. Semantic adaptation and competition during word comprehension. *Cereb Cortex*. 2008;18(11):2574-2585.
25. Hagoort P, Indefrey P. The neurobiology of language beyond single words. *Annu Rev Neurosci*. 2014;37:347-362.
26. Pykkänen L, Martin AE, McElree B, Smart A. The Anterior Midline Field: coercion or decision making? *Brain Lang*. 2009;108(3):184-190.
27. Bemis DK, Pykkänen L. Simple composition: a magnetoencephalography investigation into the comprehension of minimal linguistic phrases. *J Neurosci*. 2011;31(8):2801-2814.
28. Kiehl A, Panamsky L, Links KA, Meltzer JA. Localization of electrophysiological responses to semantic and syntactic anomalies in language comprehension with MEG. *Neuroimage*. 2015;105:507-524.
29. Osterhout L, Holcomb PJ. Event-related brain potentials elicited by syntactic anomaly. *J Mem Lang*. 1992;31(6):785-806.
30. Dikker S, Rabagliati H, Farmer TA, Pykkänen L. Early occipital sensitivity to syntactic category is

based on form typicality. *Psychol Sci*. 2010;21(5):629-634.

31. Herrmann B, Maess B, Hasting AS, Friederici AD. Localization of the syntactic mismatch negativity in the temporal cortex: an MEG study. *Neuroimage*. 2009;48(3):590-600.
32. Nieuwland MS. Do “early” brain responses reveal word form prediction during language comprehension? A critical review. *Neurosci Biobehav Rev*. 2019;96:367-400.
33. Maess B, Mamashli F, Obleser J, Helle L, Friederici AD. Prediction Signatures in the Brain: Semantic Pre-Activation during Language Comprehension. *Frontiers Hum Neurosci*. 2016;10. doi:10.3389/fnhum.2016.00591
34. Lau EF, Holcomb PJ, Kuperberg GR. Dissociating N400 effects of prediction from association in single-word contexts. *J Cogn Neurosci*. 2013;25(3):484-502.
35. Brennan J, Nir Y, Hasson U, Malach R, Heeger DJ, Pylkkänen L. Syntactic structure building in the anterior temporal lobe during natural story listening. *Brain Lang*. 2012;120(2):163-173. doi:10.1016/j.bandl.2010.04.002
36. Ahissar E, Nagarajan S, Ahissar M, Protopapas A, Mahncke H, Merzenich MM. Speech comprehension is correlated with temporal response patterns recorded from auditory cortex. *Proc Natl Acad Sci U S A*. 2001;98(23):13367-13372.
37. Howard MF, Poeppel D. Discrimination of speech stimuli based on neuronal response phase patterns depends on acoustics but not comprehension. *J Neurophysiol*. 2010;104(5):2500-2511.
38. Luo H, Poeppel D. Phase patterns of neuronal responses reliably discriminate speech in human auditory cortex. *Neuron*. 2007;54(6):1001-1010.
39. Curio G, Neuloh G, Numminen J, Jousmäki V, Hari R. Speaking modifies voice-evoked activity in the human auditory cortex. *Hum Brain Mapp*. 2000;9(4):183-191.
40. Giraud A-L, Poeppel D. Cortical oscillations and speech processing: emerging computational principles and operations. *Nat Neurosci*. 2012;15(4):511-517.
41. Doelling KB, Arnal LH, Ghitza O, Poeppel D. Acoustic landmarks drive delta-theta oscillations to enable speech comprehension by facilitating perceptual parsing. *Neuroimage*. 2014;85 Pt 2:761-768.
42. Peelle JE, Gross J, Davis MH. Phase-locked responses to speech in human auditory cortex are enhanced during comprehension. *Cereb Cortex*. 2013;23(6):1378-1387.
43. Ding N, Simon JZ. Adaptive Temporal Encoding Leads to a Background-Insensitive Cortical Representation of Speech. *J Neurosci*. 2013;33(13):5728-5735. doi:10.1523/jneurosci.5297-12.2013
44. Ding N, Melloni L, Zhang H, Tian X, Poeppel D. Cortical tracking of hierarchical linguistic structures in connected speech. *Nat Neurosci*. 2016;19(1):158-164. doi:10.1038/nn.4186
45. Kösem A, Basirat A, Azizi L, van Wassenhove V. High-frequency neural activity predicts word parsing in ambiguous speech streams. *J Neurophysiol*. 2016;116(6):2497-2512.
46. Meyer L, Henry MJ, Gaston P, Schmuck N, Friederici AD. Linguistic Bias Modulates Interpretation of Speech via Neural Delta-Band Oscillations. *Cereb Cortex*. 2017;27(9):4293-4302.
47. Zion Golumbic EM, Ding N, Bickel S, et al. Mechanisms Underlying Selective Neuronal Tracking of Attended Speech at a “Cocktail Party.” *Neuron*. 2013;77(5):980-991.

48. Rimmele JM, Zion Golumbic E, Schröger E, Poeppel D. The effects of selective attention and speech acoustics on neural speech-tracking in a multi-talker scene. *Cortex*. 2015;68:144-154.
49. Riecke L, Formisano E, Sorger B, Başkent D, Gaudrain E. Neural Entrainment to Speech Modulates Speech Intelligibility. *Curr Biol*. 2018;28(2):161-169.e5.
50. Rimmele JM, Morillon B, Poeppel D, Arnal LH. Proactive Sensing of Periodic and Aperiodic Auditory Patterns. *Trends Cogn Sci*. 2018;22(10):870-882.
51. Morillon B, Schroeder CE. Neuronal oscillations as a mechanistic substrate of auditory temporal prediction. *Ann N Y Acad Sci*. 2015;1337:26-31.
52. Kösem A, Bosker HR, Takashima A, Meyer A, Jensen O, Hagoort P. Neural Entrainment Determines the Words We Hear. *Curr Biol*. 2018;28(18):2867-2875.e3.
53. Wang L, Hagoort P, Jensen O. Language Prediction Is Reflected by Coupling between Frontal Gamma and Posterior Alpha Oscillations. *J Cogn Neurosci*. 2018;30(3):432-447.
54. Lam NHL, Schoffelen J-M, Uddén J, Hultén A, Hagoort P. Neural activity during sentence processing as reflected in theta, alpha, beta, and gamma oscillations. *Neuroimage*. 2016;142:43-54.
55. Schoffelen J-M, Hultén A, Lam N, Marquand AF, Uddén J, Hagoort P. Frequency-specific directed interactions in the human brain network for language. *Proc Natl Acad Sci U S A*. 2017;114(30):8083-8088.
56. Mamashli F, Khan S, Obleser J, Friederici AD, Maess B. Oscillatory dynamics of cortical functional connections in semantic prediction. *Hum Brain Mapp*. 2019;40(6):1856-1866.
57. Keitel A, Ince RAA, Gross J, Kayser C. Auditory cortical delta-entrainment interacts with oscillatory power in multiple fronto-parietal networks. *Neuroimage*. 2017;147:32-42.
58. Liberman AM, Cooper FS, Shankweiler DP, Studdert-Kennedy M. Perception of the speech code. *Psychol Rev*. 1967;74(6):431-461.
59. Liberman AM, Mattingly IG. The motor theory of speech perception revised. *Cognition*. 1985;21(1):1-36.
60. Lane H. THE MOTOR THEORY OF SPEECH PERCEPTION: A CRITICAL REVIEW. *Psychol Rev*. 1965;72:275-309.
61. Massaro DW, Chen TH. The motor theory of speech perception revisited. *Psychon Bull Rev*. 2008;15(2):453-457; discussion 458-462.
62. Galantucci B, Fowler CA, Turvey MT. The motor theory of speech perception reviewed. *Psychon Bull Rev*. 2006;13(3):361-377.
63. Pulvermüller F, Fadiga L. Active perception: sensorimotor circuits as a cortical basis for language. *Nat Rev Neurosci*. 2010;11(5):351-360.
64. Lotto AJ, Hickok GS, Holt LL. Reflections on mirror neurons and speech perception. *Trends Cogn Sci*. 2009;13(3):110-114. doi:10.1016/j.tics.2008.11.008
65. Skipper JI, Devlin JT, Lametti DR. The hearing ear is always found close to the speaking tongue: Review of the role of the motor system in speech perception. *Brain Lang*. 2017;164:77-105.

66. Wilson SM, Saygin AP, Sereno MI, Iacoboni M. Listening to speech activates motor areas involved in speech production. *Nat Neurosci.* 2004;7(7):701-702. doi:10.1038/nn1263
67. Pulvermüller F, Huss M, Kherif F, Moscoso del Prado Martin F, Hauk O, Shtyrov Y. Motor cortex maps articulatory features of speech sounds. *Proc Natl Acad Sci U S A.* 2006;103(20):7865-7870.
68. Park H, Ince RAA, Schyns PG, Thut G, Gross J. Frontal top-down signals increase coupling of auditory low-frequency oscillations to continuous speech in human listeners. *Curr Biol.* 2015;25(12):1649-1653.
69. Park H, Thut G, Gross J. Predictive entrainment of natural speech through two fronto-motor top-down channels. *Language, Cognition and Neuroscience.* 2018:1-13. doi:10.1080/23273798.2018.1506589
70. Assaneo MF, Poeppel D. The coupling between auditory and motor cortices is rate-restricted: Evidence for an intrinsic speech-motor rhythm. *Science Advances.* 2018;4(2):eaao3842. doi:10.1126/sciadv.aao3842
71. Ding N, Patel AD, Chen L, Butler H, Luo C, Poeppel D. Temporal modulations in speech and music. *Neurosci Biobehav Rev.* 2017;81(Pt B):181-187.
72. Hoppensteadt FC, Izhikevich EM. Weakly Connected Neural Networks. *Applied Mathematical Sciences.* 1997. doi:10.1007/978-1-4612-1828-9
73. Chan AM, Halgren E, Marinkovic K, Cash SS. Decoding word and category-specific spatiotemporal representations from MEG and EEG. *Neuroimage.* 2011;54(4):3028-3039.
74. Helenius P, Tarkiainen A, Cornelissen P, Hansen PC, Salmelin R. Dissociation of normal feature analysis and deficient processing of letter-strings in dyslexic adults. *Cereb Cortex.* 1999;9(5):476-483.
75. Lohvansuu K, Hämäläinen JA, Ervast L, Lyytinen H, Leppänen PHT. Longitudinal interactions between brain and cognitive measures on reading development from 6 months to 14 years. *Neuropsychologia.* 2018;108:6-12.
76. Helenius P, Parviainen T, Paetau R, Salmelin R. Neural processing of spoken words in specific language impairment and dyslexia. *Brain.* 2009;132(Pt 7):1918-1927.
77. Renvall H, Hari R. Auditory cortical responses to speech-like stimuli in dyslexic adults. *J Cogn Neurosci.* 2002;14(5):757-768.
78. Petersen EB, WÃ¶stmann M, Obleser J, Stenfelt S, Lunner T. Hearing loss impacts neural alpha oscillations under adverse listening conditions. *Frontiers Psychol.* 2015;6. doi:10.3389/fpsyg.2015.00177
79. Goswami U. A temporal sampling framework for developmental dyslexia. *Trends Cogn Sci.* 2011;15(1):3-10.
80. Ahissar M, Lubin Y, Putter-Katz H, Banai K. Dyslexia and the failure to form a perceptual anchor. *Nat Neurosci.* 2006;9(12):1558-1564. doi:10.1038/nn1800
81. Goswami U, Cumming R, Chait M, et al. Perception of Filtered Speech by Children with Developmental Dyslexia and Children with Specific Language Impairments. *Front Psychol.* 2016;7:791.

82. Cumming R, Wilson A, Goswami U. Basic auditory processing and sensitivity to prosodic structure in children with specific language impairments: a new look at a perceptual hypothesis. *Frontiers Psychol.* 2015;6. doi:10.3389/fpsyg.2015.00972
83. Lehongre K, Ramus F, Villiermet N, Schwartz D, Giraud A-L. Altered low- γ sampling in auditory cortex accounts for the three main facets of dyslexia. *Neuron.* 2011;72(6):1080-1090.
84. Molinaro N, Lizarazu M, Lallier M, Bourguignon M, Carreiras M. Out-of-synchrony speech entrainment in developmental dyslexia. *Hum Brain Mapp.* 2016;37(8):2767-2783.
85. Soltész F, Szűcs D, Leong V, White S, Goswami U. Differential entrainment of neuroelectric delta oscillations in developmental dyslexia. *PLoS One.* 2013;8(10):e76608.
86. Leong V, Goswami U. Assessment of rhythmic entrainment at multiple timescales in dyslexia: Evidence for disruption to syllable timing. *Hearing Research.* 2014;308:141-161. doi:10.1016/j.heares.2013.07.015
87. Chern A, Tillmann B, Vaughan C, Gordon RL. New evidence of a rhythmic priming effect that enhances grammaticality judgments in children. doi:10.1101/193961
88. Bedoin N, Brisseau L, Molinier P, Roch D, Tillmann B. Temporally Regular Musical Primes Facilitate Subsequent Syntax Processing in Children with Specific Language Impairment. *Frontiers Neurosci.* 2016;10:245.
89. Nozaradan S, Peretz I, Keller PE. Individual Differences in Rhythmic Cortical Entrainment Correlate with Predictive Behavior in Sensorimotor Synchronization. *Sci Reports.* 2016;6(1). doi:10.1038/srep20612
90. Cirelli LK, Spinelli C, Nozaradan S, Trainor LJ. Measuring Neural Entrainment to Beat and Meter in Infants: Effects of Music Background. *Frontiers Neurosci.* 2016;10. doi:10.3389/fnins.2016.00229