



HAL
open science

**Lower large deviations for the maximal flow through a
domain of**

R^d

in first passage percolation

Raphaël Cerf, Marie Thérét

► **To cite this version:**

Raphaël Cerf, Marie Thérét. Lower large deviations for the maximal flow through a domain of

R^d

in first passage percolation. Probability Theory and Related Fields, 2011, 150 (3-4), pp.635-661.
10.1007/s00440-010-0287-6 . hal-03856495

HAL Id: hal-03856495

<https://hal.science/hal-03856495v1>

Submitted on 16 Nov 2022

HAL is a multi-disciplinary open access archive for the deposit and dissemination of scientific research documents, whether they are published or not. The documents may come from teaching and research institutions in France or abroad, or from public or private research centers.

L'archive ouverte pluridisciplinaire **HAL**, est destinée au dépôt et à la diffusion de documents scientifiques de niveau recherche, publiés ou non, émanant des établissements d'enseignement et de recherche français ou étrangers, des laboratoires publics ou privés.

Lower large deviations for the maximal flow through a domain of \mathbb{R}^d in first passage percolation

Raphaël Cerf

*Université Paris Sud, Mathématiques, bâtiment 425
91405 Orsay Cedex, France
E-mail: rcerf@math.u-psud.fr*

and

Marie Thérét

*École Normale Supérieure, Département Mathématiques et Applications, 45 rue d'Ulm
75230 Paris Cedex 05, France
E-mail: marie.theret@ens.fr*

Abstract: We consider the standard first passage percolation model in the rescaled graph \mathbb{Z}^d/n for $d \geq 2$, and a domain Ω of boundary Γ in \mathbb{R}^d . Let Γ^1 and Γ^2 be two disjoint open subsets of Γ , representing the parts of Γ through which some water can enter and escape from Ω . We investigate the asymptotic behaviour of the flow ϕ_n through a discrete version Ω_n of Ω between the corresponding discrete sets Γ_n^1 and Γ_n^2 . We prove that under some conditions on the regularity of the domain and on the law of the capacity of the edges, the lower large deviations of ϕ_n/n^{d-1} below a certain constant are of surface order.

AMS 2000 subject classifications: 60K35.

Keywords : First passage percolation, maximal flow, minimal cut, large deviations.

1 First definitions and main result

We use many notations introduced in [8] and [9]. Let $d \geq 2$. We consider the graph $(\mathbb{Z}_n^d, \mathbb{E}_n^d)$ having for vertices $\mathbb{Z}_n^d = \mathbb{Z}^d/n$ and for edges \mathbb{E}_n^d , the set of pairs of nearest neighbours for the standard L^1 norm. With each edge e in \mathbb{E}_n^d we associate a random variable $t(e)$ with values in \mathbb{R}^+ . We suppose that the family $(t(e), e \in \mathbb{E}_n^d)$ is independent and identically distributed, with a common law Λ : this is the standard model of first passage percolation on the graph $(\mathbb{Z}_n^d, \mathbb{E}_n^d)$. We interpret $t(e)$ as the capacity of the edge e ; it means that $t(e)$ is the maximal amount of fluid that can go through the edge e per unit of time.

We consider an open bounded connected subset Ω of \mathbb{R}^d such that the boundary $\Gamma = \partial\Omega$ of Ω is piecewise of class \mathcal{C}^1 (in particular Γ has finite area: $\mathcal{H}^{d-1}(\Gamma) < \infty$). It means that Γ is included in the union of a finite number of hypersurfaces of class \mathcal{C}^1 , i.e., in the union of a finite number of \mathcal{C}^1 submanifolds of \mathbb{R}^d of codimension 1. Let Γ^1, Γ^2 be two disjoint subsets of Γ that are open in

Γ . We want to define the maximal flow from Γ^1 to Γ^2 through Ω for the capacities $(t(e), e \in \mathbb{E}_n^d)$. We consider a discrete version $(\Omega_n, \Gamma_n, \Gamma_n^1, \Gamma_n^2)$ of $(\Omega, \Gamma, \Gamma^1, \Gamma^2)$ defined by:

$$\begin{cases} \Omega_n = \{x \in \mathbb{Z}_n^d \mid d_\infty(x, \Omega) < 1/n\}, \\ \Gamma_n = \{x \in \Omega_n \mid \exists y \notin \Omega_n, \langle x, y \rangle \in \mathbb{E}_n^d\}, \\ \Gamma_n^i = \{x \in \Gamma_n \mid d_\infty(x, \Gamma^i) < 1/n, d_\infty(x, \Gamma^{3-i}) \geq 1/n\} \text{ for } i = 1, 2, \end{cases}$$

where d_∞ is the L^∞ -distance, the notation $\langle x, y \rangle$ corresponds to the edge of endpoints x and y (see figure 1).

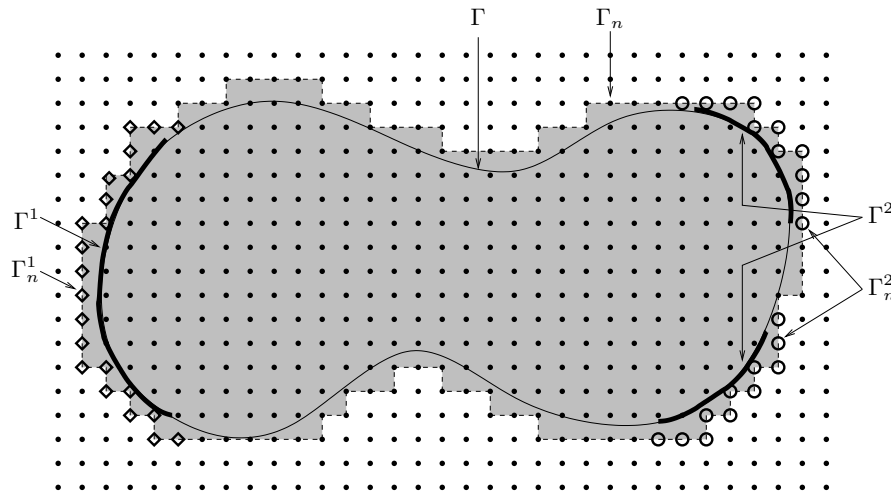

Figure 1: Domain Ω .

We shall study the maximal flow from Γ_n^1 to Γ_n^2 in Ω_n . Let us define properly the maximal flow $\phi(F_1 \rightarrow F_2 \text{ in } C)$ from F_1 to F_2 in C , for $C \subset \mathbb{R}^d$ (or by commodity the corresponding graph $C \cap \mathbb{Z}^d/n$). We will say that an edge $e = \langle x, y \rangle$ belongs to a subset A of \mathbb{R}^d , which we denote by $e \in A$, if the interior of the segment joining x to y is included in A . We define $\tilde{\mathbb{E}}_n^d$ as the set of all the oriented edges, i.e., an element \tilde{e} in $\tilde{\mathbb{E}}_n^d$ is an ordered pair of vertices which are nearest neighbours. We denote an element $\tilde{e} \in \tilde{\mathbb{E}}_n^d$ by $\langle\langle x, y \rangle\rangle$, where $x, y \in \mathbb{Z}_n^d$ are the endpoints of \tilde{e} and the edge is oriented from x towards y . We consider the set \mathcal{S} of all pairs of functions (g, o) , with $g : \mathbb{E}_n^d \rightarrow \mathbb{R}^+$ and $o : \mathbb{E}_n^d \rightarrow \tilde{\mathbb{E}}_n^d$ such that $o(\langle x, y \rangle) \in \{\langle\langle x, y \rangle\rangle, \langle\langle y, x \rangle\rangle\}$, satisfying:

- for each edge e in C we have

$$0 \leq g(e) \leq t(e),$$

- for each vertex v in $C \setminus (F_1 \cup F_2)$ we have

$$\sum_{e \in C : o(e) = \langle\langle v, \cdot \rangle\rangle} g(e) = \sum_{e \in C : o(e) = \langle\langle \cdot, v \rangle\rangle} g(e),$$

where the notation $o(e) = \langle\langle v, \cdot \rangle\rangle$ (respectively $o(e) = \langle\langle \cdot, v \rangle\rangle$) means that there exists $y \in \mathbb{Z}_n^d$ such that $e = \langle v, y \rangle$ and $o(e) = \langle\langle v, y \rangle\rangle$ (respectively $o(e) = \langle\langle y, v \rangle\rangle$). A couple $(g, o) \in \mathcal{S}$ is a possible stream in C from F_1 to F_2 : $g(e)$ is the amount of fluid that goes through the edge e , and $o(e)$ gives the direction in which the fluid goes through e . The two conditions on (g, o) express only the fact

that the amount of fluid that can go through an edge is bounded by its capacity, and that there is no loss of fluid in the graph. With each possible stream we associate the corresponding flow

$$\text{flow}(g, o) = \sum_{u \in F_2, v \notin C: \langle u, v \rangle \in \mathbb{E}_n^d} g(\langle u, v \rangle) \mathbb{1}_{o(\langle u, v \rangle) = \langle u, v \rangle} - g(\langle u, v \rangle) \mathbb{1}_{o(\langle u, v \rangle) = \langle v, u \rangle}.$$

This is the amount of fluid that crosses C from F_1 to F_2 if the fluid respects the stream (g, o) . The maximal flow through C from F_1 to F_2 is the supremum of this quantity over all possible choices of streams

$$\phi(F_1 \rightarrow F_2 \text{ in } C) = \sup\{\text{flow}(g, o) \mid (g, o) \in \mathcal{S}\}.$$

We recall that we consider an open bounded connected subset Ω of \mathbb{R}^d whose boundary Γ is piecewise of class \mathcal{C}^1 , and two disjoint open subsets Γ_1 and Γ^2 of Γ . We denote by

$$\phi_n = \phi(\Gamma_n^1 \rightarrow \Gamma_n^2 \text{ in } \Omega_n)$$

the maximal flow from Γ_n^1 to Γ_n^2 in Ω_n . We will investigate the asymptotic behaviour of ϕ_n/n^{d-1} when n goes to infinity. More precisely, we will show that the lower large deviations of ϕ_n/n^{d-1} below a constant ϕ_Ω are of surface order. The description of ϕ_Ω will be given in section 2, and $p_c(d)$ is the critical parameter for the bond percolation on \mathbb{Z}^d . Here we state the precise theorem:

Theorem 1. *If the law Λ of the capacity of an edge admits an exponential moment:*

$$\exists \theta > 0 \quad \int_{\mathbb{R}^+} e^{\theta x} d\Lambda(x) < +\infty,$$

and if $\Lambda(0) < 1 - p_c(d)$, then there exists a finite constant ϕ_Ω such that for all $\lambda < \phi_\Omega$,

$$\limsup_{n \rightarrow \infty} \frac{1}{n^{d-1}} \log \mathbb{P}[\phi_n \leq \lambda n^{d-1}] < 0.$$

Remark 1. The constant ϕ_Ω is defined in equation 1. In the two companion papers [4] and [5], we prove in fact that ϕ_Ω is the almost sure limit of ϕ_n/n^{d-1} when n goes to infinity, and that the upper large deviations of ϕ_n/n^{d-1} above ϕ_Ω are of volume order. Thus the constant ϕ_Ω is the best constant we can obtain in this theorem.

Remark 2. The lower large deviations we obtain are of the relevant order. Indeed, if all the edges in a flat layer that separates Γ_n^1 from Γ_n^2 in Ω_n have abnormally small capacity, then ϕ_n will be abnormally small. Since the cardinality of such a set of edges is $D'n^{d-1}$ for a constant D' , the probability of this event is of order $\exp -Dn^{d-1}$ for a constant D .

Remark 3. The condition $\Lambda(0) < 1 - p_c(d)$ is optimal. Indeed, Zhang proved in [11] that in the particular case where $d = 3$ and Ω is a straight cube of bottom Γ^1 and top Γ^2 , if Λ admits an exponential moment and $\Lambda(0) = 1 - p_c(d)$, then $\lim_{n \rightarrow \infty} \phi_n/n^{d-1} = 0$ a.s. The heuristic is the following: if $\Lambda(0) \geq 1 - p_c(d)$, then the edges of capacity strictly positive do not percolate, and therefore they cannot convey a strictly positive amount of fluid through Ω when n goes to infinity. Kesten obtained the first results about maximal flows in this model in [9] under a stronger hypothesis on $\Lambda(0)$. Zhang succeeded in relaxing the constraint on Λ in his remarkable article [12].

2 Computation of ϕ_Ω

2.1 Geometric notations

We start with some geometric definitions. For a subset X of \mathbb{R}^d , we denote by $\mathcal{H}^s(X)$ the s -dimensional Hausdorff measure of X (we will use $s = d - 1$ and $s = d - 2$). The r -neighbourhood $\mathcal{V}_i(X, r)$ of X for the distance d_i , that can be the Euclidean distance if $i = 2$ or the L^∞ -distance if $i = \infty$, is defined by

$$\mathcal{V}_i(X, r) = \{y \in \mathbb{R}^d \mid d_i(y, X) < r\}.$$

If X is a subset of \mathbb{R}^d included in an hyperplane of \mathbb{R}^d and of codimension 1 (for example a non degenerate hyperrectangle), we denote by $\text{hyp}(X)$ the hyperplane spanned by X , and we denote by $\text{cyl}(X, h)$ the cylinder of basis X and of height $2h$ defined by

$$\text{cyl}(X, h) = \{x + tv \mid x \in X, t \in [-h, h]\},$$

where v is one of the two unit vectors orthogonal to $\text{hyp}(X)$ (see figure 2).

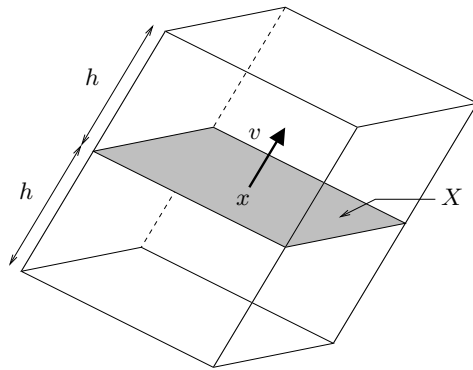

Figure 2: Cylinder $\text{cyl}(X, h)$.

For $x \in \mathbb{R}^d$, $r \geq 0$ and a unit vector v , we denote by $B(x, r)$ the closed ball centered at x of radius r , by $\text{disc}(x, r, v)$ the closed disc centered at x of radius r and normal vector v , and by $B^+(x, r, v)$ (respectively $B^-(x, r, v)$) the upper (respectively lower) half part of $B(x, r)$ where the direction is determined by v (see figure 3), i.e.,

$$B^+(x, r, v) = \{y \in B(x, r) \mid (y - x) \cdot v \geq 0\},$$

$$B^-(x, r, v) = \{y \in B(x, r) \mid (y - x) \cdot v \leq 0\}.$$

We denote by α_d the volume of a unit ball in \mathbb{R}^d , and α_{d-1} the \mathcal{H}^{d-1} measure of a unit disc.

2.2 Flow in a cylinder

Here are some particular definitions of flows through a box. It is important to know them, because all our work consists in comparing the maximal flow ϕ_n in Ω_n with the maximal flows in small cylinders. Let A be a non degenerate hyperrectangle, i.e., a box of dimension $d - 1$ in \mathbb{R}^d . All hyperrectangles will be supposed to be closed in \mathbb{R}^d . We denote by v one of the two unit vectors orthogonal to $\text{hyp}(A)$. For h a positive real number, we consider the cylinder $\text{cyl}(A, h)$. The

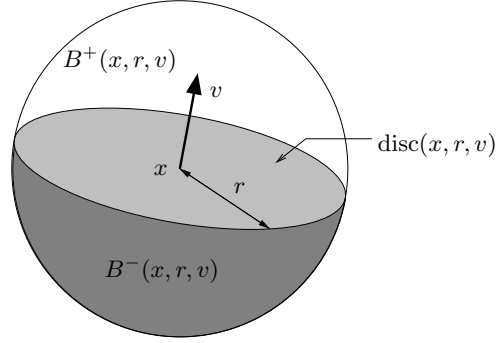
Figure 3: Ball $B(x, r)$.

set $\text{cyl}(A, h) \setminus \text{hyp}(A)$ has two connected components, which we denote by $\mathcal{C}_1(A, h)$ and $\mathcal{C}_2(A, h)$. For $i = 1, 2$, let A_i^h be the set of the points in $\mathcal{C}_i(A, h) \cap \mathbb{Z}_n^d$ which have a nearest neighbour in $\mathbb{Z}_n^d \setminus \text{cyl}(A, h)$:

$$A_i^h = \{x \in \mathcal{C}_i(A, h) \cap \mathbb{Z}_n^d \mid \exists y \in \mathbb{Z}_n^d \setminus \text{cyl}(A, h), \langle x, y \rangle \in \mathbb{E}_n^d\}.$$

Let $T(A, h)$ (respectively $B(A, h)$) be the top (respectively the bottom) of $\text{cyl}(A, h)$, i.e.,

$$T(A, h) = \{x \in \text{cyl}(A, h) \mid \exists y \notin \text{cyl}(A, h), \langle x, y \rangle \in \mathbb{E}_n^d \text{ and } \langle x, y \rangle \text{ intersects } A + hv\}$$

and

$$B(A, h) = \{x \in \text{cyl}(A, h) \mid \exists y \notin \text{cyl}(A, h), \langle x, y \rangle \in \mathbb{E}_n^d \text{ and } \langle x, y \rangle \text{ intersects } A - hv\}.$$

For a given realisation $(t(e), e \in \mathbb{E}_n^d)$ we define the variable $\tau(A, h) = \tau(\text{cyl}(A, h), v)$ by

$$\tau(A, h) = \tau(\text{cyl}(A, h), v) = \phi(A_1^h \rightarrow A_2^h \text{ in } \text{cyl}(A, h)),$$

and the variable $\phi(A, h) = \phi(\text{cyl}(A, h), v)$ by

$$\phi(A, h) = \phi(\text{cyl}(A, h), v) = \phi(B(A, h) \rightarrow T(A, h) \text{ in } \text{cyl}(A, h)),$$

where $\phi(F_1 \rightarrow F_2 \text{ in } C)$ is the maximal flow from F_1 to F_2 in C , for $C \subset \mathbb{R}^d$ (or by commodity the corresponding graph $C \cap \mathbb{Z}^d/n$) defined previously. The dependence in n is implicit here, in fact we can also write $\tau_n(A, h)$ and $\phi_n(A, h)$ if we want to emphasize this dependence on the mesh of the graph.

2.3 Max-flow min-cut theorem

The maximal flow $\phi(F_1 \rightarrow F_2 \text{ in } C)$ can be expressed differently thanks to the max-flow min-cut theorem (see [2]). We need some definitions to state this result. A path on the graph \mathbb{Z}_n^d from v_0 to v_m is a sequence $(v_0, e_1, v_1, \dots, e_m, v_m)$ of vertices v_0, \dots, v_m alternating with edges e_1, \dots, e_m such that v_{i-1} and v_i are neighbours in the graph, joined by the edge e_i , for i in $\{1, \dots, m\}$. A set E of edges in C is said to cut F_1 from F_2 in C if there is no path from F_1 to F_2 in $C \setminus E$. We call E an

(F_1, F_2) -cut if E cuts F_1 from F_2 in C and if no proper subset of E does. With each set E of edges we associate its capacity which is the variable

$$V(E) = \sum_{e \in E} t(e).$$

The max-flow min-cut theorem states that

$$\phi(F_1 \rightarrow F_2 \text{ in } C) = \min\{V(E) \mid E \text{ is a } (F_1, F_2)\text{-cut}\}.$$

2.4 Definition of ν

The asymptotic behaviour of the rescaled expectation of $\tau_n(A, h)$ for large n is well known, thanks to the almost subadditivity of this variable. We recall the following result:

Theorem 2. *We suppose that*

$$\int_{[0, +\infty[} x d\Lambda(x) < \infty.$$

Then for each unit vector v there exists a constant $\nu(d, \Lambda, v) = \nu(v)$ (the dependence on d and Λ is implicit) such that for every non degenerate hyperrectangle A orthogonal to v and for every strictly positive constant h , we have

$$\lim_{n \rightarrow \infty} \frac{\mathbb{E}[\tau_n(A, h)]}{n^{d-1} \mathcal{H}^{d-1}(A)} = \nu(v).$$

For a proof of this proposition, see [10]. We emphasize the fact that the limit depends on the direction of v , but not on h nor on the hyperrectangle A itself.

In fact, Rossignol and Th  ret proved in [10] that under some moment conditions and/or some condition on A , $\nu(v)$ is the limit of the rescaled variable $\tau_n(A, h)/(n^{d-1} \mathcal{H}^{d-1}(A))$ almost surely and in L^1 . We also know, thanks to the works of Kesten [9], Zhang [12] and Rossignol and Th  ret [10] that the variable $\phi_n(A, h)/(n^{d-1} \mathcal{H}^{d-1}(A))$ satisfies the same law of large numbers in the particular case where A is a straight hyperrectangle, i.e., a hyperrectangle of the form $\prod_{i=1}^{d-1} [0, k_i] \times \{0\}$ for some $k_i > 0$. In his article [12], Zhang obtains a control on the number of edges in a minimal cutset. We will present and use this result in section 4.

We recall some geometric properties of the map $\nu : v \in S^{d-1} \mapsto \nu(v)$, under the only condition on Λ that $\mathbb{E}(t(e)) < \infty$. They have been stated in section 4.4 of [10]. There exists a unit vector v_0 such that $\nu(v_0) = 0$ if and only if for all unit vector v , $\nu(v) = 0$, and it happens if and only if $\Lambda(0) \geq 1 - p_c(d)$. This property has been proved by Zhang in [11]. Moreover, ν satisfies the weak triangle inequality, i.e., if (ABC) is a non degenerate triangle in \mathbb{R}^d and v_A , v_B and v_C are the exterior normal unit vectors to the sides $[BC]$, $[AC]$, $[AB]$ in the plane spanned by A , B , C , then

$$\mathcal{H}^1([AB])\nu(v_C) \leq \mathcal{H}^1([AC])\nu(v_B) + \mathcal{H}^1([BC])\nu(v_A).$$

This implies that the homogeneous extension ν_0 of ν to \mathbb{R}^d , defined by $\nu_0(0) = 0$ and for all w in \mathbb{R}^d ,

$$\nu_0(w) = |w|_2 \nu(w/|w|_2),$$

is a convex function; in particular, since ν_0 is finite, it is continuous on \mathbb{R}^d . We denote by ν_{\min} (respectively ν_{\max}) the infimum (respectively supremum) of ν on S^{d-1} .

The last result we recall is Theorem 3.9 in [10] concerning the lower large deviations of the variable $\tau_n(A, h)$ below $\nu(v)$:

Theorem 3 (Rossignol and Th  ret). *We suppose that $\int_{[0,+\infty[} x d\Lambda(x) < \infty$ and that $\Lambda(0) < 1 - p_c(d)$. Then for every ε there exists a positive constant $K(d, \Lambda, \varepsilon)$ such that for every unit vector v and every non degenerate hyperrectangle A orthogonal to v , there exists a constant $K'(d, \Lambda, A, \varepsilon)$ such that for every strictly positive constant h we have*

$$\mathbb{P} \left[\frac{\tau_n(A, h)}{n^{d-1} \mathcal{H}^{d-1}(A)} \leq \nu(v) - \varepsilon \right] \leq K'(d, \Lambda, A, \varepsilon) \exp \left(-K(d, \Lambda, \varepsilon) n^{d-1} \mathcal{H}^{d-1}(A) \right).$$

We shall rely on this result for proving Theorem 1. Moreover, Theorem 1 is a generalisation of Theorem 3, where we work in the domain Ω instead of a parallelepiped.

2.5 Definition of ϕ_Ω

We give here a definition of ϕ_Ω in terms of the map ν . For a subset F of \mathbb{R}^d , we define the perimeter of F in Ω by

$$\mathcal{P}(F, \Omega) = \sup \left\{ \int_F \operatorname{div} f(x) d\mathcal{L}^d(x), f \in \mathcal{C}_c^\infty(\Omega, B(0, 1)) \right\},$$

where $\mathcal{C}_c^\infty(\Omega, B(0, 1))$ is the set of the functions of class \mathcal{C}^∞ from \mathbb{R}^d to $B(0, 1)$, the ball centered at 0 and of radius 1 in \mathbb{R}^d , having a compact support included in Ω , and div is the usual divergence operator. The perimeter $\mathcal{P}(F)$ of F is defined as $\mathcal{P}(F, \mathbb{R}^d)$. We denote by ∂F the boundary of F . The reduced boundary of a set of finite perimeter F , denoted by $\partial^* F$, consists of the points x of ∂F such that

- $\|\nabla_{\chi_F}\|(B(x, r)) > 0$ for any $r > 0$,
- if $w_r(x) = -\nabla_{\chi_F}(B(x, r))/\|\nabla_{\chi_F}\|(B(x, r))$ then, as r goes to 0, $w_r(x)$ converges towards a unit vector $v_F(x)$,

where χ_F is the characteristic function of F , ∇_{χ_F} is the distributional derivative of χ_F (then it is a vector Radon measure), and $\|\nabla_{\chi_F}\|$ is the total variation measure of ∇_{χ_F} . At any point x of $\partial^* F$, the vector $v_F(x)$ is also the measure theoretic exterior to F at x , i.e.,

$$\lim_{r \rightarrow 0} r^{-d} \mathcal{L}^d(B^-(x, r, v_F(x)) \setminus F) = 0 \quad \text{and} \quad \lim_{r \rightarrow 0} r^{-d} \mathcal{L}^d(B^+(x, r, v_F(x)) \cap F) = 0.$$

(For a presentation of sets of finite perimeter, see for example [6], section 13). For all $F \subset \mathbb{R}^d$ of finite perimeter in Ω , we define

$$\begin{aligned} \mathcal{I}_\Omega(F) &= \int_{\partial^* F \cap \Omega} \nu(v_F(x)) d\mathcal{H}^{d-1}(x) + \int_{\Gamma^2 \cap \partial^*(F \cap \Omega)} \nu(v_{(F \cap \Omega)}(x)) d\mathcal{H}^{d-1}(x) \\ &\quad + \int_{\Gamma^1 \cap \partial^*(\Omega \setminus F)} \nu(v_\Omega(x)) d\mathcal{H}^{d-1}(x). \end{aligned}$$

If $\mathcal{P}(F, \Omega) = +\infty$, we define $\mathcal{I}_\Omega(F) = +\infty$. Finally, we define

$$\phi_\Omega = \inf \{ \mathcal{I}_\Omega(F) \mid F \subset \mathbb{R}^d \} = \inf \{ \mathcal{I}_\Omega(F) \mid F \subset \Omega \}. \quad (1)$$

In the case where ∂F is \mathcal{C}^1 , $\mathcal{I}_\Omega(F)$ has the simpler following expression:

$$\begin{aligned} \mathcal{I}_\Omega(F) &= \int_{\partial F \cap \Omega} \nu(v_F(x)) d\mathcal{H}^{d-1}(x) + \int_{\Gamma^2 \cap \partial(F \cap \Omega)} \nu(v_{(F \cap \Omega)}(x)) d\mathcal{H}^{d-1}(x) \\ &\quad + \int_{\Gamma^1 \cap \partial(\Omega \setminus F)} \nu(v_\Omega(x)) d\mathcal{H}^{d-1}(x). \end{aligned}$$

The localization of the set along which the previous integrals are done is illustrated in figure 4. Since $\nu(v)$ is the average amount of fluid that can cross a hypersurface of area one in the direction

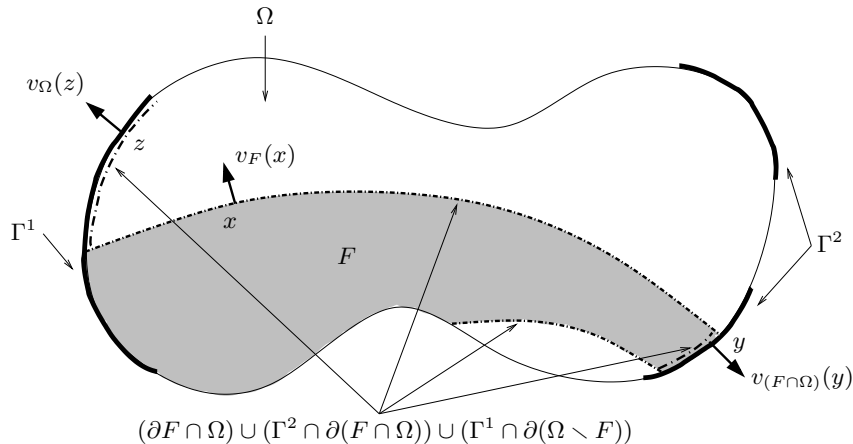

Figure 4: The set $(\partial F \cap \Omega) \cup (\Gamma^2 \cap \partial(F \cap \Omega)) \cup (\Gamma^1 \cap \partial(\Omega \setminus F))$.

v per unit of time, it can be interpreted as the capacity of a unitary hypersurface orthogonal to v . Thus $\mathcal{I}_\Omega(F)$ can be interpreted as the capacity of $(\partial F \cap \Omega) \cup (\Gamma^2 \cap \partial(F \cap \Omega)) \cup (\Gamma^1 \cap \partial(\Omega \setminus F))$.

3 Sketch of the proof

We are studying the lower large deviations of ϕ_n/n^{d-1} : they are controlled by what happens around a minimal cutset. First, we will use the estimate of the number of edges in a minimal cutset made by Zhang in [12] to restrict the problem to cutsets having a number of edges at most cn^{d-1} for a constant c ; we can then conclude that the minimal cutset is "near" the boundary of a subset F of Ω belonging to a compact space. By making an adequate covering of this space, we need only to deal with a finite number of sets and their neighbourhoods. We will then cover the boundary of such a set F by balls of very small radius, such that ∂F is "almost flat" in each ball; we will also show that if ϕ_n is smaller than $\phi_\Omega(1 - \varepsilon)n^{d-1}$ for some positive ε , then some local event happens in each ball of the covering of ∂F (this event will be denoted by $G(B, v_F(x))$ for the ball B centered at $x \in \partial F$). After that, we will construct a link between this local event in a ball and the fact that the maximal flow through a cylinder (included in the ball) is abnormally small. The lower large deviations for the maximal flow through a cylinder are already known (see [10]). Finally, we calibrate the constants to get Theorem 1.

This proof is largely inspired by the methods used to study the Wulff crystal in Ising model in dimension $d \geq 3$ (see for example [6]).

4 Number of edges in a minimal cutset and compactness

We consider a (Γ_n^1, Γ_n^2) -cut \mathcal{E}_n in Ω_n of minimal capacity, i.e., $\phi_n = V(\mathcal{E}_n)$, and of minimal number of edges (if there are more than one such cutset, we select one of them by a deterministic algorithm). According to Theorem 1 in [12], adapted to our case as said in Remark 2 in [12], we know that:

Theorem 4 (Zhang). *If the law of the capacity of the edges admits an exponential moment, and if $\Lambda(0) < 1 - p_c(d)$, then there exist constants $\beta_0 = \beta_0(\Lambda, d)$, $C_i = C_i(\Lambda, d)$ for $i = 1, 2$ and $N = N(\Lambda, d, \Omega, \Gamma, \Gamma^1, \Gamma^2)$ such that for all $\beta \geq \beta_0$, for all $n \geq N$, we have*

$$\mathbb{P}[\text{card}(\mathcal{E}_n) \geq \beta n^{d-1}] \leq C_1 \exp(-C_2 \beta n^{d-1}).$$

Remark 4. The adaptation of Zhang's result in our setting involves one difficulty: the cutsets we have to consider may not be connected. However, we can get round this problem by considering the union of a cutset with the edges that lie along Γ : it is always connected, and the number of edges we have added is bounded by cn^{d-1} for a constant c depending only on the domain Ω , since Γ is piecewise of class \mathcal{C}^1 . Then the adaptation of Zhang's proof is straightforward.

We will always consider such large $n \geq N$. Thus with high probability the (Γ_n^1, Γ_n^2) -cut \mathcal{E}_n has not "too much" edges. We want now to change a little bit our point of view in order to work with a subset of \mathbb{R}^d rather than the cutset \mathcal{E}_n . We define the set $\tilde{E}_n \subset \mathbb{Z}_n^d$ by

$$\tilde{E}_n = \{x \in \Omega_n \mid \text{there exists a path from } x \text{ to } \Gamma_n^1 \text{ made of edges that are not in } \mathcal{E}_n\}.$$

Then the edge boundary $\partial^e \tilde{E}_n$ of \tilde{E}_n , defined by

$$\partial^e \tilde{E}_n = \{e = \langle x, y \rangle \in \mathbb{Z}_n^d \cap \Omega_n \mid x \in \tilde{E}_n \text{ and } y \notin \tilde{E}_n\},$$

is exactly equal to \mathcal{E}_n . We consider now the "non discrete version" E_n of \tilde{E}_n defined by

$$E_n = \{x \in \Omega \mid d_\infty(x, \tilde{E}_n) \leq 1/(2n)\} = (\tilde{E}_n + [-1/(2n), 1/(2n)]^d) \cap \Omega.$$

For all $F \subset \mathbb{R}^d$, we recall that the perimeter of F in Ω is defined by

$$\mathcal{P}(F, \Omega) = \sup \left\{ \int_F \text{div } f(x) d\mathcal{L}^d(x), f \in \mathcal{C}_c^\infty(\Omega, B(0, 1)) \right\}.$$

We know that if $\text{card}(\mathcal{E}_n) \leq \beta n^{d-1}$, then $\mathcal{P}(E_n, \Omega) \leq \beta$.

We define

$$\mathcal{C}_\beta = \{F \subset \Omega \mid \mathcal{P}(F, \Omega) \leq \beta\},$$

endowed with the topology L^1 associated to the distance $d(F, F') = \mathcal{L}^d(F \Delta F')$, where $F \Delta F'$ is the symmetric difference between these two sets. For this topology the set \mathcal{C}_β is compact. With every F in \mathcal{C}_β we associate a positive ε_F , that we will choose later. The collection of sets $\mathcal{V}(F, \varepsilon_F)$, $F \in \mathcal{C}_\beta$, where $\mathcal{V}(F, \varepsilon_F)$ is the neighbourhood of F of size ε_F for the distance defined previously, covers \mathcal{C}_β so we can extract a finite covering: $\mathcal{C}_\beta \subset \cup_{i=1 \dots N} \mathcal{V}(F_i, \varepsilon_{F_i})$. We then obtain that for a fixed $\beta \geq \beta_0$, for all λ we have

$$\begin{aligned} \mathbb{P}[\phi_n \leq \lambda n^{d-1}] &\leq e^{-\beta n^{d-1}} + \mathbb{P}[V(\mathcal{E}_n) \leq \lambda n^{d-1} \text{ and } \mathcal{P}(E_n, \Omega) \leq \beta] \\ &\leq e^{-\beta n^{d-1}} + \sum_{i=1}^N \mathbb{P}[V(\mathcal{E}_n) \leq \lambda n^{d-1} \text{ and } \mathcal{L}^d(E_n \Delta F_i) \leq \varepsilon_i]. \end{aligned}$$

It remains to study

$$\mathbb{P}[V(\mathcal{E}_n) \leq \lambda n^{d-1} \text{ and } \mathcal{L}^d(E_n \Delta F) \leq \varepsilon_F]$$

for a generic F in \mathcal{C}_β and the corresponding ε_F .

5 Covering of ∂F by balls

5.1 Geometric tools

We recall an important result about the Minkowski content of a subset of \mathbb{R}^d (see for example Appendix A in [3]). Whenever E is a closed $(d-1)$ -rectifiable subset of \mathbb{R}^d (i.e., there exists a Lipschitz function mapping some bounded subset of \mathbb{R}^{d-1} onto E), the Minkowski content of E , defined by

$$\lim_{r \rightarrow 0} \frac{1}{2r} \mathcal{L}^d(\mathcal{V}_2(E, r)),$$

exists and is equal to $\mathcal{H}^{d-1}(E)$.

We will also use the Vitali covering theorem for \mathcal{H}^{d-1} . A collection of sets \mathcal{U} is called a Vitali class for a Borel set E of \mathbb{R}^d if for each $x \in E$ and $\delta > 0$, there exists a set $U \in \mathcal{U}$ containing x such that $0 < \text{diam } U < \delta$, where $\text{diam } U$ is the diameter of the set U . We denote by α_{d-1} the \mathcal{H}^{d-1} measure of a unit disc. We now recall the Vitali covering theorem for \mathcal{H}^{d-1} (see for instance [7], Theorem 1.10):

Theorem 5. *Let E be a \mathcal{H}^{d-1} measurable subset of \mathbb{R}^d and \mathcal{U} be a Vitali class of closed sets for E . Then we may select a (countable) disjoint sequence $(U_i)_{i \in I}$ from \mathcal{U} such that*

$$\text{either } \sum_{i \in I} (\text{diam } U_i)^{d-1} = +\infty \text{ or } \mathcal{H}^{d-1}(E \setminus \cup_{i \in I} U_i) = 0.$$

If $\mathcal{H}^{d-1}(E) < \infty$, then given $\varepsilon > 0$, we may also require that

$$\mathcal{H}^{d-1}(E) \leq \frac{\alpha_{d-1}}{2^{d-1}} \sum_{i \in I} (\text{diam } U_i)^{d-1}.$$

We recall next the Besicovitch differentiation theorem in \mathbb{R}^d (see for example [1]):

Theorem 6. *Let \mathfrak{M} be a finite positive Radon measure on \mathbb{R}^d . For any Borel function $f \in L^1(\mathfrak{M})$, the quotient*

$$\frac{1}{\mathfrak{M}(B(x, r))} \int_{B(x, r)} f(y) d\mathfrak{M}(y)$$

converges \mathfrak{M} -almost surely towards $f(x)$ as r goes to 0.

We denote by α_d the volume of a unit ball in \mathbb{R}^d . We state a result of covering that we will use in our study of the lower deviations of ϕ_n :

Lemma 1. *Let F be a subset of Ω of finite perimeter. For every positive constants δ and η , there exists a finite family of closed disjoint balls $(B_i)_{i \in I \cup J \cup K} = (B(x_i, r_i), v_i)_{i \in I \cup J \cup K}$ such that (the vector v_i defines B_i^-)*

$$\begin{aligned} \forall i \in I, & \quad x_i \in \partial^* F \cap \Omega, \quad r_i \in]0, 1[, \quad B_i \subset \Omega, \quad \mathcal{L}^d((F \cap B_i) \Delta B_i^-) \leq \delta \alpha_d r_i^d, \\ \forall i \in J, & \quad x_i \in \Gamma^1 \cap \partial^*(\Omega \setminus F), \quad r_i \in]0, 1[, \quad \partial \Omega \cap B_i \subset \Gamma^1, \quad \mathcal{L}^d((B_i \cap \Omega) \Delta B_i^-) \leq \delta \alpha_d r_i^d, \\ \forall i \in K, & \quad x_i \in \Gamma^2 \cap \partial^* F, \quad r_i \in]0, 1[, \quad \partial \Omega \cap B_i \subset \Gamma^2, \quad \mathcal{L}^d((F \cap B_i) \Delta B_i^-) \leq \delta \alpha_d r_i^d, \end{aligned}$$

and finally

$$\left| \mathcal{I}_\Omega(F) - \sum_{i \in I \cup K} \alpha_{d-1} r_i^{d-1} \nu(v_F(x_i)) - \sum_{i \in J} \alpha_{d-1} r_i^{d-1} \nu(v_\Omega(x_i)) \right| \leq \eta.$$

We will prove Lemma 1 with the help of Theorems 5 and 6, following the proof of Lemma 14.6 in [6]. First notice that for $F \subset \Omega$, we have

$$\begin{aligned} \mathcal{I}_\Omega(F) &= \int_{\partial^* F \cap \Omega} \nu(v_F(x)) d\mathcal{H}^{d-1}(x) + \int_{\Gamma^2 \cap \partial^* F} \nu(v_F(x)) d\mathcal{H}^{d-1}(x) \\ &\quad + \int_{\Gamma^1 \cap \partial^*(\Omega \setminus F)} \nu(v_\Omega(x)) d\mathcal{H}^{d-1}(x). \end{aligned}$$

For E a set of finite perimeter, we denote by $\|\nabla_{\chi_E}\|$ the measure defined by

$$\forall A \text{ Borel set in } \mathbb{R}^d \quad \|\nabla_{\chi_E}\|(A) = \mathcal{H}^{d-1}(A \cap \partial^* E),$$

it is equivalent to the definition of $\|\nabla_{\chi_E}\|$ given previously. We consider a subset F of Ω of finite perimeter. We recall that the function $\nu : S^{d-1} \rightarrow \mathbb{R}^+$ is continuous. The map $x \in \partial^* F \cap \Omega \mapsto v_F(x)$ is $\|\nabla_{\chi_F}\|$ -measurable, so we can apply the Besicovitch differentiation theorem in \mathbb{R}^d to the maps $x \in \partial^* F \cap \Omega \mapsto \nu(v_F(x))$ and $x \in \partial^* F \cap \Omega \mapsto 1$ to obtain that for \mathcal{H}^{d-1} -almost all $x \in \partial^* F \cap \Omega$

$$\lim_{r \rightarrow 0} \frac{1}{\alpha_{d-1} r^{d-1}} \mathcal{H}^{d-1}(B(x, r) \cap \partial^* F \cap \Omega) = 1,$$

$$\lim_{r \rightarrow 0} \frac{1}{\alpha_{d-1} r^{d-1}} \int_{B(x, r) \cap \partial^* F \cap \Omega} \nu(v_F(y)) d\mathcal{H}^{d-1}(y) = \nu(v_F(x)).$$

We denote by \mathcal{R}_1 the set of the points of $\partial^* F \cap \Omega$ where the two preceding identities hold simultaneously, thus $\mathcal{H}^{d-1}((\partial^* F \cap \Omega) \setminus \mathcal{R}_1) = 0$. Similarly, let \mathcal{R}_2 be the set of the points x belonging to $\Gamma^2 \cap \partial^* F$ such that

$$\lim_{r \rightarrow 0} \frac{1}{\alpha_{d-1} r^{d-1}} \mathcal{H}^{d-1}(B(x, r) \cap \Gamma^2 \cap \partial^* F) = 1,$$

$$\lim_{r \rightarrow 0} \frac{1}{\alpha_{d-1} r^{d-1}} \int_{B(x, r) \cap \Gamma^2 \cap \partial^* F} \nu(v_F(y)) d\mathcal{H}^{d-1}(y) = \nu(v_F(x)).$$

We also know that $\mathcal{H}^{d-1}((\Gamma^2 \cap \partial^* F) \setminus \mathcal{R}_2) = 0$. Since the map $x \in \Gamma^1 \cap \partial^*(\Omega \setminus F) \mapsto v_\Omega(x)$ is $\|\nabla_{\chi_\Omega}\|$ -measurable, the same arguments imply that the set \mathcal{R}_3 of the points x of $\Gamma^1 \cap \partial^*(\Omega \setminus F)$ such that

$$\lim_{r \rightarrow 0} \frac{1}{\alpha_{d-1} r^{d-1}} \mathcal{H}^{d-1}(B(x, r) \cap \Gamma^1 \cap \partial^*(\Omega \setminus F)) = 1,$$

$$\lim_{r \rightarrow 0} \frac{1}{\alpha_{d-1} r^{d-1}} \int_{B(x, r) \cap \Gamma^1 \cap \partial^*(\Omega \setminus F)} \nu(v_\Omega(y)) d\mathcal{H}^{d-1}(y) = \nu(v_\Omega(x)),$$

satisfies $\mathcal{H}^{d-1}(\Gamma^1 \cap \partial^*(\Omega \setminus F) \setminus \mathcal{R}_3) = 0$. Moreover, from the theory of sets of finite perimeter (see for example section 13 in [6]), we know that

$$\begin{cases} \forall x \in \partial^* F, & \lim_{r \rightarrow 0} r^{-d} \mathcal{L}^d(F \Delta B^-(x, r, v_F(x))) = 0, \\ \forall x \in \partial^*(\Omega \setminus F), & \lim_{r \rightarrow 0} r^{-d} \mathcal{L}^d(\Omega \Delta B^-(x, r, v_\Omega(x))) = 0. \end{cases}$$

We fix two parameters $\eta > 0$ and $\delta > 0$. For all $x \in \mathcal{R}_1$, there exists a positive $r(x, \eta, \delta)$ such that for all $r < r(x, \eta, \delta)$ we have

$$|\mathcal{H}^{d-1}(B(x, r) \cap \partial^* F \cap \Omega) - \alpha_{d-1} r^{d-1}| \leq \eta \alpha_{d-1} r^{d-1},$$

$$\left| \frac{1}{\alpha_{d-1}r^{d-1}} \int_{B(x,r) \cap \partial^* F \cap \Omega} \nu(v_F(y)) d\mathcal{H}^{d-1}(y) - \nu(v_F(x)) \right| \leq \eta,$$

$$\mathcal{L}^d((F \cap B(x,r)) \Delta B^-(x,r, v_F(x))) \leq \delta \alpha_d r^d \quad \text{and} \quad B(x,r) \subset \Omega.$$

For all x in \mathcal{R}_2 , there exists a positive $r(x, \eta, \delta)$ such that for all $r < r(x, \eta, \delta)$ we have

$$|\mathcal{H}^{d-1}(B(x,r) \cap \Gamma^2 \cap \partial^* F) - \alpha_{d-1}r^{d-1}| \leq \eta \alpha_{d-1}r^{d-1},$$

$$\left| \frac{1}{\alpha_{d-1}r^{d-1}} \int_{B(x,r) \cap \Gamma^2 \cap \partial^* F} \nu(v_F(y)) d\mathcal{H}^{d-1}(y) - \nu(v_F(x)) \right| \leq \eta,$$

$$\mathcal{L}^d((F \cap B(x,r)) \Delta B^-(x,r, v_F(x))) \leq \delta \alpha_d r^d \quad \text{and} \quad B(x,r) \cap \Gamma \subset \Gamma^2.$$

For all x in \mathcal{R}_3 , there exists a positive $r(x, \eta, \delta)$ such that for all $r < r(x, \eta, \delta)$ we have

$$|\mathcal{H}^{d-1}(B(x,r) \cap \Gamma^1 \cap \partial^*(\Omega \setminus F)) - \alpha_{d-1}r^{d-1}| \leq \eta \alpha_{d-1}r^{d-1},$$

$$\left| \frac{1}{\alpha_{d-1}r^{d-1}} \int_{B(x,r) \cap \Gamma^1 \cap \partial^*(\Omega \setminus F)} \nu(v_\Omega(y)) d\mathcal{H}^{d-1}(y) - \nu(v_\Omega(x)) \right| \leq \eta,$$

$$\mathcal{L}^d((\Omega \cap B(x,r)) \Delta B^-(x,r, v_F(x))) \leq \delta \alpha_d r^d \quad \text{and} \quad B(x,r) \cap \Gamma \subset \Gamma^1.$$

The family of balls

$$(B(x,r), x \in \mathcal{R}_1 \cup \mathcal{R}_2 \cup \mathcal{R}_3, r < r(x, \eta, \delta))$$

is a Vitali relation for $\mathcal{R}_1 \cup \mathcal{R}_2 \cup \mathcal{R}_3$. By the Vitali covering theorem for \mathcal{H}^{d-1} , we may select from this collection of balls a finite or countable collection of disjoint balls $B(x_i, r_i), i \in I_1$ such that either

$$\mathcal{H}^{d-1} \left((\mathcal{R}_1 \cup \mathcal{R}_2 \cup \mathcal{R}_3) \setminus \bigcup_{i \in I_1} B(x_i, r_i) \right) = 0$$

or

$$\sum_{i \in I_1} r_i^{d-1} = \infty.$$

We know that Ω and F have finite perimeter, and that

$$(\partial^* F \cap \Omega) \cup (\Gamma^2 \cap \partial^* F) \cup (\Gamma^1 \cap \partial^*(\Omega \setminus F)) \subset \Gamma \cup \partial^* F,$$

so

$$\begin{aligned} (1 - \eta) \sum_{i \in I_1} \alpha_{d-1} r_i^{d-1} &\leq \mathcal{H}^{d-1} \left((\partial^* F \cap \Omega) \cup (\Gamma^2 \cap \partial^* F) \cup (\Gamma^1 \cap \partial^*(\Omega \setminus F)) \right) \\ &\leq \mathcal{H}^{d-1}(\Gamma \cup \partial^* F) < \infty, \end{aligned}$$

thus the first case occurs in the Vitali covering theorem, so we may select a finite subset I_2 of I_1 such that

$$\mathcal{H}^{d-1} \left((\mathcal{R}_1 \cup \mathcal{R}_2 \cup \mathcal{R}_3) \setminus \bigcup_{i \in I_2} B(x_i, r_i) \right) \leq \eta \mathcal{H}^{d-1}(\mathcal{R}_1 \cup \mathcal{R}_2 \cup \mathcal{R}_3).$$

We claim that the collection of balls $(B(x_i, r_i), i \in I_2)$ enjoys the desired properties. We define the sets

$$\begin{aligned} I &= \{i \in I_2 \mid x_i \in \partial^* F \cap \Omega\}, \\ J &= \{i \in I_2 \mid x_i \in \Gamma^1 \cap \partial^*(\Omega \setminus F)\}, \\ K &= \{i \in I_2 \mid x_i \in \Gamma^2 \cap \partial^* F\}, \end{aligned}$$

and $v_i = v_F(x_i)$ for $i \in I \cup K$ and $v_i = v_\Omega(x_i)$ for $i \in J$. Finally, we only have to check that

$$\left| \mathcal{I}_\Omega(F) - \sum_{i \in I \cup K} \alpha_{d-1} r_i^{d-1} \nu(v_F(x_i)) - \sum_{i \in J} \alpha_{d-1} r_i^{d-1} \nu(v_\Omega(x_i)) \right| \leq \eta.$$

We recall that ν_{\max} is the supremum of ν over S^{d-1} ; we have

$$\begin{aligned} & \left| \mathcal{I}_\Omega(F) - \sum_{i \in I \cup K} \alpha_{d-1} r_i^{d-1} \nu(v_F(x_i)) - \sum_{i \in J} \alpha_{d-1} r_i^{d-1} \nu(v_\Omega(x_i)) \right| \\ & \leq \left| \int_{\mathcal{R}_1} \nu(v_F(y)) d\mathcal{H}^{d-1}(y) - \sum_{i \in I} \alpha_{d-1} r_i^{d-1} \nu(v_F(x_i)) \right| \\ & \quad + \left| \int_{\mathcal{R}_2} \nu(v_F(y)) d\mathcal{H}^{d-1}(y) - \sum_{i \in K} \alpha_{d-1} r_i^{d-1} \nu(v_F(x_i)) \right| \\ & \quad + \left| \int_{\mathcal{R}_3} \nu(v_\Omega(y)) d\mathcal{H}^{d-1}(y) - \sum_{i \in J} \alpha_{d-1} r_i^{d-1} \nu(v_\Omega(x_i)) \right| \\ & \leq \int_{\mathcal{R}_1 \setminus \cup_{i \in I} B(x_i, r_i)} \nu(v_F(y)) d\mathcal{H}^{d-1}(y) \\ & \quad + \sum_{i \in I} \left| \int_{\mathcal{R}_1 \cap B(x_i, r_i)} \nu(v_F(y)) d\mathcal{H}^{d-1}(y) - \alpha_{d-1} r_i^{d-1} \nu(v_F(x_i)) \right| \\ & \quad + \int_{\mathcal{R}_2 \setminus \cup_{i \in K} B(x_i, r_i)} \nu(v_F(y)) d\mathcal{H}^{d-1}(y) \\ & \quad + \sum_{i \in K} \left| \int_{\mathcal{R}_2 \cap B(x_i, r_i)} \nu(v_F(y)) d\mathcal{H}^{d-1}(y) - \alpha_{d-1} r_i^{d-1} \nu(v_F(x_i)) \right| \\ & \quad + \int_{\mathcal{R}_3 \setminus \cup_{i \in J} B(x_i, r_i)} \nu(v_\Omega(y)) d\mathcal{H}^{d-1}(y) \\ & \quad + \sum_{i \in J} \left| \int_{\mathcal{R}_3 \cap B(x_i, r_i)} \nu(v_\Omega(y)) d\mathcal{H}^{d-1}(y) - \alpha_{d-1} r_i^{d-1} \nu(v_\Omega(x_i)) \right| \\ & \leq \eta \mathcal{H}^{d-1}(\mathcal{R}_1 \cup \mathcal{R}_2 \cup \mathcal{R}_3) \nu_{\max} + \eta \sum_{i \in I \cup J \cup K} \alpha_{d-1} r_i^{d-1} \\ & \leq \eta \mathcal{H}^{d-1}(\mathcal{R}_1 \cup \mathcal{R}_2 \cup \mathcal{R}_3) \nu_{\max} + 2\eta \mathcal{H}^{d-1}(\mathcal{R}_1 \cup \mathcal{R}_2 \cup \mathcal{R}_3) \\ & \leq \eta(\nu_{\max} + 2)(\mathcal{P}(F, \Omega) + \mathcal{P}(\Omega)). \end{aligned}$$

Since $(\nu_{\max} + 2)(\mathcal{P}(F, \Omega) + \mathcal{P}(\Omega))$ does not depend on η , we have the required estimate.

5.2 Definition of a local event

We consider a set F in \mathcal{C}_β , and a positive ε_F that we have to choose adequately. Thanks to Lemma 1, we know that for every positive fixed δ and η , there exists a finite family of closed disjoint balls $(B_i)_{i \in I \cup J \cup K} = (B(x_i, r_i), v_i)_{i \in I \cup J \cup K}$ such that (the vector v_i defines B_i^-)

$$\begin{aligned} \forall i \in I, x_i \in \partial^* F \cap \Omega, r_i \in]0, 1[, B_i \subset \Omega, \mathcal{L}^d((F \cap B_i) \Delta B_i^-) &\leq \delta \alpha_d r_i^d, \\ \forall i \in J, x_i \in \Gamma^1 \cap \partial^*(\Omega \setminus F), r_i \in]0, 1[, \partial \Omega \cap B_i \subset \Gamma^1, \mathcal{L}^d((B_i \cap \Omega) \Delta B_i^-) &\leq \delta \alpha_d r_i^d, \\ \forall i \in K, x_i \in \Gamma^2 \cap \partial^* F, r_i \in]0, 1[, \partial \Omega \cap B_i \subset \Gamma^2, \mathcal{L}^d((F \cap B_i) \Delta B_i^-) &\leq \delta \alpha_d r_i^d, \end{aligned}$$

and finally

$$\left| \mathcal{I}_\Omega(F) - \sum_{i \in I \cup K} \alpha_{d-1} r_i^{d-1} \nu(v_F(x_i)) - \sum_{i \in J} \alpha_{d-1} r_i^{d-1} \nu(v_\Omega(x_i)) \right| \leq \eta,$$

where we denote by α_d the volume of a unit ball in \mathbb{R}^d , and by α_{d-1} the \mathcal{H}^{d-1} measure of a unit disc. It is obvious that $\phi_\Omega < \infty$ because

$$\phi_\Omega \leq \mathcal{I}_\Omega(\Omega) = \int_{\Gamma^2 \cap \partial^* \Omega} \nu(v_\Omega(x)) d\mathcal{H}^{d-1}(x) \leq \nu_{\max} \mathcal{H}^{d-1}(\Gamma^2) < \infty.$$

We suppose for the rest of the article that $\phi_\Omega > 0$ otherwise we do not have to study any lower large deviations. We consider $\lambda < \phi_\Omega$. There exists a positive s (we can choose it smaller than 1) such that $\lambda \leq \phi_\Omega(1 - 2s) \leq \mathcal{I}_\Omega(F)(1 - 2s)$. We choose

$$\eta = \frac{s \mathcal{I}_\Omega(F)}{4},$$

and then we obtain that

$$\begin{aligned} &\left| \mathcal{I}_\Omega(F) - \sum_{i \in I \cup K} \alpha_{d-1} r_i^{d-1} \nu(v_F(x_i)) - \sum_{i \in J} \alpha_{d-1} r_i^{d-1} \nu(v_\Omega(x_i)) \right| \\ &\leq \left(\sum_{i \in I \cup K} \alpha_{d-1} r_i^{d-1} \nu(v_F(x_i)) + \sum_{i \in J} \alpha_{d-1} r_i^{d-1} \nu(v_\Omega(x_i)) \right) \frac{s}{2}, \end{aligned}$$

and that

$$\lambda \leq \left(\sum_{i \in I \cup K} \alpha_{d-1} r_i^{d-1} \nu(v_F(x_i)) + \sum_{i \in J} \alpha_{d-1} r_i^{d-1} \nu(v_\Omega(x_i)) \right) (1 - s).$$

Since the $(B_i)_{i \in I \cup J \cup K}$ are disjoint, we also know that

$$\phi_n \geq \sum_{i \in I \cup J \cup K} V(\mathcal{E}_n \cap B_i).$$

Then

$$\begin{aligned} &\mathbb{P}[V(\mathcal{E}_n) \leq \lambda n^{d-1} \text{ and } \mathcal{L}^d(E_n \Delta F) \leq \varepsilon_F] \\ &\leq \mathbb{P} \left[\begin{array}{l} \sum_{i \in I \cup J \cup K} V(\mathcal{E}_n \cap B_i) \leq (1 - s) n^{d-1} \left(\sum_{i \in I \cup K} \alpha_{d-1} r_i^{d-1} \nu(v_F(x_i)) \right. \\ \left. + \sum_{i \in J} \alpha_{d-1} r_i^{d-1} \nu(v_\Omega(x_i)) \right) \\ \text{and } \mathcal{L}^d(E_n \Delta F) \leq \varepsilon_F \end{array} \right]. \end{aligned}$$

From now on we choose ε_F to be

$$\varepsilon_F = \min_{i \in I \cup J \cup K} \alpha_d r_i^d \delta,$$

for a fixed δ that we will choose later. For all $i \in I$, we then have

$$\mathcal{L}^d((E_n \cap B_i) \Delta B_i^-) \leq \mathcal{L}^d((F \cap B_i) \Delta B_i^-) + \mathcal{L}^d(E_n \Delta F) \leq 2\delta \alpha_d r_i^d.$$

We want to evaluate $\text{card}(((E_n \cap B_i) \Delta B_i^-) \cap \mathbb{Z}_n^d)$. It is equivalent to evaluate

$$n^d \mathcal{L}^d(((E_n \cap B_i) \Delta B_i^-) \cap \mathbb{Z}_n^d + [-1/2n, 1/2n]^d).$$

By definition, for all $x \in E_n \cap \mathbb{Z}_n^d = \widetilde{E}_n$, $x + [-1/2n, 1/2n]^d \subset E_n$, so

$$\begin{aligned} & ((E_n \cap B_i) \Delta B_i^-) \cap \mathbb{Z}_n^d + [-1/2n, 1/2n]^d \\ & \subset ((E_n \cap B_i) \Delta B_i^-) \cup (\mathcal{V}_\infty(B_i, 1/n) \setminus B_i) \cup (\mathcal{V}_\infty(B_i^-, 1/n) \setminus B_i^-) \\ & \subset ((E_n \cap B_i) \Delta B_i^-) \cup (\mathcal{V}_2(B_i, 2d/n) \setminus B_i) \cup (\mathcal{V}_2(B_i^-, 2d/n) \setminus B_i^-). \end{aligned}$$

Since ∂B_i and ∂B_i^- are very regular, the result about the Minkowski content implies that

$$\lim_{n \rightarrow \infty} \frac{n}{2d} \mathcal{L}^d(\mathcal{V}_2(B_i, 2d/n) \setminus B_i) = \mathcal{H}^{d-1}(\partial B_i)$$

and

$$\lim_{n \rightarrow \infty} \frac{n}{2d} \mathcal{L}^d(\mathcal{V}_2(B_i^-, 2d/n) \setminus B_i^-) = \mathcal{H}^{d-1}(\partial B_i^-).$$

For n large enough, we then obtain that

$$\mathcal{L}^d(((E_n \cap B_i) \Delta B_i^-) \cap \mathbb{Z}_n^d + [-1/2n, 1/2n]^d) \leq 2\delta \alpha_d r_i^d + \frac{4d(\mathcal{H}^{d-1}(\partial B_i) + \mathcal{H}^{d-1}(\partial B_i^-))}{n},$$

and then for all n large enough

$$\begin{aligned} \text{card}(((E_n \cap B_i) \Delta B_i^-) \cap \mathbb{Z}_n^d) & \leq 2\delta \alpha_d r_i^d n^d + 4d(\mathcal{H}^{d-1}(\partial B_i) + \mathcal{H}^{d-1}(\partial B_i^-)) n^{d-1} \\ & \leq 4\delta \alpha_d r_i^d n^d. \end{aligned}$$

For $i \in K$, exactly the same arguments imply that

$$\text{card}(((E_n \cap B_i) \Delta B_i^-) \cap \mathbb{Z}_n^d) \leq 4\delta \alpha_d r_i^d n^d$$

for n large enough.

We study now what happens in the balls B_i for $i \in J$. We recall that $\widetilde{E}_n = E_n \cap \mathbb{Z}_n^d$. We define $\widetilde{E}'_n = \widetilde{E}_n \cup \Omega_n^c$ (where $\Omega_n^c = \mathbb{Z}_n^d \setminus \Omega_n$) and $E'_n = \widetilde{E}'_n + [-1/(2n), 1/(2n)]^{d-1}$. Then $E'_n \cap \Omega = E_n$. In a ball B_i , we have $\partial^e \widetilde{E}'_n \cap B_i = \mathcal{E}_n \cap B_i$. Indeed, we know that $\Gamma \cap B_i \subset \Gamma^1$. The sets Γ^1 and Γ^2 are open in Γ and disjoint, so $\Gamma^1 \cap \overline{\Gamma^2} = \emptyset$, where $\overline{\Gamma^2}$ is the adherence of Γ^2 , and then $B_i \cap \overline{\Gamma^2} = \emptyset$. Since B_i is closed, we obtain that $d(B_i, \overline{\Gamma^2}) > 0$, and thus for n large enough, $\Gamma_n \cap B_i \subset \Gamma_n^1$. Moreover, we know that $\Gamma_n^1 \subset \widetilde{E}_n \subset \widetilde{E}'_n$. We obtain that $\partial^e \widetilde{E}'_n \cap \Omega_n^c \cap B_i = \emptyset$, i.e., all the edges of $\partial^e \widetilde{E}'_n$ in B_i have both endpoints in Ω_n (see figure 5). Now we have

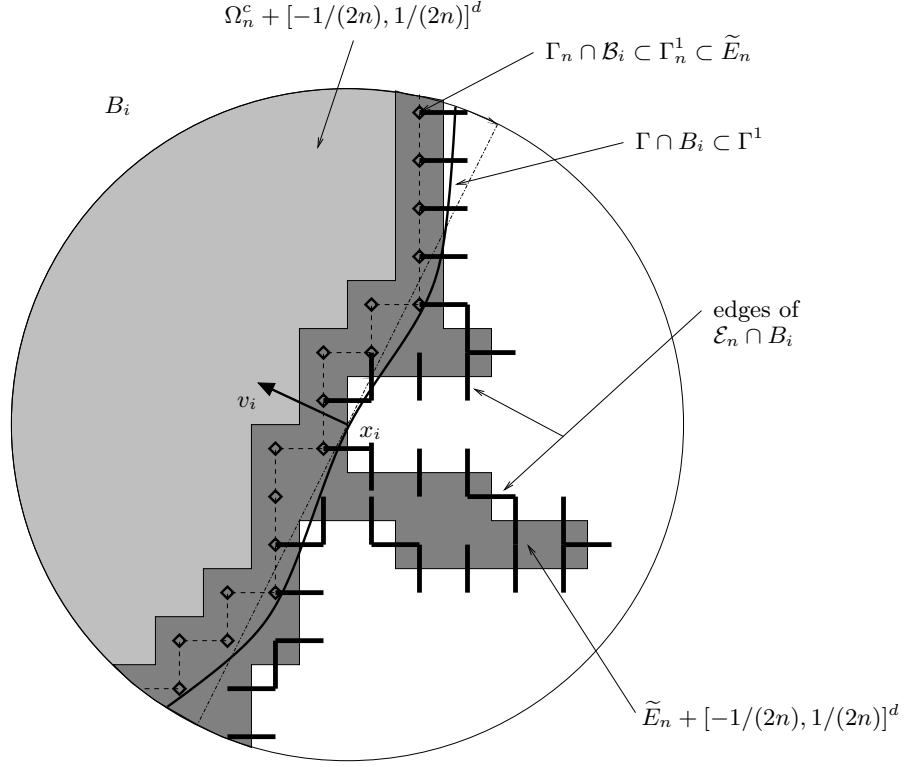
Figure 5: A ball B_i for $i \in J$.

$$\begin{aligned}
\mathcal{L}^d((E'_n \cap B_i) \Delta B_i^+) &\leq \mathcal{L}^d((E'_n \cap B_i) \Delta (\Omega^c \cap B_i)) + \mathcal{L}^d((\Omega^c \cap B_i) \Delta B_i^+) \\
&\leq \mathcal{L}^d(E'_n \cap B_i \cap \Omega) + \mathcal{L}^d((\Omega^c \setminus E'_n) \cap B_i) + \mathcal{L}^d((\Omega \cap B_i) \Delta B_i^-) \\
&\leq \mathcal{L}^d(E_n \Delta F) + \mathcal{L}^d(\mathcal{V}_\infty(\Gamma, 1/n) \cap B_i) + \delta \alpha_d r_i^d \\
&\leq \varepsilon_F + \mathcal{L}^d(\mathcal{V}_\infty(\Gamma, 1/n) \cap B_i) + \delta \alpha_d r_i^d \\
&\leq 3\delta \alpha_d r_i^d,
\end{aligned}$$

for n large enough, where the last inequality is a consequence of the properties of the Minkowski content. As previously, we obtain that for n large enough,

$$\text{card}(((E'_n \cap B_i) \Delta B_i^+) \cap \mathbb{Z}_n^d) \leq 4\delta \alpha_d r_i^d n^d.$$

We conclude that for n large enough,

$$\begin{aligned}
 & \mathbb{P}[V(\mathcal{E}_n) \leq \lambda n^{d-1} \text{ and } \mathcal{L}^d(E_n \Delta F) \leq \varepsilon_F] \\
 & \leq \sum_{i \in I} \mathbb{P} \left[\begin{array}{l} V(\partial^e \tilde{E}_n \cap B_i) \leq (1-s)\alpha_{d-1} r_i^{d-1} \nu(v_F(x_i)) \text{ and} \\ \text{card}((\tilde{E}_n \cap B_i) \Delta (B_i^- \cap \mathbb{Z}_n^d)) \leq 4\delta \alpha_d r_i^d n^d \end{array} \right] \\
 & + \sum_{i \in J} \mathbb{P} \left[\begin{array}{l} V(\partial^e \tilde{E}'_n \cap B_i) \leq (1-s)\alpha_{d-1} r_i^{d-1} \nu(v_F(x_i)) \text{ and} \\ \text{card}((\tilde{E}'_n \cap B_i) \Delta (B_i^+ \cap \mathbb{Z}_n^d)) \leq 4\delta \alpha_d r_i^d n^d \end{array} \right] \\
 & + \sum_{i \in K} \mathbb{P} \left[\begin{array}{l} V(\partial^e \tilde{E}_n \cap B_i) \leq (1-s)\alpha_{d-1} r_i^{d-1} \nu(v_F(x_i)) \text{ and} \\ \text{card}((\tilde{E}_n \cap B_i) \Delta (B_i^- \cap \mathbb{Z}_n^d)) \leq 4\delta \alpha_d r_i^d n^d \end{array} \right] \\
 & \leq \sum_{i \in I \cup J \cup K} \mathbb{P}[G(x_i, r_i, v_i)],
 \end{aligned}$$

where $G(x, r, v)$ is the event that there exists a set $U \subset B \cap \mathbb{Z}_n^d$ such that:

$$\begin{cases} \text{card}(U \Delta B^-) \leq 4\delta \alpha_d r^d n^d, \\ V(\partial^e U \cap B) \leq (\alpha_{d-1} r^{d-1} \nu(v(x)))(1-s)n^{d-1}. \end{cases}$$

Notice that this event depends only on the edges in $B = B(x, r)$. This event seems to be complicated, but indeed when $G(x, r, v)$ happens, it means in a sense that the flow between the lower half part of $B(x, r)$ (for the direction v) and the upper half part of B is abnormally small. We will examine the consequence of the event $G(x, r, v)$ over the maximal flow in $B(x, r)$ in the next section.

6 Surgery in a ball to define an almost flat cutset

We consider a fixed ball $B = B(x, r)$ and a unit vector v (corresponding to one generic ball of the previous covering). We want to interpret the event $G(x, r, v)$ in term of the maximal flow through a cylinder whose basis is a disc, included in the ball B , and oriented along the direction v . We define

$$\gamma_{\max} = \rho r,$$

where ρ is a constant depending on δ and B which we can imagine very small, it will be chosen later. The constant γ_{\max} is in fact the height of the cylinder we are constructing, namely

$$\mathcal{C} = \text{cyl}(\text{disc}(x, r', v), \gamma_{\max}).$$

We want \mathcal{C} to be included in B , so we choose

$$r' = r \cos(\arcsin \rho).$$

We would like to analyse the implication of the event $G(x, r, v)$ on the flow $\phi_{\mathcal{C}}$ between the top and the bottom of \mathcal{C} for the direction v (we will define it properly soon). As we said previously, the event $G(x, r, v)$ means that the maximal flow between a set U that "looks like" B^- (for the direction given by v) and the set U^c that "looks like" B^+ is a bit too small. Here "looks like" means that B^- and U are closed in volume, but the set U might have some thin strands (of small volume,

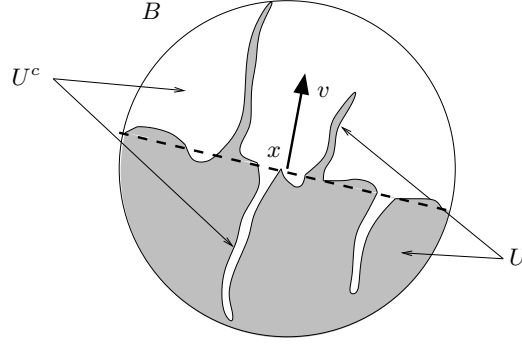
 Figure 6: Event $G(x, r, v)$.

but that can be long) that go deeply into B^+ and symmetrically the set U^c might have some thin strands that go deeply into B^- (see figure 6). What we have to do to control $\phi_{\mathcal{C}}$ is to cut these strands: by adding edges to $\partial^e U$ at a fixed height in \mathcal{C} to close the strands, we obtain a cutset in \mathcal{C} . The point is that we have to control the capacity of these edges we have added to $\partial^e U$. This is the reason why we choose the height at which we add edges to be sure we add not too many edges, and then we control their capacity thanks to a property of independence.

We suppose that the event $G(x, r, v)$ happens, and we denote by U a fixed set satisfying the properties described in the definition of $G(x, r, v)$. For each γ in $\{1/n, \dots, (\lfloor n\gamma_{\max} \rfloor - 1)/n\}$, we define

$$\begin{cases} D(\gamma) = \text{cyl}(\text{disc}(x, r', v), \gamma), \\ \partial^+ D(\gamma) = \{y \in D(\gamma) \mid \exists z \in \mathbb{Z}_n^d, (z - x) \cdot v > \gamma \text{ and } |z - y| = 1\}, \\ \partial^- D(\gamma) = \{y \in D(\gamma) \mid \exists z \in \mathbb{Z}_n^d, (z - x) \cdot v < -\gamma \text{ and } |z - y| = 1\}. \end{cases}$$

These sets are represented in figure 7. The sets $\partial^+ D(\gamma) \cup \partial^- D(\gamma)$ are pairwise disjoint for different γ , and we know that

$$\sum_{\gamma=1/n, \dots, (\lfloor n\gamma_{\max} \rfloor - 1)/n} \text{card}((\partial^+ D(\gamma) \cap U) \cup (\partial^- D(\gamma) \cap U^c)) \leq 4\delta\alpha_d r^d n^d,$$

so there exists a γ_0 in $\{1/n, \dots, (\lfloor n\gamma_{\max} \rfloor - 1)/n\}$ such that

$$\text{card}((\partial^+ D(\gamma_0) \cap U) \cup (\partial^- D(\gamma_0) \cap U^c)) \leq \frac{4\delta\alpha_d r^d n^d}{\lfloor n\gamma_{\max} \rfloor - 1} \leq \frac{5\delta\alpha_d r^d n^{d-1}}{\gamma_{\max}}$$

for n sufficiently large. We define the event $G^*(x, r, v, \gamma)$ (depending only on the edges in $D(\gamma)$) to be the existence of a set $X \subset D(\gamma) \cap \mathbb{Z}_n^d$ with the following properties:

$$\begin{cases} \text{card}((\partial^+ D(\gamma) \cap X) \cup (\partial^- D(\gamma) \cap X^c)) \leq 5\delta\alpha_d r^d n^{d-1} \gamma_{\max}^{-1} = 5\delta\alpha_d \rho^{-1} r^{d-1} n^{d-1}, \\ V(\partial^e X \cap D(\gamma)) \leq \alpha_{d-1} r^{d-1} \nu(v) (1-s) n^{d-1}. \end{cases}$$

We have proved that if $G(x, r, v)$ occurs, there exists a γ in $\{1/n, \dots, (\lfloor n\gamma_{\max} \rfloor - 1)/n\}$ such that $G^*(x, r, v, \gamma)$ happens. On $G^*(x, r, v, \gamma)$, we select a set of edges X that satisfies the properties described in the definition of $G^*(B, v(x), \gamma)$ with a deterministic procedure, and we define

$$\begin{cases} X^+ = \{\langle x, y \rangle \mid x \in \partial^+ D(\gamma) \cap X, y \notin D(\gamma)\}, \\ X^- = \{\langle x, y \rangle \mid x \in \partial^- D(\gamma) \setminus X, y \notin D(\gamma)\}. \end{cases}$$

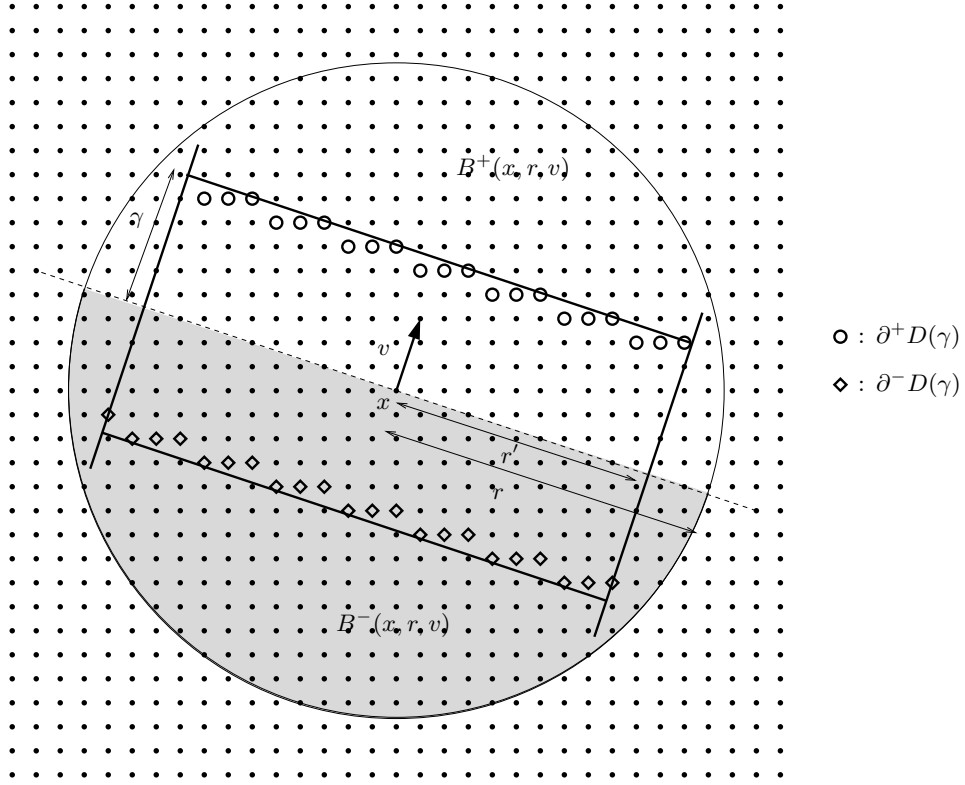
 Figure 7: Representation of $D(\gamma)$.

We claim that the set of edges $(\partial^e X \cap D(\gamma)) \cup X^+ \cup X^-$ cuts the top $\partial^+ D(\gamma_{\max})$ from the bottom $\partial^- D(\gamma_{\max})$ of $\mathcal{C} = D(\gamma_{\max})$. Indeed, consider a path r from $\partial^+ D(\gamma_{\max})$ to $\partial^- D(\gamma_{\max})$ in $D(\gamma_{\max})$, we prove now that it intersects $(\partial^e X \cap D(\gamma)) \cup X^+ \cup X^-$. We consider the intersection of this path with $D(\gamma)$. This intersection has at least one connected component that goes from $\partial^+ D(\gamma)$ to $\partial^- D(\gamma)$, we denote this reduced path by r' . If the starting point of r' belongs to X , then the edge of $r \setminus r'$ adjacent to this starting point belongs to X^+ . If the endpoint of r' belongs to X^c , then the edge of $r \setminus r'$ adjacent to this endpoint belongs to X^- . Finally, if the starting point of r' belongs to X^c and its endpoint belongs to X , then r' must contain at least one edge of $\partial^e X \cap D(\gamma)$, and so does r . We conclude that $(\partial^e X \cap D(\gamma)) \cup X^+ \cup X^-$ cuts the top $\partial^+ D(\gamma_{\max})$ from the bottom $\partial^- D(\gamma_{\max})$ of $\mathcal{C} = D(\gamma_{\max})$. If we define

$$\phi_{\mathcal{C}} = \phi(\partial^+ D(\gamma_{\max}) \rightarrow \partial^- D(\gamma_{\max}) \text{ in } \mathcal{C}),$$

on $G^*(x, r, v, \gamma)$, we have

$$\phi_{\mathcal{C}} \leq V(\partial^e X \cap D(\gamma)) + V(X^+ \cup X^-).$$

(Recall that $\partial^e X \cap D(\gamma)$ is the set of the edges of $\partial^e X$ which are included in $D(\gamma)$). Moreover

$$\begin{aligned} \text{card}(X^+ \cup X^-) &\leq 2d \text{card}((\partial^+ D(\gamma) \cap X) \cup (\partial^- D(\gamma) \setminus X)) \\ &\leq 2d \frac{5\delta\alpha dr^d n^{d-1}}{\gamma_{\max}} = Cr^{d-1} \delta \rho^{-1} n^{d-1}, \end{aligned}$$

where $C = 10d\alpha_d$ is a constant depending on the dimension. We obtain that

$$\begin{aligned} \mathbb{P}[G(x, r, v)] &\leq \sum_{\gamma=1/n, \dots, (\lfloor n\gamma_{\max} \rfloor - 1)/n} \mathbb{P}[G^*(x, r, v, \gamma)] \\ &\leq \sum_{\gamma} \mathbb{P}[G^*(x, r, v, \gamma) \cap \{V(X^+ \cup X^-) \leq \alpha_{d-1} r^{d-1} \nu(v) n^{d-1} s/4\}] \\ &\quad + \mathbb{P}[G^*(x, r, v, \gamma) \cap \{V(X^+ \cup X^-) \geq \alpha_{d-1} r^{d-1} \nu(v) n^{d-1} s/4\}]. \end{aligned}$$

On one hand, we have proved that

$$\begin{aligned} \mathbb{P}[G^*(x, r, v, \gamma) \cap \{V(X^+ \cup X^-) \leq \alpha_{d-1} r^{d-1} \nu(v) n^{d-1} s/4\}] \\ \leq \mathbb{P}[\phi_{\mathcal{C}} \leq \alpha_{d-1} r^{d-1} \nu(v) (1 - 3s/4) n^{d-1}]. \end{aligned}$$

On the other hand, we have

$$\begin{aligned} &\mathbb{P}[G^*(x, r, v, \gamma) \cap \{V(X^+ \cup X^-) \geq \alpha_{d-1} r^{d-1} \nu(v) n^{d-1} s/4\}] \\ &= \mathbb{E} \left(\mathbb{P}(G^*(x, r, v, \gamma) \cap \{V(X^+ \cup X^-) \geq \alpha_{d-1} r^{d-1} \nu(v) n^{d-1} s/4\} \mid (t(e))_{e \in D(\gamma)}) \right) \\ &= \mathbb{E} \left(\mathbb{P} \left(G^*(x, r, v, \gamma) \cap \bigcup_{F \subset \mathbb{E}_n^d} (\{X^+ \cup X^- = F\} \right. \right. \\ &\quad \left. \left. \cap \{V(F) \geq \alpha_{d-1} r^{d-1} \nu(v) n^{d-1} s/4\}) \mid (t(e))_{e \in D(\gamma)} \right) \right) \\ &\leq \mathbb{E} \left(\mathbb{1}_{G^*(x, r, v, \gamma)} \sum_{F \subset \mathbb{E}_n^d} \mathbb{1}_{\{X^+ \cup X^- = F\}} \mathbb{P}(V(F) \geq \alpha_{d-1} r^{d-1} \nu(v) n^{d-1} s/4) \right) \\ &\leq \mathbb{P} \left[\sum_{i=1}^{Cr^{d-1} \delta \rho^{-1} n^{d-1}} t_i \geq \alpha_{d-1} r^{d-1} \nu(v) n^{d-1} s/4 \right], \end{aligned}$$

where $(t_i, i \in \mathbb{N})$ is a family of i.i.d. random variables of common distribution function Λ , and the last inequality comes from the fact that for all F such that $\mathbb{P}[X^+ \cup X^- = F] > 0$, $\text{card}(F) \leq Cr^{d-1} \delta \rho^{-1} n^{d-1}$. Here we have used the following essential property of $X^+ \cup X^-$: the position of the edges of $X^+ \cup X^-$ is $\sigma(t(e), e \in D(\gamma))$ -measurable, but their capacities are independent of $(t(e))_{e \in D(\gamma)}$. Finally, we obtain that

$$\begin{aligned} \mathbb{P}[G^*(x, r, v, \gamma)] &\leq \gamma_{\max} n \mathbb{P}[\phi_{\mathcal{C}} \leq (\alpha_{d-1} r^{d-1} \nu(v)) (1 - 3s/4) n^{d-1}] \\ &\quad + \gamma_{\max} n \mathbb{P} \left[\sum_{i=1}^{Cr^{d-1} \delta \rho^{-1} n^{d-1}} t_i \geq (\alpha_{d-1} r^{d-1} \nu(v)) n^{d-1} s/4 \right], \end{aligned}$$

where $(t_i, i \in \mathbb{N})$ is a family of i.i.d. random variables of common distribution function Λ . We want to consider cylinders whose basis are hyperrectangles instead of discs, and the variable τ instead of ϕ in these cylinders, because we only know the lower large deviations of the flow in this case (see [10]). There exists a constant $c = c(d)$ such that, for any positive κ , there exists a finite family $(A_i)_{i \in I}$ of disjoint closed hyperrectangles included in $\text{disc}(x, r', v)$ such that

$$\begin{cases} \sum_{i \in I} \mathcal{H}^{d-1}(A_i) \geq \alpha_{d-1} r'^{d-1} - \kappa, \\ \sum_{i \in I} \mathcal{H}^{d-2}(\partial A_i) \leq cr'^{d-2}, \end{cases}$$

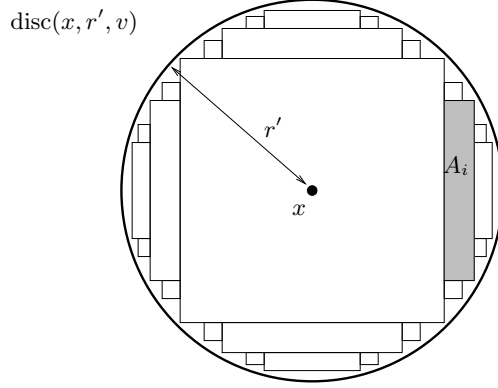
 Figure 8: $\text{disc}(x, r', v)$.

(see figure 8). Let $\mathcal{E}_{\mathcal{C}}$ be a set of edges in \mathcal{C} that cuts the top from the bottom of \mathcal{C} and such that $\phi_{\mathcal{C}} = V(\mathcal{E}_{\mathcal{C}})$. We know that such a cutset exists thanks to the max-flow min-cut Theorem. Then for all i , $\mathcal{E}_{\mathcal{C}} \cap \text{cyl}(A_i, \gamma_{\max})$ cuts the top from the bottom of $\text{cyl}(A_i, \gamma_{\max})$. We add to $\mathcal{E}_{\mathcal{C}} \cap \text{cyl}(A_i, \gamma_{\max})$ some edges along the sides of $\text{cyl}(A_i, \gamma_{\max})$ orthogonal to A_i : we define the set $\mathcal{P}_i(n) \subset \mathbb{R}^d$ by

$$\mathcal{P}_i(n) = \text{cyl}(\mathcal{V}(\partial A_i, \zeta/n) \cap \text{hyp}(A_i), \gamma_{\max}),$$

where ζ is a fixed constant bigger than $2d$, and we denote by $P_i(n)$ the set of the edges included in $\mathcal{P}_i(n)$. Then for each i , $[\mathcal{E}_{\mathcal{C}} \cap \text{cyl}(A_i, \gamma_{\max})] \cup P_i(n)$ cuts the lower half part from the upper half part of the boundary of the cylinder $\text{cyl}(A_i, \gamma_{\max})$ along the direction given by v . Thanks to the max-flow min-cut Theorem again, we obtain that

$$\sum_{i \in I} \tau(\text{cyl}(A_i, \gamma_{\max}), v) \leq \phi_{\mathcal{C}} + V(\cup_{i \in I} P_i(n)).$$

We can evaluate the number of edges in $\cup_{i \in I} P_i(n)$ as follows:

$$\text{card}(\cup_{i \in I} P_i(n)) \leq c' r'^{d-2} \gamma_{\max} n^{d-1} \leq c' \rho r^{d-1} n^{d-1},$$

where c' is a constant depending on ζ and d . Therefore, if from now on we denote by $(t_i, i \in \mathbb{N})$ a family of i.i.d. random variables of common distribution function Λ ,

$$\begin{aligned} & \mathbb{P}[\phi_{\mathcal{C}} \leq \alpha_{d-1} r^{d-1} \nu(v) (1 - 3s/4) n^{d-1}] \\ & \leq \mathbb{P} \left[\sum_{i \in I} \tau(\text{cyl}(A_i, \gamma_{\max}), v) \leq \alpha_{d-1} r^{d-1} \nu(v) (1 - s/2) n^{d-1} \right] \\ & \quad + \mathbb{P} \left[\sum_{i=1}^{c' \rho r^{d-1} n^{d-1}} t_i \geq \alpha_{d-1} r^{d-1} \nu(v) \frac{s}{4} n^{d-1} \right] \\ & \leq \mathbb{P} \left[\sum_{i \in I} \tau(\text{cyl}(A_i, \gamma_{\max}), v) \leq (1 - s/4) n^{d-1} \sum_{i \in I} \mathcal{H}^{d-1}(A_i) \nu(v) \right] \\ & \quad + \mathbb{P} \left[\sum_{i=1}^{c' \rho r^{d-1} n^{d-1}} t_i \geq \alpha_{d-1} r^{d-1} \nu(v) \frac{s}{4} n^{d-1} \right], \end{aligned}$$

as soon as the constants satisfy the condition

$$(\kappa + \alpha_{d-1}(r^{d-1} - r'^{d-1}))(1 - s/2) \leq \sum_{i \in I} \mathcal{H}^{d-1}(A_i) \nu_{\min} s/4. \quad (2)$$

Then

$$\begin{aligned} \mathbb{P}[G^*(x, r, v, \gamma)] &\leq \rho r n \sum_{i \in I} \mathbb{P}[\tau(\text{cyl}(A_i, \gamma_{\max}), v) \leq \mathcal{H}^{d-1}(A_i) \nu(v) (1 - s/4) n^{d-1}] \\ &\quad + \rho r n \mathbb{P} \left[\sum_{i=1}^{C r^{d-1} \delta \rho^{-1} n^{d-1}} t_i \geq \alpha_{d-1} r^{d-1} \nu(v) n^{d-1} s/4 \right] \\ &\quad + \rho r n \mathbb{P} \left[\sum_{i=1}^{C' \rho r^{d-1} n^{d-1}} t_i \geq \alpha_{d-1} r^{d-1} \nu(v) n^{d-1} s/4 \right]. \\ &\leq \rho r n \sum_{i \in I} \mathbb{P}[\tau(\text{cyl}(A_i, \gamma_{\max}), v) \leq \mathcal{H}^{d-1}(A_i) \nu(v) (1 - s/4) n^{d-1}] \\ &\quad + 2 \rho r n \mathbb{P} \left[\sum_{i=1}^{C'(\delta \rho^{-1} + \rho) r^{d-1} n^{d-1}} t_i \geq \alpha_{d-1} r^{d-1} \nu(v) n^{d-1} s/2 \right], \end{aligned}$$

where C' is a constant depending on ζ and d .

7 Calibration of the constants

From now on we suppose that the law Λ of the capacity of the edges admits an exponential moment. Then as soon as the constants satisfy the condition

$$C'(\rho + \delta \rho^{-1}) r^{d-1} \mathbb{E}(t(e)) < (\alpha_{d-1} r^{d-1} \nu_{\min}) \frac{s}{2}, \quad (3)$$

the Cramér Theorem in \mathbb{R} allows us to affirm that there exist positive constants \mathcal{D} and \mathcal{D}' (depending on Λ , δ , ρ , ζ , s and d) such that

$$\mathbb{P} \left[\sum_{i=1}^{C'(\delta \rho^{-1} + \rho) r^{d-1} n^{d-1}} t_i \geq (\alpha_{d-1} r^{d-1} \nu(v) n^{d-1} s/2) \right] \leq \mathcal{D}' e^{-\mathcal{D} n^{d-1}}.$$

If we also suppose that $\Lambda(0) < 1 - p_c(d)$, we know from Theorem 3 (Theorem 3.9 in [10]) that there exist a positive constant $K(d, \Lambda, s)$ and a constant $K'(d, \Lambda, A_i, s)$ such that

$$\mathbb{P}[\tau(\text{cyl}(A_i, \gamma_{\max}), v) \leq \mathcal{H}^{d-1}(A_i) \nu(v) (1 - s/4) n^{d-1}] \leq K' e^{-K n^{d-1} \mathcal{H}^{d-1}(A_i)}.$$

We have thus proved that if we can choose, for a fixed F , the constants δ , ρ and κ such that for every ball B in the collection of balls $(B_i)_{i \in I \cup J \cup K}$ the conditions (2) and (3) are satisfied, then there exists positive constants $\tilde{\mathcal{D}}$ and $\hat{\mathcal{D}}$ (depending on d , Λ , Ω , Γ^1 , Γ^2 and λ) such that

$$\mathbb{P}[\phi_n \leq \lambda n^{d-1}] \leq \hat{\mathcal{D}} e^{-\tilde{\mathcal{D}} n^{d-1}},$$

and this yields Theorem 1.

We just have to calibrate the constants. In condition (3) appears the factor $(\rho + \delta\rho^{-1})$: to make it small, we choose $\rho = \sqrt{\delta}$. Then the condition (3) is equivalent to

$$\sqrt{\delta} < \frac{\alpha_{d-1}\nu_{\min}s}{2C'\mathbb{E}(t(e))},$$

for a constant C' that depends on ζ and d , and thus it is satisfied if we choose δ small enough (clearly since $\Lambda(0) < 1 - p_c(d)$ we know that $\mathbb{E}(t(e)) > 0$ and $\nu_{\min} > 0$). To see that the condition (2) can also be satisfied, we just choose $\kappa \leq \alpha_{d-1}(r^{d-1} - r'^{d-1})/2$ (so κ depends on δ) and we remark that

$$1 - (\cos \arcsin \sqrt{\delta})^{d-1} = (d-1)\delta/2 + o(\delta),$$

so for δ small enough, condition (2) is satisfied as soon as

$$\delta \leq \frac{2\nu_{\min}}{12(d-1)(1-s/2)},$$

which can obviously be satisfied (remember that $s < 1$ and $\nu_{\min} > 0$). This ends the proof of Theorem 1.

Acknowledgement: We thank an anonymous referee for his work.

References

- [1] P. Assouad and T. Quentin de Gromard. Sur la dérivation des mesures dans \mathbb{R}^n . 1998. Unpublished note.
- [2] Béla Bollobás. *Graph theory*, volume 63 of *Graduate Texts in Mathematics*. Springer-Verlag, New York, 1979. An introductory course.
- [3] Raphaël Cerf and Ágoston Pisztora. Phase coexistence in Ising, Potts and percolation models. *Ann. Inst. H. Poincaré Probab. Statist.*, 37(6):643–724, 2001.
- [4] Raphaël Cerf and Marie Thérét. Law of large numbers for the maximal flow through a domain of \mathbb{R}^d in first passage percolation. To appear in *Transactions of the American Mathematical Society*, available from arxiv.org/abs/0907.5504, 40 pages, 2009.
- [5] Raphaël Cerf and Marie Thérét. Upper large deviations for the maximal flow through a domain of \mathbb{R}^d in first passage percolation. Available from arxiv.org/abs/0907.5499, 24 pages, 2009.
- [6] Raphaël Cerf. The Wulff crystal in Ising and percolation models. In *École d'Été de Probabilités de Saint Flour*, number 1878 in *Lecture Notes in Mathematics*. Springer-Verlag, 2006.
- [7] K. J. Falconer. *The geometry of fractal sets*, volume 85 of *Cambridge Tracts in Mathematics*. Cambridge University Press, Cambridge, 1986.
- [8] Harry Kesten. Aspects of first passage percolation. In *École d'Été de Probabilités de Saint Flour XIV*, number 1180 in *Lecture Notes in Mathematics*. Springer-Verlag, 1984.
- [9] Harry Kesten. Surfaces with minimal random weights and maximal flows: a higher dimensional version of first-passage percolation. *Illinois Journal of Mathematics*, 31(1):99–166, 1987.

-
- [10] Raphaël Rossignol and Marie Thérét. Lower large deviations and laws of large numbers for maximal flows through a box in first passage percolation. To appear in the *Annales de l'Institut Henri Poincaré - Probabilités et Statistiques*, available from arxiv.org/abs/0801.0967v2, 39 pages, 2009.
- [11] Yu Zhang. Critical behavior for maximal flows on the cubic lattice. *Journal of Statistical Physics*, 98(3-4):799–811, 2000.
- [12] Yu Zhang. Limit theorems for maximum flows on a lattice. Available from arxiv.org/abs/0710.4589, 2007.