



HAL
open science

Classical n-body scattering with long-range potentials

Jacques Fejoz, Andreas Knauf, Richard Montgomery

► **To cite this version:**

Jacques Fejoz, Andreas Knauf, Richard Montgomery. Classical n-body scattering with long-range potentials. *Nonlinearity*, 2021, 34 (11), 10.1088/1361-6544/ac288d . hal-03850550

HAL Id: hal-03850550

<https://hal.science/hal-03850550>

Submitted on 13 Nov 2022

HAL is a multi-disciplinary open access archive for the deposit and dissemination of scientific research documents, whether they are published or not. The documents may come from teaching and research institutions in France or abroad, or from public or private research centers.

L'archive ouverte pluridisciplinaire **HAL**, est destinée au dépôt et à la diffusion de documents scientifiques de niveau recherche, publiés ou non, émanant des établissements d'enseignement et de recherche français ou étrangers, des laboratoires publics ou privés.

Classical n -body scattering with long-range potentials

Jacques Fejoz* Andreas Knauf† Richard Montgomery‡

August 29, 2021

Abstract

We consider the scattering of n classical particles interacting via pair potentials, under the assumption that each pair potential is “long-range”, i.e. being of order $\mathcal{O}(r^{-\alpha})$ as r tends to infinity, for some $\alpha > 0$. We define and focus on the “free region”, the set of states leading to well-defined and well-separated final states at infinity. As a first step, we prove the existence of an explicit, global surface of section for the free region. This surface of section is key to proving the smoothness of the map sending a point to its final state and to establishing a forward conjugacy between the n -body dynamics and free dynamics.

1 Main results and set-up

1.1 Main results

Consider n classical particles moving in d -dimensional Euclidean space under the influence of a potential which is the sum of pair potentials. If the pair potentials die off appropriately at infinity then we expect that, within any widely separated fast-moving configuration of particles, the individual particles will move almost along straight lines. In this case it makes sense to talk about “scattering”. See for example [DG, Sim, He, Hu1], and [Hu2]. We will prove new facts regarding

*Ceremade, Université Paris Dauphine – PSL & IMCCE, Observatoire de Paris – PSL, jacques.fejoz@dauphine.fr

†Department of Mathematics, Friedrich-Alexander-University Erlangen-Nürnberg, Cauerstr. 11, D-91058 Erlangen, Germany, knauf@math.fau.de

‡Mathematics Department, UC Santa Cruz, 4111 McHenry, Santa Cruz, CA 95064, USA, rmont@ucsc.edu

the relation between initial conditions and scattering data at infinity. The most surprising of these is explicit criteria (1.9) which guarantee the escape to asymptotic freedom. See Theorem 1.10. Other facts, summarized by Theorems 1.12, 1.14 extend and refine results previously only known for short range potentials to the case of long-range potentials (see Definition 1.1).

1.2 Setup and notation for n -body dynamics and potential decay

A configuration q specifies the locations of all n masses, so that $q = (q_1, \dots, q_n) \in \mathbb{R}^{dn}$ with $q_a \in \mathbb{R}^d$. Thus our configuration space is

$$M := \mathbb{R}_q^{dn} \quad , \quad \text{or} \quad \widehat{M} := \mathbb{R}_q^{dn} \setminus \Delta, \quad (1.1)$$

depending on whether or not our pair potentials $V_{i,j} = V_{i,j}(q_i - q_j)$ have singularities at collision $q_i = q_j$; here

$$\Delta := \{q = (q_1, \dots, q_n) \in \mathbb{R}_q^{dn} \mid q_i = q_j \text{ for some } i \neq j\} \quad (1.2)$$

is the collision set, also known as the “fat diagonal”. Δ will also play an important role in the velocity space.

Configurations evolve in time according to Newton’s equations

$$m_i \ddot{q}_i = -\nabla_{q_i} V, \quad i = 1, \dots, n, \quad m_i > 0 \text{ the masses}, \quad (1.3)$$

which we will formulate in the usual way in phase space, using momenta $p_i = m_i \dot{q}_i$, so that $p = (p_1, \dots, p_n) \in \mathbb{R}_p^{dn}$. Thus our phase space P is

$$P := T^* M = \mathbb{R}_p^{dn} \times \mathbb{R}_q^{dn}, \quad \text{or} \quad \widehat{P} := T^* \widehat{M} = \mathbb{R}_p^{dn} \times (\mathbb{R}_q^{dn} \setminus \Delta) \quad (1.4)$$

endowed with its canonical symplectic form. Identify \mathbb{R}^{dn} with $\mathbb{R}^n \otimes \mathbb{R}^d$, let

$$\mathcal{M} := \text{diag}(m_1, \dots, m_n) \otimes \mathbb{1}_d$$

be the mass matrix, seen as an (invertible symmetric) operator on \mathbb{R}_p^{dn} . Newton’s equations can be rewritten as Hamilton’s equations

$$\dot{p} = -\nabla_q V, \quad \dot{q} = \mathcal{M}^{-1} p,$$

with Hamiltonian $H : P \rightarrow \mathbb{R}$ (or $\widehat{P} \rightarrow \mathbb{R}$),

$$H(p, q) := K(p) + V(q), \quad (1.5)$$

where the potential energy is assumed to be of the form

$$V(q) := \sum_{1 \leq i < j \leq n} V_{i,j}(q_i - q_j),$$

where the pair potentials $V_{i,j}$ satisfy $V_{j,i} = V_{i,j}$ and $V_{i,i} = 0$ for all i, j , and where K is the usual kinetic energy

$$K(p) := \sum_{i=1}^n \frac{\|p_i\|^2}{2m_i} = \frac{1}{2} \langle p, p \rangle_{\mathcal{M}^{-1}}, \quad \langle p, p' \rangle_{\mathcal{M}^{-1}} := \langle p, \mathcal{M}^{-1} p' \rangle.$$

From now on we will use multi-index notation for partial derivatives.

1.1 Definition A pair potential $V_{i,j} \in C^2(\mathbb{R}^d \setminus \{0\}, \mathbb{R})$ is

- *long range* if for some $\alpha > 0$

$$\partial^\gamma V_{i,j}(q) = \mathcal{O}(\|q\|^{-\alpha-|\gamma|}) \quad (\|q\| \rightarrow \infty, \gamma \in \mathbb{N}_0^d, |\gamma| \leq 2) \quad (1.6)$$

(if needed, $V_{i,j}$ will then also be called an α -potential),

- *short range* if (1.6) is valid for some $\alpha > 1$,
- *finite range* if the $V_{i,j}$ have bounded support.

The potential $V(q) = \sum V_{i,j}(q_i - q_j)$ is called *long range*, etc., if all its pair potentials $V_{i,j}$ have the corresponding property.

1.2 Caveats

According to this established terminology, the following implications hold:

$$\text{finite range} \implies \text{short range} \implies \text{long range}.$$

We apologize for the counterintuitive nature of the terminology. It is standard in scattering literature. Also note that a finite range potential V typically does not have bounded support within \mathbb{R}^{dn} . Rather, its support is contained in a neighborhood of the fat diagonal Δ . \diamond

1.3 Example (Celestial mechanics and electrostatics)

In celestial mechanics and electrostatics we have $V_{i,j}(Q) = \frac{I_{i,j}}{\|Q\|}$ with respectively $I_{i,j} = -m_i m_j$ and $I_{i,j} = Z_i Z_j$ for the charges $Z_i \in \mathbb{R} \setminus \{0\}$. These potentials are long range, lying on the boundary of the space of short range potentials. \diamond

1.4 Remark (Strong forces near collisions)

By definition, so-called strong force potentials satisfy

$$\partial^\gamma V_{i,j}(q) = \mathcal{O}(\|q\|^{-\alpha-|\gamma|}) \quad (\|q\| \rightarrow 0, \gamma \in \mathbb{N}_0^d, |\gamma| \leq 2), \quad (1.7)$$

for some $\alpha \geq 2$ (cf. (1.6) as $q \rightarrow \infty$). Variationally speaking, this condition is most important in the opposite "ultraviolet" regime of short distances, $\|q_i - q_j\| \ll 1$, rather than our current "infrared regime" of long distances. Imposing the strong force condition on attractive forces guarantees that any collision solution has infinite action and so is a simple way to exclude collision solutions as candidate minimizers when using the direct method of the calculus of variations to achieve various types of solutions (e.g. periodic ones) [Poi]. \diamond

1.3 Asymptotic freedom

Our first goal is to define the *free region* of phase space, leading to motions along which mutual distance eventually increase linearly with time, as in the free flow, where bodies do not interact.

This definition relies on the prior concept of asymptotic velocity.

1.5 Definition The (*forward, resp. backward*) *asymptotic shape or velocity* of a state $x \in P$ is the limit in \mathbb{R}^{dn} , if it exists, is

$$v^\pm(x) := \lim_{t \rightarrow \pm\infty} \frac{q(t)}{t},$$

where $x(t) = (q(t), p(t))$ is the integral curve through x at $t = 0$.

We are interested in motions for which $v^+ \notin \Delta$.

1.6 Definition

The state x is *forward free* if $v^+(x)$ exists and $v^+(x) \in \mathbb{R}^{dn} \setminus \Delta$. We call

$$F^+ := \{x \in P \mid v^+(x) \in \mathbb{R}^{dn} \setminus \Delta\}$$

the subset of P of forward free states. Correspondingly, the subset F^- is the set of states x which are *backward free*, i.e. $v^-(x) \in \mathbb{R}^{dn} \setminus \Delta$.

We will sometimes refer to trajectories passing through F^+ as *escape orbits*.

1.7 Remark (Clusters)

Those motions $x(t)$ for which $v^+(x)$ exists but for which $v^+(x) \in \Delta$ break up into $k < n$ clusters, each cluster composed of those particles whose indices i share a common asymptotic velocity: $v_i^+ = v_j^+$. The dynamics within a cluster of size c can be as complicated as that of the general c -body problem. The clusters interact with each other like a free k -body system. (See MARCHAL-SAARI [MS], however not in the sense of asymptotic completeness, see [DG, section 5.10].) \diamond

1.8 Example (Celestial mechanics)

CHAZY [Cha] showed that collision-free solutions for $n = 3$ gravitating bodies fall into one of seven possibilities, regarding their final behavior in the future.

- Bounded, parabolic, parabolic-elliptic and oscillating motions have zero asymptotic velocity.
- Hyperbolic-elliptic and hyperbolic-parabolic motions have asymptotic velocity belonging to $\Delta \setminus \{0\}$.
- Hyperbolic motions are free. So their asymptotic velocity is in $\mathbb{R}^{3d} \setminus \Delta$.

So, here hyperbolicity equates to freedom. For more bodies, new types of final motions occur, notably the “non-collision singularities”, see GERVER [Ge] and XIA [Xia]. But it remains true that every collision-free solution has asymptotic velocities v^\pm in both time directions provided we allow velocities to take values in the one point compactification of \mathbb{R}^{dn} [MS, Theorem 1]. (For example, for initial conditions x leading to non-collision singularities we have $\lim_{t \rightarrow T^\pm(x)} \frac{\|q(t)\|}{t} = \infty$, where $T^+(x) \in (0, \infty]$ and $T^-(x) \in [-\infty, 0)$ are the escape times beyond which the solution fails to exist.) \diamond

The precise structure of F^+ is not obvious. Yet, by flowing F^+ along integral curves, we will reach an open subset of P , which we can characterize explicitly. Let

$$\begin{cases} v_i := m_i^{-1} p_i \\ q_{i,j} := \|q_i - q_j\|, & q_{\min} := \min_{i < j} q_{i,j}, & q_{\max} := \max_{i < j} q_{i,j}, \\ v_{i,j} := \|v_i - v_j\|, & v_{\min} := \min_{i < j} v_{i,j}, & v_{\max} := \max_{i < j} v_{i,j} \end{cases}$$

and let α , δ and C be three positive parameters.

1.9 Definition The *finally free region* (with parameters α , δ and C) is

$$F_{\text{loc}}^+ := \left\{ x = (p, q) \in P \mid v_{\min}^2 > C \frac{q_{\max}}{q_{\min}^{\alpha+1}}, \right. \quad (1.8)$$

$$\left. \begin{aligned} \langle v_i - v_j, q_i - q_j \rangle &> (1 - \delta) v_{i,j} q_{i,j}, \\ (1 + 2\delta) \frac{q_{k,l}}{v_{k,l}} &> \frac{q_{i,j}}{v_{i,j}}, \quad (i \neq j, k \neq l) \end{aligned} \right\}.$$

Notations F^+ and F_{loc}^+ are meant to mimick the classical notations W^+ and W_{loc}^+ for the unstable manifold and the local unstable manifold of a hyperbolic set.

Notice that F_{loc}^+ , like F^+ , is invariant w.r.t. the symplectic lift of the diagonal action of the Euclidean group on configuration space \mathbb{R}^{dn} .

The following theorem justifies that our definition of F^+ matches our initial goal, and also justifies the notation F_{loc}^+ .

1.10 Theorem *For any long range potential V , there exist appropriate parameters α , δ and C such that F_{loc}^+ is forward invariant and such that a state $x \in P$ is in F^+ if and only if its forward orbit eventually enters F_{loc}^+ .*

The theorem follows from Theorem 2.2 below. The proof will actually show that the boundary $\partial F_{\text{loc}}^+$ is a (C^0) surface of section of the flow restricted to F^+ . Notice that $F^+ = \bigcup_{t \geq 0} \Phi_{-t}(F_{\text{loc}}^+)$, where F_{loc}^+ is open and Φ_{-t} is smooth, whence the following.

1.11 Corollary *F^+ is a non-empty open subset of P .*

The asymptotic velocity map 1.5 enjoys regularity on F^+ .

1.12 Theorem (Asymptotic velocity map on F^+)

Assume that V is a long-range potential whose pair potentials are C^k , $k \geq 2$. The map $v^+ : F^+ \rightarrow \mathbb{R}^{dn} \setminus \Delta$ is a C^{k-1} complete set of commuting first integrals. Moreover, for fixed $v_ \in \mathbb{R}^{dn} \setminus \Delta$ the space of all forward orbits $x(t)$ for which $v^+(x(t)) = v_*$ has the structure of an affine space modelled on the $(nd - 1)$ -dimensional vector space v_*^\perp .*

The regularity of the v^+ follows from item 1 of Theorem 3.3. That components of v^+ Poisson commute is clear. That v^+ is a surjective submersion, and the assertion on the structure of its fibers follows from item 4 of Theorem 5.3 below.

1.13 Earlier results (Smoothness of scattering data)

Smoothness of the scattering data and in particular of the asymptotic velocity map $x \mapsto v^+(x)$ has been achieved under various assumptions:

- In [Gu], GUTKIN proved continuity of scattering data for a class of n -particle systems on the line with repulsive interactions.
- Later, FUSCO and OLIVA proved in [FO] a result that implies smoothness of asymptotic momentum and even integrability for repulsive Coulombic potentials.
- More recently, DUIGNAN et al. [DDMMY] prove that the map $x \rightarrow v^+(x)$ is analytic on F_{loc}^+ for the Newtonian potential. \diamond

1.4 Comparison with free flows

In order to study the asymptotic behavior of the dynamics on F^+ , one strategy would be to compactify the phase space, as in [DDMMY] for the N -body problem.

Such a compactification is hard to define in full generality. Another strategy, chosen here, is to compare the dynamics to a model, integrable, free dynamics.

Write

$$\Phi : \mathbb{R}_t \times P \rightarrow P$$

for the flow defined by our n -body system. We have used the *broken arrow notation* for the map Φ to indicate that the domain of the map need not be all of $\mathbb{R}_t \times P$, thus allowing for the incomplete flows like the flows that occur for potentials such as Newton's or Coulomb's which have singularities. The curve $t \mapsto \Phi_t(x)$, where defined, is a solution to our Hamilton's equations having initial condition $x \in P$.

The *free flow* $\Phi^{(0)}$, on the other hand, is the flow whose projected curves are the lines $t \mapsto at + c$:

$$\Phi^{(0)} : \mathbb{R}_t \times P \rightarrow P \quad , \quad \Phi_t^{(0)}(p, q) = (p, q + t\mathcal{M}^{-1}p) \quad (1.9)$$

and is generated by the free Hamiltonian $H_0 = K$. Let

$$F_0 = F_0^+ := \{(p, q) \in P \mid v = \mathcal{M}^{-1}p \notin \Delta\}. \quad (1.10)$$

1.14 Theorem

Let V be a short-range (α, k) -potential with $\alpha > 1$ and $k \geq 2$ (see definition 2.1). Then the dynamics Φ on F^+ is conjugate to the free dynamics $\Phi^{(0)}$: there exists a C^{k-1} symplectomorphism $\Omega : F_0 \rightarrow F^+$ such that

$$\Omega \circ \Phi_t^{(0)} = \Phi_t \circ \Omega \quad (\forall t \geq 0).$$

This is the qualitative contents of Theorem 4.2 below.

An analogous theorem to 1.12 holds for long-range potentials. Instead of comparing the given flow with the free flow, we must compare it with an integrable, time dependent "Dollard Hamiltonian" $H_D(p, t) = K(p) + V(\sqrt{1+t^2}p)$ (which does not depend on q !). See Theorem 5.3 for precise statements.

1.15 Earlier results

In 1927 CHAZY ([Cha, Chapter 5]) used the term "hyperbolic" in the classification the long-time behaviour of solutions in the long range case of celestial mechanics. He established an analytic asymptotic expansion near infinity for his hyperbolic solutions with initial terms

$$q(t) = at + b \log(t) + c + \mathcal{O}(\log(t)/t); \quad b = +\nabla V(a) \quad \text{as } t \rightarrow \infty \quad (1.11)$$

Later, SAARI [Sa, section 8], and MARCHAL and SAARI [MS, section 10] extended and clarified Chazy's results, focussing on how cluster energies and angular momenta approach their limits. Here "cluster" refers to the situation where $v^+ \in \Delta$. The "clusters" are the subsets of mass indices i , for which $v_i^+ = v_j^+$.

The $\log(t)$ term in Chazy's expansion equation (1.11) is an essential consequence of the $1/r$ -nature of the Newtonian (or Coulomb) potential. On the other hand, hyperbolic solutions for short range potentials satisfy

$$q(t) = at + c + o(1), \quad \text{as } t \rightarrow +\infty. \quad (1.12)$$

SIMON [Sim] proved the validity of this expansion for the two-body problem using the Møller transform (as used in section 4), or, as he called it, the *wave transformation*.

Recently MADERNA and VENTURELLI [MV] investigated forward hyperbolic motions for n -body problem using variational and weak KAM methods. And DUIGNAN et al. set up [DMMY] an approach to hyperbolic motions and scattering for the n -body problem which relies on a McGehee-style compactification of phase space which adds fixed points at infinity whose stable manifold correspond to forward hyperbolic solutions. \diamond

1.5 Summary: Main notations

$v^\pm(x)$	asymptotic velocity of state x (definition 1.5)
P	phase space (equation (1.4))
\widehat{P}	phase space when collision singularities present (equation (1.4))
F^\pm	forward and backward free regions (definition 1.6)
\widehat{F}^\pm	as above, but when collision singularities present (definition (3.10))
F_{loc}^+	forward finally free region (definition 1.9)
F_0	free region of the free flow (equation (1.10))
$\Phi_t^{(0)}$	free flow (equation (1.9))
Φ_t	n -body flow (subsection 1.4)
$\widehat{\Phi}_t$	n -body flow when collisions present

2 Do we know when we are free?

For simplicity, we first consider long-range potentials V which are non-singular at the origin i.e. C^2 on \mathbb{R}^{dn} . Many properties which hold for these potentials also hold for singular long range potentials (e.g. the gravitational n -body potential). This will be proved in section 5.

We equip the real vector space of long range α -potentials $V \in C^2(\mathbb{R}^{dn}, \mathbb{R})$ (as introduced in definition 1.1, with $\alpha > 0$) with the seminorm

$$\|V\|^{(\alpha)} := \|\mathcal{M}^{-1}\| \max_{i < j \in N} \sup_{q \in \mathbb{R}^d \setminus \{0\}} \|q\|^{\alpha+1} \|\nabla V_{i,j}(q)\|. \quad (2.1)$$

Typically, pair potentials are C^2 , smoother, often even analytic. In order to describe a section of the flow in restriction to F^+ , we will need a C^2 seminorm estimate of the potential and later, scattering estimates will be improved using C^k -seminorms, with $k \in \mathbb{N}$, $k \geq 2$. We now introduce such seminorms.

2.1 Definition

An (α, k) -potential V is a potential whose pair potentials $V_{i,j} \in C^k(\mathbb{R}^d, \mathbb{R})$ fulfill

$$\partial^\gamma V_{i,j}(q) = \mathcal{O}(\|q\|^{-\alpha-|\gamma|}) \quad (\gamma \in \mathbb{N}_0^d, |\gamma| \leq k). \quad (2.2)$$

On the space of (α, k) -potentials we define

$$\|V\|^{(\alpha,k)} := \|\mathcal{M}^{-1}\| \sum_{i < j \in N} \sum_{\gamma \in \mathbb{N}_0^d, |\gamma|=k} \sup_{q \in \mathbb{R}^d \setminus \{0\}} \|q\|^{\alpha+k} |\partial^\gamma V_{i,j}(q)| \quad (2.3)$$

(so that $\|V\|^{(\alpha)} = \|V\|^{(\alpha,1)}$).

The inessential factor $\|\mathcal{M}^{-1}\| = m_{\min}^{-1}$ for $m_{\min} := \min(m_1, \dots, m_n)$ simplifies formulae.

Recall the definition of the free region

$$F^+ = \{x \in P \mid v^+(x) \in \mathbb{R}^{dn} \setminus \Delta\}. \quad (2.4)$$

It depends on the details of the (generally non-integrable) flow, and hence implicitly on the precise form of the potential V . So general properties of the free region are hard to grasp. Surprisingly, there is an explicit surface of section of the flow restricted to F^+ . It bounds a positive-invariant subset $F_{\text{loc}}^+ \subset F^+$ having the property that every orbit in F^+ must eventually enter F_{loc}^+ .

We still assume that V is a non-singular α -potential. Let δ and C with

$$0 < \delta \leq \delta_0 := \min(\alpha/(4 + \alpha), 1/5), \quad C := 16 dn \|V\|^{(\alpha,2)}/\delta.$$

Define F_{loc}^+ by (1.8), with our chosen values of α , δ and C . The three inequalities assert

- the dominance of the interparticle kinetic energy over potential energy
- the near-parallelism of interparticle distances and velocities
- that interparticle distances are nearly proportional to interparticle velocities.

This tells us what the motion of free particles eventually looks like. For example, landing in F_{loc}^+ yields the simple propagation estimates (2.5).

2.2 Theorem (Final free region)

1. F_{loc}^+ is forward invariant : $\Phi_t(F_{\text{loc}}^+) \subseteq F_{\text{loc}}^+$ for $t \geq 0$.
2. F_{loc}^+ is a subset of F^+ .
3. For any $x_0 \in F^+$ there is a time t such that $\Phi(t, x_0) \in F_{\text{loc}}^+$.
4. For $x_0 \in F_{\text{loc}}^+$ the distance between the particles $i < j \in N$ increases approximately linearly:

$$\frac{1}{2}v_{i,j}(0) t \leq q_{i,j}(t, x_0) - q_{i,j}(0, x_0) \leq \frac{3}{2}v_{i,j}(0) t \quad (t \in [0, \infty)). \quad (2.5)$$

As already mentioned, the boundary of F_{loc}^+ is thus a C^0 surface of section of the flow restricted to the free region.

2.3 Example (Two bodies) We already remarked that F_{loc}^+ is invariant under Euclidean transformations. So in particular $F_{\text{loc}}^+ = T^*\mathbb{R}^d \times \widetilde{F}_{\text{loc}}^+$, the Cartesian product referring to the separation of center of mass and internal motion.

In the case $n = 2$, in the coordinates $q_1, x = q_2 - q_1, v_1$ and $w = v_2 - v_1$ the equations of F_{loc}^+ reduce to

$$\begin{cases} w^2 > \frac{C}{\|x\|^\alpha} \\ \langle w, x \rangle > (1 - \delta) \|w\| \|x\|. \end{cases}$$

So, we see that $\widetilde{F}_{\text{loc}}^+$ (coordinates (x, w)) is fibered over $\mathbb{R}^d \setminus \{0\}$ (coordinate x), with fiber diffeomorphic to the cylinder $[1, \infty) \times S^{d-1}$ (coordinate w); see figure 2.1. \diamond

2.4 Remark (Topology of the final free region)

Although Δ is contractible, already the set $\mathbb{R}^{dn} \setminus \Delta$ to which partial F_{loc}^+ projects, is topologically rich:

1. For $d = 1$, there is a homeomorphism $\mathbb{R}^n \setminus \Delta \cong \mathbb{R}^n \times \text{Sym}(n)$.
2. For $d = 2$, the cohomology ring of $\mathbb{R}^{2n} \setminus \Delta$ is the one of the product over k of bouquets of $1 \leq k \leq n - 1$ circles, see ARNOLD [Ar]. \diamond

In order to prove Theorem 2.2, we will use the following lemma, whose proof is routine, and where we denote by $\langle \cdot \rangle$ a smoothed version of the absolute value:

$$\langle q \rangle = \sqrt{q^2 + 1}.$$

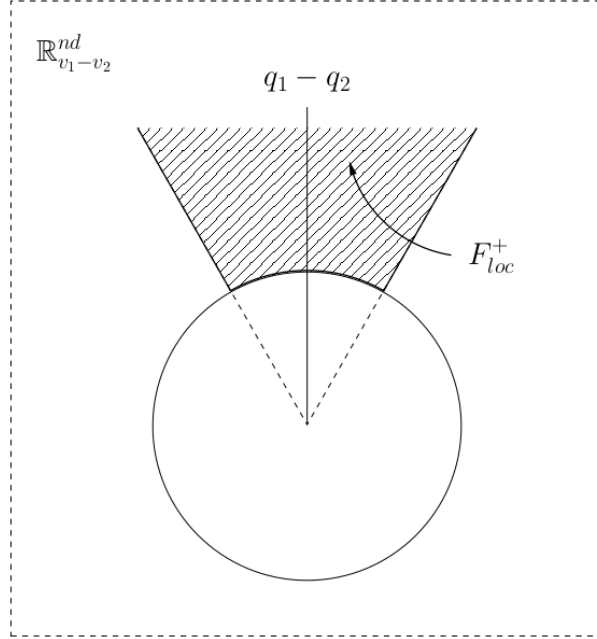

Figure 2.1: Fiber over $q_1 - q_2$ of \tilde{F}_{loc}^+ in the $n = 2$ case

2.5 Lemma

1. For $\alpha > 0$ and $q \geq 0$,

$$\frac{1}{\alpha} \langle q \rangle^{-\alpha} \leq \int_q^\infty \langle \tilde{q} \rangle^{-\alpha-1} d\tilde{q} \leq \left(\frac{1}{\alpha} + 1\right) \langle q \rangle^{-\alpha}. \quad (2.6)$$

2. If V is an α -potential (see (1.6)),

$$\|V\|^{(\alpha)} \leq \|V\|^{(\alpha,1)}$$

and, if V is an $(\alpha, k+1)$ -potential (see (2.2)) with $k \geq 1$,

$$\|V\|^{(\alpha,k)} \leq d \|V\|^{(\alpha,k+1)}.$$

Proof of Theorem 2.2:

We will repeatedly use the symbol $X_{i,j}$ for the relative accelerations

$$X_{i,j} : \mathbb{R}^{dn} \rightarrow \mathbb{R}^d, \quad X_{i,j}(q) := \sum_{k \in N \setminus \{i\}} \frac{\nabla V_{i,k}(q_i - q_k)}{m_i} - \sum_{k \in N \setminus \{j\}} \frac{\nabla V_{j,k}(q_j - q_k)}{m_j}$$

between the i -th and j -th particle, and the estimate

$$\|X_{i,j}(q)\| \leq 2(n-1) \frac{\|V\|^{(\alpha)}}{q_{\min}^{\alpha+1}} \quad (i < j \in N). \quad (2.7)$$

Throughout the proof we also use that, by Lemma 2.5.2,

$$C \geq 8n \|V\|^{(\alpha)} / \delta. \quad (2.8)$$

1. F_{loc}^+ is open, since it is defined by strict inequalities among continuous functions on phase space. To prove that F_{loc}^+ is forward invariant, it is sufficient to show that the Hamiltonian vector field *points inwards along its boundary* $\partial F_{\text{loc}}^+$. Thus we will show that the difference of the sides of each inequality has positive time derivative at instants at which that inequality becomes an equality.

Note that on $\overline{F_{\text{loc}}^+}$ the phase space functions $q_{i,j}$ and $v_{i,j}$ have positive values and are thus smooth. For q_{\min} , q_{\max} , v_{\min} and v_{\max} , which are only Lipschitz continuous, we consider the distributional derivative.

- (a) On F_{loc}^+ the time derivative relating to the first inequality in (1.8) is positive, since

$$\frac{d}{dt} v_{\min}^2 \geq -2v_{\min} \max_{i < j \in N} \|\dot{v}_i - \dot{v}_j\|,$$

see e.g. LIEB and LOSS [LL, Cor. 6.18] for the weak gradient of the minimum of functions. Thus

$$\begin{aligned} & \frac{d}{dt} \left(v_{\min}^2 - C \frac{q_{\max}}{q_{\min}^{\alpha+1}} \right) \geq \\ & \geq C(\alpha+1) \frac{q_{\max}}{q_{\min}^{\alpha+2}} (1-\delta) v_{\min} - 2v_{\min} \max_{i < j \in N} \|X_{i,j}(q)\| - C \frac{v_{\max}}{q_{\min}^{\alpha+1}} \\ & \geq C \left((\alpha+1)(1-\delta) \frac{v_{\min}}{q_{\min}} - \delta/4 \frac{v_{\min}}{q_{\max}} - \frac{v_{\max}}{q_{\max}} \right) \frac{q_{\max}}{q_{\min}^{\alpha+1}} \\ & \geq C \left((\alpha+1)(1-\delta) - \delta/4 - (1+2\delta) \right) \frac{v_{\min} q_{\max}}{q_{\min}^{\alpha+2}} \\ & = C \left(\alpha(1-\delta) - \frac{13}{4} \delta \right) \frac{v_{\min} q_{\max}}{q_{\min}^{\alpha+2}} > 0. \end{aligned}$$

The factor $1-\delta$ in the first inequality follows from the second line of (1.8). The second inequality follows from (2.7) and (2.8). The factor $1+2\delta$ in the second to last line follows from the third line of (1.8). In the final inequality we used that $\delta \in (0, \min(\alpha/(4+\alpha), 1/5)]$:

- For $\alpha \in (0, 1]$ we obtain $\alpha(1-\delta) - \frac{13}{4} \delta \geq \frac{3\alpha}{4(4+\alpha)} > 0$.

- For $\alpha \in (1, \infty]$ we get $\alpha(1 - \delta) - \frac{13}{4}\delta \geq \frac{4}{5}\alpha - \frac{13}{20} \geq \frac{3}{20}$.

(b) The time derivative of the left hand side of the second inequality

$$\langle v_i - v_j, q_i - q_j \rangle - (1 - \delta)v_{i,j}q_{i,j} > 0$$

in (1.8) is positive, too. This is trivial if $\|V\|^{(\alpha)} = 0$, that is, $V = 0$. Otherwise

$$\begin{aligned} \frac{d}{dt}(\langle v_i - v_j, q_i - q_j \rangle - (1 - \delta)v_{i,j}q_{i,j}) &\geq \\ &\geq v_{i,j}^2 - \langle X_{i,j}(q), q_i - q_j \rangle - (1 - \delta)(v_{i,j}^2 + \|X_{i,j}(q)\|q_{i,j}) \\ &\geq \delta C \frac{q_{\max}^{\alpha+1}}{q_{\min}^{\alpha+1}} - 2(n-1) \frac{\|V\|^{(\alpha)} q_{\max}^{\alpha+1}}{q_{\min}^{\alpha+1}} (2 - \delta) \\ &\geq (8n - 2(n-1)(2 - \delta)) \frac{\|V\|^{(\alpha)} q_{\max}^{\alpha+1}}{q_{\min}^{\alpha+1}} > 4n \frac{\|V\|^{(\alpha)} q_{\max}^{\alpha+1}}{q_{\min}^{\alpha+1}} > 0. \end{aligned}$$

For the third line we used the first inequality of (1.8) and (2.7), and (2.8) for the last line.

(c) Concerning the third inequality in (1.8), as $\frac{dq_{k,l}}{dt} \in [(1 - \delta)v_{k,l}, v_{k,l}]$ (using the second inequality in (1.8)), at value zero of $(1 + 2\delta) \frac{q_{k,l}}{v_{k,l}} - \frac{q_{i,j}}{v_{i,j}}$ its time derivative is estimated as follows:

$$\begin{aligned} \frac{d}{dt} \left((1 + 2\delta) \frac{q_{k,l}}{v_{k,l}} - \frac{q_{i,j}}{v_{i,j}} \right) &\geq \\ &\geq (1 + 2\delta)(1 - \delta) - 1 - ((1 + 2\delta)q_{k,l}\|X_{k,l}(q)\| + q_{i,j}\|X_{i,j}(q)\|)/v_{\min}^2 \\ &\geq \delta - 2\delta^2 - 2(n-1)(1 + \delta) \frac{\|V\|^{(\alpha)} q_{\max}^{\alpha+1}}{v_{\min}^2 q_{\min}^{\alpha+1}} \\ &> \delta(1 - 2\delta) - 4n(1 + \delta) \frac{\|V\|^{(\alpha)}}{C} \geq \delta(1 - 2\delta) - \frac{1}{2}(1 + \delta) \geq \delta(\frac{3}{5} - \frac{6}{10}) = 0. \end{aligned}$$

4. We now prove item 4, before items 2 and 3. Throughout the proof of item 4 we will use that we already proved positive invariance of F_{loc}^+ (item 1). We adopt the notation $\tilde{f}(t) := f \circ \Phi(t, x_0)$ for a phase space function f , with $x_0 \in F_{\text{loc}}^+$.

For $F := \frac{1}{2}\tilde{q}_{i,j}^2$ and $t \geq 0$ we get from (1.8) that

$$F'(t) \geq (1 - \delta)\tilde{q}_{i,j}(t)\tilde{v}_{i,j}(t) \quad (2.9)$$

and

$$F''(t) \geq (1 - \delta) [\tilde{v}_{i,j}^2(t) - \tilde{q}_{i,j}(t)\|\tilde{X}_{i,j}(t)\|] \geq (1 - \delta)(1 - \delta/4)\tilde{v}_{i,j}^2(t) \geq \frac{19}{25}\tilde{v}_{i,j}^2(t). \quad (2.10)$$

The second inequality in (2.10) is valid, since by (2.7), (2.8) and (1.8)

$$\tilde{q}_{i,j}(t) \|\tilde{X}_{i,j}(t)\| \leq \tilde{q}_{i,j}(t) 2(n-1) \frac{\|V\|^{(\alpha)}}{\tilde{q}_{\min}^{\alpha+1}(t)} \leq \frac{1}{4} C \frac{\tilde{q}_{i,j}(t)}{\tilde{q}_{\min}^{\alpha+1}(t)} \delta \leq \frac{\delta}{4} \tilde{v}_{\min}^2(t). \quad (2.11)$$

The third inequality in (2.10) follows from $0 \leq \delta \leq 1/5$.

There exists a maximal $T \in (0, +\infty]$ so that

$$\|(\tilde{v}_i(t) - \tilde{v}_j(t)) - (\tilde{v}_i(0) - \tilde{v}_j(0))\|^2 \leq \frac{1}{6} \tilde{v}_{i,j}^2(0) \quad (t \in [0, T]). \quad (2.12)$$

Thus $(1 - \sqrt{1/6})^2 \tilde{v}_{i,j}^2(0) \leq \tilde{v}_{i,j}^2(t) \leq (1 + \sqrt{1/6})^2 \tilde{v}_{i,j}^2(0)$ within this time interval, and by (2.9), (2.10) this implies

$$\begin{aligned} F(t) &= F(0) + \int_0^t (F'(0) + \int_0^s F''(\tau) d\tau) ds \quad (2.13) \\ &\geq F(0) + (1 - \delta) \tilde{q}_{i,j}(0) \tilde{v}_{i,j}(0) t + \frac{19}{25} \int_0^t \int_0^s \tilde{v}_{i,j}^2(\tau) d\tau ds \\ &\geq \frac{1}{2} \tilde{q}_{i,j}^2(0) + \frac{4}{5} \tilde{q}_{i,j}(0) \tilde{v}_{i,j}(0) t + \frac{19}{50} (1 - \sqrt{1/6})^2 \tilde{v}_{i,j}^2(0) t^2. \end{aligned}$$

Conversely by the first line in (2.13) and (2.11) with $\delta \leq 1/5$,

$$\begin{aligned} F(t) &\leq F(0) + \tilde{q}_{i,j}(0) \tilde{v}_{i,j}(0) t + \frac{21}{20} \int_0^t \int_0^s \tilde{v}_{i,j}^2(\tau) d\tau ds \\ &\leq F(0) + \tilde{q}_{i,j}(0) \tilde{v}_{i,j}(0) t + \frac{21}{40} (1 + \sqrt{1/6})^2 \tilde{v}_{i,j}^2(0) t^2. \end{aligned}$$

These two estimates prove both inequalities in (2.5) for time $t \in [0, T]$.

2. Next we start by showing that $T = +\infty$ in (2.12). With the rescaled time parameter

$$s(t) := \frac{\tilde{v}_{i,j}(0)}{2\tilde{q}_{i,j}(0)} t \quad , \quad \tilde{q}_{i,j}(t) \geq \tilde{q}_{i,j}(0) \langle s(t) \rangle.$$

Note that by definition (1.8) of F_{loc}^+ the scaling factors $\frac{\tilde{v}_{i,j}(0)}{2\tilde{q}_{i,j}(0)}$ are, up to a factor $1 + \delta$, independent of the index pair (i, j) . So by applying (2.12), (2.7), and (1.8) with (2.8) in succession,

$$\begin{aligned} &\|(\tilde{v}_i(t) - \tilde{v}_j(t)) - (\tilde{v}_i(0) - \tilde{v}_j(0))\|^2 = \\ &= -2 \int_0^t \langle \tilde{v}_i(\tau) - \tilde{v}_j(\tau) - (\tilde{v}_i(0) - \tilde{v}_j(0)), \tilde{X}_{i,j}(\tau) \rangle d\tau \\ &\leq \frac{2}{\sqrt{6}} \tilde{v}_{i,j}(0) \int_0^\infty \|\tilde{X}_{i,j}(\tau)\| d\tau \\ &\leq \frac{4}{\sqrt{6}} (n-1) \tilde{v}_{i,j}(0) \|V\|^{(\alpha)} \int_0^\infty \tilde{q}_{\min}(\tau)^{-\alpha-1} d\tau \\ &\leq \frac{8}{\sqrt{6}} (n-1) \tilde{v}_{i,j}(0) \|V\|^{(\alpha)} \frac{(1+\delta)\tilde{q}_{\max}(0)}{\tilde{q}_{\min}^{\alpha+1}(0)\tilde{v}_{i,j}(0)} \int_0^\infty \langle s \rangle^{-\alpha-1} ds \\ &\leq \frac{\sqrt{6}}{5} \tilde{v}_{i,j}^2(0) \delta \int_0^\infty \langle s \rangle^{-\alpha-1} ds \\ &\leq \frac{\sqrt{6}}{5} \tilde{v}_{i,j}^2(0) \min(1/5, \frac{\alpha}{4+\alpha}) \frac{\sqrt{\pi}\Gamma(\alpha/2)}{2\Gamma((1+\alpha)/2)} \\ &\leq \frac{\sqrt{6}\pi}{50} \tilde{v}_{i,j}^2(0) < \tilde{v}_{i,j}(0)^2/6, \end{aligned}$$

since $\min(1/5, \frac{\alpha}{4+\alpha}) \frac{\sqrt{\pi}\Gamma(\alpha/2)}{2\Gamma((1+\alpha)/2)}$ attains its maximal value $\pi/10$ for $\alpha = 1$. This shows that in (2.12) $T = +\infty$. Thus by (2.12) the velocity differences stay bounded away from zero ($\tilde{v}_{i,j}(t) \geq \frac{1}{2}\tilde{v}_{i,j}(0) > 0$ for all $t \geq 0$) so that the initial condition $x_0 \in F_{\text{loc}}^+$ is in F^+ .

3. Let $x_0 \in F^+$. By definition, $v^+(x_0)$ exists and $v^+(x_0) \notin \Delta$. It follows that for any $\delta \in (0, \delta_0]$ there exists a time t_0 such that

$$\|\tilde{v}_k(t) - v_k^+(x_0)\| \leq \frac{1}{8} \delta \bar{v}_{\min}^+(x_0) \quad (k \in N, t \geq t_0). \quad (2.14)$$

In particular

$$\tilde{v}_{\min}(t) \geq (1 - \frac{1}{4}\delta) \bar{v}_{\min}^+(x_0) > 0 \quad (t \geq t_0).$$

As $\|(\tilde{q}_i(t) - \tilde{q}_j(t)) - \int_{t_0}^t (\tilde{v}_i(s) - \tilde{v}_j(s)) ds\| = \tilde{q}_{i,j}(t_0)$,

$$\|(\tilde{q}_i(t) - \tilde{q}_j(t)) - (t - t_0)(\bar{v}_i(x_0) - \bar{v}_j(x_0))\| \leq \delta/4 (t - t_0) \bar{v}_{\min}^+(x_0) + \tilde{q}_{i,j}(t_0). \quad (2.15)$$

So $v_{\min}(x)^2 > C \frac{q_{\max}(x)}{q_{\min}(x)^{\alpha+1}}$ for $x := \Phi(t, x_0)$, $t \geq t_0$ large. This is the first condition in the definition (1.8) of F_{loc}^+ .

Concerning the second condition, similarly by (2.15), for t large

$$\langle \tilde{v}_i(t) - \tilde{v}_j(t), \tilde{q}_i(t) - \tilde{q}_j(t) \rangle \geq (1 - \delta) \tilde{v}_{i,j}(t) \tilde{q}_{i,j}(t)$$

and, for the third condition,

$$(1 + 2\delta) \frac{\tilde{q}_{k,l}(t)}{\tilde{v}_{k,l}(t)} > \frac{\tilde{q}_{i,j}(t)}{\tilde{v}_{i,j}(t)} \quad (i < j, k < l \in N).$$

This shows that $\Phi_t(x_0) \in F_{\text{loc}}^+$ for all t sufficiently large. \square

3 Regularity of the asymptotic velocity

We move on to the regularity of the asymptotic velocity map $v^+ : x \mapsto v^+(x)$.

3.1 Theorem ([DG, Theorem 5.4.1]) *Let the potential $V \in C^2(\mathbb{R}^{dn}, \mathbb{R})$ be long range. Then the asymptotic velocity $v^+(x)$ exists for all $x \in P$.*

The map $v^+ : P \rightarrow \mathbb{R}^{dn}$ is Borel-measurable, but may be discontinuous.

3.2 Example (Discontinuity of the asymptotic velocity)

Take $d = 1$ and $n = 2$ and a non-negative pair potential $V_{1,2} \in C_c^2(\mathbb{R}, \mathbb{R})$ which has compact support, and a non-degenerate unique maximum $V(0) > 0$. Then

the origin is the unique fixed point and is hyperbolic. All trajectories except the hyperbolic fixed point and the four associated separatrix solutions have $|q| \rightarrow \infty$ as $|t| \rightarrow \infty$ and their velocity \dot{q} is locally constant as $|t|$ tends to ∞ . So one sees that v^+ is defined on the whole phase space \mathbb{R}^2 and that its discontinuity locus is the stable manifold of the hyperbolic fixed point. \diamond

We will see that in restriction to the free region F^+ the map v^+ is continuous and even differentiable. We will use the notation

$$p^+(x_0) = \mathcal{M}v^+(x_0) = \lim_{t \rightarrow \infty} p(t).$$

3.3 Theorem

Let V be an (α, k) -potential.

1. The map $v^+ : F^+ \rightarrow \mathbb{R}^{dn}$ is of class C^{k-1} .
2. Quantitatively, if $x_0 = (p_0, q_0) \in F_{\text{loc}}^+$, for multi-indices $\delta := (\beta, \gamma) \in \mathbb{N}_0^{dn} \times \mathbb{N}_0^{dn}$ with $|\delta| \equiv |\beta| + |\gamma| \leq k - 1$ and partial derivatives: $\partial_{x_0}^\delta := \partial_{p_0}^\beta \partial_{q_0}^\gamma$ we get

$$\partial_{x_0}^\delta (p^+(x_0) - p_0) = \mathcal{O} \left(\|V\|^{(\alpha, k)} v_{\min}(x_0)^{-1-|\beta|} \langle q_{\min}(x_0) \rangle^{-\alpha-|\gamma|} \right). \quad (3.1)$$

3.4 Remark (Variants)

The constant in the order estimate (3.1) is independent of V . Using the first condition in the definition (1.8) of F_{loc}^+ , we obtain the weaker estimate

$$\partial_{x_0}^\delta (p^+(x_0) - p_0) = \mathcal{O} \left(v_{\min}(x_0)^{+1-|\beta|} \langle q_{\min}(x_0) \rangle^{-|\gamma|} \right).$$

Similarly, instead of (4.4), we would have the weaker estimate

$$\partial_{X_0}^\delta (Q_0 - q_0) = \mathcal{O} \left(v_{\min}(X_0)^{-|\beta|} \langle q_{\min}(X_0) \rangle^{1-|\gamma|} \right)$$

(where $X_0 = \Omega(x_0) = (Q_0, P_0)$ stands for the image of x_0 by the Møller transformation, as defined in section 4).

These estimates depend on the norm $\|V\|^{(\alpha, k)}$ of the potential only indirectly, via the phase space region F_{loc}^+ where they apply. \diamond

Proof of Theorem 3.3:

We use the shorthands $q_{\min} := q_{\min}(x_0)$, $v_{\min} := v_{\min}(x_0)$ and continue to use the notation $\tilde{f}(t) := f \circ \Phi(t, x_0)$ for a phase space function f .

• To prepare for the proof of Claim 1, we first estimate the initial value problem for long-range potentials. As V is an (α, k) -potential, the flow

$$\Phi \in C^{k-1}(\mathbb{R} \times P, P).$$

For derivatives $\partial_{x_0}^\delta$ w.r.t. initial conditions x_0 with $1 \leq |\delta| \leq k-1$, like in [Kn, section 6] we use the integral representation of the trajectory

$$q(t, x_0) = q_0 + \mathcal{M}^{-1} \left(t p_0 - \int_0^t \int_0^s \nabla V(q(\tau, x_0)) d\tau ds \right) \quad (t \in [0, \infty)).$$

By a standard dominated convergence argument (see, e.g., ELSTRODT [El, Thm. IV.5.7]) its deviation from free motion is controlled by

$$\begin{aligned} \partial_{x_0}^\delta (q(t, x_0) - (q_0 + t\mathcal{M}^{-1}p_0)) &= - \int_0^t \int_0^s \mathcal{M}^{-1} \partial_{x_0}^\delta \nabla V(q(\tau, x_0)) d\tau ds = \quad (3.2) \\ &- \sum_{N=1}^{|\delta|} \mathcal{M}^{-1} \sum_{\substack{\delta^{(1)} + \dots + \delta^{(N)} = \delta \\ |\delta^{(i)}| > 0}} \int_0^t \int_0^s D^N \nabla V(q(\tau, x_0)) \left(\partial_{x_0}^{\delta^{(1)}} q(\tau, x_0), \dots, \partial_{x_0}^{\delta^{(N)}} q(\tau, x_0) \right) d\tau ds. \end{aligned}$$

Due to the $N = 1$ term this is only an implicit equation for $\partial_{x_0}^\delta q(t, x_0)$. To transform it into an explicit equation, we thus consider for $\lambda > 0$ the real Banach space $(\widehat{\mathcal{C}}, \|\cdot\|_\lambda)$,

$$\widehat{\mathcal{C}} := \left\{ w \in C([0, \infty), \mathbb{R}^{dn}) \mid \|w\|_\lambda := \sup_{t \geq 0} \|w(t)\| / \langle \lambda t \rangle < \infty \right\}, \quad (3.3)$$

noting that $\widehat{\mathcal{C}}$ is independent of the choice of λ . Define the linear operator $\mathcal{Q} \equiv \mathcal{Q}_{x_0}$ by

$$\mathcal{Q}(w)(t) := \mathcal{M}^{-1} \int_0^t \int_0^s D \nabla V(q(\tau, x_0)) w(\tau) d\tau ds \quad (t \geq 0), \quad (3.4)$$

Using (2.5) and (2.3), the operator norm is estimated by

$$\begin{aligned} \|\mathcal{Q}\|_\lambda &:= \sup_{w: \|w\|_\lambda = 1} \|\mathcal{Q}(w)\|_\lambda \leq \|V\|^{(\alpha, 2)} \sup_{t \geq 0} \frac{\int_0^t \int_0^s (q_{\min} + \frac{1}{2} v_{\min} \tau)^{-2-\alpha} \langle \lambda \tau \rangle d\tau ds}{\langle \lambda t \rangle} \\ &\leq \frac{\|V\|^{(\alpha, 2)}}{\lambda^2 q_{\min}^{2+\alpha}} \sup_{t \geq 0} \frac{\int_0^t \int_0^s \langle \tau \rangle^{-1-\alpha} d\tau ds}{\langle t \rangle}. \end{aligned}$$

Using Lemma 2.5 in the last inequality and setting

$$\lambda := \frac{1}{2} v_{\min} / q_{\min}$$

yields

$$\|\mathcal{Q}\|_\lambda \leq 4(1 + 1/\alpha) \frac{\|V\|^{(\alpha, 2)}}{v_{\min}^2 q_{\min}^\alpha}.$$

which shows that \mathcal{Q} maps $\widehat{\mathcal{C}}$ into itself. We want to prove that for all $x_0 \in F_{\text{loc}}^+$ the operator norm of \mathcal{Q}_{x_0} is strictly smaller than one for a suitable λ . By Definition (1.8) of F_{loc}^+ the operator is a contraction:

$$\|\mathcal{Q}\|_\lambda \leq \frac{4(1+1/\alpha)}{16\pi dn \max(1, 1/\alpha)} \leq \frac{1}{2\pi dn} < 1.$$

Thus (3.2) can be transformed into

$$\begin{aligned} (\mathbb{1} + \mathcal{Q})(\partial_{x_0}^\delta q)(t) &= \partial_{x_0}^\delta (q_0 + t\mathcal{M}^{-1}p_0) - \mathcal{M}^{-1} \times \\ &\sum_{N=2}^{|\delta|} \sum_{\substack{\delta^{(1)} + \dots + \delta^{(N)} = \delta \\ |\delta^{(i)}| > 0}} \int_0^t \int_0^s D^N \nabla V(q(\tau, x_0)) \left(\partial_{x_0}^{\delta^{(1)}} q(\tau, x_0), \dots, \partial_{x_0}^{\delta^{(N)}} q(\tau, x_0) \right) d\tau ds \end{aligned} \quad (3.5)$$

with the invertible operator $\mathbb{1} + \mathcal{Q}$ on $\widehat{\mathcal{C}}$. As on the r.h.s. of (3.5) only partial derivatives of order $|\delta^{(i)}| < |\delta|$ appear, we can perform an induction in $|\delta|$.

Assume that for all $\delta' = (\beta', \gamma') \in \mathbb{N}_0^{dn} \times \mathbb{N}_0^{dn}$ with $1 \leq |\delta'| \leq |\delta| - 1$

$$\|\partial_{x_0}^{\delta'} q(\cdot, x_0)\|_\lambda = \mathcal{O}(v_{\min}(x_0)^{-|\beta'|} q_{\min}(x_0)^{1-|\gamma'|}). \quad (3.6)$$

This assumption is satisfied for $|\delta'| = 1$, since then the sum on the r.h.s. of (3.5) equals zero. Then by (2.5) and (3.6) the terms on the r.h.s. of (3.5) fulfill

$$\begin{aligned} &\left\| \mathcal{M}^{-1} \int_0^t \int_0^s D^N \nabla V(q(\tau, x_0)) \left(\partial_{x_0}^{\delta^{(1)}} q(\tau, x_0), \dots, \partial_{x_0}^{\delta^{(N)}} q(\tau, x_0) \right) d\tau ds \right\| \leq \\ &\leq \|V\|^{(\alpha, N+1)} \int_0^t \int_0^s q(\tau, x_0)^{-\alpha-N-1} \prod_{i=1}^N \|\partial_{x_0}^{\delta^{(i)}} q(\tau, x_0)\| d\tau ds \\ &\leq \|V\|^{(\alpha, N+1)} \times \\ &\quad \int_0^t \int_0^s \left(q_{\min}(x_0) + \frac{1}{2}v_{\min}(x_0)t \right)^{-\alpha-N-1} \prod_{i=1}^N \left(\|\partial_{x_0}^{\delta^{(i)}} q(\cdot, x_0)\|_\lambda \langle \lambda\tau \rangle \right) d\tau ds \\ &\leq C_0 \|V\|^{(\alpha, N+1)} v_{\min}(x_0)^{-|\beta|} q_{\min}^{-\alpha-|\gamma|-1} \int_0^t \int_0^\infty \langle \lambda\tau \rangle^{-\alpha-1} d\tau ds \\ &\leq C_1 \|V\|^{(\alpha, N+1)} v_{\min}^{-2-|\beta|} q_{\min}^{1-\alpha-|\gamma|} \langle \lambda t \rangle. \end{aligned} \quad (3.7)$$

For $x_0 \in F_{\text{loc}}^+$ that term is bounded above by (see (1.8)) $C_\delta v_{\min}^{-|\beta|} q_{\min}^{1-|\gamma|} \langle \lambda t \rangle$,¹ proving the induction step for (3.6).

¹ δ of C_δ does not refer to the multi-index $\delta \in \mathbb{N}_0^{2dn}$, but to the constant in Theorem 2.2. It is chosen as $\delta := \min(\delta_0, \alpha - 1)$ in the short range case ($\alpha > 1$) and $\delta := \delta_0$ if $0 < \alpha \leq 1$.

- We prove the momentum estimate in (3.1) for no partial derivative w.r.t. initial conditions ($\delta = 0$), which holds for all long range potentials. By the propagation estimate (2.5) uniformly in $t \geq 0$

$$\begin{aligned}
& \|\mathcal{M}^{-1}(\tilde{p}(t) - \tilde{p}(0))\| \\
& \leq \int_0^t \|\mathcal{M}^{-1}\nabla V(\tilde{q}(s))\| ds \leq \|V\|^{(\alpha,1)} \int_0^t (q_{\min} + \frac{1}{2}v_{\min} s)^{-\alpha-1} ds \\
& \leq \frac{\|V\|^{(\alpha,1)}}{\frac{1}{2}v_{\min}} \int_0^\infty (q_{\min} + s)^{-\alpha-1} ds \leq \frac{2\|V\|^{(\alpha,1)}}{\alpha v_{\min} q_{\min}^\alpha}. \tag{3.8}
\end{aligned}$$

Lemma 2.5 was applied in the last step. By the same estimate, which is locally uniform in x_0 ,

$$\bar{v}^+(x_0) = \mathcal{M}^{-1}\bar{p}^+(x_0) = \mathcal{M}^{-1} \lim_{t \rightarrow \infty} \tilde{p}(t)$$

exists and is continuous in $x_0 \in F^+$.

- For multi-index $\delta \in \mathbb{N}_0^{2dn}$ of norm $1 \leq |\delta| \leq k-1$ the momentum estimate

$$\|\mathcal{M}^{-1}\partial_{x_0}^\delta(\tilde{p}(t) - \tilde{p}(0))\| \leq C_2\|V\|^{(\alpha,k)} v_{\min}^{-1-|\beta|} q_{\min}^{-\alpha-|\gamma|} \leq C_\delta v_{\min}^{+1-|\beta|} q_{\min}^{-|\gamma|} \tag{3.9}$$

is derived like the position estimate in and after (3.7). We infer that at $x_0 \in F_{\text{loc}}^+$ asymptotic velocity \bar{v}^+ is $k-1$ times continuously differentiable. This proves item 2.

As the flow $\Phi \in C^{k-1}(\mathbb{R} \times P, P)$ and by Property 3. of Thm. 2.2, the same statement is true for $x_0 \in F^+$. This proves item 1. \square

In [He, Lemma II.2], HERBST noted for $n=2$ that for long range potentials the limit $\lim_{t \rightarrow \infty} (q_2(t, x) - q_1(t, x))$ exists, if the asymptotic velocities coincide. His – perhaps astonishing – result immediately generalizes to the n -body case. To see this, we modify (1.6), setting

$$\widehat{F}^\pm := \{x \in \widehat{P} \mid v^\pm(x) \text{ exists, and } v^\pm(x) \notin \Delta\}. \tag{3.10}$$

3.5 Lemma

For a long range potential V , consider initial conditions $x_0^{(i)} \equiv (p_0^{(i)}, q_0^{(i)}) \in \widehat{F}^\pm$ ($i=1, 2$), whose asymptotic momenta $\bar{p}^\pm(x_0^{(i)})$ coincide. Then

$$a^\pm := \lim_{t \rightarrow \pm\infty} (q(t, x_0^{(2)}) - q(t, x_0^{(1)})) \tag{3.11}$$

exists. More precisely, although the estimate $p(t, x_0) - \bar{p}^\pm(x_0) = \mathcal{O}(|t|^{-\alpha})$ is in general optimal in the $t \rightarrow \pm\infty$ limit,

$$p(t, x_0^{(2)}) - p(t, x_0^{(1)}) = \mathcal{O}(|t|^{-1-\alpha}) \text{ and } q(t, x_0^{(2)}) - q(t, x_0^{(1)}) = a^\pm + \mathcal{O}(|t|^{-\alpha}). \tag{3.12}$$

Finally, if $a^\pm = 0$, then $x_0^{(1)} = x_0^{(2)}$.

Proof:

- To begin with, the estimate $p(t, x_0) - \bar{p}^\pm(x_0) = \mathcal{O}(|t|^{-\alpha})$ follows from (3.8) and the propagation estimate (2.5), and its optimality from

$$\frac{1}{2} \langle \bar{p}^\pm(x_0), \mathcal{M}^{-1} \bar{p}^\pm(x_0) \rangle = \frac{1}{2} \langle p(t, x_0), \mathcal{M}^{-1} p(t, x_0) \rangle + V(q(t, x_0)).$$

- The second estimate in (3.12) and (3.11) follow by integration from the first estimate in (3.12).
- To derive it and the last statement, we argue like in [He, Lemma II.2]. \square

We can also apply Theorem 3.3, which is formulated for non-singular potentials, to the unregularized Hamiltonian flow with an (α, k) -potential $V : \widehat{M} \rightarrow \mathbb{R}$.

The point is, some x 's end in collision, so have no well-defined asymptotic velocity. As in definition 1.6, the phase space regions $\widehat{F}^\pm \subseteq \widehat{P}$ are open. The escape time $T^\pm(x_0)$ for initial conditions x_0 lying in \widehat{F}^\pm are $\pm\infty$ whereas T^- (T^+) are still upper (respectively lower) semicontinuous.

3.6 Corollary (Asymptotic velocities for singular potentials)

1. For $\alpha > 0$ and (α, k) -potentials $V \in C^k(\widehat{M}, \mathbb{R})$, see (2.3), the restricted asymptotic velocity maps \bar{v}^\pm are C^{k-1} over \widehat{F}^\pm .
2. So for $(-\alpha)$ -homogeneous potentials, that is

$$V(q) := \sum_{1 \leq i < j \leq n} \frac{I_{i,j}}{\|q_i - q_j\|^\alpha}. \quad (3.13)$$

the asymptotic velocities \bar{v}^\pm are smooth on \widehat{F}^\pm .

Proof:

1. The flow is C^{k-1} on its domain and if $x_0 \in F^+$ then there is a time $t \geq 0$ so that $\Phi_t(x_0) \in F_{\text{loc}}^+$. (The norm $\|V\|^{(\alpha, 2)}$ appearing in Thm. 2.2 needs to be appropriately re-defined to account for blow-up along Δ). Then by Theorem 3.3.1 the restriction of the asymptotic velocity v^+ to F^+ is a C^{k-1} with values in \mathbb{R}^{dn} .
2. V in (3.13) has finite $\|V\|^{(\alpha, k)}$ norm for any $k \in \mathbb{N}$. \square

4 The Møller conjugacy (short range)

We will now show that for a short range potential the flow and the free flow are conjugate, using the so-called Møller transformation.

If the potential is short range ($\alpha > 1$ in (1.6)), then we can establish the asymptotics

$$q(t) = at + b + \mathcal{O}(t^{1-\alpha}) \quad \text{as } t \rightarrow +\infty$$

for forward free solutions, see equation (4.4) below. The vector a is $v^+(x_0)$ if $x_0 := (\mathcal{M}\dot{q}(0), q(0))$ is the initial condition for $q(t)$. The vector b is something like the ‘‘impact parameter’’ found in standard treatments of classical scattering. We would like to think of $a, b \in \mathbb{R}^{dn}$ as initial conditions at $t = +\infty$.

One way to formalize this idea is via the Møller transformation, which compares the given flow to that of a free particle.

4.1 Definition The (forward) Møller transformation, where the (pointwise) limit exists, is the map $\Omega = \Omega_+ := \lim_{t \rightarrow +\infty} \Phi_{-t} \circ \Phi_t^0 : P \rightarrow P$. Similarly the backward Møller transformation is $\Omega_- := \lim_{t \rightarrow -\infty} \Phi_{-t} \circ \Phi_t^0$, where the limit exists.

See figure 4.1 for a depiction of the forward and backward Møller transformations. We have continued to use the broken arrow notation in the definition of the Møller transformation to allow ourselves vagueness about its domain. We repair this vagueness now. Moreover, these transformations provide us with conjugacy in the short range case.

4.2 Theorem (Møller transformation)

If the (α, k) -potential V is short range ($\alpha > 1$ in definition 2.1), then

1. For F_0^+ and F^+ defined in (1.10) respectively in (2.4), the Møller transformation

$$\Omega = \lim_{t \rightarrow +\infty} \Phi_{-t} \circ \Phi_t^0 : F_0^+ \rightarrow F^+ \quad (4.1)$$

exists and is a C^{k-1} symplectomorphism intertwining Φ_t with $\Phi_t^{(0)}$:

$$\Omega \circ \Phi_t^{(0)} = \Phi_t \circ \Omega \quad (t \in \mathbb{R}). \quad (4.2)$$

2. If $|\delta| \leq k - 1$, $x_0 = (p_0, q_0) \in F_{\text{loc}}^+$ and $\Omega(x_0) = X_0 = (P_0, Q_0)$ then the inverse Møller transformation Ω^{-1} satisfies the regularity estimates:

$$\partial_{X_0}^\delta (P_0 - p_0) = \mathcal{O} \left(\|V\|^{(\alpha, k)} v_{\min}(X_0)^{-1-|\beta|} \langle q_{\min}(X_0) \rangle^{-\alpha-|\gamma|} \right), \quad (4.3)$$

$$\partial_{X_0}^\delta (Q_0 - q_0) = \mathcal{O} \left(\|V\|^{(\alpha, k)} v_{\min}(X_0)^{-2-|\beta|} \langle q_{\min}(X_0) \rangle^{1-\alpha-|\gamma|} \right). \quad (4.4)$$

We will deal with long range (α, k) -potentials with $\alpha \in (1/2, 1]$ later; we will show existence of modified ‘Dollard’ Møller transformations in Theorem 5.3, indicating how to generalize this to $\alpha \in (0, 1]$.

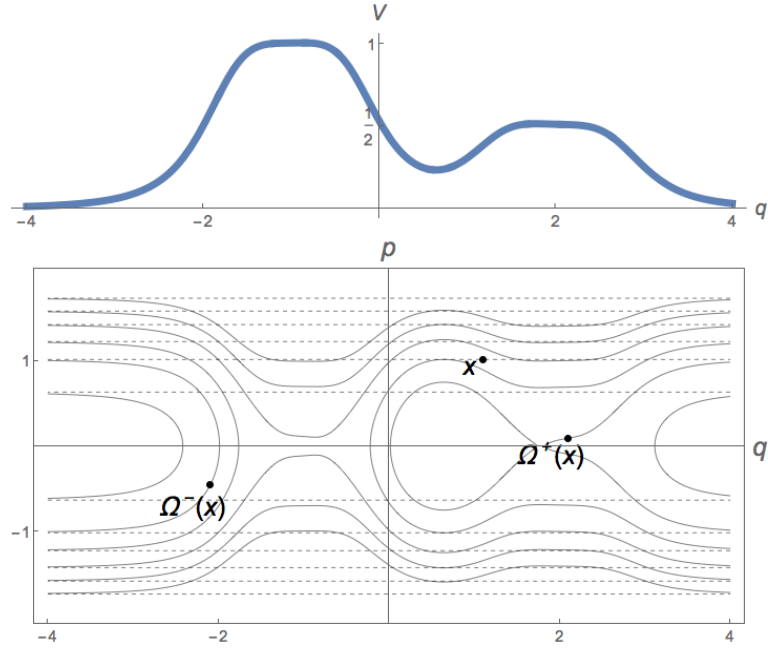

Figure 4.1: Above: Potential V . Below: Level lines of the Hamiltonian H and of the kinetic energy T (dashed); and the corresponding Møller transformations.

Let us pause to see how Theorems 2.2 and 4.2 are related. Suppose that $\Omega(A, B) = x_0 \in F^+$. We claim that $A = \mathcal{M}v^+(x_0)$ where $v^+(x_0) \notin \Delta$ is x_0 's asymptotic velocity of definition 1.5 and described in Theorem 1.10. Inverting, we have $\Omega^{-1}(x_0) = (A, B)$ and $\Omega^{-1} = \lim_{t \rightarrow \infty} \Phi_{-t}^0 \circ \Phi_t$. Write $\Phi_t(x_0) = (p(t, x_0), q(t, x_0))$ and set $p(\infty) = \mathcal{M}v^+(x_0) = A$. Theorem 1.10 tells us that for t large we have $p(t, x_0) = A + o(1)$. Now the momentum p is constant under the free flow so that for large t we have $\Phi_{-t}^0 \circ \Phi_t(x_0) = (A + o(1), Q(x_0; t))$. Letting $t \rightarrow \infty$ kills the $o(1)$ term and yields the claim: $\Omega^{-1}(x_0) = (A, *)$.

Proof of Theorem 4.2:

- We now prove for (α, k) -potentials V of short range ($\alpha > 1$) pointwise existence and smoothness properties of the Møller transformation. Thus let $X_0 = (P_0, Q_0) \in F_0$ and write $\tilde{Q}(t) := Q_0 + \mathcal{M}^{-1}P_0 t$ for the corresponding free solution. (See (1.9).) Define the map $\mathcal{F}_{X_0, T} \equiv$

$$\mathcal{F} : \widehat{\mathcal{D}} \rightarrow C([T, \infty), \mathbb{R}^{dn}) \quad , \quad (\mathcal{F}r)(t) = -\mathcal{M}^{-1} \int_t^\infty \int_s^\infty \nabla V((\tilde{Q} + r)(\tau)) d\tau ds \quad (4.5)$$

on the complete metric space

$$\widehat{\mathcal{D}} \equiv \widehat{\mathcal{D}}_{X_0, T} := \left\{ r \in C([T, \infty), \mathbb{R}^{dn}) \mid \|r\| := \sup_{t \geq T} \|r(t)\| \leq \frac{1}{2} q_{\min}(X_0) \right\}. \quad (4.6)$$

By the short range assumption on V the map \mathcal{F} is well-defined, and any function $u = \mathcal{F}(r)$ in its image satisfies $\lim_{t \rightarrow \infty} u(t) = 0$.

We search for solutions r of the fixed point problem $r = \mathcal{F}_{X_0}(r)$. Out of such a fixed point r we will build $\Omega(X_0)$. First, observe that if r is such a fixed point then

$$q := \tilde{Q} + r \quad (4.7)$$

satisfies Newton's equations $\ddot{q}(t) = -\mathcal{M}^{-1} \nabla V(q(t))$ and is asymptotic to \tilde{Q} . When $X_0 \in F_{\text{loc}}^+ \subseteq F_0$, then by (2.5) and (4.6) the interparticle distances $\tilde{q}_{i,j}(\tau) \geq \frac{1}{2}(q_{i,j} + v_{i,j}\tau)$. Thus, using (2.3)

$$\|\mathcal{M}^{-1} \nabla V((\tilde{Q} + r)(\tau))\| \leq \|V\|^{(\alpha)} \left\langle \frac{1}{2}(q_{\min} + v_{\min}\tau) \right\rangle^{-1-\alpha} \quad (\tau \geq 0).$$

So by Lemma 2.5 $\|\mathcal{M}^{-1} \int_s^\infty \nabla V((\tilde{Q} + r)(\tau)) d\tau\| \leq \frac{2\|V\|^{(\alpha)}}{v_{\min}} \left\langle \frac{1}{2}(q_{\min} + v_{\min}s) \right\rangle^{-\alpha}$ and $\|(\mathcal{F}r)(t)\| \leq \frac{2\|V\|^{(\alpha)}}{(\alpha-1)v_{\min}^2} \left\langle \frac{1}{2}q_{\min} \right\rangle^{1-\alpha} \leq \frac{8d\|V\|^{(\alpha,1)}}{(\alpha-1)v_{\min}^2} \left(\frac{1}{2}q_{\min}\right)^{1-\alpha} \leq \frac{1}{2}q_{\min}$,

as $X_0 \in F_{\text{loc}}^+$ and $\delta \leq \alpha - 1$. So \mathcal{F} maps $\widehat{\mathcal{D}}$ into itself.

Next we show that \mathcal{F} is a contraction on $\widehat{\mathcal{D}}$. So let $r^{(0)} \neq r^{(1)} \in \widehat{\mathcal{D}}$. Then

$$\frac{\|\mathcal{F}(r^{(0)}) - \mathcal{F}(r^{(1)})\|}{\|r^{(0)} - r^{(1)}\|} \leq \int_0^\infty \int_s^\infty \int_0^1 \|\mathcal{M}^{-1} D \nabla V((\tilde{Q} + r^{(\rho)})(\tau))\| d\rho d\tau ds$$

with $r^{(\rho)} := (1 - \rho)r^{(0)} + \rho r^{(1)}$. The right hand side is majorized by

$$\|V\|^{(\alpha,2)} \int_t^\infty \int_s^\infty \left\langle \frac{1}{2}(q_{\min} + v_{i,j}s) \right\rangle^{-2-\alpha} d\tau ds \leq \frac{2\|V\|^{(\alpha,2)}}{\alpha(1+\alpha)v_{i,j}^2 q_{\min}^\alpha} \leq \frac{\delta}{16dn} < 1.$$

By Banach's theorem \mathcal{F}_{X_0} has a unique fixed point r . Evaluating the corresponding solution $\tilde{Q}(t) + r(t)$ to Newton's equations appropriately at $t = 0$ yields the value of the Møller transformation on X_0 . Indeed we claim that

$$\Omega(X_0) = (P_0 + \mathcal{M}\dot{r}(0), Q_0 + r(0)).$$

To see this, we approach the problem of approximating $r(t)$ "from the other end of time" as follows. Write

$$\Phi_{-T} \circ \Phi_T^{(0)}(X_0) = (P_0 + \mathcal{M}(\dot{r}^{(T)})(0), Q_0 + r^{(T)}(0)).$$

Then the solution $r^{(T)} : [0, T] \rightarrow \mathbb{R}^{dn}$ to Newton's equations with initial position $r^{(T)}(0)$ and initial velocity $\dot{r}^{(T)}(0)$ is the unique fixed point of the map

$$\mathcal{F}^{(T)} : \widehat{\mathcal{D}}^{(T)} \rightarrow \widehat{\mathcal{D}}^{(T)}, \quad (\mathcal{F}^{(T)} r^{(T)})(t) = -\mathcal{M}^{-1} \int_t^T \int_s^T \nabla V((\tilde{Q} + r)(\tau^{(T)})) d\tau ds$$

on

$$\widehat{\mathcal{D}}^{(T)} := \{r \in C([0, T], \mathbb{R}^{dn}) \mid \max_{t \in [0, T]} \|r(t)\| \leq \frac{1}{2} q_{\min}(X_0), r(T) = \dot{r}(T) = 0\},$$

and by uniqueness of the original fixed point r we must have that

$$r(t) = \lim_{T \rightarrow +\infty} r^{(T)}(t), \quad \dot{r}(t) = \lim_{T \rightarrow +\infty} \dot{r}^{(T)}(t) \quad (t \geq 0).$$

To see that Møller transformation is defined on all of F_0 , observe that for any $X_0 \in F^+$ we have, eventually, for large enough times h that $\Phi_h^{(0)}(X_0) \in F_{\text{loc}}$, at which point we have just seen that $\Omega(\Phi_h^{(0)}(X_0))$ exists. Then observe by inspecting the definition of the limits that $\Omega(X_0) = \Phi_{-h} \circ \Omega \circ \Phi_h^{(0)}(X_0)$.

As a locally uniform limit the Møller transformation is continuous on F^+ . The intertwining relation (4.2) follows, since the flows are \mathbb{R} -actions, or alternatively by re-arranging the just-proved relationship, $\Omega = \Phi_{-h} \circ \Omega \circ \Phi_h^{(0)}$ valid for all sufficiently large h in a neighborhood of any X_0 .

• To investigate the degree of smoothness of Ω^+ , instead of the operator (3.4) related to the initial value problem, we now use the operator $\mathcal{P} \equiv \mathcal{P}_{X_0}$, with

$$\mathcal{P}(w)(t) := -\mathcal{M}^{-1} \int_t^\infty \int_s^\infty D\nabla V(\tilde{Q}(\tau)) w(\tau) d\tau ds \quad (t \geq 0), \quad (4.8)$$

on the Banach space $C^b([0, \infty), \mathbb{R}^{dn})$ of bounded curves. Its operator norm is majorized by

$$\begin{aligned} \|\mathcal{P}_{X_0}\| &\leq \|V\|^{(\alpha, 2)} \int_0^\infty \int_s^\infty \langle \tilde{Q}(\tau) \rangle^{-2-\alpha} d\tau ds \\ &\leq \|V\|^{(\alpha, 2)} \int_0^\infty \int_s^\infty \left\langle \frac{1}{2}(q_{\min} + v_{\min} s) \right\rangle^{-2-\alpha} d\tau ds \\ &\leq \frac{2^{2+\alpha}}{\alpha} \|V\|^{(\alpha, 2)} q_{\min}^{-\alpha} v_{\min}^{-2} \leq \frac{2^{2+\alpha}}{\alpha} \frac{\delta}{16dn} < 1 \end{aligned}$$

if $\alpha \leq 3$ (for larger α one uses the forward flow into F_{loc}^+ , where the estimates become better). So we can invert $\text{Id} - \mathcal{P}_{X_0}$ in order to solve for $|\delta| \leq k - 1$

$$\begin{aligned} \partial_{X_0}^\delta r(t, X_0) &= - \int_t^\infty \int_s^\infty \mathcal{M}^{-1} \partial_{X_0}^\delta \nabla V(q(\tau, X_0)) d\tau ds = - \sum_{N=1}^{|\delta|} \mathcal{M}^{-1} \times \\ &\times \sum_{\substack{\delta^{(1)} + \dots + \delta^{(N)} = \delta \\ |\delta^{(i)}| > 0}} \int_t^\infty \int_s^\infty D^N \nabla V(q(\tau, X_0)) \left(\partial_{X_0}^{\delta^{(1)}} q(\tau, X_0), \dots, \partial_{X_0}^{\delta^{(N)}} q(\tau, X_0) \right) d\tau ds \end{aligned} \quad (4.9)$$

with the shorthand $q = \tilde{Q} + r$ in a way similar to (3.5). This shows (4.4) and finishes the proof of Claim 2.

As C^1 -limit of the symplectomorphisms $\Phi_{-t} \circ \Phi_t^{(0)}$ the Møller transformation Ω^+ is a symplectomorphism onto its image. But this image coincides with F^+ , by its mere definition (2.4) and by reversing the roles of the two flows.

So Claim 1 is also true. \square

4.3 Remark (Møller transform)

The standard reference for the *Møller* transform is section 5 of [DG] by DEREZIŃSKI and GÉRARD. In the case of finite-range interactions HUNZIKER, in [Hu1, Hu2] proved that the Møller transform exists and used it to establish *asymptotic completeness* of finite range interactions. This asymptotic completeness includes the decomposition of solutions into independent clusters where ‘cluster’ has the meaning alluded to above.

Hunziker viewed the Møller transform as the classical version of the quantum Møller transform, or wave map, defined as the limit of $\exp(-itH) \exp(itH_0)$ as $t \rightarrow \infty$. Here $H = H_0 + V$ is the quantum version of our Hamiltonian so that H_0 corresponds to a multiple of the Laplacian on \mathbb{R}^{dn} .

Soon afterwards, SIMON [Sim] used the method to establish asymptotic completeness for the classical two-body problem with short range interactions provided the second derivative of the potential decays appropriately. In an appendix Simon exhibited the necessity of his second derivative decay conditions by constructing a potential for which his decay conditions failed and which admits two distinct hyperbolic solutions asymptotic to the same free solution. Thus $\Omega^{-1}(x_0) = \Omega^{-1}(y_0)$ for x_0, y_0 not lying on the same orbit, so that whatever Ω is, it is at least “two-valued” and not a well-defined map.

DEREZIŃSKI and GÉRARD, among many other results, established the existence and invertibility of the Møller transformation for potentials of superexponential decrease in [DG, sect. 5.10]. \diamond

5 The Dollard-Møller conjugacy (long range)

The gravitational and Coulomb potentials are long range but not short range so the Møller transformation fails to exist for them. Dollard [Do] discovered that by modifying the comparison free dynamics in a time-dependent way he could define a modified Møller transformation which existed for long range potentials. We will call his modified transformation the Dollard-Møller transformation. It

will yield the asymptotics

$$\begin{aligned} p(t) &= \mathcal{M}v + o(1) \\ q(t) &= vt + W(t, \mathcal{M}v) + b + o(1) \end{aligned}$$

with $v = v^+(x(0))$ and $W(t, \mathcal{M}v) = o(t)$ as $t \rightarrow +\infty$

valid for all escape solutions $x(t) = (p(t), q(t))$ and all long-range potentials ($0 < \alpha \leq 1$ in (1.6)), whether they have singularities or not. See equation (5.3) for the relation between W and the potential V . This assertion on asymptotics follows from the existence of the inverse Dollard-Møller transformation Ω^{-1} , part 1 of 5.3. See remark 5.5 for a sketch of a proof of a derivation of (5.1) from part 1. The asymptotic velocity v occurring in the asymptotics (5.1) is given by $\Omega^{-1}(x(0)) = (v, \beta)$ for some β . The “impact parameter” b , projected onto v^\perp represents the affine orbital parameter described in part 3 of 5.3 below.

5.1 Definition

The Dollard dynamics $\Phi_{t,s}^D$ (see (5.9)) associated with a potential V on \mathbb{R}^{dn} is the non-autonomous flow defined by the time dependent *Dollard Hamiltonian*

$$H^D := K + \tilde{H}^D : \mathbb{R}_t \times F_0 \longrightarrow \mathbb{R}$$

given by

$$H^D(t, p, q) = \frac{1}{2}\langle p, \mathcal{M}^{-1}p \rangle + V(\langle t \rangle \mathcal{M}^{-1}p) \text{ where } \langle t \rangle = \sqrt{1+t^2} \quad (5.1)$$

The first term K of H^D is the usual kinetic energy. Its second term $\tilde{H}_t^D(p, q)$ is the potential turned into a function of momentum. H^D is independent of q so the momentum p is constant along the non-autonomous Dollard flow $\Phi_{t,s}^D$.

5.2 Example (Newtonian case)

Take the case of the Newtonian n -body problem, where the potential is homogeneous of degree -1 . Using $\langle t \rangle = t(1 + \frac{1}{2t^2} + \dots)$ for $t \gg 1$ we see that $H_D = \frac{1}{2}\langle p, \mathcal{M}^{-1}p \rangle + V(\langle t \rangle \mathcal{M}^{-1}p) = \frac{1}{2}\langle p, \mathcal{M}^{-1}p \rangle + \frac{1}{t}V(\mathcal{M}^{-1}p) + \mathcal{O}(1/t^3)$ for large t , where the $\mathcal{O}(1/t^3)$ term depends only on p . Then the ODEs to solve to find the Dollard flow are

$$\begin{cases} \dot{q} = \mathcal{M}^{-1}p + \frac{1}{t}\nabla V(\mathcal{M}^{-1}p) + \mathcal{O}(1/t^3) \\ \dot{p} = 0 \end{cases}$$

which integrate to yield precisely Chazy’s asymptotics (1.11) above. Compare with CHAZY [Cha, page 46], 1922. One could argue that the proper Dollard Hamiltonian (B.1) has Chazy’s work as a precursor. \diamond

Returning to a general V , we compute the time-dependent flow of H^D , for initial time $s \in \mathbb{R}$ and final time $t \in \mathbb{R}$, to have the form:

$$\Phi_{t,s}^D(p, q) = (p, q + (tv + W(t; p)) - (sv + W(s; p))) \quad ((p, q) \in F_0). \quad (5.2)$$

where

$$W : \mathbb{R}_t \times F_0 \rightarrow \mathbb{R}^{dn} \quad , \quad W(t; p) = \int_0^t \nabla_p V(\langle s \rangle \mathcal{M}^{-1} p) ds. \quad (5.3)$$

If V is an (α, k) potential then $W \in C^{k-1}(\mathbb{R}_t \times F_0, \mathbb{R}^{dn})$, and

$$t \mapsto W(t; p) = \begin{cases} \mathcal{O}(|t|^{1-\alpha}) & , \alpha \in (1/2, 1) \\ \mathcal{O}(\log(|t|)) & , \alpha = 1, \end{cases} \quad (|t| \rightarrow \infty).$$

Although the correction term $W(t, p)$ to linear motion can go to infinity with t , we have that $W(t, p) = o(t)$, which is to say, that $|t| \gg |W(t; p)|$ as $t \rightarrow \infty$. It will be crucial below that for fixed p and t_0 ,

$$W(t + t_0, p) - W(t, p) \rightarrow 0 \text{ as } t \rightarrow \infty, \quad (5.4)$$

as the reader can easily verify.

The asymptotic velocity of any Dollard solution curve $\Phi_{t,s}^D(x_0)$ with $x_0 = (p, q)$ is $v = \mathcal{M}^{-1}p$. All Dollard solutions (5.2) which share a fixed initial momentum p are translates of one another:

$$\Phi_{t,s}^D(p, q^{(2)}) - \Phi_{t,s}^D(p, q^{(1)}) = (0, q^{(2)} - q^{(1)}) \quad (s, t \in \mathbb{R}, q^{(i)} \in \mathbb{R}^{dn}).$$

For explicit computations of Dollard flows and comparison of the induced transformations with Møller transformations see the appendices.

We will use the Dollard flow $\Phi_{0,t}^D$ in place of the free flow $\Phi_t^{(0)}$ in order to define a version of the Møller transformation. However, collisions in backward time prevent us from defining a direct Dollard-Møller transform on \widehat{F}^+ . The backward n -body flow $\widehat{\Phi}_{-t}$, $t > 0$, applied to some points of \widehat{F}^+ may not exist due to multi-body collisions in backwards time. To circumvent this problem we instead define the *inverse* Dollard-Møller transformation, whose definition only uses the forward flow, so that its domain can be taken to be \widehat{F}^+ .

(The reader may wish to refer to subsection 1.5 for notations.)

5.3 Theorem (Dollard-Møller transformations)

For long range (α, k) -potentials V (see (2.3)) with $\alpha \in (1/2, 1]$ and collision singularities allowed, the following hold.

1. The backward and forward inverse Dollard-Møller transformations

$$\Omega^{-1, \pm} := \lim_{T \rightarrow \pm\infty} \Phi_{0,T}^D \circ \widehat{\Phi}_T \quad , \quad \Omega^{-1, \pm} : \widehat{F}^{\pm} \rightarrow F_0 \quad (5.5)$$

exist in the sense of locally uniform convergence.

2. a) These transformations conjugate the n -body flow on \widehat{F}^\pm with the free flow

$$\Omega^{-1,\pm} \circ \widehat{\Phi}_t = \Phi_t^{(0)} \circ \Omega^{-1,\pm}. \quad (5.6)$$

b) For $k \geq 3$ the $\Omega^{-1,\pm}$ are C^{k-2} -smooth symplectomorphisms onto their images.

3. The analog of (5.7) holds for $\Omega^{-1,\pm} - Id$:

If $|\delta| \leq k - 1$, $x_0 = (p_0, q_0) \in F_{\text{loc}}^\pm$ and $\Omega^{-1,\pm}(x_0) = X_0 = (P_0, Q_0)$ then the following regularity estimates hold:

$$\partial_{X_0}^\delta (P_0 - p_0) = \mathcal{O}\left(\|V\|^{(\alpha,k)} v_{\min}(X_0)^{-1-|\beta|} \langle q_{\min}(X_0) \rangle^{-\alpha-|\gamma|}\right), \quad (5.7)$$

$$\partial_{X_0}^\delta (Q_0 - q_0) = \mathcal{O}\left(\|V\|^{(\alpha,k)} v_{\min}(X_0)^{-2-|\beta|} \langle q_{\min}(X_0) \rangle^{1-\alpha-|\gamma|}\right). \quad (5.8)$$

4. For any $v \in \mathbb{R}^{dn} \setminus \Delta$, the space of orbits having asymptotic velocity v form an affine space with underlying vector space the tangent space of the sphere S^{dn-1} at $v/\|v\|_{\mathcal{M}}$.

Proof:

We will make use of the open subset F_{loc}^+ of \widehat{P} defined by precisely the same conditions as F_{loc}^+ in (1.8) with all points lying in \widehat{P} - the phase space points with no collisions. Note that for α -homogeneous potentials, the conditions within (1.8) respect the homogeneity of kinetic and potential energy.

• As both flows $\widehat{\Phi}$ and $\Phi_{\bullet,\bullet}^D$ are C^{k-1} -smooth on their maximal domains (\widehat{D} for $\widehat{\Phi}$ and $\mathbb{R}_t \times \mathbb{R}_s \times F_0$ for $\Phi_{\bullet,\bullet}^D$), by Theorem 2.2.3 and its Corollary 3.6 we can assume without loss of generality that $x_0 = (p_0, q_0) \in \widehat{F}_{\text{loc}}^+$.

We consider the Dollard solution (5.2), $t \mapsto \Phi_{t,0}^D(X)$ with initial value $X \in F_0$ and denote by $X_T(x_0)$ the initial value with the property

$$\Phi_{T,0}^D(X_T(x_0)) = \widehat{\Phi}_T(x_0) \quad (x_0 \in \widehat{F}_{\text{loc}}^+, T \geq 0).$$

Since $\Phi_{\bullet,\bullet}^D$ is the solution of a time dependent initial value problem, we have

$$\Phi_{t,t}^D = \text{Id}_{F_0} \quad \text{and} \quad \Phi_{t_2,t_1}^D \circ \Phi_{t_1,t_0}^D = \Phi_{t_2,t_0}^D \quad (t, t_i \in \mathbb{R}), \quad (5.9)$$

so that $(\Phi_{t_1,t_0}^D)^{-1} = \Phi_{t_0,t_1}^D$.

Proof of part 1 of the theorem.

In (5.5) we claim pointwise existence and local uniformity of the limit $T \rightarrow \infty$ of

$$\Omega_T^{-1} := (\Phi_{T,0}^D)^{-1} \circ \widehat{\Phi}_T = \Phi_{0,T}^D \circ \widehat{\Phi}_T. \quad (5.10)$$

We compute, with $v := \mathcal{M}^{-1}p$ denoting velocity, that

$$\begin{aligned}\Omega_T^{-1}(x_0) &= \left(p(T, x_0), q(T, x_0) - v(T, x_0)T - \int_0^T \nabla_p V(\langle s \rangle \mathcal{M}^{-1}p(T, x_0)) ds \right) \\ &= \left(p(T, x_0), q_0 + r(T, x_0) \right),\end{aligned}\quad (5.11)$$

where

$$\begin{aligned}r(T, x_0) &:= \int_0^T \left[v(s, x_0) - v(T, x_0) - \nabla_p V(\langle s \rangle \mathcal{M}^{-1}p(T, x_0)) \right] ds \\ &= \mathcal{M}^{-1} \int_0^T \left[\int_s^T \nabla V(q(\tau, x_0)) d\tau - \langle s \rangle \nabla V(\langle s \rangle \mathcal{M}^{-1}p(T, x_0)) \right] ds,\end{aligned}\quad (5.12)$$

see (5.2) and (5.3).

• We begin the proof of (5.5) by showing that

$$r^+(x_0) := \lim_{T \rightarrow +\infty} r(T, x_0) = r(0, x_0) + \lim_{T \rightarrow +\infty} \int_0^T \dot{r}(t, x_0) dt$$

exists. Therefore, we first estimate its T -derivative.

$$\begin{aligned}\dot{r}(T, x_0) &= -T \dot{v}(T, x_0) - \langle T \rangle \nabla V(\langle T \rangle \mathcal{M}^{-1}p(T, x_0)) \\ &\quad + \mathcal{M}^{-1} \int_0^T \langle s \rangle^2 D \nabla V(\langle s \rangle \mathcal{M}^{-1}p(T, x_0)) ds \mathcal{M}^{-1} \nabla V(q(T, x_0)).\end{aligned}\quad (5.13)$$

The propagation estimate (2.5) and (3.8) imply that $\|p(T, x_0) - p^+(x_0)\| = \mathcal{O}(\langle T \rangle^{-\alpha})$ and thus locally uniformly in $x_0 \in \widehat{F}_{\text{loc}}^+$

$$\|q(T, x_0) - (q_0 + v^+(x_0)T)\| = \begin{cases} \mathcal{O}(\langle T \rangle^{1-\alpha}) & , \alpha < 1 \\ \mathcal{O}(\log(T)) & , \alpha = 1 \end{cases}.$$

1. For $\alpha \in (1/2, 1)$ the first line on the right hand side of (5.13) equals

$$\begin{aligned}& \mathcal{M}^{-1} \left[T \nabla V(q(T, x_0)) - \langle T \rangle \nabla V(\langle T \rangle \mathcal{M}^{-1}p(T, x_0)) \right] \\ &= T \mathcal{M}^{-1} \left[\nabla V(q(T, x_0)) - \nabla V(\langle T \rangle v(T, x_0)) \right] + \mathcal{O}(\langle T \rangle^{-2-\alpha}) \\ &= T \mathcal{M}^{-1} \left[\nabla V(\langle T \rangle v(T, x_0) + \mathcal{O}(T^{1-\alpha})) - \nabla V(\langle T \rangle v(T, x_0)) \right] + \mathcal{O}(\langle T \rangle^{-2-\alpha}) \\ &= \mathcal{O}(\langle T \rangle^{-2\alpha}) + \mathcal{O}(\langle T \rangle^{-2-\alpha}) = \mathcal{O}(\langle T \rangle^{-2\alpha}),\end{aligned}$$

since $\langle T \rangle - T = \mathcal{O}(\langle T \rangle^{-1})$.

2. As $D \nabla V(\langle s \rangle \mathcal{M}^{-1}p(T, x_0)) = \mathcal{O}(\langle s \rangle^{-2-\alpha})$, for $\alpha \in (1/2, 1)$ the second line of (5.13) has the order $\mathcal{O}(\langle T \rangle^{1-\alpha} \langle T \rangle^{-1-\alpha}) = \mathcal{O}(\langle T \rangle^{-2\alpha})$, too.

3. For $\alpha = 1$ the orders of both lines in (5.13) are $\mathcal{O}(\langle T \rangle^{-2} \log(\langle T \rangle))$.

We conclude that (5.13) is of order $\mathcal{O}(T^{-2\alpha})$ for $\alpha \in (1/2, 1)$, respectively $\mathcal{O}(T^{-2} \log(T))$ for $\alpha = 1$. By our assumption $2\alpha > 1$ we finally obtain existence of $r^+(x_0)$, and thus of inverse Dollard-Møller transformation $\Omega^{-1} = \lim_{T \rightarrow +\infty} \Omega_T^{-1}$.

- As $r^+(x_0) = \lim_{T \rightarrow +\infty} r(T, x_0)$ exists, by the analogs of (5.12) and (5.13)

$$r_i(T, x_0) = r_i^+(x_0) - \int_T^\infty \dot{r}_i(\tau, x_0) d\tau = r_i^+(x_0) + \frac{1}{m_i} \sum_{j \in N \setminus \{i\}} \quad (5.14)$$

$$\left[\int_T^\infty \left(\tau \nabla V_{i,j}(q_i(\tau, x_0) - q_j(\tau, x_0)) - \langle \tau \rangle \nabla V_{i,j}(\langle \tau \rangle (v_i(\tau, x_0) - v_j(\tau, x_0))) \right) d\tau \right. \\ \left. - \int_T^\infty \int_\tau^\infty \langle s \rangle^2 D \nabla V_{i,j}(\langle s \rangle (v_i(\tau, x_0) - v_j(\tau, x_0))) (\dot{v}_i(\tau, x_0) - \dot{v}_j(\tau, x_0)) ds d\tau \right].$$

When one substitutes the argument $q_i(\tau, x_0) - q_j(\tau, x_0)$ in the second line of (5.14), using $q(\tau, x_0) = v(\tau, x_0)\tau + W(\tau; \Phi_\tau(x_0)) - r(\tau, x_0)$, then one obtains an integral equation for r .

When we assume that r belongs to the complete metric space $\widehat{\mathcal{D}}_{X_0, T}$ defined in (4.6), then the integrand is of order $\mathcal{O}(\tau^{-2\alpha})$ for $\alpha \in (1/2, 1)$ and $\mathcal{O}(\tau^{-2} \log(\tau))$ for $\alpha = 1$. So from (5.14) we infer that $r(T, x_0) - r^+(x_0)$ is of order $\mathcal{O}(T^{1-2\alpha})$, resp. $\mathcal{O}(T^{-1} \log(T))$. As a function of r , the right hand side of (5.14) is a contraction for T large, justifying the assumption $r \in \widehat{\mathcal{D}}_{X_0, T}$.

- As convergence is locally uniform on \widehat{F}^+ , by the parametrized fixed point theorem the dependence of r on x_0 is continuous. So the map $r^+ : \widehat{F}^+ \rightarrow \mathbb{R}^{dn}$ is continuous, too.

Estimates of the derivatives w.r.t. this initial condition proceed like in the proof for the short range case, that is, Theorem 3.3.3.

As stated in Corollary 3.6, for (α, k) -potentials asymptotic velocity $\bar{v}^+ \in C^{k-1}(\widehat{F}^+, \mathbb{R}^{dn})$. So by (5.11), $\Omega^{+,*}$ is continuous, and as smooth as r^+ .

Note, however, that in (5.14) the second derivative of the long range potential V appears. This is different from the case (4.5) of short range potentials, where only the first derivative is needed. Therefore, in comparison with Part 1 of Theorem 3.3, we lose one derivative in Part 2 of Theorem 5.3.

- By Lemma 3.5, $\Omega^{-1, \pm}$ is one to one. So we can invert $\Omega^{-1, \pm}$ on its image, yielding the Møller transformation Ω^\pm . We still have to prove that for any $x_0 = (p_0, q_0) \in \widehat{F}_{\text{loc}}^+$ and its image $X \equiv X(x_0) := \Omega^{+,*}(x_0)$ the Møller transformation is of the form

$$\Omega^+(X) = \lim_{T \rightarrow +\infty} \Omega_T(X) \quad \text{for} \quad \Omega_T := \widehat{\Phi}_{-T} \circ \Phi_{T,0}^D. \quad (5.15)$$

But this means to control r as a function of X instead of x_0 . So the analysis is similar, and we omit it.

This completes the proof of item (1) of the proposition, i.e. of (5.5).

Proof of part 2 of the theorem.

The intertwining property (5.6) follows by first noting that for Ω_T^{-1} from (5.10)

$$\Omega_T^{-1} \circ \widehat{\Phi}_t = (\Phi_{0,T}^D \circ \Phi_{T+t,0}^D) \circ \Omega_{T+t}^{-1}$$

follows by applying the groupoid property (5.9), and by (5.2),

$$\Phi_{0,T}^D \circ \Phi_{T+t,0}^D(p, q) = (p, q + tv + W(T+t; p, q) - W(T; p, q)).$$

Then $\lim_{T \rightarrow +\infty} \Phi_{0,T}^D \circ \Phi_{T+t,0}^D = \Phi_t^{(0)}$, since using (5.3)

$$\lim_{T \rightarrow +\infty} (W(T+t; p, q) - W(T; p, q)) = \lim_{T \rightarrow +\infty} \int_T^{T+t} \nabla_p V(\langle s \rangle \mathcal{M}^{-1} p) ds = 0.$$

- As a locally uniform limit of symplectomorphisms Ω_T in C^1 norm, for $k \geq 3$ the Dollard-Møller transformation Ω^+ is a symplectomorphism onto its image. This is shown by suitably modifying the proof of Theorem 3.3.3.

This completes the proof of item 2 of the proposition.

Proof of part 3 of the theorem.

The analog of (5.7) follows from (3.1), as the Dollard dynamics (5.2) conserves momentum. *This completes the proof of item 3.*

Proof of part 4 of the theorem.

The proof relies on Lemma 5.8 below, the conjugacy relation (5.6) which forms part 3 just proved, and the relation (5.17) proved below.

Let us write \mathcal{P}_v for the space of all trajectories $x(t)$ having $v^+(x(t)) = v$ where $v \notin \Delta$ is fixed. Let $\pi^\perp : \mathbb{R}^{dn} \rightarrow v^\perp$ be the orthogonal projection so that $\pi^\perp(w) = w - (v\langle w, v \rangle / |v|^2)$. Define a map

$$\mathcal{P}_v \times \mathcal{P}_v \rightarrow v^\perp$$

$$(x, x^{(0)}) \mapsto \lim_{t \rightarrow \infty} \pi^\perp((q(t) - q^{(0)}(t))) =: b(x, x^{(0)}) \in v_*^\perp \quad (5.16)$$

where we've written by $x(t) = (p(t), q(t))$, $x^{(0)}(t) = (p^{(0)}(t), q^{(0)}(t))$ for two trajectories, i.e. points in \mathcal{P}_v . By Lemma 5.8 this limit exists and is independent of where we start on the orbits: shifting $x(t)$ to $x(t+t_1)$ and $x^{(0)}(t)$ to $x^{(0)}(t+t_0)$ yields $\lim_{t \rightarrow \infty} (q(t+t_1) - q^{(0)}(t+t_0)) = \lim_{t \rightarrow \infty} (q^{(1)}(t) - q^{(0)}(t)) + (t_1 - t_0)v$ so leaves the map (5.16) unchanged.

Think of one of the orbits, $x^{(0)}$, as the "origin" of \mathcal{P}_v . Then *we must show that the map (5.16), viewed as a function of x alone, is onto, and that its image uniquely determines x up to a time translation.*

It will be important to understand that $x \in \mathcal{P}_v$ iff $\Omega^{-1}(x(0)) = (\mathcal{M}v, \beta)$ for some β . This is an immediate consequence of

$$v^+(x(t)) = v_* \iff \Omega^{-1}(x(0)) = (\mathcal{M}v_*, \beta), \text{ some } \beta \quad (5.17)$$

valid for all escape orbits $x(t)$. To establish the validity of (5.17) recall that the free flow (or the Dollard flow) does not change the momentum component. Write $\Omega^{-1}(x(0)) = (\mathcal{M}v, \beta)$, for some v, β . Let pr_1 denotes the projection onto the momentum factor. Then we have

$$\mathcal{M}v = \text{pr}_1 \Omega^{-1}(x(0)) = \text{pr}_1 \Omega^{-1}(x(t)) = \lim_{t \rightarrow \infty} \text{pr}_1 \Omega^{-1}(x(t))$$

according to the conjugacy relation. By (5.1) the momentum component of $x(t)$ limits to $\mathcal{M}v^+(x(0))$ as $t \rightarrow \infty$. On the other hand, by part 3 of the theorem we are proving - the asymptotic near identity part, see (5.7), the map Ω^{-1} tends to the identity along escape orbits such as $x(t)$:

$$\Omega^{-1}(x(t)) = x(t) + o(1), \text{ as } t \rightarrow \infty.$$

Indeed, the term q_{\min}^α appearing in estimate (5.7) tends to zero like $t^{-\alpha}$ as $t \rightarrow \infty$. It follows that $\lim_{t \rightarrow \infty} \text{pr}_1 \Omega^{-1}(x(t)) = \mathcal{M}v^+(x(0))$, which establishes (5.17).

If Ω^{-1} is mapped *onto* F_0 , then the surjectivity of our map (5.16) would be immediate. Ω^{-1} would map \mathcal{P}_v onto the space of lines parallel to v according to (5.17) and the conjugacy relation. And Ω , being the inverse of Ω^{-1} , would be well-defined with domain all of F_0 and would map straight lines onto asymptotically free trajectories lying in F^+ . We could take $x^{(0)}(t)$ to be $\Omega(\ell_0(t))$ where $\ell_0(t) = (\mathcal{M}v, vt)$ corresponds to $b = 0$. Any $x(t) \in \mathcal{P}_v$ can be written, up to translation, uniquely as $\Omega(\mathcal{M}v, vt + b)$ for some $b \in v^\perp$. Moreover, both Ω and Ω^{-1} tend to the identity along escape orbits so that the limit in (5.16) is the same as the limit achieved using the free flow, and so would yield $b = b(x, x^{(0)})$, and completing the proof.

Ω^{-1} is onto F_0 for non-singular potentials V . To see this fact, observe that we can, in the case of a non-singular potential, form $\Phi_{-t}(x_0)$ for any t and any x_0 . Incompleteness of the backward flow due to collisions was the only thing which prevented the direct Dollard-Møller map Ω , defined as the limit $\Phi_{-T} \circ \Phi_{T,0}^T$ as $T \rightarrow \infty$, from existing and having domain all of F_0 . The analysis we used in part 1 of the current theorem to insure the existence of Ω^{-1} , defined as the limit of $\Phi_{0,T}^D \circ \widehat{\Phi}_T$ as $T \rightarrow \infty$, carries through essentially verbatim to yield the existence of $\Omega : F_0 \rightarrow F^+$ and that it is the inverse of our Ω^{-1} .

We deal with the case of singular potentials by observing that Ω^{-1} does not actually have to be onto, but only onto *modulo the flow*, in order for the argument two paragraphs above to work. For any $v_* \notin \Delta$ and $b \in v_*^\perp$ form (v_*, b) and denote

its forward Dollard orbit by $\Phi_{t,0}^D(v_*, b) := y_D(t; b), t_* \leq t < \infty$. Eventually, for t large enough, we will show that these Dollard orbits lie in the image of Ω^{-1} , and that moreover Ω^{-1} is invertible there. Then the entire Dollard ray $y_D([t_*, \infty); b)$ will lie in the image of Ω^{-1} and this will be enough. To this end, fix any relatively compact neighborhood K of the origin in the full phase space $\mathbb{R}^{dn} \times \mathbb{R}^{dn}$. Then there is a t large enough so that $K_t := y_D(t) + K \subset F_{\text{loc}}^+ \subset F^+$. To see this, observe that as t increases without bound the estimates of 1.9 must eventually hold since the q_i occurring in the estimate are equal to tv_*, i to leading order while the v_i are $v_{*,i}$. It thus follows from Theorem 1.14 that $K_t \subset F^+$ for all sufficiently large t . Now, as we saw a few paragraphs above, part 3 (just proved; see also (5.7)) tells us that the map Ω^{-1} on K_t is of the form $Id + h_t$ with $h_t = o(1)$ as $t \rightarrow \infty$. As soon as t is large enough so that the C^{k-1} -norm of h_t on K_t is less than 1 we have that Ω^{-1} is invertible and that $y_D(t) \in \Omega^{-1}(K_t) \cap K_t$. We can let t increase since the estimates only get better and in this way conclude that the entire future Dollard ray $y_D([t_*, \infty); b)$ lies in the image of Ω^{-1} , for some $t_* = t_*(v_*, b)$. Also Ω , the inverse of Ω^{-1} exists along the Dollard ray. This analysis applies to any b , including $b = 0$. Now take $v = v_*$. Take for the ‘origin’ of our trajectory space \mathcal{P}_v the solution $x^{(0)}(t) = \Omega(y_D(t; 0))$. Then

$$b(x, x^{(0)}) = \lim_{t \rightarrow \infty} q(t) - q_0(t) = \lim_{t \rightarrow \infty} \text{pr}_2(y_D(t; b) - y_D(t; 0)) = b,$$

where $\text{pr}_2(p, q) = q$ is the projection onto configuration space. We have proved that the map (5.16) is onto.

Finally, to see that the map $x \mapsto b(x, x^{(0)})$ of (5.16) determines the trajectory x up to time translation use that fact that the same map determines the trajectory up to time translation over on the free side, and that the free and Newtonian limits are equal since Ω^{-1} tends to the identity along escaping orbits. \square

5.4 Remark See also the remark in DEREZIŃSKI and GÉRARD [DG, p. 24] regarding the affine structure of the tangent space and part 4.

5.5 Remark (Derivation of asymptotics (5.1)) Set $\Phi_t^D = \Phi_{t,0}^D$ so that $\Omega^{-1} = \lim_{t \rightarrow \infty} (\Phi_t^D)^{-1} \circ \Phi_t$. It follows that for t large we have $\Phi_t^D \circ \Omega^{-1} = \Phi_t + o(1)$. But Ω^{-1} tends to the identity along escaping orbits $x(t)$. This yields $\Phi_t^D(x(T)) = \Phi_t(x(T)) + o(1)$ for T sufficiently large, $t \rightarrow \infty$ which is (5.1). \diamond

5.6 Remark (Homogeneous potentials)

If V is a $(-\alpha)$ -homogeneous potential, then for every $k \in \mathbb{N}$, V is an (α, k) -potential. So in particular the Dollard-Møller transformation is C^∞ -smooth. \diamond

5.7 Earlier results

1. As we have indicated above, the assumption $\alpha \in (1/2, 1]$ in Theorem 5.3 can be relaxed, by generalizing the two-body technique from HERBST [He]. The price to be payed is a Dollard dynamics that is more involved than (5.2).
2. Theorem 1 of SAARI [Sa] states for the gravitational n -body system that under a non-oscillation assumption the centers of mass of clusters asymptotically either move like $t \mapsto vt + D \log(t) + o(\log(t))$, or their mutual distances are of order $\mathcal{O}(t^{2/3})$. As this allows for non-trivial clusters, Saari's result is not contained in the statement of Theorem 5.3. On the other hand, Theorem 5.3 concerns general long range potentials and controls the asymptotics of the flow, not just of individual orbits.
3. As Lemma 5.8 below shows, orbits with equal asymptotic momentum \bar{p}^+ synchronize their relative positions, although their momenta \tilde{p} approach \bar{p}^+ only slowly ($\tilde{p}(t) - \bar{p}^+ = \mathcal{O}(t^{-\alpha})$). See also HERBST [He, Lemma II.2] for the case of potential scattering. \diamond

5.8 Lemma (Orbits with equal asymptotic velocity)

For a long range potential V , consider initial conditions $x_0^{(i)} \equiv (p_0^{(i)}, q_0^{(i)}) \in \widehat{F}^\pm$ ($i = 1, 2$), whose asymptotic momenta $\bar{p}^+(x_0^{(i)})$ respectively $\bar{p}^-(x_0^{(i)})$ coincide. Then

$$\Omega^{-1, \pm}(x_0^{(2)}) - \Omega^{-1, \pm}(x_0^{(1)}) = \left(0, \lim_{t \rightarrow \pm\infty} (q(t, x_0^{(2)}) - q(t, x_0^{(1)})) \right). \quad (5.18)$$

In particular, the limit on the right in (5.18) is finite when the $x_0^{(i)}$ yield solutions having the same asymptotic velocities (or momenta).

5.9 Remark (Difference between long range and short range case)

Note that the limits $\lim_{t \rightarrow \pm\infty} (\Phi_t(x_0^{(i)}) - \Phi_{t,0}^D \circ \Omega^{*, \pm}(x_0^{(i)}))$ do not exist for $(-\alpha)$ -homogeneous potentials and $\alpha \in (0, 1)$, see Appendix C. \diamond

Proof of Lemma 5.8: With a^\pm from (3.11) and Ω_t from (5.15) we have

$$\begin{aligned} (0, a^\pm) &\stackrel{(1)}{=} \lim_{t \rightarrow \pm\infty} (p(t, x_0^{(2)}) - p(t, x_0^{(1)}), q(t, x_0^{(2)}) - q(t, x_0^{(1)})) \\ &\stackrel{(2)}{=} \lim_{t \rightarrow \pm\infty} (\Phi_{t,0}^D \circ \Omega_t^{-1}(x_0^{(2)}) - \Phi_{t,0}^D \circ \Omega_t^{-1}(x_0^{(1)})) \\ &\stackrel{(3)}{=} \lim_{t \rightarrow \pm\infty} (\Omega_t^{-1}(x_0^{(2)}) - \Omega_t^{-1}(x_0^{(1)})) \stackrel{\text{def.}}{=} \Omega^{-1, \pm}(x_0^{(2)}) - \Omega^{-1, \pm}(x_0^{(1)}), \end{aligned}$$

since

- By assumption $\bar{p}^\pm(x_0^{(i)}) = \lim_{t \rightarrow \pm\infty} p(t, x_0^{(i)})$ coincide, and by Lemma 3.5 $a^\pm = \lim_{t \rightarrow \pm\infty} (q(t, x_0^{(2)}) - q(t, x_0^{(1)}))$ exists, proving (1).

- Identity (2) follows from $\Phi_{t,0}^D \circ \Omega_t^{-1} = \Phi_{t,0}^D \circ \Phi_{0,t}^D \circ \widehat{\Phi}_t = \widehat{\Phi}_t$, see (5.9).
- The Dollard dynamics Φ^D , see (5.2), does not change momentum, which implies equality of the first components in (3). Concerning the second components,

$$Q(-t, p(t, x_0^{(i)})) = q(t, x_0^{(i)}) - \mathcal{M}^{-1}p(t, x_0^{(i)})t - \int_0^t \nabla_p V(\langle s \rangle \mathcal{M}^{-1}p(t, x_0^{(i)})) ds$$

and $\|p(t, x_0^{(2)}) - p(t, x_0^{(1)})\| = \mathcal{O}(|t|^{-1-\alpha})$, see (3.12). So

$$Q(-t, p(t, x_0^{(2)})) - q(t, x_0^{(2)}) = Q(-t, p(t, x_0^{(1)})) - q(t, x_0^{(1)}) + \mathcal{O}(|t|^{-\alpha}),$$

proving (3). \square

Finally we prove a property special to (-1) -homogeneous potentials: the existence of the Dollard-Møller transformation *and* of asymptotes. This property does not extend to $(1, k)$ -potentials or to $(-\alpha)$ -homogeneous potentials, $0 < \alpha < 1$, as counterexamples on the half-line show.

5.10 Proposition (Asymptotes for (-1) -homogeneous potentials)

Let V be a (-1) -homogeneous potential and $\Phi_{\bullet, \bullet}^D$ its Dollard flow (5.2).

Then for all initial conditions $x_0 \in \widehat{F}^\pm$ there exist unique $X_0^\pm \in F_0$ with

$$\lim_{t \rightarrow \pm\infty} (\Phi_{t,0}^D(X_0^\pm) - \widehat{\Phi}_t(x_0)) = 0.$$

In fact, $X_0^\pm = \Omega^{*,\pm}(x_0)$.

Proof:

The proof crucially relies on Appendix B. We show the result for the limit $t \rightarrow +\infty$ and omit the superscript \pm of X_0^\pm . To make clear that $\alpha = 1$ is the unique power with the described property, we first allow for α -homogeneous potentials with $\alpha \in (1/2, 1]$.

We set $x(t) \equiv (p(t), q(t)) := \widehat{\Phi}_t(x_0)$ and $X(t) \equiv (P(t), Q(t)) := \Phi_{t,0}^D(X_0)$ for the Dollard flow with initial conditions $X_0 := \Omega^{*,+}(x_0)$ and show that the limit $\lim_{t \rightarrow +\infty} (X(t) - x(t))$ exists iff $\alpha = 1$.

For all $t \in \mathbb{R}$ we have $P(t) = \bar{p}^+(x_0) = \lim_{t \rightarrow +\infty} p(t)$. So we must consider

$$\begin{aligned} F(t) &:= Q(t) - q(t) = Q_0 + \bar{v}^+(x_0)t + \int_0^t \nabla_{\bar{p}^+} V(\langle s \rangle \mathcal{M}^{-1} \bar{p}^+(x_0)) ds - q(t) \\ &= Q_0 + \bar{v}^+(x_0)t + f_\alpha(t) \mathcal{M}^{-1} \nabla V(\bar{v}^+(x_0)) - q(t), \end{aligned}$$

(See Appendix B.) Its time derivative equals for $t > 0$

$$\begin{aligned}
\dot{F}(t) &= \bar{v}^+(x_0) + \langle t \rangle^{-\alpha} \mathcal{M}^{-1} \nabla V(\bar{v}^+(x_0)) - \dot{q}(t) \\
&= \mathcal{M}^{-1} \left[\int_t^\infty \nabla V(q(s)) ds + \langle t \rangle^{-\alpha} \nabla V(\bar{v}^+(x_0)) \right] \\
&= \mathcal{M}^{-1} \left[\int_t^\infty \nabla V(\bar{v}^+(x_0)s + \mathcal{O}(s^{1-\alpha} \log(s))) ds + \langle t \rangle^{-\alpha} \nabla V(\bar{v}^+(x_0)) \right] \\
&= \mathcal{M}^{-1} \left[\int_t^\infty \nabla V(\bar{v}^+(x_0)s) ds + \langle t \rangle^{-\alpha} \nabla V(\bar{v}^+(x_0)) \right] + \mathcal{O}(t^{-2\alpha} \log(t)) \\
&= [\langle t \rangle^{-\alpha} - \alpha^{-1} t^{-\alpha}] \mathcal{M}^{-1} \nabla V(\bar{v}^+(x_0)) + \mathcal{O}(t^{-2\alpha} \log(t)).
\end{aligned}$$

We used $(-\alpha)$ -homogeneity of V in the second to last equation. To avoid a distinction of cases, we kept an $\mathcal{O}(\log(t))$ term, that is unnecessary if $\alpha \in (1/2, 1)$.

So if $\alpha = 1$, then the first term is of order $\mathcal{O}(t^{-3})$, and only in this case $\lim_{t \rightarrow +\infty} (Q(t) - q(t))$ exists. Subtracting this limit from Q_0 , if non-zero, gives the unique initial conditions of the Dollard flow that yield an asymptote.

However, for $\alpha = 1$ we have $\lim_{t \rightarrow +\infty} (Q(t) - q(t)) = 0$: We just proved that the difference of the momentum $p(t)$ (which equals the momentum component of $\Omega_t^{*,+}(x_0)$) and of $P(t)$ is of order $\mathcal{O}(t^{-2} \log(t))$. So the difference of the positions of the time t Dollard flow with initial conditions $(P_0, Q_0) := X_0 = \Omega^{*,+}(x_0)$ and $(P_t, Q_t) := X_t := \Omega_t^{*,+}(x_0)$ is

$$\begin{aligned}
Q(t) - (Q_t + t \mathcal{M}^{-1} p(t) + f_1(t) \nabla_{p(t)} V(\mathcal{M}^{-1} p(t))) & \tag{5.19} \\
&= [Q_0 - Q_t] + [\bar{v}^+(x_0) - \mathcal{M}^{-1} p(t)] t \\
&\quad + \sinh^{-1}(t) \left[\nabla_{\bar{p}^+(x_0)} V(\mathcal{M}^{-1} \bar{p}^+(x_0)) - \nabla_{p(t)} V(\mathcal{M}^{-1} p(t)) \right].
\end{aligned}$$

By definition of the Dollard-Møller transformation $\lim_{t \rightarrow \infty} [Q_0 - Q_t] = 0$, whereas $[\bar{v}^+(x_0) - \mathcal{M}^{-1} p(t)] t = \mathcal{O}(t^{-1} \log(t))$, and

$$\sinh^{-1}(t) \left[\nabla_{\bar{p}^+(x_0)} V(\mathcal{M}^{-1} \bar{p}^+(x_0)) - \nabla_{p(t)} V(\mathcal{M}^{-1} p(t)) \right] = \mathcal{O}(\log(t) \cdot t^{-2} \log(t)).$$

So the difference (5.19) has limit zero. \square

6 On the scattering relation and map

When we replace limits $t \rightarrow \infty$ by $t \rightarrow -\infty$ we arrive at the analogous objects for backward time, such as

$$v^-(x_0) = \lim_{t \rightarrow -\infty} q(t; x_0)/t,$$

in definition 1.6. In this way we arrive at the backward time analogue of being “free”, which is to be in the set

$$F^- := \{x \in P : \text{the solution through } x \text{ is backward free}\},$$

and the backward Möller transform

$$\Omega_- := \lim_{t \rightarrow -\infty} \Phi_{-t} \circ \Phi_t^0 : P \rightarrow P.$$

If $x_0 \in F^- \cap F^+$ then both $v^+(x_0)$ and $v^-(x_0)$ are defined, which leads us to the *scattering relation* \sim_s on $\mathbb{R}^{dn} \setminus \Delta$ under which $v^- \sim_s v^+$ if and only if there exists an $x_0 \in F^- \cap F^+$ such that $v^-(x_0) = v^-$ and $v^+(x_0) = v^+$. Borrowing from quantum mechanics, the “S-matrix” or scattering map is defined by

$$S := \Omega_+^{-1} \circ \Omega_-.$$

S takes an “initial condition” (p_-, C_-) at time $t = -\infty$ to an $x_0 \in F^- \cap F^+$ and then takes this x_0 to the (p_+, C_+) at $t = +\infty$ to which its solution corresponds. Observe that $p_{\pm} = \mathcal{M}v^{\pm}(x_0)$ so that the projection of the *graph* of the scattering map onto its momentum components p_-, p_+ yields the scattering relation (times the mass matrix \mathcal{M}). We will leave this work to future researchers or future times.

6.1 Remark (Manifold at infinity)

For an alternate construction of the scattering map which is valid for long range potentials and in particular for the Newtonian potential, see [DMMY]. In this version S is defined by adding a manifold at infinity and identifying the asymptotic velocities v_-, v_+ with equilibrium points at infinity. \diamond

Appendices

In these appendices we go over some aspects of Dollard flows and the induced transformations in a more leisurely fashion. Hamiltonians for homogeneous potential are computed in Appendix B. There we get two interesting surprises: first, that a solution to the Dollard dynamics admits an asymptote if and only if the initial velocity $a = \mathcal{M}^{-1}p$ is a central configuration in the sense of celestial mechanics. The second surprise is the appearance of hypergeometric functions. In Appendix C we show that for $0 < \alpha < 1$ one can actually define two Dollard dynamics. One admits asymptotes but no Møller transformation. The other, essentially the one we use, admits no asymptotes but does yield a Møller transformation. For $\alpha = 1$ these two are equal, and this happy coincidence gives the method more power here. See Proposition 5.10.

A Precursors to Dollard-Møller

We explore two alternatives to the Møller transformation, by way of examples.

A.1 Example (Kepler-Møller transformation for the n -center problem)

After regularization, the motion of a single particle in the n -center potential $V(q) := -\sum_{k=1}^n \frac{Z_k}{\|q-s_k\|}$ with $Z_k \in \mathbb{R}$ and $s_k \in \mathbb{R}^3$ leads to a complete, smooth flow Φ . By comparing the n -center flow with the regularized flow $\Phi^{(K)}$ of the Kepler Hamiltonian $H^{(K)}(p, q) := \frac{1}{2}\|p\|^2 - \frac{Z_\infty}{\|q\|}$ with $Z_\infty := \sum_{k=1}^n Z_k$, we can define a modified Møller transformation which exist for all initial values x with $H^{(K)}(x) > 0$, and which is smooth. See [Kn, section 6]. \diamond

In the case of the gravitational n -body problem we do not know of any *time-independent* comparison Hamiltonian dynamics which yields an explicit integrable flow and also yields a well-defined Møller transformation.

A.2 Example (Asymptotes and Galilean boosts)

A positive *asymptote* for a solution curve $t \mapsto q(t, x)$ to Newton's equations is, by definition, an affine line $L_+ \subseteq \mathbb{R}^{dn}$ in configuration space whose distance $\min_{\tilde{q} \in L_+} \|q(t) - \tilde{q}\|$ to the solution curve vanishes as $t \rightarrow +\infty$. In a similar manner we define a negative asymptote L_- by insisting its distance to the solution goes to zero as $t \rightarrow -\infty$. Assuming that the asymptotic velocities $v^\pm(x)$ of a solution exist and are not zero, then $\lim_{t \rightarrow \pm\infty} \|q(t, x)\| = \infty$, and if an asymptote L exists, it is necessarily unique. It is often the case that the asymptotes exist:

- Solutions corresponding to short range potentials V in the free region F^+ (definition 1.6) always have asymptotes. This follows from the existence of inverse Møller transformation, proven in Theorem 3.3.3.
- Although the Kepler potential (or Newtonian 2-body problem) is not short range, in the center of mass coordinates every Kepler hyperbola has asymptotes in both directions.
- Similarly, a particle moving along a bi-hyperbolic orbit under the influence of the gravitational or electrostatic potential due to n centers admits both positive and negative asymptotes, see [Kn, section 6].

The space of oriented affine lines in Euclidean \mathbb{R}^k is naturally diffeomorphic to the cotangent bundle of the sphere S^{k-1} , and in particular can be equipped with a symplectic form. For an n -body problem in d -dimensions, we have $k = nd$ and may try to construct a substitute for the Møller transformation by sending $L_-(x_0) \mapsto L_+(x_0) \in T^*S^{k-1}$, where $L_\pm(x_0)$ are the positive and negative asymptotes of the initial condition x_0 . With some luck, $L_\pm(x_0)$ might exist for all

$x_0 \in F^+ \cap F^-$ and we would then have our scattering map as a map between open subsets T^*S^{k-1} , a symplectomorphism even if the asymptotics of solutions depended sufficiently smoothly on the initial condition x_0 . See for example [Kn, section 16].

Galilean boosts destroy the existence of asymptotes, so that we cannot expect asymptotes to exist for general long range potentials. To see this destruction phenomenon, take for simplicity $n = 2$, $d = 1$ and $m_1 = m_2 = 1$. The Newtonian two-body equations read $\ddot{q}_1 = (q_2 - q_1)/r^3$, $\ddot{q}_2 = (q_1 - q_2)/r^3$ with $r = |q_1 - q_2|$. The reduced mass is $\mu = 1/2$ so that the corresponding Kepler problem becomes $\ddot{x} = -2x/|x|^3$, $x = q_1 - q_2$. A hyperbolic solution $q(t) = (q_1(t), q_2(t))$ with asymptotic energy 1 in the center of mass frame $q_1 + q_2 = 0$ will have asymptotics $q_1(t) = t + 2\log(t) + c + o(1)$, $q_2(t) = -t - 2\log(t) - c + o(1)$. Apply the Galilean boost $(q_i, t) \mapsto (q_i + tv, t)$ to this solution to obtain a new two-body solution $\tilde{q} = (\tilde{q}_1, \tilde{q}_2)$ whose asymptotic expansion is

$$\begin{aligned}\tilde{q}_1(t) &= t + vt + 2\log(t) + c + o(1), \\ \tilde{q}_2(t) &= -t + vt - 2\log(t) - c + o(1).\end{aligned}$$

Now, the signed distance between a point $Q = (x, y)$ and a line $L \subseteq \mathbb{R}^2$ is given by the affine expression $d(Q, L) = u \cdot Q + e = ax + by + e$ where $u = (a, b)$ is the unit vector perpendicular to the direction of L and where e is the distance between L and $(0, 0)$. Consequently the signed distance between our putative L and our moving solution $(\tilde{q}_1(t), \tilde{q}_2(t))$ must have the form

$$a(t + vt + 2\log(t)) + b(-t + vt - 2\log(t)) + e + o(1).$$

Expanding out we find that this signed distance has asymptotic expansion $(a - b + 2v)t + 2(a - b)\log(t) + e + o(1)$. For this distance to tend to zero with t we must have that $a - b + 2v = 0$ as well as $a - b = 0$ which is impossible if $v \neq 0$. \diamond

The latter example shows that we cannot use asymptotic affine lines to model scattering for long range potentials. We do not know how to use a time independent model flow as a replacement to free flow, or the Kepler flow of the previous example either.

B Dollard and central configurations for homogeneous potentials

Take V to be one of the power law potentials of homogeneity $-\alpha$, $\alpha \in (1/2, 1]$, as defined by (3.13). These potentials are strictly long range, that is, they are

long range and not short range.² The main interest is of course in the case $\alpha = 1$, including gravitational or electrostatic interactions.

We first note that, although the potential V is unbounded in our case, the statements of Theorem 3.3 concerning long-range pair interactions apply, since for any $k \in \mathbb{N}$ the norms (2.3) are still finite for these homogeneous potentials.

The proper Dollard Hamiltonian $V(\langle t \rangle \mathcal{M}^{-1}p)$ equals

$$\tilde{H}_t^D(p, q) = \langle t \rangle^{-\alpha} \sum_{1 \leq i < j \leq n} \frac{I_{i,j}}{\|v_i - v_j\|^\alpha} \quad (t \in \mathbb{R}), \quad (\text{B.1})$$

and for W , defined in (5.3), we explicitly get

$$\int_0^t \nabla_p V(\langle s \rangle \mathcal{M}^{-1}p) ds = \int_0^t \langle s \rangle^{-\alpha} ds \nabla_p V(\mathcal{M}^{-1}p) = f_\alpha(t) \nabla_p V(\mathcal{M}^{-1}p),$$

with $f_\alpha \in C^\infty(\mathbb{R}, \mathbb{R})$, $f_\alpha(t) := t {}_2F_1\left(\frac{1}{2}, \frac{\alpha}{2}; \frac{3}{2}; -t^2\right)$ being odd, and ${}_2F_1$ denoting the hypergeometric function. For $\alpha = 1$ this simplifies to $f_1(t) = \sinh^{-1}(t)$. Moreover,

$$\nabla_p V(\mathcal{M}^{-1}p) = \left(\sum_{k \in N \setminus \{1\}} \frac{-\alpha I_{k,1}(v_k - v_1)}{m_1 \|v_k - v_1\|^{\alpha+2}}, \dots, \sum_{k \in N \setminus \{n\}} \frac{-\alpha I_{k,n}(v_k - v_n)}{m_n \|v_k - v_n\|^{\alpha+2}} \right).$$

Recall the following definition, which actually does not demand that the potential be homogeneous.

B.1 Definition A vector $x \in \mathbb{R}^{dn} \setminus \Delta$ is called a *central configuration* if it is linearly dependent with respect to $\mathcal{M}^{-1} \nabla V(x)$.

We see from the definition (5.3) of W and the last formulae above that for these $(-\alpha)$ -homogeneous potentials the Dollard dynamics has an asymptote in the sense of Example A.2 if and only if v is a central configuration.³

C Dollard dynamics

The point of this appendix is to show that a Dollard dynamics cannot both lead to asymptotics for the scattering solution *and* existence of Møller transformations. Our work here follows the ideas of Herbst [He].

For $\alpha = 1$ the Hamiltonian (B.1) is a classical analogue of the quantum ansatz introduced by DOLLARD in [Do]. For the potential scattering of two particles,

²The $(-\alpha)$ -homogeneous potentials with $\alpha > 1$ are of short range. So the time-independent kinetic Hamiltonian K can be used for defining the Møller transformations.

³This has been noted independently by Alain Albouy (private communication with A.K.)

HERBST translated Dollard's ideas to the classical case and generalized them to long range potentials in his interesting article [He]. See also [DG, section 1.12].

Herbst actually describes *two* different natural definitions of a Dollard Hamiltonian for $(-\alpha)$ -homogeneous potentials, when $\alpha \in (0, 1)$. We proceed to describe and analyze these in the one-dimensional case ($d = 1$).

So consider the Hamiltonian flow of $H : T^*\mathbb{R}^+ \rightarrow \mathbb{R}$, $H(p, q) := \frac{1}{2}p^2 + V(q)$ with $V(q) := I/q^\alpha$. For initial conditions $x_0 = (p_0, q_0)$ with velocity $p_0 > 0$ and $h := H(p_0, q_0) > 0$ the asymptotic velocity p^+ equals $\sqrt{2h}$. By assuming $\alpha \in (1/2, 1)$, we avoid the necessity of multiple iterations of integral equations, which would only blur the basic phenomenon.

As $\ddot{q} = \alpha I q^{-1-\alpha}$, in the large time asymptotics the solution has the form

$$q(t; p_0, q_0) = p^+ t - \frac{I((q_0 + p^+ t)^{1-\alpha} - q_0^{1-\alpha})}{(1-\alpha)(p^+)^2} + q_0 + \delta q_\alpha(p^+, q_0) + \mathcal{O}(t^{1-2\alpha}), \quad (\text{C.1})$$

for $\alpha \in (1/2, 1)$, respectively

$$q(t; p_0, q_0) = p^+ t - \frac{I}{(p^+)^2} \log(1 + p^+ t/q_0) + q_0 + \delta q_1(p^+, q_0) + \mathcal{O}(t^{-1} \log(t))$$

for $\alpha = 1$, with $\lim_{q_0 \rightarrow \infty} \delta q_\alpha(p^+, q_0) = 0$.

- We apply *Herbst's second method*, leading to a Dollard type Møller transformation (Theorem III.1 of [He]). Thus we obtain a sequence of time dependent Hamiltonians $H_t^{(k)}(p) := \frac{1}{2}p^2 + U^{(k)}(p, t)$ for

$$U^{(0)}(p, t) := 0 \quad , \quad U^{(k+1)}(p, t) := V\left(pt + \int_0^t D_1 U^{(k)}(p, s) ds\right),$$

independent of q but dependent on the asymptotic velocity p . So

$$U^{(1)}(p, t) = \frac{I}{(pt)^\alpha} \quad , \quad U^{(2)}(p, t) = I \left(pt \left(1 - \frac{\alpha I (pt)^{-\alpha}}{(1-\alpha)p^2} \right) \right)^{-\alpha}.$$

For $\alpha \in (1/2, 1)$ the solutions of the Hamiltonian equations for $H^{(k)}$ are

$$q^{(0)}(t; p^+, q_0) = p^+ t + q_0 \quad , \quad q^{(1)}(t; p^+, q_0) = p^+ t - \frac{\alpha}{1-\alpha} \frac{I}{(p^+)^{1+\alpha}} t^{1-\alpha} + q_0; \quad (\text{C.2})$$

$q^{(k)}$ for $k \geq 2$ give corrections to $q^{(1)}$ with negative asymptotic order in t .

Now if one compares $q^{(1)}$ in (C.2) with the asymptotics (C.1) of the true solution, then one notices in the term asymptotic to a multiple of $t^{1-\alpha}$ an additional factor α .

Without much calculation, one sees that the inverse Møller transform $(\Omega^+)^{-1}$ exists for initial condition $x_0 := (p_0, q_0)$ with $q_0 := 0_+$: Then by (C.1) the solution of the initial value problem with Hamiltonian H equals

$$\begin{aligned} p(t; x_0) &= p^+ - \frac{I}{(p^+)^{1+\alpha}} t^{-\alpha} + \mathcal{O}(t^{-2\alpha}), \\ q(t; x_0) &= p^+ t - \frac{I}{(1-\alpha)(p^+)^{1+\alpha}} t^{1-\alpha} + \delta q + \mathcal{O}(t^{1-2\alpha}). \end{aligned}$$

Note that by our assumption $\alpha \in (1/2, 1)$ the function $t \mapsto t^{-2\alpha}$ is in $L^1([1, \infty))$. For $x_1 := (p_1, q_1)$ we have by (C.2)

$$q^{(1)}(-t; x_1) = -p_1 t + \frac{\alpha I}{(1-\alpha)p_1^{1+\alpha}} t^{1-\alpha} + q_1. \quad (\text{C.3})$$

Setting $x_1 := (p(t; x_0), q(t; x_0))$, we get convergence of (C.3) as $t \rightarrow +\infty$.

- We now apply *Herbst's first method*, leading to a solution whose difference to $q(t; p_0, q_0)$ converges as $t \rightarrow \infty$ (Theorem II.1 of [He]). So we iteratively define functions $z^{(k)}$ of time t and asymptotic momentum p by setting

$$z^{(k)}(0, p) := 0, \quad \dot{z}^{(0)}(t, p) := p \quad \text{and} \quad \dot{z}^{(k+1)}(t, p) := p - \int_t^\infty F(z^{(k)}(s, p)) ds,$$

with force $F(q) := -\nabla V(q) = \alpha I q^{-1-\alpha}$. We obtain $z^{(0)}(t, p^+) = p^+ t$ and

$$z^{(1)}(t, p^+) = p^+ t - \frac{1}{1-\alpha} \frac{I}{(p^+)^{1+\alpha}} t^{1-\alpha}. \quad (\text{C.4})$$

If we compare $z^{(1)}$ from (C.4) with (C.1), we see that the factors of the terms diverging as $t \rightarrow +\infty$ agree. So here the solution (C.1) has a limit $\lim_{t \rightarrow \infty} (q(t; p_0, q_0) - z^{(1)}(t, p^+))$; the same is true for the time derivatives. However, for (C.2) the corresponding limit does *not* exist if $\alpha < 1$.

Due to the appearance of the regularization $\langle t \rangle$ of $|t|$, the Hamiltonian dynamics generated by our Dollard Hamiltonian (B.1) does not coincide with the ones of Herbst's first or second method. \diamond

So we have seen that for general long range potentials a Dollard dynamics cannot both lead to asymptotics for the scattering solution *and* Møller transformations.

A comparison of the α -dependence of $q^{(1)}$ in (C.2) and of $z^{(1)}$ in (C.4) as $\alpha \nearrow 1$ suggests that both properties could coincide for $\alpha = 1$, the Kepler potential. This is indeed the case, as we see in the body of the paper, in Proposition 5.10.

Acknowledgments. The authors thank the two referees for their suggestions to improve the manuscript.

References

- [Ar] V. Arnold: The cohomology ring of the colored braid group. *Mathematical Notes of the Academy of Sciences of the USSR* **138**, 138–140 (1969)
- [Cha] J. Chazy: Sur l'allure du mouvement dans le problème des trois corps quand le temps croît indéfiniment. *Annales scientifiques de l'E.N.S.* **39**, 29–130 (1922)
- [DMMY] N. Duignan, R. Moeckel, R. Montgomery and G. Yu: Chazy-Type Asymptotics and Hyperbolic Scattering for the n -Body Problem. *Archive for Rational Mechanics and Analysis* **238**, 255–297 (2020)
- [DG] J. Dereziński, C. Gérard: Scattering Theory of Classical and Quantum N -Particle Systems. *Texts and Monographs in Physics*. Berlin: Springer 1997
- [Do] J. Dollard: Asymptotic convergence and the Coulomb interaction. *J. Math. Phys.* **5**, 729 (1964)
- [El] J. Elstrodt: Maß- und Integrationstheorie. Berlin: Springer 2009
- [FO] G. Fusco, W. M. Oliva: Integrability of a System of N Electrons Subjected to Coulombian Interactions. *Journal of Differential Equations* **135**, 16–40 (1997)
- [Ge] J. Gerver: Noncollision singularities: do four bodies suffice? *Experimental Mathematics* **12** 187–198 (2003)
- [Gu] E. Gutkin: Continuity of scattering data for particles on the line with directed repulsive interactions. *Journal of Mathematical Physics* **28**, 351–359 (1987)
- [He] I. Herbst: Classical Scattering with Long Range Forces. *Commun. Math. Phys.* **35**, 193–214 (1974)
- [Hu1] W. Hunziker: The S-Matrix in Classical Mechanics. *Commun. Math. Phys.* **8**, 282–299 (1968)
- [Hu2] W. Hunziker: Scattering in Classical Mechanics. In: *Scattering Theory in Mathematical Physics*. Editors: J. A. Lavita, J.-P. Marchand. NATO Advanced Science Institutes (ASI) Series C. Vol. 9, 79–96, 1974
- [Kn] A. Knauf: The n -centre problem of celestial mechanics for large energies. *Journal of the European Mathematical Society* **4**, 1–114 (2002)

- [LL] E. Lieb, M. Loss: Analysis. *Graduate Texts in Mathematics 14*. Providence, American Mathematical Society, 2001
- [MS] Ch. Marchal, D. Saari: On the Final Evolution of the n -Body Problem. *Journal of Differential Equations* **20**, 150–186 (1976)
- [MV] E. Maderna, A. Venturelli: Viscosity solutions and hyperbolic motions: a new PDE method for the N -body problem. *Annals of Mathematics* **192**, 499–550 (2020)
- [Poi] H. Poincaré: Sur les solutions périodiques et le principe de moindre action. *Comptes rendus hebdomadaires de l'Académie des sciences de Paris* **123**, 915–918 (1896)
- [Sa] D. Saari: Expanding Gravitational Systems. *Transactions of the AMS* **156**, 219–240 (1971)
- [Sim] B. Simon: Wave Operators for Classical Particle Scattering. *Commun. Math. Phys.* **23**, 37–49 (1971)
- [Xia] Z. Xia: The existence of noncollision singularities in Newtonian systems. *Annals of Mathematics* **135**, 411–468 (1992)