



HAL
open science

Multi-agent framework based on smart sensors/actuators for machine tools control and monitoring

Xavier Desforges, Bernard Archimède

► **To cite this version:**

Xavier Desforges, Bernard Archimède. Multi-agent framework based on smart sensors/actuators for machine tools control and monitoring. *Engineering Applications of Artificial Intelligence*, 2006, 19 (6), pp.641-655. 10.1016/j.engappai.2006.03.006 . hal-03827037

HAL Id: hal-03827037

<https://hal.science/hal-03827037>

Submitted on 24 Oct 2022

HAL is a multi-disciplinary open access archive for the deposit and dissemination of scientific research documents, whether they are published or not. The documents may come from teaching and research institutions in France or abroad, or from public or private research centers.

L'archive ouverte pluridisciplinaire **HAL**, est destinée au dépôt et à la diffusion de documents scientifiques de niveau recherche, publiés ou non, émanant des établissements d'enseignement et de recherche français ou étrangers, des laboratoires publics ou privés.

**Multi-agent framework based on smart sensors/actuators
for machine tools control and monitoring**

Xavier Desforges*, Bernard Archimède

Laboratoire Génie de Production

Ecole Nationale d'Ingénieurs de Tarbes

47 avenue d'Azereix, 65016 Tarbes, France

* Corresponding author phone: +33 562442769, e-mail: xavier.desforges@enit.fr

Abstract

Throughout the history, the evolutions of the requirements for manufacturing equipments have depended on the changes in the customers' demands. Among the present trends in the requirements for new manufacturing equipments, there are more flexible and more reactive machines. In order to satisfy those requirements, this paper proposes a control and monitoring framework for machine tools based on smart sensor, on smart actuator and on agent concepts. The proposed control and monitoring framework achieves machine monitoring, process monitoring and adapting functions that are not usually provided by machine tool control systems. The proposed control and monitoring framework has been evaluated by the means of a simulated operative part of a machine tool. The communication between the agents is achieved thanks to an Ethernet network and CORBA protocol. The experiments (with and without cooperation between agents for accommodating) give encouraging results for implementing the proposed control framework to operational machines. Also, the cooperation between the agents of control and monitoring framework contributes to the improvement of reactivity by adapting cutting parameters to the machine and process states and to increase productivity.

Key words: Multi-agent system, smart sensor and actuator, control and monitoring, machine tools

1. Introduction

The evolutions of the requirements for manufacturing equipments have always been consequences of the changes in the customers' demands. Today markets increasingly demand more customized high quality

products with shorter life cycles. In such a context, the requirements for new manufacturing equipments deal with the improvement of flexibility, reconfigurability and reactivity. The concept of 'reactivity' becomes relevant because of the need to maintain the productivity of the manufacturing operations with minimum downtime (Molina *et al.*, 2005).

The flexibility has been improved thanks to programmable numerically controlled machine tools. The ability to be programmed has contributed to increase the number of the types of processes that can be achieved by a machine tool and to increase the geometry complexity of the products that can be manufactured.

The productivity, in terms of rapidity, has been improved thanks to the developments of high-speed machining processes. The machine tools that are able to achieve those processes have specific mechanical structures. New functions with adjustable parameters are implemented in their control systems in order to calculate tool trajectories that reduce the effects of undesirable but predictable phenomena that can appear during machining (Renton and Elbestawi, 2000).

The reconfigurability is one of the major concerns in the design of machine tools. Modular structural designs are a way to meet this requirement. Indeed, they enable to provide the needed combination of processes and independent axis control and motion. The modularity is also a concept that is considered for the design of control and monitoring systems of the machine tools which expected features are extendibility, scalability, interoperability and portability (Pritschow *et al.*, 1993; Altintas *et al.*, 1996; Schofield and Wright, 1998, Mehrabi *et al.*, 2002). Object-oriented modelling and programming languages ease the generation of software units of such controllers because they enable the encapsulation, the specialization and the reuse of functionalities (Blaha and Rumbaugh, 2005; Molina *et al.*, 2005).

For machine tools, the reactivity mainly consists in maintaining the productive operation and/or in contributing to reduce downtime when a problem is detected. In order to improve the reactivity of machine tools, many functions have been developed for monitoring and/or diagnosing the machines (Harris *et al.*, 1989; Isermann, 1993) and the productive processes (Dan and Mathew, 1990), and for accommodating or adapting (Carrillo and Rotella, 1997; Liu *et al.*, 2001). Diagnostic functions contribute to reduce downtime by identifying faults without requiring maintenance operators. The implementations of monitoring functions often lead to stop the productive processes when problems occur in order to avoid more damages. Adaptive control functions produce data for their own needs. Those data can be the same as the ones produced by monitoring functions and this may lead to redundancies. The implementations of

such functions often require specific sensors, specific software modules, dedicated treatment units, interfaces with the numerical controllers... Therefore, they are inherently costly. They are also costly because the control systems proposed by manufacturers are still centralized and are not open enough notwithstanding the numerous research developments in the field (Molina *et al.*, 2005). Under such circumstances, those three types of functions are rarely implemented together in the same machine.

The purpose of the paper is to present an alternative control and monitoring framework for machine tools aiming at tackling those limitations. The proposed control and monitoring framework is based on smart sensors/actuators and on a numerical controller with agent abilities that require a new decision level. The proposed system achieves monitoring, diagnosis and adaptive control tasks and aims at satisfying the expectations in terms of flexibility, reconfigurability and reactivity. Before presenting the proposed system and its components, the paper briefly presents smart sensor and actuator concept and its extension according to the notion of agent. Then, it shows how the new decision level is integrated to the control and monitoring structure, what the roles of the different agents are and how the three types of functions can be achieved. The last part presents the experimental platform and the experimental results that are discussed.

2. Extension of the smart sensor and actuator concept to the notion of agent

The smart or intelligent sensor and actuator concept was defined in the 1980s to tackle a lack of reliability in complex systems inherent to numerous sensors and actuators needed for their control and monitoring.

The proposal defined in the concept consists in adding information processing and bi-directional communication abilities to the main service functions of sensors and actuators (Isermann, 1993; Robert *et al.*, 1993). This proposal leads to the physical structures of Smart Sensors and Actuators (SSAs) presented on figure 1. The information processing ability is mainly used for the implementation of functions dealing with:

- measuring,
- monitoring and diagnosing,
- acting safely (adaptive control, accommodation...)
- communicating,
- managing the activity of the instrument,

- managing the internal database.

Those functions are designed to improve (Taner and White, 1996):

- the metrological quality of the provided measures and/or their certainty thanks to validation treatments,
- the reliability of the system by providing reliable information,
- the reliability of the sensor or actuator itself thanks to self-monitoring and self-diagnosis functions.

In most cases, the studies carried out in the field of SSAs are led to develop sensors and actuators dedicated to the achievement of a specific function of a given kind of system (Sente and Buyse, 1995; Xie *et al.*, 1998; Lee *et al.*, 2001). However, the use of SSAs is not entirely satisfying especially for the reaction to disturbances that perturb the nominal functioning of the production system since their behaviors are strongly predetermined.

A way to improve this situation is to give freedom degrees at the SSA level. The management of those freedom degrees requires decision-making abilities carried out by the SSAs. In that way, those SSAs are able to react rapidly when they detect a disturbance by making the appropriate decision according to defined goals and boundaries. The detection of disturbances or of situations that do not satisfy the defined goals requires cooperation between the SSAs as they operate on different parts of the process.

SSAs with decision-making abilities can be considered as agents according to the definition of a computational agent given in (Jennings and Wooldridge, 1995) where an agent is defined as a self-contained problem-solving computational entity able, at least, to perform most of its problem-solving tasks, to interact with its environment, to perceive its environment and to respond within a given time, to take initiatives when it is appropriate. Indeed, measuring and acting are the main solving-problem tasks; measuring, cooperating and communicating are the perception and interaction abilities; making decisions can be considered as a way of taking initiatives.

3. Proposal of a framework for integration

The SSA concept and the agent technology require distributed structures to be brought into operation. A control and monitoring framework must be defined for machine tools because their traditional control structures are centralized.

3.1. Control structure of traditional machine tools

A machine tool is defined to achieve a task or a group of tasks that drive machining processes. It is generally divided in two parts: the control part and the operative part. The operative part of the machine receives orders from the control part. These orders are applied to the actuators and the measurements are sent back by sensors to ensure regulations tasks. The operative part does not have any decision-making ability. The control part should be able:

- to receive, to identify and to process information from the environment,
- to store the information and the results of the process,
- to monitor and to dispatch information to the environment.

The processed information belongs to two different categories:

- the orders received from other intelligent devices (cell pilots, human operators...),
- the information about the state of machine.

The treatments generally correspond to the execution of algorithms. In the case of traditional numerically controlled machine tools, the control system is centralized as shown in figure 2.

In such an organization, there is a single decision center represented by the numerical controller. It gives to the other instruments the instructions (spindle speed reference to the spindle regulator, position references to the axis cards...) according to the work-piece program and parameters that can be changed thanks to the man/machine interface or sent by the cell pilot. The other devices do not have any decisional ability. Indeed, the PLC does not make any decision. It controls the auxiliary systems (tool changer, automated protection gates, lubricating system...) from the orders that the numerical controller sends. It also provides some binary indicators that denote failures and often lead the numerical controller to stop the machining operation or not to start it.

One major drawback of this centralized control system is that it can hardly be enlarged with new functions without the help of the manufacturer. Indeed, numerical control systems are often offered as closed manufacturer-specific solutions (Pritschow *et al.*, 1993). This situation has led to a demand for the development of open and modular control systems expected by the users of flexible manufacturing systems (Mehrabian *et al.*, 2002; Molina *et al.*, 2005). The modularity enables the users to implement the devices and the functions they really need. Many studies contribute to define such structures (Altintas *et al.*, 1996; Pritschow *et al.*, 1993; Schofield & Wright 1998). Although the proposed structures are modular and open, they are still centralized. Indeed, the different modules do not really cooperate

between each other to achieve their functions. The numerical controller directly computes them or they mainly exchange data with it. The implementation of different modules that achieve different functions often leads to redundant data processes. Under such circumstances, we consider they are not relevant enough regarding the objective of reactivity of the machine tools.

3.2 Integration of the additional decision level

Our proposal consists in integrating a new decision level at SSA level. Such a proposal has been developed and presented in (Desforges *et al.*, 2004). This integration is based on SSAs that realize the interface between the control part and the operative part. The SSAs are extended with a decision-making ability. The SSAs involved in the structure behave as smart sensors as well as smart actuators. Indeed, they are able:

- to correct measurements and to isolate faulty sensors,
- to achieve the monitoring of the actuator,
- to estimate process state (tool wear) thanks to the estimation of cutting forces from the actuator state,
- to accommodate the feed speed to keep the cutting force constant thanks to the cooperation between the SSAs and the numerical controller.

This proposal naturally leads to the physical structure presented on figure 3.

The additional decision level is at the interface between the numerical controller and the SSAs as shown on figure 4.

Although this structure is already an alternative to the traditional ones, bringing it into operation seems to be complex and expensive as it requires to define an interface with the operative part (sensors and actuators) for each SSA whereas an interface with the numerical controller unit already exists in traditional numerically controlled machine tools made of a numerical bus and axis control cards.

The framework presented in this paper considers those facilities. Therefore, the operative part of the machine with its sensors and its actuators is considered as a whole as shown on figure 5. The smart sensors/actuators are only computational agents that we then call Computational Smart Sensors/Actuators (CSSAs). The man/machine interface is not represented because it is not considered in the simulation platform but it should belong to the machine level. The auxiliary systems controlled by the PLC are not considered either because they are not directly involved in the machining process which is the only productive task. The framework that we propose is more similar to the traditional machine organization

than the one proposed in figure 3. Indeed, the numerical controller (NC) unit of the traditional machine tool is achieved thanks to a computer, which can easily be connected to a numerical bus to exchange data with the CSSAs. Thus, this structure may ease the implementation of the control and monitoring framework we then propose.

The distributed structure of the additional decisional level is relevant to materialize the cooperation between the CSSAs. In this framework, the cooperation between the CSSAs and the NC unit carries on the decision making process. The reactivity of the system is improved because only the events that require to accommodate or to stop the machining process are transmitted to the machine level. The NC unit does not carry out any regulation tasks.

4. Application of the proposed structure to the control and monitoring of machine tools

The control system is based on CSSAs and on a NC unit agent that have to drive a real-time metal cutting process thanks to an operative part made of the axis feed-drives and of the spindle. The NC unit agent and the CSSAs control and monitor the machining process as well as the machine itself according to defined goals.

4.1. Machining processes goals

Considering metal cutting processes (turning, milling, drilling), the main objective is to machine good quality parts with the highest possible productivity. The quality of parts is often defined in terms of geometry, dimension and surface roughness. The machined part is of a good quality if its dimensions, its geometry and the roughness of its surface are obtained within a given allowance.

Once the cutting process and the tool are chosen, the quality of the part mainly depends on:

- the mechanical structure of the machine, of the fixture and of the tool (elasticity of the mechanical structure and of the tool, backlashes between moving parts...),
- the dynamic behaviors of its servo-drives (feed-drives and spindle),
- the cutting parameters (cutting speed, feed speed, depth of cut),
- the way the trajectories are calculated by the NC unit from the work piece program describing the tool path.

The second main objective is to be productive. This means to produce as many parts as possible at the lowest cost. Therefore, the feed must be as rapid as possible with respect to the specified allowance of the cutting parameters, which are chosen from an abacus, and within the machine capacity. Increasing the tool life saves time and money. Indeed, the costs relative to tools are reduced as tools can be used for more parts; it also reduces the number of tool exchanges that are non-productive operations.

These both objectives are then taken into account to specify the functions achieved by the agents involved in the control and monitoring framework that are the NC unit and the CSSAs.

4.2. Roles and goals of the agents

In the proposed control and monitoring framework, there are two kinds of agents: the NC unit agent and the CSSAs among which we distinguish the axis agents from the spindle agent. Each kind of agent has its own role and its own goals.

The NC unit agent, which main role states to supervise the machining operations and to maintain them as long as possible according to the machine and the process states:

- defines the tool path and the spindle speed reference from the work piece program,
- contains the geometry of the raw part that can be programmed or provided by a CAD-CAM system to compute the depth of cut,
- provides the position references to the axis agents and the spindle speed reference to the spindle agent,
- makes decision about the continuation of the machining operation according the information received from the axis agents and from the spindle agent (estimated tool wear, states of the drives, feed speed or cutting speed out of programmed boundaries).

At the additional decision level, the axis agents and the spindle agent manage two degrees of freedom. They consist in the ability to modify the feed speed and the cutting speed within boundaries that are verified by the NC unit agent. The feed speed and the cutting speed are managed according to the states and the capacities of the spindle and of the feed-drives. The management of those degrees of freedom achieves the ability of adapting or accommodating the machining process to the machine tool state and the process that is here represented by the cutting force. Indeed, assuming steady cutting conditions, the cutting force increases as the cutting edge of tool gets worn (Koren *et al*, 1991; Ravindar *et al.*, 1993).

The axis agents and the spindle agent:

- monitor their own states, diagnose them, store the results and provide them to the NC unit agent if faults are detected,
- check if their maximum capacities have been reached and, according to the test, propose to increase the feed speed and the cutting speed or to decrease them.
- ask the position or the spindle speed reference to the NC unit agent,
- estimate the cutting force components applied on them and request from the other CSSAs and the NC unit the data they need to estimate the tool wear from the downloaded or programmed cutting process model and provide this estimation to the NC unit agent,
- increase or decrease their speeds according to the abilities of the other CSSAs and the boundaries programmed in the NC unit agent.

4.3. Specification of the functions achieved by the agents

One of the goals, presented the introduction of this paper which leads to the definition of the proposed control and monitoring framework consists in the integrated implementation of functions for monitoring, diagnosing and accommodating in order to avoid the implementation of task dedicated modules that often require specific sensors, specific treatment units, specific interfaces and may lead to redundant data processes or measurements. All pieces of information that are computed in the proposed structure are based on the measurements of current, tension, speed and position for each drive. The additional devices that are necessary for the implementation of the proposed structure are redundant current and tension sensors and treatment units dedicated to the agents according to figure 5.

The purpose of this section is to present the methodology we followed to integrate the functions for monitoring, diagnosing and accommodating and how they are implemented in the experimental platform. Here, we also give examples of techniques that enable to provide the expected information without intending to compare them and without being exhaustive.

The functions achieved by the NC unit agent are not detailed because they mainly consist of checking boundaries and of providing the references and the depth of cut to the other agents.

The monitoring functions give information to the system about the machine state and the machining process.

The CSSA agents that estimate the physical parameters of their own drives achieve the machine monitoring. Considering DC motor drives with permanent magnets, the estimated parameters are, the

inductance L , the resistance R , the torque or counter electromotive force constant K , the total moment of inertia on the motor shaft J , the viscous friction coefficient considered on the motor shaft V and the dry friction torque on the motor shaft D . A behavioral model of such drives is given by the following equations:

$$\begin{aligned} \dot{i} + Ri \\ u - Kw = L \end{aligned} \quad (1)$$

$$\begin{aligned} \dot{w} + Vw + D\text{sign}(w) \\ Ki - l = J \end{aligned} \quad (2)$$

where u is the tension, i the induced current, w the motor shaft angular speed and l the load torque on the motor shaft that depends on the cutting force. Several methods can be implemented to estimate of physical parameters of continuous models like the one made of the relationships (1) and (2). In the field, Söderström *et al.* (1997) propose a method based on approximation of the derivative operator. Another method based on pattern recognition ability of artificial neural networks is presented in (Desforges and Habbadi, 1997) that provides the estimations of the physical parameters of DC motor drives. The method implemented in the experimental platform consists in using a same first order low pass filtering described for a signal x by equation (3).

$$x_f = \frac{1}{1 + Ts} x \quad (3)$$

where s is the Laplace operator and x_f the filtered signal. The signals u , i and w are filtered. In equation (1) and (2), the filtered signals u_f , i_f and w_f replace the non filtered ones and \dot{x}_f is replaced by:

$$\dot{x}_f = \frac{x - x_f}{T} \quad (4)$$

The implemented estimator is the recursive least squares algorithm. The parameters of the equation (1) are estimated before the one of equation (2).

The interest in estimating the physical parameters of the drives is the possibility to set relationships between them and faults (see table 1). Those parameters may then be used for diagnostic purpose. The estimation of the parameters is processed while there is no machining process ($l=0$) to avoid estimation errors. For a feed-drive, this estimation may be processed during high-speed motions. For a spindle, this estimation may be processed during the start period. Here, the monitoring of the power converter is not

considered because it requires rapid data processing to observe the behaviors of the switches even if u , i and w are usually measured for regulation and power conversion. The numerical regulation is assumed to be perfect. The estimated parameters may be stored in the historical database of the CSSA agents and may be sent to remote units for diagnosis, predictive or proactive maintenance purposes (Léger and Morel, 2001; Jung, 2003). This estimation brings into operation the self-monitoring function of a smart actuator.

The estimation of tool wear is useful to avoid tool breakages that often definitely damage the part. It may also be used to correct on line the tool path to take into account the changes of the tool geometry. Although this correction is not implemented at this stage of the study, we present a tool wear monitoring method that corresponds to the process monitoring function of a smart actuator. The proposed monitoring of the machining process is achieved from the estimation of the cutting forces. Indeed, the load torque l on a motor shaft is a function of the cutting force generated by the machining process. l can be estimated from the equation (2). Knowing l and the reduction ratios of the gears and of the ball screw and nut system, the cutting force component applied on the drive can be estimated. This estimation needs the measurements of i and w and the more recent estimated values for the parameters K , J , V and D (Stein and Shin, 1986; Stein *et al.*, 1986; Altintas, 1992). The force component estimation accuracy mainly depends on the accuracy of the estimated parameters whose values are supposed to be steady enough during a cutting operation. This can be considered as true for short cutting operations (few minutes) compared to the dynamic of the wear of the mechanical parts, of heating in the electromechanical structure. For example, the thermal time constant of 5 kW DC motor is about 1 hour whereas the wear of the mechanical parts, degradation of lubricating oil can take months to impact relevantly the values of the physical parameters. The cutting force depends on the cutting parameters (cutting speed, feed speed and depth of cut and, for milling operations, the number of cutting edges in the part) but also on the wear of the cutting edge(s) (Koren *et al.*, 1991; Ravindar *et al.*, 1993). Two models are therefore necessary:

- one model that put into relation the cutting force components and the cutting parameters,
- one model that put into relation the variation of cutting force components and wear under given cutting parameters.

To achieve the tool wear monitoring, the cutting parameters must be known. This is achieved by cooperation between the CSSA agents and the NC unit agent. The feed speed must be computed from the different speed measurements sent by the operative part to the CSSA axis agents. The cutting speed is

provided by CSSA spindle agent (knowing the tool diameter for milling and drilling processes) and from the position of the X-axis feed-drive (for turning process). The depth of cut requires a theoretical geometrical model of the raw part. This model is implemented in the NC unit agent. To compute the depth of cut the NC unit agent needs the positions of the axes. The tool wear is then estimated by each CSSA agent from the cutting force component it estimates, the depth of cut provided by the NC unit agent, the feed speed computed from the speeds of the axes and the cutting speed provided by the CSSA spindle agent and, for turning process, the position of the X-axis provided by CSSA X-axis agent.

The presented monitoring activities are mainly based on estimations using measurements of u , i and w for the feed drives and the spindle. Those measurements must be as accurate as possible. That is why each CSSA agent processes a validation treatment for the measured signals. The validation treatment is described in (Habbadi *et al.*, 1999). It is based on material and analytical redundancies involving the equation (1). So, it also exploits the most recent estimated physical parameters of the drive. The validation treatment also corrects the measurements and isolates faulty sensors. This method only requires the use of two current sensors and two tension sensors to correct the measurements of u , i and w . A faulty sensor event can be stored in the historical database of the CSSA agent and reported to the maintenance management system. This validation treatment corresponds to the self-diagnosis function of a smart sensor and contributes to improve the metrological quality of the measurements.

The CSSA agents and the NC unit agent according to the description given in section 4.2 achieve the function for accommodating to the cutting process and to machine state. The control system, made of CSSA agents and the NC unit agent, is aiming at working at the maximum metal removal speed, to increase productivity, within the following boundaries:

- under the maximum power or induced current that can be consumed by the motors (the cutting force is generally increasing as the tool is getting worn),
- within the limits of the cutting parameters (cutting speed and feed speed) given by the tool manufacturer abacus (the depth of cut depending on the raw part and the expected geometries and dimensions after the machining operation) and knowing that the surface roughness is also a function of the cutting speed and the feed speed.

However, the control system is also aiming at increasing the cutting tool life.

According to both those goals, the control system is modifying the cutting speed and/or the feed speed.

The events that lead to stop the machining process are:

- a detected worn tool,
- a drive fault detected from the estimated physical parameters,
- the inability to maintain the machining operation without exceeding the boundaries of the cutting parameters or without reaching the machine maximum capacity (maximum current or power of one of the motors).

According to the presented decisional entities, the system works with objectives that are not really opposed. Thus, the agents do not need to negotiate this is a research theme used in the field of multi-agent systems for the control real-time processes (Kraus *et al.*, 1995; Kraus, 1997). They just need to consult each other before making decision about the modification of the cutting speed and the feed speed.

For example, if one CSSA proposes to increase both feed speed and cutting speed and if another CSSA is already working at its maximum power, the speeds will not be increased and, at least one speed may be decreased according to the accommodating strategy.

The following section presents the developed platform that brings into operation the proposed control and monitoring framework.

5. Experimental platform and simulation results

The object-oriented approach is trend in the development of SSAs (Luttenbacher *et al.*, 1996). It is also highly used the field of multi-agent systems (Velasco *et al.*, 1996). This approach presents many advantages: it allows the definition of a system as a set of reusable objects; it enables the generalization/specialization and encapsulation principles (Blaha and Rumbaugh, 2005) and also satisfies expectations in terms of open controllers.

The platform, developed in C++, brings into operation the proposed control and monitoring framework. It drives a simulated operative part of a NC lathe for a simulated turning process with a tool which is getting worn. In the control and monitoring structure, we consider four agent entities:

- the NC unit agent (NCU),
- the CSSA X-axis feed-drive agent (CSSAX) and CSSA Z-axis feed-drive agent (CSSAZ),
- the CSSA spindle agent (CSSAS).

The Operative Part of the machine (OP) is an entity that simulates the machine behavior and the turning process.

The communication between the five entities is achieved thanks to Ethernet network and CORBA protocol, which provides facilities for the communication between distributed entities. CORBA is based on client/server approach. This offers a standard and open communication system (Meo, 2005). According to CORBA protocol, a client, which does not compute a method, sends data to a server. The server computes the method and sends the produced results to the client.

A method is a function which belongs to entities of a same class. To compute the requested method the server can become a client if the method it computes needs results of methods computed by other entities. The computational entities (agents and operative part) are distributed on computers that communicate thanks to an Ethernet network. The class diagram of the distributed entities is presented in figure 6. In this class diagram, the attributes and methods are not presented. The CSSA class does not have any instantiation.

5.1 Behavioral description of the experimental platform

In order to describe the behavior of the whole platform, we detail the behavior of entities of each instantiated class.

The NCU is beginning by reading, in a file, the speed and position references and a value that indicates if it is a motion in which there is a cutting operation or not. Then, it verifies if the machine can work (no worn tool detection, no spindle or feed drive fault). If there is a cutting operation, it verifies if the cutting speed and the feed speed are within the programmed boundaries. Eventually, it sends to the CSSAs on their requests the new references read in the file while the defined number of parts to machine is not reached. If the process must be stopped, the previous references are sent to the CSSAs. Therefore, the spindle keeps the same angular speed and the axis feed-drives stay at the same position.

The CSSAX, the CSSAZ and the CSSAS send to the OP the references they received from the NCU. Then, the OP requests them to process monitoring from the measurements of u , i and w it sends. The CSSAs process the received measurements by a low pass filter and stored the filtered and raw values. The CSSA then ask the NCU if there is a cutting operation or not.

If there is no cutting operation, the CSSAs estimate the physical parameters of their drives. Once the high-speed motion of the feed-drive or once the spindle start period is finished, the estimation algorithm stops. The estimated parameters are then compared to thresholds and if any of them are not within the

boundaries a variable that denotes diagnosed fault is sent to the NCU. This leads the NCU to stop the process.

If there is a cutting process, the CSSAs estimate their load torques l from equation (2). The magnitude of cutting force component f_e is estimated from l and from the position of the X-axis feed-drive and from the spindle speed. f_e is then compared to the theoretical magnitude f_t that is computed by the CSSAs from the cutting model, the feed speed, the position of the X-axis and Z-axis feed-drives and spindle speed. If a CSSA misses values to compute its estimation, it requests the appropriate CSSAs to provide them. The wear W is calculated thanks to the relationship (5).

$$W = \frac{f_e}{f_t} \quad (5)$$

The CSSAs compare the value of W to a programmed upper threshold and, if it is over this value, they request the NCU to stop the process. The process is stopped if at least two CSSAs detect that the tool is worn. During a motion involving cutting process, the CSSAs compare the power and current consumed by the motors to the maximum thresholds. If one of them is over its thresholds the concerned CSSA requests the other CSSAs to modify the cutting speed and/or the feed speed in order to reduce the cutting force otherwise it requests them to work at maximum metal removal speed. If every CSSA requests the other ones to work at maximum metal removal speed, the feed speed and cutting speed are modified according to the programmed strategy to decrease the time to machine a part and to increase the tool life (in number of parts). If not, the feed speed and cutting speed are modified to reduce the cutting force. The NCU supervises the modifications of those speeds in order to keep them within the programmed boundaries. The machining process is stopped if the speeds cannot be modified any more to keep on reducing the cutting force.

The OP simulates the behavior of the spindle and feed servo-drives, the cutting process and the tool wear process. The simulation is requested by the CSSAs when they send the speed and position references they may modify. When a step of simulation is achieved, the OP requires the monitoring method of the CSSAs. The models of the DC motor drives are presented in figures 7 and 8. Many parameters of the servo drives can be modified. Different cutting models and tool wear evolution laws can easily be implemented as well as other models of servo-drives.

The measurement validation process, which requires redundant current and tension sensors, is not implemented in the experimental platform. Indeed, it would not be very relevant because the signals are the results of a computation and so they are not perturbed.

5.2 Simulation results

We consider the turning operation described on figure 9. The raw part diameter is 402 mm; the final diameter is 400 mm; so the depth of cut is 1 mm. The length of the machined cylinder is 150 mm. We assume that the nominal feed speed is 5 mm/s and the nominal cutting speed is 10 m/s, which corresponds to 49.9 rad/s for the spindle speed. We assume that the cutting speed and feed speed may vary within an interval of more or less 20% around their nominal values. All the servo-drives have the same parameters. For the axis feed-drives, the maximum power is 6 kW and maximum current is 50 A whereas the maximum power is 12 kW and maximum current is 100 A for the spindle. The power and the current consumed by a servo-drive depend, for a constant load torque, on its physical parameters.

The considered models of the cutting process are empirical (Ravindar *et al.*, 1993). According to the notation of figure 9, the models are with $i = t, l$ or r :

$$F_i = K_i \cdot C_s^{p_i} \cdot F_s^{q_i} \cdot D_c^{r_i} \quad (6)$$

where C_s is the cutting speed, F_s is the feed speed, D_c the depth of cut and, F_i is the magnitude of the cutting force component, p_i , q_i and r_i are empirical coefficients and K_i is a coefficient that varies with wear. K_i is considered as a constant in the theoretical model processed by the CSSAs. We assume that:

$$\begin{aligned} p_i &= -0.1 \\ q_i &= r_i = 1 \\ K_t &= \xi \cdot E \\ K_l &= K_r = \gamma \cdot E \end{aligned} \quad (7)$$

W is a function of t_m the machining time and of C_s . The general pattern of the tool wear evolution is shown on figure 10. The calculus of the cutting force components from equation (6) multiplied by W generates the tool wear effect.

The programmed tool path is presented on figure 11. The only segment involved in metal cutting process is the bloc 5. We have considered a quite large tool clearance that may represent the necessary space to load the raw part and to unload the machined part. Blocs 1 and 2 describe the tool path after setting the part origin. The tool follows the segments of those blocs only once before starting the turning operation of the first part.

The CSSA estimate the physical parameters of the drive quickly and accurately, as shown on figures 12 and 13. The presented estimations were obtained by setting the estimator to the nominal values of the parameters, but the parameters of the drives were set at different values. Those values are presented in table 2. For the presented estimations as well as for the Z-axis, the convergence is carried out within 0.1 s without any bias. Indeed, there is no bias because the simulated model of the operative part is the same as the one implemented in the CSSAs and also because there is no noise on the measurements obtained by computation and transmitted numerically.

From the models computed by the different agents, which exchange their results, each CSSA achieves the estimation of tool wear. These estimations are quite accurate because there is no bias in the estimations of the physical parameters and because all the models (raw part model, cutting process model...) computed by the agents correspond exactly to the ones run by the OP. However, the relative error is about $1E-3$. The tool wear simulated in the OP without accommodating the cutting speed and feed speed is presented on figure 14. The errors of wear estimation for all the drives are presented on figure 15. The scale of figure 15 disables the distinction between the different errors of the estimations computed by the CSSAs. We notice that the sign and the magnitude of the relative errors change with the variation ratio of the wear. We therefore suppose that the error of estimation are mainly due to the delay to compute the estimation of W that also requires data exchanges between the objects, as described in the sections 4.3 and 5.1.

The simulations without any strategy for accommodating the feed speed and the cutting speed correspond to the standard functioning of a traditional NC lathe. Those simulations show that the machine and the tool achieve 7 parts. During the machining of the 8th part, the machine stops because the estimated value of the tool wear reaches the threshold. Let us note that we let the simulation run although the CSSAS detects that the maximum capacity of the spindle is exceeded during the machining of the 7th part. This last event should lead the NCU to stop the machining process earlier but we disable this function in order to have both results. The machine stops after 258.44 s of turning operation and the maximum capacity event occurs after 221.55 s for W estimated at 1.685.

The strategy for accommodating aims at reducing C_s in order to increase the tool life and at increasing F_s in order to increase the productivity. When a maximum capacity event is detected, the CSSAS increases C_s to keep the productivity at its maximum and while a maximum capacity event is detected. If C_s is at its maximum value and if a maximum capacity event is detected again, the CSSAX and CSSAZ decrease F_s in order to keep on machining parts. Thanks to this strategy, the simulations show that 8 parts are

completed before the NCU stops the machining operation of the 9th part because of a worn tool event detected after 257.38 s of turning operation whereas F_s is still reduced to tackle the maximum capacity of the spindle detected by the CSSAS.

The numerous values computed by the CSSAs achieve this strategy for accommodating to machine process (cutting force) and to the machine capacity (depending on the physical parameters of the servo-drives). This strategy enables to machine entirely 8 parts in 239.76 s of machine functioning. This must be compared to the 6 parts entirely machined without accommodating if the maximum capacity event was taken into account. The strategy enables to machine more parts with the same tool and to take less time to machine one part, which were the objectives of the study.

6. Conclusion

The proposed multi-agent framework for the control and monitoring of machine tools has been successfully implemented. The presented results show that the information produced at the additional decisional level by the smart sensors/actuators enable to bring into operation functions for monitoring, diagnosing and accommodating. Every piece of information is processed from current, speed, tension and position measurements that are already achieved in NC machine tools for the regulations. The only additional sensors would be current and tension sensors for processing measurements validation. The various functions share data. For example, the physical parameters are estimated for monitoring and for diagnosing the servo-drives, for estimating the cutting force and the tool wear and for validating the measurements. This avoids redundant data processes that may be encounter in the implementation of function-dedicated modules.

This alternative structure is modular and satisfies the expectations for reconfigurability. Indeed, it is developed in C++, there is one agent per drive, and Ethernet network with CORBA protocol offers a standard and open communication system. The simulations show that a non-application dedicated communication network like Ethernet can be sufficient for such applications. No problem of communication has disturbed the simulations.

The multi-agent integration platform is quite flexible because it enables to reconsider the physical processes and the control structure. Let us note that all the agents could be implemented in a same treatment unit but this could overload it and, perhaps, could not satisfy real-time constraints.

The information processed at the additional decision level can also be used for other purposes like maintenance, scheduling... The implementation of functions for monitoring and diagnosing the machine and the process as well as for accommodating contributes to increase productivity but also to increase the reliability and the reactivity.

Further developments of the presented multi-agent control and monitoring framework will deal with adapting the regulations to the states of feed-drives and of the spindle. Other developments will be undertaken in the definition of strategies for accommodating. Indeed, in the presented case study, the evolution of wear in time for given cutting parameters is a priori known, which is seldom. That is why a decision-making mechanism could be achieved in order to define the best strategy for accommodating. This process could be realized by negotiating agents. Another development consists in testing this alternative control and monitoring structure with a physical operative part driving a real metal cutting process.

Acknowledgements

The authors would like to thank the European Commission and the partners of the Innovative Production Machines and Systems (I*PROMS) Network of Excellence for their support.

References

- Altintas, Y., 1992. Prediction of cutting forces and tool breakage in milling from feed drive current measurements. *Journal of Engineering for Industry* 114, 387-392.
- Altintas, Y., Newell, N., Ito, M., 1996. Modular CNC design for intelligent machining, part 1: design of a hierarchical motion control module for CNC machine tools. *Journal of Manufacturing Science and Engineering* 118, 506-513.
- Blaha, M., Rumbaugh, J., 2005. *Object oriented modeling and Design with UML*, Ed. Prentice Hall.
- Carrillo, F.J., Rotella, F., 1997. A robust adaptive controller for constant turning force regulation. *Control Engineering Practice* 5 (12), 1673-1682.
- Dan, L., Mathew, J., 1990. Tool wear and failure monitoring techniques for turning - A review. *International Journal of Machine-Tools Manufacturing* 30 (4), 579-598.

- Desforges, X., Habbadi, A., 1997. A neural network for parameter estimation of a DC motor for feed-drives. Proceedings of the ICANN 1997, Lausanne, Switzerland, Lecture Notes in Computer Science n°1327, Springer, 867-872.
- Desforges, X., Habbadi, A., Geneste, L., Soler, F., 2004. Distributed machining control and monitoring using smart sensors/actuators. Journal of Intelligent Manufacturing 15 (1), 39-53.
- Habbadi, A., Desforges, X., Noyes, N., 1999. Data validation for a feed-drive monitoring: a case study. Proceedings of the IEEE international Symposium on Diagnostics for Electrical Machines, Power Electronics and Drives, Gijón, Spain, 131-136.
- Harris, C.G., Williams, J.H., Davies, A., 1989. Condition monitoring of machine-tools. International Journal of Production Research 27 (9), 1445-1464.
- Isermann, R., 1993. Fault diagnosis of machines via parameter estimation and knowledge processing - Tutorial paper. Automatica 29 (4), 815-835.
- Iung, B., 2003. From remote maintenance to MAS-based e-maintenance of an industrial process. Journal of Intelligent Manufacturing 14 (1), 59-82.
- Jennings, N.R., Wooldridge, M., 1995. Applying agent technology. Applied Artificial Intelligence 9 (4), 357-369.
- Kraus, S., Wilkenfeld, J., Zlotkin, G., 1995. Multiagent negotiation under time constraints. Artificial Intelligence 75 (2), 297-345.
- Kraus, S., 1997. Negotiation and cooperation in multi-agent environments. Artificial Intelligence 94, 79-97.
- Koren, Y., Ko, T.R., Ulsoy, A.G., Danai, K., 1991. Flank wear estimation under varying cutting conditions. Journal of Dynamic Systems, Measurement and Control 113, 303-307.
- Lee, D., Allan, J., Thompson, H.A., Bennett, S., 2001. PID control for distributed system with a smart actuator. Control Engineering Practice 9 (11), 1235-1244.
- Léger, J.B., Morel, G., 2001. Integration of maintenance in the enterprise: towards an enterprise modelling-based framework compliant with proactive maintenance strategy. Production Planning & Control 12 (2), 176-187.
- Liu, Y., Cheng, Heng, T., Zuo, L., 2001. Adaptive control constraint of machining process. International Journal of Advanced Manufacturing Technology 17, 720-726.

- Luttenbacher, D., Roth, S., Robert, M., 1996. Application of object-oriented technology to intelligent sensor development. *Journal of the International Measurement Confederation* 17 (3), 201-206.
- Meo, F., 2005. Open controller enabled by an advanced real-time network. *Proceedings of 1st I*PROMS (Intelligent Production Machines and Systems) Virtual International Conference, 4-15 July 2005*, Ed. Elsevier, 651-656.
- Molina, A., Rodriguez, C.A., Ahuett, H., Cortes, J.A., Ramirez, M., Jimenez, G., Martinez, S., 2005. Next-generation manufacturing systems: key research issues in developing and integrating reconfigurable and intelligent machines. *International Journal of Computer Integrated Manufacturing* 18 (7), 525-536.
- Mehrabi, M.G., Ulsoy, A.G., Koren, Y., Heytler, P., 2002. Trends and perspectives in flexible and reconfigurable manufacturing systems. *Journal of Intelligent Manufacturing* 13 (2), 135-146.
- Pritschow, G., Daniel, Ch., Junghans, G., Sperling, W., 1993. Open system controllers - A challenge for the future of the machine-tool industry. *Annals of the CIRP* 42 (1), 449-452.
- Ravindar, H.V., Sirinivasa, Y.G., Krishnamurthy, R., 1993. Modeling of tool wear based on cutting forces in turning. *Wear* 169 (1), 25-32.
- Renton, D., Elbestawi, M.A., 2000. High speed servo control of multi-axis machine tools. *International Journal of Machine Tools and Manufacture* 40 (4), 539-559.
- Robert, M., Rivière, J.M., Noizette, J.L., Hermann, F., 1993. Smart sensors in flexible manufacturing systems. *Sensors and Actuators A: Physical* 37-38, 239-246.
- Schofield, S., Wright, P., 1998. Open architecture controllers for machine tools, part 1: design principles. *Journal of Manufacturing Science and Engineering* 120, 417-424.
- Sente, P., Buyse, H., 1995. From smart sensors to smart actuators: application of digital encoders for position and speed measurements in numerical control systems. *Measurement* 15 (1), 25-32.
- Söderström, T., Fan, H., Carlsson, B., Bigi, S., 1997. Least squares parameter estimation of continuous-time ARX models from discrete time data. *IEEE Transactions on Automatic Control* 42 (5), 659-673.
- Stein, J.L., Colvin, D., Clever, G., Wang, C.H., 1986. Evaluation of DC servo machine-tool feed drives as force sensors. *Journal of Dynamic Systems, Measurement, and Control* 108, 279--288.
- Stein, J.L., Shin, K.C., 1986. Current monitoring of field controlled spindle drives. *Journal of Dynamic Systems, Measurement, and Control* 108, 289-295.

- Taner, A.H., White, N.M., 1996. Virtual instrumentation: a solution to the problem of design complexity in intelligent instruments. *Measurement and Control* 29, 165-171.
- Velasco, J.R., Gonzalez, J.C., Magdalena, L., Iglesias, C.A., 1996. Multiagent-based control systems: a hybrid approach to distributed process control. *Control Engineering Practice* 4 (6), 839-845.
- Xie, C., Pu, J.S., Moore, P.R., 1998. A case study on the development of intelligent actuator components for distributed control systems using LONWORK neuron chips. *Mechatronics* 8, 103-119.

Faults	Sensitive parameters
bearings and/or slide-ways wear	total dry friction torque D total viscous friction coefficient V
lack of lubricating oil and/or lubricating oil ageing	total dry friction torque D total viscous friction coefficient V
no work-piece and/or work-piece holder	moment of inertia J
brush wear	resistance R
motor heating	resistance R , inductance L , torque coefficient K
demagnetization	inductance L , torque coefficient K
...	...

Table 1. Relation between parameters and faults.

Parameter (unit)	nominal value	value set in the OPO
L (H)	4E-3	4E-3
R (Ω)	0.3	0.35
K (m.N.A ⁻¹)	0.6	0.55
J (kg.m ²)	0.116	0.12
V (m.N.s ⁻¹)	0.186	0.2
D (m.N)	0.5	0.4

Table 2. Nomimal values and values set in the OP of the physical parameters

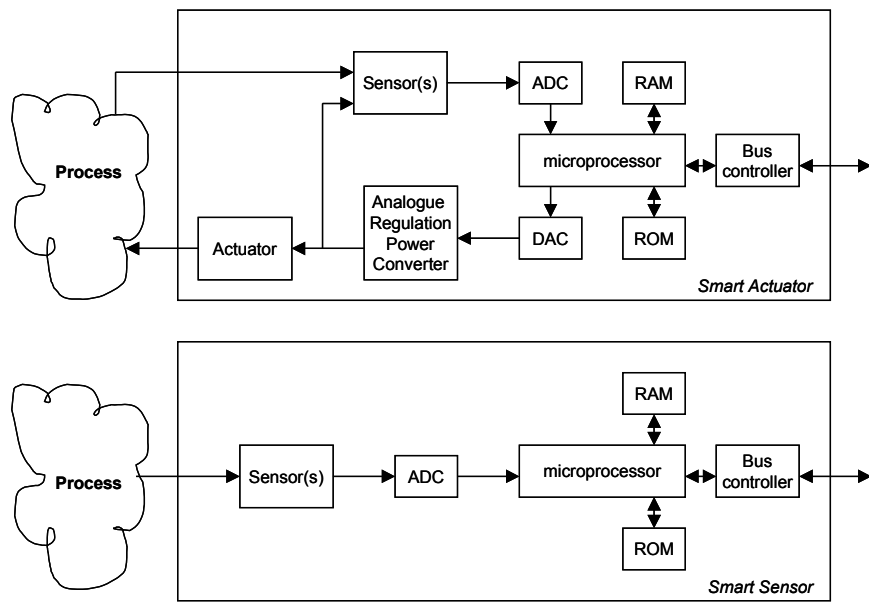

Figure 1. Physical structure of smart sensors and actuators

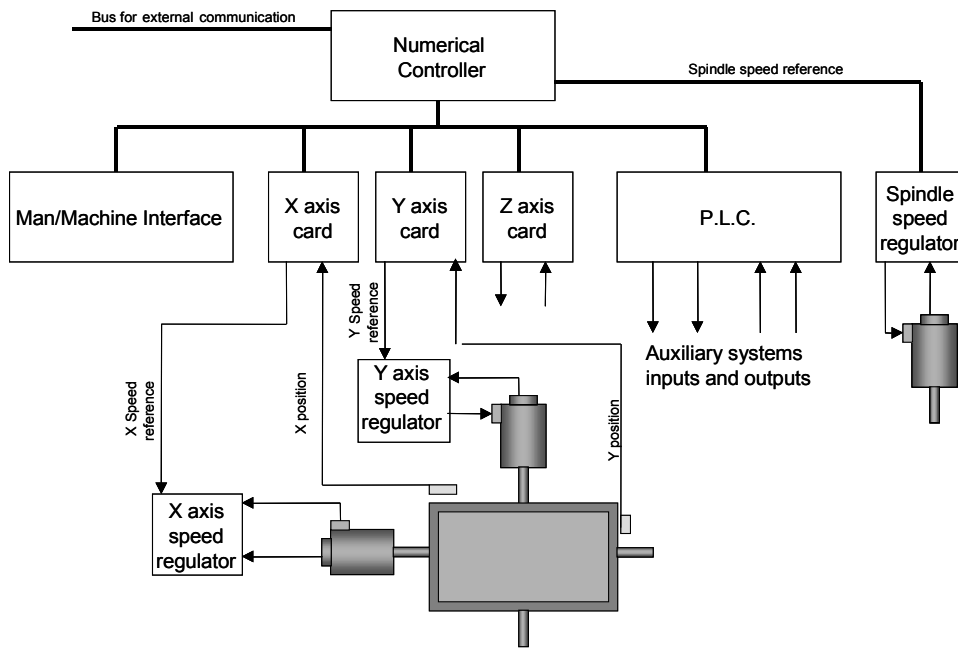

Figure 2. Control structure of a NC machine tool

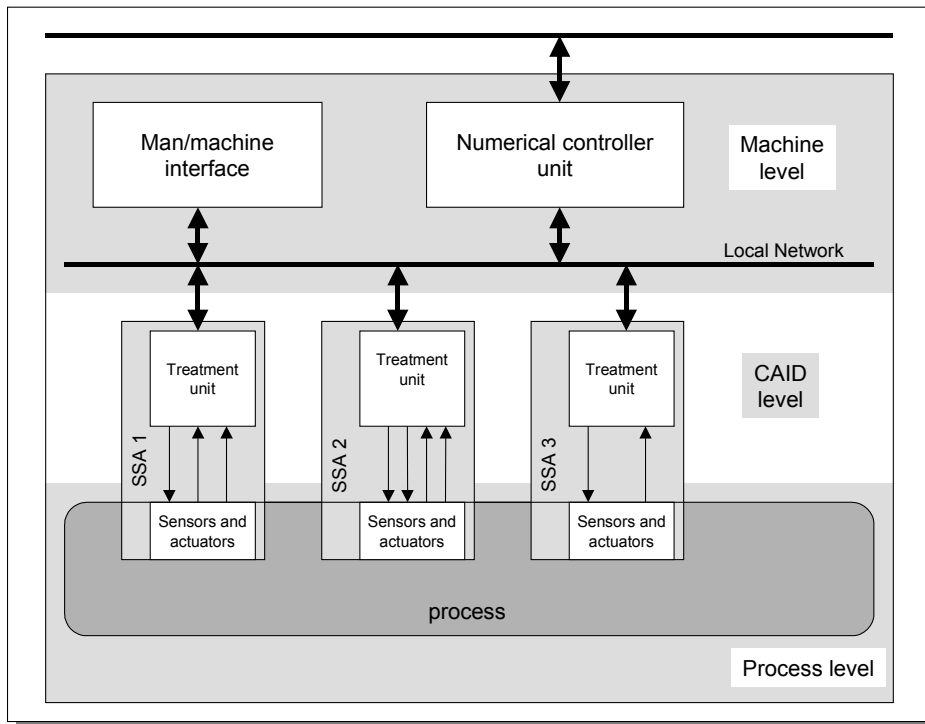

Figure 3. Physical structure of a machine involving physical smart sensors/actuators

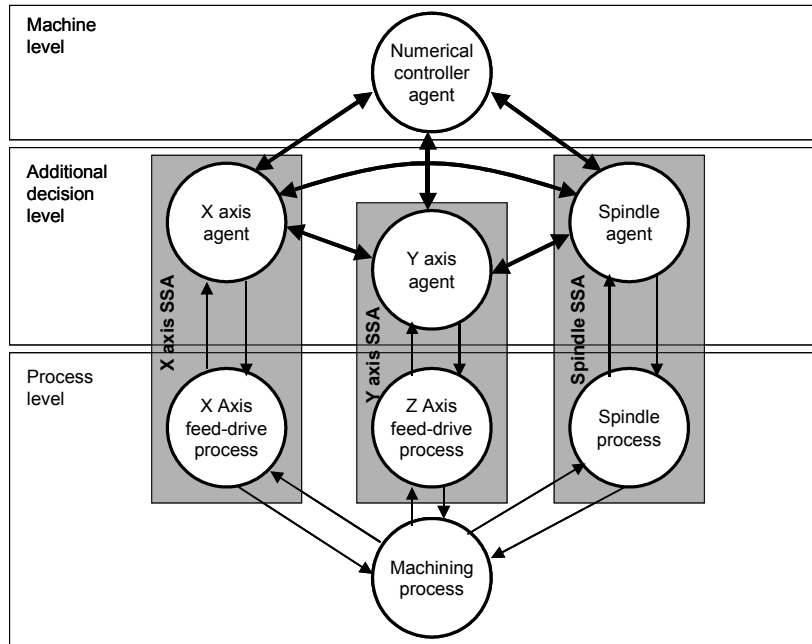

Figure 4. Place of the additional decision level in the structure

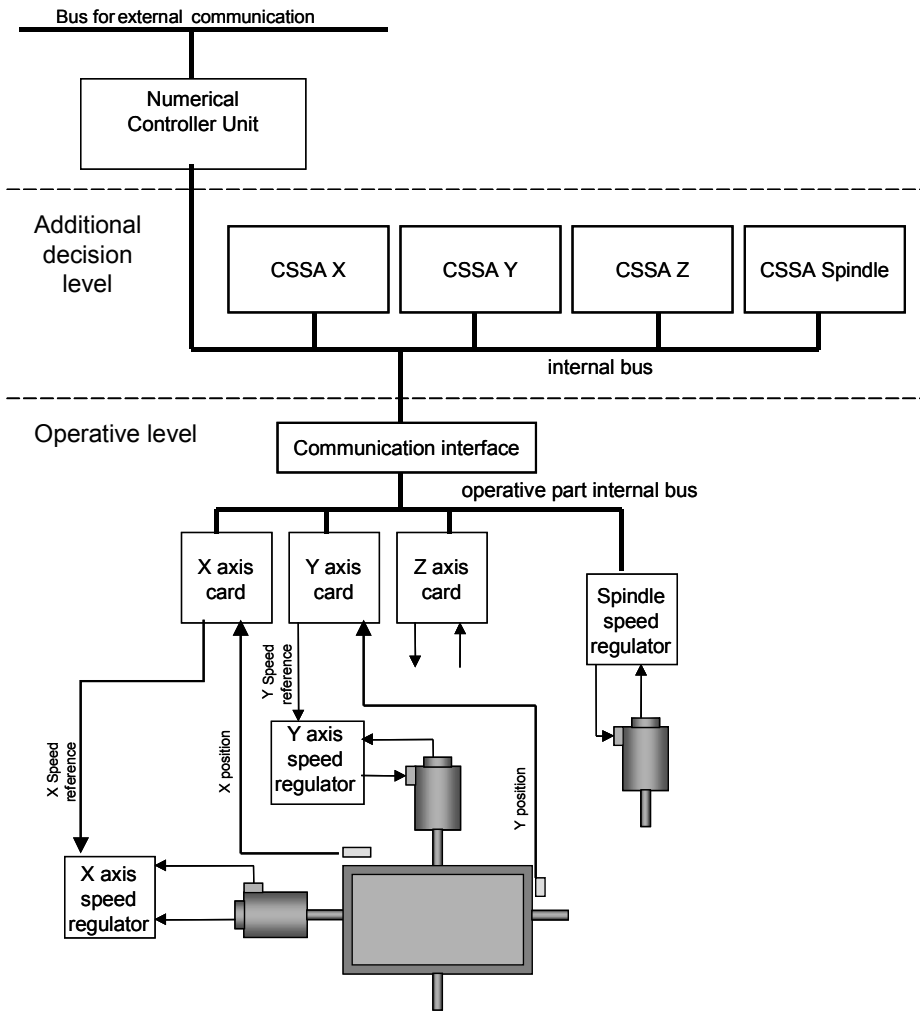

Figure 5. Proposed framework for the integration of an additional decision level

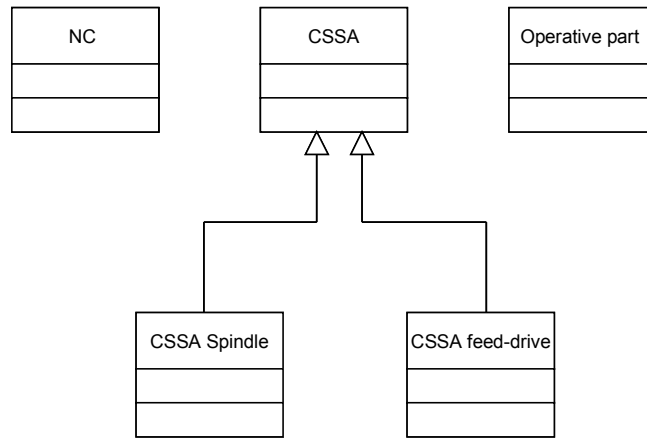

Figure 6. Class diagram of the platform

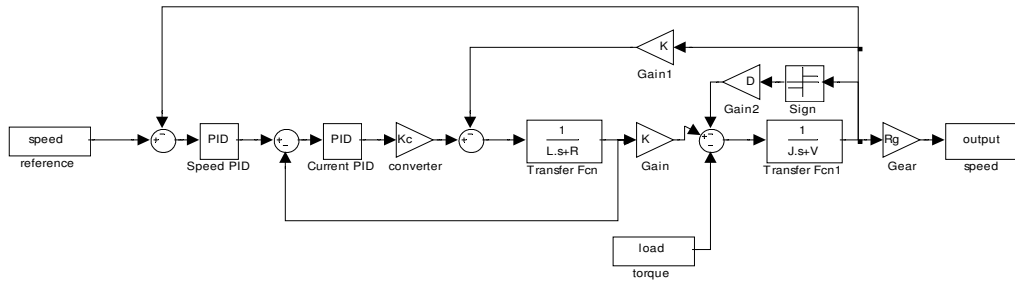

Figure 7. Spindle model

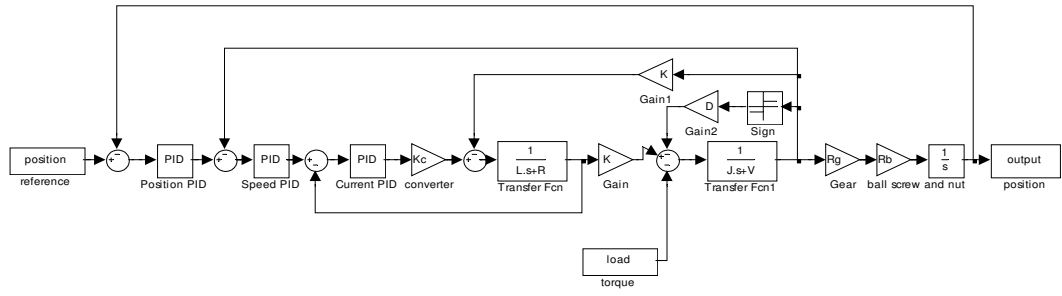

Figure 8. Feed-drive model

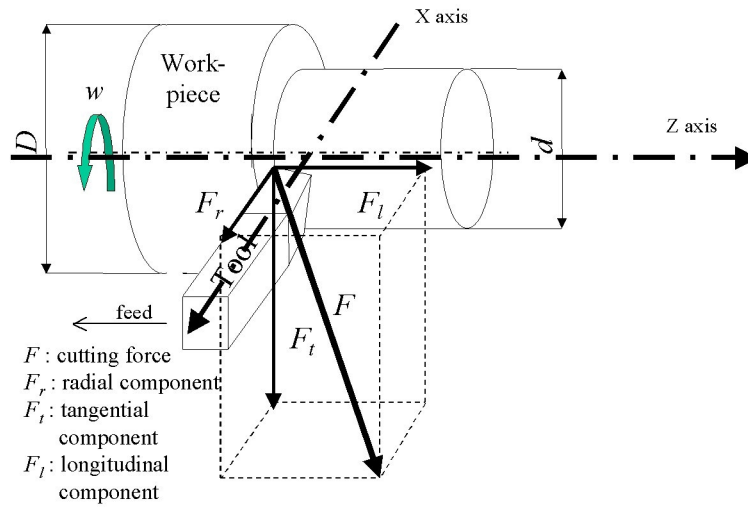

Figure 9. turning process considered in simulations

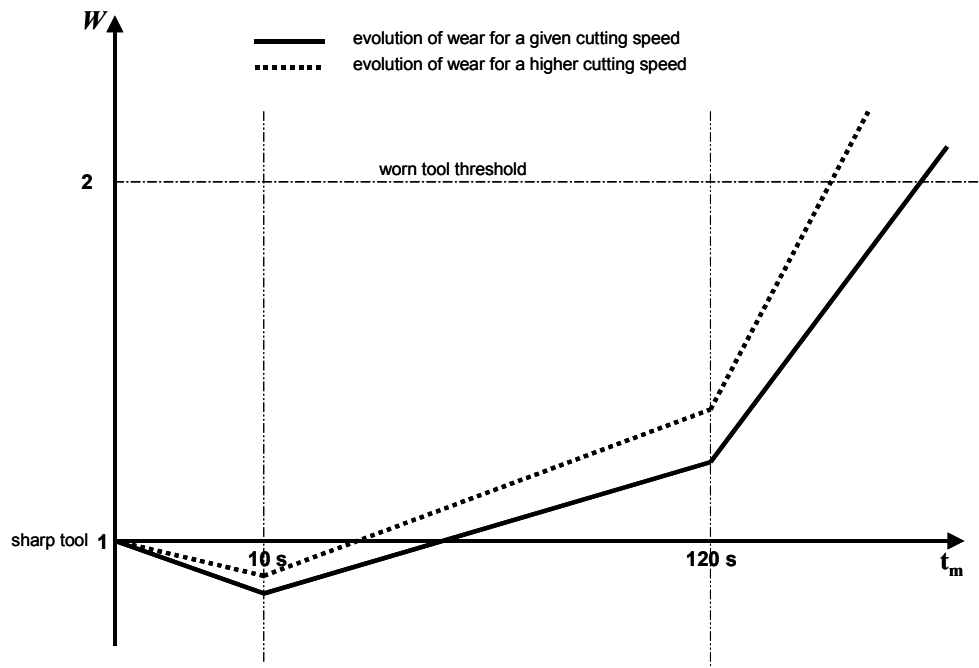

Figure 10. Patterns of tool wear evolution

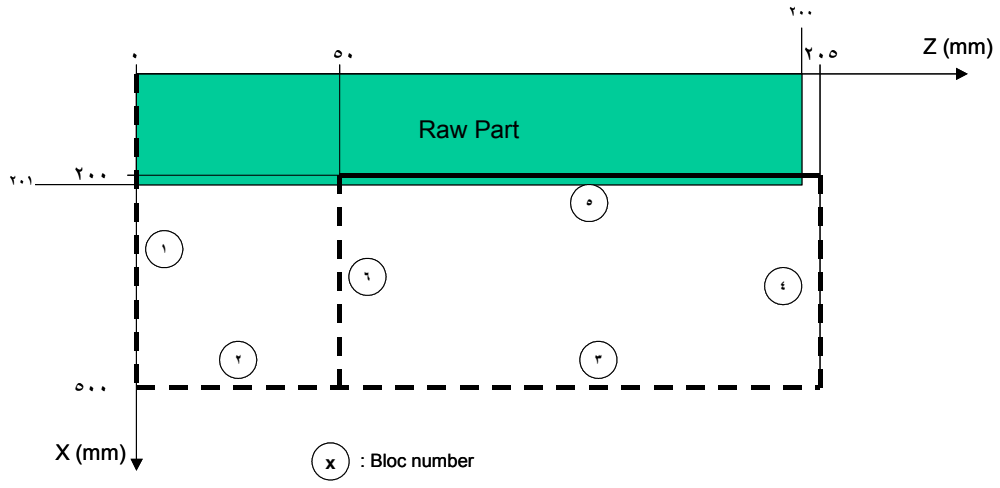

Figure 11. Diagram of the programmed tool path

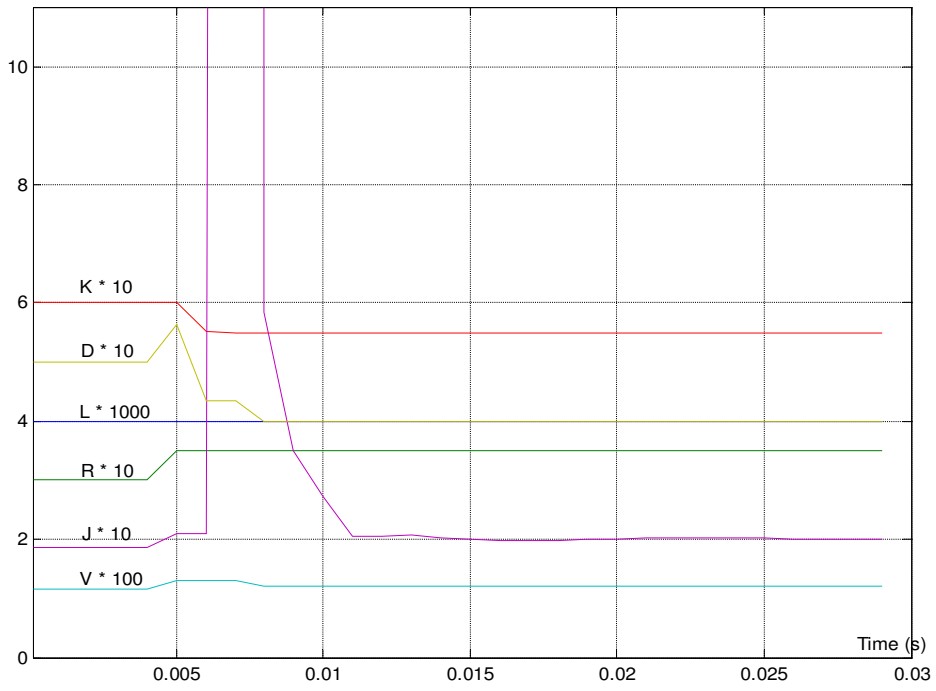

Figure 12. Estimation of the spindle parameters

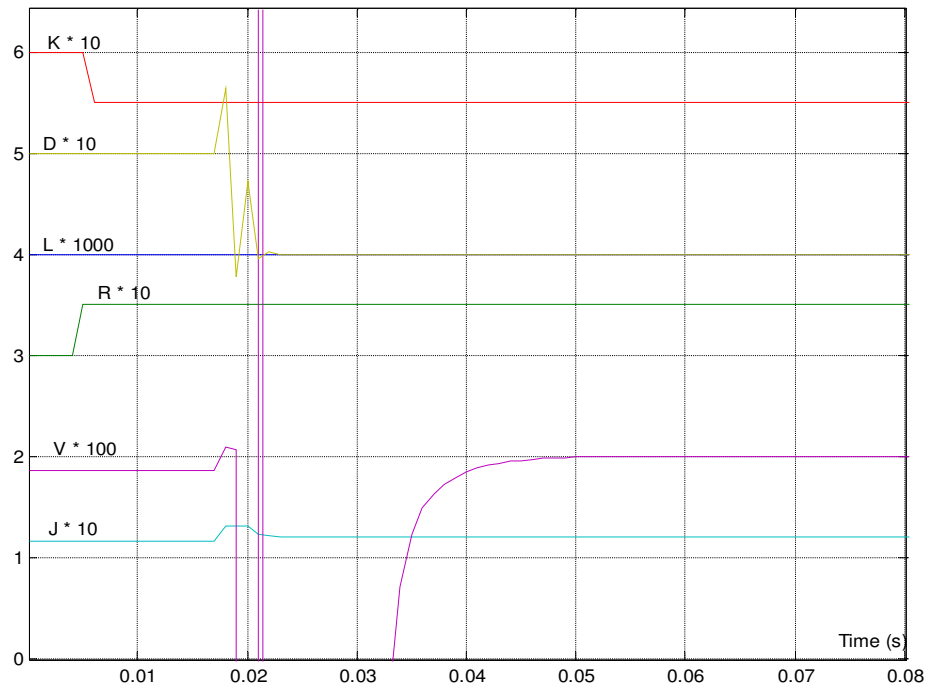

Figure 13. Estimation of the X-axis feed-drive parameters

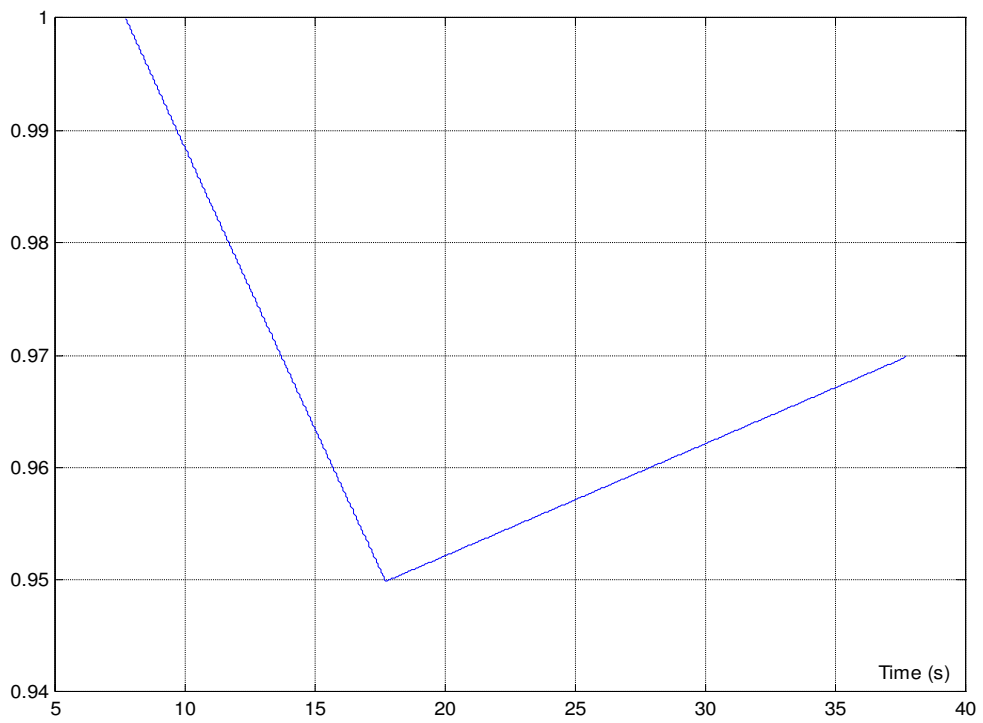

Figure 14. Wear pattern simulates by the OP for the first part without accommodating

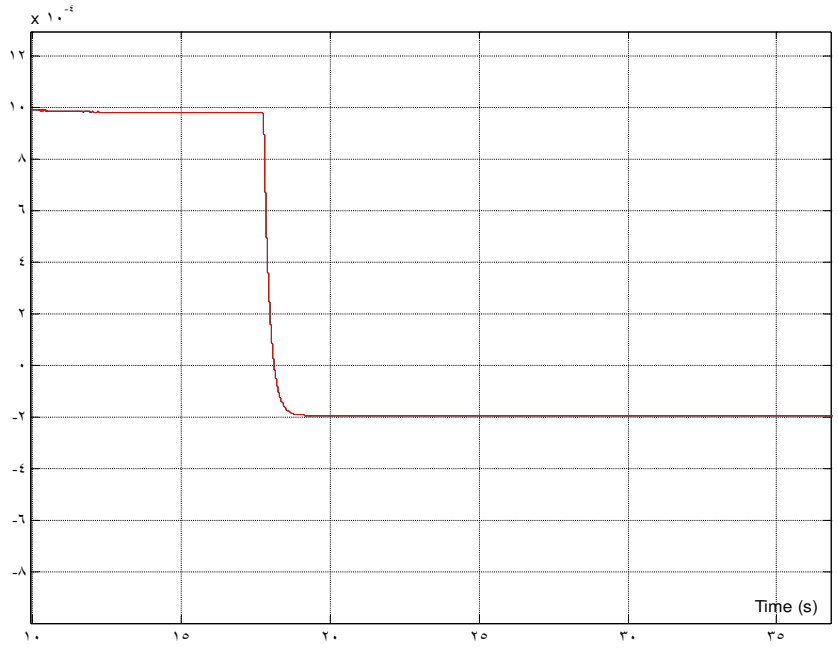

Figure 15. Tool wear estimation errors