



HAL
open science

Linear-quadratic Stackelberg differential game: local information versus global information

Xinwei Feng, Ying Hu, Jianhui Huang

► **To cite this version:**

Xinwei Feng, Ying Hu, Jianhui Huang. Linear-quadratic Stackelberg differential game: local information versus global information. *ESAIM: Control, Optimisation and Calculus of Variations*, 2024, 30 (Paper No. 47), 41 pp. 10.1051/cocv/2024037 . hal-03812039

HAL Id: hal-03812039

<https://hal.science/hal-03812039v1>

Submitted on 12 Oct 2022

HAL is a multi-disciplinary open access archive for the deposit and dissemination of scientific research documents, whether they are published or not. The documents may come from teaching and research institutions in France or abroad, or from public or private research centers.

L'archive ouverte pluridisciplinaire **HAL**, est destinée au dépôt et à la diffusion de documents scientifiques de niveau recherche, publiés ou non, émanant des établissements d'enseignement et de recherche français ou étrangers, des laboratoires publics ou privés.

Linear-quadratic Stackelberg differential game: local information versus global information

Xinwei Feng · Ying Hu · Jianhui Huang

Received: date / Accepted: date

Abstract We first present a unified framework to fit a variety of two-person differential decision problems, including especially stochastic (zero-sum, non zero-sum) Nash game, Stackelberg game with global information. Next, solvability of these problems are also discussed via three forms respectively: an abstract quadratic functional representation, Hamiltonian system for open-loop, and Riccati equation for closed-loop (feedback). Then, we introduce a new type Stackelberg game with local information for which the classical best-response machinery used for global information is no longer workable. As resolution, a repeated game approach is employed to construct the equilibrium strategies via a backward- and forward-procedure. Moreover, connection of local information pattern to time-inconsistency is also revealed. Finally, relations among zero-sum Nash game, zero-sum Stackelberg game with global information and local information are identified.

Keywords Nash game, Stackelberg game, Global information, Local information, Repeated game, Backward-forward procedure.

1 Introduction

Our starting point is the well-studied two-person dynamic decisions, including such as *team* with cooperation but based on asymmetric information structures, or *game* with non-cooperation and competitive functionals. As for game, it can be further specified as Nash game with synchronous decision, or leader-follower game with asynchronous decisions or moves. On the other hand, the game can also be featured as zero-sum or non zero-sum depending on the competitiveness of underlying functionals. All above game/team problems arise naturally in various fields such as engineering, economy, biology and operational research, etc. Thus, they are all well-motivated

Xinwei Feng
Zhongtai Securities Institute for Financial Studies, Shandong University, Jinan, Shandong 250100, China.
E-mail: xwfeng@sdu.edu.cn

Ying Hu
IRMAR, Université Rennes 1, Campus de Beaulieu, 35042 Rennes Cedex, France and School of Mathematical Sciences, Fudan University, Shanghai 200433, China
E-mail: ying.hu@univ-rennes1.fr

Jianhui Huang
Department of Applied Mathematics, The Hong Kong Polytechnic University, Hong Kong.
E-mail: majhuang@polyu.edu.hk

with solid backgrounds in both theoretical and practical aspects.

Among them, one extensively-studied differential decision is the noncooperative Nash games, where the player aims to minimize his/her own cost functional and searches the solution of non-cooperative games known conceptually as Nash equilibrium. A set of strategies taken by the players is a Nash equilibrium, if each player knows the equilibrium strategies of the other players and no player intends to unilaterally change his/her own strategy. In other words, if no player can benefit by changing his/her strategy while the other player keep his/her strategy unchanged, then the current set of strategies constitutes a Nash equilibrium. Therefore, finding the Nash equilibrium of a noncooperative game is not generally equivalent to a single optimization problem, but is rather a family of coupled optimization problems. Sometimes the goals of the players could be completely opposite, for example, in a gambling of two players the gain of one player is the loss of the other one. In this case the game is called two-person zero-sum differential games and the Nash equilibrium becomes a saddle point.

This paper focuses on differential game in linear-quadratic (LQ) context. Recall LQ differential games with linear state equation and quadratic functional, has always been one important branch of differential games and played an essential role in the study of general differential games. For such kind of differential games, the open-loop and closed-loop solutions can be explicitly formulated and then differently treated. The study of two-person LQ decision problem has been extensively investigated and there accumulates vast literature around it with various setups. Here we mention a few more relevant to current work. For stochastic LQ differential games, Mou and Yong [16] obtained the existence of the open-loop saddle points by means of the Hilbert space method. Sun and Yong [21] established the characterizations and relationships of open-loop and closed-loop saddle points for stochastic LQ differential games. Sun and Yong [22] further explored stochastic LQ two-person nonzero-sum differential games. Applying the method of Riccati equation, Yu [28] obtained the optimal feedback and control-strategy pair. Please refer to [9,10] for other works on LQ differential games.

For nonlinear two-person zero-sum differential games, Fleming and Souganidis [8] showed that the lower and the upper value functions satisfy the dynamic programming principle and are the unique viscosity solutions of the associated Bellman-Isaacs equations. Then the uniqueness of viscosity solutions together with the Isaacs condition leads to the existence of the value function for the differential game. Please see [5,6] and the reference for more details.

Stackelberg game with global information

In aforementioned literature, the roles of two players can be reversed and assume a rather symmetric pattern. In fact, there does not admit hierarchy for two players when making decisions so decisions are synchronous. Stackelberg game, also known as leader-follower game, can be traced back to the early work by Stackelberg [19]. Actually, it is a strategic game with at least two non-symmetric hierarchies. One hierarchy is the leader and the other one is the follower. The leader has the priority to announce a strategy at first and then the follower seeks a strategy to minimize his/her cost functional with response to the leader's strategy. Finally the leader improves his/her strategy to minimize his/her own cost functional with respect to the follower's response. The optimal strategies of the leader and the follower form a Stackelberg equilibrium. By *global information*, we mean the leader will make his commitment over the whole decision horizon at the beginning thus the follower may anticipate the action of leader with global foreknowledge. As a result, Stackelberg game can be decomposed into two iterative optimization problems in standpoints of follower and leader sequentially.

Stackelberg differential game has practical financial and economical backgrounds and has been extensively studied in recent years. Başar and Olsder [1], Long [13] studied the determinis-

tic Stackelberg game. Yong [26] studied an LQ leader-follower differential game in a more general framework with random coefficients, control variables entering the diffusion and the weight matrices in cost functionals being not necessarily positive definite. Lin, Jiang and Zhang [12] studied the open-loop LQ Stackelberg game of the mean-field stochastic systems in finite horizon. Wang and Zhang [24] studied the Stackelberg differential game with one leader and N followers in discrete-time model and the model under continuous-time framework was studied in Moon and Başar [15]. The stochastic Stackelberg differential game with time-delayed information was studied in Øksendal, Sandal and Ubøe [17]. Shi, Wang and Xiong [20] considered a leader-follower stochastic differential game with asymmetric information. Bensoussan, Chen, Chutani and Sethi [2] studied the feedback equilibrium of a general infinite-horizon Stackelberg-Nash differential game where the roles of the players are mixed. Please see [7, 14, 18] for the related applications.

Stackelberg game with local information

In the aforementioned Stackelberg games, the leader will announce his strategy on the whole time horizon at the initial time, we call this kind of games Stackelberg game with global information. However in many real problems, the local information pattern, instead of the above global information pattern will be applied. For example, the product plan of a company depends on the government's policy while the government (acts as leader) will announce the policy quarterly in a year. More precisely, let $0 = s_0 < s_1 < s_2 < \dots < s_N = T$ be a division of $[0, T]$, the leader will announce his strategy on $\mathcal{S}_i \triangleq [s_{i-1}, s_i]$ at s_{i-1} , $i = 1, \dots, N$. Note that for Stackelberg game with local information, the main technique difficulties are that the best response approach doesn't work anymore. Instead, we will introduce a new repeated game approach to finite time horizon Stackelberg game with local information and finally solve the game by backward-forward procedure.

Repeated game approach

Let us now briefly explain the procedure of finding the equilibrium strategies for Stackelberg game with local information. For local information pattern, we will attempt to seek local optimal strategies, instead of global optimal strategies. At a conceptual level, the idea is that we will seek the equilibrium strategies, or optimal strategies on every time intervals. Motivated by the repeated game, we first study the Stackelberg game backwardly (backward induction). On \mathcal{S}_N , the follower will first solve a LQ problem and the leader then solves a forward backward linear quadratic (FBLQ) problem. Next, after obtaining the optimal costs and strategies on $[s_{N-1}, s_N]$, the follower and leader then solve a Stackelberg game on \mathcal{S}_{N-1} . By this backward induction, the optimal costs and strategies of the leader and the follower are obtained on \mathcal{S}_i , $i = 1, \dots, N$. Note that on \mathcal{S}_i , $i = 2, \dots, N$, the initial states $x(s_{i-1})$ are unknown while the optimal costs and strategies obtained by the backward induction depend on these unknown initial states. Hence the backward induction is not enough to fully solve Stackelberg game with local information. However, on \mathcal{S}_1 , the initial state $x(s_0)$ is fixed and the Stackelberg game will be fully solved if the form of the cost functionals on \mathcal{S}_1 is specified (which has already been determined by the backward induction). Therefore, applying the form of cost functional obtained by the backward induction on every time interval, we will finally study the Stackelberg game on \mathcal{S}_i , $i = 1, \dots, N$ forwardly to find the equilibrium strategies of the leader and follower. More details are given in the following sections.

To summarize the above, we see that the novelty of the formulation in this paper is the following: (i) We give a unified framework to connect and study stochastic (zero-sum, non zero-sum) Nash game, Stackelberg game with global- and local information. (ii) A new repeated game approach combined with backward-forward procedure are applied to study Stackelberg game with local information. (iii) The state feedback representations of equilibrium strategies to such differential game are obtained via a sequence of stochastic Riccati equations. The wellposedness of related Riccati equations for some special but nontrivial case is established.

The rest of the paper is organized as follows. In Section 2, we establish a unified two-person differential decision setup. In Section 3, we solve stochastic (zero-sum, non zero-sum) Nash game and Stackelberg game with global information by the quadratic functional representation, Hamiltonian system representation and Riccati equation representation, respectively. We introduce the concept of Stackelberg duration index and study Stackelberg game with local information via repeated game approach combined with backward-forward procedure in Section 4. A special but nontrivial case is also studied where the wellposedness of the involved stochastic Riccati equations are obtained. We obtain the relationship among (NG_0) , (SG_0) and (SL_0) in Section 5.

2 Two-person differential decision problems

2.1 Preliminaries

Let $(\Omega, \mathcal{F}, \mathbb{F}, \mathbb{P})$ be a complete filtered probability space on which a standard one-dimensional Brownian motion $W = \{W(t), 0 \leq t < \infty\}$ is defined, where $\mathbb{F} = \{\mathcal{F}_t\}_{t \geq 0}$ is the natural filtration of $W(\cdot)$ augmented by all the \mathbb{P} -null sets in \mathcal{F} . The following notations will be used throughout the paper. Let \mathbb{R}^n denote the n -dimensional Euclidean space with standard Euclidean norm $|\cdot|$ and standard Euclidean inner product $\langle \cdot, \cdot \rangle$. The transpose of a vector (or matrix) x is denoted by x^\top . $\text{Tr}(A)$ denotes the trace of a square matrix A . Let $\mathbb{R}^{n \times m}$ be the Hilbert space consisting of all $(n \times m)$ -matrices with the inner product $\langle A, B \rangle \triangleq \text{Tr}(AB^\top)$ and the norm $\|A\| \triangleq \langle A, A \rangle^{\frac{1}{2}}$. Denote the set of symmetric $n \times n$ matrices with real elements by \mathbb{S}^n and $n \times n$ identity matrices by I_n . If $M \in \mathbb{S}^n$ is positive (semi-)definite, we write $M > (\geq) 0$. If there exists a constant $\delta > 0$ such that $M \geq \delta I$, we write $M \gg 0$.

Consider a finite decision horizon $[0, T]$ for a fixed $T > 0$. The set of H -valued continuous functions is denoted by $C([0, T]; H)$. If $N(\cdot) \in C([0, T]; \mathbb{S}^n)$ and $N(t) > (\geq) 0$ for every $t \in [0, T]$, we say that $N(\cdot)$ is positive (semi-)definite, which is denoted by $N(\cdot) > (\geq) 0$. For any $t \in [0, T]$ and Euclidean space \mathbb{H} , introduce the following spaces

$$L_{\mathcal{F}_t}^2(\Omega; \mathbb{H}) = \{\xi : \Omega \rightarrow \mathbb{H} \mid \xi \text{ is } \mathcal{F}_t\text{-measurable, } \mathbb{E}|\xi|^2 < \infty\},$$

$$L_{\mathcal{F}_t}^\infty(\Omega; \mathbb{H}) = \{\xi : \Omega \rightarrow \mathbb{H} \mid \xi \text{ is } \mathcal{F}_t\text{-measurable, } \text{esssup}_{\omega \in \Omega} |\xi(\omega)| < \infty\},$$

$$L_{\mathbb{F}}^2(t, T; \mathbb{H}) = \left\{ \phi : [t, T] \times \Omega \rightarrow \mathbb{H} \mid \phi \text{ is } \mathbb{F}\text{-progressively measurable, } \mathbb{E} \int_0^T |\phi(s)|^2 ds < \infty \right\},$$

$$L_{\mathbb{F}}^\infty(t, T; \mathbb{H}) = \left\{ \phi : [t, T] \times \Omega \rightarrow \mathbb{H} \mid \phi \text{ is } \mathbb{F}\text{-progressively measurable, } \text{esssup}_{s \in [t, T]} \text{esssup}_{\omega \in \Omega} |\phi(s)| < \infty \right\},$$

$$L_{\mathbb{F}}^2(\Omega; C([t, T]; \mathbb{H})) = \left\{ \phi : [t, T] \times \Omega \rightarrow \mathbb{H} \mid \phi \text{ is } \mathbb{F}\text{-adapted, continuous, } \mathbb{E} \left[\sup_{s \in [t, T]} |\phi(s)|^2 \right] < \infty \right\}.$$

If the processes are deterministic, the corresponding spaces are denoted by $L^2(\Omega; \mathbb{H})$, $L^\infty(\Omega; \mathbb{H})$, $L^2(t, T; \mathbb{H})$ and $L^\infty(t, T; \mathbb{H})$, respectively.

2.2 A unified two-person decision setup

Consider the following unified setup with two-person decision problem. The state is given by controlled linear stochastic differential equation (SDE) on a finite time horizon $[t, T]$:

$$\begin{cases} dx(s) = [A(s)x(s) + B_1(s)u(s) + B_2(s)v(s)] ds + [C(s)x(s) + D_1(s)u(s) + D_2(s)v(s)] dW(s), \\ x(t) = \xi \in \mathbb{R}^n, \end{cases} \quad (1)$$

where $A(\cdot), B_1(\cdot), B_2(\cdot), C(\cdot), D_1(\cdot), D_2(\cdot)$ are deterministic functions on $[t, T]$ of proper dimensions. Now, define the following two-person admissible decision sets as:

$$\begin{aligned} \mathcal{U}([t, T]) &\triangleq \left\{ u : [t, T] \times \Omega \rightarrow \mathbb{R}^{m_1} \mid u(\cdot) \text{ is } \mathbb{F}\text{-progressively measurable, } \mathbb{E} \int_t^T |u(s)|^2 ds < \infty \right\}, \\ \mathcal{V}([t, T]) &\triangleq \left\{ v : [t, T] \times \Omega \rightarrow \mathbb{R}^{m_2} \mid v(\cdot) \text{ is } \mathbb{F}\text{-progressively measurable, } \mathbb{E} \int_t^T |v(s)|^2 ds < \infty \right\}. \end{aligned}$$

To measure the performance of decisions $u(\cdot)$ and $v(\cdot)$, we introduce the following cost functionals:

$$\left\{ \begin{aligned} J(t, \xi; u(\cdot), v(\cdot)) &\triangleq \mathbb{E} \left\{ \int_t^T \left[\langle Q_1(s)x(s), x(s) \rangle + \langle R_{J,1}(s)u(s), u(s) \rangle + \langle R_{J,2}(s)v(s), v(s) \rangle \right] ds \right. \\ &\quad \left. + \langle G_1x(T), x(T) \rangle \right\}, \\ K(t, \xi; u(\cdot), v(\cdot)) &\triangleq \mathbb{E} \left\{ \int_t^T \left[\langle Q_2(s)x(s), x(s) \rangle + \langle R_{K,1}(s)u(s), u(s) \rangle + \langle R_{K,2}(s)v(s), v(s) \rangle \right] ds \right. \\ &\quad \left. + \langle G_2x(T), x(T) \rangle \right\}. \end{aligned} \right. \quad (2)$$

We give the following assumptions on the coefficients:

- (H1) $A(\cdot), C(\cdot) \in L^\infty(t, T; \mathbb{R}^{n \times n}), B_1(\cdot), D_1(\cdot) \in L^\infty(t, T; \mathbb{R}^{n \times m_1}), B_2(\cdot), D_2(\cdot) \in L^\infty(t, T; \mathbb{R}^{n \times m_2})$.
(H2) $Q_1(\cdot), Q_2(\cdot) \in L^\infty(t, T; \mathbb{S}^n), R_{J,1}(\cdot), R_{K,1}(\cdot) \in L^\infty(t, T; \mathbb{S}^{m_1}), R_{J,2}(\cdot), R_{K,2}(\cdot) \in L^\infty(t, T; \mathbb{S}^{m_2}), G_1, G_2 \in \mathbb{S}^n$.

For any $u(\cdot) \in \mathcal{U}([t, T])$ and $v(\cdot) \in \mathcal{V}([t, T])$, it is well known that under (H1) the state (1) admits a unique strong solution, and under (H2) the cost functionals are well-defined. To simplify the presentations, in the following we will suppress the time variables (s) and (\cdot) . Given state (1) and cost functionals (2), we can formulate various decision problems. The first one is nonzero-sum stochastic differential game (NG) whose solvability is based on the following *Nash equilibrium*:

$$(\mathbf{NG}) : \left\{ \begin{aligned} &\text{To find } (\bar{u}(\cdot), \bar{v}(\cdot)) \in \mathcal{U}([t, T]) \times \mathcal{V}([t, T]), \text{ such that:} \\ &J(t, \xi; \bar{u}(\cdot), \bar{v}(\cdot)) \leq J(t, \xi; u(\cdot), \bar{v}(\cdot)), \quad K(t, \xi; \bar{u}(\cdot), \bar{v}(\cdot)) \leq K(t, \xi; \bar{u}(\cdot), v(\cdot)), \\ &\text{where } (t, \xi) \in [0, T] \times \mathbb{R}^n, (u(\cdot), v(\cdot)) \in \mathcal{U}([t, T]) \times \mathcal{V}([t, T]), \\ &\text{subject to } J(t, \xi; u(\cdot), v(\cdot)) + K(t, \xi; u(\cdot), v(\cdot)) \neq 0. \end{aligned} \right.$$

A special case of (NG) is zero-sum stochastic differential game (NG₀) for which the Nash equilibrium becomes a saddle point (SP):

$$(\mathbf{NG}_0) : \left\{ \begin{aligned} &\text{To find } (\bar{u}(\cdot), \bar{v}(\cdot)) \in \mathcal{U}([t, T]) \times \mathcal{V}([t, T]), \text{ such that:} \\ &J(t, \xi; \bar{u}(\cdot), v(\cdot)) \leq J(t, \xi; \bar{u}(\cdot), \bar{v}(\cdot)) \leq J(t, \xi; u(\cdot), \bar{v}(\cdot)), \\ &\text{where } (t, \xi) \in [0, T] \times \mathbb{R}^n, (u(\cdot), v(\cdot)) \in \mathcal{U}([t, T]) \times \mathcal{V}([t, T]). \end{aligned} \right.$$

In above two problems, there is no hierarchy for the players, i.e., the roles of two players are symmetric when making the decisions. For players with hierarchical decisions (e.g., Player 1 is the follower \mathcal{A}_F and Player 2 is the leader \mathcal{A}_L), the leader \mathcal{A}_L will first announce his/her open-loop dynamic decision on $[t, T]$ at the initial time t by taking account the best response of follower. Then, two interrelated optimization problems are sequentially solved by the follower \mathcal{A}_F and

the leader \mathcal{A}_L . More rigorously, we introduce Stackelberg game with *global* information (SG) as follows:

$$(SG) : \begin{cases} \text{To find } \bar{\alpha} : \mathcal{V}([t, T]) \times \mathbb{R}^n \rightarrow \mathcal{U}([t, T]), \bar{v}(\cdot) \in \mathcal{V}([t, T]), \text{ such that:} \\ J(t, \xi; \bar{\alpha}[v(\cdot), \xi](\cdot), v(\cdot)) \leq J(t, \xi; u(\cdot), v(\cdot)), & \text{(best response)} \\ K(t, \xi; \bar{\alpha}[\bar{v}(\cdot), \xi](\cdot), \bar{v}(\cdot)) \leq K(t, \xi; \bar{\alpha}[v(\cdot), \xi](\cdot), v(\cdot)), & \text{(iterative optimization)} \\ \text{where } (t, \xi) \in [0, T] \times \mathbb{R}^n, (u(\cdot), v(\cdot)) \in \mathcal{U}([t, T]) \times \mathcal{V}([t, T]). \end{cases}$$

(SG) above is denoted as *global information* because the leader's strategy $v(\cdot)$ is announced on whole decision horizon $[t, T]$ at time spot t . For the special case $J(t, \xi; u(\cdot), v(\cdot)) + K(t, \xi; u(\cdot), v(\cdot)) = 0$, we denote above Stackelberg game by (SG₀).

2.3 Quadratic representation of cost functionals

In order to study the solvability, it is helpful to introduce the following quadratic representations of cost functionals first. Then the solvability can be formulated by some abstract operators in the quadratic representations. Noting the superposition property for linear state, we can easily check J, K satisfy the parallelogram identity $J(\alpha u_1 + \beta u_2, \alpha v_1 + \beta v_2) + J(\alpha u_1 - \beta u_2, \alpha v_1 - \beta v_2) = 2\alpha^2 J(u_1, v_1) + 2\beta^2 J(u_2, v_2)$ for $\alpha, \beta \in \mathbb{R}$, thus they are quadratic functional.

Proposition 1 *The cost $J(t, \xi; u, v)$ admits the following quadratic functional representation:*

$$J(t, \xi; u, v) = \frac{1}{2} \left[\langle M_1(u), u \rangle + \langle M_2(v), v \rangle + \langle M_3(\xi), \xi \rangle + 2\langle M_{12}(v), u \rangle + 2\langle M_{13}(\xi), u \rangle + 2\langle M_{23}(\xi), v \rangle \right], \quad (3)$$

with self-adjoint linear operators $M_1(\cdot) : \mathcal{U}([t, T]) \rightarrow \mathcal{U}([t, T])$, $M_2(\cdot) : \mathcal{V}([t, T]) \rightarrow \mathcal{V}([t, T])$, $M_3(\cdot) : \mathbb{R}^n \rightarrow \mathbb{R}^n$, and bounded linear operators $M_{12} : \mathcal{V}([t, T]) \rightarrow \mathcal{U}([t, T])$, $M_{13} : \mathbb{R}^n \rightarrow \mathcal{U}([t, T])$, $M_{23} : \mathbb{R}^n \rightarrow \mathcal{V}([t, T])$. Specifically,

$$\begin{cases} M_1(u) = R_{J,1}u + B_1^\top y_1 + D_1^\top z_1, & M_2(v) = R_{J,2}v + B_2^\top y_3 + D_2^\top z_3, & M_3(\xi) = y_2(t), \\ M_{12}(v) = B_1^\top y_3 + D_1^\top z_3, & M_{13}(\xi) = B_1^\top y_2 + D_1^\top z_2, & M_{23}(\xi) = B_2^\top y_2 + D_2^\top z_2, \end{cases}$$

where $(x_1(u), y_1(u))$, $(x_2(\xi), y_2(\xi))$ and $(x_3(v), y_3(v))$ are the solutions of following FBSDEs respectively,

$$\begin{cases} dx_1 = [Ax_1 + B_1u]ds + [Cx_1 + D_1u]dW(s), & x_1(t) = 0, \\ dy_1 = [-A^\top y_1 - C^\top z_1 - Q_1x_1]ds + z_1dW(s), & y_1(T) = G_1x_1(T), \end{cases} \quad (4)$$

$$\begin{cases} dx_2 = Ax_2ds + Cx_2dW(s), & x_2(t) = \xi, \\ dy_2 = [-A^\top y_2 - C^\top z_2 - Q_1x_2]ds + z_2dW(s), & y_2(T) = G_1x_2(T), \end{cases}$$

$$\begin{cases} dx_3 = [Ax_3 + B_2v]ds + [Cx_3 + D_2v]dW(s), & x_3(t) = 0, \\ dy_3 = [-A^\top y_3 - C^\top z_3 - Q_1x_3]ds + z_3dW(s), & y_3(T) = G_1x_3(T). \end{cases} \quad (5)$$

The proof is similar to that of [27, Proposition 6.4.1], and we omit the details here. In parallel, we have the following representation for $K(t, \xi; u, v)$.

Proposition 2 *There exist bounded self-adjoint linear operators $N_1(\cdot) : \mathcal{V}([t, T]) \rightarrow \mathcal{V}([t, T])$, $N_2(\cdot) : \mathcal{U}([t, T]) \rightarrow \mathcal{U}([t, T])$, $N_3(\cdot) : \mathbb{R}^n \rightarrow \mathbb{R}^n$, bounded linear operators $N_{12} : \mathbb{R}^n \rightarrow \mathcal{U}([t, T])$, $N_{13} : \mathcal{U}([t, T]) \rightarrow \mathcal{V}([t, T])$, $N_{23} : \mathbb{R}^n \rightarrow \mathcal{V}([t, T])$ such that*

$$K(t, \xi; u, v) = \frac{1}{2} \left[\langle N_1(v), v \rangle + \langle N_2(u), u \rangle + \langle N_3(\xi), \xi \rangle + 2\langle N_{12}(u), v \rangle + 2\langle N_{13}(\xi), v \rangle + 2\langle N_{23}(\xi), u \rangle \right], \quad (6)$$

where

$$\begin{cases} N_1(v) = R_{K,2}v + B_2^\top Y_3 + D_2^\top Z_3, & N_2(u) = R_{K,1}u + B_1^\top Y_1 + D_1^\top Z_1, & N_3(\xi) = Y_2(t), \\ N_{12}(u) = B_2^\top Y_1 + D_2^\top Z_1, & N_{13}(\xi) = B_2^\top Y_2 + D_2^\top Z_2, & N_{23}(\xi) = B_1^\top Y_2 + D_1^\top Z_2, \end{cases}$$

with $(x_1(u), Y_1(u))$, $(x_2(\xi), Y_2(\xi))$ and $(x_3(v), Y_3(v))$ being the solutions of following FBSDEs respectively,

$$\begin{cases} dx_1 = [Ax_1 + B_1u]ds + [Cx_1 + D_1u]dW(s), & x_1(t) = 0, \\ dY_1 = [-A^\top Y_1 - C^\top Z_1 - Q_2x_1]ds + Z_1dW(s), & Y_1(T) = G_2x_1(T), \\ \\ dx_2 = Ax_2ds + Cx_2dW(s), & x_2(t) = \xi, \\ dY_2 = [-A^\top Y_2 - C^\top Z_2 - Q_2x_2]ds + Z_2dW(s), & Y_2(T) = G_2x_2(T), \\ \\ dx_3 = [Ax_3 + B_2v]ds + [Cx_3 + D_2v]dW(s), & x_3(t) = 0, \\ dY_3 = [-A^\top Y_3 - C^\top Z_3 - Q_2x_3]ds + Z_3dW(s), & Y_3(T) = G_2x_3(T). \end{cases} \quad (7)$$

In particular, for $J(t, \xi; u(\cdot), v(\cdot)) + K(t, \xi; u(\cdot), v(\cdot)) = 0$, we have

$$Q_2 = -Q_1, R_{K,1} = -R_{J,1}, R_{K,2} = -R_{J,2}, G_2 = -G_1.$$

Therefore,

$$N_1 = -M_2, N_2 = -M_1, N_3 = -M_3, N_{12} = -M_{12}^*, N_{13} = -M_{23}, N_{23} = -M_{13},$$

$$(Y_1, Z_1, Y_2, Z_2, Y_3, Z_3) = -(y_1, z_1, y_2, z_2, y_3, z_3).$$

3 Solvabilities of (NG), (NG₀), (SG) and (SG₀)

This section aims to give a unified solution to above problems (NG), (NG₀), (SG) and (SG₀).

3.1 Solvabilities of (NG), (NG₀)

3.1.1 Abstract operator representation

Given the quadratic representations (3) and (6), we have the following solvability results.

Proposition 3 (i) For Problem (NG), there exists a (unique) Nash equilibrium if and only if

$$M_1(\cdot) \geq 0, \quad N_1(\cdot) \geq 0,$$

and there exists a (unique) $(\bar{u}, \bar{v}) \in \mathcal{U}([t, T]) \times \mathcal{V}([t, T])$ such that

$$M_1(\bar{u}) + M_{12}(\bar{v}) + M_{13}(\xi) = 0, \quad N_1(\bar{v}) + N_{12}(\bar{u}) + N_{13}(\xi) = 0.$$

(ii) For Problem (NG₀), there exists a (unique) Nash equilibrium if and only if

$$M_1(\cdot) \geq 0, \quad M_2(\cdot) \leq 0,$$

and there exists a (unique) $(\bar{u}, \bar{v}) \in \mathcal{U}([t, T]) \times \mathcal{V}([t, T])$ such that

$$M_1(\bar{u}) + M_{12}(\bar{v}) + M_{13}(\xi) = 0, \quad M_2(\bar{v}) + M_{12}^*(\bar{u}) + M_{23}(\xi) = 0,$$

where $M_{12}^* : \mathcal{U}([t, T]) \rightarrow \mathcal{V}([t, T])$ is the adjoint operator of M_{12} .

3.1.2 Hamiltonian system representation

The above quadratic functional representations for the solvability are very abstract. Alternatively, it can be reduced to a forward-backward stochastic differential equation (FBSDE) representation through a Fréchet derivative transform:

$$M_1(\bar{u}) + M_{12}(\bar{v}) + M_{13}(\xi) = R_{J,1}\bar{u} + B_1^\top y_1 + D_1^\top z_1 + B_1^\top y_3 + D_1^\top z_3 + B_1^\top y_2 + D_1^\top z_2,$$

$$N_1(\bar{v}(\cdot)) + N_{13}(u) + N_{23}(\xi) = R_{K,2}\bar{v} + B_2^\top Y_3 + D_2^\top Z_3 + B_2^\top Y_1 + D_2^\top Z_1 + B_2^\top Y_2 + D_2^\top Z_2.$$

Note that $x = x_1 + x_2 + x_3$, if we define $y \triangleq y_1 + y_2 + y_3$, $z \triangleq z_1 + z_2 + z_3$, $Y \triangleq Y_1 + Y_2 + Y_3$, $Z \triangleq Z_1 + Z_2 + Z_3$, we have the following result.

Proposition 4 For Problem (NG), $(\bar{u}(\cdot), \bar{v}(\cdot))$ is an open-loop Nash equilibrium if and only if the following conditions are satisfied:

$$(convexity \ condition:) \quad \begin{cases} M_1 \geq 0 \iff \mathbb{E} \int_0^T \langle R_{J,1}u + B_1^\top y_1 + D_1^\top z_1, u \rangle ds \geq 0, \quad \forall u \in \mathcal{U}([t, T]), \\ N_1 \geq 0 \iff \mathbb{E} \int_0^T \langle R_{K,2}v + B_2^\top Y_3 + D_2^\top Z_3, v \rangle ds \geq 0, \quad \forall v \in \mathcal{V}([t, T]), \end{cases} \quad (8)$$

$$(stationary \ condition:) \quad \begin{cases} R_{J,1}(s)\bar{u}(s) + B_1^\top(s)\bar{y}(s) + D_1^\top(s)\bar{z}(s) = 0, \quad s \in [t, T], \quad \mathbb{P} - a.s. \\ R_{K,2}(s)\bar{v}(s) + B_2^\top(s)\bar{Y}(s) + D_2^\top(s)\bar{Z}(s) = 0, \quad s \in [t, T], \quad \mathbb{P} - a.s. \end{cases}$$

where (y_1, z_1) , (Y_3, Z_3) are the solutions of (4), (7), respectively and $(\bar{x}, \bar{y}, \bar{z})$, $(\bar{x}, \bar{Y}, \bar{Z})$ satisfy the following FBSDEs respectively,

$$\begin{cases} d\bar{x} = [A\bar{x} + B_1\bar{u} + B_2\bar{v}] ds + [C\bar{x} + D_1\bar{u} + D_2\bar{v}] dW(s), \\ d\bar{y} = [-A^\top\bar{y} - C^\top\bar{z} - Q_1\bar{x}] ds + \bar{z}dW(s), \\ \bar{x}(t) = \xi, \quad \bar{y}(T) = G_1\bar{x}(T), \end{cases} \quad (9)$$

$$\begin{cases} d\bar{x} = [A\bar{x} + B_1\bar{u} + B_2\bar{v}]ds + [C\bar{x} + D_1\bar{u} + D_2\bar{v}]dW(s), \\ d\bar{Y} = [-A^\top\bar{Y} - C^\top\bar{Z} - Q_2\bar{x}]ds + \bar{Z}dW(s), \\ \bar{x}(t) = \xi, \quad \bar{Y}(T) = G_2\bar{x}(T). \end{cases} \quad (10)$$

Moreover, in case $R_{J,1}(\cdot), R_{K,2}(\cdot)$ are invertible and $R_{J,1}(\cdot) \in L^\infty(t, T; \mathbb{S}^{m_1}), R_{K,2}(\cdot) \in L^\infty(t, T; \mathbb{S}^{m_2})$, the Nash equilibrium becomes

$$\begin{cases} \bar{u}(s) = -R_{J,1}^{-1}(s)[B_1^\top(s)\bar{y}(s) + D_1^\top(s)\bar{z}(s)], \quad s \in [t, T], \quad \mathbb{P} - a.s. \\ \bar{v}(s) = -R_{K,2}^{-1}(s)[B_2^\top(s)\bar{Y}(s) + D_2^\top(s)\bar{Z}(s)], \quad s \in [t, T], \quad \mathbb{P} - a.s. \end{cases} \quad (11)$$

and the corresponding optimal functionals become

$$\begin{aligned} J(t, \xi; \bar{u}, \bar{v}) &= \mathbb{E} \left\{ \int_t^T \langle R_{J,2}R_{K,2}^{-1}(B_2^\top\bar{Y} + D_2^\top\bar{Z}) - B_2^\top\bar{y} - D_2^\top\bar{z}, R_{K,2}^{-1}(B_2^\top\bar{Y} + D_2^\top\bar{Z}) \rangle ds + \langle \bar{x}(t), \bar{y}(t) \rangle \right\}, \\ K(t, \xi; \bar{u}, \bar{v}) &= \mathbb{E} \left\{ \int_t^T \langle R_{K,1}R_{J,1}^{-1}(B_1^\top\bar{y} + D_1^\top\bar{z}) - B_1^\top\bar{Y} - D_1^\top\bar{Z}, R_{J,1}^{-1}(B_1^\top\bar{y} + D_1^\top\bar{z}) \rangle ds + \langle \bar{x}(t), \bar{Y}(t) \rangle \right\}. \end{aligned}$$

Proposition 5 For Problem (NG₀), $(\bar{u}(\cdot), \bar{v}(\cdot))$ is an open-loop Nash equilibrium if and only if the following conditions are satisfied:

$$(convexity \ condition:) \quad \begin{cases} M_1 \geq 0 \iff \mathbb{E} \int_0^T \langle R_{J,1}u + B_1^\top y_1 + D_1^\top z_1, u \rangle ds \geq 0, \quad \forall u \in \mathcal{U}([t, T]), \\ M_2 \leq 0 \iff \mathbb{E} \int_0^T \langle R_{J,2}v + B_2^\top y_3 + D_2^\top z_3, v \rangle ds \leq 0, \quad \forall v \in \mathcal{V}([t, T]), \end{cases} \quad (12)$$

$$(stationary \ condition:) \quad \begin{cases} R_{J,1}(s)\bar{u}(s) + B_1^\top(s)\bar{y}(s) + D_1^\top(s)\bar{z}(s) = 0, \quad s \in [t, T], \quad \mathbb{P} - a.s. \\ R_{J,2}(s)\bar{v}(s) + B_2^\top(s)\bar{Y}(s) + D_2^\top(s)\bar{Z}(s) = 0, \quad s \in [t, T], \quad \mathbb{P} - a.s. \end{cases}$$

where (y_1, z_1) is the solution of (4), (y_3, z_3) is the solution of (5), and $(\bar{x}, \bar{y}, \bar{z})$ is the solution of (9). Moreover, in case $R_{J,1}(\cdot), R_{J,2}(\cdot)$ are invertible and $R_{J,1}(\cdot) \in L^\infty(t, T; \mathbb{S}^{m_1}), R_{J,2}(\cdot) \in L^\infty(t, T; \mathbb{S}^{m_2})$, the Nash equilibrium becomes

$$\begin{cases} \bar{u}(s) = -R_{J,1}^{-1}(s)[B_1^\top(s)\bar{y}(s) + D_1^\top(s)\bar{z}(s)], \quad s \in [t, T], \quad \mathbb{P} - a.s. \\ \bar{v}(s) = -R_{J,2}^{-1}(s)[B_2^\top(s)\bar{Y}(s) + D_2^\top(s)\bar{Z}(s)], \quad s \in [t, T], \quad \mathbb{P} - a.s. \end{cases} \quad (13)$$

and the corresponding optimal functionals become

$$J(t, \xi; \bar{u}, \bar{v}) = \mathbb{E} \langle \bar{x}(t), \bar{y}(t) \rangle = -K(t, \xi; \bar{u}, \bar{v}).$$

3.1.3 Riccati equation representation

The Nash equilibriums in (11) and (13) are of open-loop forms. In this subsection, we will introduce Riccati equation to give closed-loop representations. To do this, plugging (11) into (9) and (10), we have the Hamiltonian system

$$\begin{cases} d\bar{x} = [A\bar{x} - \hat{B}_1\bar{y} - \hat{D}_1^\top\bar{z} - \hat{B}_2\bar{Y} - \hat{D}_2\bar{Z}]ds + [C\bar{x} - \hat{D}_1\bar{y} - \hat{F}_2\bar{z} - \hat{D}_2^\top\bar{Y} - \hat{D}_3\bar{Z}]dW(s), \\ d\bar{y} = [-A^\top\bar{y} - C^\top\bar{z} - Q_1\bar{x}]ds + \bar{z}dW(s), \\ d\bar{Y} = [-A^\top\bar{Y} - C^\top\bar{Z} - Q_2\bar{x}]ds + \bar{Z}dW(s), \\ \bar{x}(t) = \xi, \quad \bar{y}(T) = G_1\bar{x}(T), \quad \bar{Y}(T) = G_2\bar{x}(T), \end{cases} \quad (14)$$

where

$$\begin{aligned}\widehat{B}_1 &= B_1 R_{J,1}^{-1} B_1^\top, \widehat{B}_2 = B_2 R_{K,2}^{-1} B_2^\top, \widehat{D}_1 = D_1 R_{J,1}^{-1} B_1^\top, \widehat{D}_2 = B_2 R_{K,2}^{-1} D_2^\top, \\ \widehat{D}_3 &= D_2 R_{K,2}^{-1} D_2^\top, \widehat{F}_2 = D_1 R_{J,1}^{-1} D_1^\top.\end{aligned}\quad (15)$$

(14) can be written as

$$\begin{cases} d\bar{x} = [A\bar{x} + \mathbf{B}_1 \mathbf{Y} + \mathbf{B}_2 \mathbf{Z}] ds + [C\bar{x} + \mathbf{D}_1 \mathbf{Y} + \mathbf{D}_2 \mathbf{Z}] dW(s), \\ d\mathbf{Y} = [-\mathbf{A}^\top \mathbf{Y} - \mathbf{C}^\top \mathbf{Z} - \mathbf{Q} \mathbf{I}_n x] ds + \mathbf{Z} dW(s), \\ \bar{x}(t) = \xi, \quad \mathbf{Y}(T) = \mathbf{G} \mathbf{I}_n x(T), \end{cases}\quad (16)$$

where

$$\begin{aligned}\mathbf{Y} &= \begin{pmatrix} \bar{y} \\ \bar{Y} \end{pmatrix}, \mathbf{Z} = \begin{pmatrix} \bar{z} \\ \bar{Z} \end{pmatrix}, \mathbf{B}_1 = \begin{pmatrix} -\widehat{B}_1 & -\widehat{B}_2 \end{pmatrix}, \mathbf{B}_2 = \begin{pmatrix} -\widehat{D}_1^\top & -\widehat{D}_2 \end{pmatrix}, \mathbf{D}_1 = \begin{pmatrix} -\widehat{D}_1 & -\widehat{D}_2^\top \end{pmatrix}, \\ \mathbf{D}_2 &= \begin{pmatrix} -\widehat{F}_2 & -\widehat{D}_3 \end{pmatrix}, \mathbf{A} = \begin{pmatrix} A & 0 \\ 0 & A \end{pmatrix}, \mathbf{C} = \begin{pmatrix} C & 0 \\ 0 & C \end{pmatrix}, \mathbf{Q} = \begin{pmatrix} Q_1 & 0 \\ 0 & Q_2 \end{pmatrix}, \mathbf{I}_n = \begin{pmatrix} I_n \\ I_n \end{pmatrix}, \mathbf{G} = \begin{pmatrix} G_1 & 0 \\ 0 & G_2 \end{pmatrix}.\end{aligned}$$

Let $\mathbf{Y} = \Pi \bar{x}$ with $\Pi = \begin{pmatrix} \Pi_1 \\ \Pi_2 \end{pmatrix}$, we have

$$\mathbf{Z} = (I_{2n} - \Pi \mathbf{D}_2)^{-1} (\Pi C + \Pi \mathbf{D}_1 \Pi) \bar{x},$$

and

$$\begin{cases} \dot{\Pi} + \Pi A + \mathbf{A}^\top \Pi + \Pi \mathbf{B}_1 \Pi + \mathbf{Q} \mathbf{I}_n + \Pi \mathbf{B}_2 (I_{2n} - \Pi \mathbf{D}_2)^{-1} (\Pi C + \Pi \mathbf{D}_1 \Pi) \\ + \mathbf{C}^\top (I_{2n} - \Pi \mathbf{D}_2)^{-1} (\Pi C + \Pi \mathbf{D}_1 \Pi) = 0, \\ \Pi(T) = \mathbf{G} \mathbf{I}_n. \end{cases}\quad (17)$$

Therefore, the Nash equilibrium (11) has the following representation:

$$\begin{cases} \bar{u}(s) = -R_{J,1}^{-1}(s) (B_1^\top(s) 0) \Pi(s) x(s) - R_{J,1}^{-1}(s) (D_1^\top(s) 0) (I_{2n} - \Pi \mathbf{D}_2)^{-1} (\Pi C + \Pi \mathbf{D}_1 \Pi) \bar{x} := \theta_1 \bar{x}, \\ \bar{v}(s) = -R_{K,2}^{-1}(s) (0 B_2^\top(s)) \Pi(s) x(s) - R_{K,2}^{-1}(s) (0 D_2^\top(s)) (I_{2n} - \Pi \mathbf{D}_2)^{-1} (\Pi C + \Pi \mathbf{D}_1 \Pi) \bar{x} := \theta_2 \bar{x}. \end{cases}\quad (18)$$

By $\mathbf{Y} = \Pi \bar{x}$ and $\mathbf{Z} = (I_n - \Pi \mathbf{D}_2)^{-1} (\Pi C + \Pi \mathbf{D}_1 \Pi) \bar{x}$, we have

$$d\bar{x} = \mathbf{a} \bar{x} ds + \mathbf{b} \bar{x} dW, \quad \bar{x}(t) = \xi,$$

where

$$\mathbf{a} = A + \mathbf{B}_1 \Pi + \mathbf{B}_2 (I_{2n} - \Pi \mathbf{D}_2)^{-1} (\Pi C + \Pi \mathbf{D}_1 \Pi), \mathbf{b} = C + \mathbf{D}_1 \Pi + \mathbf{D}_2 (I_{2n} - \Pi \mathbf{D}_2)^{-1} (\Pi C + \Pi \mathbf{D}_1 \Pi).$$

Plugging (18) into (2), we have

$$J(t, \xi; \bar{u}, \bar{v}) = \mathbb{E} \left\{ \int_t^T \langle \mathbf{q}_1(s) \bar{x}(s), \bar{x}(s) \rangle ds + \langle G_1 \bar{x}(T), \bar{x}(T) \rangle \right\},$$

where

$$\mathbf{q}_1 = Q_1 + \theta_1^\top R_{J,1} \theta_1 + \theta_2^\top R_{J,2} \theta_2.$$

Introduce the following Riccati equation,

$$\dot{\hat{p}}_1 + \hat{p}_1 \mathbf{a}_1 + \mathbf{a}_1^\top \hat{p}_1 + \mathbf{b}_1^\top \hat{p}_1 \mathbf{b}_1 + \mathbf{q}_1 = 0, \quad \hat{p}_1(T) = G_1, \quad (19)$$

we have the optimal functional for player 1 as follows:

$$J(t, \xi; \bar{u}, \bar{v}) = \mathbb{E}\langle \hat{p}_1(t)\xi, \xi \rangle.$$

Similarly, the optimal functional for player 2 is

$$K(t, \xi; \bar{u}, \bar{v}) = \mathbb{E}\langle \tilde{p}_1(t)\xi, \xi \rangle,$$

where \tilde{p}_1 is the solution of the following Riccati equation

$$\dot{\tilde{p}}_1 + \tilde{p}_1 \mathbf{a}_1 + \mathbf{a}_1^\top \tilde{p}_1 + \mathbf{b}_1^\top \tilde{p}_1 \mathbf{b}_1 + \mathbf{q}_2 = 0, \quad \tilde{p}_1(T) = G_2, \quad (20)$$

with

$$\mathbf{q}_2 = Q_2 + \theta_1^\top R_{K,1} \theta_1 + \theta_2^\top R_{K,2} \theta_2.$$

Proposition 6 For (NG), suppose that equations (17), (19) and (20) admit solutions such that $I_n - \Pi \mathbf{D}_2$ is invertible, then the Nash equilibrium (11) has the following representation:

$$\begin{cases} \bar{u}(s) = -R_{J,1}^{-1} (B_1^\top \ 0) \Pi \bar{x} - R_{J,1}^{-1} (D_1^\top \ 0) (I_n - \Pi \mathbf{D}_2)^{-1} (\Pi C + \Pi \mathbf{D}_1 \Pi) \bar{x}, \\ \bar{v}(s) = -R_{K,2}(s)^{-1} (0 \ B_2^\top) \Pi \bar{x} - R_{J,1}^{-1} (0 \ D_2^\top) (I_n - \Pi \mathbf{D}_2)^{-1} (\Pi C + \Pi \mathbf{D}_1 \Pi) \bar{x}. \end{cases}$$

Furthermore, the optimal costs take the following form:

$$J(t, \xi; \bar{u}, \bar{v}) = \mathbb{E}\langle \hat{p}_1(t)\xi, \xi \rangle, \quad K(t, \xi; \bar{u}, \bar{v}) = \mathbb{E}\langle \tilde{p}_1(t)\xi, \xi \rangle,$$

where \hat{p} and \tilde{p} are the solutions of (19) and (20) respectively.

For (NG₀), (14) reduces to

$$\begin{cases} d\bar{x} = [A\bar{x} - \hat{B}_1 \bar{y} - \hat{D}_1^\top \bar{z} + \hat{B}_2 \bar{y} + \hat{D}_2 \bar{z}] ds + [C\bar{x} - \hat{D}_1 \bar{y} - \hat{F}_2 \bar{z} + \hat{D}_2^\top \bar{y} + \hat{D}_3 \bar{z}] dW(s), \\ d\bar{y} = [-A^\top \bar{y} - C^\top \bar{z} - Q_1 \bar{x}] ds + \bar{z} dW(s), \\ \bar{x}(t) = \xi, \quad \bar{y}(T) = G_1 \bar{x}(T). \end{cases} \quad (21)$$

Let $\bar{y} = \Pi_1 \bar{x}$, we have

$$\bar{z} = (I + \Pi_1 (\hat{F}_2 - \hat{D}_3))^{-1} (\Pi_1 C - \Pi_1 (\hat{D}_1 - \hat{D}_2^\top) \Pi_1) \bar{x},$$

and

$$\begin{cases} \dot{\Pi}_1 + \Pi_1 A + A^\top \Pi_1 - \Pi_1 (\hat{B}_1 - \hat{B}_2) \Pi_1 - \Pi_1 (\hat{D}_1^\top - \hat{D}_2) (I + \Pi_1 (\hat{F}_2 - \hat{D}_3))^{-1} (\Pi_1 C - \Pi_1 (\hat{D}_1 - \hat{D}_2^\top) \Pi_1) \\ + C^\top (I + \Pi_1 (\hat{F}_2 - \hat{D}_3))^{-1} (\Pi_1 C - \Pi_1 (\hat{D}_1 - \hat{D}_2^\top) \Pi_1) + Q_1 = 0, \\ \Pi_1(T) = G_1. \end{cases} \quad (22)$$

Note that if Π_1 is symmetric, we have

$$\Pi_1 ((I + \Pi_1 (\hat{F}_2 - \hat{D}_3))^{-1})^\top = \Pi_1 (I + (\hat{F}_2 - \hat{D}_3) \Pi_1)^{-1} = (I + \Pi_1 (\hat{F}_2 - \hat{D}_3))^{-1} \Pi_1.$$

Then the Nash equilibrium (11) has the following representation:

$$\begin{cases} \bar{u}(s) = -R_{J,1}^{-1} (B_1^\top \ \Pi_1 + D_1^\top (I + \Pi_1 (\hat{F}_2 - \hat{D}_3))^{-1} (\Pi_1 C - \Pi_1 (\hat{D}_1 - \hat{D}_2^\top) \Pi_1)) \bar{x} := \hat{\theta}_1 \bar{x}, \\ \bar{v}(s) = -R_{J,2}^{-1} (B_2^\top \ \Pi_1 + D_2^\top (I + \Pi_1 (\hat{F}_2 - \hat{D}_3))^{-1} (\Pi_1 C - \Pi_1 (\hat{D}_1 - \hat{D}_2^\top) \Pi_1)) \bar{x} := \hat{\theta}_2 \bar{x}. \end{cases} \quad (23)$$

Therefore,

$$J(t, \xi; \bar{u}, \bar{v}) = \mathbb{E} \left\{ \int_t^T \langle \mathbf{q}_1(s) \bar{x}(s), \bar{x}(s) \rangle ds + \langle G_1 \bar{x}(T), \bar{x}(T) \rangle \right\},$$

where

$$d\bar{x} = \mathbf{a}_2 \bar{x} ds + \mathbf{b}_2 \bar{x} dW, \quad \bar{x}(t) = \xi,$$

$$\mathbf{a}_2 = A - (\hat{B}_1 - \hat{B}_2) \Pi_1 - (\hat{D}_1^\top - \hat{D}_2)(I + \Pi_1(\hat{F}_2 - \hat{D}_3))^{-1}(\Pi_1 C - \Pi_1(\hat{D}_1 - \hat{D}_2^\top) \Pi_1), \quad (24)$$

$$\mathbf{b}_2 = C - (\hat{D}_1 - \hat{D}_2^\top) \Pi_1 - (\hat{F}_2 - \hat{D}_3)(I + \Pi_1(\hat{F}_2 - \hat{D}_3))^{-1}(\Pi_1 C - \Pi_1(\hat{D}_1 - \hat{D}_2^\top) \Pi_1),$$

$$\mathbf{q}_1 = Q_1 + \hat{\theta}_1^\top R_{J,1} \hat{\theta}_1 + \hat{\theta}_2^\top R_{J,2} \hat{\theta}_2. \quad (25)$$

Introduce the following Riccati equation,

$$\dot{\hat{p}}_2 + \hat{p}_2 \mathbf{a}_2 + \mathbf{a}_2^\top \hat{p}_2 + \mathbf{b}_2^\top \hat{p}_2 \mathbf{b}_2 + \mathbf{q}_1 = 0, \quad \hat{p}_2(T) = G_1, \quad (26)$$

the optimal functionals become

$$J(t, \xi; \bar{u}, \bar{v}) = \mathbb{E} \langle \hat{p}_2(t) \xi, \xi \rangle = -K(t, \xi; \bar{u}, \bar{v}).$$

Proposition 7 For (NG₀), suppose that equations (22) and (26) admit solutions such that $I + \Pi_1(\hat{F}_2 - \hat{D}_3)$ is invertible, then the Nash equilibrium has the following representation:

$$\begin{cases} \bar{u}(s) = -R_{J,1}^{-1}(B_1^\top \Pi_1 + D_1^\top (I + \Pi_1(\hat{F}_2 - \hat{D}_3))^{-1}(\Pi_1 C - \Pi_1(\hat{D}_1 - \hat{D}_2^\top) \Pi_1)) \bar{x}, \\ \bar{v}(s) = -R_{J,2}^{-1}(B_2^\top \Pi_1 + D_2^\top (I + \Pi_1(\hat{F}_2 - \hat{D}_3))^{-1}(\Pi_1 C - \Pi_1(\hat{D}_1 - \hat{D}_2^\top) \Pi_1)) \bar{x}. \end{cases} \quad (27)$$

Furthermore, the optimal costs become

$$J(t, \xi; \bar{u}, \bar{v}) = \mathbb{E} \langle \hat{p}_2(t) \xi, \xi \rangle = -K(t, \xi; \bar{u}, \bar{v}),$$

where \hat{p}_2 is the solution of (26).

Next, by (27), (24) and (25), we can rewrite (26) as follows

$$\begin{cases} \dot{\hat{p}}_2 + \hat{p}_2 A - \hat{p}_2 (\hat{B}_1 - \hat{B}_2) \Pi_1 - \hat{p}_2 (\hat{D}_1^\top - \hat{D}_2)(I + \Pi_1(\hat{F}_2 - \hat{D}_3))^{-1}(\Pi_1 C - \Pi_1(\hat{D}_1 - \hat{D}_2^\top) \Pi_1) \\ + A^\top \hat{p}_2 - \Pi_1 (\hat{B}_1 - \hat{B}_2) \hat{p}_2 - (\Pi_1 C - \Pi_1(\hat{D}_1 - \hat{D}_2^\top) \Pi_1)^\top (I + (\hat{F}_2 - \hat{D}_3) \Pi_1)^{-1} (\hat{D}_1 - \hat{D}_2^\top) \hat{p}_2 \\ + (C - (\hat{D}_1 - \hat{D}_2^\top) \Pi_1 - (\hat{F}_2 - \hat{D}_3)(I + \Pi_1(\hat{F}_2 - \hat{D}_3))^{-1}(\Pi_1 C - \Pi_1(\hat{D}_1 - \hat{D}_2^\top) \Pi_1))^\top \hat{p}_2 \\ (C - (\hat{D}_1 - \hat{D}_2^\top) \Pi_1 - (\hat{F}_2 - \hat{D}_3)(I + \Pi_1(\hat{F}_2 - \hat{D}_3))^{-1}(\Pi_1 C - \Pi_1(\hat{D}_1 - \hat{D}_2^\top) \Pi_1)) + Q_1 \\ + (\Pi_1 B_1 + (\Pi_1 C - \Pi_1(\hat{D}_1 - \hat{D}_2^\top) \Pi_1)^\top (I + (\hat{F}_2 - \hat{D}_3) \Pi_1)^{-1} D_1) R_{J,1}^{-1} \\ (B_1^\top \Pi_1 + D_1^\top (I + \Pi_1(\hat{F}_2 - \hat{D}_3))^{-1}(\Pi_1 C - \Pi_1(\hat{D}_1 - \hat{D}_2^\top) \Pi_1)) \\ + (\Pi_1 B_2 + (\Pi_1 C - \Pi_1(\hat{D}_1 - \hat{D}_2^\top) \Pi_1)^\top (I + (\hat{F}_2 - \hat{D}_3) \Pi_1)^{-1} D_1) R_{J,2}^{-1} \\ (B_2^\top \Pi_1 + D_2^\top (I + \Pi_1(\hat{F}_2 - \hat{D}_3))^{-1}(\Pi_1 C - \Pi_1(\hat{D}_1 - \hat{D}_2^\top) \Pi_1)) = 0, \\ \hat{p}_2(T) = G_1, \end{cases} \quad (28)$$

Note that

$$\begin{aligned}
& C^\top (I + \Pi_1(\hat{F}_2 - \hat{D}_3))^{-1} (\Pi_1 C - \Pi_1(\hat{D}_1 - \hat{D}_2^\top) \Pi_1) \\
&= -\Pi_1(\hat{B}_1 - \hat{B}_2) \Pi_1 - (\Pi_1 C - \Pi_1(\hat{D}_1 - \hat{D}_2^\top) \Pi_1)^\top (I + (\hat{F}_2 - \hat{D}_3) \Pi_1)^{-1} (\hat{D}_1 - \hat{D}_2^\top) \Pi_1 \\
&\quad + (C - (\hat{D}_1 - \hat{D}_2^\top) \Pi_1 - (\hat{F}_2 - \hat{D}_3)(I + \Pi_1(\hat{F}_2 - \hat{D}_3))^{-1} (\Pi_1 C - \Pi_1(\hat{D}_1 - \hat{D}_2^\top) \Pi_1))^\top \Pi_1 \\
&\quad (C - (\hat{D}_1 - \hat{D}_2^\top) \Pi_1 - (\hat{F}_2 - \hat{D}_3)(I + \Pi_1(\hat{F}_2 - \hat{D}_3))^{-1} (\Pi_1 C - \Pi_1(\hat{D}_1 - \hat{D}_2^\top) \Pi_1)) \\
&\quad + (\Pi_1 B_1 + (\Pi_1 C - \Pi_1(\hat{D}_1 - \hat{D}_2^\top) \Pi_1)^\top (I + (\hat{F}_2 - \hat{D}_3) \Pi_1)^{-1} D_1) R_{j,1}^{-1} \\
&\quad (B_1^\top \Pi_1 + D_1^\top (I + \Pi_1(\hat{F}_2 - \hat{D}_3))^{-1} (\Pi_1 C - \Pi_1(\hat{D}_1 - \hat{D}_2^\top) \Pi_1)) \\
&\quad + (\Pi_1 B_2 + (\Pi_1 C - \Pi_1(\hat{D}_1 - \hat{D}_2^\top) \Pi_1)^\top (I + (\hat{F}_2 - \hat{D}_3) \Pi_1)^{-1} D_1) R_{j,2}^{-1} \\
&\quad (B_2^\top \Pi_1 + D_2^\top (I + \Pi_1(\hat{F}_2 - \hat{D}_3))^{-1} (\Pi_1 C - \Pi_1(\hat{D}_1 - \hat{D}_2^\top) \Pi_1)),
\end{aligned}$$

Let $\Phi = \Pi_1 - \hat{p}_2$, by (22) and (28), we have

$$\left\{ \begin{array}{l} \dot{\Phi} + \Phi A + A^\top \Phi - \Phi(\hat{B}_1 - \hat{B}_2) \Pi_1 - \Phi(\hat{D}_1^\top - \hat{D}_2)(I + \Pi_1(\hat{F}_2 - \hat{D}_3))^{-1} (\Pi_1 C - \Pi_1(\hat{D}_1 - \hat{D}_2^\top) \Pi_1) \\ - \Pi_1(\hat{B}_1 - \hat{B}_2) \Phi - (\Pi_1 C - \Pi_1(\hat{D}_1 - \hat{D}_2^\top) \Pi_1)^\top (I + (\hat{F}_2 - \hat{D}_3) \Pi_1)^{-1} (\hat{D}_1 - \hat{D}_2^\top) \Phi \\ + (C - (\hat{D}_1 - \hat{D}_2^\top) \Pi_1 - (\hat{F}_2 - \hat{D}_3)(I + \Pi_1(\hat{F}_2 - \hat{D}_3))^{-1} (\Pi_1 C - \Pi_1(\hat{D}_1 - \hat{D}_2^\top) \Pi_1))^\top \Phi \\ (C - (\hat{D}_1 - \hat{D}_2^\top) \Pi_1 - (\hat{F}_2 - \hat{D}_3)(I + \Pi_1(\hat{F}_2 - \hat{D}_3))^{-1} (\Pi_1 C - \Pi_1(\hat{D}_1 - \hat{D}_2^\top) \Pi_1)) = 0, \\ \Phi(T) = 0, \end{array} \right.$$

Therefore, $\Phi(\cdot) = 0$, i.e.,

$$\Pi_1(\cdot) = \hat{p}_2(\cdot), \quad (29)$$

that is, for (NG_0) , the Riccati equation Π_1 (representing the optimal strategies) and Riccati equation \hat{p}_2 (representing the optimal functionals) are the same.

3.1.4 Time-consistency of NG_0 , NG

Definition 1 An Nash equilibrium $(\bar{u}(\cdot), \bar{v}(\cdot)) \in \mathcal{U}([t, T]) \times \mathcal{V}([t, T])$ is called time-consistent, if

$$\left\{ \begin{array}{l} \bar{u}(\cdot; t, \xi)|_{[s, T]} = \bar{u}(\cdot; s', \bar{x}(s'; t, \xi))|_{[s, T]}, \quad t \leq s' \leq s \leq T, \\ \bar{v}(\cdot; t, \xi)|_{[s, T]} = \bar{v}(\cdot; s', \bar{x}(s'; t, \xi))|_{[s, T]}, \quad t \leq s' \leq s \leq T, \end{array} \right.$$

or

$$\left\{ \begin{array}{l} \inf_{u(\cdot) \in \mathcal{U}([s, T])} J(s, \bar{x}(s; t, \xi); u(\cdot), \bar{v}(\cdot)|_{[s, T]}) = J(s, \bar{x}(s; t, \xi); \bar{u}(\cdot)|_{[s, T]}, \bar{v}(\cdot)|_{[s, T]}), \quad t < s < T, \\ \inf_{v(\cdot) \in \mathcal{V}([s, T])} K(s, \bar{x}(s; t, \xi); \bar{u}(\cdot)|_{[s, T]}, v(\cdot)) = K(s, \bar{x}(s; t, \xi); \bar{u}(\cdot)|_{[s, T]}, \bar{v}(\cdot)|_{[s, T]}), \quad t < s < T, \end{array} \right.$$

where $\bar{x}(\cdot)$ is the solution of following Hamiltonian system on $[t, T]$,

$$\left\{ \begin{array}{l} d\bar{x} = [A\bar{x} - \hat{B}_1\bar{y} - \hat{D}_1^\top\bar{z} - \hat{B}_2\bar{Y} - \hat{D}_2\bar{Z}]ds + [C\bar{x} - \hat{D}_1\bar{y} - \hat{F}_2\bar{z} - \hat{D}_2^\top\bar{Y} - \hat{D}_3\bar{Z}]dW(s), \\ d\bar{y} = [-A^\top\bar{y} - C^\top\bar{z} - Q_1\bar{x}]ds + \bar{z}dW(s), \\ d\bar{Y} = [-A^\top\bar{Y} - C^\top\bar{Z} - Q_2\bar{x}]ds + \bar{Z}dW(s), \\ \bar{x}(t) = \xi, \quad \bar{y}(T) = G_1\bar{x}(T), \quad \bar{Y}(T) = G_2\bar{x}(T). \end{array} \right. \quad (30)$$

Note that the time-consistency is related to FBSDE (30), thus in the following we give a definition of time-consistency for FBSDE.

Definition 2 Let $\bar{x}(s'; t, \xi, T, G_1, G_2)$ be the solution of (30) at $s' \in [t, T]$. For $(s', \bar{x}(s'; t, \xi, T, G_1, G_2)) \in (t, T) \times L^2_{\mathcal{F}_{s'}}(\Omega; \mathbb{R}^n)$, consider FBSDE (30) on $[s', T]$ with initial state $\bar{x}(s') = \bar{x}(s'; t, \xi, T, G_1, G_2)$. Then FBSDE (30) is called time-consistent, if

$$\psi(s; t, \xi, T, G_1, G_2) = \psi(s; s', \bar{x}(s'; t, \xi, T, G_1, G_2)), \quad t \leq s' \leq s \leq T,$$

for $\psi = \bar{x}, \bar{y}, \bar{z}, \bar{Y}, \bar{Z}$.

From the uniqueness of FBSDE, we have

$$\psi(s; t, \xi, T, G_1, G_2) = \psi(s; s', \bar{x}(s'; t, \xi, T, G_1, G_2)), \quad t \leq s' \leq s \leq T,$$

where $\psi = \bar{x}, \bar{y}, \bar{z}, \bar{Y}, \bar{Z}$, that is FBSDE (30) is time-consistent if it is uniquely solvable.

Furthermore, for Hamiltonian system and Nash equilibrium, we may introduce the following operators. For any $(t, x) \in (0, T) \times L^2_{\mathcal{F}_t}(\Omega; \mathbb{R}^n)$, define $\mathbf{T} \cdot (t, x) := (\bar{x}(\cdot), \bar{y}(\cdot), \bar{z}(\cdot), \bar{Y}(\cdot), \bar{Z}(\cdot))|_{[t, T]}$ for the Hamiltonian system (30) defined on $[t, T]$ with initials (t, ξ) . Then, we have the following semi-group property for the family of operators $\{T(t, x)\}$.

Proposition 8 *If FBSDE (30) admits a unique solution, then the family of operators satisfies*

$$\mathbf{T}_s(t, x) = \mathbf{T}_s(s', \mathbf{T}_{s'}(t, x)), \quad 0 < t < s' < s < T, x \in L^2_{\mathcal{F}_t}(\Omega; \mathbb{R}^n).$$

3.2 Solvabilities of (SG) and (SG₀)

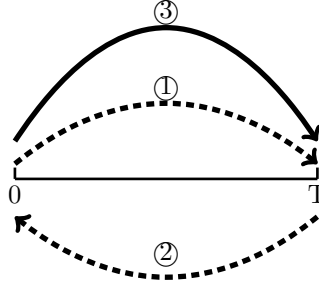

FIG. 1. A “6” scheme. The paradigm of a classical leader-follower game can be sketched by a visualized “6” scheme with three consecutive arrows: by *dashed* arrow 1, leader \mathcal{A}_L pre-commit his decision on forward horizon as spanning by the arrow length; by consecutive dashed arrow 2, we mean follower \mathcal{A}_F will compute the best response based on arrow 1. These two dashed arrows formalize a closed cycle while “dash” feature emphasizes related decisions are rather generic from admissible sets, and not the optimal ones to be really implemented. Last, keep above decision cycle in mind, \mathcal{A}_L update his cost functional to be iterative and implement the optimal decision accordingly. Thus, a solid arrow 3 is depicted. All three consecutive arrows together are similar to a handwritten number “6” in shape so we may call it a “6” scheme. Noting it essentially depends on commitment information set by arrow 1.

3.2.1 Abstract operator representation

First, by the representations (3) and (6), we establish the solvability of (SG) by the operator representation. In principle, its solvability is divided into two steps: *best response* and *iterative approach*.

Proposition 9 *Under (H1)-(H2), for Problem (SG), suppose that $M_1 \gg 0$ and $M_2 \geq 0$, then the Stackelberg equilibrium satisfies*

$$\begin{cases} \bar{u}(v(\cdot))(\cdot) = M_1^{-1}(-M_{12}(v) - M_{13}(\xi)), \\ 0 = [N_1 + M_{12}^*(M_1^{-1})^*N_2M_1^{-1}M_{12} - 2N_{12}M_1^{-1}M_{12}]\bar{v}(\cdot) \\ \quad - [M_{12}^*(M_1^{-1})^*N_2M_1^{-1}M_{13} - N_{12}M_1^{-1}M_{13} - M_{12}^*(M_1^{-1})^*N_{13} + N_{13}](\xi). \end{cases} \quad (31)$$

Proof For fixed $v(\cdot) \in \mathcal{V}([t, T])$, the cost functional of \mathcal{A}_F takes the following representation:

$$J(t, \xi, v(\cdot); u(\cdot)) = \frac{1}{2} \left\{ \langle M_1(u), u \rangle + 2\langle M_{12}(v) + M_{13}(\xi), u \rangle + \left[\langle M_2(v), v \rangle + \langle M_3(\xi), \xi \rangle + 2\langle M_{23}(\xi), v \rangle \right] \right\}.$$

Note that here $(\xi, v(\cdot)) \in \mathbb{R}^n \times \mathcal{V}([t, T])$ are both fixed. If $M_1 \gg 0$, then M_1^{-1} is well-defined and bounded. Therefore, the optimal strategy of \mathcal{A}_F denoted by $\bar{u}(\cdot)$ can be viewed as a best response for fixed $v(\cdot)$ and is given by

$$\bar{u}(v(\cdot))(\cdot) = M_1^{-1}(-M_{12}(v) - M_{13}(\xi)). \quad (32)$$

Given $\bar{u}(\cdot)$ of \mathcal{A}_F , \mathcal{A}_L is now facing the following iterative cost functional:

$$\begin{aligned} & K(v(\cdot), \bar{u}(v(\cdot))(\cdot); \xi) \\ &= \frac{1}{2} \left[\langle N_1(v), v \rangle + \langle N_2(M_1^{-1}(-M_{12}(v) - M_{13}(\xi))), M_1^{-1}(-M_{12}(v) - M_{13}(\xi)) \rangle + \langle N_3(\xi), \xi \rangle \right. \\ & \quad \left. + 2\langle N_{12}(M_1^{-1}(-M_{12}(v) - M_{13}(\xi))), v \rangle + 2\langle N_{13}(\xi), M_1^{-1}(-M_{12}(v) - M_{13}(\xi)) \rangle + 2\langle N_{23}(\xi), v \rangle \right] \\ &= \frac{1}{2} \left[\langle N_1(v) + M_{12}^*(M_1^{-1})^*N_2M_1^{-1}M_{12}(v) - 2N_{12}M_1^{-1}M_{12}(v), v \rangle \right. \\ & \quad \left. + 2\langle M_{12}^*(M_1^{-1})^*N_2M_1^{-1}M_{13}(\xi) - N_{12}M_1^{-1}M_{13}(\xi) - M_{12}^*(M_1^{-1})^*N_{13}(\xi) + N_{13}(\xi), v \rangle \right. \\ & \quad \left. + \langle N_3(\xi) + M_{13}^*(M_1^{-1})^*N_2M_1^{-1}M_{13}(\xi) - 2M_{13}^*(M_1^{-1})^*N_{13}(\xi), \xi \rangle \right], \end{aligned}$$

where for given operator \mathcal{M} , \mathcal{M}^* is the adjoint operator of \mathcal{M} . Therefore, the optimal strategy of \mathcal{A}_L satisfies

$$\begin{aligned} 0 &= [N_1 + M_{12}^*(M_1^{-1})^*N_2M_1^{-1}M_{12} - 2N_{12}M_1^{-1}M_{12}]^{-1}\bar{v}(\cdot) \\ & \quad - [M_{12}^*(M_1^{-1})^*N_2M_1^{-1}M_{13} - N_{12}M_1^{-1}M_{13} - M_{12}^*(M_1^{-1})^*N_{13} + N_{13}](\xi). \end{aligned} \quad (33)$$

3.2.2 Hamiltonian system representation

Note that the representation (31) is quite abstract. Therefore, similar to Section 3.1.2, we can establish a FBSDE representation of Stackelberg equilibrium $(\bar{v}(\cdot), \bar{u}(\cdot))$ as follows:

Proposition 10 *Under (H1)-(H2), assume $M_1 \gg 0$ and $M_2 \geq 0$. Moreover, suppose $R_{J,1}(\cdot), R_{K,2}(\cdot)$ are invertible and $R_{J,1}(\cdot) \in L^\infty(t, T; \mathbb{S}^{m_1}), R_{K,2}(\cdot) \in L^\infty(t, T; \mathbb{S}^{m_2})$, for Problem (SG), the Stackelberg equilibrium (31) can be formulated as*

$$\bar{u} = -R_{J,1}^{-1}(B_1^\top \bar{y} + D_1^\top \bar{z}), \quad \bar{v} = -R_{K,2}^{-1}(B_2^\top \bar{\phi} + D_2^\top \bar{\theta}), \quad (34)$$

where

$$\begin{cases} d\bar{x} = [A\bar{x} - \widehat{B}_1\bar{y} - \widehat{F}_1\bar{z} - \widehat{B}_2\bar{\phi} - \widehat{D}_2\bar{\theta}]ds + [C\bar{x} - \widehat{D}_1\bar{y} - \widehat{F}_2\bar{z} - \widehat{D}_2^\top\bar{\phi} - \widehat{D}_3\bar{\theta}]dW(s), \\ d\bar{y} = [-A^\top\bar{y} - C^\top\bar{z} - Q_1\bar{x}]ds + \bar{z}dW(s), \\ d\bar{\phi} = [-A^\top\bar{\phi} - C^\top\bar{\theta} - Q_1\bar{\varphi} - Q_2\bar{x}]dt + \bar{\theta}dW(s), \\ d\bar{\varphi} = [A\bar{\varphi} - \widehat{B}_1\bar{\phi} - \widehat{D}_1^\top\bar{\theta} + \widehat{H}_1\bar{y} + \widehat{H}_2\bar{z}]dt + [C\bar{\varphi} - \widehat{F}_1^\top\bar{\phi} - \widehat{F}_2\bar{\theta} + \widehat{H}_3\bar{z} + \widehat{H}_2^\top\bar{y}]dW(s), \\ \bar{x}(t) = \xi, \quad \bar{y}(T) = G_1\bar{x}(T), \quad \bar{\phi}(T) = G_2\bar{x}(T) + G_1\bar{\varphi}(T), \quad \bar{\varphi}(t) = 0, \end{cases} \quad (35)$$

with

$$\widehat{F}_1 = B_1R_{J,1}^{-1}D_1^\top, \widehat{H}_1 = B_1R_{J,1}^{-1}R_{K,1}R_{J,1}^{-1}B_1^\top, \widehat{H}_2 = B_1R_{J,1}^{-1}R_{K,1}R_{J,1}^{-1}D_1^\top, \widehat{H}_3 = D_1R_{J,1}^{-1}R_{K,1}R_{J,1}^{-1}D_1^\top. \quad (36)$$

Moreover, the optimal cost functionals of \mathcal{A}_F and \mathcal{A}_L become

$$J(t, \xi; \bar{u}, \bar{v}) = \mathbb{E} \left\{ \int_t^T \langle R_{J,2}R_{K,2}^{-1}(B_2^\top\bar{\phi} + D_2^\top\bar{\theta}) - B_2^\top\bar{y} - D_2^\top\bar{z}, R_{K,2}^{-1}(B_2^\top\bar{\phi} + D_2^\top\bar{\theta}) \rangle ds + \langle \bar{x}(t), \bar{y}(t) \rangle \right\},$$

$$K(t, \xi; \bar{u}, \bar{v}) = \mathbb{E} \langle \bar{x}(t), \bar{\phi}(t) \rangle.$$

For the special case (SG₀), i.e., $J(t, \xi; u(\cdot), v(\cdot)) + K(t, \xi; u(\cdot), v(\cdot)) = 0$, we have

$$\begin{cases} \widehat{B}_1 = B_1R_{J,1}^{-1}B_1^\top, \widehat{B}_2 = -B_2R_{J,2}^{-1}B_2^\top, \widehat{D}_1 = D_1R_{J,1}^{-1}B_1^\top, \widehat{D}_2 = -B_2R_{J,2}^{-1}D_2^\top, \\ \widehat{D}_3 = -D_2R_{J,2}^{-1}D_2^\top, \widehat{F}_1 = \widehat{D}_1^\top, \widehat{F}_2 = D_1R_{J,1}^{-1}D_1^\top, \widehat{H}_1 = -\widehat{B}_1, \widehat{H}_2 = -\widehat{F}_1, \widehat{H}_3 = -\widehat{F}_2. \end{cases} \quad (37)$$

Therefore, (35) becomes

$$\begin{cases} d\bar{x} = [A\bar{x} - \widehat{B}_1\bar{y} - \widehat{F}_1\bar{z} - \widehat{B}_2\bar{\phi} - \widehat{D}_2\bar{\theta}]ds + [C\bar{x} - \widehat{D}_1\bar{y} - \widehat{F}_2\bar{z} - \widehat{D}_2^\top\bar{\phi} - \widehat{D}_3\bar{\theta}]dW(s), \\ d\bar{y} = [-A^\top\bar{y} - C^\top\bar{z} - Q_1\bar{x}]ds + \bar{z}dW(s), \\ d\bar{\phi} = [-A^\top\bar{\phi} - C^\top\bar{\theta} - Q_1\bar{\varphi} + Q_1\bar{x}]ds + \bar{\theta}dW(s), \\ d\bar{\varphi} = [A\bar{\varphi} - \widehat{B}_1(\bar{y} + \bar{\phi}) - \widehat{F}_1(\bar{z} + \bar{\theta})]ds + [C\bar{\varphi} - \widehat{D}_1(\bar{y} + \bar{\phi}) - \widehat{F}_2(\bar{z} + \bar{\theta})]dW(s), \\ \bar{x}(t) = \xi, \quad \bar{y}(T) = G_1\bar{x}(T), \quad \bar{\phi}(T) = -G_1\bar{x}(T) + G_1\bar{\varphi}(T), \quad \bar{\varphi}(t) = 0. \end{cases} \quad (38)$$

Moreover, we have

$$\begin{cases} d(\bar{y} + \bar{\phi}) = [-A^\top(\bar{y} + \bar{\phi}) - C^\top(\bar{z} + \bar{\theta}) - Q_1\bar{\varphi}]ds + (\bar{z} + \bar{\theta})dW(s), \\ \bar{y}(T) + \bar{\phi}(T) = G_1\bar{\varphi}(T). \end{cases}$$

Note that the states of $\bar{y} + \bar{\phi}$ and $\bar{\varphi}$ are linear homogeneous and $\bar{\varphi}(t) = 0$, by the standard estimations of SDE and BSDE, we have

$$\bar{\varphi}(s) = \bar{y}(s) + \bar{\phi}(s) = \bar{z}(s) + \bar{\theta}(s) = 0, \quad s \in [t, T].$$

Hence we have the following result.

Proposition 11 Under (H1)-(H2), assume $M_1 \gg 0$ and $M_2 \geq 0$. Moreover, suppose $R_{J,1}(\cdot), R_{J,2}(\cdot)$ are invertible and $R_{J,1}(\cdot) \in L^\infty(t, T; \mathbb{S}^{m_1}), R_{J,2}(\cdot) \in L^\infty(t, T; \mathbb{S}^{m_2})$, for Problem (SG₀), the Stackelberg equilibrium (31) can be formulated as

$$\bar{u} = -R_{J,1}^{-1}(B_1^\top \bar{y} + D_1^\top \bar{z}), \quad \bar{v} = -R_{J,2}^{-1}(B_2^\top \bar{y} + D_2^\top \bar{z}), \quad (39)$$

where

$$\begin{cases} d\bar{x} = [A\bar{x} - (\hat{B}_1 - \hat{B}_2)\bar{y} - (\hat{F}_1 - \hat{D}_2)\bar{z}]ds + [C\bar{x} - (\hat{D}_1 - \hat{D}_2^\top)\bar{y} - (\hat{F}_2 - \hat{D}_3)\bar{z}]dW(s), \\ d\bar{y} = [-A^\top \bar{y} - C^\top \bar{z} - Q_1 \bar{x}]ds + \bar{z}dW(s), \\ \bar{x}(t) = \xi, \quad \bar{y}(T) = G_1 \bar{x}(T). \end{cases} \quad (40)$$

Moreover, the optimal cost functionals of \mathcal{A}_F and \mathcal{A}_L become

$$J(t, \xi; \bar{u}, \bar{v}) = \mathbb{E}\langle \bar{x}(t), \bar{y}(t) \rangle = -K(t, \xi; \bar{u}, \bar{v}).$$

3.2.3 Riccati equation representation

The above open-loop Stackelberg equilibrium (39) is not satisfying, thus we will establish the Riccati equation representation in this section. Recall that [26] derived stochastic Riccati equations for the follower and the leader sequentially while the state feedback representation of the Stackelberg solution is obtained simultaneously for the leader and the follower in [4]. Since we take the follower's Hamiltonian system as the leader's controlled state equation, hence similar to [4], the Riccati equations for the follower and the leader are derived simultaneously. First, set

$$\begin{cases} \mathcal{X} = \begin{pmatrix} \bar{x} \\ \bar{\varphi} \end{pmatrix}, \quad \mathcal{Y} = \begin{pmatrix} \bar{\phi} \\ \bar{y} \end{pmatrix}, \quad \mathcal{Z} = \begin{pmatrix} \bar{\theta} \\ \bar{z} \end{pmatrix}, \quad \zeta = \begin{pmatrix} \xi \\ 0 \end{pmatrix}, \\ \mathcal{A} = \begin{pmatrix} A & 0 \\ 0 & A \end{pmatrix}, \quad \mathcal{B} = \begin{pmatrix} -\hat{B}_2 & -\hat{B}_1 \\ -\hat{B}_1 & \hat{H}_1^\top \end{pmatrix}, \quad \mathcal{D} = \begin{pmatrix} -\hat{D}_2 & -\hat{F}_1 \\ -\hat{D}_1^\top & \hat{H}_2 \end{pmatrix}, \quad \mathcal{C} = \begin{pmatrix} C & 0 \\ 0 & C \end{pmatrix}, \\ \mathcal{F} = \begin{pmatrix} -\hat{D}_2^\top & -\hat{D}_1 \end{pmatrix}, \quad \mathcal{H} = \begin{pmatrix} -\hat{D}_3 & -\hat{F}_2 \\ -\hat{F}_2 & \hat{H}_3 \end{pmatrix}, \quad \mathcal{Q} = \begin{pmatrix} Q_2 & Q_1 \\ Q_1 & 0 \end{pmatrix}, \quad \mathcal{G} = \begin{pmatrix} G_2 & G_1 \\ G_1 & 0 \end{pmatrix}. \end{cases} \quad (41)$$

Therefore, (35) takes the following form:

$$\begin{cases} d\mathcal{X} = [\mathcal{A}\mathcal{X} + \mathcal{B}\mathcal{Y} + \mathcal{D}\mathcal{Z}]ds + [\mathcal{C}\mathcal{X} + \mathcal{F}\mathcal{Y} + \mathcal{H}\mathcal{Z}]dW, \\ d\mathcal{Y} = -[\mathcal{Q}\mathcal{X} + \mathcal{A}^\top \mathcal{Y} + \mathcal{C}^\top \mathcal{Z}]ds + \mathcal{Z}dW, \\ \mathcal{X}(t) = \zeta, \quad \mathcal{Y}(T) = \mathcal{G}\mathcal{X}(T). \end{cases} \quad (42)$$

Introduce the following Riccati equation

$$\begin{cases} \dot{P} + \mathcal{Q} + \mathcal{A}^\top P + PA + P\mathcal{B}P + \mathcal{C}^\top (I - P\mathcal{H})^{-1} PC + \mathcal{C}^\top (I - P\mathcal{H})^{-1} P\mathcal{F}P \\ + PD(I - P\mathcal{H})^{-1} PC + PD(I - P\mathcal{H})^{-1} P\mathcal{F}P = 0, \\ P(T) = \mathcal{G}, \\ \det[I - P\mathcal{H}] \neq 0, \end{cases} \quad (43)$$

we have

$$\mathcal{Y} = P\mathcal{X}, \quad \mathcal{Z} = (I - P\mathcal{H})^{-1} [PC + P\mathcal{F}P]\mathcal{X}. \quad (44)$$

Therefore, the Stackelberg equilibrium takes the following ‘‘closed-loop’’ representation:

$$\begin{pmatrix} \bar{u} \\ \bar{v} \end{pmatrix} = - \left[\begin{pmatrix} R_{J,1}^{-1} B_1^\top & 0 \\ 0 & R_{K,2}^{-1} B_2^\top \end{pmatrix} P + \begin{pmatrix} R_{J,1}^{-1} B_1^\top & 0 \\ 0 & R_{K,2}^{-1} B_2^\top \end{pmatrix} (I - P\mathcal{H})^{-1} (PC + P\mathcal{F}P) \right] \mathcal{X} \triangleq \Lambda \mathcal{X}.$$

Let $R_1(s) = \begin{pmatrix} R_{J,1}(s) & 0 \\ 0 & R_{J,2}(s) \end{pmatrix}$, then

$$J(t, \xi; \bar{u}, \bar{v}) = \mathbb{E} \left\{ \int_t^T \langle \mathcal{Q}_1(s) \mathcal{X}(s), \mathcal{X}(s) \rangle ds + \langle \mathcal{G}_1 \mathcal{X}(T), \mathcal{X}(T) \rangle \right\},$$

where

$$\mathcal{Q}_1 = \begin{pmatrix} Q_1 & 0 \\ 0 & 0 \end{pmatrix} + \Lambda^\top R_1 \Lambda, \quad \mathcal{G}_1 = \begin{pmatrix} G_1 & 0 \\ 0 & 0 \end{pmatrix}.$$

Plugging (44) into (42), we have

$$d\mathcal{X} = \mathbb{A}\mathcal{X}dt + \mathbb{B}\mathcal{X}dW, \quad \mathcal{X}(t) = \zeta,$$

where,

$$\mathbb{A} = \mathcal{A} + \mathcal{B}P + \mathcal{D}(I - P\mathcal{H})^{-1} [PC + P\mathcal{F}P], \quad \mathbb{B} = \mathcal{C} + \mathcal{F}P + \mathcal{H}(I - P\mathcal{H})^{-1} [PC + P\mathcal{F}P].$$

Finally, introduce the following Riccati equation,

$$\dot{\hat{P}} + \hat{P}\mathbb{A} + \mathbb{A}^\top \hat{P} + \mathbb{B}^\top \hat{P}\mathbb{B} + \mathcal{Q}_1 = 0, \quad \hat{P}(T) = \mathcal{G}_1, \quad (45)$$

we have the optimal functional for \mathcal{A}_F as follows:

$$J(t, \xi; \bar{u}, \bar{v}) = \mathbb{E} \langle \hat{P}_1(t) \xi, \xi \rangle,$$

where $\hat{P} = \begin{pmatrix} \hat{P}_1 & \hat{P}_2 \\ \hat{P}_3 & \hat{P}_4 \end{pmatrix}$. Similarly, the optimal functional for \mathcal{A}_L is as follows:

$$K(t, \xi; \bar{u}, \bar{v}) = \mathbb{E} \langle \tilde{P}_1(t) \xi, \xi \rangle,$$

where $\tilde{P} = \begin{pmatrix} \tilde{P}_1 & \tilde{P}_2 \\ \tilde{P}_3 & \tilde{P}_4 \end{pmatrix}$ is the solution of the following Riccati equation

$$\dot{\tilde{P}} + \tilde{P}\mathbb{A} + \mathbb{A}^\top \tilde{P} + \mathbb{B}^\top \tilde{P}\mathbb{B} + \mathcal{Q}_2 = 0, \quad \tilde{P}(T) = \mathcal{G}_2, \quad (46)$$

with

$$\mathcal{Q}_2 = \begin{pmatrix} Q_2 & 0 \\ 0 & 0 \end{pmatrix} + \Lambda^\top R_2 \Lambda, \quad R_2 = \begin{pmatrix} R_{K,1} & 0 \\ 0 & R_{K,2} \end{pmatrix}, \quad \mathcal{G}_2 = \begin{pmatrix} G_2 & 0 \\ 0 & 0 \end{pmatrix}.$$

Proposition 12 *Suppose that equations (43), (45) and (46) admit solutions such that $I - P\mathcal{H}$ is invertible, then the Stackelberg equilibrium (39) of (SG) has the following representation:*

$$\begin{pmatrix} \bar{u} \\ \bar{v} \end{pmatrix} = - \left[\begin{pmatrix} R_{J,1}^{-1} B_1^\top & 0 \\ 0 & R_{K,2}^{-1} B_2^\top \end{pmatrix} P + \begin{pmatrix} R_{J,1}^{-1} B_1^\top & 0 \\ 0 & R_{K,2}^{-1} B_2^\top \end{pmatrix} (I - P\mathcal{H})^{-1} (PC + P\mathcal{F}P) \right] \mathcal{X}.$$

Furthermore, the optimal costs take the following form:

$$J(t, \xi; \bar{u}, \bar{v}) = \mathbb{E} \langle \hat{P}_1(t) \xi, \xi \rangle, \quad K(t, \xi; \bar{u}, \bar{v}) = \mathbb{E} \langle \tilde{P}_1(t) \xi, \xi \rangle,$$

where \hat{P} and \tilde{P} are the solutions of (45) and (46) respectively.

For (SG₀), since $\bar{\varphi}(s) = \bar{y}(s) + \bar{\phi}(s) = \bar{z}(s) + \bar{\theta}(s) = 0$, Hamiltonian system (40) is the same as that of (NG₀), i.e., (21). Therefore, we have the following result.

Proposition 13 *For (SG₀), suppose that equations (22) and (26) admit solutions such that $I + \Pi_1(\widehat{F}_2 - \widehat{D}_3)$ is invertible, then the Stackelberg equilibrium has the following representation:*

$$\begin{cases} \bar{u}(s) = -R_{j,1}^{-1}(B_1^\top \Pi_1 + D_1^\top (I + \Pi_1(\widehat{F}_2 - \widehat{D}_3))^{-1}(\Pi_1 C - \Pi_1(\widehat{D}_1 - \widehat{D}_2^\top)\Pi_1))\bar{x}, \\ \bar{v}(s) = -R_{j,2}^{-1}(B_2^\top \Pi_1 + D_2^\top (I + \Pi_1(\widehat{F}_2 - \widehat{D}_3))^{-1}(\Pi_1 C - \Pi_1(\widehat{D}_1 - \widehat{D}_2^\top)\Pi_1))\bar{x}. \end{cases}$$

Furthermore, the optimal costs become

$$J(t, \xi; \bar{u}, \bar{v}) = \mathbb{E}\langle \widehat{p}_2^{(1)}(t)\xi, \xi \rangle = -K(t, \xi; \bar{u}, \bar{v}),$$

where \widehat{p}_2 is the solution of (26).

3.2.4 Time-inconsistency of SG, SG₀

For any $(t, \xi) \in (0, T) \times L_{\mathcal{F}_t}^2(\Omega; \mathbb{R}^n)$, consider the following Hamiltonian system on $[t, T]$,

$$\begin{cases} d\bar{x} = [A\bar{x} - \widehat{B}_1\bar{y} - \widehat{F}_1\bar{z} - \widehat{B}_2\bar{\phi} - \widehat{D}_2\bar{\theta}]ds + [C\bar{x} - \widehat{D}_1\bar{y} - \widehat{F}_2\bar{z} - \widehat{D}_2^\top\bar{\phi} - \widehat{D}_3\bar{\theta}]dW(s), \\ d\bar{y} = [-A^\top\bar{y} - C^\top\bar{z} - Q_1\bar{x}]ds + \bar{z}dW(s), \\ d\bar{\phi} = [-A^\top\bar{\phi} - C^\top\bar{\theta} - Q_1\bar{\varphi} + Q_1\bar{x}]ds + \bar{\theta}dW(s), \\ d\bar{\varphi} = [A\bar{\varphi} - \widehat{B}_1(\bar{y} + \bar{\phi}) - \widehat{F}_1(\bar{z} + \bar{\theta})]ds + [C\bar{\varphi} - \widehat{D}_1(\bar{y} + \bar{\phi}) - \widehat{F}_2(\bar{z} + \bar{\theta})]dW(s), \\ \bar{x}(t) = \xi, \quad \bar{y}(T) = G_1\bar{x}(T), \quad \bar{\phi}(T) = -G_1\bar{x}(T) + G_1\bar{\varphi}(T), \quad \bar{\varphi}(t) = 0. \end{cases} \quad (47)$$

Let $\bar{x}(s'; t, \xi, 0, T, G_1, G_2)$ denote the solution of (30) at $s' \in [t, T]$. For $(s', \bar{x}(s'; t, \xi, 0, T, G_1, G_2)) \in (t, T) \times L_{\mathcal{F}_{s'}}^2(\Omega; \mathbb{R}^n)$, consider Hamiltonian system (47) on $[s', T]$ with $\bar{x}(s') = \bar{x}(s'; t, \xi, 0, T, G_1, G_2)$, $\bar{\varphi}(s') = 0$. In general, since $\bar{\varphi}(s') = 0$ and $\bar{\varphi}(s'; t, \xi, 0, T, G_1, G_2) \neq 0$, we have

$$\bar{x}(s; t, \xi, 0, T, G_1, G_2) \neq \bar{x}(s; s', \bar{x}(s'; t, \xi, 0, T, G_1, G_2)), \quad t \leq s' \leq s \leq T.$$

Therefore, following Definition 2, we get that FBSDE (47) is time-inconsistent. Or in other words, open-loop Stackelberg equilibrium of (SG) is time-inconsistent.

For (SG), we may also introduce the following operators. For any $(t, \xi) \in (0, T) \times L_{\mathcal{F}_t}^2(\Omega; \mathbb{R}^n)$, define $\mathbb{T} \cdot (t, \xi) := (\bar{x}(\cdot), \bar{y}(\cdot), \bar{z}(\cdot), \bar{\phi}(\cdot), \bar{\theta}(\cdot), \bar{\varphi}(\cdot))|_{[t, T]}$ for the Hamiltonian system (35) defined on $[t, T]$ with initials (t, ξ) . Note that $\bar{\varphi}(t) = 0$, that is, Hamiltonian system operator for φ at initial time is always 0. Therefore, in general it does not satisfy the semigroup property

$$\mathbb{T}_s(t, x) = \mathbb{T}_s(s', \mathbb{T}_{s'}(t, x)), \quad 0 < t < s' < s < T, x \in L_{\mathcal{F}_t}^2(\Omega; \mathbb{R}^n). \quad (48)$$

Furthermore, for (SG₀), since $\bar{\varphi}(s) \equiv 0$, hence the semigroup property (48) hold. That is, (SG₀) is still time consistent.

4 Stackelberg game with local information

4.1 Stackelberg game with local information

First, Stackelberg game with global information can be represented by the following figure.



FIG. 2. Global information: the whole decision horizon $[0, T]$ is covered by a single arrow (aka arrow ① depicted in Fig. 1). It means that leader will announce, at initial time, his decision commitment on whole horizon in global manner. As such, the “6” scheme can be readily applied to current classical case.

In many real problems, at the initial time the leader may not announce his strategy on the whole time interval. Hence we introduce Stackelberg game with local information as follows.

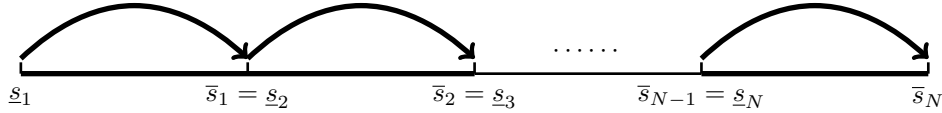

FIG. 3. Local information: the whole horizon is still covered but jointly by a variety of disjoint arrows, instead single one. These arrows are of distinct left-starting and right-ending points. A sequence of non-overlap sub-intervals thereby arise and leader releases his commitment merely within each sub-interval locally. Therefore, at any time, follower can only access forthcoming decision of leader in pertinent sub-interval lacking global information. Thus, unlike arrow ② in Fig. 1, follower cannot decide his best response only upon such local prior knowledge. As such, classical “6” scheme fails to work.

Finally, we will introduce mixed information pattern which includes global- and local-information.

Definition 3 A Stackelberg duration partition index on $[0, T]$ is defined to be $\mathcal{S} \triangleq \{\mathcal{S}_i\}_{i=1}^N$, where for $i = 1, \dots, N$, $\mathcal{S}_i \triangleq [s_i, \bar{s}_i)$ with $0 = \underline{t}_1 \leq \bar{t}_1 = \underline{s}_1 \leq \bar{s}_1 = \underline{t}_2 \leq \bar{t}_2 = \underline{s}_2 \leq \bar{s}_2 \leq \dots \leq \underline{t}_N \leq \bar{t}_N = \underline{s}_N \leq \bar{s}_N = T$, $\mathcal{T}_i \triangleq [t_i, \bar{t}_i]$ and $\bigcup_{i=1}^N \mathcal{S}_i = [0, T] \setminus \bigcup_{i=1}^N \mathcal{T}_i$. N is called Stackelberg announce frequency. On each \mathcal{S}_i , the leader will announce his committed strategy $v(\cdot)|_{\mathcal{S}_i}$ at the moment s_i . A Stackelberg duration partition index on $[t, T]$ can be defined similarly.



FIG. 4. Mixed information: there exist multiple arrows along which leader pre-commits his forthcoming decisions. However, their union only covers a subset of whole horizon $[0, T]$ and no commitment made on remaining part. In fact, on *dashed* sub-intervals, both leader and follower have no prior knowledge in either commitment or best response, so they must play a Nash type strategy within these sub-intervals. As a result, some (Stackelberg and Nash) mixed decision is induced on whole horizon in coupling.

In case $N = 1$, $s_1 = 0$ and $\bar{s}_1 = T$, Stackelberg game with duration index $\{\mathcal{S}_i\}_{i=1}^N$ reduces to global information case (SG) in Section 3.2. For $N > 1$ and $\mathcal{S} = [0, T]$, Stackelberg game with duration index $\{\mathcal{S}_i\}_{i=1}^N$ reduces to Stackelberg game with local information (SL). For simplicity, for (SL) we use s_i instead of \underline{s}_i . In this case $[0, T] = \bigcup_{i=1}^N \mathcal{S}_i = \bigcup_{i=1}^N [s_{i-1}, s_i]$.

4.2 A repeated game principle

For (SL), at the initial time the leader will not announce his strategy on the whole time interval, hence instead of finding optimal strategies for leader and follower on the whole time horizon, we would like to find some kind of locally optimal strategies or equilibrium strategies. Similar to Yong [25], we introduce the following definition in spirit of backward recursion.

Definition 4 For any $i = 1, \dots, N$, $\xi \in \mathbb{R}^n$ and any $(u_i(\cdot), v_i(\cdot)) \in \mathcal{U}([s_{i-1}, s_i]) \times \mathcal{V}([s_{i-1}, s_i])$, $\{\bar{\alpha}_i : \mathcal{V}([s_{i-1}, s_i]) \times \mathbb{R}^n \rightarrow \mathcal{U}([s_{i-1}, s_i])\}_{i=1}^N$ is a Stackelberg equilibrium of (SL) if

$$\begin{cases} J(s_{i-1}, \xi; \bar{\alpha}_i(v_i, \xi) \oplus \bar{\alpha}_{i+1}(\bar{v}_{i+1}, x^{\bar{\alpha}_i, v_i}(s_i)) \oplus \dots \oplus \bar{\alpha}_N(\bar{v}_N, x^{\bar{\alpha}_i, v_i}(s_{N-1})), v_i \oplus \bar{v}_{i+1} \oplus \dots \oplus \bar{v}_N) \\ \leq J(s_{i-1}, \xi; u_i \oplus \bar{\alpha}_{i+1}(\bar{v}_{i+1}, x^{u_i, v_i}(s_i)) \oplus \dots \oplus \bar{\alpha}_N(\bar{v}_N, x^{u_i, v_i}(s_{N-1})), v_i \oplus \bar{v}_{i+1} \oplus \dots \oplus \bar{v}_N), \\ K(s_{i-1}, \xi; \bar{\alpha}_i(\bar{v}_i, \xi) \oplus \bar{\alpha}_{i+1}(\bar{v}_{i+1}, x^{\bar{\alpha}_i, \bar{v}_i}(s_i)) \oplus \dots \oplus \bar{\alpha}_N(\bar{v}_N, x^{\bar{\alpha}_i, \bar{v}_i}(s_{N-1})), \bar{v}_i \oplus \bar{v}_{i+1} \oplus \dots \oplus \bar{v}_N) \\ \leq K(s_{i-1}, \xi; \bar{\alpha}_i(v_i, \xi) \oplus \bar{\alpha}_{i+1}(\bar{v}_{i+1}, x^{\bar{\alpha}_i, v_i}(s_i)) \oplus \dots \oplus \bar{\alpha}_N(\bar{v}_N, x^{\bar{\alpha}_i, v_i}(s_{N-1})), v_i \oplus \bar{v}_{i+1} \oplus \dots \oplus \bar{v}_N), \end{cases}$$

where $x^{\bar{\alpha}_i, v_i}$ is the solution of (1) on $[s_{i-1}, s_N]$ with respect to

$$(\bar{\alpha}_i(v_i, \xi) \oplus \bar{\alpha}_{i+1}(\bar{v}_{i+1}, x^{\bar{\alpha}_i, v_i}(s_i)) \oplus \dots \oplus \bar{\alpha}_N(\bar{v}_N, x^{\bar{\alpha}_i, v_i}(s_N)), v_i \oplus \bar{v}_{i+1} \oplus \dots \oplus \bar{v}_N),$$

x^{u_i, v_i} is the solution of (1) on $[s_{i-1}, s_N]$ with respect to

$$(u_i \oplus \bar{\alpha}_{i+1}(\bar{v}_{i+1}, x^{u_i, v_i}(s_{i+1})) \oplus \dots \oplus \bar{\alpha}_N(\bar{v}_N, x^{u_i, v_i}(s_N)), v_i \oplus \bar{v}_{i+1} \oplus \dots \oplus \bar{v}_N)$$

and $x^{\bar{\alpha}_i, \bar{v}_i}$ is the solution of (1) on $[s_{i-1}, s_N]$ with respect to

$$(\bar{\alpha}_i(\bar{v}_i, \xi) \oplus \bar{\alpha}_{i+1}(\bar{v}_{i+1}, x^{\bar{\alpha}_i, \bar{v}_i}(s_i)) \oplus \dots \oplus \bar{\alpha}_N(\bar{v}_N, x^{\bar{\alpha}_i, \bar{v}_i}(s_N)), \bar{v}_i \oplus \bar{v}_{i+1} \oplus \dots \oplus \bar{v}_N).$$

Proposition 14 If (SL) admits a Stackelberg equilibrium $(\bar{\alpha}_i(\cdot), \bar{v}_i(\cdot))_{i=1}^N$ on $[0, T]$, then $(\bar{\alpha}_i(\cdot), \bar{v}_i(\cdot))$ is a Stackelberg equilibrium of (SG) $_{\mathcal{S}_i}$. In summary,

$$(repeated\ game\ principle): \quad (SL)_{[0, T]} = (SG)_{\mathcal{S}_N} \oplus (SG)_{\mathcal{S}_{N-1}} \oplus \dots \oplus (SG)_{\mathcal{S}_1}.$$

where (SG) $_{\mathcal{S}_i}$ is a Stackelberg game with global information on \mathcal{S}_i with the following cost functionals

$$\begin{aligned} J(s_{i-1}, x(s_{i-1}); u(\cdot), v(\cdot)) = \mathbb{E} \left\{ \int_{s_{i-1}}^{s_i} \left[\langle Q_1(s)x(s), x(s) \rangle + \langle R_{J,1}(s)u(s), u(s) \rangle + \langle R_{J,2}(s)v(s), v(s) \rangle \right] ds \right. \\ \left. + \langle G_{1,i}, x(s_i), x(s_i) \rangle \right\}. \end{aligned}$$

and

$$\begin{aligned} J(s_{i-1}, x(s_{i-1}); u(\cdot), v(\cdot)) = \mathbb{E} \left\{ \int_{s_{i-1}}^{s_i} \left[\langle Q_2(s)x(s), x(s) \rangle + \langle R_{K,1}(s)u(s), u(s) \rangle + \langle R_{K,2}(s)v(s), v(s) \rangle \right] ds \right. \\ \left. + \langle G_{2,i}, x(s_i), x(s_i) \rangle \right\}. \end{aligned}$$

Note that $G_{1,i}$ and $G_{2,i}$ are some unspecified terms which will be determined by the backward procedure in the following section.

4.3 Backward procedure

4.3.1 (SL)| \mathcal{S}_N

Let us start with (SL) on \mathcal{S}_N . To this end, consider the following state equation and cost functionals

$$\begin{cases} dx(s) = [A(s)x(s) + B_1(s)u(s) + B_2(s)v(s)]ds + [C(s)x(s) + D_1(s)u(s) + D_2(s)v(s)]dW(s), \\ x(s_{N-1}) = \xi_{N-1}, \end{cases} \quad (49)$$

and

$$\begin{cases} J(s_{N-1}, \xi_{N-1}; u(\cdot), v(\cdot)) = \mathbb{E} \left\{ \int_{s_{N-1}}^{s_N} \left[\langle Q_1(s)x(s), x(s) \rangle + \langle R_{J,1}(s)u(s), u(s) \rangle + \langle R_{J,2}(s)v(s), v(s) \rangle \right] ds \right. \\ \quad \left. + \langle G_1x(s_N), x(s_N) \rangle \right\}, \\ K(s_{N-1}, \xi_{N-1}; u(\cdot), v(\cdot)) = \mathbb{E} \left\{ \int_{s_{N-1}}^{s_N} \left[\langle Q_2(s)x(s), x(s) \rangle + \langle R_{K,1}(s)u(s), u(s) \rangle + \langle R_{K,2}(s)v(s), v(s) \rangle \right] ds \right. \\ \quad \left. + \langle G_2x(s_N), x(s_N) \rangle \right\}. \end{cases}$$

In (49), (s_{N-1}, ξ_{N-1}) is the initial time and initial state (also called initial pair) on \mathcal{S}_N which will be taken as the terminal time and terminal state (also called terminal pair) on \mathcal{S}_{N-1} . On \mathcal{S}_N , (SL) (or (SL)| \mathcal{S}_N) is a standard Stackelberg game. Therefore, similar to (SG), we have the open-loop Stackelberg equilibrium on \mathcal{S}_N

$$\bar{u}_N = -R_{J,1}^{-1}(B_1^\top y + D_1^\top z), \quad \bar{v}_N = -R_{K,2}^{-1}(B_2^\top \phi_N + D_2^\top \theta_N), \quad (50)$$

for (SL) $_{\mathcal{S}_N}$ through the following Hamilton system:

$$\begin{cases} dx = [Ax - \hat{B}_1y - \hat{F}_1z - \hat{B}_2\phi_N - \hat{D}_2\theta_N]ds + [Cx - \hat{D}_1y - \hat{F}_2z - \hat{D}_2^\top\phi_N - \hat{D}_3^\top\theta_N]dW(s), \\ dy = [-A^\top y - C^\top z - Q_1x]ds + zdW(s), \\ d\phi_N = [-A^\top\phi_N - C^\top\theta_N - Q_1\phi_N - Q_2x]dt + \theta_N dW(s), \\ d\varphi_N = [-\hat{B}_1^\top\phi_N - \hat{D}_1^\top\theta_N + A\varphi_N + \hat{H}_1y + \hat{H}_2z]dt + [-\hat{F}_1^\top\phi_N - \hat{F}_2^\top\theta_N + C\varphi_N + \hat{H}_3z + \hat{H}_2^\top y]dW(s), \\ x(s_{N-1}) = \xi_{N-1}, \quad y(s_N) = G_1x(s_N), \quad \phi_N(s_N) = G_2x(s_N) + G_1\varphi_N(s_N), \quad \varphi_N(s_{N-1}) = 0, \end{cases} \quad (51)$$

where $\xi_{N-1} \in L^2_{\mathcal{F}_{s_{N-1}}}(\mathbb{R}^n)$ and the coefficients are defined in (37). In the following we will give the Riccati equation representation. Set

$$\begin{cases} X = \begin{pmatrix} x \\ \varphi_N \end{pmatrix}, \quad Y = \begin{pmatrix} \phi_N \\ y \end{pmatrix}, \quad Z = \begin{pmatrix} \theta_N \\ z \end{pmatrix}, \quad \zeta_{N-1} = \begin{pmatrix} \xi_{N-1} \\ 0 \end{pmatrix}; \\ \mathcal{A} = \begin{pmatrix} A & 0 \\ 0 & A \end{pmatrix}, \quad \mathcal{B} = \begin{pmatrix} -\hat{B}_2 & -\hat{B}_1 \\ -\hat{B}_1 & \hat{H}_1^\top \end{pmatrix}, \quad \mathcal{D} = \begin{pmatrix} -\hat{D}_2 & -\hat{F}_1 \\ -\hat{D}_1^\top & \hat{H}_2 \end{pmatrix}, \quad \mathcal{C} = \begin{pmatrix} C & 0 \\ 0 & C \end{pmatrix}, \\ \mathcal{F} = \begin{pmatrix} -\hat{D}_2^\top & -\hat{D}_1 \end{pmatrix}, \quad \mathcal{H} = \begin{pmatrix} -\hat{D}_3 & -\hat{F}_2 \\ -\hat{F}_2 & \hat{H}_3 \end{pmatrix}, \quad \mathcal{Q} = \begin{pmatrix} Q_2 & Q_1 \\ Q_1 & 0 \end{pmatrix}, \quad \mathcal{G} = \begin{pmatrix} G_2 & G_1 \\ G_1 & 0 \end{pmatrix}. \end{cases} \quad (52)$$

Therefore, (51) takes the following form:

$$\begin{cases} dX = [\mathcal{A}X + \mathcal{B}Y + \mathcal{D}Z]ds + [\mathcal{C}X + \mathcal{F}Y + \mathcal{H}Z]dW, \\ dY = -[\mathcal{Q}X + \mathcal{A}^\top Y + \mathcal{C}^\top Z]ds + ZdW, \\ X(s_{N-1}) = \zeta_{N-1}, \quad Y(s_N) = \mathcal{G}X(s_N). \end{cases} \quad (53)$$

Introduce the following Riccati equation and BSDE

$$\begin{cases} \dot{P}^{(N)} + \mathcal{Q} + \mathcal{A}^\top P^{(N)} + P^{(N)}\mathcal{A} + P^{(N)}\mathcal{B}P^{(N)} + \mathcal{C}^\top(I - P^{(N)}\mathcal{H})^{-1}P^{(N)}\mathcal{C} \\ + \mathcal{C}^\top(I - P^{(N)}\mathcal{H})^{-1}P^{(N)}\mathcal{F}P^{(N)} + P^{(N)}\mathcal{D}(I - P^{(N)}\mathcal{H})^{-1}P^{(N)}\mathcal{C} \\ + P^{(N)}\mathcal{D}(I - P^{(N)}\mathcal{H})^{-1}P^{(N)}\mathcal{F}P^{(N)} = 0, \\ P^{(N)}(s_N) = \mathcal{G}, \\ \det[I - P^{(N)}\mathcal{H}] \neq 0, \end{cases} \quad (54)$$

we have

$$Y = P^{(N)}X, \quad Z = (I - P^{(N)}\mathcal{H})^{-1}[P^{(N)}\mathcal{C} + P^{(N)}\mathcal{F}P^{(N)}]X. \quad (55)$$

Therefore, the Stackelberg equilibrium takes the following ‘‘closed-loop’’ representation:

$$\begin{pmatrix} \bar{u}_N \\ \bar{v}_N \end{pmatrix} = - \left[\begin{pmatrix} R_{J,1}^{-1}B_1^\top & 0 \\ 0 & R_{K,2}^{-1}B_2^\top \end{pmatrix} P^{(N)} + \begin{pmatrix} R_{J,1}^{-1}B_1^\top & 0 \\ 0 & R_{K,2}^{-1}B_2^\top \end{pmatrix} (I - P^{(N)}\mathcal{H})^{-1}(P^{(N)}\mathcal{C} + P^{(N)}\mathcal{F}P^{(N)}) \right] X \\ \triangleq \mathbb{A}_N X. \quad (56)$$

Let $R_1(s) = \begin{pmatrix} R_{J,1}(s) & 0 \\ 0 & R_{J,2}(s) \end{pmatrix}$, then

$$J(s_{N-1}, \xi_{N-1}; \bar{u}_N, \bar{v}_N) = \mathbb{E} \left\{ \int_{s_N} \langle \mathcal{Q}_{1,N}(s)X(s), X(s) \rangle ds + \langle \mathcal{G}_1 X(T), X(T) \rangle \right\},$$

where

$$\mathcal{Q}_{1,N} = \begin{pmatrix} Q_1 & 0 \\ 0 & 0 \end{pmatrix} + \mathbb{A}_N^\top R_1 \mathbb{A}_N, \quad \mathcal{G}_{1,N} = \begin{pmatrix} G_1 & 0 \\ 0 & 0 \end{pmatrix}.$$

Plugging (55) into (53), we have

$$dX = \mathbb{A}_N X dt + \mathbb{B}_N X dW, \quad X(s_{N-1}) = \zeta_{N-1}, \quad (57)$$

where,

$$\begin{aligned} \mathbb{A}_N &= \mathcal{A} + \mathcal{B}P^{(N)} + \mathcal{D}(I - P^{(N)}\mathcal{H})^{-1}[P^{(N)}\mathcal{C} + P^{(N)}\mathcal{F}P^{(N)}], \\ \mathbb{B}_N &= \mathcal{C} + \mathcal{F}P^{(N)} + \mathcal{H}(I - P^{(N)}\mathcal{H})^{-1}[P^{(N)}\mathcal{C} + P^{(N)}\mathcal{F}P^{(N)}]. \end{aligned}$$

Finally, introduce the following Riccati equation,

$$\dot{\hat{P}}^{(N)} + \hat{P}^{(N)}\mathbb{A}_N + \mathbb{A}_N^\top \hat{P}^{(N)} + \mathbb{B}_N^\top \hat{P}^{(N)}\mathbb{B}_N + \mathcal{Q}_{1,N} = 0, \quad \hat{P}^{(N)}(s_N) = \mathcal{G}_{1,N}, \quad (58)$$

we have the optimal functional for \mathcal{A}_F as follows:

$$J(s_{N-1}, \xi_{N-1}; \bar{u}|_{s_N}, \bar{v}|_{s_N}) = \mathbb{E} \langle \hat{P}_1^{(N)}(s_{N-1})\xi_{N-1}, \xi_{N-1} \rangle,$$

where $\widehat{P}^{(N)} = \begin{pmatrix} \widehat{P}_1^{(N)} & \widehat{P}_2^{(N)} \\ \widehat{P}_3^{(N)} & \widehat{P}_4^{(N)} \end{pmatrix}$. Similarly, the optimal functional for \mathcal{A}_L is as follows:

$$K(s_{N-1}, \xi_{N-1}; \bar{u}|_{\mathcal{S}_N}, \bar{v}|_{\mathcal{S}_N}) = \mathbb{E}\langle \widetilde{P}_1^{(N)}(s_{N-1})\xi_{N-1}, \xi_{N-1} \rangle,$$

where $\widetilde{P}^{(N)} = \begin{pmatrix} \widetilde{P}_1^{(N)} & \widetilde{P}_2^{(N)} \\ \widetilde{P}_3^{(N)} & \widetilde{P}_4^{(N)} \end{pmatrix}$ is the solution of the following Riccati equation

$$\dot{\widetilde{P}}^{(N)} + \widetilde{P}^{(N)}\mathbb{A}_N + \mathbb{A}_N^\top \widetilde{P}^{(N)} + \mathbb{B}_N^\top \widetilde{P}^{(N)}\mathbb{B}_N + \mathcal{Q}_{2,N} = 0, \quad \widetilde{P}^{(N)}(s_N) = \mathcal{G}_{2,N}, \quad (59)$$

with

$$\mathcal{Q}_{2,N} = \begin{pmatrix} Q_2 & 0 \\ 0 & 0 \end{pmatrix} + \Lambda_N^\top R_2 \Lambda_N, \quad R_2 = \begin{pmatrix} R_{K,1}(s) & 0 \\ 0 & R_{K,2}(s) \end{pmatrix}, \quad \mathcal{G}_{2,N} = \begin{pmatrix} G_2 & 0 \\ 0 & 0 \end{pmatrix}.$$

Since $(\text{SL})|_{\mathcal{S}_N}$ is a standard Stackelberg game, the open-loop strategies (50) or the corresponding state feedback representations (56) obviously satisfy Definition 4 for $i = N$.

4.3.2 $(\text{SL})|_{\mathcal{S}_{N-1}}$

Next, we consider the Stackelberg game on \mathcal{S}_{N-1} , i.e., consider the following state equation and cost functionals

$$\begin{cases} dx(s) = [A(s)x(s) + B_1(s)u(s) + B_2(s)v(s)]ds + [C(s)x(s) + D_1(s)u(s) + D_2(s)v(s)]dW(s), \\ x(s_{N-2}) = \xi_{N-2}, \end{cases} \quad (60)$$

and

$$\begin{cases} J(s_{N-2}, \xi_{N-2}; u(\cdot), v(\cdot)) = \mathbb{E}\left\{ \int_{s_{N-2}}^{s_{N-1}} [\langle Q_1(s)x(s), x(s) \rangle + \langle R_{J,1}(s)u(s), u(s) \rangle + \langle R_{J,2}(s)v(s), v(s) \rangle] ds \right. \\ \quad \left. + \langle \widehat{P}_1^{(N)}(s_{N-1})x(s_{N-1}), x(s_{N-1}) \rangle \right\}, \\ K(s_{N-2}, \xi_{N-2}; u(\cdot), v(\cdot)) = \mathbb{E}\left\{ \int_{s_{N-2}}^{s_{N-1}} [\langle Q_2(s)x(s), x(s) \rangle + \langle R_{K,1}(s)u(s), u(s) \rangle + \langle R_{K,2}(s)v(s), v(s) \rangle] ds \right. \\ \quad \left. + \langle \widetilde{P}_1^{(N)}(s_{N-1})x(s_{N-1}), x(s_{N-1}) \rangle \right\}. \end{cases} \quad (61)$$

Remark 1 $(\text{SL})|_{\mathcal{S}_N}$ is a standard Stackelberg game and we have obtained the optimal strategies for leader and follower on $[s_{N-1}, s_N]$ based on the initial condition (s_{N-1}, ξ_{N-1}) , therefore we should expect that the state (60) (and equilibrium strategies) on \mathcal{S}_N coincide with the optimal state (57) (and equilibrium strategies) on \mathcal{S}_N . Hence the optimal state (57) starts from $(s_{N-1}, x(s_{N-1}))$, or in other words, the terminal pair $(s_{N-1}, x(s_{N-1}))$ on \mathcal{S}_{N-1} is the initial pair $(s_{N-1}, \bar{x}(s_{N-1}))$ on \mathcal{S}_N . Taking into account of this, the cost functional of follower on \mathcal{S}_{N-1}

becomes

$$\begin{aligned}
& J(s_{N-2}, \xi_{N-2}; u(\cdot), v(\cdot)) \\
&= \mathbb{E} \int_{s_{N-2}}^{s_{N-1}} \left[\langle Q_1(s)x(s), x(s) \rangle + \langle R_{J,1}(s)u(s), u(s) \rangle + \langle R_{J,2}(s)v(s), v(s) \rangle \right] ds \\
&\quad + \mathbb{E} \int_{s_{N-1}}^{s_N} \left[\langle Q_1(s)X(s), X(s) \rangle + \langle R_{J,1}(s)u(s), u(s) \rangle + \langle R_{J,2}(s)v(s), v(s) \rangle \right] ds + \mathbb{E} \langle G_1 X(s_N), X(s_N) \rangle \\
&= \mathbb{E} \int_{s_{N-2}}^{s_{N-1}} \left[\langle Q_1(s)x(s), x(s) \rangle + \langle R_{J,1}(s)u(s), u(s) \rangle + \langle R_{J,2}(s)v(s), v(s) \rangle \right] ds \\
&\quad + \mathbb{E} \left\langle \widehat{P}_N^{(1)}(s_{N-1})x(s_{N-1}), x(s_{N-1}) \right\rangle,
\end{aligned}$$

where $x(\cdot)$ is the solution of (60). This is the derivation of cost functionals (61).

(SL) $_{\mathcal{S}_{N-1}}$ is still a standard Stackelberg game. Similar to Section 3.2, we can get open-loop Stackelberg equilibrium $(\bar{u}_{N-1}(v_{N-1}) : \mathcal{V}[s_{N-2}, s_{N-1}] \times \mathbb{R}^n \rightarrow \mathcal{U}([s_{N-2}, s_{N-1}]), \bar{v}_{N-1} \in \mathcal{V}([s_{N-2}, s_{N-1}]))$ (see (32) and (33) for the representation by the operators or (39) for FBSDE representation). Now we will verify that the open-loop strategy $(\bar{u}_{N-1}(v_{N-1}), \bar{v}_{N-1})$ satisfies Definition 4 for $i = N - 1$. For the follower, for any $v_{N-1} \in \mathcal{V}([s_{N-2}, s_{N-1}])$ and (\bar{u}_N, \bar{v}_N) defined in (56),

$$\begin{aligned}
& J(s_{N-2}, \xi_{N-2}; \bar{u}_{N-1}(v_{N-1}) \oplus \bar{u}_N(\bar{v}_N), v_{N-1} \oplus \bar{v}_N) \\
&= \mathbb{E} \left\{ \int_{s_{N-2}}^{s_{N-1}} \left[\langle Q_1 x^{\bar{u}_{N-1}, v_{N-1}}, x^{\bar{u}_{N-1}, v_{N-1}} \rangle + \langle R_{J,1} \bar{u}_{N-1}(v_{N-1}), \bar{u}_{N-1}(v_{N-1}) \rangle + \langle R_{J,2} v_{N-1}, v_{N-1} \rangle \right] ds \right. \\
&\quad \left. + \int_{s_{N-1}}^{s_N} \left[\langle Q_1 x^{\bar{u}_{N-1}, v_{N-1}}, x^{\bar{u}_{N-1}, v_{N-1}} \rangle + \langle R_{J,1} \bar{u}_N(\bar{v}_N), \bar{u}_N(\bar{v}_N) \rangle + \langle R_{J,2} \bar{v}_N, \bar{v}_N \rangle \right] ds \right. \\
&\quad \left. + \langle G_1 x^{\bar{u}_{N-1}, v_{N-1}}(T), x^{\bar{u}_{N-1}, v_{N-1}}(T) \rangle \right\} \\
&= \mathbb{E} \left\{ \int_{s_{N-2}}^{s_{N-1}} \left[\langle Q_1 x^{\bar{u}_{N-1}(v_{N-1}), v_{N-1}}, x^{\bar{u}_{N-1}, v_{N-1}} \rangle + \langle R_{J,1} \bar{u}_{N-1}(v_{N-1}), \bar{u}_{N-1}(v_{N-1}) \rangle + \langle R_{J,2} v_{N-1}, v_{N-1} \rangle \right] ds \right. \\
&\quad \left. + \langle \widehat{P}_1^{(N)}(s_{N-1})x^{\bar{u}_{N-1}, v_{N-1}}(s_{N-1}), x^{\bar{u}_{N-1}, v_{N-1}}(s_{N-1}) \rangle \right\},
\end{aligned}$$

where

$$\begin{cases} dx^{\bar{u}_{N-1}, v_{N-1}} = \left[Ax^{\bar{u}_{N-1}, v_{N-1}} + B_1(\bar{u}_{N-1}(v_{N-1}) \oplus \bar{u}_N(\bar{v}_N)) + B_2(v_{N-1} \oplus \bar{v}_N) \right] ds \\ \quad + \left[Cx^{\bar{u}_{N-1}, v_{N-1}} + D_1(\bar{u}_{N-1}(v_{N-1}) \oplus \bar{u}_N(\bar{v}_N)) + D_2(v_{N-1} \oplus \bar{v}_N) \right] dW(s), \\ x^{\bar{u}_{N-1}, v_{N-1}}(s_{N-2}) = \xi_{N-2}. \end{cases}$$

Moreover, for any $u_{N-1} \in \mathcal{U}([s_{N-2}, s_{N-1}])$,

$$\begin{aligned}
& J(s_{N-2}, \xi_{N-2}; u_{N-1} \oplus \bar{u}_N(\bar{v}_N), v_{N-1} \oplus \bar{v}_N) \\
&= \mathbb{E} \left\{ \int_{s_{N-2}}^{s_{N-1}} \left[\langle Q_1 x^{u_{N-1}, v_{N-1}}, x^{u_{N-1}, v_{N-1}} \rangle + \langle R_{J,1} u_{N-1}, u_{N-1} \rangle + \langle R_{J,2} v_{N-1}, v_{N-1} \rangle \right] ds \right. \\
&\quad + \int_{s_{N-1}}^{s_N} \left[\langle Q_1 x^{u_{N-1}, v_{N-1}}, x^{u_{N-1}, v_{N-1}} \rangle + \langle R_{J,1} \bar{u}_N(\bar{v}_N), \bar{u}_N(\bar{v}_N) \rangle + \langle R_{J,2} \bar{v}_N, \bar{v}_N \rangle \right] ds \\
&\quad \left. + \langle G_1 x^{u_{N-1}, v_{N-1}}(T), x^{u_{N-1}, v_{N-1}}(T) \rangle \right\} \\
&= \mathbb{E} \left\{ \int_{s_{N-2}}^{s_{N-1}} \left[\langle Q_1 x^{u_{N-1}, v_{N-1}}, x^{u_{N-1}, v_{N-1}} \rangle + \langle R_{J,1} u_{N-1}, u_{N-1} \rangle + \langle R_{J,2} v_{N-1}, v_{N-1} \rangle \right] ds \right. \\
&\quad \left. + \langle \tilde{P}_1^{(N)}(s_{N-1}) x^{u_{N-1}, v_{N-1}}(s_{N-1}), x^{u_{N-1}, v_{N-1}}(s_{N-1}) \rangle \right\},
\end{aligned}$$

where

$$\begin{cases} dx^{u_{N-1}, v_{N-1}} = \left[Ax^{u_{N-1}, v_{N-1}} + B_1(u_{N-1} \oplus \bar{u}_N(\bar{v}_N)) + B_2(v_{N-1} \oplus \bar{v}_N) \right] ds \\ \quad + \left[Cx^{u_{N-1}, v_{N-1}} + D_1(u_{N-1} \oplus \bar{u}_N(\bar{v}_N)) + D_2(v_{N-1} \oplus \bar{v}_N) \right] dW(s), \\ x^{u_{N-1}, v_{N-1}}(s_{N-2}) = \xi_{N-2}. \end{cases}$$

By the definition of $\bar{u}_{N-1}(\cdot)$ (see (32) or (SG)), we have

$$J(s_{N-2}, \xi_{N-2}; \bar{u}_{N-1}(v_{N-1}) \oplus \bar{u}_N(\bar{v}_N), v_{N-1} \oplus \bar{v}_N) \leq J(s_{N-2}, \xi_{N-2}; u_{N-1} \oplus \bar{u}_N(\bar{v}_N), v_{N-1} \oplus \bar{v}_N).$$

For leader, we have

$$\begin{aligned}
& K(s_{N-2}, \xi_{N-2}; \bar{u}_{N-1}(v_{N-1}) \oplus \bar{u}_N(\bar{v}_N), v_{N-1} \oplus \bar{v}_N) \\
&= \mathbb{E} \left\{ \int_{s_{N-2}}^{s_{N-1}} \left[\langle Q_2 x^{\bar{u}_{N-1}, v_{N-1}}, x^{\bar{u}_{N-1}, v_{N-1}} \rangle + \langle R_{K,1} \bar{u}_{N-1}(v_{N-1}), \bar{u}_{N-1}(v_{N-1}) \rangle + \langle R_{K,2} v_{N-1}, v_{N-1} \rangle \right] ds \right. \\
&\quad + \int_{s_{N-1}}^{s_N} \left[\langle Q_2 x^{\bar{u}_{N-1}, v_{N-1}}, x^{\bar{u}_{N-1}, v_{N-1}} \rangle + \langle R_{K,1} \bar{u}_N(\bar{v}_N), \bar{u}_N(\bar{v}_N) \rangle + \langle R_{K,2} \bar{v}_N, \bar{v}_N \rangle \right] ds \\
&\quad \left. + \langle G_2 x^{\bar{u}_{N-1}, v_{N-1}}(T), x^{\bar{u}_{N-1}, v_{N-1}}(T) \rangle \right\} \\
&= \mathbb{E} \left\{ \int_{s_{N-2}}^{s_{N-1}} \left[\langle Q_2 x^{\bar{u}_{N-1}(v_{N-1}), v_{N-1}}, x^{\bar{u}_{N-1}(v_{N-1}), v_{N-1}} \rangle + \langle R_{K,1} \bar{u}_{N-1}(v_{N-1}), \bar{u}_{N-1}(v_{N-1}) \rangle + \langle R_{K,2} v_{N-1}, v_{N-1} \rangle \right] ds \right. \\
&\quad \left. + \langle \tilde{P}_1^{(N)}(s_{N-1}) x^{\bar{u}_{N-1}, v_{N-1}}(s_{N-1}), x^{\bar{u}_{N-1}, v_{N-1}}(s_{N-1}) \rangle \right\},
\end{aligned}$$

and

$$\begin{aligned}
& K(s_{N-2}, \xi_{N-2}; \bar{u}_{N-1}(\bar{v}_{N-1}) \oplus \bar{u}_N(\bar{v}_N), \bar{v}_{N-1} \oplus \bar{v}_N) \\
&= \mathbb{E} \left\{ \int_{s_{N-2}}^{s_{N-1}} \left[\langle Q_2 x^{\bar{u}_{N-1}, \bar{v}_{N-1}}, x^{\bar{u}_{N-1}, \bar{v}_{N-1}} \rangle + \langle R_{K,1} \bar{u}_{N-1}(\bar{v}_{N-1}), \bar{u}_{N-1}(\bar{v}_{N-1}) \rangle + \langle R_{K,2} \bar{v}_{N-1}, \bar{v}_{N-1} \rangle \right] ds \right. \\
&\quad + \int_{s_{N-1}}^{s_N} \left[\langle Q_2 x^{\bar{u}_{N-1}, \bar{v}_{N-1}}, x^{\bar{u}_{N-1}, \bar{v}_{N-1}} \rangle + \langle R_{K,1} \bar{u}_N(\bar{v}_N), \bar{u}_N(\bar{v}_N) \rangle + \langle R_{K,2} \bar{v}_N, \bar{v}_N \rangle \right] ds \\
&\quad \left. + \langle G_2 x^{\bar{u}_{N-1}, \bar{v}_{N-1}}(T), x^{\bar{u}_{N-1}, \bar{v}_{N-1}}(T) \rangle \right\} \\
&= \mathbb{E} \left\{ \int_{s_{N-2}}^{s_{N-1}} \left[\langle Q_2 x^{\bar{u}_{N-1}, \bar{v}_{N-1}}, x^{\bar{u}_{N-1}, \bar{v}_{N-1}} \rangle + \langle R_{K,1} \bar{u}_{N-1}(\bar{v}_{N-1}), \bar{u}_{N-1}(\bar{v}_{N-1}) \rangle + \langle R_{K,2} \bar{v}_{N-1}, \bar{v}_{N-1} \rangle \right] ds \right. \\
&\quad \left. + \langle \tilde{P}_1^{(N)}(s_{N-1}) x^{\bar{u}_{N-1}, \bar{v}_{N-1}}(s_{N-1}), x^{\bar{u}_{N-1}, \bar{v}_{N-1}}(s_{N-1}) \rangle \right\},
\end{aligned}$$

where

$$\begin{cases} dx^{\bar{u}_{N-1}, \bar{v}_{N-1}} = \left[Ax^{\bar{u}_{N-1}, \bar{v}_{N-1}} + B_1(\bar{u}_{N-1}(\bar{v}_{N-1}) \oplus \bar{u}_N(\bar{v}_N)) + B_2(\bar{v}_{N-1} \oplus \bar{v}_N) \right] ds \\ \quad + \left[Cx^{\bar{u}_{N-1}, \bar{v}_{N-1}} + D_1(\bar{u}_{N-1}(\bar{v}_{N-1}) \oplus \bar{u}_N(\bar{v}_N)) + D_2(\bar{v}_{N-1} \oplus \bar{v}_N) \right] dW(s), \\ x^{\bar{u}_{N-1}, \bar{v}_{N-1}}(s_{N-2}) = \xi_{N-2}. \end{cases}$$

Therefore, by the definition of \bar{v}_{N-1} (see (33) or (SG)),

$$K(s_{N-2}, \xi_{N-2}; \bar{u}_{N-1}(\bar{v}_{N-1}) \oplus \bar{u}_N(\bar{v}_N), \bar{v}_{N-1} \oplus \bar{v}_N) \leq K(s_{N-2}, \xi_{N-2}; \bar{u}_{N-1}(v_{N-1}) \oplus \bar{u}_N(\bar{v}_N), v_{N-1} \oplus \bar{v}_N).$$

Therefore, $(\bar{u}_{N-1}(\cdot), \bar{v}_{N-1})$ satisfies Definition 4 for $i = N - 1$.

Finally, we will obtain the state feedback representations of equilibrium strategy $(\bar{u}_{N-1}(v_{N-1}), \bar{v}_{N-1})$

$$\text{on } [s_{N-2}, s_{N-1}]. \text{ To this end, let } P^{(N-1)}, \hat{P}^{(N-1)} = \begin{pmatrix} \hat{P}_1^{(N-1)} & \hat{P}_2^{(N-1)} \\ \hat{P}_3^{(N-1)} & \hat{P}_4^{(N-1)} \end{pmatrix}, \tilde{P}^{(N-1)} = \begin{pmatrix} \tilde{P}_1^{(N-1)} & \tilde{P}_2^{(N-1)} \\ \tilde{P}_3^{(N-1)} & \tilde{P}_4^{(N-1)} \end{pmatrix}$$

be the solutions of

$$\begin{cases} \dot{P}^{(N-1)} + \mathcal{Q} + \mathcal{A}^\top P^{(N-1)} + P^{(N-1)} \mathcal{A} + P^{(N-1)} \mathcal{B} P^{(N-1)} + \mathcal{C}^\top (I - P^{(N-1)} \mathcal{H})^{-1} P^{(N-1)} \mathcal{C} \\ \quad + \mathcal{C}^\top (I - P^{(N-1)} \mathcal{H})^{-1} P^{(N-1)} \mathcal{F} P^{(N-1)} + P^{(N-1)} \mathcal{D} (I - P^{(N-1)} \mathcal{H})^{-1} P \mathcal{C} \\ \quad + P^{(N-1)} \mathcal{D} (I - P^{(N-1)} \mathcal{H})^{-1} P^{(N-1)} \mathcal{F} P^{(N-1)} = 0, \\ P^{(N-1)}(s_{N-1}) = \begin{pmatrix} \tilde{P}_1^{(N)}(s_{N-1}) & \hat{P}_1^{(N)}(s_{N-1}) \\ \tilde{P}_1^{(N)}(s_{N-1}) & 0 \end{pmatrix}, \\ \det[I - P^{(N-1)} \mathcal{H}] \neq 0, \end{cases}$$

$$\begin{cases} \dot{\hat{P}}^{(N-1)} + \hat{P}^{(N-1)} \mathbb{A}_{N-1} + \mathbb{A}_{N-1}^\top \hat{P}^{(N-1)} + \mathbb{B}_{N-1}^\top \hat{P}^{(N-1)} \mathbb{B}_{N-1} + \mathcal{Q}_{1, N-1} = 0, \\ \hat{P}^{(N-1)}(s_{N-1}) = \begin{pmatrix} \hat{P}_1^{(N)}(s_{N-1}) & 0 \\ 0 & 0 \end{pmatrix}, \end{cases}$$

and

$$\begin{cases} \dot{\tilde{P}}^{(N-1)} + \tilde{P}^{(N-1)} \mathbb{A}_{N-1} + \mathbb{A}_{N-1}^\top \tilde{P}^{(N-1)} + \mathbb{B}_{N-1}^\top \tilde{P}^{(N-1)} \mathbb{B}_{N-1} + \mathcal{Q}_{2, N-1} = 0, \\ \tilde{P}^{(N-1)}(s_{N-1}) = \begin{pmatrix} \tilde{P}_1^{(N)}(s_{N-1}) & 0 \\ 0 & 0 \end{pmatrix}, \end{cases}$$

where

$$\begin{aligned} \mathbb{A}_{N-1} &= \mathcal{A} + \mathcal{B} P^{(N-1)} + \mathcal{D} (I - P^{(N-1)} \mathcal{H})^{-1} \left[P^{(N-1)} \mathcal{C} + P^{(N-1)} \mathcal{F} P^{(N-1)} \right], \\ \mathbb{B}_{N-1} &= \mathcal{C} + \mathcal{F} P^{(N-1)} + \mathcal{H} (I - P^{(N-1)} \mathcal{H})^{-1} \left[P^{(N-1)} \mathcal{C} + P^{(N-1)} \mathcal{F} P^{(N-1)} \right], \\ \mathcal{Q}_{1, N-1} &= \begin{pmatrix} Q_1 & 0 \\ 0 & 0 \end{pmatrix} + A_{N-1}^\top R_1 A_{N-1}, \quad \mathcal{Q}_{2, N-1} = \begin{pmatrix} Q_2 & 0 \\ 0 & 0 \end{pmatrix} + A_{N-1}^\top R_2 A_{N-1}, \end{aligned}$$

and the other coefficients are defined in (52). Similar to Section 4.3.1, we have

$$\begin{pmatrix} \bar{u}_{N-1} \\ \bar{v}_{N-1} \end{pmatrix} = A_{N-1} X.$$

$$J(s_{N-2}, \xi_{N-2}; \bar{u}|_{s_{N-1}}, \bar{v}|_{s_{N-1}}) = \mathbb{E} \langle \hat{P}_1^{(N-1)}(s_{N-2}) \xi_{N-2}, \xi_{N-2} \rangle,$$

$$K(s_{N-2}, \xi_{N-2}; \bar{u}|_{\mathcal{S}_{N-1}}, \bar{v}|_{\mathcal{S}_{N-1}}) = \mathbb{E}(\tilde{P}_1^{(N-1)}(s_{N-2})\xi_{N-2}, \xi_{N-2}),$$

where

$$\Lambda_{N-1} = - \left[\begin{pmatrix} R_{J,1}^{-1} B_1^\top & 0 \\ 0 & R_{K,2}^{-1} B_2^\top \end{pmatrix} P^{(N-1)} + \begin{pmatrix} R_{J,1}^{-1} B_1^\top & 0 \\ 0 & R_{K,2}^{-1} B_2^\top \end{pmatrix} (I - P^{(N-1)}) \mathcal{H} \right]^{-1} (P^{(N-1)} \mathcal{C} + P^{(N-1)} \mathcal{F} P^{(N-1)}).$$

Continuing the above procedure, we can obtain the equilibrium strategies on each \mathcal{S}_i , $i = 1, \dots, N$.

4.3.3 Backward induction

The framework of backward procedure can be described by the following figure.

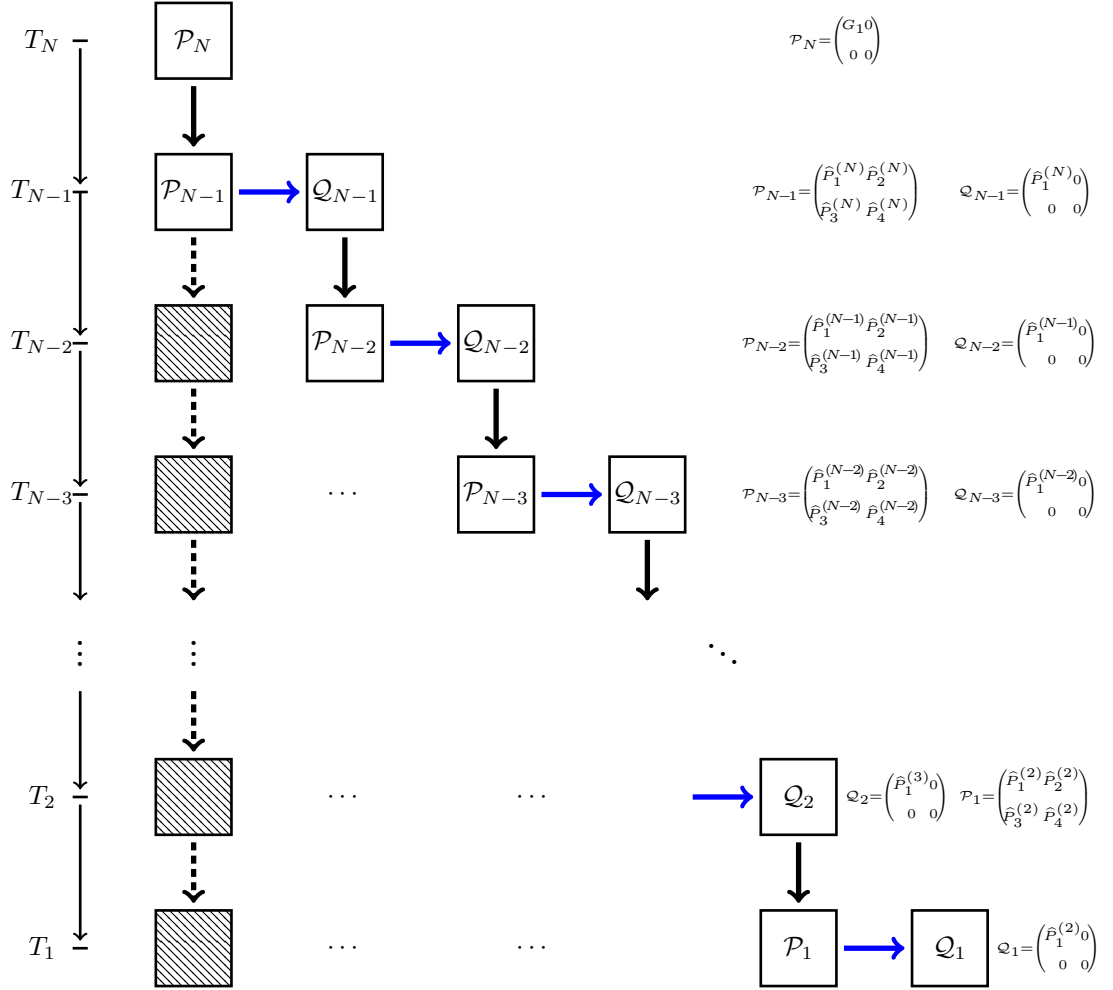

FIG. 5. Backward-procedure (\mathcal{A}_F): $\begin{cases} N > 1, \text{ solid arrow, local information, shifting,} \\ N = 1, \text{ dotted arrow, global information, no-shifting.} \end{cases}$

Stackelberg game with local information can be decomposed into a sequence of sub-games defined on each individual sub-intervals. These sub-games are solved *sequentially* in *backward-procedure* from top layer back to bottom one. For sub-game in each layer, a key component is the

control weight in cost (see $\mathcal{Q}_{N-1}, \dots, \mathcal{Q}_1$), that should be transmitted via a shifting operator from *Riccati-type optimality representation* in its next upper layer (e.g., the blue arrows).

Remark 2 For the concise of pictures, we only give the procedure for \mathcal{A}_F and omit the time variables in above backward and forward procedures. Note that at s_{N-1} , the weight matrix should be

$$\begin{pmatrix} \widehat{P}_1^{(N)}(s_{N-1}) & \widehat{P}_2^{(N)}(s_{N-1}) \\ \widehat{P}_3^{(N)}(s_{N-1}) & \widehat{P}_4^{(N)}(s_{N-1}) \end{pmatrix}, \begin{pmatrix} \widehat{P}_1^{(N)}(s_{N-1}) & 0 \\ 0 & 0 \end{pmatrix}.$$

The weight matrices at time s_{N-2}, \dots, s_1 are similar.

Remark 3 On \mathcal{S}_N , we have constructed the closed-loop representation of equilibrium strategies and the representation (e.g., (56)) on \mathcal{S}_N depends on the “state” $X(s) = \begin{pmatrix} x(s) \\ \varphi_N(s) \end{pmatrix}$, $s_{N-1} \leq s \leq s_N$. Note that $x(s)$ is the real state which can be observed. However, $\varphi_N(s)$ is the adjoint equation which is a virtual state which cannot be observed. Therefore, (56) is not actually a closed-loop representation. In other words, the backward procedure is not enough to solve Stackelberg game with local information. In the following, we will apply the forward procedure to fully solve Stackelberg game with local information.

4.4 Forward procedure

In Section 4.3, we use the backward procedure to find equilibrium strategies on \mathcal{S}_i , $i = N, \dots, 1$. Note that the strategies on \mathcal{S}_i depend on $x(s_{i-1})$ which is undetermined when considering the Stackelberg game on \mathcal{S}_i , $i = 2, \dots, n$, and is known only for $i = 1$. Therefore, based on the computations in Section 4.3, in this section we will finally solve the Stackelberg game forwardly.

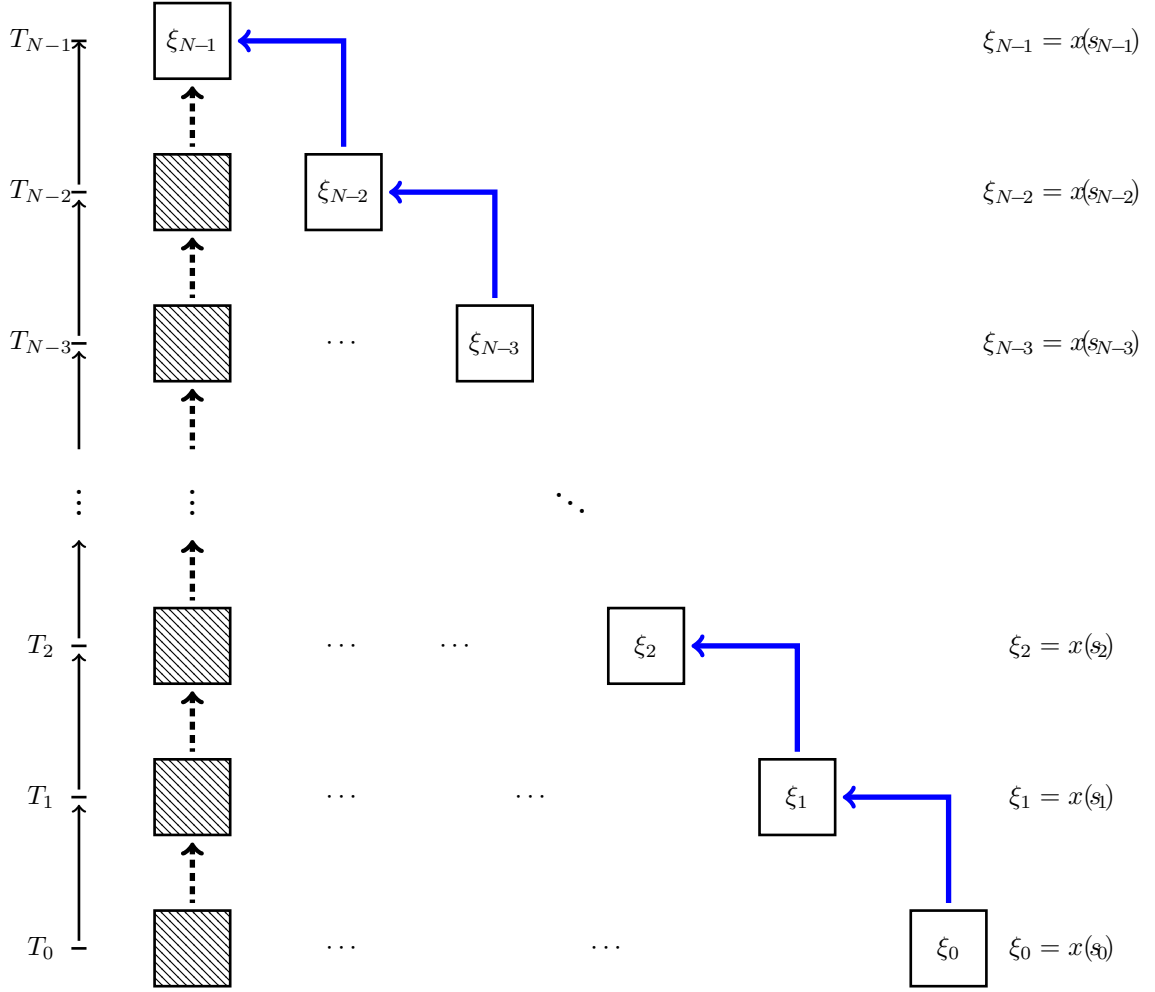

FIG. 6. Forward-procedure: $\begin{cases} N > 1, \text{ solid arrow, local information, shifting,} \\ N = 1, \text{ dotted arrow, global information, no-shifting.} \end{cases}$

Unlike standard control, for Stackelberg game, its close-loop representation must be constructed upon an augmented forward state pair including an auxiliary φ_i (e.g., (51)). Such auxiliary component is a “virtual” state and differs essentially from the “real physical” one x_i (e.g., (51)). Especially, it cannot be simultaneously observed/measured in real world. Instead, it must be computed *off-line* with x_i using its *joint evolution* dynamics that further depends on the *initial state condition* (i.e., (51)) in each sub-interval. All such initial conditions are undetermined during back-procedure. After backward-procedure, all control weights in each sub-game have been set, and we may proceed a forward-procedure (from bottom to top layer) to determine such initial conditions (actually, they are *terminal* conditions in previous layer) and noting the most initial one at $t = 0$ is already given a priori.

Let $P^{(N)}, \widehat{P}^{(N)} = \begin{pmatrix} \widehat{P}_1^{(N)} & \widehat{P}_2^{(N)} \\ \widehat{P}_3^{(N)} & \widehat{P}_4^{(N)} \end{pmatrix}, \widetilde{P}^{(N)} = \begin{pmatrix} \widetilde{P}_1^{(N)} & \widetilde{P}_2^{(N)} \\ \widetilde{P}_3^{(N)} & \widetilde{P}_4^{(N)} \end{pmatrix}$ be the solutions of Riccati equations (54), (58) and (59) on $[s_{N-1}, s_N]$ respectively. For $i = 1, 2, \dots, N - 1$, on $[s_{i-1}, s_i]$, let $P^{(i)}$,

$\widehat{P}^{(i)} = \begin{pmatrix} \widehat{P}_1^{(i)} & \widehat{P}_2^{(i)} \\ \widehat{P}_3^{(i)} & \widehat{P}_4^{(i)} \end{pmatrix}$, $\widetilde{P}^{(i)} = \begin{pmatrix} \widetilde{P}_1^{(i)} & \widetilde{P}_2^{(i)} \\ \widetilde{P}_3^{(i)} & \widetilde{P}_4^{(i)} \end{pmatrix}$ be the solutions of

$$\begin{cases} \dot{P}^{(i)} + Q + A^\top P^{(i)} + P^{(i)}A + P^{(i)}BP^{(i)} + C^\top(I - P^{(i)}\mathcal{H})^{-1}P^{(i)}C + C^\top(I - P^{(i)}\mathcal{H})^{-1}P^{(i)}\mathcal{F}P^{(i)} \\ + P^{(i)}\mathcal{D}(I - P^{(i)}\mathcal{H})^{-1}PC + P^{(i)}\mathcal{D}(I - P^{(i)}\mathcal{H})^{-1}P^{(i)}\mathcal{F}P^{(i)} = 0, \\ P^{(i)}(s_i) = \mathcal{G}_i, \\ \det[I - P^{(i)}\mathcal{H}] \neq 0, \end{cases}$$

$$\dot{\widehat{P}}^{(i)} + \widehat{P}^{(i)}\mathbb{A}_i + \mathbb{A}_i^\top \widehat{P}^{(i)} + \mathbb{B}_i^\top \widehat{P}^{(i)}\mathbb{B}_i + \mathcal{Q}_{1,i} = 0, \quad \widehat{P}^{(i)}(s_i) = \mathcal{G}_{1,i},$$

$$\dot{\widetilde{P}}^{(i)} + \widetilde{P}^{(i)}\mathbb{A}_i + \mathbb{A}_i^\top \widetilde{P}^{(i)} + \mathbb{B}_i^\top \widetilde{P}^{(i)}\mathbb{B}_i + \mathcal{Q}_{2,i} = 0, \quad \widetilde{P}^{(i)}(s_i) = \mathcal{G}_{2,i},$$

where

$$\mathbb{A}_i = A + BP^{(i)} + \mathcal{D}(I - P^{(i)}\mathcal{H})^{-1}[P^{(i)}C + P^{(i)}\mathcal{F}P^{(i)}],$$

$$\mathbb{B}_i = C + \mathcal{F}P^{(i)} + \mathcal{H}(I - P^{(i)}\mathcal{H})^{-1}[P^{(i)}C + P^{(i)}\mathcal{F}P^{(i)}],$$

$$\mathbb{A}_i = -\left[\begin{pmatrix} R_{J,1}^{-1}B_1^\top & 0 \\ 0 & R_{K,2}^{-1}B_2^\top \end{pmatrix} P^{(i)} + \begin{pmatrix} R_{J,1}^{-1}B_1^\top & 0 \\ 0 & R_{K,2}^{-1}B_2^\top \end{pmatrix} (I - P^{(i)}\mathcal{H})^{-1}(P^{(i)}C + P^{(i)}\mathcal{F}P^{(i)}) \right],$$

$$\mathcal{G}_i = \begin{pmatrix} \widehat{P}_1^{(i+1)}(s_i) & \widehat{P}_1^{(i+1)}(s_i) \\ \widehat{P}_1^{(i+1)}(s_i) & 0 \end{pmatrix}, \quad \mathcal{Q}_{1,i} = \begin{pmatrix} Q_1 & 0 \\ 0 & 0 \end{pmatrix} + \mathbb{A}_i^\top R_1 \mathbb{A}_i, \quad \mathcal{G}_{1,i} = \begin{pmatrix} \widehat{P}_1^{(i+1)}(s_i) & 0 \\ 0 & 0 \end{pmatrix},$$

$$\mathcal{Q}_{2,i} = \begin{pmatrix} Q_2 & 0 \\ 0 & 0 \end{pmatrix} + \mathbb{A}_i^\top R_2 \mathbb{A}_i, \quad \mathcal{G}_{2,i} = \begin{pmatrix} \widehat{P}_1^{(i+1)}(s_i) & 0 \\ 0 & 0 \end{pmatrix}.$$

4.4.1 Stackelberg game on \mathcal{S}_i , $i = 1, \dots, N$

Let $\bar{x}_0(s_0) = \xi$. On \mathcal{S}_i , the costs of \mathcal{A}_F and \mathcal{A}_L are

$$\begin{cases} J_i(s_{i-1}, \bar{x}(s_{i-1}); u|_{\mathcal{S}_i}, v|_{\mathcal{S}_i}) \\ = \mathbb{E} \left\{ \int_{s_{i-1}}^{s_i} \left[\langle Q_1(s)x(s), x(s) \rangle + \langle R_{J,1}(s)u(s), u(s) \rangle + \langle R_{J,2}(s)v(s), v(s) \rangle \right] ds + \langle \widehat{P}_1^{(i+1)}(s_i)x(s_i), x(s_i) \rangle \right\}, \\ K_i(s_{i-1}, \bar{x}(s_{i-1}); u|_{\mathcal{S}_i}, v|_{\mathcal{S}_i}) \\ = \mathbb{E} \left\{ \int_{s_{i-1}}^{s_i} \left[\langle Q_2(s)x(s), x(s) \rangle + \langle R_{K,1}(s)u(s), u(s) \rangle + \langle R_{K,2}(s)v(s), v(s) \rangle \right] ds + \langle \widehat{P}_1^{(i+1)}(s_i)x(s_i), x(s_i) \rangle \right\}, \end{cases}$$

where

$$\begin{cases} dx(s) = [A(s)x(s) + B_1(s)u(s) + B_2(s)v(s)]ds + [C(s)x(s) + B_1(s)u(s) + B_2(s)v(s)]dW(s), \quad s_{i-1} \leq s \leq s_i, \\ x(s_{i-1}) = \bar{x}_{i-1}(s_{i-1}). \end{cases}$$

Similar to Section 4.3, we have

$$\begin{pmatrix} \bar{u}|_{\mathcal{S}_i} \\ \bar{v}|_{\mathcal{S}_i} \end{pmatrix} = -\left[\begin{pmatrix} R_{J,1}^{-1}B_1^\top & 0 \\ 0 & R_{K,2}^{-1}B_2^\top \end{pmatrix} P^{(i)} + \begin{pmatrix} R_{J,1}^{-1}B_1^\top & 0 \\ 0 & R_{K,2}^{-1}B_2^\top \end{pmatrix} (I - P^{(i)}\widehat{\mathcal{H}})^{-1}(P^{(i)}\widehat{C} + P^{(i)}\widehat{\mathcal{F}}P^{(i)}) \right] X, \quad (62)$$

$$\begin{aligned} J(s_{i-1}, \bar{x}(s_{i-1}); \bar{u}|_{\mathcal{S}_i}(\cdot), \bar{v}|_{\mathcal{S}_i}(\cdot)) &= \mathbb{E}\langle \widehat{P}_1^{(i)}(s_{i-1})\bar{x}(s_{i-1}), \bar{x}(s_{i-1}) \rangle, \\ K(s_{i-1}, \bar{x}(s_{i-1}); \bar{u}|_{\mathcal{S}_i}(\cdot), \bar{v}|_{\mathcal{S}_i}(\cdot)) &= \mathbb{E}\langle \widetilde{P}_1^{(i)}(s_{i-1})\bar{x}(s_{i-1}), \bar{x}(s_{i-1}) \rangle, \end{aligned}$$

where $\bar{X}_i = (\bar{x}_i \ \bar{\varphi}_i)^\top$ satisfies

$$dX = \mathbb{A}_i X dt + \mathbb{B}_i X dW, \quad X(s_{i-1}) = (\bar{x}(s_{i-1}), 0),$$

with

$$\mathbb{A}_i = \mathcal{A} + \mathcal{B}P^{(i)} + \mathcal{D}(I - P^{(i)}\mathcal{H})^{-1} \left[P^{(i)}\mathcal{C} + P^{(i)}\mathcal{F}P^{(i)} \right], \quad \mathbb{B}_i = \mathcal{C} + \mathcal{F}P^{(i)} + \mathcal{H}(I - P^{(i)}\mathcal{H})^{-1} \left[P^{(i)}\mathcal{C} + P^{(i)}\mathcal{F}P^{(i)} \right].$$

Therefore, the equilibrium strategies of \mathcal{A}_F and \mathcal{A}_L on $[0, T]$ are

$$\bar{u}(s) = \bar{u}|_{\mathcal{S}_i}(s), \quad \bar{v}(s) = \bar{v}|_{\mathcal{S}_i}(s), \quad s \in \mathcal{S}_i, \quad i = 1, \dots, N. \quad (63)$$

Note that the equilibrium strategies (63) (or (62)) involves the equations $P^{(i)}$, $\widehat{P}^{(i)}$ and $\widetilde{P}^{(i)}$ for $i = 1, \dots, N$. The general solvability of such Riccati equations are quite challenging and remains widely open and we will present the solvability for some special but nontrivial case.

Remark 4 For (SG), in order to apply best response and iterative optimization, the leader must know the follower's cost functional while the follower does not need to know that of the leader, that is, the information of the leader and follower are not symmetric. However, for (SL), by (63) (or (62)) with $P^{(i)}$, $\widehat{P}^{(i)}$ and $\widetilde{P}^{(i)}$, the follower must also know the cost functional of the leader, otherwise the framework of (SL) is infeasible. Moreover, from Section 3.2.4 we know that (SG) is time-inconsistent. For (SL), the equilibrium strategy is still time-inconsistent. However, the equilibrium strategy is time-consistent at the time spot s_i , $i = 1, \dots, N - 1$. That is, the leader would not benefit by choosing another strategy than the equilibrium strategy he/she chose at time spot s_i , $i = 1, \dots, N - 1$.

4.5 Special case: $D_1 = D_2 = 0$

For the one-dimensional case with $D_1 = D_2 = 0$, (53) takes the following form:

$$\begin{cases} dX = [\mathcal{A}X + \mathcal{B}Y] ds + \mathcal{C}X dW, \\ dY = -[\mathcal{Q}X + \mathcal{A}^\top Y + \mathcal{C}^\top Z] ds + Z dW, \\ X(s_{N-1}) = \zeta_{N-1}, \quad Y(s_N) = \mathcal{G}X(s_N), \end{cases}$$

Therefore, similar to Section 4.4, for $i = 1, \dots, N$ and on $[s_{i-1}, s_i]$, introduce the following Riccati equations

$$\dot{P}^{(i)} + \mathcal{Q} + \mathcal{A}^\top P^{(i)} + P^{(i)}\mathcal{A} + P^{(i)}\mathcal{B}P^{(i)} + \mathcal{C}^\top P^{(i)}\mathcal{C} = 0, \quad P^{(i)}(s_i) = \mathcal{G}_i, \quad (64)$$

$$\dot{\widehat{P}}^{(i)} + \widehat{P}^{(i)}(\mathcal{A} + \mathcal{B}P^{(i)}) + (\mathcal{A} + \mathcal{B}P^{(i)})^\top \widehat{P}^{(i)} + \mathcal{C}^\top \widehat{P}^{(i)}\mathcal{C} + \mathcal{Q}_{1,i} = 0, \quad \widehat{P}^{(i)}(s_i) = \mathcal{G}_{1,i}, \quad (65)$$

$$\dot{\widetilde{P}}^{(i)} + \widetilde{P}^{(i)}(\mathcal{A} + \mathcal{B}P^{(i)}) + (\mathcal{A} + \mathcal{B}P^{(i)})^\top \widetilde{P}^{(i)} + \mathcal{C}^\top \widetilde{P}^{(i)}\mathcal{C} + \mathcal{Q}_{2,i} = 0, \quad \widetilde{P}^{(i)}(s_i) = \mathcal{G}_{2,i}, \quad (66)$$

where

$$\mathcal{G}_n = \mathcal{G}, \quad \mathcal{G}_{1,N} = \begin{pmatrix} G_1 & 0 \\ 0 & 0 \end{pmatrix}, \quad \mathcal{G}_{2,N} = \begin{pmatrix} G_2 & 0 \\ 0 & 0 \end{pmatrix},$$

$$\begin{aligned} \Lambda_i &= - \left[\begin{pmatrix} R_{J,1}^{-1} B_1^\top & 0 \\ 0 & R_{K,2}^{-1} B_2^\top \end{pmatrix} P^{(i)} + \begin{pmatrix} R_{J,1}^{-1} B_1^\top & 0 \\ 0 & R_{K,2}^{-1} B_2^\top \end{pmatrix} P^{(i)} \mathcal{C}, \right. \\ \mathcal{Q}_{1,i} &= \begin{pmatrix} Q_1 & 0 \\ 0 & 0 \end{pmatrix} + \Lambda_i^\top R_1 \Lambda_i, \quad \mathcal{Q}_{2,i} = \begin{pmatrix} Q_2 & 0 \\ 0 & 0 \end{pmatrix} + \Lambda_i^\top R_2 \Lambda_i, \quad i = 1, \dots, N; \\ \mathcal{G}_i(s_i) &= \begin{pmatrix} \tilde{P}_1^{(i+1)}(s_i) & \hat{P}_1^{(i+1)}(s_i) \\ \hat{P}_1^{(i+1)}(s_i) & 0 \end{pmatrix}, \quad \mathcal{G}_{1,i} = \begin{pmatrix} \hat{P}_1^{(i+1)}(s_i) & 0 \\ 0 & 0 \end{pmatrix}, \quad \mathcal{G}_{2,i} = \begin{pmatrix} \tilde{P}_1^{(i+1)}(s_i) & 0 \\ 0 & 0 \end{pmatrix}, \quad i = 1, \dots, N-1. \end{aligned}$$

Therefore, the equilibrium strategies of \mathcal{A}_F and \mathcal{A}_L on $[0, T]$ are

$$\bar{u}(s) = \bar{u}|_{\mathcal{S}_i}(s), \quad \bar{v}(s) = \bar{v}|_{\mathcal{S}_i}(s), \quad s \in \mathcal{S}_i, \quad i = 1, \dots, N.$$

Proposition 15 *Under (H1) and (H2), suppose*

$$\frac{Q_1}{Q_2} = \frac{G_1}{G_2} = \frac{R_{J,1}}{R_{K,1}} = \frac{R_{J,2}}{R_{K,2}},$$

then (64), (65) and (66) admit a unique solution.

Proof First consider the case $i = N$. Let $\Phi = \begin{pmatrix} 1 & 0 \\ 2\alpha & 1 \end{pmatrix}$, $\Psi = \begin{pmatrix} 1 & 0 \\ 0 & -1 \end{pmatrix}$, and define $\hat{X} = \Psi X$, $Y = \Phi \hat{Y}$ and $Z = \Phi \hat{Z}$ we have

$$\begin{cases} d\hat{X} = [\mathcal{A}\hat{X} - \hat{\mathcal{B}}\hat{Y}]ds + \mathcal{C}\hat{X}dW, \\ d\hat{Y} = -[\hat{\mathcal{Q}}\hat{X} + \mathcal{A}^\top \hat{Y} + \mathcal{C}^\top \hat{Z}]ds + \hat{Z}dW, \\ \hat{X}(0) = 0, \quad \hat{Y}(T) = \hat{\mathcal{G}}\hat{X}(T), \end{cases}$$

where

$$\begin{aligned} \hat{\mathcal{B}} &= \begin{pmatrix} B_2 R_{K,2}^{-1} B_2^\top + 2\alpha B_1 R_{J,1}^{-1} B_1^\top & B_1 R_{J,1}^{-1} B_1^\top \\ -B_1 R_{J,1}^{-1} B_1^\top + 2\alpha B_1 R_{J,1}^{-1} R_{K,1} R_{J,1}^{-1} B_1^\top & B_1 R_{J,1}^{-1} R_{K,1} R_{J,1}^{-1} B_1^\top \end{pmatrix}, \\ \hat{\mathcal{Q}} &= \begin{pmatrix} Q_2 & -Q_1 \\ -2\alpha Q_2 + Q_1 & 2\alpha Q_1 \end{pmatrix}, \quad \hat{\mathcal{G}} = \begin{pmatrix} G_2 & -G_1 \\ -2\alpha G_2 + G_1 & 2\alpha G_1 \end{pmatrix}. \end{aligned}$$

Suppose

$$\alpha = \frac{Q_1}{Q_2} = \frac{G_1}{G_2} = \frac{R_{J,1}}{R_{K,1}} = \frac{R_{J,2}}{R_{K,2}},$$

we have

$$\hat{\mathcal{B}} = \begin{pmatrix} B_2 R_{K,2}^{-1} B_2^\top + 2\alpha B_1 R_{J,1}^{-1} B_1^\top & B_1 R_{J,1}^{-1} B_1^\top \\ B_1 R_{J,1}^{-1} B_1^\top & B_1 R_{J,1}^{-1} B_1^\top / \alpha \end{pmatrix}, \quad \hat{\mathcal{Q}} = \begin{pmatrix} Q_2 & -Q_1 \\ -Q_1 & 2\alpha Q_1 \end{pmatrix}, \quad \hat{\mathcal{G}} = \begin{pmatrix} G_2 & -G_1 \\ -G_1 & 2\alpha G_1 \end{pmatrix},$$

are symmetric positive-definite matrices. Therefore,

$$\dot{\hat{P}}^{(N)} + \hat{\mathcal{Q}} + \mathcal{A}^\top \hat{P}^{(N)} + \hat{P}^{(N)} \mathcal{A} + \hat{P}^{(N)} \hat{\mathcal{B}} \hat{P}^{(N)} + \mathcal{C}^\top \hat{P}^{(N)} \mathcal{C} = 0, \quad \hat{P}^{(N)}(s_N) = \hat{\mathcal{G}},$$

admits a unique solution. Therefore, by the relation $Y = P^{(N)} X$, $\hat{Y} = \hat{P}^{(N)} \hat{X}$, $\hat{X} = \Psi X$, $Y = \Phi \hat{Y}$, we have $P^{(N)} = \Phi \hat{P}^{(N)} \Psi$. Therefore, for $i = N$, (64) admits a unique solution. Consequently, for $i = N$, (65) and (66) admit unique solutions. Moreover, by

$$\mathcal{Q}_{1,N} = \alpha \mathcal{Q}_{2,N}, \quad \mathcal{G}_{1,N} = \alpha \mathcal{G}_{2,N},$$

we have

$$\widehat{P}^{(N)}(\cdot) = \alpha \widetilde{P}^{(N)}(\cdot).$$

Hence, $\widehat{P}_1^{(N)}(s_{N-1}) = \alpha \widetilde{P}_1^{(N)}(s_{N-1})$.

Note that

$$\alpha = \frac{Q_1}{Q_2} = \frac{\widehat{P}_1^{(N)}(s_{N-1})}{\widetilde{P}_1^{(N)}(s_{N-1})} = \frac{R_{J,1}}{R_{K,1}} = \frac{R_{J,2}}{R_{K,2}},$$

repeating the above process for $i = N - 1$, we get that (64),(65) and (66) admit unique solutions and

$$\widehat{P}^{(N-1)}(\cdot) = \alpha \widetilde{P}^{(N-1)}(\cdot).$$

Therefore, continuing the process for $i = N - 2, i = 1$, we get that (65) and (66) admit unique solutions.

5 Relation among (NG₀), (SG₀) and (SL₀)

5.1 Relation between (NG₀) and (SG₀)

In this subsection, we will show that for (NG₀), the Nash equilibrium can also be solved by solving as Stackelberg game (SG₀), i.e., assuming that player 1 is the follower and player 2 is the leader. More specifically, we will compare (NG₀) with (SG₀) by abstract representation, Hamiltonian system and Riccati equation.

5.1.1 Abstract representation

Proposition 16 *Let (H1) and (H2) hold. Suppose $M_2 \gg 0$ and $M_1 \ll 0$, then the Stackelberg equilibrium $(\bar{u}(\bar{v}(\cdot))(\cdot), \bar{v}(\cdot))$ of (SG₀) is a saddle point of (NG₀).*

Proof By (31), we have

$$\bar{u}(v(\cdot))(\cdot) = M_1^{-1}(-M_{12}(v) - M_{13}(\xi)).$$

Therefore,

$$\begin{aligned} & K(v(\cdot), \bar{u}(v(\cdot))(\cdot); \xi) \\ &= \frac{1}{2} \left[\langle N_1(v), v \rangle + \langle N_2(M_1^{-1}(-M_{12}(v) - M_{13}(\xi))), M_1^{-1}(-M_{12}(v) - M_{13}(\xi)) \rangle + \langle N_3(\xi), \xi \rangle \right. \\ & \quad \left. + 2\langle N_{12}(M_1^{-1}(-M_{12}(v) - M_{13}(\xi))), v \rangle + 2\langle N_{13}(\xi), M_1^{-1}(-M_{12}(v) - M_{13}(\xi)) \rangle + 2\langle N_{23}(\xi), v \rangle \right] \\ &= -\frac{1}{2} \left[\langle M_2(v) - M_{12}^*(M_1^{-1})M_{12}(v), v \rangle + 2\langle -M_{12}^*(M_1^{-1})M_{13}(\xi) + M_{23}(\xi), v \rangle \right. \\ & \quad \left. + \langle M_3(\xi) - M_{13}^*(M_1^{-1})M_{13}(\xi), \xi \rangle \right]. \end{aligned}$$

Then \bar{v} satisfies

$$M_2(\bar{v}) - M_{12}^*M_1^{-1}M_{12}(\bar{v}) + M_{23}(\xi) - M_{12}^*M_1^{-1}M_{13}(\xi) = 0,$$

i.e.,

$$M_2(\bar{v}) + M_{12}^*(-M_1^{-1}M_{12}(\bar{v}) - M_1^{-1}M_{13}(\xi)) + M_{23}(\xi) = 0.$$

By Proposition 3, we get that (\bar{u}, \bar{v}) is a Nash equilibrium for (NG₀).

Similarly, (NG₀) can also be solved by assuming that player 2 is the follower and player 1 is the leader.

5.1.2 Hamiltonian system

For (SG_0) , i.e., $J(t, \xi; u(\cdot), v(\cdot)) + K(t, \xi; u(\cdot), v(\cdot)) = 0$, (35) becomes

$$\begin{cases} d\bar{x} = \left[A\bar{x} - \widehat{B}_1\bar{y} - \widehat{F}_1\bar{z} - \widehat{B}_2\bar{\phi} - \widehat{D}_2\bar{\theta} \right] ds + \left[C\bar{x} - \widehat{D}_1\bar{y} - \widehat{F}_2\bar{z} - \widehat{D}_2^\top\bar{\phi} - \widehat{D}_3\bar{\theta} \right] dW(s), \\ d\bar{y} = \left[-A^\top\bar{y} - C^\top\bar{z} - Q_1\bar{x} \right] ds + \bar{z}dW(s), \\ d\bar{\phi} = \left[-A^\top\bar{\phi} - C^\top\bar{\theta} - Q_1\bar{\varphi} + Q_1\bar{x} \right] ds + \bar{\theta}dW(s), \\ d\bar{\varphi} = \left[A\bar{\varphi} - \widehat{B}_1(\bar{y} + \bar{\phi}) - \widehat{F}_1(\bar{z} + \bar{\theta}) \right] ds + \left[C\bar{\varphi} - \widehat{D}_1(\bar{y} + \bar{\phi}) - \widehat{F}_2(\bar{z} + \bar{\theta}) \right] dW(s), \\ \bar{x}(t) = \xi, \quad \bar{y}(T) = G_1\bar{x}(T), \quad \bar{\phi}(T) = -G_1\bar{x}(T) + G_1\bar{\varphi}(T), \quad \bar{\varphi}(t) = 0. \end{cases}$$

Moreover, we have

$$\begin{cases} d(\bar{y} + \bar{\phi}) = \left[-A^\top(\bar{y} + \bar{\phi}) - C^\top(\bar{z} + \bar{\theta}) - Q_1\bar{\varphi} \right] ds + (\bar{z} + \bar{\theta})dW(s), \\ \bar{y}(T) + \bar{\phi}(T) = G_1\bar{\varphi}(T). \end{cases}$$

Therefore,

$$\bar{\varphi}(s) = \bar{y}(s) + \bar{\phi}(s) = \bar{z}(s) + \bar{\theta}(s) = 0, \quad s \in [t, T].$$

Hence the Hamilton system reduces to

$$\begin{cases} d\bar{x} = \left[A\bar{x} - (\widehat{B}_1 - \widehat{B}_2)\bar{y} - (\widehat{F}_1 - \widehat{D}_2)\bar{z} \right] ds + \left[C\bar{x} - (\widehat{D}_1 - \widehat{D}_2^\top)\bar{y} - (\widehat{F}_2 - \widehat{D}_3)\bar{z} \right] dW(s), \\ d\bar{y} = \left[-A^\top\bar{y} - C^\top\bar{z} - Q_1\bar{x} \right] ds + \bar{z}dW(s), \\ \bar{x}(t) = \xi, \quad \bar{y}(T) = G_1\bar{x}(T), \end{cases}$$

Therefore, we have the following result.

Proposition 17 *Under (H1)-(H2), assume $M_1 > 0$ and $M_2 \geq 0$. Moreover, suppose $R_{J,1}(\cdot), R_{K,2}(\cdot)$ are invertible and $R_{J,1}(\cdot) \in L^\infty(t, T; \mathbb{S}^{m_1}), R_{K,2}(\cdot) \in L^\infty(t, T; \mathbb{S}^{m_2})$, then the Stackelberg equilibrium*

$$\bar{u} = -R_{J,1}^{-1}(B_1^\top\bar{y} + D_1^\top\bar{z}), \quad \bar{v} = -R_{J,2}^{-1}(B_2^\top\bar{y} + D_2^\top\bar{z}),$$

of Problem (SG_0) is a saddle point of (NG_0) .

5.1.3 Riccati equation

For (SG_0) , Hamiltonian system (40) is the same as that of (NG_0) , therefore, the Riccati equation for (SG_0) is the same as that of (NG_0) , i.e., (22).

Proposition 18 *Suppose that Riccati equation (22) and (26) admit solutions, then the saddle point of (NG_0) and Stackelberg equilibrium of (SG_0) have the following representation:*

$$\begin{cases} \bar{u}(s) = -R_{J,1}^{-1}(B_1^\top\Pi_1 + D_1^\top(I + \Pi_1(\widehat{F}_2 - \widehat{D}_3))^{-1}(\Pi_1C - \Pi_1(\widehat{D}_1 - \widehat{D}_2^\top)\Pi_1))\bar{x}, \\ \bar{v}(s) = -R_{J,2}^{-1}(B_2^\top\Pi_1 + D_2^\top(I + \Pi_1(\widehat{F}_2 - \widehat{D}_3))^{-1}(\Pi_1C - \Pi_1(\widehat{D}_1 - \widehat{D}_2^\top)\Pi_1))\bar{x}. \end{cases}$$

Furthermore, the optimal functionals are

$$J(t, \xi; \bar{u}, \bar{v}) = \mathbb{E}\langle \widehat{p}_2^{(1)}(t)\xi, \xi \rangle = -K(t, \xi; \bar{u}, \bar{v}),$$

where \widehat{p}_2 is the solution of (26).

5.2 Relation between (SG₀) and (SL₀)

For (SL₀), on \mathcal{S}_N , by Proposition 13, we have the Stackelberg equilibrium has the following representation:

$$\begin{cases} \bar{u}|_{\mathcal{S}_N} = -R_{J,1}^{-1}(B_1^\top \Pi_1^{(N)} + D_1^\top (I + \Pi_1^{(N)}(\hat{F}_2 - \hat{D}_3))^{-1}(\Pi_1^{(N)}C - \Pi_1^{(N)}(\hat{D}_1 - \hat{D}_2^\top)\Pi_1^{(N)}))\bar{x}^{(N)}, \\ \bar{v}|_{\mathcal{S}_N} = -R_{J,2}^{-1}(B_2^\top \Pi_1^{(N)} + D_2^\top (I + \Pi_1^{(N)}(\hat{F}_2 - \hat{D}_3))^{-1}(\Pi_1^{(N)}C - \Pi_1^{(N)}(\hat{D}_1 - \hat{D}_2^\top)\Pi_1^{(N)}))\bar{x}^{(N)}. \end{cases}$$

where

$$\begin{cases} \dot{\Pi}_1^{(N)} + \Pi_1^{(N)}A + A^\top \Pi_1^{(N)} - \Pi_1^{(N)}(\hat{B}_1 - \hat{B}_2)\Pi_1^{(N)} \\ - \Pi_1^{(N)}(\hat{D}_1^\top - \hat{D}_2)(I + \Pi_1^{(N)}(\hat{F}_2 - \hat{D}_3))^{-1}(\Pi_1^{(N)}C - \Pi_1^{(N)}(\hat{D}_1 - \hat{D}_2^\top)\Pi_1^{(N)}) \\ + C^\top (I + \Pi_1^{(N)}(\hat{F}_2 - \hat{D}_3))^{-1}(\Pi_1^{(N)}C - \Pi_1^{(N)}(\hat{D}_1 - \hat{D}_2^\top)\Pi_1^{(N)}) + Q_1 = 0, \\ \Pi_1^{(N)}(T) = G_1. \end{cases}$$

and

$$\begin{cases} d\bar{x}^{(N)} = \left[A\bar{x}^{(N)} - \hat{B}_1\bar{y}^{(N)} - \hat{D}_1^\top \bar{z}^{(N)} + \hat{B}_2\bar{y}^{(N)} + \hat{D}_2\bar{z}^{(N)} \right] ds \\ + \left[C\bar{x}^{(N)} - \hat{D}_1\bar{y}^{(N)} - \hat{F}_2\bar{z}^{(N)} + \hat{D}_2^\top \bar{y}^{(N)} + \hat{D}_3\bar{z}^{(N)} \right] dW(s), \\ d\bar{y}^{(N)} = \left[-A^\top \bar{y}^{(N)} - C^\top \bar{z}^{(N)} - Q_1\bar{x}^{(N)} \right] ds + \bar{z}^{(N)} dW(s), \\ \bar{x}^{(N)}(S_{N-1}) = \xi_{N-1}, \quad \bar{y}^{(N)}(S_N) = G_1\bar{x}^{(N)}(S_N), \end{cases}$$

Furthermore,

$$J(s_{N-1}, \xi_{N-1}; \bar{u}|_{\mathcal{S}_N}, \bar{v}|_{\mathcal{S}_N}) = \mathbb{E}(\hat{p}_2^{(N)}(s_{N-1})\xi_{N-1}, \xi_{N-1}) = -K(s_{N-1}, \xi_{N-1}; \bar{u}|_{\mathcal{S}_N}, \bar{v}|_{\mathcal{S}_N}),$$

where

$$d\hat{p}_2^{(N)} = -(\hat{p}_2^{(N)}\mathbf{a}_2^{(N)} + (\mathbf{a}_2^{(N)})^\top \hat{p}_2^{(N)} + (\mathbf{b}_2^{(N)})^\top \hat{p}_2^{(N)}\mathbf{b}_2^{(N)} + \mathbf{q}_1)ds, \quad \hat{p}_2^{(N)}(T) = G_1.$$

$$\mathbf{a}_2^{(N)} = A - (\hat{B}_1 - \hat{B}_2)\Pi_1^{(N)} - (\hat{D}_1^\top - \hat{D}_2)(I + \Pi_1^{(N)}(\hat{F}_2 - \hat{D}_3))^{-1}(\Pi_1^{(N)}C - \Pi_1^{(N)}(\hat{D}_1 - \hat{D}_2^\top)\Pi_1^{(N)}),$$

$$\mathbf{b}_2^{(N)} = C - (\hat{D}_1 - \hat{D}_2^\top)\Pi_1^{(N)} - (\hat{F}_2 - \hat{D}_3)(I + \Pi_1^{(N)}(\hat{F}_2 - \hat{D}_3))^{-1}(\Pi_1^{(N)}C - \Pi_1^{(N)}(\hat{D}_1 - \hat{D}_2^\top)\Pi_1^{(N)}).$$

On \mathcal{S}_{N-1} , we have

$$\bar{u}|_{\mathcal{S}_{N-1}} = -R_{J,1}^{-1}(B_1^\top \Pi_1^{(N-1)} + D_1^\top (I + \Pi_1^{(N-1)}(\hat{F}_2 - \hat{D}_3))^{-1}(\Pi_1^{(N-1)}C - \Pi_1^{(N-1)}(\hat{D}_1 - \hat{D}_2^\top)\Pi_1^{(N-1)}))\bar{x}^{(N-1)},$$

$$\bar{v}|_{\mathcal{S}_{N-1}} = -R_{J,2}^{-1}(B_2^\top \Pi_1^{(N-1)} + D_2^\top (I + \Pi_1^{(N-1)}(\hat{F}_2 - \hat{D}_3))^{-1}(\Pi_1^{(N-1)}C - \Pi_1^{(N-1)}(\hat{D}_1 - \hat{D}_2^\top)\Pi_1^{(N-1)}))\bar{x}^{(N-1)}.$$

where

$$\begin{cases} \dot{\Pi}_1^{(N-1)} + \Pi_1^{(N-1)}A + A^\top \Pi_1^{(N-1)} - \Pi_1^{(N-1)}(\hat{B}_1 - \hat{B}_2)\Pi_1^{(N-1)} \\ - \Pi_1^{(N-1)}(\hat{D}_1^\top - \hat{D}_2)(I + \Pi_1^{(N-1)}(\hat{F}_2 - \hat{D}_3))^{-1}(\Pi_1^{(N-1)}C - \Pi_1^{(N-1)}(\hat{D}_1 - \hat{D}_2^\top)\Pi_1^{(N-1)}) \\ + C^\top (I + \Pi_1^{(N-1)}(\hat{F}_2 - \hat{D}_3))^{-1}(\Pi_1^{(N-1)}C - \Pi_1^{(N-1)}(\hat{D}_1 - \hat{D}_2^\top)\Pi_1^{(N-1)}) + Q_1 = 0, \\ \Pi_1^{(N-1)}(T) = \hat{p}_2^{(N)}(s_{N-1}), \end{cases}$$

and

$$\begin{cases} d\bar{x}^{(N-1)} = \left[A\bar{x}^{(N-1)} - \widehat{B}_1\bar{y}^{(N-1)} - \widehat{D}_1^\top \bar{z}^{(N-1)} + \widehat{B}_2\bar{y}^{(N-1)} + \widehat{D}_2\bar{z}^{(N-1)} \right] ds \\ \quad + \left[C\bar{x}^{(N-1)} - \widehat{D}_1\bar{y}^{(N-1)} - \widehat{F}_2\bar{z}^{(N-1)} + \widehat{D}_2^\top \bar{y}^{(N-1)} + \widehat{D}_3\bar{z}^{(N-1)} \right] dW(s), \\ d\bar{y}^{(N-1)} = \left[-A^\top \bar{y}^{(N-1)} - C^\top \bar{z}^{(N-1)} - Q_1\bar{x}^{(N-1)} \right] ds + \bar{z}^{(N-1)} dW(s), \\ \bar{x}^{(N-1)}(S_{N-2}) = \xi_{N-2}, \quad \bar{y}^{(N-1)}(S_{N-1}) = \widehat{p}_2^{(N)}(s_{N-1})\bar{x}^{(N-1)}(S_{N-1}). \end{cases}$$

Furthermore,

$$J(s_{N-2}, \xi_{N-2}; \bar{u}|_{\mathcal{S}_{N-1}}, \bar{v}|_{\mathcal{S}_{N-1}}) = \mathbb{E}\langle \widehat{p}_2^{(N-1)}(s_{N-2})\xi_{N-2}, \xi_{N-2} \rangle = -K(s_{N-2}, \xi_{N-2}; \bar{u}|_{\mathcal{S}_{N-1}}, \bar{v}|_{\mathcal{S}_{N-1}}),$$

where

$$\begin{cases} \dot{\widehat{p}}_2^{(N-1)} + \widehat{p}_2^{(N-1)}\mathbf{a}_2^{(N-1)} + (\mathbf{a}_2^{(N-1)})^\top \widehat{p}_2^{(N-1)} + (\mathbf{b}_2^{(N-1)})^\top \widehat{p}_2^{(N-1)}\mathbf{b}_2^{(N-1)} + \mathbf{q}_1 = 0, \\ \widehat{p}_2^{(N-1)}(S_{N-2}) = \widehat{p}_2^{(N)}(S_{N-1}), \end{cases} \quad (67)$$

$$\begin{aligned} \mathbf{a}_2^{(N-1)} &= A - (\widehat{B}_1 - \widehat{B}_2)\Pi_1^{(N-1)} \\ &\quad - (\widehat{D}_1^\top - \widehat{D}_2)(I + \Pi_1^{(N-1)}(\widehat{F}_2 - \widehat{D}_3))^{-1}(\Pi_1^{(N-1)}C - \Pi_1^{(N-1)}(\widehat{D}_1 - \widehat{D}_2^\top)\Pi_1^{(N-1)}), \\ \mathbf{b}_2^{(N-1)} &= C - (\widehat{D}_1 - \widehat{D}_2^\top)\Pi_1^{(N-1)} \\ &\quad - (\widehat{F}_2 - \widehat{D}_3)(I + \Pi_1^{(N-1)}(\widehat{F}_2 - \widehat{D}_3))^{-1}(\Pi_1^{(N-1)}C - \Pi_1^{(N-1)}(\widehat{D}_1 - \widehat{D}_2^\top)\Pi_1^{(N-1)}). \end{aligned}$$

Similar to (29), we have

$$\Pi_1^{(N)}(\cdot) = \widehat{p}_2^{(N)}(\cdot), \text{ on } \mathcal{S}_N.$$

Therefore,

$$\Pi_1^{(N-1)}(\cdot) = \widehat{p}_2^{(N-1)}(\cdot), \text{ on } \mathcal{S}_{N-1}.$$

Continuing the above process for $\mathcal{S}_{N-2}, \dots, \mathcal{S}_1$,

$$\Pi_1^{(i)}(\cdot) = \widehat{p}_2^{(i)}(\cdot), \text{ on } \mathcal{S}_i, \quad i = 1, \dots, N-2.$$

Therefore,

$$\Pi_1 = \Pi_1^{(1)} \oplus \dots \oplus \Pi_1^{(N)}, \quad \widehat{p}_2 = \widehat{p}_2^{(1)} \oplus \dots \oplus \widehat{p}_2^{(N)},$$

where Π_1 and \widehat{p}_2 are the Riccati equations (22) and (26) introduced for (SG₀) (see Proposition 13). Therefore, we get that (SG₀) and (SL₀) are equivalent.

6 Conclusion

In this paper, we give a unified framework to study two-person decision problems, i.e., stochastic (zero-sum, non zero-sum) Nash game, Stackelberg game with global information and Stackelberg game with local information. The solvability of above decision problems are established by abstract operator, Hamilton system and Riccati equations sequentially. Finally the relations among zero-sum Nash game, zero-sum Stackelberg game with global information and zero-sum Stackelberg game with local information are identified. The conclusions can be described by the following figure.

	Nash game	Stackelberg game with global information	Stackelberg game with local information	Relation
non zero-sum	time-consistent	time-inconsistent	time-inconsistent on $[t, T]$ but consistent at s_1, \dots, s_N	NG, SG, SL, are not equivalent
zero-sum	time-consistent	time-consistent	time-consistent	NG ₀ , SG ₀ , SL ₀ , are equivalent

References

1. T. Başar and G. J. Olsder. *Dynamic Noncooperative Game Theory*, Classics Appl. Math., SIAM, Philadelphia, 1999.
2. A. Bensoussan, S. Chen, A. Chutani and S. P. Sethi. Feedback Stackelberg-Nash equilibria in mixed leadership games with an application to cooperative advertising. *SIAM J. Control Optim.*, 57(2019), 3413-3444.
3. A. Bensoussan, S. Chen and S. P. Sethi. Linear quadratic differential games with mixed leadership: The open-loop solution, *Numerical Algebra, Control and Optimization*, 3(2013), 95-108.
4. A. Bensoussan, S. Chen and S. P. Sethi. The maximum principle for global solutions of stochastic Stackelberg differential games. *SIAM J. Control Optim.*, 53(2015), 1956-1981.
5. R. Buckdahn, P. Cardaliaguet, and C. Rainer. Nash equilibrium payoffs for nonzero-sum stochastic differential games, *SIAM J. Control Optim.*, 43(2004), 624-642.
6. R. Buckdahn and J. Li. Stochastic differential games and viscosity solutions of Hamilton-Jacobi-Bellman-Isaacs equations. *SIAM J. Control Optim.*, 47(2008), 444-475.
7. Chen L. and Shen Y. Stochastic Stackelberg differential reinsurance games under time-inconsistent mean-variance framework. *Insur. Math. Econ.*, 88(2019), 120-137.
8. W. H. Fleming and P. E. Souganidis. On the existence of value functions of two-player, zero-sum stochastic differential games, *Indiana Univ. Math. J.*, 38(1989), 293-314.
9. S. Hamadène. Backward-forward SDEs and stochastic differential games, *Stoch. Proc. Appl.*, 77(1998), 1-15.
10. S. Hamadène. Nonzero sum linear-quadratic stochastic differential games and backward-forward equations, *Stoch. Anal. Appl.*, 17(1999), 117-130.
11. T. Li and S. P. Sethi. A review of dynamic Stackelberg game models. *Discrete Contin. Dyn. Syst. Ser. B*, 22(2017), 125-159.
12. Y. Lin, X. Jiang and W. Zhang. An open-loop Stackelberg strategy for the linear quadratic mean-field stochastic differential game. *IEEE Trans. Automat. Contr.*, 64(2018), 97-110.
13. N. V. Long. *A Survey of Dynamic Games in Economics*. World Scientific, Singapore, 2010.
14. S. Maharjan, Q. Zhu, Y. Zhang, S. Gjessing and T. Başar. Dependable Demand Response Management in the Smart Grid: A Stackelberg Game Approach. *IEEE Trans. Smart Grid.*, 4(2013), 120-132.
15. J. Moon and T. Başar. Linear quadratic mean field Stackelberg differential games. *Automatica*, 97(2018), 200-213.
16. L. Mou and J. Yong. Two-person zero-sum linear quadratic stochastic differential games by a Hilbert space method. *J. Ind. Manag. Optim.*, 2(2006), 95-117.
17. B. Øksendal, L. Sandal and J. Ubøe. Stochastic Stackelberg equilibria with applications to time-dependent newsvendor models. *Journal of Economic Dynamics and Control*, 37(2013), 1284-1299.
18. S. J. Rubio, On coincidence of feedback Nash equilibria and Stackelberg equilibria in economic applications of differential games, *Journal of Optimization Theory and Applications*, 128(2006), 203-221.
19. H. von Stackelberg. *The Theory of the Market Economy*. Oxford Univ., New York (1952).
20. J. Shi, G. Wang and J. Xiong. Leader-follower stochastic differential game with asymmetric information and application. *Automatica*, 63(2016), 60-73.
21. J. Sun and J. Yong. Linear quadratic stochastic differential games: Open-loop and closed-loop saddle points, *SIAM J. Control Optim.*, 52(2014), 4082-4121.
22. J. Sun and J. Yong. Linear-quadratic stochastic two-person nonzero-sum differential games: Open-loop and closed-loop Nash equilibria. *Stoch. Proc. Appl.*, 219(2019), 381-418.
23. S. Tang. General linear quadratic optimal stochastic control problems with random coefficients: linear stochastic Hamilton systems and backward stochastic Riccati equations. *SIAM J. Control Optim.*, 42(2003), 53-75.
24. B. Wang and J. Zhang. Hierarchical mean field games for multiagent systems with tracking-type costs: distributed ε -Stackelberg equilibria. *IEEE Trans. Automat. Contr.*, 59(2017), 2241-2247.
25. J. Yong. A deterministic linear quadratic time-inconsistent optimal control problem. *Math. Control Relat. Fields*, 1(2011), 83-118.
26. J. Yong. A leader-follower stochastic linear quadratic differential game. *SIAM J. Control Optim.*, 41(2002), 1015-1041.
27. J. Yong and X. Y. Zhou. *Stochastic Controls: Hamiltonian Systems and HJB Equations*, Springer-Verlag, New York, 1999.
28. Z. Yu. An optimal feedback control-strategy pair for zero-sum linear-quadratic stochastic differential game: the Riccati equation approach, *SIAM J. Control Optim.*, 53(2015), 2141-2167.