



HAL
open science

Components in Meandric Systems and the Infinite Noodle

Valentin Féray, Paul Thévenin

► **To cite this version:**

Valentin Féray, Paul Thévenin. Components in Meandric Systems and the Infinite Noodle. International Mathematics Research Notices, 2022, 2023 (14), pp.12538-12560. 10.1093/imrn/rnac156 . hal-03797902

HAL Id: hal-03797902

<https://hal.science/hal-03797902v1>

Submitted on 6 Jan 2025

HAL is a multi-disciplinary open access archive for the deposit and dissemination of scientific research documents, whether they are published or not. The documents may come from teaching and research institutions in France or abroad, or from public or private research centers.

L'archive ouverte pluridisciplinaire **HAL**, est destinée au dépôt et à la diffusion de documents scientifiques de niveau recherche, publiés ou non, émanant des établissements d'enseignement et de recherche français ou étrangers, des laboratoires publics ou privés.



Distributed under a Creative Commons Attribution 4.0 International License

Components in Meandric Systems and the Infinite Noodle

Valentin Féray^{1,*} and Paul Thévenin²

¹Université de Lorraine, CNRS, IECL, F-54000 Nancy, France and

²Ångström Laboratory, Läagerhyddsvägen 1, 752 37 Uppsala, Sweden

*Correspondence to be sent to: e-mail: valentin.feray@univ-lorraine.fr

We investigate here the asymptotic behaviour of a large, typical meandric system. More precisely, we show the quenched local convergence of a random uniform meandric system \mathbf{M}_n on $2n$ points, as $n \rightarrow \infty$, towards the infinite noodle introduced by Curien *et al.* [3]. As a consequence, denoting by $cc(\mathbf{M}_n)$ the number of connected components of \mathbf{M}_n , we prove the convergence in probability of $cc(\mathbf{M}_n)/n$ to some constant κ , answering a question raised independently by Goulden–Nica–Puder [8] and Kargin [12]. This result also provides information on the asymptotic geometry of the Hasse diagram of the lattice of non-crossing partitions. Finally, we obtain expressions of the constant κ as infinite sums over meanders, which allows us to compute upper and lower approximations of κ .

1 Introduction

1.1 Background and main result

We study in this paper *meandric systems* of given size n , which are collections of non-crossing loops intersecting the horizontal axis exactly at the points $0, \dots, 2n - 1$ (up to continuous deformation fixing the horizontal axis). See Figure 1 for a simulation of a uniform meandric system of size 60.

Received January 27, 2022; Revised April 28, 2022; Accepted May 12, 2022
Communicated by Prof. Nathanael Berestycki

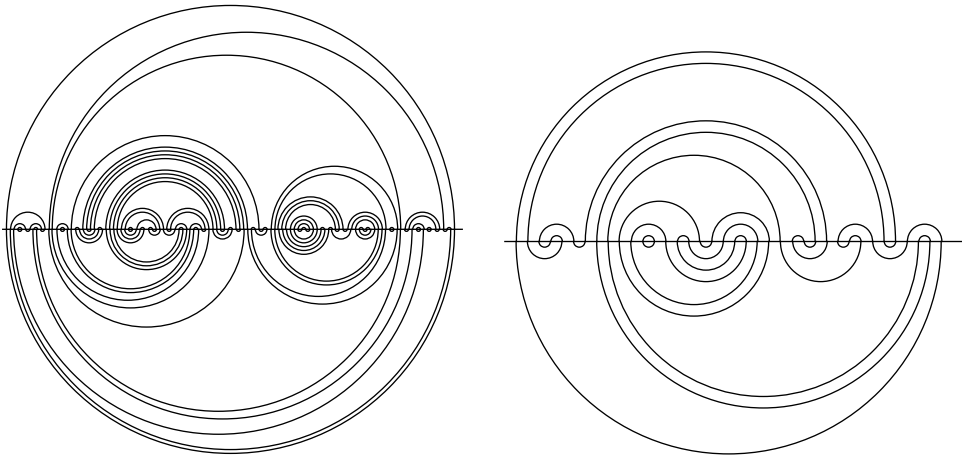

Fig. 1. Left: a uniform random meandric system of size 60. Right: a uniform random meandric system of size 20, with four connected components.

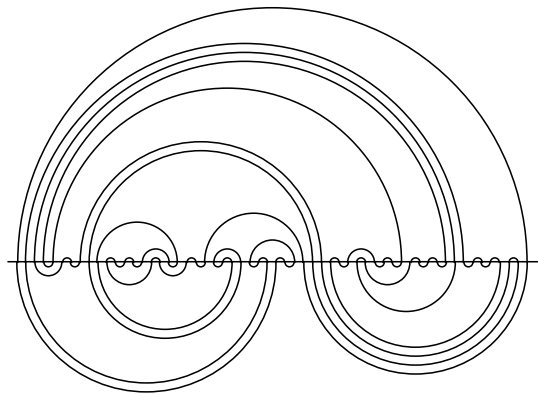

Fig. 2. A uniform random meander of size 30.

A meandric system consisting of only one loop is called a *meander* (see Figure 2). Their study can be traced back to Poincaré, and they are connected to different domains of mathematics, theoretical physics, or even biology, where they can be used as a model for polymer foldings [5].

Combinatorially, meandric systems can be uniquely represented as a pair of non-crossing pair-partitions; in particular, there are Cat_n^2 meandric systems of size n . On the contrary, the enumeration of meanders is a notoriously hard problem; see [17] for a survey on the topic and [6] for a remarkable conjecture on the critical exponent. Subclasses of meandric systems or meanders have been also (at least asymptotically)

enumerated, for example, meandric systems with a large number of connected components [7] or meanders with a given number of minimal arcs [4]. This raises connections respectively with free probability theory (see also [14]) and with the work of Mirzakhani about enumeration of geodesics on surfaces [13].

In this paper, we focus on another natural question: what is the number of connected components $\text{cc}(\mathbf{M}_n)$ of a uniform random (unconditioned) meandric system \mathbf{M}_n of size n ? This question has been raised recently, independently by Kargin [12] and Goulden–Nica–Puder [8]. Both sets of authors prove (through different methods) a linear lower bound for $\mathbb{E}[\text{cc}(\mathbf{M}_n)]$ and conjecture that the quotient $\mathbb{E}[\text{cc}(\mathbf{M}_n)]/n$ converges to a constant. We show here a stronger version of this conjecture, proving the convergence in probability of $\text{cc}(\mathbf{M}_n)/n$ towards a constant.

Theorem 1. Let \mathbf{M}_n be a uniform random meandric system of size n . Then there exists a constant $\kappa \in (0, 1)$ such that $\text{cc}(\mathbf{M}_n)/n \rightarrow \kappa$ in probability.

We note that Kargin [12] further conjectures that $\text{cc}(\mathbf{M}_n)$ is asymptotically normal with a variance linear in n , but we leave this problem open.

1.2 Quenched local convergence to the infinite noodle

A key step in our proof of Theorem 1 is the identification of the local limit of the uniform meandric system \mathbf{M}_n of size n . This limit turns out to be the so-called *infinite noodle* \mathbf{M}_∞ , introduced by Curien *et al.* [3] (the term *infinite noodle* refers to a hypothetical infinite component of the system in [3], while we use here this denomination for the whole (multi-)graph on \mathbb{Z} , independently of the existence of an infinite component). We recall here its construction. We first take two infinite sequences $(a_i)_{i \in \mathbb{Z}}$ and $(b_i)_{i \in \mathbb{Z}}$ of i.i.d. balanced random variables in $\{L, R\}$. Observe that there is a unique non-crossing pair-partition of \mathbb{Z} so that i is the left end of an arc if and only if $a_i = L$. We draw this non-crossing partition above the horizontal axis (“a” stands for “above”). Similarly, we construct another non-crossing partition from the sequence $(b_i)_{i \in \mathbb{Z}}$ and draw it below the horizontal axis (“b” stands for “below”). Taken together, the two matchings form a (multi-)graph on \mathbb{Z} ; we are interested in its connected components. In particular, it is proven in [3] that either there is exactly one infinite component a.s. or there is no infinite component a.s. The question of deciding which of these two statements holds is open.

We now come back to the connection with meandric systems. In Section 2, a notion of local convergence for meandric systems is introduced. The local convergence

of a uniform meandric system \mathbf{M}_n of size n to the infinite noodle is rather intuitive, and proved in Proposition 5 below, based on some known results for conditioned random walks [2, 9]. This convergence holds in a strong sense, namely in the quenched setting (see Section 2 for a definition). Roughly speaking, it says that, for any k fixed, the k -neighbourhood of a uniform point in a fixed typical meandric system \mathbf{M}_n of size n converges in distribution to the k -neighbourhood of 0 in \mathbf{M}_∞ .

As said above, this quenched local convergence result is central in our proof of Theorem 1. In fact, the constant κ has a natural expression in terms of the infinite noodle:

$$\kappa = \mathbb{E} \left[\frac{2}{|C_0(\mathbf{M}_\infty)|} \right], \tag{1}$$

where $|C_0(\mathbf{M}_\infty)|$ is the size of the component containing 0 in \mathbf{M}_∞ (with the convention $2/\infty = 0$). We note that it is not known whether this component is finite a.s.; this is equivalent to the fact that the infinite noodle has no infinite component a.s., which, as we said before, is still an open question.

Based on this probabilistic interpretation, in Section 4, we give two formulas for κ , as infinite sums over meanders of all sizes and closely related objects (open meanders). Truncating these sums to finite index sets yields rigorous lower and upper bounds for κ . With the aid of a computer software, we can prove that κ is in the interval $[0.207, 0.292]$, improving on the bounds 0.17 and 0.5 given in [8] (computational experiments suggest that the true value should be around 0.23; see again [8] or [12]).

1.3 Asymptotic geometry of the Hasse diagram of the lattice of non-crossing partitions

We now discuss a geometric consequence of our result, regarding non-crossing partitions. For brevity, we will not recall all definitions in the introduction. The reader unfamiliar with non-crossing partitions may look at Appendix A or [8] for the relevant definitions. We denote by $\text{NC}(n)$ the poset of non-crossing partitions of size n , with the refinement order. Considering the Hasse diagram (i.e., the graph of covering relations) of this poset endows the set $\text{NC}(n)$ with a graph structure; we will denote this graph by \mathcal{H}_n .

It turns out that distances in this graph can be understood through meandric systems. Indeed, in [8], the authors construct a bijection M from $\text{NC}(n)^2$ onto the set of meandric systems of size n such that, for all $\rho, \pi \in \text{NC}(n)$,

$$d_{\mathcal{H}_n}(\rho, \pi) = n - \text{cc}(M(\rho, \pi)).$$

We refer to Appendix A for a short informal description of the bijection. Hence, Theorem 1 is equivalent to the following statement.

Proposition 2. For each n , let ρ_n and π_n be independent uniformly distributed elements in $\text{NC}(n)$. As n tends to infinity, the quantity $\frac{1}{n}d_{\mathcal{H}_n}(\rho_n, \pi_n)$ converges in probability to $1 - \kappa$.

In other words, in the rescaled graph $(\mathcal{H}_n, n^{-1}d_{\mathcal{H}_n})$, asymptotically almost all pairs of points are at the same distance $1 - \kappa$ from each other. We note that this kind of phenomena, where asymptotically all pairs of points are at the same distance of each other, occurs in many other natural models of (random) discrete measured spaces: for examples in hypercubes of growing dimensions or in models of random trees of logarithmic height [10, Sections 12–14].

Remark 3. To understand further the asymptotic geometry of $\text{NC}(n)$, a natural question is to study the distance to a fixed particular element, for example the partition $\mathbf{0}_n$ in singletons (i.e., the minimal element of $\text{NC}(n)$). Letting ρ_n a uniform random element in $\text{NC}(n)$, one can prove that $\frac{1}{n}d_{\mathcal{H}_n}(\rho_n, \mathbf{0}_n)$ converges to $1/2$ in probability. Hence, $\mathbf{0}_n$ is not a typical element in $\text{NC}(n)$. The same holds replacing $\mathbf{0}_n$ by the one-block partition $\mathbf{1}_n$ by symmetry (recalling that $\text{NC}(n)$ is self-dual). Here, we see a difference with the asymptotic geometry of random tree models with logarithmic height, where the distance to the root is typically half the distance between two random points, and of hypercubes, where the typical distance to the root is the same as between two uniform random vertices.

1.4 Combinatorial definition of meandric systems

A matching of size n is a partition of the set $\{0, \dots, 2n - 1\}$ into sets of size 2. It is customary to represent a matching P as a set of arcs all on the same side of a horizontal line, with an arc connecting i to j for each pair $\{i, j\}$ in P . A matching is non-crossing if the corresponding set of arcs does not contain any crossing, that is, if there does not exist two pairs $\{i, k\}$ and $\{j, \ell\}$ in P , with $i < j < k < \ell$. It is well known that there are Cat_n matchings of size n , where $\binom{\text{Cat}_n}{2nn} := \frac{1}{n+1}$ is the n -th Catalan number.

It is easy to see that a meandric system M of size n can be uniquely represented as a pair of non-crossing matchings of the same size, drawn respectively above and below the same horizontal line. Consequently, there are exactly Cat_n^2 meandric systems of size n . Considering both non-crossing matchings together gives a (multi-)graph

structure on $\{0, \dots, 2n-1\}$ and we denote by $\text{cc}(M)$ the number of connected components of this graph. It corresponds to the number of loops when we see the meandric system as a collection of non-crossing loops intersecting the horizontal axis exactly at positions $0, \dots, 2n-1$.

1.5 Organization of the paper

We show in Section 2 the local convergence of a random uniform meandric system to the infinite noodle (Proposition 5). We then use this result to prove Theorem 1 in Section 3. Section 4 is devoted to the proof of two ways of writing the constant κ of Theorem 1, whose computation provides upper and lower bounds for its value. Finally, Appendix A provides definitions used in Proposition 2.

1.6 Notation

In the whole paper, $\xrightarrow{(d)}$ will denote the convergence in distribution of a sequence of random variables, and $\xrightarrow{\mathbb{P}}$ the convergence in probability.

2 Quenched Local Convergence of a Uniform Meandric System

The goal of this section is to prove the convergence of a uniform meandric system of size n , in the so-called *quenched Benjamini–Schramm sense*, towards the infinite noodle introduced by Curien *et al.* [3]. The proof of this result consists in encoding a meandric system by conditioned random paths, for which results of local convergence have been established [2, 9].

2.1 Local topology on meandric systems

Let us define a local topology on meandric systems with a marked point. To this end, we introduce the notion of partial matchings and partial meandric systems.

Let A be an integer interval (finite or infinite). A partial matching on A is a partition of A into pairs and singletons, where singletons are decorated with either L or R . We represent partial matchings with a set of arcs, where pairs are treated as above and a singleton $\{i\}$ decorated with L (resp. R) is represented by a dashed unbounded open arc, whose left end (resp. right end) is i . A partial matching is *non-crossing* if it does not contain any of the following configurations (see Figure 3):

- two pairs $\{i, k\}$ and $\{j, \ell\}$, with $i < j < k < \ell$;

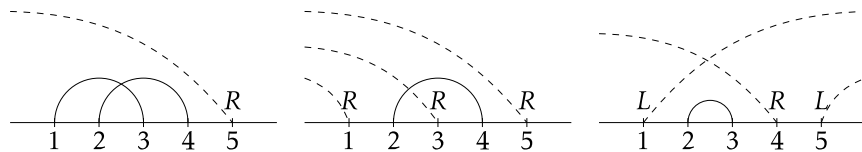

Fig. 3. The three forbidden configurations in a non-crossing partial matching of the interval $\llbracket 1, 5 \rrbracket$.

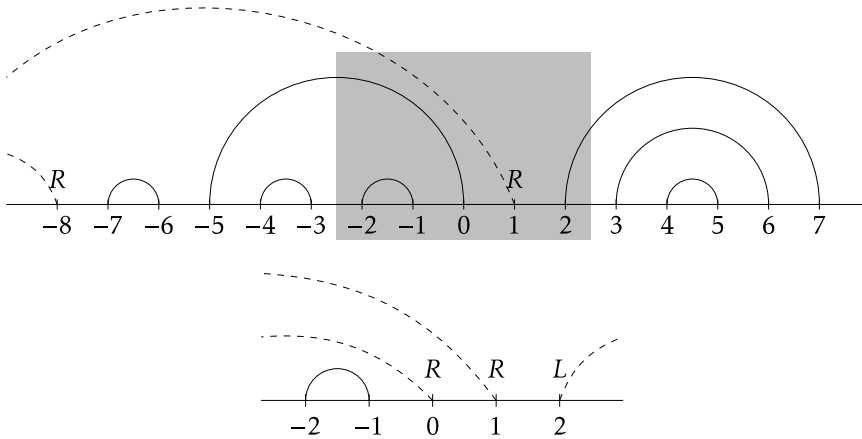

Fig. 4. A partial matching on $\llbracket -8, 7 \rrbracket$ and its restriction to $\llbracket -2, 2 \rrbracket$.

- a pair $\{i, k\}$ and a singleton $\{j\}$ with $i < j < k$ (regardless of the decoration of $\{j\}$);
- two singletons $\{i\}$ and $\{j\}$ with $i < j$ where i is decorated with L and j with R .

A partial meandric system is then a pair of two non-crossing partial matchings of the same interval, drawn respectively above and below the same horizontal line. Components in partial meandric systems are defined similarly as in meandric systems. We will sometimes refer to meandric systems as *complete* meandric systems to emphasize the opposition to partial ones.

If B is a subinterval of A and P a partial matching on A , there is a natural notion of restriction P/B . Namely, we keep only pairs and singletons of P containing elements in B . If a pair $\{i, i'\}$ of P contains one element of B and one not in B , say i is in B but not i' , then P/B contains $\{i\}$ as a singleton, decorated either with L (if $i' > i$) or with R (if $i' < i$). See Figure 4. Subsequently, we define the restriction M/B of a partial meandric system M on A by taking the restrictions to B of the two partial matchings of M .

A marked (partial) meandric system is a pair (M, r) , where M is a (partial) meandric system of some integer interval A (possibly infinite) and r an element of A . We denote by \mathbb{M}_{part} the set of marked partial meandric systems. Two marked partial meandric systems (M_1, r_1) and (M_2, r_2) are equivalent if they differ by a shift: we write $(M_1, r_1) \equiv (M_2, r_2)$. Furthermore, we define a distance between two marked partial meandric systems as follows:

$$d((M_1, r_1), (M_2, r_2)) = \frac{1}{1 + \max\{k : M_1/[r_1 - k; r_1 + k] \equiv M_2/[r_2 - k; r_2 + k]\}}$$

with the convention that $d((M_1, r_1), (M_2, r_2)) = 0$ if they are equivalent and 1 if $M_1/\{r_1\} \neq M_2/\{r_2\}$. With this distance, marked partial meandric systems, up to equivalence, form a compact Polish space.

2.2 Benjamini–Schramm convergence

In graph theory, we say that a (deterministic) sequence of graphs $(G_n)_{n \geq 1}$ converges in the Benjamini–Schramm sense—also known as local weak convergence—if the sequence of random rooted graphs (G_n, v_n) converges for the local topology, where for each n , v_n is a uniform random vertex of G_n . This notion has first appeared in [1] and has been largely used since then. When the sequence of graphs (G_n) is random, there are two natural extensions.

- Either we consider the pair (G_n, v_n) , where v_n is a uniform random vertex of G_n , as a random rooted graph and we look at its limit in distribution. In this case, we speak of *annealed Benjamini–Schramm convergence*.
- Or we consider the conditional law $\mathcal{L}((G_n, v_n)|G_n)$, which is a random measure on the set of rooted graphs. If this random measure converges weakly in distribution, we speak of *quenched Benjamini–Schramm convergence*.

We will borrow this terminology in the setting of matchings and define a notion of quenched Benjamini–Schramm convergence. In the latter, we use the notation \mathcal{L} for the (conditional) law of a random variable.

Definition 4. A sequence of random partial meandric systems $(M_n)_{n \geq 1}$ converges in the quenched Benjamini–Schramm sense if, letting i_n be a uniform random element of

\mathbf{M}_n (chosen independently of \mathbf{M}_n), we have in distribution

$$\mathcal{L}((\mathbf{M}_n, \mathbf{i}_n) | \mathbf{M}_n) \xrightarrow[n \rightarrow \infty]{\text{weakly}} \mu,$$

where μ is a random measure on the set of marked partial meandric systems. Equivalently, it means that, for any bounded continuous function $F : (\mathbb{M}_{\text{part}}, \mathcal{d}) \rightarrow \mathbb{R}_+$, we have

$$\mathbb{E}[F(\mathbf{M}_n, \mathbf{i}_n) | \mathbf{M}_n] \xrightarrow[n \rightarrow \infty]{(d)} \int_{\mathbb{M}_{\text{part}}} F(M, r) \, d\mu(M, r).$$

To avoid dealing with random measures, we use mostly the 2nd definition. Remark moreover that, in the case of interest for us, the limiting measure is a.s. equal to the law of the infinite noodle, so that for all F ,

$$\int_{\mathbb{M}_{\text{part}}} F(M, r) \, d\mu(M, r) = \mathbb{E}[F(\mathbf{M}_\infty, 0)]$$

is a deterministic quantity.

2.3 Convergence of a uniform meandric system

We prove here the following result, showing the quenched Benjamini–Schramm convergence of a uniform meandric system of size n towards the infinite noodle \mathbf{M}_∞ .

Proposition 5. A uniform random meandric system \mathbf{M}_n of size n converges in the quenched Benjamini–Schramm sense to the law of the infinite noodle $(\mathbf{M}_\infty, 0)$, that is, for any bounded continuous function $F : (\mathbb{M}_{\text{part}}, \mathcal{d}) \rightarrow \mathbb{R}_+$, one has

$$\mathbb{E}[F(\mathbf{M}_n, \mathbf{i}_n) | \mathbf{M}_n] \xrightarrow[n \rightarrow \infty]{\mathbb{P}} \mathbb{E}[F(\mathbf{M}_\infty, 0)].$$

Since the right-hand side is a constant, observe that it is equivalent to the convergence in distribution towards the same quantity. The proof is based on an straightforward encoding of meandric systems, as pairs of well-parenthesized words, which we now describe.

Let P be a partial non-crossing matching on an integer interval A . We associate with it a function $w : A \rightarrow \{L, R\}$ as follows: $w(i) = L$ if and only if $\{i\}$ is a singleton of P decorated with L or if i is the smallest element in its pair. Such functions will be called *words* in the sequel. The following lemma is elementary.

Lemma 6. This function w defines a bijection from partial non-crossing matchings on A to $\{L, R\}^A$, compatible with restriction. Moreover, for a finite interval A , a partial non-crossing matching is complete (i.e., does not contain singletons) if and only if the associated word is a well-parenthesized word (i.e., it has as many L s as R s and all its prefixes have at least as many L s as R s).

Using this correspondence, partial meandric systems are mapped to pairs (w^a, w^b) of words in $\{L, R\}^A$. A pair (w, r) , where w is a word in $\{L, R\}^A$, and r a point in A will be called a marked word. Marked words are considered equivalent if they differ only by a simultaneous shift of the domain set A and of the marked point r . We can define a natural distance between marked words (w_1, r_1) and (w_2, r_2) as follows:

$$D((w_1, r_1), (w_2, r_2)) = \frac{1}{1 + \max\{k : w_1/[r_1 - k; r_1 + k] \equiv w_2/[r_2 - k; r_2 + k]\}},$$

again with the convention that $D((w_1, r_1), (w_2, r_2)) = 0$ if they are equivalent and 1 if $w_1(r_1) \neq w_2(r_2)$. Again, this defines a compact metric space, which we denote \mathcal{W}_* .

We recall that the infinite noodle \mathbf{M}_∞ is the meandric system on \mathbb{Z} corresponding to random words $\mathbf{w}_\infty^a, \mathbf{w}_\infty^b$, where all images $\mathbf{w}_\infty^a(i)$ ($i \in \mathbb{Z}$) and $\mathbf{w}_\infty^b(j)$ ($j \in \mathbb{Z}$) are uniform in $\{L, R\}$ and independent of each other. On the other hand, a uniform meandric system \mathbf{M}_n of size n corresponds to independent uniform well-parenthesized words $\mathbf{w}_n^a, \mathbf{w}_n^b$. Since the bijection between partial matchings/meandric systems and words commutes with restriction, Proposition 5 is equivalent to the following proposition.

Proposition 7. A uniform random well-parenthesized word \mathbf{w}_n on $\{0, \dots, n - 1\}$ converges in the quenched Benjamini–Schramm sense to the law of a random word \mathbf{w}_∞ , whose images $(\mathbf{w}_\infty(i))_{i \in \mathbb{Z}}$ are uniform in $\{L, R\}$ and independent of each other. In other words, for any bounded continuous function $F : \mathcal{W}_* \rightarrow \mathbb{R}_+$, we have

$$\mathbb{E} [F(\mathbf{w}_n, \mathbf{i}_n) | \mathbf{w}_n] \xrightarrow[n \rightarrow \infty]{\mathbb{P}} \mathbb{E}[F(\mathbf{w}_\infty, 0)], \tag{2}$$

where \mathbf{i}_n denotes a uniform element of $\{0, \dots, n - 1\}$.

Proof. As in the case of Proposition 5, it is enough to prove this convergence in distribution. We first consider the case where F depends only on the restriction of w to a fixed size neighbourhood of r , say $F(w, r) = g(w(r - k), \dots, w(r + k))$ (we call such a

function a local function). Then,

$$\mathbb{E}[F(\mathbf{w}_n, \mathbf{i}_n) | \mathbf{w}_n] = \frac{1}{n} \sum_{r=k}^{n-k-1} g(\mathbf{w}_n(r-k), \dots, \mathbf{w}_n(r+k)) + O(1/n),$$

where the error term comes from boundary effect. Taking \mathbf{w}_n uniformly at random among all well-parenthesized word on $\{0, \dots, n-1\}$ amounts to consider a simple random walk conditioned to come back at 0 at time $n-1$ and be nonnegative between 0 and $n-1$ (simply replace L by $+1$ and R by -1). In this context, it is known that

$$\frac{1}{n} \sum_{r=k}^{n-k-1} g(\mathbf{w}_n(r-k), \dots, \mathbf{w}_n(r+k))$$

converges in probability to

$$\mathbb{E}[g(\zeta_1, \dots, \zeta_{2k+1})],$$

where $(\zeta_1, \dots, \zeta_{2k+1})$ are i.i.d. random variables uniform in $\{-1; 1\}$ (or in $\{L, R\}$): see [2, Proposition 2.2] for an asymptotic normality result implying this convergence in probability (Borga's result is itself based on [9, Lemma 6.1]). Since

$$\mathbb{E}[F(\mathbf{w}_\infty, 0)] = \mathbb{E}[g(\zeta_1, \dots, \zeta_{2k+1})],$$

this proves (2) for any *local* function F .

The general case follows by standard arguments, approximating F by local functions. Here are the details. We consider a general continuous function $F : \mathcal{W}_* \rightarrow \mathbb{R}_+$. Since \mathcal{W}_* is compact, F is uniformly continuous. For $k \geq 1$, we set $F_k(w, r) = F(w/[r-k; r+k], r)$. We note that

$$D((w, r), (w/[r-k; r+k], r)) \leq 1/(k+1).$$

This bound is uniform on (w, r) and implies, using the uniform continuity of F , that F_k tends uniformly to F . We then write: a.s., it holds that

$$\begin{aligned} \left| \mathbb{E}[F(\mathbf{w}_n, \mathbf{i}_n) | \mathbf{w}_n] - \mathbb{E}[F(\mathbf{w}_\infty, 0)] \right| &\leq \left| \mathbb{E}[F(\mathbf{w}_n, \mathbf{i}_n) | \mathbf{w}_n] - \mathbb{E}[F_k(\mathbf{w}_n, \mathbf{i}_n) | \mathbf{w}_n] \right| \\ &+ \left| \mathbb{E}[F_k(\mathbf{w}_n, \mathbf{i}_n) | \mathbf{w}_n] - \mathbb{E}[F_k(\mathbf{w}_\infty, 0)] \right| + \left| \mathbb{E}[F_k(\mathbf{w}_\infty, 0)] - \mathbb{E}[F(\mathbf{w}_\infty, 0)] \right|. \quad (3) \end{aligned}$$

Fix $\varepsilon > 0$. Using the uniform convergence of F_k to F , we can find k such that the 1st and 3rd terms are at most ε (a.s. for the 1st term, which is a random variable). But, for this value of k , the 2nd term converges to 0 in probability, since we know that (2) holds for the local function F_k . We conclude that the left-hand side of (3) tends to 0 in probability, as wanted. ■

3 Proof of Theorem 1

We prove here our main result, Theorem 1, using Proposition 5. Indeed, it turns out that the number of connected components $cc(M)$ of a meander M can be expressed as the expectation of a functional of (M, i) , where i is a random element of M . To this end, if M is a meandric system of size n and i an integer in $\{0, \dots, 2n - 1\}$, we denote by $|C_i(M)|$ the size of the connected component $C_i(M)$ of M containing i .

Lemma 8. Let M be a meandric system of size n and i_n a uniform random integer in $\{0, \dots, 2n - 1\}$. Then $\frac{cc(M)}{n} = \mathbb{E}\left[\frac{2}{|C_{i_n}(M)|}\right]$.

Proof. Since i_n is uniformly distributed, we have

$$\mathbb{E}\left[\frac{2}{|C_{i_n}(M)|}\right] = \frac{2}{2n} \sum_{i=0}^{2n-1} \frac{1}{|C_i(M)|}.$$

Let C be a connected component of M . Each i in C contributes $1/|C|$ to the above sum, so that all of them together contribute 1 to the sum. Since this holds for all connected components of M , the value of the sum is simply the number of connected components of M , proving the lemma. ■

We consider the following function on the set \mathbb{M}_{part} of marked partial meandric systems: $IS(M, r) := \frac{1}{|C_r(M)|}$ (IS stands for “inverse size”). Though not continuous on the whole space \mathbb{M}_{part} , this function has a nice continuity set.

Lemma 9. The functional IS is continuous at any *complete* meandric system.

Proof. Consider a sequence $(M_j, r_j)_{j \geq 1}$ converging to a *complete* meandric system (M, r) . We want to prove that

$$\lim_{j \rightarrow +\infty} IS(M_j, r_j) = IS(M, r). \tag{4}$$

Assume first that the component $C_r(M)$ is finite. Then, since M is complete, $C_r(M)$ is a loop. Let us denote by k the longest distance between a point of $C_r(M)$ and r . For j large enough, we have $M_j/[r_j - k; r_j + k] = M/[r - k; r + k]$. The latter contains entirely $C_r(M)$. We conclude that for j large enough, $C_{r_j}(M_j)$ is also a loop and has the same cardinality as $C_r(M)$. Hence, $\text{IS}(M_j, r_j) = \text{IS}(M, r)$, proving (4) in the finite component case.

Assume now that $C_r(M)$ is infinite, so that $\text{IS}(M, r) = 0$. We fix an integer $m > 0$. We can choose k such that the component of r in $M \cap [r - k; r + k]$ has at least m points. For j large enough $M_j/[r_j - k; r_j + k] = M/[r - k; r + k]$, so that the connected component of r_j in M_j contains at least m points, that is, $\text{IS}(M_j, r_j) \leq 1/m$. Since m was arbitrary, we have $\lim_{j \rightarrow +\infty} \text{IS}(M_j, r_j) = 0$, proving (4) in the infinite component case. ■

We can now prove our main theorem.

Proof of Theorem 1. Using Proposition 5 along with [11, Theorem 4.11], we know that the sequence of random measures $\mathcal{L}((\mathbf{M}_n, \mathbf{i}_n) | \mathbf{M}_n)$ converges in distribution for the vague topology towards the law of the infinite noodle $\mathcal{L}(\mathbf{M}_\infty, 0)$. Thus, by [11, Lemma 4.12], we have

$$\mathbb{E}[\text{IS}(\mathbf{M}_n, \mathbf{i}_n) | \mathbf{M}_n] \xrightarrow[n \rightarrow \infty]{\mathbb{P}} \mathbb{E}[\text{IS}(\mathbf{M}_\infty, 0)], \quad (5)$$

provided that the set of discontinuity of IS is negligible under the limiting measure $\mathcal{L}(\mathbf{M}_\infty, 0)$. By Lemma 9, it is enough to prove that \mathbf{M}_∞ is a.s. a complete meandric system. Assume without loss of generality that $w_\infty^a(0) = L$. Then, again with the convention that $L = 1$ and $R = -1$, the random walk $(w_\infty^a(i))_{i \geq 1}$ is a.s. recurrent. Let $j := \inf\{i \geq 1, \sum_{k=1}^i w_k^a = -1\}$. Then $j < \infty$ a.s., and 0 and j are connected by an arc in the upper half-plane. The same works in the lower half-plane and, therefore, there is a.s. no singleton in \mathbf{M}_∞ and \mathbf{M}_∞ is a.s. complete. This proves Equation (5). By Lemma 8, the left-hand side of Equation (5) is $\frac{1}{2n} \text{cc}(\mathbf{M}_n)$, while κ is twice the right-hand side (see (1)). Therefore, we have proved that $\frac{1}{n} \text{cc}(\mathbf{M}_n)$ converges in probability to κ . ■

4 Two Formulas for κ

It is possible to write the limiting constant κ of Theorem 1 in different ways. This allows in particular to bound from above and from below the value of this constant.

4.1 Lower bounds

Given a realization of the infinite noodle \mathbf{M}_∞ , we will define the *shape* S_0 of the component $C_0(\mathbf{M}_\infty)$ containing 0. To obtain this shape, let $E \subset \mathbb{Z}$ be the set of points

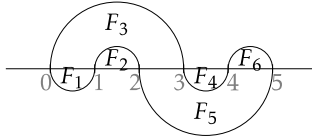

Fig. 5. A meander with six faces. In this example, we have $I(F_1) = \{0\}$, $I(F_2) = \{1\}$, $I(F_3) = \{0, 2\}$, $I(F_4) = \{3\}$, $I(F_5) = \{2, 4\}$, and $I(F_6) = \{4\}$.

of $C_0(\mathbf{M}_\infty)$, and let $(\mathbf{w}_\infty^a, \mathbf{w}_\infty^b)$ be the words in $\{L, R\}^{\mathbb{Z}}$ describing \mathbf{M}_∞ . Assuming E is finite, there exists a unique increasing bijection $g : E \rightarrow \llbracket 0, |E| - 1 \rrbracket$. The shape is the meandric system of size $|E|/2$ obtained from the pair $(\mathbf{w}^a, \mathbf{w}^b)$ on $\{L, R\}^{|E|}$ such that, for all $0 \leq i \leq |E| - 1$, $\mathbf{w}^a(i) = \mathbf{w}_\infty^a(g^{-1}(i))$ and $\mathbf{w}^b(i) = \mathbf{w}_\infty^b(g^{-1}(i))$. In particular, S_0 is a meandric system with only one connected component, that is, a meander. It is therefore possible to write

$$\kappa = \sum_{k=1}^{\infty} \frac{1}{k} \sum_{C \in M^{(1),k}} \mathbb{P}(S_0 = C), \tag{6}$$

where $M^{(1),k}$ is the set of meanders of size k (recall that they are defined on $\{0, \dots, 2k-1\}$). The interest of this formula is that, the meander C being fixed, it is possible to compute $\mathbb{P}(S_0 = C)$. To this end, we introduce some terminology. Let C be a meander of size k . We consider the union of C and the real axis; it divides the plane in some regions, two unbounded ones and several bounded ones. We call such bounded regions *faces* of the meander and denote their set by $\mathcal{F}(C)$. A face F in $\mathcal{F}(C)$ is incident to a number of segments $[i; i + 1]$; we let $I(F)$ be the set of indices i such that F is incident to $[i; i + 1]$. A meander with six faces and the corresponding index sets are shown on Figure 5. With this notation, we have the following.

Proposition 10. For any meander C of size k , we have

$$\mathbb{P}(S_0 = C) = 2^{-4k+1} k \sum_{\ell_1, \dots, \ell_{2k-1} \geq 0} \left(\prod_{F \in \mathcal{F}(C)} \text{Cat}_{\ell_{I(F)}} 2^{-2\ell_{I(F)}} \right), \tag{7}$$

where, for a set I of indices, we use the notation $\ell_I = \sum_{i \in I} \ell_i$.

Proof. Fix a meander C of size k . For $1 \leq i \leq 2k$, we call A_i the event “0 is the i -th smallest point in $C_0(\mathbf{M}_\infty)$ ”. We clearly have

$$\mathbb{P}(S_0 = C) = \sum_{i=1}^{2k} \mathbb{P}[(S_0 = C) \wedge A_i].$$

By translation invariance of the model, the summands in the right-hand side are all equal and

$$\mathbb{P}(S_0 = C) = 2k \mathbb{P}[(S_0 = C) \wedge A_1]. \tag{8}$$

We split the event $\{(S_0 = C) \wedge A_1\}$, depending on the set of points E of $C_0(\mathbf{M}_\infty)$. Under the event $\{(S_0 = C) \wedge A_1\}$, we have $|E| = 2k$ and $\min(E) = 0$, so that

$$E = \{0, m_1 + 1, m_1 + m_2 + 2, \dots, m_1 + \dots + m_{2k-1} + 2k - 1\},$$

for some integers $m_1, m_2, \dots, m_{2k-1} \geq 0$; in other words, m_i is the number of empty places (i.e., integers that do not belong to S_0) between the i -th and $i+1$ st elements of E . Necessarily, each m_i must be even: indeed, since C_0 is connected, any other component of the meandric system must cross the segment between the i -th and the $i+1$ st point of E an even number of times. We therefore write $m_i = 2\ell_i$ for integers $\ell_1, \ell_2, \dots, \ell_{2k-1} \geq 0$.

Fixing some integers $\ell_1, \ell_2, \dots, \ell_{2k-1} \geq 0$, we compute the probability of the event

$$(S_0 = C) \wedge A_1 \wedge (E = \{0, m_1 + 1, m_1 + m_2 + 2, \dots, m_1 + \dots + m_{2k-1} + 2k - 1\}). \tag{9}$$

We claim that the probability of this event is given by

$$2^{-4k} \prod_{F \in \mathcal{C}} \text{Cat}_{\ell_{I(F)}} 2^{-2\ell_{I(F)}}. \tag{10}$$

To avoid complicated notation, we will prove this formula on an example. We consider the meander drawn on Figure 5. We recall that the infinite noodle is constructed from two independent random words \mathbf{w}_∞^a and \mathbf{w}_∞^b in the alphabet $\{L, R\}$ (the upper and lower words below; we shall also think of L and R as arrows pointing to the left or right, when convenient). Then the event (9) holds if and only if the words \mathbf{w}_∞^a and \mathbf{w}_∞^b satisfy the following properties.

- All upper and lower arrows at points $\{0, m_1 + 1, m_1 + m_2 + 2, \dots, m_1 + \dots + m_{2k-1} + 2k - 1\}$ should be pointing in a specific direction so that the infinite

noodle restricted to this set can have shape C . In our example, it means that at 0, both arrows should point to the right, at $m_1 + 1$, the upper arrow points to the right, and the lower to the left and so on . . . This happens with probability 2^{-4k} (here $k = 3$).

- To have an arc in the lower matching between 0 and $m_1 + 1$, we need to have a well-parenthesized word in L and R at positions $\{1, \dots, m_1\}$ in the lower word \mathbf{w}_∞^b . This happens with probability $\text{Cat}_{\ell_1} 2^{-2\ell_1}$, where $m_1 = 2\ell_1$. Similarly, to have $m_1 + 1$ and $m_1 + m_2 + 2$ connected in the upper matching, we need to have a well-parenthesized word in L and R at positions $\{m_1 + 2, \dots, m_1 + m_2 + 1\}$. This happens with probability $\text{Cat}_{\ell_2} 2^{-2\ell_2}$. Conditioning on having an arc between $m_1 + 1$ and $m_1 + m_2 + 2$ in the upper matching, we also want 0 and $m_1 + m_2 + m_3 + 3$ to be connected. This happens if and only if the restriction of \mathbf{w}_∞^a to

$$\{1, \dots, m_1, m_1 + m_2 + 3, \dots, m_1 + m_2 + m_3 + 2\}$$

is well parenthesized; this is an event of probability $\text{Cat}_{\ell_1 + \ell_3} 2^{-2\ell_1 - 2\ell_3}$. Continuing this way, we see that we get one term $\text{Cat}_{\ell_{I(F)}} 2^{-2\ell_{I(F)}}$ for each face F of the matching.

This proves that the probability of the event (9) is indeed given by (10) and ends the proof of the lemma. ■

Using the lemma and Mathematica to evaluate the infinite sums, it is possible to evaluate $\mathbb{P}(S_0 = C)$ for simple meanders.

- For  (which is the only meander of size 2), we have

$$\mathbb{P}(S_0 = C) = \frac{1}{8} \sum_{\ell=0}^{\infty} \text{Cat}_\ell^2 2^{-4\ell} = \frac{2}{\pi} - \frac{1}{2} \approx 0.137.$$

- For  (which is the only meander of size 4, up to vertical symmetry), we have

$$\begin{aligned} \mathbb{P}(S_0 = C) &= \frac{1}{64} \cdot \left(\sum_{\ell_2 \geq 0} \text{Cat}_{\ell_2} 2^{-2\ell_2} \right) \cdot \left(\sum_{\ell_1, \ell_3 \geq 0} \text{Cat}_{\ell_1} \text{Cat}_{\ell_3} \text{Cat}_{\ell_1 + \ell_3} 2^{-4\ell_1 - 4\ell_3} \right) \\ &= \frac{1}{64} \cdot 2 \cdot \left(8 - \frac{64}{3\pi} \right) = \frac{1}{4} - \frac{2}{3\pi} \approx 0.038. \end{aligned} \tag{11}$$

Probabilities $\mathbb{P}(S_0 = C)$ for larger meanders C do not seem to have such compact expressions in $\mathbb{Q}(\pi)$.

Remark 11. The factorization occurring in Equation (11) is an instance of a general fact. Indeed, each face F of a meander C contains either only even numbers or only odd numbers. We write $\mathcal{F}_e(C)$ and $\mathcal{F}_o(C)$ for the sets of faces of C with even and odd numbers, respectively. We have

$$\sum_{\ell_1, \dots, \ell_{2k-1} \geq 0} \left(\prod_{F \in \mathcal{F}(C)} \text{Cat}_{\ell_{I(F)}} 2^{-2\ell_{I(F)}} \right) = \left(\sum_{\ell_1, \ell_3, \dots, \ell_{2k-1} \geq 0} \prod_{F \in \mathcal{F}_o(C)} \text{Cat}_{\ell_{I(F)}} 2^{-2\ell_{I(F)}} \right) \cdot \left(\sum_{\ell_2, \ell_4, \dots, \ell_{2k-2} \geq 0} \prod_{F \in \mathcal{F}_e(C)} \text{Cat}_{\ell_{I(F)}} 2^{-2\ell_{I(F)}} \right).$$

This factorization yields sums over smaller index sets, which are easier to approximate numerically than the original sum.

Plugging Equation (7) into Equation (6), and using the above remark, gives the following formula for κ :

$$\kappa = \sum_{k=1}^{\infty} 2^{-4k+1} \sum_{C \in \mathcal{M}^{(1),k}} \left(\sum_{\ell_1, \ell_3, \dots, \ell_{2k-1} \geq 0} \prod_{F \in \mathcal{F}_o(C)} \text{Cat}_{\ell_{I(F)}} 2^{-2\ell_{I(F)}} \right) \cdot \left(\sum_{\ell_2, \ell_4, \dots, \ell_{2k-2} \geq 0} \prod_{F \in \mathcal{F}_e(C)} \text{Cat}_{\ell_{I(F)}} 2^{-2\ell_{I(F)}} \right).$$

Replacing infinite sums by some truncations allows to find lower bounds on κ . We have implemented this formula in Sage [16] (the code is available upon request) and found that $\kappa \geq 0.207$.

4.2 Upper bounds

In order to obtain upper bounds on κ , remark first that we can rewrite its expression in terms of the following event “the point 0 is the leftmost point of the connected component $C_0(\mathbf{M}_\infty)$ in the infinite noodle”. We call this event L_0 .

Lemma 12. We have

$$\kappa := \mathbb{E} \left[\frac{2}{|C_0(\mathbf{M}_\infty)|} \right] = 2 \mathbb{P}(L_0).$$

Proof. From Equation (8), we know that, conditionally on the size $|C_0(\mathbf{M}_\infty)| \in \mathbb{N} \cup \{\infty\}$ of the connected component of 0, the probability that 0 is the leftmost point of the component is exactly $1/|C_0(\mathbf{M}_\infty)|$ (the argument is given for $|C_0(\mathbf{M}_\infty)| < +\infty$ but is easily adapted to the infinite case to show that infinite components, if they exist, do not have leftmost points a.s.). This implies the lemma. ■

In order to see whether 0 is the leftmost point in its component or not, we discover the component step by step. More precisely, for any $k \geq 0$, define the event E_k : 0 is not the leftmost point of its connected component restricted to $(-\infty, k]$. In other words, one of the paths starting from 0 visits $(-\infty, -1]$ before visiting $[[k + 1, +\infty)$. Observe that the event E_k only depends on the value of $(\mathbf{w}_\infty^a, \mathbf{w}_\infty^b)$ on $[[0, k]$. Clearly, denoting \bar{L}_0 the complement of the event L_0 , we have $\bar{L}_0 = \bigcup_{k \geq 0} E_k$. Assuming \bar{L}_0 , one can thus define

$$K := \inf\{k \geq 0, E_k\}.$$

In particular, the event E_0 holds if and only if either $\mathbf{w}_\infty^a(0)$ or $\mathbf{w}_\infty^b(0)$ is R (which happens with probability $3/4$). Suppose now that $K \geq 1$. Then we define the *partial shape* P_0 of the component of 0 as follows: let $E \subset \mathbb{Z}_+$ be the connected component of 0 in the restriction $\mathbf{M}_\infty/[[0; K]$. There exists a unique bijection $g : E \rightarrow [[0, |E| - 1]$. The partial shape is the partial meandric system on $[[0, |E| - 1]$ obtained from the pair $(\mathbf{w}^a, \mathbf{w}^b)$ on $\{L, R\}^{|E|}$ such that, for all $0 \leq i \leq |E| - 1$, we set $\mathbf{w}^a(i) = \mathbf{w}_\infty^a(g^{-1}(i))$ and $\mathbf{w}^b(i) = \mathbf{w}_\infty^b(g^{-1}(i))$. In particular, P_0 is a partial meandric system with only one connected component. Moreover, since the event E_K holds, P_0 has at least one singleton either in the lower or upper matching (coming from an arc connecting $[[0; K]$ to $(-\infty, -1]$).

Lemma 13. Assume that \bar{L}_0 holds. Then, P_0 satisfies the following conditions.

- (i) Either $K = 0$ or the restriction of P_0 to $[[0, |E| - 2]$ does not have 0 and a singleton R in the same connected component.
- (ii) Each of the words \mathbf{w}^a and \mathbf{w}^b of P_0 has exactly one singleton, one of them being L and the other R .

(iii) Necessarily, P_0 has odd size.

Proof. All three items are straightforward if $K = 0$. Let us therefore assume in the proof that $K \geq 1$.

Item (i) follows by minimality of K . Indeed, if item (i) is not satisfied, then 0 is connected to $(-\infty, -1]$ in the restriction $\mathbf{M}_\infty/\llbracket 0; K-1 \rrbracket$, contradicting the minimality of K .

Let us first prove (ii). Since P_0 is connected and has at least one singleton, then necessarily the total number of singletons is exactly 2. Except if both are at position 0, it is clear that they have to be at different positions in P_0 , say s_1 and s_2 . Furthermore, necessarily one of them, say s_1 (we do **not** assume $s_1 < s_2$), has to take the value R by definition. Then, by item (i), $|E| - 1$ should be between s_1 and 0 when we follow P_0 . Therefore, it cannot be between s_2 and 0 (s_1 and s_2 are the extremities of P_0), so that s_2 is already connected to 0 in P_0 restricted to $\llbracket 0, |E| - 2 \rrbracket$. Using item (i), we conclude that the singleton in s_2 has value L .

We still need to prove that s_1 and s_2 are not singletons on the same side of the real line. Assume it is the case. Then P_0 visits first s_1 with the value R , then $|E| - 1$, then 0 and finally s_2 with the value L on the same side of the real line. This is impossible without crossing arches. Thus, (ii) holds.

Item (iii) follows directly, since matchings with exactly one singleton necessarily have odd size. ■

For any $k \geq 1$, we denote by \mathcal{P}_k the set of partial meanders on $\llbracket 0, 2k \rrbracket$ satisfying the three conditions of Lemma 13. The set \mathcal{P}_k is a subset of what are usually called open meanders of odd size. We can write the following proposition.

Proposition 14.

$$1 - \frac{\kappa}{2} = \mathbb{P}(\overline{L}_0) = \frac{3}{4} + \sum_{k \geq 1} \sum_{P \in \mathcal{P}_k} \mathbb{P}(P_0 = P). \quad (12)$$

The term $3/4$ corresponds to the probability that $K = 0$. We note that keeping only this term gives $1 - \frac{\kappa}{2} \geq \frac{3}{4}$, that is, $\kappa \leq \frac{1}{2}$, which is exactly the upper bound provided by Goulden *et al.* [8].

Similarly to $\mathbb{P}(S_0 = C)$ above, we can obtain a summation formula for $\mathbb{P}(P_0 = P)$. Let P be in \mathcal{P}_k . As for meanders, we denote $\mathcal{F}(P)$ its set of faces, that is, *bounded regions* delimited by the arcs and the real line. We also define two *open faces* as follows. Assume

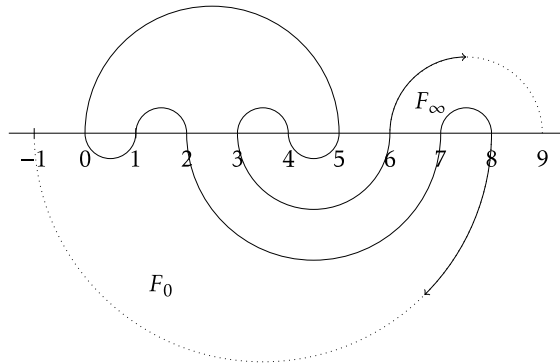

Fig. 6. A possible partial shape on $\llbracket 0, 8 \rrbracket$ and the two added virtual open faces F_0 and F_∞ .

(up to symmetry) that there exists $s_1, s_2 \leq 2k$ such that $w^a(s_1) = L$ and $w^b(s_2) = R$. We complete P with an arc in the upper half-plane from s_1 to $2k + 1$ and an arc in the lower half-plane from -1 to s_2 . This creates two new faces that we denote respectively F_∞ and F_0 . See Figure 6.

Before stating our formula, we recall a classical result of enumerative combinatorics (see, e.g., [15, Ex.6.19, p. 219]). For any $n \geq 0$, we denote by N_n the number of simple walks $S : \llbracket 0, n \rrbracket \rightarrow \mathbb{Z}$ such that $S_0 = 0$ and $S \geq 0$.

Lemma 15. For all $n \geq 1$, we have

$$N_n = \binom{n}{\lfloor n/2 \rfloor}.$$

This helps us get the following proposition.

Proposition 16. For any $k \geq 1$ and any element $P \in \mathcal{P}_k$, we have (keeping the notation of Lemma 10)

$$\mathbb{P}(P_0 = P) = 2^{-4k-2} \sum_{\ell_0, \dots, \ell_{2k-1} \geq 0} \left(\prod_{F \in \mathcal{F}} \text{Cat}_{\ell_I(F)} 2^{-2\ell(F)} \right) \times \binom{2\ell_{I(F_0)}}{\ell_{I(F_0)}} 2^{-2\ell_{I(F_0)}} \times \binom{2\ell_{I(F_\infty)}}{\ell_{I(F_\infty)}} 2^{-2\ell_{I(F_\infty)}},$$

where, by convenience, we have set $\ell_{-1} = \ell_{2k} = 0$.

Proof. We prove this lemma the same way as Lemma 10. Fix $k \geq 1$, and take P a partial meander in \mathcal{P}_k . We split the event $P_0 = P$, depending on the set of points E . As in the proof of Lemma 10, we can find integers $m_1, \dots, m_{2k-1} \geq 0$ such that $E = \{0, m_1 + 1, \dots, m_{2k-1} + 2k - 1\}$, all these integers being even. For all $i \leq 2k - 1$, set $m_i = 2\ell_i$.

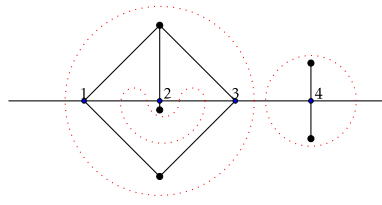

Fig. 7. An example of the bijection of [8]. Here, $n = 4$, the partition π (top) is $\{\{1, 2, 3\}, \{4\}\}$ and the partition ρ (bottom) is $\{\{1, 3\}, \{2\}, \{4\}\}$. The red dots represent the associated meander of size 4.

V is part of a partition π . A partition is non-crossing if there is no $i \neq j \in \{1, \dots, k\}$ and $a < b < c < d$ such that $a, c \in V_i$ and $b, d \in V_j$. We denote by $NC(n)$ the set of non-crossing partitions of n .

The set $NC(n)$ is endowed with a partial order as follows: for any $\pi, \rho \in NC(n)$, we say that $\pi \leq \rho$ if, for any $V \in \pi$, there exists $W \in \rho$ such that $V \subseteq W$. In other words, ρ can be obtained from π by merging blocks. In particular, with this order, $(NC(n), \leq)$ admits a minimum element 0_n (the partition of $\{1, \dots, n\}$ into n blocks of size 1), and a maximum element 1_n (the partition into a unique block of size n).

For $\rho, \pi \in NC(n)$, we say that ρ covers π if $\pi < \rho$ and there is no θ such that $\pi < \theta < \rho$. The Hasse diagram of $NC(n)$ is the (undirected) graph whose vertices are the elements of $NC(n)$, and where two vertices π, ρ are connected if π covers ρ or ρ covers π .

In [8], the authors construct a bijection from $NC(n)^2$ to the set of meandric systems of size n , as shown in Figure 7. Roughly speaking, they represent a partition π by drawing the points $\{1, \dots, n\}$ on a line, and then connecting all points in a given block of π to the same external point above the axis, in a non-crossing way. They also do the same for a partition ρ below the axis, which gives a graph $\Gamma(\pi, \rho)$. Finally, drawing one point immediately before and one immediately after each of the integers $\{1, \dots, n\}$, they join these new $2n$ points by following the edges of the graph $\Gamma(\pi, \rho)$. This gives a meandric system $M(\pi, \rho)$ on $2n$ points.

This construction is a bijection (see [8, Section 3]), with the additional property that

$$d_{\mathcal{M}_n}(\pi, \rho) = n - cc(M(\pi, \rho)).$$

References

[1] Benjamini, I. and O. Schramm. "Recurrence of distributional limits of finite planar graphs." *Electron. J. Probab.* 6, no. 23 (2001): 13 (electronic).

- [2] Borga, J. "Asymptotic normality of consecutive patterns in permutations encoded by generating trees with one-dimensional labels." *Random Structures Algorithms* 59 (2021): 339–75.
- [3] Curien, N., G. Kozma, V. Sidoravicius, and L. Tournier. "Uniqueness of the infinite noodle." *Ann. Inst. Henri Poincaré D* 6, no. 2 (2019): 221–38.
- [4] Delecroix, V., É. Goujard, P. Zograf, and A. Zorich. "Enumeration of meanders and Masur–Veech volumes." *Forum Math. Pi* 8, no. e4 (2020): 80.
- [5] Di Francesco, P., O. Golinelli, and E. Guitter. "Meander, folding, and arch statistics." *Math. Comput. Modelling* 26, no. 8–10 (1997): 97–147.
- [6] Di Francesco, P., O. Golinelli, and E. Guitter. "Meanders: exact asymptotics." *Nuclear Phys. B Proc. Suppl.* 570, no. 3 (2000): 699–712.
- [7] Fukuda, M. and I. Nechita. "Enumerating meandric systems with large number of loops." *Ann. Inst. Henri Poincaré D* 6, no. 4 (2019): 607–40.
- [8] Goulden, I. P., A. Nica, and D. Puder. "Asymptotics for a class of meandric systems, via the Hasse diagram of $\text{NC}(n)$." *Int. Math. Res. Not. IMRN* 2020, no. 4 (2020): 983–1034.
- [9] Janson, S. "Asymptotic normality of fringe subtrees and additive functionals in conditioned Galton–Watson trees." *Random Structures Algorithms* 48, no. 1 (2016): 57–101.
- [10] Janson, S. "Tree limits and limits of random trees." *Combin. Probab. Comput.* 30 (2021): 849–93.
- [11] Kallenberg, O. *Random Measures, Theory and Applications*, vol. 77. Probability Theory and Stochastic Modelling. Cham: Springer, 2017.
- [12] Kargin, V. "Cycles in random meander systems." *J. Statist. Phys.* 181, no. 6 (2020): 2322–45.
- [13] Mirzakhani, M. "Growth of the number of simple closed geodesics on hyperbolic surfaces." *Ann. of Math. (2)* 168, no. 1 (2008): 97–125.
- [14] Nica, A. "Free probability aspect of irreducible meandric systems, and some related observations about meanders." *Infin. Dimens. Anal. Quantum Probab. Relat. Top.* 19, no. 2 (2016): 1650011, 22.
- [15] Stanley, R. P. *Enumerative Combinatorics: Vol. 2*, vol. 62. Cambridge Studies in Advanced Mathematics. Cambridge: Cambridge University Press, 1999. With a foreword by Gian-Carlo Rota and appendix 1 by Sergey Fomin.
- [16] The SageMath Developers "SageMath Mathematics Software (Version 9.2)." (2020). <http://www.sagemath.org>.
- [17] Zvonkine, A. "Meanders: a personal perspective. In memoriam of Pierre Rosenstiehl." (2021): available online.