



**HAL**  
open science

## On-chip memories at the edge

Kevin J. M. Martin

► **To cite this version:**

| Kevin J. M. Martin. On-chip memories at the edge. Doctoral. France. 2022. hal-03710634

**HAL Id: hal-03710634**

**<https://hal.science/hal-03710634v1>**

Submitted on 30 Jun 2022

**HAL** is a multi-disciplinary open access archive for the deposit and dissemination of scientific research documents, whether they are published or not. The documents may come from teaching and research institutions in France or abroad, or from public or private research centers.

L'archive ouverte pluridisciplinaire **HAL**, est destinée au dépôt et à la diffusion de documents scientifiques de niveau recherche, publiés ou non, émanant des établissements d'enseignement et de recherche français ou étrangers, des laboratoires publics ou privés.

# On-chip memories at the edge

The edge of memories

**Kevin J. M. Martin**  
Maître de conférences

Univ. Bretagne-Sud  
UMR CNRS 6285, Lab-STICC  
Lorient, France

14/06/2022, AMLE summer school, Lorient



# *It's the Memory, Stupid!*

Richard Sites, lead designer of the DEC Alpha, 1996

*I expect that over the coming decade memory subsystems design will be the **only** important design issue for microprocessors.*

Most of his colleagues designing next-generation Alpha architectures at Digital Equipment Corp. ignored his advice and instead remained focused on building ever faster microprocessors, rather than shifting their focus to the building of ever faster *systems* [8].

N.B.: Digital Equipment Corp. no longer exists

# What memory is needed for?

- storing data
- storing instructions
- saving temporary values
- synchronizing processes/threads

# Connection of the memory to the processor

## Von Neumann vs Harvard Architecture

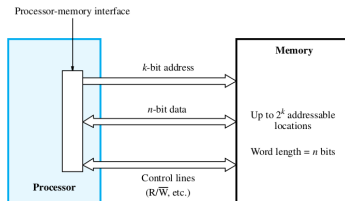

## Von Neumann Architecture

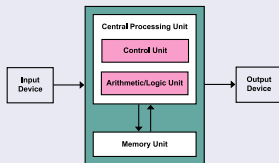

- 1945
- common bus for instruction and data

## Harvard Architecture

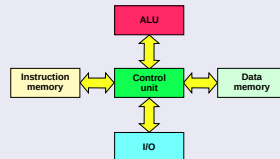

- 1944
- separate bus for instruction and data

# The ideal memory is

- fast
- large
- inexpensive

## Impossible to meet these three requirements

- physical properties of memories: area, delay, energy consumption
- economical issues
- $\nearrow$  speed +  $\nearrow$  size =  $\nearrow$  cost
- $\nearrow$  size  $\Rightarrow$   $\searrow$  speed

## Different solutions and structures exist

- different technologies
- different organisations
- for different needs (permanent store, operating store, fast store)

# Memory hierarchy

The processor designer would choose

speed

The user would choose

size

The manufacturer would choose

cost

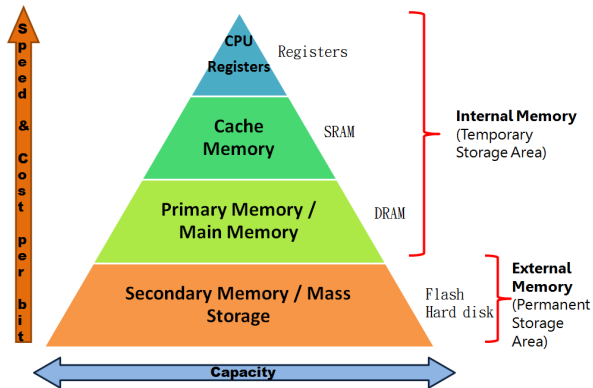

Memory hierarchy as an enabler

Source: not me

# Exynos M3 Core Layout

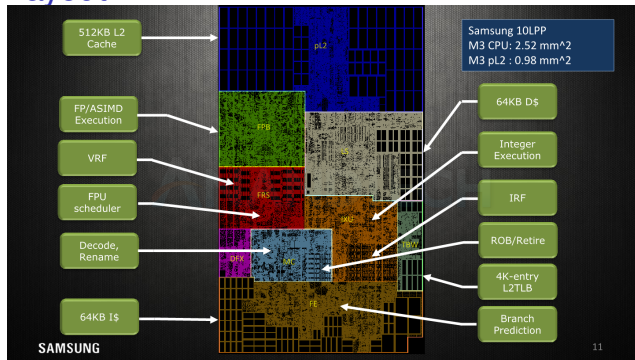

Source: [www.anandtech.com](http://www.anandtech.com)

- pL2: Private L2 cache, 512KB
- FPB: Floating point data path
- FRS: Floating point schedulers
- MC: Mid-core, the decoders and rename units.
- DFX: This is for debug/test logic
- LS: Load/store unit along with the 64KB of L1 data cache
- IXU: Integer execution unit; execution units, schedulers, integer physical register file memories.
- TBW: Transparent buffer writes, includes the TLB structures.
- FE: The front-end including branch predictors, fetch units and the 64KB L1 instruction cache memories.



## Insight on current challenges

- more than 80% of the chip area is dedicated to caches, memories, memory controllers, interconnects and so on, whose sole purpose is to buffer data or control the buffering of data [1]
- ⇒ workarounds which are making systems ever more complex
- more than 62% of the entire measured system energy is spent on moving data between memory and the computation units [1]

# Content

## This lecture will cover

- Basic memory organisations
- Overview on memory technologies
- Memory system
  - Caches
  - Virtual memory
- The future
  - Emerging memory technologies
  - Near-memory computing, Computing in Memory

## This lecture will NOT cover

- Massive storage (Hard Disk drives, magnetic or optical drives, etc.)
- Exhaustive DRAM features (timing, controller, protocol, system)
- I/O Topics
- Detailed cache coherence

# Flip-Flops and Latches

## Definition

- latch: A memory element in which the output is equal to the value of the stored state inside the element and the state is changed whenever the appropriate inputs change and the **clock is asserted**
- D latch: A latch with **one data input** (called  $D$ ) that stores the value of that input signal in the internal memory

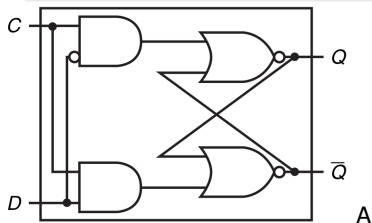

D latch implemented with NOR gates

Source: [11]

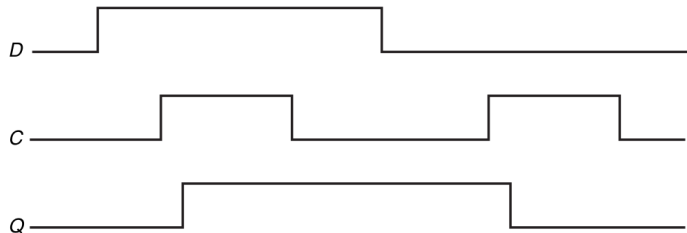

Operation of a D latch, assuming the output is initially deasserted

# D flip-flop

## Definition

- flip-flop: A memory element for which the output is equal to the value of the stored state inside the element and for which the internal state is changed **only on a clock edge**
- D flip-flop: A flip-flop with **one data input** (called  $D$ ) that stores the value of that input signal in the internal memory when the **clock edge occurs**

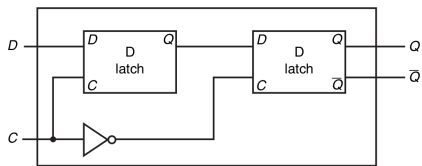

A D flip-flop with a falling-edge trigger

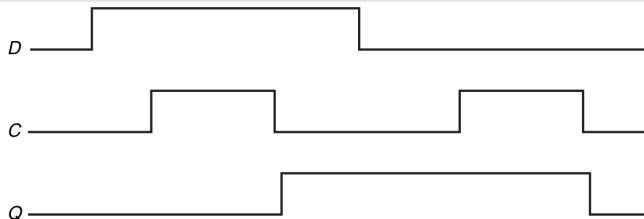

Operation of a D flip-flop with a falling-edge trigger, assuming the output is initially deasserted

Source: [11]

# D flip-flop

## Timing

The D input is sampled on the clock edge, it must be valid for a period of time immediately before and immediately after the clock edge

## Definition

- Setup time: the minimum time that the input to a memory device must be valid before the clock edge
- Hold time: the minimum time during which the input must be valid after the clock edge

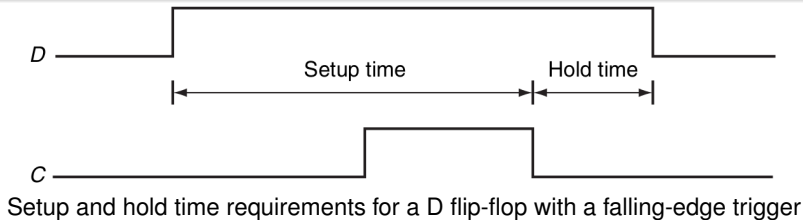

Source: [11]

# Registers

## Definition

- Register: an array of D flip-flops that can hold a multibit datum, such as a byte or word

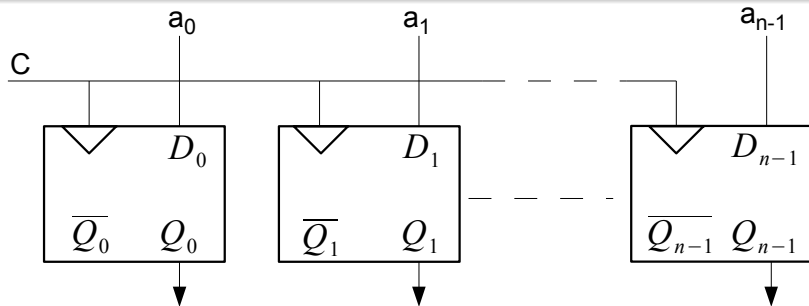

# Registers and register files

## Register File

- Set of registers
- Specify the register number to be accessed
- One decoder per read or write port
- **Central structure of the datapath of a processor**

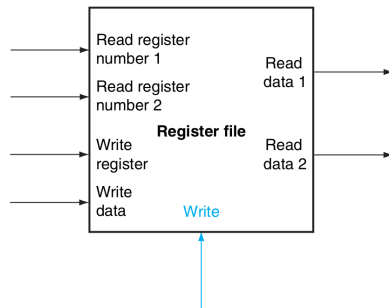

A register file with two read ports and one write port has five inputs and two outputs

# Registers and register files

## Reading a value

### Read operation

- Input: register number
- Output: data contained in that register

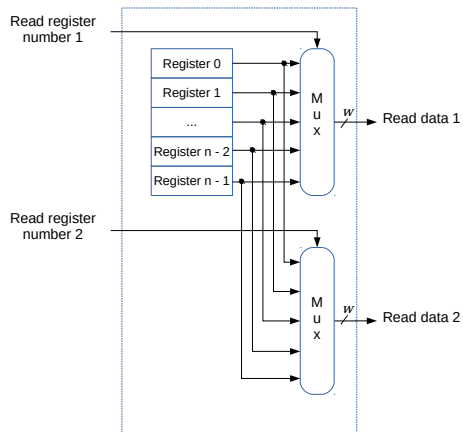

Implementation of two read ports for a register file with  $n$  registers with a pair of  $n$ -to-1 multiplexers, each  $w$  bits wide



# Registers and register files

## Writing a value

### Write operation

- 3 inputs:
  - 1 register number
  - 2 data value
  - 3 clock (write signal)

### Timing constraints

Setup and hold-time constraints to ensure that the correct data is written into the register file

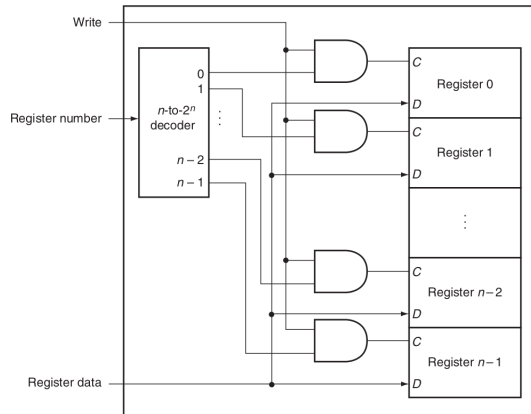

The write port for a register file is implemented with a decoder that is used with the write signal to generate the  $C$  input to the registers

# Registers and register files

## Register file parameters

- Size (number of registers)
- Number of ports
- Width? (usually set by data width)

## Size

- Too small: register *spilling*
- Too large: static energy, extra chip area

## The tricky thing

Reading the value currently being written (in the same clock cycle)

## Number of ports

- nonlinear cost function of the number of ports
  - (partitioned register files for some VLIW processors)
- 2 read ports + 1 write port: good trade-off

# Registers and register files

Unsuited for big memories

## ? Bigger memories

Small memories are built using registers and register files:

- configuration registers
- pipeline registers
- processor register file (32x32 = 128 B)

Bigger memories are built upon another organisation

# Measuring memory size

## Power of 2 vs power of 10

Unit multiples of the octet (byte) may be formed with SI prefixes and binary prefixes (power of 2 prefixes) as standardized in 1998 [2]

- 1 Byte = 8 bits
- 1 kilobyte (kB) =  $10^3$  bytes  
= 1 000 bytes
- 1 kibibyte (KiB) =  $2^{10}$  bytes  
= 1 024 bytes
- ...

## Comparison of decimal and binary units

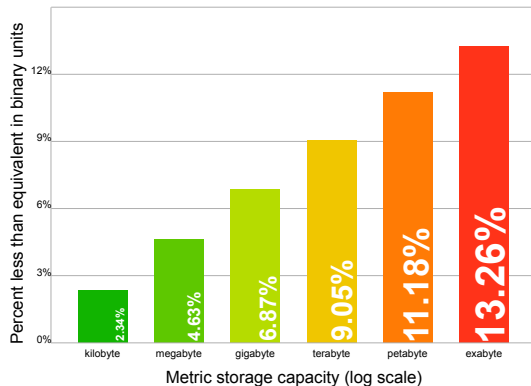

By Ryoushi19 - Own work, Public Domain,

<https://commons.wikimedia.org/w/index.php?curid=6808262>

# Internal Organisation of Memory Chips

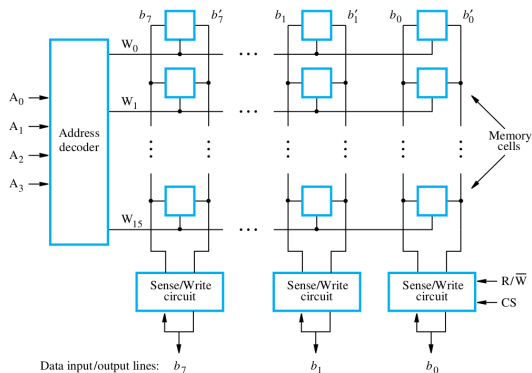

Memory cells organized in the form of an array

## Definition

- height: the number of addressable locations
- width: the number of bits per unit

# Internal Organisation of Memory Chips

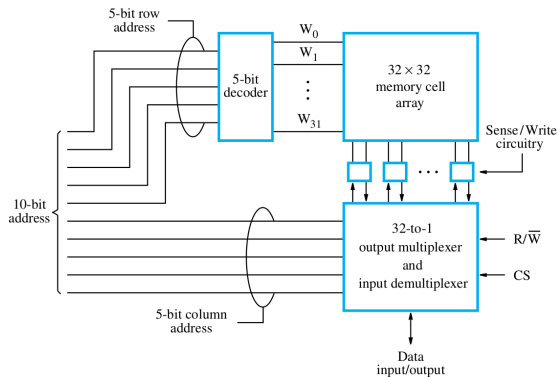

Organization of a 1K x 1 memory chip

## Impact on the number of wires

Example with storing 1024 bits

	1K x 1	128 x 8	32 x 32
CS	1	1	1
$R/\overline{W}$	1	1	1
VCC	1	1	1
GND	1	1	1
Data	1	8	32
Address	10	7	5
$\Sigma$	15	19	41



### Narrow configurations

Fastest and newest memories use narrow configurations (x1 or x4)

# Internal Organisation of Memory Chips

The output multiplexor

## Large memory

A 64K-to-1 multiplexor that would be needed for a 64K x 1 memory is totally impractical!

## Tri-State Buffers

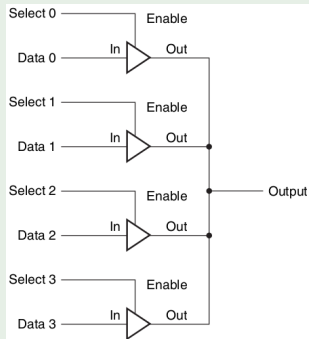

Four three-state buffers are used to form a multiplexor

Two inputs:

- data signal
- Output enable

One output with three states:

- asserted
- deasserted
- high impedance

# Internal Organisation of Memory Chips

The decoder

## Large memory

A 4M x 8 memory, we would need a 22-to-4M decoder and 4M word lines!

## Rectangular arrays and two-step decoding process

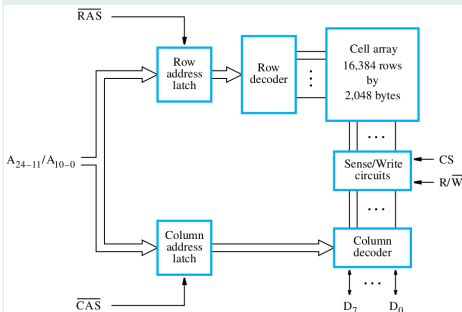

Internal organization of a 32M x 8 memory chip

- 16K x 16K array
- 16,384 cells in each row divided into 2,048 groups of 8  $\Rightarrow$  2,048 bytes of data
- 14 address bits to select a row, 11 address bits needed to select a column
- Multiplexing the wires
  - RAS: Row Access Strobe
  - CAS: Column Access Strobe



# Internal Organisation of Memory Chips

The memory cell can be:

- SRAMs (static random access memories)
- DRAMs (dynamic random access memories)

# SRAM

## Definition

Static Memory: *Memory capable of retaining its state as long as power is applied* [5]

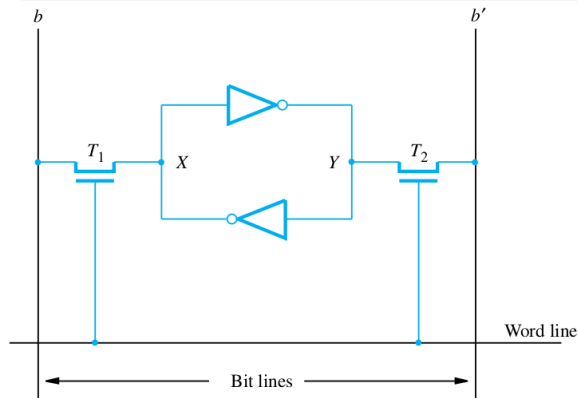

Source: [5]

## SRAM: Static Random Access Memory

- Two inverters cross-connected to form a latch
- Two bit lines ( $T_1$  and  $T_2$ )
- $b$  and  $b'$  are always complements

# SRAM

## Reading and writing an SRAM cell

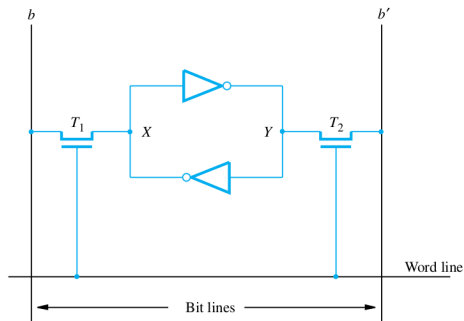

### Read Operation

- 1 The word line is activated to close switches  $T_1$  and  $T_2$
- 2 The Sense/Write circuit at the end of the two bit lines monitors their state

### Write Operation

- 1 The word line is activated to close switches  $T_1$  and  $T_2$
- 2 The Sense/Write circuit drives bit lines  $b$  and  $b'$ , instead of sensing their state

# Overview of memory technologies

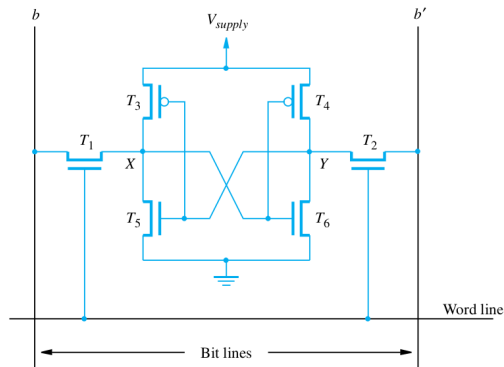

CMOS implementation of 6T SRAM memory cell [5]

## CMOS SRAM cell

- Transistor pairs ( $T_3$ ,  $T_5$ ) and ( $T_4$ ,  $T_6$ ) form the inverters in the latch
- Continuous power is needed for the cell to retain its state
- Content lost when power down
- Back in stable state when power on (but maybe not the same state)



## ***Volatile memory***

SRAMs are *volatile memory* because they lose their content when power is shut down

# Overview of memory technologies

## SRAM CMOS physical design

Cross Section of Double Well CMOS LSI

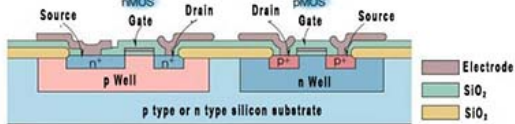

Source: [http://www.shmj.or.jp/innovation50/english/detail\\_D05E.htm](http://www.shmj.or.jp/innovation50/english/detail_D05E.htm)

## Layout of 6T SRAM Cell

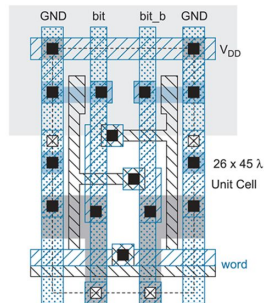

Only poly and diff layers are shown.

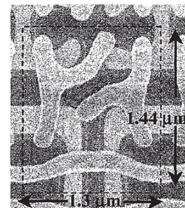

Source: Digital Design: Principles and Practices, Published by Jonas Wilkerson

# SRAM

## Pros and cons



### SRAM strong points

- Same fabrication process as logic circuit
  - Good integration on processor die
  - Ideal candidate for cache implementation
- Low power consumption
- Fast (+fixed access time)



### SRAM weak points

- Expensive
- Low density

# DRAM

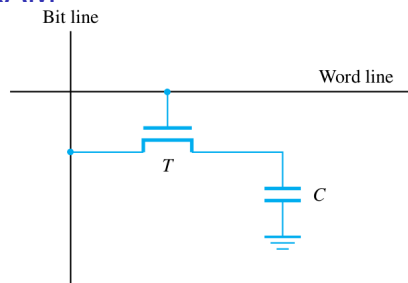

Source: [5]

## DRAM: *Dynamic* Random Access Memory

- A capacitor C
- A transistor T

### Why is it called *Dynamic*?

The capacitor can retain its state for tens of milliseconds only.  
Need to *refresh* periodically.



### ***Volatile memory***

DRAMs are *volatile memory* because they lose their content when power is shut down

# Overview of memory technologies

## DRAM physical design

DRAM(3xnm) Capacitor



Source: [7]



### Did you know?

DRAM's capacity has been one of the more consistent incarnations of Moore's law [7]

- scaled in capacity by a factor of over 16 million
- 1 kbits on a die in 1970 to 16 Gbits in 2020



# DRAM

## SDRAM

### SDRAM: *Synchronous* DRAM

Synchronisation with a clock signal

- built-in refresh circuitry (hides the dynamic feature of DRAM to the user)
- *burst* mode: starting address + burst length

### Definition

*Page*: a large block of data

### *Fast Page Mode*

Transfer a *page* of data: all bytes of the selected row in sequential order

- no need to reselect the row
- successive CAS signals

# DRAM

## DDR: Double-Data-Rate SDRAM

- Transfer data on both rising and falling edge of the clock
- Open standard

## Rambus Memory

- Differential-signaling technique to transfer data to and from the memory chips
- Proprietary scheme that must be licensed

# DRAM

## Pros and cons



### DRAM strong points

- High density
- Low cost per bit



### DRAM weak points

- Must be refreshed periodically
- Hard integration of DRAM with logic technology
- Slower than SRAM

# DRAM

## Memory controller

In charge of:

- 2 steps access: row + column, RAS + CAS signals
- chip select: when multiple memory modules
- refresh: periodic read cycles of asynchronous DRAM

## Refresh overhead

- When internal refresh operation occurs, the memory **cannot respond**
- Typically few percent of the total time available for accessing the memory
- Still ongoing research activities
  - Goal: hide completely the refresh

# Memory technology comparison

Technology	Bytes per Access (typ.)	Latency per Access	Cost per Megabyte <sup>a</sup>	Energy per Access
On-chip Cache	10	100 of picoseconds	\$1–100	1 nJ
Off-chip Cache	100	Nanoseconds	\$1–10	10–100 nJ
DRAM	1000 (internally fetched)	10–100 nanoseconds	\$0.1	1–100 nJ (per device)
Disk	1000	Milliseconds	\$0.001	100–1000 mJ

Source: [8]

## Choice of technology

- SRAM: small but very fast memory
- DRAM (DDR SDRAM): main memory

# Memory chips

## Static memory chip

### Alliance Memory SRAM, AS6C1008-55STIN- 1048576bit



RS Stock No.: 170-0890 | Mfr. Part No.: AS6C1008-55STIN | Brand: Alliance Memory



Available to back order for despatch  
23/07/2019

Price Each (In a Tray of 234)

**£1.314**  
(exc. VAT)

**£1.577**  
(inc. VAT)

Units	Per unit	Per Tray*
234 - 468	£1.314	£307.476
702 - 936	£1.297	£303.498
1170 - 2106	£1.28	£299.52

## Dynamic memory chip

SEMICONDUCTEURS

TROISIEME GÉNÉRATION DE DRAM DDR4 8 GBITS  
CHEZ SAMSUNG

Édition pub. Philippe Bourdeau - 11/02/2014 23 Mars 2014 12:34

Taille de police: [ ] | Imprimer | E-mail

SAMSUNG

DDR4

1z nm



# Overview of memory technologies

Emerging technologies

*Patience, grasshoper...*

This is discussed later

# ROM

Read Only Memory



## ***Volatile memory***

| SRAMs and DRAMs are *volatile memory*



## ***Non Volatile memory***

| Need to store software and data and not loose information when power is shut down





# PROM

Programmable Read Only Memory

## PROM

“Programmable” through a fuse

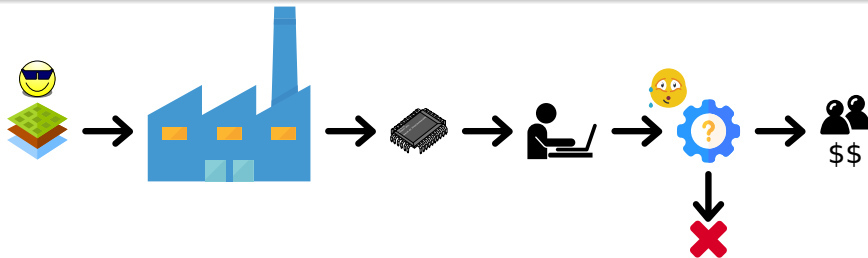

# EPROM

Erasable Programmable Read Only Memory

## EPROM

“Erasable and Programmable” through a *special transistor*

Expose the chip to ultraviolet light to erase

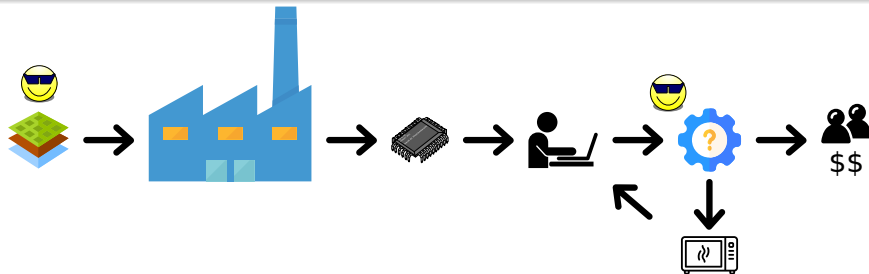

# EEPROM

Electrically Erasable Programmable Read Only Memory

## EEPROM

different voltages are needed for erasing, writing, and reading the stored data  $\Rightarrow$  circuit complexity

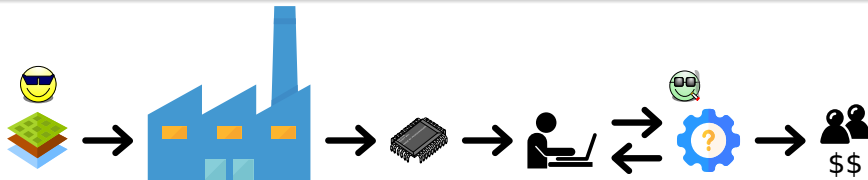

# Flash Memory

## Flash Memory

- read the contents of a single cell
- write an entire block of cells

## Flash Cards



## Flash drives (SSD)

2 To, SATA 3 (6 Gb/s), 2,5"



# Types of memories

The sore point

volatile vs non-volatile  
RAM vs ROM

**RAM: Random Access Memory**

RAM = volatile?

**ROM: Read Only Memory**

ROM = non-volatile?

**What about writing data in a non-volatile memory?**

e.g. Hard disk drive, USB key, ...

# Memory classification

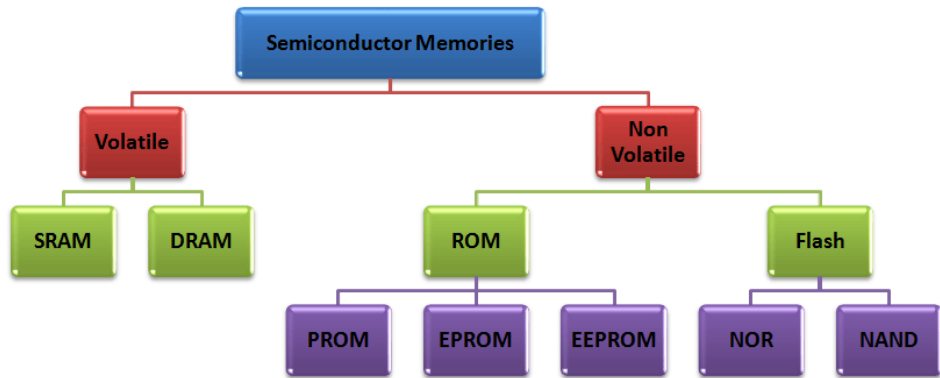

Source: [12]

# Overview of computer memory organisation

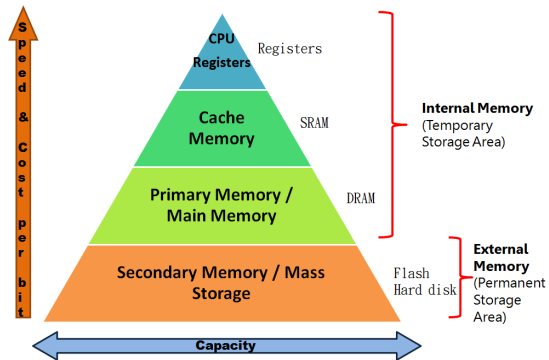

## From the I/O device to the processor

The data need to move across the levels

- From the I/O to the main memory
- From the main memory to the cache
- From the cache to CPU registers

## Managing data movement

Offload the processor from weighty data movement tasks



# The memory system

## Direct Memory Access

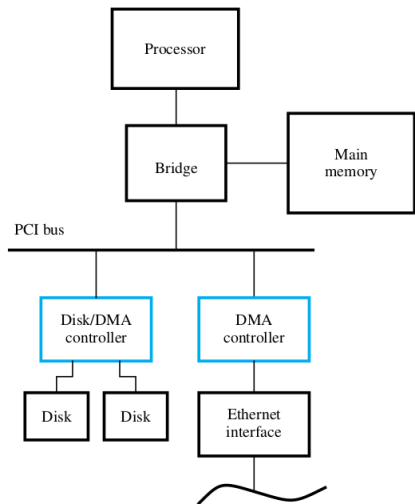

## DMA

A special control unit to manage the transfer, without continuous intervention by the processor

# The memory system

## Direct Memory Access

### Under supervision (usually operating system)

- Processor provides:
  - starting address
  - the number of words in the block
  - the direction of the transfer
- DMA raises an interrupt when finished

# Caches

## The illusion of a large memory

accessible as fast as a small memory [11]



### Idea

A processor does not need to access all of the program codes and data at once. Let's keep near the useful parts.

## Principle of locality

- Temporal locality (locality in time): if an item is referenced, it will tend to be referenced again soon.
- Spatial locality (locality in space): if an item is referenced, items whose addresses are close by will tend to be referenced soon.

## Definition

- *block* or *line*: the minimum unit of information that can be either present or not present in a cache.
- *hit*: the data requested is present in the cache
- *miss*: the data requested is NOT present in the cache
- *hit rate* or *hit ratio*: the fraction of memory accesses found in the upper level
- *miss rate* ( $1 - \text{hit rate}$ ): the fraction of memory accesses NOT found in the upper level



## **Message to programmers**

No, memory is NOT a flat, random access device

You need to understand memory hierarchy to get good performance

# The big picture

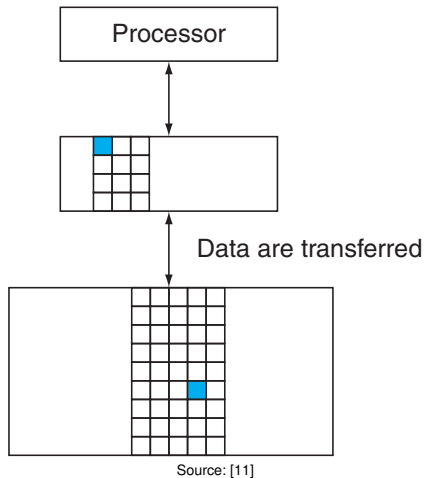

## Memory hierarchy

- upper and lower level
- transfer entire block between levels

# Caches

## Direct-map cache

### Direct-mapped cache

A cache structure in which each memory location is mapped to exactly one location in the cache

$$\text{Position} = (\text{Block number}) \bmod (\text{Number of blocks in the cache})$$

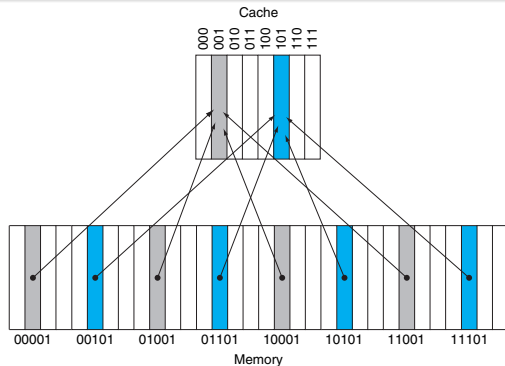

Source: [11] A direct-mapped cache with eight entries showing the addresses of memory words between 0 and 31 that map to the same cache locations



Simple to implement



High miss rate

# Caches

## Fully Associative Cache

### Fully Associative Cache

A cache structure in which a block can be placed in any location in the cache



I Low miss rate



I Hardware cost



# Caches

n-way set-associative cache

## set-associative cache

- A cache that has a fixed number of locations (at least two) where each block can be placed
- Each block in the memory maps to a unique set in the cache
- A block can be placed in *any* element of that set
- n is the number of places in the set



| Good trade-off between direct-map and fully associative



| Finding the good trade-off!

# Caches

## Replacement Algorithms

### Which block to replace?

- Intuitively, replace the one that has gone the longest time without being referenced
  - *Least Recently Used* (LRU)
  - keep track of all references by means of counters
- The simplest algorithm: randomly choose the block to be replaced
  - quite effective in practice
- Many others:
  - FIFO (*First In First Out*)
  - LFU (*Least Frequently Used*)
  - pseudo-LRU

# Caches

## Tags

### Definition

- *Tag*: A field in a table used for a memory hierarchy that contains the address information required to identify whether the associated block in the hierarchy corresponds to a requested word
- *Valid bit*: A field in the tables of a memory hierarchy that indicates that the associated block in the hierarchy contains valid data

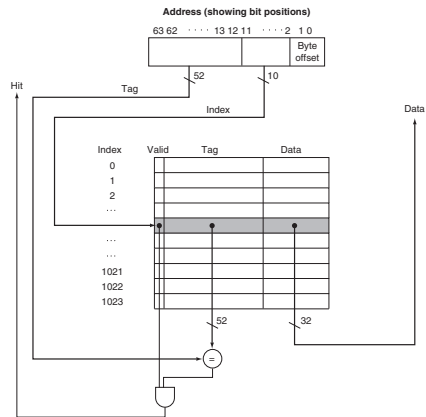

The lower portion of the address is used to select a cache entry consisting of a data word and a tag [11]

# Caches

## Tags

### Size of tags versus associativity

Increasing associativity requires more comparators and more tag bits

### Cache of 4096 blocks, four-word block size, 64-bit address

16 bytes per block  $\Rightarrow$  64-4=60 bits for index and tag

- Direct-map cache
  - number of sets = number of blocks  $\Rightarrow$  12 bits of index ( $\log_2(4096) = 12$ )
  - $(60 - 12) \times 4096 = 192$  Ki tag bits
- Two way associative cache
  - number of sets = 2048  $\Rightarrow$  11 bits of index ( $\log_2(2048) = 11$ )
  - $(60 - 11) \times 2 \times 2048 = 196$  Ki tag bits
- Fully associative cache
  - number of sets = 1  $\Rightarrow$  0 bits of index ( $\log_2(1) = 0$ )
  - $60 \times 1 \times 4096 = 240$  Ki tag bits

### Size of tags versus associativity

Increasing associativity requires more comparators and more tag bits



#### **Size given by the manufacturer**

| The size of the cache given by the manufacturer does not include the size of tags + valid bit.

### Content Addressable Memory

A circuit that combines comparison and storage in a single device

- RAM: supply address, return data
- CAM: supply data, return index

# Caches

## Handling writes

### Consistency

When the cache and the main memory have different values, they are *inconsistent*

### Write-through

- Always update cache AND next lower level of the hierarchy
- Processor is *stall* during writing to main memory ( $\approx 100$  cycles)
- Use of *write buffer* to free the processor

### Write-back

- Update the cache only
- Update next lower level when the block is replaced
- Improve performance but more complex to implement

# Caches

## Split cache

### Two independent caches

- instruction cache
- data cache

operating in parallel

### ? **Harvard computer style**

| Can the split cache be considered as an implementation of Harvard architecture?



# Caches

## Multilevel cache

### Close the gap between primary cache and DRAM

- Primary cache: focus on minimizing hit time
  - Smaller block size, reduce miss penalty
- Secondary cache: focus on minimizing the miss rate
  - Larger total size, higher associativity

# Caches

Cannot reach 0% miss

## The three Cs: behavior of memory hierarchies

- *Compulsory miss (or cold-start miss)*: A cache miss caused by the first access to a block that has never been in the cache
- *Capacity miss*: A cache miss that occurs because the cache, even with full associativity, cannot contain all the blocks needed to satisfy the request
- *Conflict miss*: A cache miss that occurs in a set-associative or direct mapped cache when multiple blocks compete for the same set and that are eliminated in a fully associative cache of the same size

# Virtual memory

## Two historical motivations

- 1 efficient and safe sharing of memory among several programs
- 2 remove the programming burden of a small limited amount of main memory

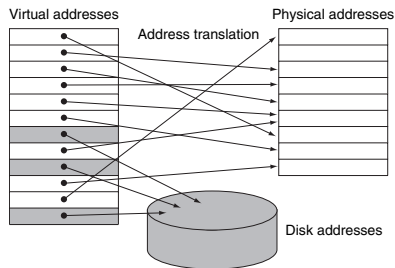

In virtual memory, blocks of memory (called pages) are mapped from one set of addresses (called virtual addresses) to another set (called physical addresses) [11]

## Size of virtual address space

- A 32-bit processor can address up to  $2^{32} = 4Gi$  elements
- A 64-bit processor can address up to  $2^{64} = 16Ei$  (exbi) elements ( $> 10^{18}$ )

# Virtual memory

## Definition

- Virtual memory: A technique that uses main memory as a “cache” for secondary storage
- Physical address: An address in main memory
- Protection: A set of mechanisms for ensuring that multiple processes sharing the processor, memory, or I/O devices cannot interfere, intentionally or unintentionally, with one another by reading or writing each other's data. These mechanisms also isolate the operating system from a user process
- Page fault: An event that occurs when an accessed page is not present in main memory
- Virtual address: An address that corresponds to a location in virtual space and is translated by address mapping to a physical address when memory is accessed
- Address translation (or address mapping): The process by which a virtual address is mapped to an address used to access memory

# Virtual memory

## Mapping

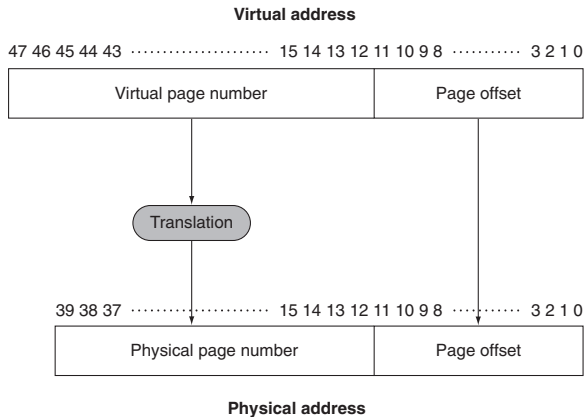

Mapping from a virtual to a physical address. The page size is  $2^{12} = 4$  KiB. The number of physical pages allowed in memory is  $2^{28}$ , since the physical page number has 28 bits in it. Thus, main memory can have at most 1 TiB, while the virtual address space is 256 TiB [11]

## High cost of a page fault

Enormous miss penalty: 1 page fault = millions of clock cycles

Key decisions:

- Page should be large enough to amortize the high access time (4 KiB to 64 KiB)
- Allow fully associative placement
- Software page handling (faults and placement)
- Write-back (write-through takes too long)

# Virtual memory

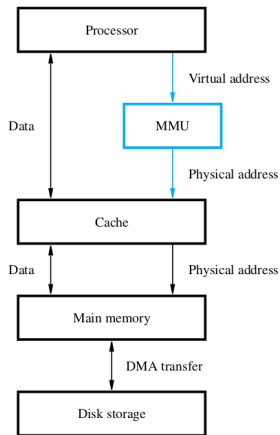

Virtual memory organization [5]

## *Memory Management Unit (MMU)*

- keeps track of which parts of the virtual address space are in the physical memory
- translates the virtual address into the corresponding physical address

# Virtual memory

## Placing a page and finding it again

### Definition

*Page Table:* the table containing the virtual to physical address translations

- stored in memory, indexed by the virtual page number
- each entry in the table contains the physical page number for that virtual page

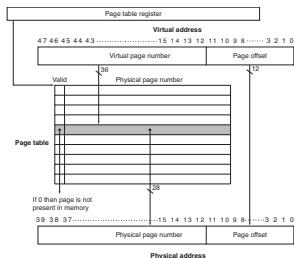

- Each program has its own page table
- *page table register*: the start of the page table
- *valid bit*: page present or not in memory

The page table is indexed with the virtual page number to obtain the corresponding portion of the physical address [11]



# Virtual memory

## Page faults

- Page fault when the valid bit for a virtual page is off
- Software exception
- Operating system gets control
  - find the page
  - decide where to place it in main memory
  - *Least Recently Used* replacement scheme



### **The operating system is a process**

The tables controlling the memory are in the memory.

We need to access to the memory to access to the memory!

# Virtual memory

Making the translation fast

## Definition

TLB: translation-lookaside buffer. A cache that keeps track of recently used address mappings to try to avoid an access to the page table

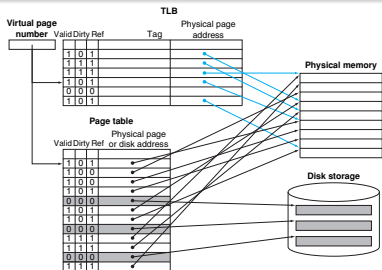

The TLB acts as a cache of the page table for the entries that map to physical pages only [11]

# Virtual memory

## Making the translation fast

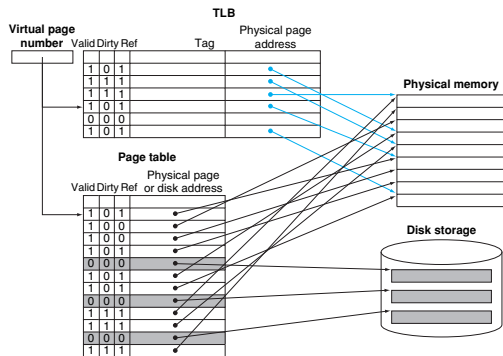

The TLB acts as a cache of the page table for the entries that map to physical pages only [11]

## TLB

- TLB is a cache, it must have a tag field
- If TLB miss, check the page table
- Typical values:
  - TLB size: 16-512 entries
  - Block size: 1-2 page table entries
  - Miss penalty: 10-100 clock cycles
  - Miss rate: 0.01%-1%

# Virtual memory

Putting it all together: Virtual memory, TLBs, and Caches

## Interaction

- Virtual memory and cache systems work together
- Under the supervision of the operating system

## Best case

Virtual address translated by TLB, sent to cache where data is found, retrieved and sent back to the processor

## Worst case

Miss in all three components: TLB, page table, cache

# Virtual memory

TLB	Page table	Cache	Possible? If so, under what circumstance?
Hit	Hit	Miss	Possible, although the page table is never really checked if TLB hits.
Miss	Hit	Hit	TLB misses, but entry found in page table; after retry, data is found in cache.
Miss	Hit	Miss	TLB misses, but entry found in page table; after retry, data misses in cache.
Miss	Miss	Miss	TLB misses and is followed by a page fault; after retry, data must miss in cache.
Hit	Miss	Miss	Impossible: cannot have a translation in TLB if page is not present in memory.
Hit	Miss	Hit	Impossible: cannot have a translation in TLB if page is not present in memory.
Miss	Miss	Hit	Impossible: data cannot be allowed in cache if the page is not in memory.

The possible combinations of events in the TLB, virtual memory system and cache [11]

# Virtual memory

## Implementing protection



### Context

I Sharing a single main memory by multiple processes

Three basic capabilities:

- 1 *Supervisor mode (or kernel mode)*: mode indicating that a running process is an operating system process.
- 2 Processor state readable (but not writable) by a user process: user/supervisor mode bit + page table pointer + TLB
- 3 From user mode to supervisor mode (and vice versa):
  - *System call*: special instruction that transfers control from user mode to a dedicated location in supervisor code space, invoking the exception mechanism in the process
  - *Supervisor exception return*: resets to user mode

# Virtual memory

## Implementing protection



### Context

I Sharing a single main memory by multiple users

## Preventing reading and writing by another (user) process

- Each process has its own virtual space
- The operating system keeps the page tables
- The user process cannot change its own page table
- All page tables placed in a protected address space

# Virtual memory

## Context switch

### Definition

*Context switch*: changing of the internal state of the processor to allow a different process to use the processor that includes saving the state needed to return to the currently executing process

### Overhead

- clear TLB entries
- Inefficient when high process switch rate

### Process identifier

- Concatenated to the tag
- TLB hit when
  - Page number + process identifier match



# Virtual memory

## Memory hierarchy design challenges

<b>Design change</b>	<b>Effect on miss rate</b>	<b>Possible negative performance effect</b>
Increases cache size	Decreases capacity misses	May increase access time
Increases associativity	Decreases miss rate due to conflict misses	May increase access time
Increases block size	Decreases miss rate for a wide range of block sizes due to spatial locality	Increases miss penalty. Very large block could increase miss rate

Source: [11]

# Virtual memory

## Summary

### Virtual memory

- Manage caching between the main memory and secondary memory
- Virtual address (beyond physical address)
- Share main memory between several processes, users with protections

### High cost of page fault

Miss rate reduced by

- Large page: spatial locality ↘ miss rate
- Fully associative mapping between virtual and physical addresses
- LRU replacement technique (OS)
- Write-back scheme
- TLB: cache for translations

# The future

Still ever increasing technology achievements

Three technologies as the leading contenders [7] (2014):

- STT-RAM (spin-transfer torque RAM) [Mos05]
- PCM (phase-change memory) [Rao08, Lee09]
- Memristor [Stru08]

## Emerging nonvolatile memory

spin torque transfer random access memory (STT-RAM), phase change memory (PCM), resistive random access memory (RRAM), racetrack memory (RM), ferromagnetic RAM (FeRAM), etc.

Guangyu Sun, Jishen Zhao, Matt Poremba, Cong Xu, Yuan Xie, *Memory that never forgets: emerging nonvolatile memory and the implication for architecture design*, National Science Review, July 2018

# The future

Still ever increasing technology achievements

**Embedded**  
COMPUTING DESIGN

## Arm Debuts eMRAM IoT test chip with Samsung, Cadence

 BRANDON LEWIS  MAY 15, 2019

**SAMSUNG FOUNDRY FORUM.** Arm, Samsung Foundry, Cadence, and Sondrel have collaborated on the Musca-S1, a 28 nm fully-depleted silicon-on-insulator (FD-SOI) embedded MagnetoResistive RAM (eMRAM) test chip based on Arm Cortex-M33 IP. The Musca-S1 test chip and an accompanying development board enable IoT SoC designers to evaluate eMRAM technology, which can easily scale below 40 nm to support a broad range of memory and power requirements.

Source: [arm.com](https://arm.com)

# The future

## 3D XPoint

4th August 2015

## New memory technology is 1,000 times faster

Intel and Micron have unveiled "3D XPoint" – a new memory technology that is 1,000 times faster than NAND and 10 times denser than conventional DRAM.

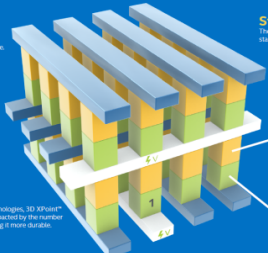

The diagram illustrates the 3D XPoint technology structure. It shows a grid of vertical pillars (memory cells) arranged in a 3D stack. Each pillar is composed of multiple layers of different materials, represented by various colors (blue, yellow, green, orange). The pillars are connected by horizontal lines representing word lines and bit lines. The diagram is set against a blue background with white text and lines pointing to specific components.

### 3D XPoint™ Technology: An Innovative, High-Density Design

**Cross Point Structure**  
Perpendicular wires connect submicroscopic columns. An individual memory cell can be addressed by selecting its top and bottom wire.

**Stackable**  
These thin layers of memory can be stacked to further boost density.

**Non-Volatile**  
3D XPoint™ Technology is non-volatile—which means your data doesn't go away when your power goes away—making it a great choice for storage.

**Selector**  
Whereas DRAM requires a transistor at each memory cell—making it big and expensive—the amount of voltage sent to each 3D XPoint™ Technology selector enables its memory cell to be written to or read without requiring a transistor.

**High Endurance**  
Unlike other storage memory technologies, 3D XPoint™ Technology is not significantly impacted by the number of write cycles it can endure, making it more durable.

**Memory Cell**  
Each memory cell can store a single bit of data.

# The future

## 3D XPoint

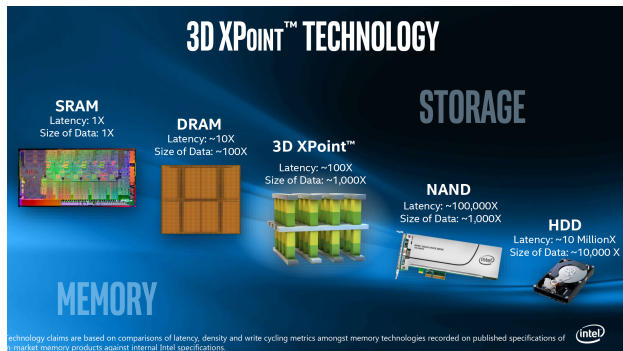

Commercial product: Optane SSD PC P4800X

# The future

## Hybrid Memory Cube

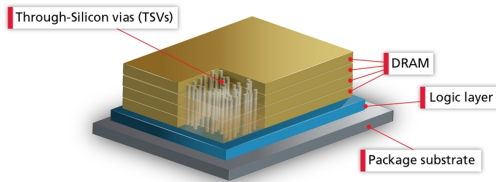

HMC Memory Chip Architecture

[https://community.cadence.com/cadence\\_blogs\\_8/b/ip/posts/what-s-new-with-hybrid-memory-cube-hmc](https://community.cadence.com/cadence_blogs_8/b/ip/posts/what-s-new-with-hybrid-memory-cube-hmc)

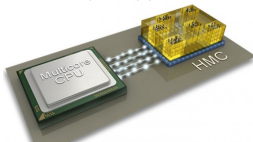

# The future

Still ever increasing technology achievements

## Still...

- more than 80% of the chip area is dedicated to caches, memories, memory controllers, interconnects and so on, whose sole purpose is to buffer data or control the buffering of data [1]
- ⇒ workarounds which are making systems ever more complex
- more than 62% of the entire measured system energy is spent on moving data between memory and the computation units [1]

Enabling the continued performance scaling of smaller systems requires significant research breakthroughs in three key areas [6]

- 1 power efficiency
- 2 programmability
- 3 execution granularity



*Down with Hierarchy!*

# The future



## Stop or reduce moving data

Process the data where it is: in the memory!

## AI workloads

Low arithmetic intensity, lots of memory accesses



## Sort this out!

Computing-In-Memory, Processing In Memory, In-memory computing,  
Logic In Memory, Near-Memory Computing, Intelligent Memory,  
Smart memories, Near-memory processing, Active memory, Memory-driven computing

# Classification

Classification proposed in [10]

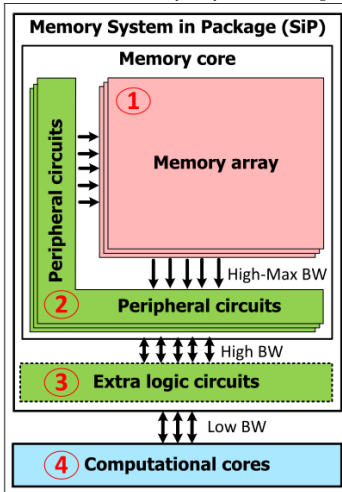

- 1 CIM-Array (CIM-A): the computing result is produced within the array
- 2 CIM-Periphery (CIM-P): the computing result is produced within the peripheral circuitry
- 3 Computation-Outside-Memory Near (COM-N): inside the memory SiP (System in Package)
- 4 Computation-Outside-Memory Far (COM-F): traditional computational cores

[10] H. A. D. Nguyen, J. Yu, M. A. Lebdeh, M. Taouil, S. Hamdioui, and F. Catthoor. *A classification of memory-centric computing*. J. Emerg. Technol. Comput. Syst., 16(2), jan 2020.

# Processing close to memory

Back to the future!

## Hitting the Memory Wall: Implications of the Obvious

Wm. A. Wulf

Sally A. McKee

Department of Computer Science

University of Virginia

{wulf | mckee}@virginia.edu

December 1994

## Processing in Memory: The Terasys Massively Parallel PIM Array

Maya Gokhale  
David Sarnoff Research Center\*

Bill Holmes and Ken Lobst  
Supercomputing Research  
Center

\*The work reported here was done while the author was at the Supercomputing Research Center, Bowie, Maryland.

**S**IMD processor arrays provide superior performance on fine-grained massively parallel problems in which all parallel threads do the same operations most of the time. However, this fine-grained synchrony limits the application space of SIMD (single instruction, multiple data) machines. If there are many alternative data-dependent actions among the parallel threads, the total execution time is the sum of the alternatives rather than the maximum single-thread execution time. Additionally, if the application is not inherently load-balanced, performance can degrade seriously: Most of the processors

# Processing close to memory

Where to compute then?

## In DRAM

- Processing in memory: inside DRAM (UpMem)
- In-memory computing primarily relies on keeping data in a server's RAM as a means of processing at faster speeds

A promotional banner for UpMem. The background is a dark, stylized image of a circuit board with the word "DATA" in large, glowing green letters. In the top left corner is the UpMem logo, which consists of the letters "up" in black and "mem" in white on a yellow square. In the top right corner, there are navigation links: "TECHNOLOGY", "DEVELOPER", "USE CASES", "NEWS", and "COMPANY". The main headline is "Our disruptive Processing-In-Memory solution boosts your big data applications" in large white text. Below the headline is a sub-headline: "Our Processing-In-Memory solution, the 1st efficient scalable programmable acceleration solution, accelerates on average 20 times big data applications, and reduces energy consumption and costs by a similar factor." data-bbox="65 433 925 863"/>

**up mem**

TECHNOLOGY DEVELOPER USE CASES NEWS COMPANY

## Our disruptive Processing-In-Memory solution boosts your big data applications

Our Processing-In-Memory solution, the 1st efficient scalable programmable acceleration solution, accelerates on average 20 times big data applications, and reduces energy consumption and costs by a similar factor.

Source: <https://www.upmem.com/>

# Processing close to memory

Where to compute then?

## In SRAM

- X-SRAM: Enabling In-Memory Boolean Computations in CMOS Static Random Access Memories [4] (2018)
  - 75% of memory accesses can be saved
- XNOR-SRAM: In-Memory Computing SRAM Macro for Binary/Ternary Deep Neural Networks [9] (2018)
  - 33X better energy and 300X better energy-delay product

## In cache

- Compute cache [3] (2017)
  - performance by  $1.9\times$  and reduce energy by  $2.4\times$
  - $54\times$  throughput,  $9\times$  dynamic energy savings

# Memory-Driven Computing

THE machine

## HP bets it all on The Machine, a new computer architecture based on memristors and silicon photonics

By Sebastian Anthony on June 11, 2014 at 11:30 am | [39 Comments](#)

## What happened to the HP machine?

Anyone remember the HP announcement about 'the machine'? Billy MacInnes does and he wonders just what has happened to the grand project

HP Enterprise unveils The Machine, a single-memory computer capable of addressing 160 terabytes

DEAN TAKAHASHI @DEANTAK MAY 16, 2017 6:01 AM

### WHAT'S NEW

HPE Persistent Memory, available in 128, 256, and 512 GB kits, features Intel® Optane™ DC Persistent Memory to approach the speed of traditional DRAM with the persistence of storage, ensuring high capacity, high performance, and ongoing data safety — even in the event of an interruption in power due to an unexpected power loss, system crash, or normal system shutdown.

# The future

## Active Research

Displaying results 1-25 of 119 for **(("Document Title":in-memory) AND "Document Title":processing)** ✕

▼ **Filters Applied:** Conferences ✕ Journals & Magazines ✕

Displaying results 1-25 of 136 for **(("Document Title":in-memory) AND "Document Title":computing)** :

▼ **Filters Applied:** Conferences ✕ Journals & Magazines ✕

Year	In-memory AND processing	In-memory AND computing
2021	49	202
2020	43	112
2019	48	76
2018	30	51
2017	31	32
2016	17	18
2015	9	16
2014	3	4
2013	1	4
2012	0	0
2011	0	0
1995-2010	18	3



# Conclusion

## Memory system

- Central component of any digital device
- Keep the pace with faster processors
  - Principle of locality
  - Memory hierarchy

## Von Neumann architecture

Computer architecture heavily rely on a 70 years old scheme

Many additional features to get higher performance

## The future

- Still rely on technology improvements?
- How to stop useless and (energy) wasteful memory accesses?
- New memory organisations and computing paradigms

**THE MEMORY REMAINS !**

# References I

- [1] 'It's the memory, stupid': A conversation with Onur Mutlu - Press.
- [2] Octet (computing), Feb. 2019.  
Page Version ID: 882550034.
- [3] S. Aga, S. Jeloka, A. Subramaniyan, S. Narayanasamy, D. Blaauw, and R. Das.  
**Compute Caches.**  
*In 2017 IEEE International Symposium on High Performance Computer Architecture (HPCA)*, pages 481–492, Feb. 2017.
- [4] A. Agrawal, A. Jaiswal, C. Lee, and K. Roy.  
**X-SRAM: Enabling In-Memory Boolean Computations in CMOS Static Random Access Memories.**  
*IEEE Transactions on Circuits and Systems I: Regular Papers*, 65(12):4219–4232, Dec. 2018.
- [5] H. Carl, V. Zvonko, Z. Safwat, and M. Naraiğ.  
**Computer Organization and Embedded Systems.**  
McGraw-Hill Education, New York, NY, 6 edition edition, Jan. 2011.
- [6] B. Dally.  
**Power, Programmability, and Granularity: The Challenges of ExaScale Computing.**  
*In 2011 IEEE International Parallel Distributed Processing Symposium*, pages 878–878, May 2011.
- [7] A. Hasan, F. Paolo, F. Eitan, K. Hironori, L. Danny, L. Phil, M. Arif, M. Dejan, and S. Karsten.  
IEEE CS 2022 Report.
- [8] B. Jacob, S. Ng, and D. Wang.  
**Memory Systems: Cache, DRAM, Disk.**  
Morgan Kaufmann, Burlington, MA, 1 edition edition, Sept. 2007.
- [9] Z. Jiang, S. Yin, M. Seok, and J. Seo.  
**XNOR-SRAM: In-Memory Computing SRAM Macro for Binary/Ternary Deep Neural Networks.**  
*In 2018 IEEE Symposium on VLSI Technology*, pages 173–174, June 2018.

# References II

- [10] H. A. D. Nguyen, J. Yu, M. A. Lebdeh, M. Taouil, S. Hamdioui, and F. Catthoor.  
A classification of memory-centric computing.  
*J. Emerg. Technol. Comput. Syst.*, 16(2), jan 2020.
- [11] D. A. Patterson and J. L. Hennessy.  
*Computer Organization and Design RISC-V Edition: The Hardware Software Interface*.  
Morgan Kaufmann, 2017.
- [12] Sidhartha.  
Classification of Semiconductor Memories and Computer Memories, July 2015.