



HAL
open science

Active Fault Diagnosis based on Adaptive Degrees of Freedom χ^2 -statistic method

Quoc Hung Lu, Soheib Fergani, Carine Jauberthie

► **To cite this version:**

Quoc Hung Lu, Soheib Fergani, Carine Jauberthie. Active Fault Diagnosis based on Adaptive Degrees of Freedom χ^2 -statistic method. 8th International Conference on Control, Decision and Information technologies (CoDIT'22), May 2022, Istanbul, Turkey. 10.1109/CoDIT55151.2022.9804156 . hal-03689596

HAL Id: hal-03689596

<https://hal.science/hal-03689596v1>

Submitted on 7 Jun 2022

HAL is a multi-disciplinary open access archive for the deposit and dissemination of scientific research documents, whether they are published or not. The documents may come from teaching and research institutions in France or abroad, or from public or private research centers.

L'archive ouverte pluridisciplinaire **HAL**, est destinée au dépôt et à la diffusion de documents scientifiques de niveau recherche, publiés ou non, émanant des établissements d'enseignement et de recherche français ou étrangers, des laboratoires publics ou privés.

Active Fault Diagnosis based on Adaptive Degrees of Freedom χ^2 -statistic method

Quoc-Hung Lu¹, Soheib Fergani¹, Carine Jauberthie¹

Abstract—This paper is concerned with an active fault diagnosis method is developed based on an adaptive fault detection approach using χ^2 -statistics [1]. The system under consideration is linear discrete time-variant with sensor faults in the framework of mixed uncertainties (stochastic noises and bounded uncertainty for parameter matrices). The proposed method enhances the fault detection performance and provides the ability of localization and estimation of the detected fault. It provides also an on-line fault diagnosis with no delay in time instant with the computation time depending only on the computer performance.

I. INTRODUCTION

Fault diagnosis is becoming nowadays a functionality of utmost importance for modern systems. Including the fault detection as a substantial task, fault diagnosis is characterized by its ability of fault isolation and identification that allows the system to react in real time.

The fault diagnosis can be organised in two general categories: model-based (analytical model based on a deeper understanding of the system), and non-model based (heuristic knowledge). In the field of model-based fault diagnosis, two approaches can be considered: *passive* and *active fault diagnosis* (AFD). The passive approach has been introduced very early in 1970's by [2], [3], [4] and has been extensively investigated. A general survey on these passive approaches can be found in [5] and [6]. On the other hand, few works have focused on the active approach that has been developed more recently. In [7], an approach using auxiliary signal design for failure detection has been introduced, and where the key terminology "active failure detection" (AFD) appears. Also, ([8], [9], [10], [11],...) use the AFD terminology. To the best of our knowledge until now, [12] is a rather complete and recent survey dealing with the AFD approach.

A key idea of AFD is to use *auxiliary input signals* that are injected into the monitored system in order to improve the quality of decision making stage of the fault diagnosis. This technique was investigated in several researches around 1990, well before the release of the AFD terminology (more details in [12]). Also, the AFD approach can be classified into groups based on different relevant features as: the deterministic (norm bounded)/probabilistic (based on uncertainty description), the fixed/variable finite time interval or infinite time interval (based on the length of time interval in which auxiliary signals are designed). A list up to date and non exhaustive of related researches can be found in [12], [13].

The relevant issue of AFD approach is that the injection of auxiliary signals into the monitored system disturbs the outputs to be controlled both in the fault-free case as well as in the faulty case [11]. It should be ensured that auxiliary signals do not drive the monitored system out of desired control performance specifications. Therefore, there is a trade-off between the fault diagnosis quality improvement and a minimal disturbance of the controlled outputs.

Very recently, authors have introduced *Adaptive degrees of freedom χ^2 -statistic* (ADFC) using the optimal upper bound kalman filter and the χ^2 -statistics. It allows to provide a significantly enhance fault detection for systems subject to mixed uncertainties (bounded and stochastic), see [1].

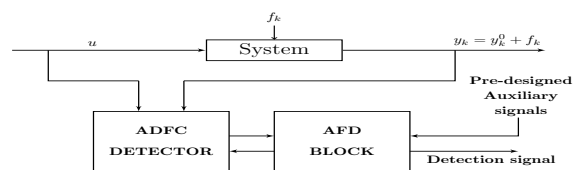

Fig. 1: AFD general block diagram.

In this paper, a novel AFD method based on the *Adaptive degrees of freedom χ^2 -statistic* (ADFC) is presented. The proposed active strategy uses auxiliary signals to enhance fault detection performance of the ADFC method (see Fig. 1). Additionally, it provides the ability of the estimation and localization of the detected fault. It uses the ADFC method as its main fault detector, called *ADFC detector* in this article, and therefore deals with a dynamical system with mixed uncertainties. More precisely, in this study, a linear discrete time system concerning both stochastic and bounded uncertainties in system parameters and sensor fault context are handled. The main contribution is that the auxiliary signals are not injected into the monitored system but provided only to the diagnoser whenever a fault is detected. Thanks to characteristics of ADFC detector, using these auxiliary signals, the diagnoser can decide whether the detected signal is a false alarm or not and hence reduces false alarms. In the case of positive confirmation, the diagnoser localizes and estimates the detected fault. Then, the estimated fault is returned backwardly to the diagnoser to compensate for the actual fault effect to the next iteration, which also enhances the fault detection. Furthermore, since auxiliary signals are not injected to the monitored systems, the undesired system disturbance due to auxiliary signals is avoided.

The paper is organized as follows: Section I provides an overview and a general framework for the study. In Section II,

¹ LAAS-CNRS, Université de Toulouse, CNRS, UPS, Toulouse, France. Corresponding author: qhlu@laas.fr

the considered problem is formulated. Section III presents the main contribution which is the proposed AFD method. Section IV applies the method to the Bicycle vehicle application. Section V is the conclusion.

II. PROBLEM FORMULATION

In this section, the problem formulation for the fault diagnosis purpose is addressed. Based on that, objectives, scope and resolution methodology are determined. In general, a standard fault diagnosis resolution addresses both the fault detection and isolation (FDI) and the fault estimation (FE).

Let's start by presenting briefly the notations used in the whole article (including Algorithms). A real positive semidefinite matrix A is denoted by $A \succeq 0$. For two real square matrices M, N of the same size, M is an upper bound of N , denoted $N \preceq M$, if and only if $M - N \succeq 0$. For a non empty set Ω of square matrices, K is an upper bound of Ω , denoted $\Omega \preceq K$, if and only if $M \preceq K, \forall M \in \Omega$. A real interval matrix $[X]$ of dimension $p \times q$ is a matrix with real interval components $[x_{ij}]$, $i = 1 : p, j = 1 : q$. Write $X \in [X]$ to indicate a point matrix $X = (x_{ij})$ belonging element-wise to $[X]$. Define: $\bar{X} \equiv \sup([X]) = (\sup([x_{ij}]))$, $\underline{X} \equiv \inf([X]) = (\inf([x_{ij}]))$, $\text{mid}([X]) = (\bar{X} + \underline{X})/2$, $\text{rad}([X]) = (\bar{X} - \underline{X})/2$ and $\text{width}([X]) = \bar{X} - \underline{X}$. Let $[X]$ be an $n \times n$ real interval matrix, denote: $S([X]) = \{X \in [X] : X = X^T\}$, $S_+([X]) = \{X \in S([X]) : X \succeq 0\}$. Basic interval operators $\diamond \in \{+, -, \times, \div\}$ defined in [14] can be used to compute directly all operations $[u] \diamond [v]$ and $\alpha \diamond [u]$, for real intervals $[u], [v]$ and $\alpha \in \mathbb{R}$, without any further approximation algorithm. More general operators are constructed by means of inclusion function [14]. In practice, the package Intlab developed for Matlab is used.

Consider the linear discrete time dynamical system:

$$\begin{cases} x_k = A_k x_{k-1} + B_k u_k + w_k, \\ y_k = C_k x_k + D_k u_k + v_k + f_k, \end{cases} \quad k \in \mathbb{N}^*, \quad (1)$$

where $x_k \in \mathbb{R}^{n_x}$ and $y_k \in \mathbb{R}^{n_y}$ represent state variables and measures respectively, $u_k \in \mathbb{R}^{n_u}$ inputs, $w_k \in \mathbb{R}^{n_x}$ state noises, $v_k \in \mathbb{R}^{n_y}$ measurement noises and $f_k \in \mathbb{R}^{n_y}$ sensor faults. Each of the f_k 's components corresponds to a sensor and f_k can be composed by multiple faults (some or all sensors are faulty) or single fault (only one sensor is faulty).

Assumptions (A1): w_k, v_k are centered Gaussian vectors with covariance matrices Q_k and R_k . Matrices $A_k, B_k, C_k, D_k, Q_k, R_k$ are unknown, deterministic and belonging to a given bounded interval matrices $[A], [B], [C], [D], [Q]$ and $[R]$ respectively. The initial state x_0 is also Gaussian with mean μ_0 and covariance matrix P_0 . In addition, $x_0, \{w_1, \dots, w_k\}$ and $\{v_1, \dots, v_k\}$ are assumed to be mutually independent.

Assumption (F1). The fault vector is of the form of single fault, that is $f_k = b \cdot e_{j_0} \equiv f_{k,j_0}^b$ where $b \in \mathbb{R}$ and e_{j_0} is the j_0 -th column of the corresponding identity matrix, $j_0 \in \{1, \dots, n_y\}$.

Assumption (F2). For each chain $j \in \{1, \dots, n_y\}$, there exists a value $b_j^* > 0$ so that the detection signal π_k satisfies

$$\begin{aligned} \mathbb{P}(\pi_k = 1 \mid |b| \geq b_j^*) &\geq p_j^*, \\ \mathbb{P}(\pi_k = 0 \mid |b| < b_j^*) &\geq \tilde{p}_j^*, \end{aligned}$$

with acceptable probabilities p_j^*, \tilde{p}_j^* , e.g. $p_j^* = \tilde{p}_j^* = 0.95$.

Remark 1. In the notation f_{k,j_0}^b , b means for a dependence index of f_k and not a power. The assumption (F1) is considered as it is the simplest but indispensable case for a FDI and FE problem. The assumption (F2) raises naturally for any fault detection method. As the fault value b has a large magnitude, the fault is easily detected ($\pi_k = 1$) and vice versa. Thus, the thresholds b_j^* 's always exist. The values b_j^*, p_j^* and \tilde{p}_j^* are chosen based on the application and the considered scenario.

Problem. Consider the system (1) with assumptions (A1), (F1) and (F2).

- P1.** For a detected fault, determine (isolate) the chain on which it occurs and estimate its value.
- P2.** Detect (diagnosis if possible) *incipient faults*, i.e. the ones with small magnitudes ($|b| < b_j^*$), in the early stage.

The problem P1 focuses on the diagnosis of large faults ($|b| \geq b_j^*$) which are detected almost always (with high probabilities) and some moderate ones ($|b| < b_j^*$) which are detected occasionally (with small probabilities). The *detected signals* ($\pi_k = 1$) include also false alarms. Beside the ability of isolation and estimation of the real faults, a good fault diagnosis scheme solving P1 might help to reduce false alarms.

Incipient faults are naturally harder to detect. The problem P2 can be seen as solved (or partially solved) by a scheme :

- 1) reducing thresholds b_j^* 's as small as possible,
- 2) solving the problem P1 using reduced thresholds b_j^* 's with good/acceptable performance,
- 3) reducing false alarms.

A perfect solution detecting all incipient faults might be unrealistic.

III. ACTIVE FAULT DIAGNOSIS SCHEME FOR ADAPTIVE DEGREES OF FREEDOM χ^2 -STATISTIC METHOD

In this section, an AFD scheme applied to a discrete dynamical system based on the ADFC method dealing with sensor additive single fault is developed. This scenario corresponds to the type 2 of error (single fault) presented in [1]. The scheme focuses to handle the problem P1 and but also solves the problem P2.

A. Motivation

The ADFC method is developed based on Theorems 1-2 of [1] and summarized by Algorithms 1-2 presented below (also introduced in [1]). The Algorithms concern the system (1) with assumptions (A1). ADFC method is a fault detection method that can detect multiple and single faults. The fault values can be positive or negative. Consequently, it is compatible also to assumptions (F1) and (F2). In the ADFC method, Algorithm 2, namely OUBIKF which means for *Optimal Upper Bound Interval Kalman Filter*, is used as a residual generator providing $[r_k] = y_k - [\hat{y}_k]$. The whole fault detection

Algorithm 1 ADFC METHOD TO LINEAR SYSTEM [1]

- 1: **Initialization:** $[\hat{x}_{0|0}], \mathcal{P}_{0|0}, [A], [B], [C], [D], [Q], [R], \alpha, u_k, y_k, k = 1, 2, \dots, N.$
- 2: **for** $k = 1, 2, 3, \dots, N$ **do**
- 3: Use Algorithm 2 to obtain: $[\hat{x}_{k|k-1}], [P_{k|k-1}].$
- 4: $[r_k] = y_k - [C][\hat{x}_{k|k-1}] - [D]u_k$
- 5: $[S_k] = [C][P_{k|k-1}][C]^T + [R]$
- 6: Find a_k using Theorem 2 of [1] s.t. : $S_+([S_k]) \preceq a_k I.$
- 7: $U_k = \sup\{\text{abs}([r_k]^T[r_k]/a_k)\}$
- 8: $\kappa_k = \sum_{i=1}^{n_y} \text{width}([r_k(i)])/n_y = \text{mean}\{\text{width}([r_k])\}$
- 9: Find δ_k s.t.: $\mathbb{P}(\chi^2(\kappa_k n_y) > \delta_k) = \alpha.$
- 10: Detection signal : $\pi_k = \mathbb{I}(U_k > \delta_k).$
- 11: **end for**

(*) : $\mathbb{I}(x)$ is the indicator function which equal to 1 if the conditions x are true and vanishes otherwise.

Algorithm 2 OUBIKF [1]

- 1: **Initialization:** $[\hat{x}_{0|0}], \mathcal{P}_{0|0}, [A], [B], [C], [D], [Q], [R], u_k, y_k, k = 1, 2, 3, \dots, N.$
 - Find n_0 the number of non zero radius of $[C].$
 - Find γ such that $S_+([R]) \preceq \gamma I.$
 - 2: **for** $k = 1, 2, 3, \dots, N$ **do**
 - 3: $[\hat{x}_{k|k-1}] = [A][\hat{x}_{k-1|k-1}] + [B]u_k$
 - 4: $[P_{k|k-1}] = [A]\mathcal{P}_{k-1|k-1}[A]^T + [Q]$
 - 5: Find α_k using Theorem 2 of [1] s.t.: $S_+([P_{k|k-1}]) \preceq \alpha_k I$
 - 6: Choose $\beta_k > 0$ and $\sigma_k > 0$
 - 7: $S_k = \text{mid}([C])\text{mid}([C])^T + \frac{\gamma}{\alpha_k(1+n_0/\beta_k)} I$
 $+ \frac{\beta_k + n_0\sigma_k}{1+n_0/\beta_k} \text{Diag}\{\text{rad}([C])\text{rad}([C])^T\}$
 - 8: $K_k = \text{mid}([C])^T S_k^{-1}$
 - 9: $[\hat{x}_{k|k}] = (I - K_k[C])[\hat{x}_{k|k-1}] + K_k(y_k - [D]u_k)$
 - 10: $\mathcal{P}_{k|k} = (I - K_k\text{mid}([C]))\alpha_k(1 + n_0/\beta_k)$
 - 11: **end for**
-

process of this method is summarized in Algorithm 1 and called in brief the *ADFC detector* as mentioned so far.

Let $k \geq 1$, $y_k = y_k^0 + f_k$ where y_k^0 is the fault-free measurement. In the faulty case, $f_k = b.e_{j_0}$ with $b \neq 0$ and $j_0 \in \{1, \dots, n_y\}$. Also, one gets $[r_k] = [r_k^0] + f_k$ and $[\hat{x}_{k|k}] = [\hat{x}_{k|k}^0] + K_k f_k$. The developed AFD scheme is motivated by following questions:

- (Q1)** Given that the ADFC detector has detected the existence of a fault $f_k = b.e_{j_0}$, what happens if one can add (by chance!) a quantity $\tilde{f}_k = -b.e_{j_0}$ to the measurement y_k to obtain \tilde{y}_k then rerun the ADFC detector with \tilde{y}_k ?
- (Q2)** In the same way, what happens if one adds each of following quantities to y_k and rerun the ADFC detector:
- $\tilde{f}_k = b_1 e_{j_0}$ where $b_1.b > 0$,
 - $\tilde{f}_k = b_2 e_{j_0}$ where $b_2.b < 0$,
 - $\tilde{f}_k = b_3 e_j$ where $j \neq j_0$?

Assuming that the ADFC detector has a good enough performance, for **(Q1)**, detection signal π_k equals 0 with the use of \tilde{y}_k . Then consider **(Q2)**. In the first case, the fault value has been augmented its magnitude by an additive term of the same sign, so the ADFC detector gives $\pi_k = 1$ with high

probability. In the second case, regarding assumption (F2), one gets with high probability that $\pi_k = 0$ if $|b_2 + b| < b_{j_0}^*$ and $\pi_k = 1$ if $|b_2 + b| \geq b_{j_0}^*$. For the last case, it is worthy to note that:

- add a term b_3 to the j -th element of y_k is equivalent to add b_3 to the j -th element of $[r_k]$,
- the statistic used in ADFC detector is $U_k = \sup\{\text{abs}([r_k]^T[r_k]/a_k)\}.$

Since $j \neq j_0$, by assumption, the j -th element of $[r_k]$, says $[r_k(j)]$, is fault-free. Therefore, $[r_k(j)]$ is centered nearby 0. With the additive term b_3 , whatever it is negative or positive, $[r_k(j)]$ deviates more from 0 while its width remains unchanged provided that $|b_3|$ is not too small. This implies that U_k takes a greater value while the threshold δ_k determined by $\mathbb{P}[\chi^2(\kappa_k n_y) > \delta_k] = \alpha$ is unchanged since κ_k, n_y and α are unchanged (Algorithm 1). Thus, $\pi_k = 1$ also in the last case of **(Q2)**.

B. Methodology and Scheme

In the considered framework, a sensor fault is characterized by a fault value b and the chain j on which it occurs. Denote a detection signal associated to an occurred fault $f_{k,j}^b$ using the ADFC detector by $\pi_k(f_{k,j}^b)$. In addition, since the ADFC detector performs also with the multi faults case, we also use the notation $\pi_k(f_{k,j}^b + f_{k,j'}^{b'})$, $j \neq j'$, to designate the detection signal associated to faults occurring on two different chains.

Let $\Delta \in [0, \min_{j=1:n_y}\{b_j^*\}]$ and $M \in \mathbb{N}^*$ so that $M.\Delta$ is superior to maximum fault magnitude we want to estimate. Generate auxiliary signals, denoted *fictive faults*, as follows:

$$\tilde{f}_{k,j}^{q\Delta} = q.\Delta.e_j, \quad q = -M : M, \quad j = 1 : n_y.$$

If a fault occurs on a chain $j_0 \in \{1, \dots, n_y\}$, which means $f_{k,j_0}^b = b.e_{j_0} \neq \mathbf{0}$, and assuming that $0 < |b| \leq M.\Delta$, there exists a $q^* \in \{-M, \dots, M\}$ so that

$$q^*.\Delta < b \leq (q^* + 1).\Delta.$$

This implies that $0 \leq |b - (q^* + i).\Delta| \leq \Delta$, $i \in \{0, 1\}$. Therefore, for $\mathcal{I} = \{-\lfloor b_{j_0}^*/\Delta \rfloor + 1, \dots, \lfloor b_{j_0}^*/\Delta \rfloor\}$,

$$\pi_k \left(f_{j_0}^b + \tilde{f}_{j_0}^{b_i} \right) = 0, \quad b_i = -(q^* + i).\Delta, \quad i \in \mathcal{I}, \quad (2)$$

with high probability regarding discussions of **(Q1)** and **(Q2)**. Also, we have with high probability:

$$\begin{aligned} \pi_k \left(f_{j_0}^b + \tilde{f}_{j_0}^{b_i} \right) &= 1, \quad b_i = -(q^* + i).\Delta, \quad i \notin \mathcal{I}, \\ \pi_k \left(f_{j_0}^b + \tilde{f}_{j_0}^{q\Delta} \right) &= 1, \quad q \in \{-M : M\}, \quad j \neq j_0. \end{aligned}$$

Remark 2. The so called "with high probability" mentioned above depends on the probabilities p_j^*, \tilde{p}_j^* of assumptions **(F2)** and the performance of the ADFC detector represented by DR, FAR or EFF indexes defined in [1] and recalled in Section IV.

The developed AFD scheme is explained via the diagram in Fig.2 and Algorithm 3. Regarding Fig.2, the ADFC detector includes OUBIKF as its residual generator and the fault detection part of AFD block. It provides only detection signal

π_k at each iteration. From the figure, we note that when a fault occurs at a time instant k , it follows the feedback $[\hat{x}_{k|k}]$ and affects the residual at next iterations. Thus π_{k+1} reflects not only the existence of f_{k+1} but also the effect of previous fault f_k . The AFD scheme consists in using fictive faults as auxiliary inputs and providing them only to the AFD block and not to the monitored system. Thanks to these auxiliary inputs, the ADFC detector produces the *signature matrix*

$$\mathcal{S}_k = \left(\pi_k \left(f_{j_0}^b + \tilde{f}_j^{q\Delta} \right)_{j,q} \right) \equiv \left(\pi_{k,j}^q \right),$$

where $j = 1 : n_y$, $q = -M : M$ are row and column indexes respectively. Then the AFD block is equipped with a fault diagnosis part decoding \mathcal{S}_k to decide whether π_k equals 0 or 1, f_k is 0 or takes which estimated value. After that, the estimated fault \hat{f}_k is sent backwardly to OUBIKF in order to compensate for the fault effect to $[\hat{x}_{k|k}]$ and to the fault diagnosis at the next iteration. Without this fault feedback process, the fault diagnosis has a poor performance.

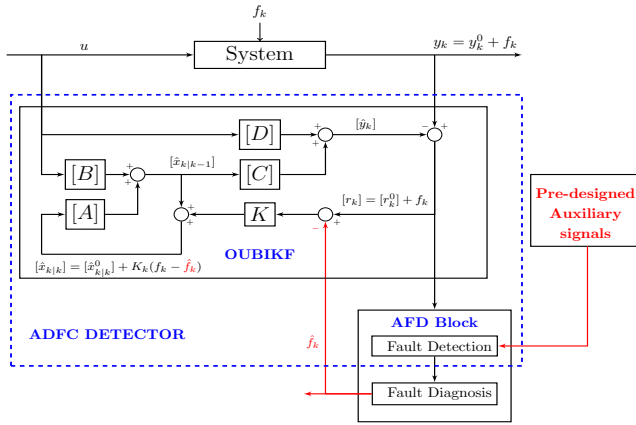

Fig. 2: Active Fault Diagnosis diagram using ADFC detector.

The fault diagnosis part of the AFD block is a signature matrix decoder. Its function is specified in Algorithm 3.

When \mathcal{S}_k has no zero element, all yielded detection signals are 1, in particular,

$$\pi_k \left(f_{j_0}^b + \tilde{f}_{j_0}^{b_i} \right) = 1, \quad b_i = -(q^* + i)\Delta, \quad i \in \mathcal{I},$$

which contradicts (2). In other words, it is almost the case that $\pi_k(f_{j_0}^b) = 1$ for all b nearby and including 0. Therefore, the detected signal $\pi_k = 1$ (line 3 of Algorithm 3) initially dispatched is a false alarm with high probability.

When \mathcal{S}_k has at least one zero element, the error chain is estimated as the one on which \mathcal{S}_k has the maximum number of zero elements, denoted by \hat{j}_0 . That is because a single fault at a chain j_0 may affect the behavior of residual $[r_k]$ on another chain $j \neq j_0$, however its effects on the chain j_0 is the stronger. Then, the fault is estimated as the additive inverse of the mean of all fictive faults $\tilde{f}_{k,j_0}^{q\Delta}$ with which $\pi_k \left(f_{j_0}^b + \tilde{f}_{j_0}^{q\Delta} \right) = 0$.

Denote the estimated fault as $\hat{f}_k = \hat{b} \cdot \mathbf{e}_{\hat{j}_0}$ and the diagnosed detection signal as $\hat{\pi}_k$. The diagnosis is called *r-accurate* if

$$\hat{j}_0 \equiv j_0 \quad \text{and} \quad |\hat{b} - b| \leq r, \quad (3)$$

Algorithm 3 AFD SCHEME FOR ADFC METHOD

1: Initialization:

$\Delta, M, B^* = \{b_j^*, j = 1 : n_y\}, \lambda,$
 $[\hat{x}_{0|0}], \mathcal{P}_{0|0}, [A], [B], [C], [D], [Q], [R], \alpha, \{u_k, y_k\}_{k=1:N}$

2: for $k = 1, 2, 3, \dots, N$ do

3: Use Algorithm 1 to get detection signal: π_k

4: if $\pi_k = 1$ then

5: $q = -M : M ; j = 1 : n_y ; \tilde{y}_{k,j}^q = y_k + q \cdot \Delta \cdot \mathbf{e}_j ;$
 6: Rerun Algorithm 1 with $\{\tilde{y}_{k,j}^q\}$ to obtain $\mathcal{S}_k = (\pi_{k,j}^q)$.

7: if \mathcal{S}_k has no zero element then

8: $\pi_k = 0$

9: else

10: $\hat{j}_0 = \operatorname{argmax}_{j=1:n_y} \sum_{q=-M}^M \pi_{k,j}^q$
 11: Find $I_0 \subseteq \{-M : M\}$ s.t. $\pi_{k,\hat{j}_0}^q = 0, \forall q \in I_0$

12: $\hat{b} = -\operatorname{mean}\{I_0\} \cdot \Delta ; \hat{f}_k = \hat{b} \cdot \mathbf{e}_{\hat{j}_0} ;$

13: if $|\hat{b}| \leq \lambda \cdot \min\{B^*\}$ then

14: $\pi_k = 0$

15: else

16: $\hat{f}_k = \operatorname{sign}(\hat{b}) \cdot \max\{|\hat{b}|, \operatorname{mean}(B^*)\} \cdot \mathbf{e}_{\hat{j}_0}$

17: $[\hat{x}_{k|k}] = [\hat{x}_{k|k}] - K \cdot \hat{f}_k$

18: end if

19: end if

20: end if.

21: end for

Note: The parameters in the second line of the initialization are required only for ADFC detector (Algorithm 1).

where $r > 0$ is a predetermined radius. This condition is also called the *r-accuracy*.

Next, in order to eliminate more false alarms and reinforce the estimation accuracy, a regularization is performed. Regarding the assumption (F2), ideally, a fault value $b \geq b_{j_0}^*$ is detected and hence \hat{b} must be at least close to $\min\{b_j^*, j = 1 : n_y\}$. So, if the estimated value \hat{b} is such that

$$|\hat{b}| \leq \lambda \cdot \min\{b_j^*, j = 1 : n_y\}, \quad \lambda \in [0, 1],$$

we consider that it is not consistent with assumption (F2) and hence \hat{b} is replaced by 0 and $\hat{\pi}_k = 0$ is dispatched. In the case

$$\lambda \cdot \min\{b_j^*, j = 1 : n_y\} < |\hat{b}| \leq \operatorname{mean}\{b_j^*, j = 1 : n_y\},$$

we consider that there is something intervening and lessening the estimated value \hat{b} . So \hat{b} is replaced by $\operatorname{mean}\{b_j^*, j = 1 : n_y\}$ and $\hat{\pi}_k = 1$ is dispatched. The value $\operatorname{mean}\{b_j^*, j = 1 : n_y\}$ is chosen as the replacing value because the actual faulty chain j_0 is not known, otherwise $b_{j_0}^*$ could be used. Finally, the estimated fault is fed backwardly to ADFC detector by subtracting the amount $K \hat{f}_k$ to $[\hat{x}_{k|k}]$.

IV. APPLICATION

In this section, the proposed method is applied in simulation to the *Bicycle vehicle model* ([15]) which was also used as the

simulation application in [1], that is:

$$\begin{bmatrix} \dot{\beta}(t) \\ \ddot{\psi}(t) \end{bmatrix} = \begin{bmatrix} \frac{-C_f - C_r}{m v} & 1 + \mu \frac{-l_r C_r - l_f C_f}{m v^2} \\ \frac{-l_r C_r - l_f C_f}{I_z} & \frac{-l_f^2 C_f - l_r^2 C_r}{I_z v} \end{bmatrix} \begin{bmatrix} \beta(t) \\ \dot{\psi}(t) \end{bmatrix} + \begin{bmatrix} \frac{C_f}{m v} & 0 & 0 & 0 \\ \frac{l_f C_f}{I_z} & \frac{1}{I_z} & \frac{S_r R t_r}{2 I_z} & -\frac{S_r R t_r}{2 I_z} \end{bmatrix} \begin{bmatrix} \delta \\ M_{dz} \\ T_{b_{rl}} \\ T_{b_{rr}} \end{bmatrix}$$

where $\beta(t)$ is the sideslip angle and $\psi(t)$ is the vehicle yaw which form the model state variables. This is a nonlinear continuous-time model which has been discretized/linearized and thus given under the form (1), where the state is $x_k = (x_k(1), x_k(2))^T = (\beta(k), \psi(k))^T$.

In the present simulation, the parameters $\sigma_k = 1$ and $\beta_k = 10^{-6}$ are applied inside the Algorithm 2. Other parameter settings and simulation procedure applied here are similar to those used in [1] without adjustment step.

To evaluate the fault detection performance, indicators introduced in [1] are used. Assume that system (1) is applied for N iterations among which faults occur in a region \mathcal{R} with length l ($0 \leq l \leq N$). The region \mathcal{R} may be a range or union of ranges but is called hereafter an *error range* for simplicity. Briefly,

- + *Detection Rate*: $DR = \sum_{k \in \mathcal{R}} \mathbb{I}(\pi_k = 1) / l \times 100\%$,
- + *False Alarm Rate*: $FAR = \sum_{k \notin \mathcal{R}} \frac{\mathbb{I}(\pi_k = 1)}{N - l} \times 100\%$,
- + *Efficiency*: $EFF = DR - FAR$.

Firstly, we verify the ADFC detector properties as mentioned in Section III-A and determine thresholds b_j^* 's of assumption (F2). In order to increase the detection rate, the parameter $\tilde{\kappa}_k = \lambda_k \text{mean}\{\text{width}([r_k])\}$ is applied in Algorithm 1 with $\lambda_k = a_k^{-1/2}$ is a scale parameter (a_k is determined in Algorithm 1). The results after 100 times of simulations are shown in the following table.

b	DR (%)			
	Chain 1	Chain 2	Chain 3	Chain 4
-40	100	100	100	98.2
-35	100	100	100	97.9
-30	100	100	100	97.1
-25	100	99.5	100	96.7
-20	99.7	98.6	100	96.5
-15	92.8	89.6	64.9	35.1
-10	48.3	38.7	22.2	16.2
-5	15.4	10.9	10.1	6.8
0	6.9	3.8	9.3	7.5
5	14.4	10.9	14.5	11.3
10	49.1	40.8	15.0	8.5
15	94.3	91.5	67.2	38.3
20	99.5	98.4	100	96.4
25	100	99.7	100	97.0
30	100	99.9	100	97.3
35	100	100	100	97.9
40	100	99.9	100	98

(FAR(%))

TABLE I: Detection rate of ADFC detector applied for Bicycle vehicle model.

It is shown that the ADFC method functions with either positive or negative fault values, the thresholds mentioned in assumptions (F2) are determined as $b_1^* = b_2^* = b_3^* = b_4^* = 20$ with probabilities beyond 0.96. Note that in the case of $b =$

0, there is in fact no fault, thus the corresponding detection rates shown in the table are actually false alarm rate (FAR(%)) which notation is noted right next to them.

Secondly, we continue the simulation to illustrate the AFD scheme performance. Other parameters chosen for Scheme 3 are: $\Delta = 5$, $M = 12$, $\lambda = 0.5$ and $\alpha = 0.03$.

Recall that the AFD scheme is dedicated to diagnose faults whose magnitudes beyond thresholds b_j^* 's. Thus, a fault value $b = -25$ is fixed. Then, four different faults $f_k = -25e_j$, $j = 1 : 4$, are tested. In each case, an error range of length 50 (time instants) are randomly chosen in which the fault occurs. Then the ADFC detector (Algorithm 1) is performed without and with AFD scheme. Thanks to that we can answer to several questions:

- (1) Does the AFD scheme enhance the fault detection of ADFC detector and help to reduce false alarms?
- (2) How well is the fault diagnosis provided by the AFD scheme ?

The first question is answered positively thanks to Fig.3 and Tables II-III. Fig.3 visualizes the reduction of false alarms while Tables II-III show corresponding values of evaluation indexes DR, FAR, EFF. In more details, Tables II-III show that the faults are totally detected in the error range (DR = 100%) by the ADFC detector. In addition, applying the AFD scheme, the false alarm rate (FAR) is reduced from about 8.6% to about 1% and hence the efficiency (EFF) indexes increase to 99%.

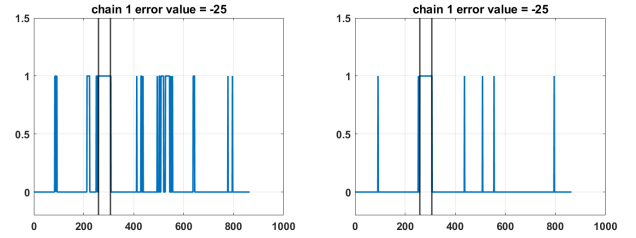

Fig. 3: Detection signals without (left) and with (right) AFD technique

Chain	DR (%)	FAR (%)	EFF (%)
1	100	8.6	91.4
2	100	8.6	91.4
3	100	8.7	91.3
4	100	8.7	91.3

TABLE II: Detection performance without AFD technique

Chain	DR (%)	FAR (%)	EFF (%)
1	100	0.7	99.3
2	100	1.0	99.0
3	100	1.0	99.0
4	100	1.0	99.0

TABLE III: Detection performance with AFD technique

To deal with the second question above, we measure the diagnosis performance by the *accuracy rate* A_r defined by

$$A_r = \sum_{k \in \mathcal{R}_j} \frac{\mathbb{I}(|\hat{b}_k - b_k| \leq r) \mathbb{I}(\hat{j} = j)}{|\mathcal{R}_j|} \times 100\%, \quad (4)$$

where $r > 0$ is a predetermined radius, \mathcal{R}_j is the error range corresponding to the fault chain j , $|\mathcal{R}_j|$ is the length of \mathcal{R}_j , \hat{b}_k and \hat{j} are estimates of actual values b_k and j , k is the time instant. So, A_r is the percentage of fault estimates in \mathcal{R}_j satisfying (3).

The simulation results related to the question (2) are given by Table IV. From the last row of the table, it is shown that all estimated chains are correct and all estimated fault values \hat{b}_k are away from the actual faults b_k at most a radius of $r = \Delta = 5$. The second row of the Table provides the accuracy percentage corresponding to the radius $r = \Delta/2$.

Chain		1	2	3	4
A_r (%)	$r = 5/2$	86	100	78	98
	$r = 5$	100	100	100	100

TABLE IV: The $A_r(\%)$ accuracy rate

Apart from the questions discussed above, the fact that AFD scheme using estimated fault to feed backwardly into $[\hat{x}_k|_k]$ increases the estimation performance of the OUBIKF as the results shown in Fig.4. In two figures in the left, the estimate intervals between two vertical black lines (the error range) deviate from the real states, even no longer contain these states and, in addition, the widths of these estimate intervals increase. In two figures in the right, the estimate intervals still track the real states well with reasonable widths.

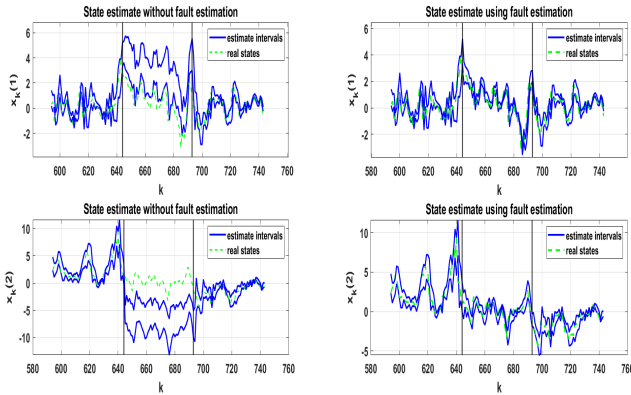

Fig. 4: Active fault diagnosis - State estimates without (left) and with (right) fault estimation feedback.

V. CONCLUSION

In this paper, an AFD scheme is developed for ADFC method. It can be seen as a diagnoser using auxiliary signals that allows to improve greatly the ADFC detector performance as well as FDI and FE of the proposed strategy.

The most relevant characteristic of the scheme is that auxiliary signals are not injected into the monitored system but provided only to the diagnoser. This is also the key difference of the scheme with other AFD methods. This helps to avoid additional disturbances due to auxiliary signals on the monitored system. In addition, auxiliary signals are designed off-line and only injected into the diagnoser once a detected signal ($\pi_k = 1$) is dispatched at a time instant k . Then, the generated signature matrix is analyzed to provide decisions

about the fault candidate without delay of any finite time (instant) interval in which the diagnoser waits reactions of the monitored system being injected. This implies that the developed scheme can provide an on-line fault diagnosis with no delay in time instant and with computation time depending only on the computer performance.

Another important characteristic of the scheme is the compensation for the actual fault effect to the diagnosis at the next iteration by using the estimated fault as a feedback to the diagnoser. It is important for the developed scheme because without it, the diagnosis performance of the scheme degrades severely. It may be also a good additional strategy for several existing AFD and state estimation methods.

REFERENCES

- [1] Q. H. Lu, S. Fergani, and C. Jauberthie, "A new scheme for fault detection based on optimal upper bounded interval kalman filter," *IFAC-PapersOnLine*, vol. 54, no. 7, pp. 292–297, 2021, 19th IFAC Symposium on System Identification SYSID 2021. [Online]. Available: <https://www.sciencedirect.com/science/article/pii/S2405896321011484>
- [2] R. V. Beard, "Failure accommodation in linear system through self-reorganization," PhD Thesis, Massachusetts Institute of Technology Dept. of Aeronautics and Astronautics, 1971. [Online]. Available: <http://hdl.handle.net/1721.1/16415>
- [3] H. L. Jones, "Failure accommodation in linear system through self-reorganization," PhD Thesis, Massachusetts Institute of Technology Dept. of Aeronautics and Astronautics, 1973. [Online]. Available: <http://hdl.handle.net/1721.1/16414>
- [4] R. Mehra and J. Peschon, "An innovations approach to fault detection and diagnosis in dynamic systems," *Automatica*, vol. 7, pp. 637–640, 1971.
- [5] J. Chen and R. J. Patton, *Robust Model-Based Fault Diagnosis for Dynamic Systems*, Springer science+business media New York ed., ser. The Kluwer International Series on Asian studies in Computer and Information Science. Kluwer Academic Publishers, 1999.
- [6] S. X. Ding, *Model-Based Fault Diagnosis Techniques*. Springer, 2013. [Online]. Available: <https://doi.org/10.1007/978-1-4471-4799-2>
- [7] S. L. Campbell and R. Nikoukhan, *Auxiliary Signal design for Failure Detection*. Princeton University Press, 41 William Street, Princeton, New Jersey, 08540, 2004.
- [8] H. Niemann, "Fault tolerant control based on active fault diagnosis," in *Proceedings of the 2005, American Control Conference, 2005.*, 2005, pp. 2224–2229 vol. 3. [Online]. Available: <https://doi.org/10.1109/ACC.2005.1470299>
- [9] H. Niemann and N. K. Poulsen, "Active fault diagnosis in closed-loop systems," *IFAC Proceedings Volumes*, vol. 38, no. 1, pp. 448–453, 2005, 16th IFAC World Congress. [Online]. Available: <https://doi.org/10.3182/20050703-6-CZ-1902.01877>
- [10] J. Stoustrup and H. Niemann, "Active fault diagnosis by controller modification," *International Journal of Systems Science*, vol. 41, 2010. [Online]. Available: <https://doi.org/10.1080/00207720903470197>
- [11] H. Niemann and N. K. Poulsen, "Active fault detection in MIMO systems," in *2014 American Control Conference, 2014*, pp. 1975–1980. [Online]. Available: <https://doi.org/10.1109/ACC.2014.6858817>
- [12] I. Puncocchar and J. Skach, "A survey of active fault diagnosis methods," *IFAC-PapersOnLine*, vol. 51, no. 24, pp. 1091–1098, 2018, 10th IFAC Symposium on Fault Detection, Supervision and Safety for Technical Processes SAFEPROCESS 2018. [Online]. Available: <https://doi.org/10.1016/j.ifacol.2018.09.726>
- [13] J. Tan, S. Oлару, M. M. Seron, and F. Xu, "Set-based guaranteed active fault diagnosis for lpv systems with unknown bounded uncertainties," *Automatica*, vol. 128, p. 109602, 2021. [Online]. Available: <https://doi.org/10.1016/j.automatica.2021.109602>
- [14] L. Jaulin, M. Kieffer, O. Didrit, and E. Walter, *Applied Interval Analysis, with Examples in Parameter and State Estimation, Robust Control and Robotics*. London: Springer-Verlag, 2001.
- [15] S. Fergani, "Robust multivariable control for vehicle dynamics," PhD Thesis, Grenoble INP, GIPSA-lab, Control System dpt., Grenoble, France, October 2014.