



HAL
open science

Modeling the End-to-End Energy Consumption of a Nation-Wide Smart Metering Infrastructure

Adrien Gougeon, François Lemerrier, Anne Blavette, Anne-Cécile Orgerie

► **To cite this version:**

Adrien Gougeon, François Lemerrier, Anne Blavette, Anne-Cécile Orgerie. Modeling the End-to-End Energy Consumption of a Nation-Wide Smart Metering Infrastructure. ISCC 2022 - IEEE Symposium on Computers and Communications, Jun 2022, Rhodes, Greece. pp.1-7, 10.1109/ISCC55528.2022.9912949 . hal-03666587

HAL Id: hal-03666587

<https://hal.science/hal-03666587v1>

Submitted on 12 May 2022

HAL is a multi-disciplinary open access archive for the deposit and dissemination of scientific research documents, whether they are published or not. The documents may come from teaching and research institutions in France or abroad, or from public or private research centers.

L'archive ouverte pluridisciplinaire **HAL**, est destinée au dépôt et à la diffusion de documents scientifiques de niveau recherche, publiés ou non, émanant des établissements d'enseignement et de recherche français ou étrangers, des laboratoires publics ou privés.

Modeling the End-to-End Energy Consumption of a Nation-Wide Smart Metering Infrastructure

Adrien Gougeon*, François Lemerrier*, Anne Blavette†, Anne-Cécile Orgerie*

*Univ. Rennes, Inria, CNRS, IRISA, Rennes, France, Email: firstname.lastname@irisa.fr

†Univ. Rennes, ENS Rennes, CNRS, SATIE lab, Rennes, France, Email: anne.blavette@ens-rennes.fr

Abstract—Several countries have deployed, or have started the deployment of a smart metering infrastructure in order to enable the Smart Grid. This infrastructure aims to provide new services to grid users and grid operators relying on several communication technologies. One of the goals of this infrastructure is to improve energy consumption, for instance by increasing the awareness of the users, or by enforcing energy management policies. Yet, this infrastructure also consumes energy. The objective of this work is to accurately characterize the energy consumption of each part of the smart metering infrastructure, at a nation-wide scale. We also explore several consumption scenarios highlighting the impact of legacy technologies on the energy consumption of the smart metering infrastructure.

I. INTRODUCTION

In order to achieve a climate neutral economy, a large-scale roll-out of smart meters is strongly encouraged worldwide and in particular in the European Union [1]. The objectives of this roll-out are multiple: (1) having a finer temporal granularity of consumption data for the consumers, grid operators and energy providers, in order to implement energy saving schemes, reduce the consumers energy bill, increase the consumption share from renewables and improve network planning, (2) allowing remote automated consumption data collection, (3) enabling remote adjustment of the contract power level, (4) providing two-way data transfer for maintenance and control. The first point underlines one of the main purposes of using a smart metering infrastructure: reducing the grid users energy consumption [2].

While smart metering aims at saving energy, it also induces additional energy consumption to power the ICT infrastructure which collects measurements from smart meters and presents them to end-users.

In this context, the purpose of this study is to provide an overview of the whole ICT architecture, model and evaluate the energy consumption of an entire smart metering infrastructure, at a nation-wide scale. This is a first step toward a full analysis of the gains and costs in terms of energy consumption related to smart grid metering. To obtain concrete results, we study the use-case of the deployment in France. Yet, the methodology that we propose in this paper can be applied to other countries. Given the recent deployment of the smart grid infrastructure and the expected lifetime of smart meters (around 30 years), this use case represents a good candidate to realistically assess the impact of smart metering in the next years. Our evaluation takes into account the end-to-end consumption, from the smart meter measuring the consumers individual consumption, to

the utility storing and processing the collected data. We also consider the energy cost of the communication networks involved in the system. This paper’s contributions can be summarized as follows:

- investigating the end-to-end architecture of advanced metering infrastructures (AMI) for Smart Grids
- proposing a complete modeling of the energy consumption of the ICT metering infrastructure of a large-scale electrical grid
- applying our model on the French use-case to evaluate the energy consumption of the smart metering infrastructure at a nation-wide scale.

The paper is organised as follows. Section II presents the state of the art. Section III provides details about the smart metering infrastructure. Section IV presents the consumption models. Section V deals with the evaluation of our models presenting the parameters we selected, the results obtained and some suggestions to tackle the issues unveiled by our energy model. Finally, Section VI concludes.

II. STATE OF THE ART

Studies on energy-efficiency of smart grid communication technologies mainly tackle optimization problems on routing protocols [3], energy harvesting from the smart-meter point-of-view [4] or data aggregation to reduce the data volume. The literature is rich on how to optimize the energy efficiency of this ICT system [5], for either actual deployment or envisioned optimized ones [6], but scarce on assessing its energy consumption. Preisel *et al.* accurately measured the electricity consumption of various smart meter devices [7]. These measurements are used by Malmodin *et al.* to estimate the gains and costs in terms of energy consumption of a large-scale smart metering infrastructure [8]. They outline the fact that previous small-case studies tend to be biased towards overly optimistic results, and that: “*the impact of the smart metering system itself, while being typically left out in most former studies reviewed, [...] may be significant in low and even medium reduction scenarios*”. Yet, their study only considers the smart meters themselves and not the overall ICT infrastructure required to collect and process the data produced by the smart meters. Ghasempour *et al.* present in [9] an energy consumption model of an Advanced Metering Infrastructure (AMI), proposing a new metric that takes into account the product of cost and energy to determine the adequate number of concentrators needed.

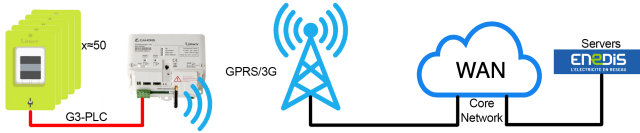

Fig. 1. Communication path from a smart meter cluster to the central utility in the French case.

Despite interesting results verified by simulation on the optimum number of concentrators, this study only consider a 100 km² area with a uniform distribution of the meters.

To the best of our knowledge, proposing an end-to-end energy model of a smart metering infrastructure has not been addressed in the literature. In this context, we propose to evaluate the energy consumption of an entire smart metering infrastructure, at a nation-wide scale.

III. SMART METERING ARCHITECTURE

Thirty-five million smart meters are deployed in France [10], scattered in clusters, each being connected to one of the 770,000 PLC (PowerLine Communication) concentrators [10]. Concentrators collect metering data, alarms and control data of smart meters once a day. They forward these data to a central utility using cellular communication to reach the closest relay antenna. The communication is then relayed using the WAN to the core Internet. Finally, the servers are connected to the Internet via wired communication as depicted in Figure 1.

A smart meter routine is composed of two tasks: collect local data, and communicate through PLC with its concentrator. Consequently, from an energy consumption perspective, each smart meter is either in idle state, when it does not communicate (either idle or collecting data) or active, when it communicates with its concentrator. The active state duration depends on the PLC technology considered, either G1-PLC [11] or G3-PLC [12], the latter being an evolution of the former and offering better performance with Orthogonal Frequency-Division Multiplexing (OFDM). PLC technologies are also heavily impacted by the quality of the network and by electromagnetic interference, increasing the number of re-transmissions and the overall communication time. Depending on the type of electrical network, some smart meters belong to small clusters with low network variability while the others belong to large clusters that are more prone to collisions. Collected data is forwarded each day, or on demand, by smart meters to the concentrator to which they are associated.

Concentrators are in charge of collecting data from smart meters, and forward aggregated data through the cellular network to the central utility. They must maintain connectivity with their smart meters at all times, either for contacting a specific smart meter on demand, or for being reachable by a smart meter triggering an alarm. As a consequence, concentrators are always active, and this state corresponds to a fixed power consumption. They also present an additional energy consumption, due to the cellular communication

network they employ to reach the core network. The cellular technology in use has evolved with time, formerly mainly based on GPRS, while most concentrators use 3G nowadays. Consequently, we consider that a majority of the concentrators has transitioned to 3G while the others still use GPRS.

The concentrators send data over the Internet using cellular networks which rely on Base Transceiver Stations (BTS) for GPRS communication, and on Node B for 3G communication. The energy consumption of cellular network devices is slightly impacted by data traffic [13], in consequence, the total consumption of the cellular network is close to the static consumption of all the devices. Hence, as Guegan *et al* presented in [14], we consider that the static consumption of network devices can be imputed to the users of said devices. The share of energy consumed is based on the duration and capacity usage in comparison to average load of the cellular network devices. Finally, as GPRS and 3G technologies paradigms are different, for instance a BTS provides time slots to a GPRS communication, while a Node B provides bandwidth for a 3G communication, we use two different ways to model the energy consumption of each technology.

Once the data transmitted by the concentrators reaches a relay antenna of the cellular network, it goes through the core network, passing through several network devices to reach its destination. Similarly to the cellular network and in accordance with [14], the share of the energy consumed due to concentrators traffic depends on the relative use of the network devices.

Finally, the transiting data reaches the central utility servers. The data is stored using the utility operator servers that are replicated for security and availability purposes. The overall energy consumption of the servers is considered, including, among others, the energy needed to cool the servers, using the PUE factor (Power Usage Effectiveness) of the data center. The number of servers depends on the user requests on the website, with a high variability of the requests rate, as often, and on the data flows from the concentrators.

The energy consumption models of the overall infrastructure detailed above are presented in the next section.

IV. NETWORK POWER MODELS

In the remainder of the paper, our models consider the energy consumption over a typical day.

A. Smart meters

The smart meters consumption highly depends on the cluster size (small or large) in which they are and on the PLC technology (G1 or G3) they rely on. Thus, four categories can be distinguished for the daily smart meters consumption:

$$E_{SM}^{smallG1} = N_{SM}^{small} \times R_{G1} \times [P_{SM}^{active} \times T_{active}^{small} \times F_{G1} + P_{SM}^{idle} \times (T_{day} - T_{active}^{small}) \times F_{G1}] \quad (1)$$

$$E_{SM}^{smallG3} = N_{SM}^{small} \times (1 - R_{G1}) \times [P_{SM}^{active} \times T_{active}^{small} + P_{SM}^{idle} \times (T_{day} - T_{active}^{small})] \quad (2)$$

$$E_{SM}^{largeG1} = N_{SM}^{large} \times R_{G1} \times [P_{SM}^{active} \times T_{active}^{large} \times F_{G1} + P_{SM}^{idle} \times (T_{day} - T_{active}^{large}) \times F_{G1}] \quad (3)$$

$$E_{SM}^{largeG3} = N_{SM}^{large} \times (1 - R_{G1}) \times [P_{SM}^{active} \times T_{active}^{small} + P_{SM}^{idle} \times (T_{day} - T_{active}^{large})] \quad (4)$$

where P_{SM}^{active} and P_{SM}^{idle} are the power consumption in active and idle state, respectively, T_{active}^{small} and T_{active}^{large} are the active time of smart meters in small and large clusters, respectively, N_{SM}^{small} and N_{SM}^{large} are the number of clusters, respectively, R_{G1} is the fraction of G1 smart meters in proportion to all smart meters in the infrastructure, F_{G1} is a factor increasing the active time due to the low data rate of G1-PLC, T_{day} is the duration of a day.

B. Concentrators

Concentrators' consumption depends on their static consumption and on the additional consumption induced by their communication over GPRS and 3G networks. As such, the concentrators daily energy consumption is divided into three categories: their static consumption, their consumption due to GPRS communication and the one due to 3G communication:

$$E_{CT}^{static} = P_{CT}^{static} \times T_{day} \times N_{CT} \quad (5)$$

$$E_{CT}^{GPRS} = N_{CT} \times R_{GPRS} \times P_{GPRS} \times \frac{DV_{CT}}{DR_{GPRS}} \quad (6)$$

$$E_{CT}^{3G} = N_{CT} \times (1 - R_{GPRS}) \times P_{3G} \times \frac{DV_{CT}}{DR_{3G}} \quad (7)$$

where P_{CT}^{static} is the static power consumption of a concentrator, N_{CT} is the number of concentrators, P_{GPRS} and P_{3G} are the power consumption delta when using GPRS or 3G communication, respectively, R_{GPRS} is the proportion of concentrators using GPRS, DV_{CT} is the data volume a concentrator sends each day, DR_{GPRS} and DR_{3G} are the GPRS and 3G data rate, respectively.

C. Cellular network

Data from concentrators transiting through the cellular network corresponds only to part of the traffic handled by GPRS and 3G network devices. We employ a proportional model to attribute the daily energy consumption induced by concentrators on the cellular infrastructure:

$$E_{GPRS} = \frac{P_{BTS} \times N_{CT}^{timeslots}}{N_{BTS}^{timeslots} \times Load_{BTS}} \times \frac{(DV_{CT} \times N_{CT} \times R_{GPRS})}{DR_{GPRS}} \quad (8)$$

$$E_{3G} = \frac{P_{NB} \times DR_{3G}}{DR_{NB} \times Load_{NB}} \times \frac{(DV_{CT} \times N_{CT} \times (1 - R_{GPRS}))}{DR_{3G}} \quad (9)$$

where P_{BTS} and P_{NB} are the power consumption of a BTS and a Node B, respectively, $N_{CT}^{timeslots}$ is the number of time slots used by a concentrator, $N_{BTS}^{timeslots}$ is the number of time slots on a BTS, B_{CT} is the cellular bandwidth usage of a concentrator, B_{NB} is the maximum bandwidth of a Node B, $Load_{BTS}$ and $Load_{NB}$ are the average load of a BTS and a Node B, respectively.

D. Core network

Similarly to the cellular network, data transiting through the core network relies on specific devices, such as switches and routers. Thus, we evaluate the consumption of the core network that can be imputed to their usage by the smart metering infrastructure using a model from [14]:

$$E_{static}^{device} = \frac{P_{static}^{device} \times B^{CT}}{B^{device} \times Load^{device}} \times T \quad (10)$$

$$E_{dynamic}^{device} = E_{byte}^{device} \times NbBytes + E_{pkt}^{device} \times NbPkts \quad (11)$$

where P_{static}^{device} is the power consumption of a core network device, B^{CT} is the bandwidth used by a concentrator, B^{device} is the bandwidth of a core network device, $Load^{device}$ is the average load of a core network device, E_{byte}^{device} and E_{pkt}^{device} are the energy consumed to transfer a byte and a packet, respectively, $NbBytes$ and $NbPkts$ are the number of bytes and packets to transfer, respectively.

E. Servers

Data storage and availability to the users has an energy cost through the usage of servers, whose daily energy consumption represents:

$$E_{servers} = N_{servers} \times N_{replicas} \times PUE \times P_{server} \times T_{day} \quad (12)$$

$$N_{servers} = \max(N_{servers}^{writing}, N_{servers}^{requests}) \quad (13)$$

$$N_{servers}^{writing} = \frac{Bandwidth}{DiskWritingSpeed} \quad (14)$$

$$N_{servers}^{requests} = \frac{Webrequests \times PeakFactor}{serverrequests} \quad (15)$$

where $N_{servers}$ is the number of servers, $N_{replicas}$ is the number of replicas of the servers, P_{server} is the power consumption of a server, $N_{servers}^{writing}$ is the number of servers required to store collected data, $N_{servers}^{requests}$ is the number of servers required to answer the web requests on the website, $Bandwidth$ is the bandwidth at which collected data arrive to the servers, $DiskWritingSpeed$ is the writing speed of a hard drive disk, $Webrequests$ is the number of web requests per seconds, $PeakFactor$ is a factor to reflect the variability at which web requests arrive, $serverrequests$ is the number of web requests per second a server can handle. We determine the minimum number of servers needed by considering the number of servers required to respond to the peak of requests from web users and the servers required to store all the data from the meters.

V. EVALUATION

We evaluate the daily consumption of the smart metering infrastructure using the consumption models detailed in the previous section. These models require coherent instantiation of their variables. We first detail the parameter values taken from literature, and then presents the obtained results. These parameters can be modified freely on the web interface we developed for this work¹.

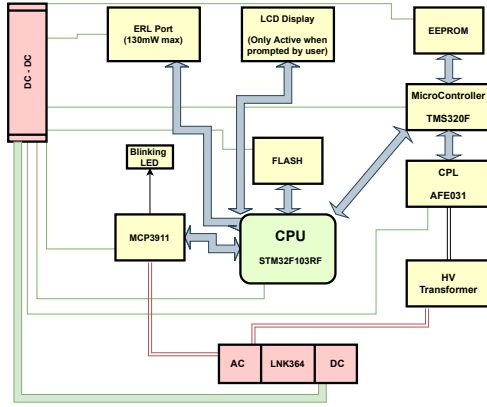

Fig. 2. Simplified Electronic Architecture of a Linky Smart meter.

A. Parameters estimation

1) *Smart meters*: The power consumption of a smart meter depends on its current state. A smart meter idle power is evaluated at around 0.2W [15], [16]. Its active power, when actively communicating through PLC, is highly variable and depends on the impedance of the line to which it is connected. This active power is evaluated around 1W [15], [16]. To assess the consumption of a smart meter, we analyzed the most important electronic components of a French Linky meter, as shown in Figure 2. Concerning the proportion of G1-based meters, this technology was exclusively deployed until 2017 with a total of 7 million smart meters deployed at this moment [17]. Afterward and up to the present day, only G3-based meters were deployed. Hence, around 20% of the smart meters still use the G1 PLC technology.

The active time of a smart meter during a typical day can greatly varies from one meter to another. It depends on the data the smart meter has to transmit each day to its concentrator and also on the maintenance operations of the concentrator. This active time is heavily impacted by the PLC technology in use, as G1 data rate is around 14 times lower than G3 [11], [12]. The active time depends also on the number of smart meters in the same cluster. The PLC technology suffers indeed severely from collision when there are multiple communications on the same channel. To determine the ratio of smart meters in large clusters, we use population statistics, assuming that 80% of the French population is located in dense urban areas [18], and the concentrators are expected to be spread evenly to ensure a full coverage of the territory, inducing large clusters in urban environment and small clusters in rural environment. Consequently, among the 35 million smart meters deployed [10], 28 million are in large clusters, and 7 million in small clusters. The active time in small and large clusters is assumed to be in the order of minutes and in the order of hours, respectively.

2) *Concentrators*: Concentrators must maintain connectivity with their cluster and are consequently always in active

state. We assume that their static consumption is around 15W. In addition to their static consumption, we also take into account the energy consumed by cellular communication. This consumption depends on the additional power consumption during communication, estimated at around 1.4W for GPRS [19] and 2.1W for 3G [20]. It also depends on the duration of the communication. This duration depends on the data volume to transmit, assumed to be 150kB per concentrator on average, considering that concentrators aggregate on average data from 50 smart meters, each one producing 3kB of data each day. The duration also depends on the upload data rate of the cellular technologies. The GPRS data rate considered is 24kbps [21] with the coding scheme CS-2 and using two time slots, while we consider a data rate of 350kbps for 3G [22]. We expect that the transition from GPRS to 3G followed the transition from G1 to G3, with the production of more modern devices. Thus, 20% of the concentrators are expected to use GPRS while the rest uses 3G.

Finally, there are 770,000 concentrators deployed in the country [10].

3) *Cellular network*: A Base Transceiver Station (BTS) site, including an antenna and the necessary pieces of equipment such as batteries and lighting, is assumed to have an average power consumption of 1,430W [13]. We consider 3 transceivers per BTS, with 8 time slots each [23]. The average load of a BTS is assumed to be similar to a Node B and equal to approximately 30% [23], [24]. A Node B has an average power consumption of 1,450W [13] and an available bandwidth of 1,361kbps [24].

4) *Core network*: According to [14], a typical data transfer has 9 hops to reach the core network, going through 8 edge switches and 1 core router. Network devices parameters are listed in Table I.

5) *Servers*: According to Enedis, the website offering users their detailed consumption has on average 540,000 visits per month, with on average 2.38 webpages viewed per visit. We assume a conservative client-server architecture where the server can handle 200 concurrent requests per second, and the peak factor in web requests is set to 10 [25]. The writing speed of the server's HDD are set to 150MBps. A storage oriented server has an estimated power consumption of 108W [26] and the PUE of a small scale cloud is estimated at 1.7 [27]. Finally, the number of replicas is set to 3.

TABLE I
CORE NETWORK DEVICES MODEL PARAMETERS [14].

Parameter	Edge switch	Core router
p_{device}^{static}	150 W	555 W
$AggregateBandwidth^{device}$	48 Gbps	48 Gbps
$LinkUtilization^{device}$	25%	25%
p_{byte}^{device}	3.4 nJ	3.4 nJ
p_{pkt}^{device}	192 nJ	192 nJ

¹ Available here: <https://smart-grid-network.herokuapp.com/>

B. Results

Figure 3 presents the overall consumption of the smart metering infrastructure using values defined in Table I and Table II. The overall consumption of the smart metering infrastructure is estimated at 405MWh per day. If we assume a static power of 1W per meter for the previous generation of meters, it would represent 840MWh per day. In this case, the smart metering infrastructure would consume less than half of the consumption of the previous generation meters.

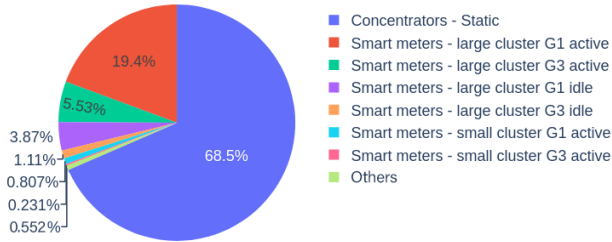

Fig. 3. Daily energy consumption of the smart metering infrastructure.

TABLE II
MODELS PARAMETERS

Parameter	Value	Source
$N_{SM}^{small}, N_{SM}^{large}$	7M, 28M	[18]
$P_{SM}^{idle}, P_{SM}^{active}$	0.2W, 1W	[15], [16]
$T_{small}^{active}, T_{large}^{active}$	600s, 3600s	see Section V-A1
R_{G1}, R_{GPRS}	0.2, 0.2	[17]
F_{G1}	14	[11], [12]
N_{CT}	770,000	[10]
P_{CT}^{static}	15W	see Section V-A2
P_{GPRS}	1.4W	[19]
P_{3G}	2.1W	[20]
DV_{CT}	150kB	see Section V-A2
DR_{GPRS}	24kbps	[21]
DR_{3G}	350kbps	[28]
P_{BTS}	1,430W	[13]
$N_{CT}^{timeslots}$	2	see Section V-A2
$N_{BTS}^{timeslots}$	24	[23]
$Load_{BTS}, Load_{NB}$	0.3	[24], [23]
DR_{NB}	1,361kbps	[24]
P_{NB}	1,450W	[13]
$N_{replicas}$	3	see Section V-A5
P_{UE}	1.7	[27]
P_{server}	108W	[26]
$DiskWritingSpeed$	150MBps	see Section V-A5
$WebRequests$	1.5M/month	see Section V-A5
$PeakFactor$	10	see Section V-A5
$CPU_{requests}$	200/s	see Section V-A5

The concentrators energy consumption represents most of the smart metering infrastructure overall consumption (68%). The additional energy consumption by the concentrators during cellular communication is negligible and accounts for only 0.002% of the concentrators consumption. This is due to their high static power consumption, and to the low amount of data to transfer, inducing a consumption of only 70J per day and per concentrator using GPRS, and 7J per day and per concentrator using 3G.

The smart meters account for 31% of the total consumption, with 96% of their consumption due to large clusters.

TABLE III
CASES EXPLORED.

Case	Specificity
Default	Default case
G1-only	Only G1 smart meters
G3-only	Only G3 smart meters
GPRS-only	Only GPRS communication
3G-only	Only 3G communication
SG-services	Future SG services

It means that while 20% of the smart meters are in small clusters, they only account for 4% of the consumption of the smart meters. This result highlights a strong impact of PLC in large clusters representative of a dense urban environment in our model. We also observe the influence of the lower data rate of G1. Large G1 clusters account for 62% of the consumption of the smart meters while large G3 clusters only account for 18%, although there are 4 times more smart meters in large G3 clusters than in large G1 clusters.

The energy consumed by the cellular network is low in comparison to the concentrators and the smart meters with, respectively, 0.21% and 0.18% of the total energy consumed due to the 3G and GPRS network.

Finally, the energy consumed by the servers and the core network is negligible, with only 0.003% of the total energy consumed.

Using our energy model, we also explored several other cases, as listed in Table III. The corresponding results are shown in Figure 4.

1) *G1-only and G3-only*: These cases highlight the interest of newer PLC technologies, improving data rate and drastically reducing the active time of smart meters. We see with the G1-only case that using the G1 technology exclusively would have almost doubled the energy consumed by the infrastructure. On the other hand, upgrading the remaining 20% of G1 smart meters to G3 would reduce the energy consumed by smart meters by 91MWh (72% less energy consumed by the smart meters, 22% of the total).

2) *GPRS-only and 3G-only*: These cases investigate the interest of switching from the old GPRS technology to 3G. Sticking to GPRS would have increased the energy consumed by 2.7MWh according to our model. On the other hand, upgrading the current 20% concentrators from GPRS to 3G would reduce the energy consumed by 0.7MWh. This represents a reduction of 58% in the energy consumption by the cellular network, but this translates into a reduction of only 0.2% in the overall energy consumption. Hence, although the 3G technology consumes indubitably less energy than GPRS for this given traffic, in comparison to the considerable energy consumed by smart meters and concentrators, the interest of switching from GPRS to 3G is low from an energy consumption point of view, especially when considering the gray energy required to replace the GPRS smart meters. Furthermore, the financial cost may be higher.

3) *Energy reduction*: Using the end-to-end energy model, one can also explore the possibility of using modified smart

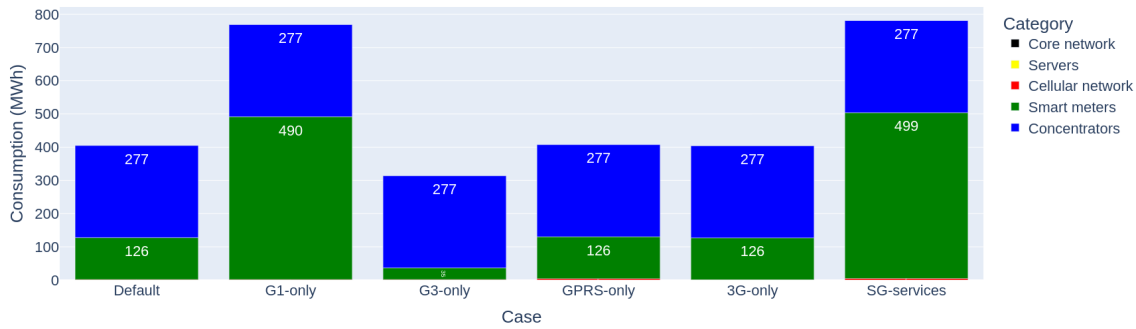

Fig. 4. Exploration of various consumption cases of the smart metering infrastructure for one day.

meters able to directly communicate through 3G. Such smart meters remove the need for concentrators, as they could directly send their data to the central utility using cellular networks. The increase in power consumption while using the 3G module is the same as with a concentrator, 2.1W. A smart meter now consumes 2.3W while active (previously 1W), but with a datarate of 350kbps. At such a datarate less than 1s is necessary to send a smart meter daily payload. The energy consumed by the cellular network, the core and the servers is the same as the total data volume to transfer remains similar. This case results in a total daily energy consumption of 169MWh, 2.4 times less than the current energy consumption. Yet, the mobile monthly subscription with this option may be prohibitive if fully supported by the grid operator.

Results show the large energy consumption of the concentrators and the smart meters, accounting for respectively 68% and 31% of the energy consumed, making the consumption from the cellular network, the core network and the servers negligible in comparison. They also show that using newer technologies effectively reduces the energy consumed. It is especially visible with the transition from G1 to G3 smart meters, saving 74% of the energy consumed of the smart meters in comparison to the case where the transition did not happen.

C. Discussion

Several benefits are expected from a smart metering infrastructure. From the user point of view, the main benefit consists in the possibility to have energy consumption data at a smaller temporal resolution. This facilitates changes in energy usage behavior. However, the metering granularity and the important delay before the availability of the data online — every day — may degrade this benefit to a non-negligible extent. From the grid operator point of view, the main benefit is to improve its network planning, control and maintenance, while the energy provider may provide more dynamic energy price schemes to its clients. Nevertheless, the still coarse metering granularity may not be sufficient to get the full benefit of the smart metering infrastructure. The communication technologies are largely limiting the capabilities of the infrastructure. First, PLC is not adapted to transfer data at a high granularity. Secondly, higher

granularity would increase the data volume transmitted and the GPRS network could become another bottleneck due to its low data rate.

The smart metering infrastructure has been imagined, developed, and deployed with the idea of a highly communicating smart grid. The role of smart meters, in the long term, would consist not only to collect consumption data but to introduce dynamic, and possibly real-time, energy management mechanisms, either through indirect or direct remote control of smart devices inside each equipped home.

Such features would drastically increase the smart meters active time, and therefore their energy consumption. To explore the energy impact of such new features on the infrastructure, we defined a case (SG-services on Figure 4) where smart meters are active for 30 minutes and 12 hours in small and large clusters respectively. In this case, the energy consumed by smart meters is multiplied by 4, and the total consumption by 1.9, slightly exceeding the G1-only case. Yet, this coarse-grain analysis do not guarantee that such a data traffic, corresponding to about ten data gathering per day, would be feasible in all large clusters because of a high potential of collisions.

Based on the observations presented in this study, some solutions can be considered to reduce the energy consumption of the smart metering infrastructure. The main insight of this work is that concentrators and smart meters account for more than 99% of the infrastructure consumption. Thus, a first option consists in extensively using a low power state, or sleep mode, for concentrators and smart meters. Such sleeping mechanisms have been studied for PLC networks [29] and show that the proposed sleeping strategy performance highly depends on the delay and availability of the nodes. In this sense, the current PLC routing policy requires nodes to be available at all times, which may thus need to be adapted. In addition, maintaining the connectivity between concentrators and smart meters, combined with channel congestion, induces an increase in active time, especially in dense urban areas. In that sense, another option consists in shifting from PLC communication to cellular or long range wireless communication in areas with sufficient coverage. This solution reduces the active time of concentrators and smart meters as it is less subject to channel congestion and provides a significant increase in datarate in comparison to

PLC communication.

In addition, long range wireless communication would allow to manage more smart meters per concentrators, at least in some areas, or even allow direct connectivity between smart meters and a central utility. Thus, a significant amount of concentrators could be removed from the smart metering infrastructure, inducing a significant reduction in energy consumption. Recent studies have shown the suitability of such long range wireless communication in a smart grid context, as presented in [30]. However, shifting from one communication technology to another implies a replacement of the current infrastructure, thus inducing gray energy consumption, in addition to installation costs for the grid operator. Further analyses are necessary to evaluate the short and long term benefits of this potential communication technology shift.

VI. CONCLUSION

In this work, we evaluate the end-to-end energy consumption of a smart metering infrastructure at a nation-wide scale. We propose an energy consumption model for each part of the infrastructure. The instantiation of the models parameters is a tough task as data in this domain is scarce. For this reason, we evaluate the daily energy consumption of the infrastructure using the most coherent values found in literature. We also propose an interface that allows the reader to explore our models with its own set of parameters.

For a scenario where data from smart meters are collected once a day, the results show that concentrators and smart meters account for respectively 68% and 31% of the energy consumed, making cellular network, core network and servers' consumption negligible in comparison. Our study also highlight the effectiveness of the newer generation (G3-PLC) in reducing the energy consumption. Indeed, G3-PLC saves 74% of the energy consumed by the G1-PLC smart meters employed in the first phase of smart grid deployment.

These technologies allow the French smart metering program to meet the requirements of an Advanced Metering Infrastructure service, i.e. satisfying 99.99% of the reading rates. However, the granularity offered for measurement purposes, and potentially for control purposes, remains coarse, which may restrain the benefits for energy providers, grid operators and consumers. Moreover, such an improvement in the granularity may be limited by the current infrastructure. These issues may incite smart grid actors to switch to different communication technologies and rethink the whole smart metering infrastructure.

ACKNOWLEDGMENT

This project has received financial support from the CNRS Momentum project RI/RE through the MITI interdisciplinary programs

REFERENCES

- [1] Tractebel, "Benchmarking smart metering deployment in the EU-28," European Commission, Tech. Rep., 2019.
- [2] N. Mogles *et al.*, "How smart do smart meters need to be?" *Building and Environment*, vol. 125, pp. 439–450, 2017.
- [3] R. Ullah, Y. Faheem, and B.-S. Kim, "Energy and congestion-aware routing metric for smart grid ami networks in smart city," *IEEE Access*, vol. 5, pp. 13 799–13 810, 2017.
- [4] S. Bera, S. Misra, and M. S. Obaidat, "Energy-efficient smart metering for green smart grid communication," in *2014 IEEE Global Communications Conference*, 2014, pp. 2466–2471.
- [5] M. Erol-Kantarci and H. T. Mouftah, "Energy-Efficient Information and Communication Infrastructures in the Smart Grid: A Survey on Interactions and Open Issues," *IEEE Communications Surveys & Tutorials*, vol. 17, no. 1, pp. 179–197, 2015.
- [6] F. Uddin, "Energy-aware optimal data aggregation in smart grid wireless communication networks," *IEEE Trans. on Green Communications and Networking*, vol. 1, no. 3, pp. 358–371, 2017.
- [7] M. Preisel, A. Diaz, and W. Wimmer, "Energy Consumption of Smart Meters," in *Int. Conf. on ICT for Sustainability*, 2013.
- [8] J. Malmodin and V. Coroama, "Assessing ICT's enabling effect through case study extrapolation — The example of smart metering," in *Electronics Goes Green*, 2016.
- [9] A. Ghasempour and J. H. Gunther, "Finding the optimal number of aggregators in machine-to-machine advanced metering infrastructure architecture of smart grid based on cost, delay, and energy consumption," in *IEEE Ann. Consumer Comm. Netw. Conf.*, 2016, pp. 960–963.
- [10] Enedis, "Programme de R&D et d'Innovation d'Enedis," report, 2019.
- [11] IEC, "Distribution automation using distribution line carrier systems," International Electrotechnical Commission, Standard, 2004.
- [12] ITU, "Narrowband orthogonal frequency division multiplexing power line communication transceivers for G3-PLC networks," Telecommunication Standardization Sector of ITU, Standard, 08 2017.
- [13] O. Arnold, F. Richter, G. Fettweis, and O. Blume, "Power Consumption Modeling of Different Base Station Types in Heterogeneous Cellular Networks," in *ICT Mobile Summit*, 2010.
- [14] L. Guegan and A.-C. Orgerie, "Estimating the End-to-End Energy Consumption of Low-Bandwidth IoT Applications for WiFi Devices," in *IEEE Int. Conf. on Cloud Comp. Technology and Science*, 2019.
- [15] *Powerline Communications Analog Front-End*, Texas Instr., 2011.
- [16] *Powerline Communications Analog Front-End*, Texas Instrument, 2010, rev.E. [Online]. Available: <https://www.ti.com/lit/gpn/afe031>
- [17] Enedis, "Plus de 7 millions de familles équipées d'un compteur Linky, et alors ?," Enedis press kit, 2017.
- [18] V. Costemalle, "Toujours plus d'habitants dans les unités urbaines," INSEE, Tech. Rep., 2020.
- [19] *AirPrime HL6528 Embedded Module*, Sierra Wireless, 2019, rev. 15.
- [20] *AirPrime HL8518, HL8528 and HL8529 Embedded Modules*, Sierra Wireless, 2015, rev. 2.1.
- [21] B. Pfitzinger, T. Baumann, A. Emde, T. Gründer, T. Jestädt, and D. Macos, "Network-Wide Measurement of GPRS Bandwidth and Latency," in *Int. Conf. on System Sciences*, 2019.
- [22] T. Anwar, Lim, and W. Li, "Performance Analysis of 3G Communication Network," *ITB Journal of ICT*, vol. 2, 2008.
- [23] L. Jukka and M. Matti, *Radio Interface System Planning for GSM/GPRS/UMTS*. Springer, 2002.
- [24] Y. H. Chen, Y. C. Wang, C. L. Lai, and H. C. H. Rao, "Precise Estimation of WCDMA Downlink Pole Capacity in Multipath Propagation Channel by Monte Carlo Method," in *IEEE VTC-Spring*, 2007.
- [25] A. Prasad, D. Koll, J. Iglesias, J. Aroca, V. Hilt, and X. Fu, "Optimal Resource Configuration of Complex Services in the Cloud," in *IEEE/ACM Int. Symp. on Cluster, Cloud and Grid Computing*, 2017.
- [26] T. Inoue, A. Aikebaier, T. Enokido, and M. Takizawa, "Power consumption and processing models of servers in computation and storage based applications," *Mathematical and Computer Modelling*, vol. 58, no. 5, pp. 1475–1488, 2013.
- [27] Y. Li, A.-C. Orgerie, I. Rodero, B. L. Amersho, M. Parashar, and J.-M. Menaud, "End-to-end energy models for Edge Cloud-based IoT platforms: Application to data stream analysis in IoT," *Future Generation Computer Systems*, vol. 87, pp. 667–678, 2018.
- [28] 3GPP, "Group Services and System Aspects; Services and service capabilities," 3rd Generation Partnership Project (3GPP), Technical Specification (TS) 22.105, 2020, version 16.0.0.
- [29] S.-G. Yoon, "Performance analysis of power saving strategies for power line communications," in *IEEE Int. Conf. on Smart Grid Communications (SmartGridComm)*, 2017, pp. 314–319.
- [30] J. L. Gallardo, M. A. Ahmed, and N. Jara, "Lora iot-based architecture for advanced metering infrastructure in residential smart grid," *IEEE Access*, vol. 9, pp. 124 295–124 312, 2021.