



HAL
open science

Cerebellar control of saccades by the size of the active population in the caudal fastigial nucleus

Laurent Goffart, Julie Quinet, Clara Burrelly

► **To cite this version:**

Laurent Goffart, Julie Quinet, Clara Burrelly. Cerebellar control of saccades by the size of the active population in the caudal fastigial nucleus. Society for Neuroscience Meeting, Nov 2017, Washington DC, United States. hal-03654905

HAL Id: hal-03654905

<https://hal.science/hal-03654905v1>

Submitted on 29 Apr 2022

HAL is a multi-disciplinary open access archive for the deposit and dissemination of scientific research documents, whether they are published or not. The documents may come from teaching and research institutions in France or abroad, or from public or private research centers.

L'archive ouverte pluridisciplinaire **HAL**, est destinée au dépôt et à la diffusion de documents scientifiques de niveau recherche, publiés ou non, émanant des établissements d'enseignement et de recherche français ou étrangers, des laboratoires publics ou privés.

Laurent Goffart, Julie Quinet* & Clara Burrelly

Institut de Neurosciences de la Timone, CNRS & Aix-Marseille Université, Marseille, France

* : new address : Dept of Ophthalmology, University of Alabama, Birmingham, AL, USA

Introduction

The caudal fastigial nucleus (CFN) is critical for generating accurate saccades toward a visual target. Its pharmacological inactivation alters the amplitude of their horizontal component: it is hypermetric for ipsilesional saccades and hypometric for contralesional ones. A recent study reported that "ipsilesional saccades showed more endpoint variability than did normal saccades" and that the "inactivation effects on saccade noise are explained by a decrease of the feedback gain and an increase of planning and/or signal dependent motor noise" (Eggert et al., 2016). In the framework of a control of saccade amplitude by negative feedback, the hypermetria of the horizontal component of ipsilesional saccades can indeed be explained by an underestimation of the current eye displacement. However, instead of adding a notion which is rather neurophysiologically undetermined ("noise"), we propose that the endpoint variability actually reflects the size of the active population in the CFN. This conjecture derives from the results of Quinet & Goffart (2015) who showed that the size of saccades evoked by electrical microstimulation in the fastigial nucleus increases with larger current.

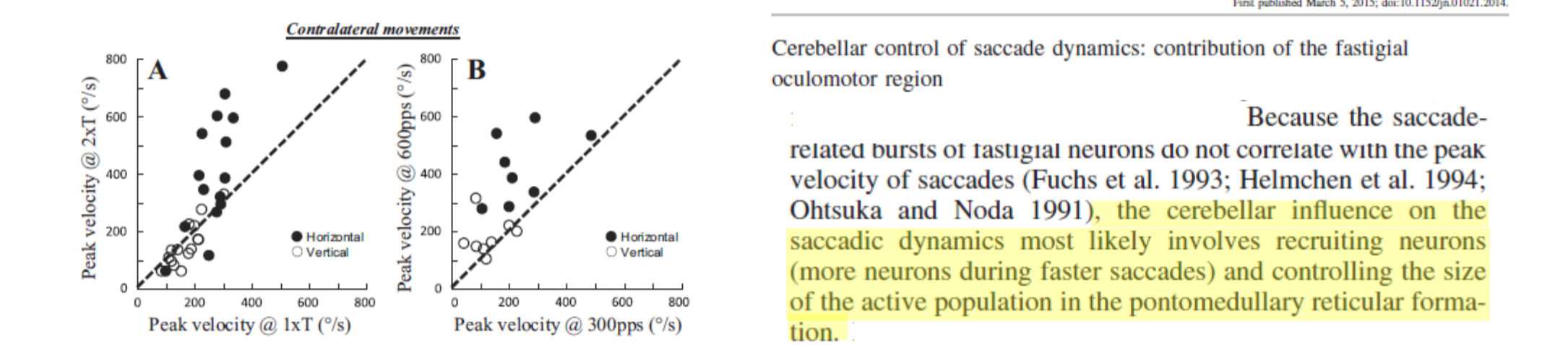

According to this hypothesis, if an injection of muscimol is made not exactly centered in the fastigial oculomotor region, the number of saccade-related neurons which are inactivated by the pharmacological agent should increase as it diffuses, resulting in a time-varying dysmetria. Moreover, this effect of diffusion should not be restricted to the generation of ipsilesional saccades, but should concern also the generation of contralesional ones. We show examples of inactivation experiments performed in the head-restrained monkey where the magnitude of dysmetria does not change with time and others where it increased. Depending upon the experiment, this time-varying effect affects either ipsilesional or contralesional saccades. Thus, the so-called "noise" inferred from the variability of endpoints after CFN inactivation seems to result from an increase of the number of neurons which are silenced by the pharmacological agent (muscimol).

Conclusion

Both cFN contribute to accelerate **and** decelerate the horizontal component of any saccade. The possibility to independently alter the horizontal component of ipsilesional or contralesional saccades suggests independent output channels from the CFN to the saccade-related premotor neurons. The **number** of active neurons in **both** cFN matters in the regulation of the dynamics of the horizontal component of saccades (Goffart et al. 2003). It participates to its dynamics by recruiting the appropriate number of premotor burst neurons, excitatory and inhibitory. The late burst emitted by some neurons in the ipsilateral cFN (Ohtsuka & Noda 1991; Fuchs et al. 1993) is neither "a brake" but the signature of a later **recruitment**.

Becker W, Jürgens R. Human oblique saccades: quantitative analysis of the relation between horizontal and vertical components. *Vision Res* 30: 893-920, 1990.
Eggert T, Robinson FR, Straube A. Modeling inter-trial variability of saccade trajectories: Effects of lesions of the oculomotor part of the fastigial nucleus. *PLoS Comp Biol* 12, 2016.
Fuchs AF, Robinson FR, Straube A. Role of the caudal fastigial nucleus in saccade generation. I. Neuronal discharge patterns. *J Neurophysiol* 70: 1712-1740, 1993.
Goffart L, Chen LL, Sparks DL. Saccade dysmetria during functional perturbation of the caudal fastigial nucleus in the monkey. *Ann NY Acad Sci* 1004: 220-228, 2003.
Ohtsuka K, Noda K. Saccadic burst neurons in the oculomotor region of the fastigial nucleus of macaque monkeys. *J Neurophysiol* 65: 1422-1434, 1991.
Quinet J, Goffart L. Cerebellar control of saccade dynamics: contribution of the fastigial oculomotor region. *J Neurophysiol* 113: 3323-3336, 2015.

Support

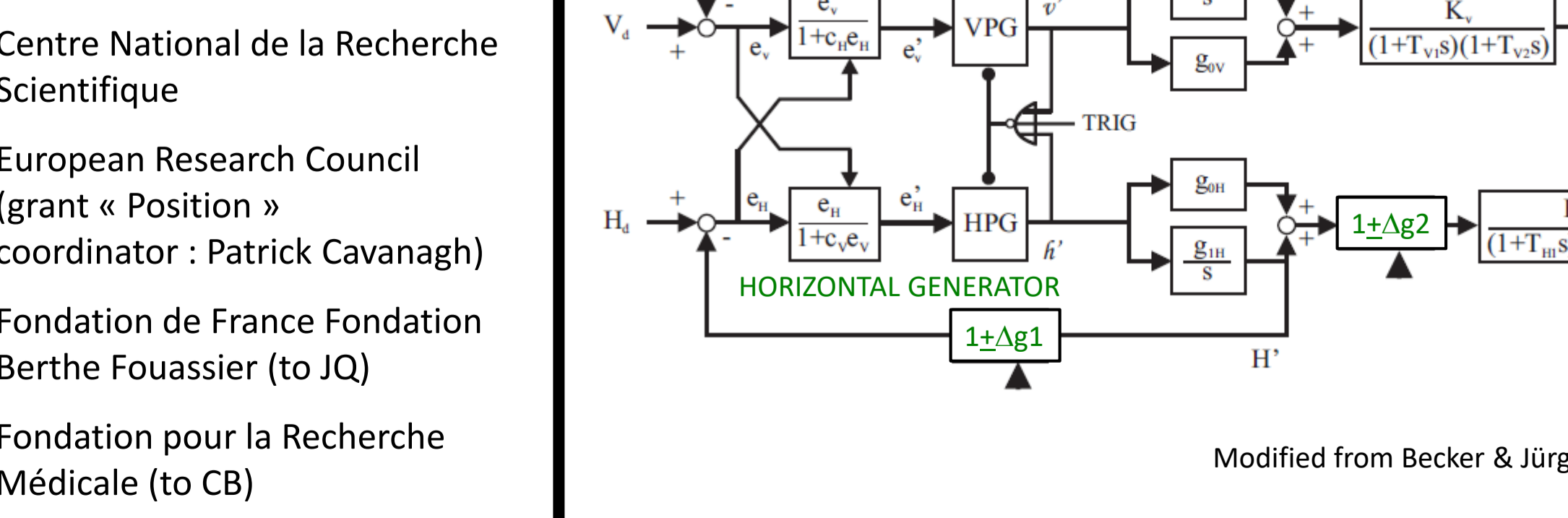

CONTRALESIONAL OBLIQUE SACCADES :
cFN inactivation primarily reduces the horizontal amplitude of contralesional oblique saccades. This hypometria is associated with a reduction of horizontal peak velocity. Changes in the duration of both components can be observed and they are correlated when they happen.

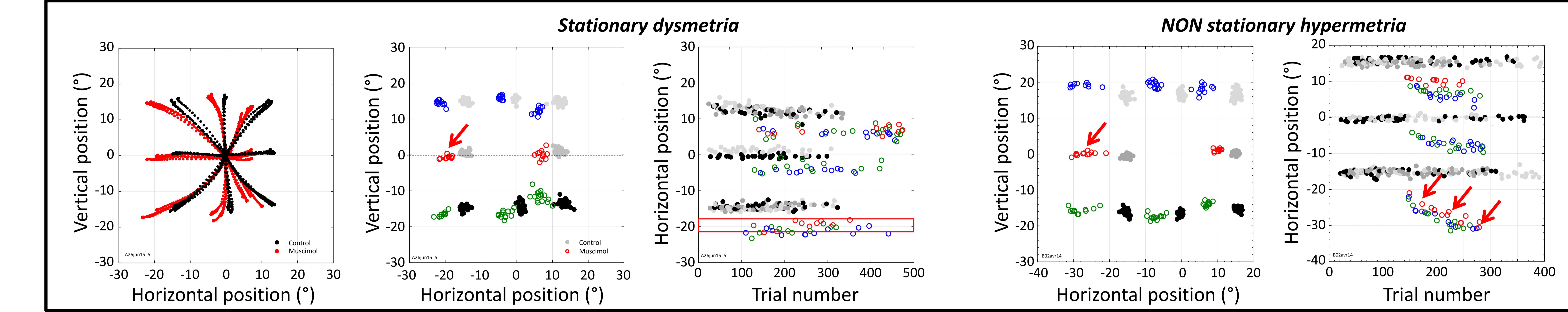

Methods

Four rhesus monkeys were used in this study. The movements of one eye were recorded with the scleral search coil in magnetic field technique. The saccades were initiated from a fixation target located straight ahead that the monkeys had to fixate for a variable interval (750 – 1500 by 250ms). Two hundred milliseconds after the disappearance of the central target (gap paradigm), a transient target (duration=100ms) appeared in the peripheral visual field (horizontal and vertical eccentricity of 0, 8 or 16°). The monkeys' task was to look at the location where the target was flashed. The target location varied pseudo-randomly between the trials. A series of (3-4) experiments were performed before each inactivation experiment in order to estimate the control performance. A total of 25 injections of muscimol were made locally in the cFN. The injections were made after the saccade-related regions were identified and localized using standard electrophysiological techniques (unit recording and microstimulation).

