



**HAL**  
open science

## Predictor-based control of time-delay systems: a survey

Yang Deng, Vincent Léchappé, Emmanuel Moulay, Zhang Chen, Bin Liang,  
Franck Plestan, Qing-Long Han

► **To cite this version:**

Yang Deng, Vincent Léchappé, Emmanuel Moulay, Zhang Chen, Bin Liang, et al.. Predictor-based control of time-delay systems: a survey. *International Journal of Systems Science*, 2022, 53 (12), pp.2496-2534. 10.1080/00207721.2022.2056654 . hal-03644248

**HAL Id: hal-03644248**

**<https://hal.science/hal-03644248v1>**

Submitted on 19 Apr 2022

**HAL** is a multi-disciplinary open access archive for the deposit and dissemination of scientific research documents, whether they are published or not. The documents may come from teaching and research institutions in France or abroad, or from public or private research centers.

L'archive ouverte pluridisciplinaire **HAL**, est destinée au dépôt et à la diffusion de documents scientifiques de niveau recherche, publiés ou non, émanant des établissements d'enseignement et de recherche français ou étrangers, des laboratoires publics ou privés.

## Predictor-based control of time-delay systems: A survey

Yang Deng<sup>a</sup>, Vincent Léchappé<sup>b\*</sup>, Emmanuel Moulay<sup>c</sup>, Zhang Chen<sup>a</sup>, Bin Liang<sup>a</sup>, Franck Plestan<sup>d</sup> and Qing-Long Han<sup>e</sup>.

<sup>a</sup> Department of Automation, Tsinghua University, Haidian, Beijing, 100084, China;

<sup>b\*</sup> Univ Lyon, INSA Lyon, Université Claude Bernard Lyon 1, Ecole Centrale de Lyon, CNRS, Ampère, UMR5005, 69621 Villeurbanne, France;

<sup>c</sup> XLIM (UMR CNRS 7252), Université de Poitiers, 11 bd Marie et Pierre Curie, 86073 Poitiers Cedex 9, France;

<sup>d</sup> Nantes Université, École Centrale Nantes, CNRS, LS2N, UMR 6004, F-44000 Nantes, France;

<sup>e</sup> School of Science, Computing and Engineering Technologies, Swinburne University of Technology, Melbourne, VIC 3122, Australia.

### ARTICLE HISTORY

Compiled March 20, 2022

### ABSTRACT

With the developments of wireless data communication and network technology, time-delays are widely found in nowadays' control systems, e.g. networked control systems, mobile robot systems, and multi-agent systems. Predictor-based control is an effective method dealing with long time-delays because it can generally lead to a delay-free closed-loop system by introducing a prediction for future states. Recently, various predictor-based control methods have been developed for numerous control systems subject to different time-delays, which motivates this survey. This paper presents a comprehensive review of the up-to-date results on the predictor-based control of time-delay systems. Firstly, the ordinary differential equation-based approaches for designing and analysing predictor-based controllers are summarised. Secondly, one reports an alternative method of predictor-based control, in which the systems/controllers are understood in the sense of partial differential equations. Next, several integration-free predictor-based controllers are introduced: by abandoning the infinite-dimensional integral terms, the control laws become easier to realise in practice. Hereafter, the paper discusses the real-time implementations and the practical applications of predictor-based control methods to several particular control systems. Finally, this paper suggests some new trends of predictor-based control for future research.

### KEYWORDS

Time-delay systems, predictor-based control, networked control systems, multi-agent systems, wireless robotic systems.

---

Contact Yang Deng. Email: [dengyang@mail.tsinghua.edu.cn](mailto:dengyang@mail.tsinghua.edu.cn)

Contact Vincent Léchappé. Email: [vincent.lechappe@insa-lyon.fr](mailto:vincent.lechappe@insa-lyon.fr)

Contact Emmanuel Moulay. Email: [emmanuel.moulay@univ-poitiers.fr](mailto:emmanuel.moulay@univ-poitiers.fr)

Contact Zhang Chen. Email: [cz.da@tsinghua.edu.cn](mailto:cz.da@tsinghua.edu.cn)

Contact Bin Liang. Email: [liangbin@tsinghua.edu.cn](mailto:liangbin@tsinghua.edu.cn)

Contact Franck Plestan. Email: [franck.plestan@ec-nantes.fr](mailto:franck.plestan@ec-nantes.fr)

Contact Qing-Long Han. Email: [qhan@swin.edu.au](mailto:qhan@swin.edu.au)

## 1. Introduction

This section lays out the general introduction of this survey, including the main purposes, the benefits, and several design methods of predictor-based controllers.

The compensation for time-delays has been a hot topic in the control system society for several decades (Richard, 2003). On one hand, time-delay is an unavoidable issue appearing on the actuator and during the data transmission of a control system; on the other hand, time-delays often lead to a negative influence on the performance/stability of the system (Fridman, 2014, pp. vii). Several approaches could be adopted for reducing the degraded performance caused by the time-delays. The first delay compensation method is to well-adjust the control parameters for achieving as much robustness as possible against the time-delays. By virtue of the Lyapunov-Krasovskii analysis (Hale & Lunel, 2013, Chapter 5.2), it is possible to derive the delay-independent or delay-dependent stability criteria that preserve the closed-loop stability. In order to reduce the conservatism on the delay size and/or the delay derivative, the Jensen’s inequality (Gu, Chen, & Kharitonov, 2003), the Wirtinger-based inequality (Seuret & Gouaisbaut, 2013), and the Bessel–Legendre inequalities (Seuret & Gouaisbaut, 2015; Zhang, Han, Ge, & Ding, 2018; Zhang, Han, Seuret, Gouaisbaut, & He, 2019; Zhang, Han, & Ge, 2021) have been gradually involved in the Lyapunov-Krasovskii stability analysis procedure. Apart from the aforementioned methods, the second approach aims at developing a more active control structure that actively compensates for the time-delays (Smith, 1959; Artstein, 1982; Bekiaris-Liberis & Krstic, 2013b; Karafyllis & Krstic, 2017). Predictor-based control is a straightforward active method for stabilising systems with **long time-delays** because the core idea is to build control laws by using a predicted future state for counteracting the destabilising effects of the time-delays. Therefore, the main motivation of this paper is to provide a comprehensive overview and several new research trends of the predictor-based control technique, hoping to attain more effective solutions to the control of systems subject to **long time-delays**. Generally, the predictor-based control synthesis contains the following two procedures:

- predicting the system state at a future instant;
- determining the current control law based on the state prediction.

Inspired by the advances in control theory and application during the past decades, the predictor-based controller has been gradually ameliorated to deal with different types of time-delay systems, whose development history is briefly introduced in the rest of this subsection.

In the 1950s, a transfer-function-based approach named “Smith predictor” was firstly proposed to regulate an input-delay system by introducing an inner system acting as a predictor (Smith, 1959), but this method will be no longer effective if the delay-free system plant is open-loop unstable. In the 1970s-the 1980s, the concept of Smith predictor was extended to the following two methods based on the state-space representation:

- **Finite Spectrum Assignment (Manitius & Olbrot, 1979)**: this method substitutes the state prediction into a linear state-feedback controller, then the closed-loop system performs as an asymptotically stable delay-free system with finite spectrum after a finite time;
- **Model Reduction (Artstein, 1982)**: this method studies the dynamics of a transformed predictive state, and the control law is directly designed on the reduced delay-free system.

Between the 2000s and the 2010s, the predictor-based control technique has been significantly improved thanks to the partial differential equation transformation (Krstic, 2009) that describes the behaviors of the delayed input/state; in addition, the partial differential equation method enabled the compensation for the unknown long time delays through backstepping control (Krstic & Bresch-Pietri, 2009). During this period, the sampled-data version of the predictor-based controller is also intensively investigated due to the emerging study for networked control systems.

In the last decade, the integration-free predictor-based controller became another focus since the previous techniques usually contain an infinite-dimensional term, *i.e.* an integral term, that may result in implementation issues, the truncated predictor-based control (Zhou, 2014b) and observation-predictor-based control (Besançon, Georges, & Benayache, 2007) are two typical representatives of such controllers.

Presently, predictor-based control consecutively gains the attention of researchers due to the expeditious development of cyber-physical systems (CPSs), in which the inevitable time-delays need careful

concern.

### 1.1. Benefit of the predictor-based control

This subsection explains the main profit of the predictor-based controller: it is an effective approach for stabilising time-delay systems with long time delays. For instance, consider simply a linear time-invariant system with constant input delay:

$$\dot{X}(t) = AX(t) + BU(t - h), \quad (1)$$

where  $A \in \mathbb{R}^{n \times n}$ ,  $B \in \mathbb{R}^{n \times m}$ ,  $X(t) \in \mathbb{R}^n$ ,  $U(t) \in \mathbb{R}^m$ , and  $h > 0$ . The following two control laws could be potentially applied to system (1):

- **Non-predictive controllers (Lin & Fang, 2007; Liu & Fridman, 2014):**  $U(t) = K(t)X(t)$  with  $K(t) \in \mathbb{R}^{m \times n}$ ;
- **Predictor-based controller (Manitius & Olbrot, 1979):**  $U(t) = KX(t + h)$  with  $K \in \mathbb{R}^{m \times n}$ .

Remind that the non-predictive controllers (Lin & Fang, 2007; Liu & Fridman, 2014) could retain the closed-loop stability of system (1) if the time-delay  $h$  is smaller than a certain upper bound or the open-loop system satisfies some additional properties, *e.g.* all eigenvalues of  $A$  are placed on the imaginary axis. Consequently, the non-predictive controllers cannot readily stabilise unstable systems with long input delay, whereas the predictor-based controller can handle this problem since the closed-loop system of (1) is converted to:  $\dot{X}(t) = (A + BK)X(t)$ .

The aforementioned discussions indicate the motivation for designing predictor-based controllers: thanks to the effective state prediction that actively compensates for the time-delays, the controller can achieve better control performance for unstable systems subject to long time-delays.

### 1.2. Organisations and notations

**Organisations.** This survey is structured as follows. The predictor-based control techniques by using ordinary differential equation (ODE) and partial differential equation (PDE) representations are investigated in Section 2 and Section 3, respectively. Next, Section 4 analyses the integration-free predictor-based controllers, such methods can stabilise time-delay systems by means of finite-dimensional controllers. In Section 5, the implementations and applications of predictor-based controllers (*e.g.* for networked control system and multi-agent system) are summarised. Afterwards, Section 6 proposes several potential new trends for designing, analysing, and realising predictor-based controllers. Finally, the conclusion of this paper is addressed in Section 7. The outline of this survey is depicted in Figure 1.

**Notations.** In this paper, if a time-delay is written as a function of time, *e.g.*  $h(t)$ , then it represents a **time-varying delay**; otherwise, it stands for a **constant delay**. The mathematical notations and acronyms used throughout this paper are provided in Tables 1–2.

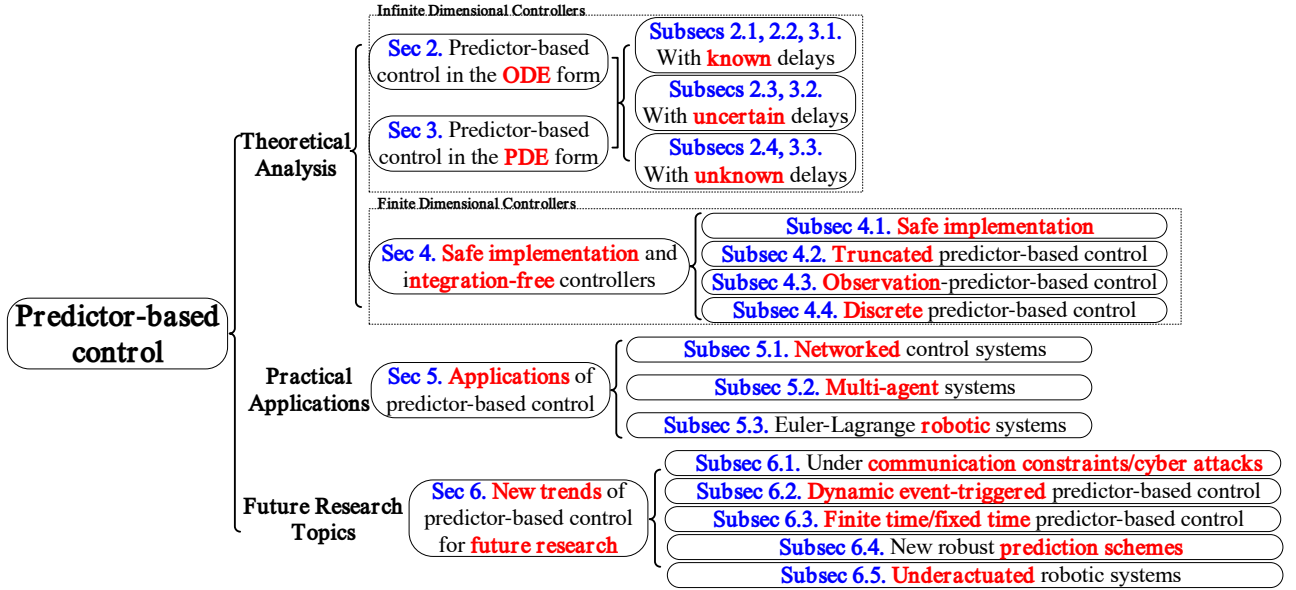

Figure 1.: Organisation of the survey.

Symbols	Description	Symbols	Description
$\mathbb{N}$	Non-negative integers	$\mathbb{N}_+$	Strictly positive integers
$\mathbb{R}^n$	Real vector with $n$ rows	$\mathbb{R}^{m \times n}$	Real matrix with size $m \times n$
$M^{-1}$	Inverse of an invertible matrix/function $M$	$M^T$	Transpose of matrix $M$
$\bar{\lambda}(P)$	Maximum eigenvalue of symmetric positive definite matrix $P$	$\underline{\lambda}(P)$	Minimum eigenvalue of symmetric positive definite matrix $P$
$\lambda\{P\}$	Spectrum of matrix $P$	$I_n$	Identity matrix with dimension $n$
$\ x\ $	Euclidean norm of vector $x$	$\ M\ $	Spectral norm of matrix $M$
$\mathbf{C}^n([a, b])$	Functions with $n$ -times continuously differentiable derivatives on $[a, b]$	$x_t : [-h, 0] \mapsto \mathbb{R}^n$	Infinite-dimensional state $x(t + \theta)$ with $\theta \in [-h, 0]$
$u_x(x, t)$	Partial derivative of $u(x, t)$ with respect to spatial parameter $x$	$u_t(x, t)$	Partial derivative of $u(x, t)$ with respect to temporal parameter $t$
$\Phi_A(t_1, t_0)$	State transition matrix with respect to $A$ from $t_0$ to $t_1$	$\phi(t)$	Delayed instant $\phi(t) = t - h(t)$
$\dot{X}(\phi(t))$	Derivative of function $X(\cdot)$ at horizon $\phi(t)$	$\frac{d}{dt}(X(\phi(t)))$	Time-derivative of composite function $t \mapsto X(\phi(t))$
$\mathcal{L}(\cdot)$	Laplace transform	$\mathcal{L}^{-1}(\cdot)$	Inverse Laplace transform
$\lfloor \cdot \rfloor$	Floor function		

Table 1.: List of notations.

Acronyms	Description	Acronyms	Description
TDS	Time-Delay System	NCS	Networked Control System
MAS	Multi-Agent System	LMI	Linear Matrix Inequality
ODE	Ordinary Differential Equation	PDE	Partial Differential Equation
LTI	Linear Time-Invariant	LPV	Linear Parameter-Varying
MATI	Maximum Allowable Transmission Interval	MAD	Maximum Allowable Delay
FSA	Finite Spectrum Assignment	CPS	Cyber-Physical System
ARE	Algebraic Riccati Equation	DRE	Differential Riccati Equation
GUAS	Globally Uniformly Asymptotically Stable	GUES	Globally Uniformly Exponentially Stable
SISO	Single Input Single Output	MIMO	Multiple Input Multiple Output
RoA	Region of Attraction	DoF	Degree of Freedom
ISS	Input-to-State Stable	CCL	Cone Complementarity Linearisation
ZOH	Zero-Order Holder	DOB	Disturbance Observer
RCS	Remote Control System	ESO	Extended State Observer
HOSM	High-Order Sliding Mode		

Table 2.: List of acronyms.

## 2. Predictor-based control in the ODE form

This section investigates the ODE-based design methods of the predictor-based control for various control systems with known, partially known, or even unknown time-delays. The rest of this section discusses and compares the existing predictor-based control methods designed by ODE approaches.

### 2.1. Smith predictor, Finite Spectrum Assignment, and model reduction

Smith predictor (Smith, 1959) is the first reported predictor-based controller for stable LTI systems with constant and known input delay. The system (1) is converted to a transfer function  $H(s) = H_0(s)e^{-hs} = N(s)e^{-hs}/D(s)$ , the schematic displayed in Figure 2 is utilised to generate the control law, which leads to the following closed-loop transfer function:

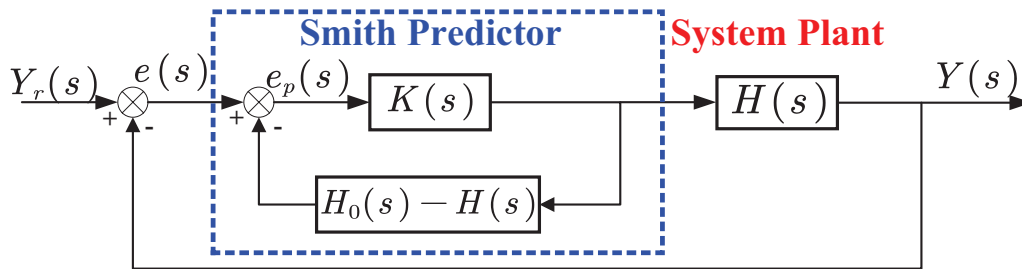

Figure 2.: Smith predictor for TDS with constant input delay.

$$\frac{Y(s)}{Y_r(s)} = \frac{K(s)N(s)}{D(s) + K(s)N(s)} e^{-hs}. \quad (2)$$

Thanks to the predictive inner loop provided in Figure 2, the gain  $K(s)$  can be simply designed to stabilise the delay-free system  $H_0(s)$  since the delayed term  $e^{-hs}$  cannot influence the closed-loop stability of (2). Thereafter, the modified Smith predictors (Watanabe & Ito, 1981; Furukawa & Shimemura, 1983) have been developed to deal with unstable systems with long time-delays.

The main principles of designing Smith predictors are extended to the state space methods for obtaining a more rigorous stability analysis, FSA (Manitius & Olbrot, 1979) and model reduction (Artstein, 1982) are two representatives of such approaches. In FSA (Manitius & Olbrot, 1979), one firstly predicts the future state of (1) by using variation of parameters as follows:

$$X(t+h) = e^{Ah}X(t) + \int_{t-h}^t e^{A(t-s)}BU(s)ds. \quad (3)$$

Therefore, the state-feedback control law  $U(t) = KX(t+h)$  leads to the closed-loop system:

$$\dot{X}(t) = \begin{cases} (A+BK)X(t), & t \geq h, \\ e^{At}X(0) + \int_0^t e^{A(t-s)}BU_0(s)ds, & 0 \leq t < h, \end{cases} \quad (4)$$

with initial condition  $U_0(\theta) = U(\theta-h) \in \mathbf{C}^1([-h,0])$ ,  $\theta \in [0,h]$ . For all  $t \geq h$ , the closed-loop system (4) becomes a finite-dimensional delay-free system whose stability can be guaranteed by making  $A+BK$  Hurwitz. Hence, distinct to the Smith predictor, FSA can readily stabilise stable/unstable LTI systems with long time-delays.

The model reduction (Artstein, 1982) technique is based on the following auxiliary variable:

$$Z(t) = X(t) + \int_{t-h}^t e^{A(t-s-h)}BU(s)ds. \quad (5)$$

Differentiating (5) along the trajectories of (1) leads to the delay-free auxiliary system:

$$\dot{Z}(t) = AZ(t) + e^{-Ah}BU(t), \quad (6)$$

which turns the time-delay  $h$  into a parameter of the finite-dimensional delay-free system (6). Under an appropriate state-feedback control law  $U(t) = KZ(t)$  that makes  $A + e^{-Ah}BK$  Hurwitz stable, system (6) becomes GUES, and the stability/boundedness of the original state  $X(t)$  can be derived from (5). In addition, the robustness, with respect to state-dependent perturbations, of the model reduction technique was analyzed in (Roh, 2002) and several delay-dependent conditions were derived to preserve the closed-loop asymptotic stability.

Comparing (3) and (5), it is worthwhile pointing out that the controllers based on FSA and model reduction have the similar structure due to the fact that  $X(t+h) = e^{Ah}Z(t)$ , but the core ideas of them are different: FSA can directly provide the stability results of the original system whereas the model reduction focuses on the auxiliary system. In general, the model reduction technique is more suitable for control systems subject to uncertain/unknown time-delays since the perfect state prediction  $X(t+h)$  cannot be perfectly obtained. However, FSA is still able to solve such control problems through the PDE methods introduced in Section 3.

Furthermore, the controllability, stabilisation, and real-time implementation of predictor-based controllers for several classes of nonlinear systems under constant input and measurement delays was systematically investigated in (Karafyllis & Krstic, 2017, Part II), whose core idea is still based on FSA and model reduction.

## 2.2. Predictor-based control in the ODE form of systems with known time-varying delays

This subsection recalls the predictor-based control of TDSs with known time-varying delays developing from the conventional methods.

**Predictor-based control of linear TDSs.** Consider the control of the following LTI TDS:

$$\dot{X}(t) = AX(t) + BU(t-h(t)) = AX(t) + BU(\phi(t)), \quad (7)$$

with  $\phi(t)$  defined in Table 1 and the input delay  $h(t)$  satisfying  $0 < h(t) \leq h_{max} < +\infty$  and  $|\dot{h}(t)| \leq \varepsilon < 1$ . Thus, the delay operator  $\phi(t) = t - h(t)$  is differentiable, strictly increasing, and invertible. The authors of (Nihtilä, 1991) proposed the following FSA controller:

$$U(t) = KX(\phi^{-1}(t)) = K \left[ e^{A(\phi^{-1}(t)-t)}X(t) + \int_t^{\phi^{-1}(t)} e^{A(\phi^{-1}(t)-s)}BU(\phi(s))ds \right] \quad (8)$$

to system (7) in order to render GUES the following closed-loop system:

$$\dot{X}(t) = AX(t) + BKX(\phi^{-1}(\phi(t))) = (A+BK)X(t). \quad (9)$$

Even though the method in (Nihtilä, 1989, 1991) stabilises the system (7) in a quite simple way, the control law (8) needs the explicit knowledge of  $\phi^{-1}(t)$ , which cannot be easily obtained in practice since it depends on the future value of the time-delay. To overcome this drawback, two methods can be potentially adopted:

- developing an appropriate adaptation law to estimate  $\phi^{-1}(t)$ ;
- in (8), replacing the prediction horizon  $\phi^{-1}(t)$  by a causal one  $t+h(t)$  for approximation, which only relies on the current delay value.

In (Witrant, Canudas-de Wit, Georges, & Alamir, 2004, 2007), the following updating law was designed to provide an online estimate of  $\delta(t) \triangleq \phi^{-1}(t) - t$ :

$$\dot{\hat{\delta}}(t) = -\frac{\lambda\hat{\delta}(t)}{1-\dot{h}(\hat{\zeta}(t))} + \frac{\dot{h}(\hat{\zeta}(t)) + \lambda h(\hat{\zeta}(t))}{1-\dot{h}(\hat{\zeta}(t))} \quad (10)$$



with  $\hat{\zeta}(t) = t + \hat{\delta}(t)$  and a sufficiently large gain  $\lambda > 0$ . Next, the global asymptotic stability of the closed-loop system can be derived by analyzing the dynamics of the auxiliary state  $Z(t) = X(t + \delta(t))$  through the model reduction approach, and the closed-loop system reads as:

$$\dot{Z}(t) = \frac{d}{dt}(X(t + \delta(t))) = (1 + \dot{\delta}(t)) \left[ (A + BK)X(t + \delta(t)) + BK \left( X(t + \hat{\delta}(t)) - X(t + \delta(t)) \right) \right]. \quad (11)$$

In (Léchappé, Moulay, & Plestan, 2018, Corollary 3.1), the approximated prediction horizon  $\phi^{-1}(t) \approx t + h(t)$  was utilized to build a control law, this approach was recently developed in (Dev, Léchappé, & Sarkar, 2021) to stabilise delayed power systems subject to input and state delays. By employing a model reduction-based stability analysis, the main results in (Léchappé et al., 2018; Dev et al., 2021) demonstrated that the approximated predictor-based controller can preserve the stability of (7) if  $|\dot{h}(t)|$  is smaller than a certain upper bound. Remind that the stability criteria in (Léchappé et al., 2018) solely depends on the variation of the time-delay, which indicates that the approximated prediction scheme is effective for a class of TDSs with arbitrarily long but slow-varying input delays. Besides, the model reduction techniques mentioned above can be extended to stabilise LTI systems with time-varying input and measurement delays. For instance, consider the following LTI system:

$$\begin{cases} \dot{X}(t) = AX(t) + BU(t - h_I(t)), \\ Y(t) = X(t - h_O(t)), \end{cases} \quad (12)$$

with the input delay and output delay satisfying  $|\dot{h}_I(t)| \leq \varepsilon_I < 1$ ,  $|\dot{h}_O(t)| \leq \varepsilon_O$  respectively. The control objective of (12) is designing a predictor-based controller by using the delayed state measurement  $Y(t)$  and the history of the control input  $U_t$ . In the presence of output delay  $h_O(t)$ , the exact prediction horizon  $\phi^{-1}(t)$  is difficult to determine or to estimate in practice due to its complex expression, but the approximated prediction horizon can lead to a more concise expression. In (Léchappé et al., 2018, Theorem 1) the approximated round-trip delay  $h(t) = h_I(t) + h_O(t)$  was employed to compute the following control law for system (12):

$$U(t) = K \left[ e^{Ah(t)} X(t - h_O(t)) + \int_{t-h(t)}^t e^{A(t-s)} BU(s) ds \right]. \quad (13)$$

Moreover, the combination of (13) and an alternative round-trip delay  $h(t) = h_O(t) + h_I(t - h_O(t))$ , which is easier to measure/estimate in practice, was analyzed in (Deng, Léchappé, Molay, & Plestan, 2021, Proposition 1) to deal with the same control problem. Both methods can stabilise (12) if the input delay  $h_I(t)$  varies sufficiently slowly, and the closed-loop stability can be sustained even if the measurement delay is fast-varying, *i.e.* distinct from the input delay  $h_I(t)$ , the derivative of the output delay  $h_O(t)$  is not restricted to be less than 1. Thus, the predictor-based control with approximated prediction horizon can provide a tradeoff between the theoretical analysis and the practical implementation.

**Predictor-based control of nonlinear TDSs.** Subsequently, the predictor-based control in the ODE form of nonlinear systems under time-varying delays is overviewed. Indeed, such a control problem is an important but challenging task to the control community according to the following reasons:

- **Challenge 1:** the superposition of nonlinearity and time-varying delay may affect the forward completeness of the system (Angeli & Sontag, 1999), (Krstic, 2010a, Section VI) and lead to finite-time escape, especially for non-Lipschitz systems;
- **Challenge 2:** if the time-delay is state-dependent, then the prediction horizon  $\phi^{-1}(t)$  is nearly uncomputable, and the global stabilisation of such systems is almost impossible. For such control systems, the RoA should be carefully analysed to ensure local stability;
- **Challenge 3:** since the analytical solution to the delayed nonlinear system is difficult to obtain, the approximation of the predictor plays a regulatory role in the stabilisation problem (Karafyllis & Krstic, 2017, pp. 118), and the numerical implementation needs further consideration as well.

Several references have considered one or more challenges mentioned above. A tutorial on the predictor-based control of nonlinear TDSs is available in (Krstic & Bekiaris-Liberis, 2012), which studies the

compensations for the state-independent and state-dependent time-varying input and state delays. Thereafter, a complete procedure was provided in (Bekiaris-Liberis & Krstic, 2013a) to deal with the predictor-based control of nonlinear systems with state-dependent input delays, including the controller design, the stability analysis, and the RoA-estimation. In (Dinh, Fischer, Kamalapurkar, & Dixon, 2013), the predictor-based control technique was involved in the robust output-feedback trajectory tracking control of uncertain second-order nonlinear systems with slowing-varying input delays, the main results of this paper can be extended to a class of practical Euler-Lagrange systems. An approximated predictor-based controller was exploited in (Liu & Sun, 2018) for nonlinear systems with known time-varying input delays and unknown time-varying state delays, another contribution of this paper is the detailed analysis of the digital implementation of the control law. In (Deng, Yao, & Ma, 2018), a robust output-feedback predictive controller was proposed for nonlinear systems with time-varying input delays and additive disturbances.

This subsection has introduced the predictor-based control in the ODE form of linear and nonlinear systems with time-varying delays, the main difficulty of this topic is designing a suitable prediction scheme that approaches the analytical state prediction for preserving the closed-loop stability. More discussions about the nonlinear predictor-based controllers will be given in Subsection 3.1 with the help of PDE methods.

### 2.3. Predictor-based control in the ODE form of systems with uncertain time-delays

Subsections 2.1 and 2.2 demonstrate the strength of predictor-based controllers in stabilising linear/nonlinear systems with long constant/time-varying delays. An essential factor of designing such controllers is the exact state prediction by using the delay value. Nevertheless, one must verify whether the closed-loop stability can still be preserved when an approximated delay is plugged into the predictor since the perfect measurement of the time-delays is almost impossible in practical control systems. Several researchers gave positive answers to this question by analysing the robustness to delay mismatches, also called the “delay-robustness”.

This subsection provides an investigation on the predictor-based control of systems with uncertain delays, where the exact delay  $h = h_n + \Delta h$  could be regarded as the sum of a known nominal delay  $h_n$  that is available for the controller design and an unknown delay uncertainty  $\Delta h$ . Remind that both  $h$  and  $h_n$  could be constant or time-varying, then the existing methods are classified into the following Table 3.

In the 2000s, the control community was concentrated on analyzing the delay-robustness through spec-

Approximated Delay \ Actual Delay	Constant $h_n$	Time-varying $h_n(t)$
Constant $h$	(Mondié, Niculescu, & Loiseau, 2001) (Michiels & Niculescu, 2003) (Li, Zhou, & Lin, 2014) (Nandiganahalli, Kwon, & Hwang, 2019) (Mattioni, Monaco, & Normand-Cyrot, 2020)	Unnecessary
Time-varying $h(t)$	(Karafyllis & Krstic, 2013a) (Lhachemi, Prieur, & Shorten, 2019) (Lhachemi, Prieur, & Shorten, 2020) (Lhachemi, Prieur, & Shorten, 2021)	(Léchappé, Moulay, & Plestan, 2018)

Table 3.: Existing literature on the predictor-based control (ODE form) of systems with uncertain delays.

trum approaches, where the actual and the approximated delays were both assumed to be constant. In (Mondié et al., 2001), the delay-robustness of FSA was examined by deriving the closed-loop characteristic equations; the main results emphasized that the asymptotic stability could be maintained in the presence of slight delay uncertainties. On the foundation in (Mondié et al., 2001), another frequency domain analysis was conducted in (Michiels & Niculescu, 2003) for studying the behaviors of the Smith predictor under delay mismatches, which was applicable to non-strictly proper systems and MIMO systems. In (Karafyllis & Krstic, 2013a), a constant-delay predictor was applied to TDSs with

uncertain time-varying delays; it was remarkable to observe that the stability criteria only depends on the size of the delay uncertainty, rather than the delay derivative; and the assumption  $|\dot{h}(t)| \leq \varepsilon < 1$  could be removed in this case. However, it was emphasized in (Li et al., 2014) that the robustness analysis in (Karafyllis & Krstic, 2013a) was conservative for constant uncertain delays since the delay derivative was taken into account by the framework, then an enhanced method was proposed to reduce the conservatism in (Karafyllis & Krstic, 2013a). Recently, a less conservative LMI-based method was suggested in (Lhachemi et al., 2019) for analysing the constant-predictor for time-varying delays; this approach was further developed in (Lhachemi et al., 2020, 2021) for multi-input systems and reaction-diffusion PDEs, respectively. The authors of (Nandiganahalli et al., 2019) resolved the adaptive trajectory tracking control of linear TDSs under parameter uncertainties and input disturbances, the maximum allowable delay mismatch was explicitly computed to preserve the ultimately bounded tracking errors. In (Mattioni et al., 2020), the constant-predictor for uncertain constant delay was designed for delayed port-controlled Hamiltonian systems.

In (Léchappé, Moulay, & Plestan, 2018), an output-feedback controller using variable approximated delay was developed for LTI systems with time-varying input delay and output delay. This control scheme can also collaborate with delay estimation techniques for TDSs with unknown delays. Under this situation, the nominal variable delay could be regarded as the online estimation of the unknown delay, the TDS will be stabilised as long as the delay estimation becomes sufficiently accurate.

#### 2.4. Predictor-based control in the ODE form of systems with unknown time-delays

Subsection 2.3 reveals the fact that the predictor-based controller can still preserve the closed-loop stability when a sufficiently precise delay approximation is utilised for the state prediction. Nevertheless, such an accurate value is not always available in practice: the prior knowledge about the delay could be outside the stabilising interval or even unknown. For these circumstances, more active methodologies should be developed to cope with “larger” delay deviations and unknown time-delays.

This subsection introduces the predictor-based control of systems with unknown time-delays, where the exact/nominal values of the time-delay  $h$  or  $h(t)$  are unavailable to the controller, and one can only use the delay lower/upper bounds  $h_{min}, h_{max}$  to build the control law. In general, four different approaches are capable of attaining the active compensation for unknown time-delays, a brief overview of which is provided subsequently:

- **Unknown delay compensation without delay estimation:** this method aims to build the robust control law by using the upper bound  $h_{max}$  and the lower bound  $h_{min}$  on the unknown delay, which yields a significant enlargement of the delay-robustness. In addition, the truncated predictor-based controllers can also be classified into this category, these approaches will be emphasised in Subsection 4.2.
- **Switching logic-based delay estimation:** the core idea of these methods is to separate the delay bound  $[h_{min}, h_{max}]$  into several sufficiently dense disjoint sub-intervals  $\cup_{i=0}^N [h_i, \hat{h}_{i+1})$ , a switching mechanism is then conducted to determine the membership of the unknown delay to the sub-intervals. Finally, the TDS could be stabilised as long as the delay estimation becomes adequately accurate.
- **Dynamic delay estimation:** these methods are absorbed in designing a continuous-time online delay estimator that approaches the unknown time-delay, for deriving the closed-loop stability via Lyapunov-Krasovskii theorem (Fridman, 2014, Theorem 3.1) or Lyapunov-Razumikhin theorem (Fridman, 2014, Theorem 3.2).
- **Practical delay estimation:** these approaches are especially devoted to the predictor-based control of networked-based control systems, *e.g.* NCSs and RCSs, of which the time-delays arise from data communications. Therefore, it is possible to develop some practical delay estimation algorithms that fully leverage the convenience of the communication channel.

The remainder of this subsection will individually elucidate the four methods mentioned above.

**Unknown delay compensation without delay estimation.** The first control solution

(Polyakov, Efimov, Perruquetti, & Richard, 2013) was proposed to stabilise the following TDS:

$$\begin{cases} \dot{X}(t) = AX(t) + BU(t - h(t)), \\ Y(t) = CX(t), \end{cases} \quad (14)$$

where  $h(t) \in [h_{min}, h_{max}]$  is unknown and  $A, B, C$  have appropriate dimensions. Let  $\underline{(\cdot)}$  and  $\overline{(\cdot)}$  denote the componentwise lower/upper bounds as follows:

$$\underline{B'U}(t) = \min_{\theta \in [0, h_{max} - h_{min}]} B'U(t - \theta), \quad \overline{B'U}(t) = \max_{\theta \in [0, h_{max} - h_{min}]} B'U(t - \theta). \quad (15)$$

For well-chosen matrices  $S$  and  $L$ , it is possible to establish the following coordinate transformations:

$$\tilde{A} = S^{-1}AS, \quad \tilde{B} = S^{-1}B, \quad \tilde{L} = S^{-1}L, \quad \tilde{C} = SC. \quad (16)$$

Under (15)–(16), the enhanced predictor-based controller writes as

$$U(t) = \frac{1}{2}K (\bar{Z}(t) + \underline{Z}(t)), \quad (17)$$

where  $K$  is determined to satisfy certain LMIs and  $\bar{Z}(t)$ ,  $\underline{Z}(t)$  are computed subsequently:

$$\begin{aligned} \bar{Z}(t) &= e^{\tilde{A}h_{max}} \bar{X}(t) + \int_{-h_{min}}^0 e^{-A\theta} \underline{B'U}(t + \theta) d\theta, \quad \dot{\bar{X}}(t) = \tilde{A}\bar{X}(t) + \overline{B'u}(t - h_{min}) + \tilde{L} (\tilde{C}\bar{X}(t) - Y(t)) \\ \underline{Z}(t) &= e^{\tilde{A}h_{min}} \underline{X}(t) + \int_{-h_{min}}^0 e^{-A\theta} \overline{B'U}(t + \theta) d\theta, \quad \dot{\underline{X}}(t) = \tilde{A}\underline{X}(t) + \underline{B'u}(t - h_{min}) + \tilde{L} (\tilde{C}\underline{X}(t) - Y(t)). \end{aligned} \quad (18)$$

The control scheme constructed by (17)–(18) could stabilise LTI systems with unknown bounded time-varying input delays if the matrices  $L$  and  $K$  are carefully tuned. In contrast to (3), this method utilises the whole delay variation interval  $h(t) \in [h_{min}, h_{max}]$  to build the robust approximated state predictions  $\bar{Z}(t)$ ,  $\underline{Z}(t)$ , this is the reason why this approach is named the “interval prediction” technique.

The interval prediction method (Polyakov et al., 2013) exploits a robust controller to face the unknown time-delays, but the control performances will be possibly degraded if  $h_{min}$  is highly underestimated and/or  $h_{max}$  is highly overestimated. A possible way to handle this problem is to generate the control law by adding a delay estimation algorithm that approaches the unknown time-delay, at least providing a tighter delay interval that yields a more accurate state prediction. In the sequel, one will firstly review the predictor-based controllers with switching logic-based delay estimations.

**Switching logic-based delay estimation.** In (Alcántara, Ibeas, Herrera, Vilanova, & Pedret, 2009; Herrera & Ibeas, 2012) a multi-model switching algorithm was proposed to deal with the trajectory tracking of LTI uncertain systems with unknown input delays, the core idea of these approaches is depicted in Figure 3. While the control signal  $U(t)$  is injected into the system plant, it is also applied to several virtual systems  $G_i(s) = G(s)e^{-\hat{h}_i s}$ ,  $i \in \{1, 2, \dots, N\}$  with distinct artificial delays  $\hat{h}_1, \hat{h}_2, \dots, \hat{h}_N$ . Thereafter, the output  $Y(t)$  is compared with the outputs of the “system copies”, and the online delay identification  $\hat{h}(t)$  could be selected as the candidate delay  $\hat{h}_i$  that brings about the smallest error between the output  $Y(t)$  and the virtual ones. Finally, a modified Smith predictor using the estimated delay information guarantees the tracking performances of the stable/unstable system plant  $G(s)e^{-hs}$ .

A similar method was adopted in (Huang & Yu, 2017) with a more comprehensive Lyapunov-Krasovskii stability analysis. This work tackles the stabilisation of (1) with unknown input delay  $h \in [h_{min}, h_{max}]$ . In this paper, one considers the model reduction

$$Z(t, \hat{h}_r) \triangleq X(t) + e^{A(t-\hat{h}_r)} \int_{t-\hat{h}_r}^t e^{-A\theta} BU(\theta) d\theta \quad (19)$$

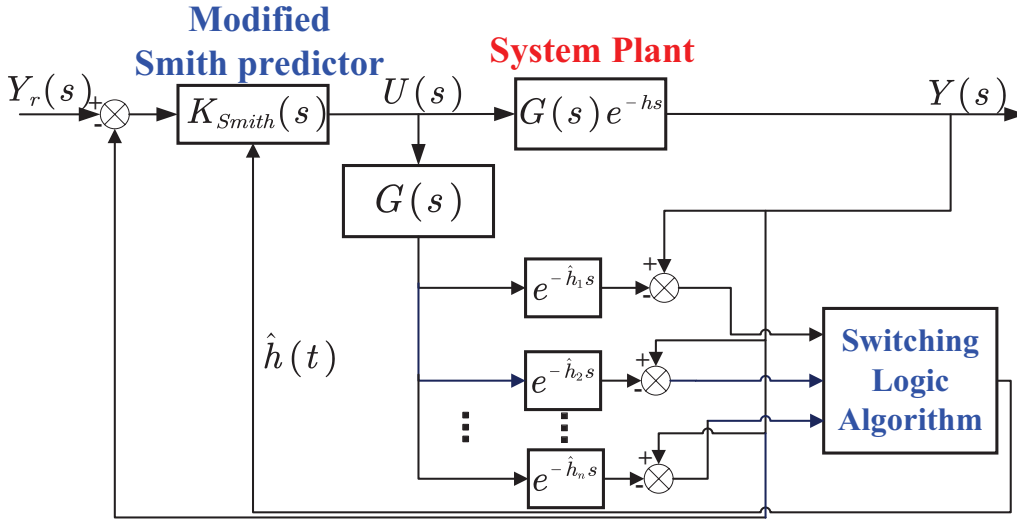

Figure 3.: Schematic of the multi-model delay identification algorithm.

and splits the delay variation interval into several sub-intervals  $\cup_{i=0}^N [\hat{h}_i, \hat{h}_{i+1})$ . A straightforward Lyapunov-Krasovskii analysis indicates that if the delay error  $|\hat{h}_r - h|$  is sufficiently small, then there must exist a Lyapunov candidate functional  $V_r(t)$ , a symmetric positive definite matrix  $P_r$ , and a positive constant  $\varepsilon_r$  satisfying:

$$V_r(t) - V_r(p_r) \leq -\varepsilon_r \int_{p_r}^t Z^T(\theta, \hat{h}_r) P_r^{-1} Z(\theta, \hat{h}_r) d\theta \quad (20)$$

for all  $t \geq p_r$ . Therefore, if (20) fails to hold, then the estimated delay value  $\hat{h}_r$  must be inaccurate. The discussions mentioned above are the key to the delay estimation algorithm: if inequality (20) is violated for  $\hat{h}(t) = \hat{h}_{r-1}$  at instant  $p$ , then one notes  $p_r = p$  and assigns  $\hat{h}(t) = \hat{h}_r$ . Thanks to the Lyapunov functional-based switching mechanism, there must exist an instant  $t_0 > 0$  such that (20) holds afterwards, which will certainly derive the closed-loop stability.

Another switching logic-based method was carried out by (Gaudette & Miller, 2014, 2016), in which the continuous-time system was discretised for the controller design. At each switching instant, the current state information and input values are compared with the previous ones, then the unknown time-varying delay can be approximated by solving a discrete-time algebraic equation. Finally, a robust predictor-based controller is designed to ensure the input-to-state stability and enlarge the delay margin of the original system.

The switching logic-based delay estimation methods can effectively assist the predictor-based controller in stabilising uncertain TDSs subject to unknown time-delays, and the estimation algorithms can be extended for unknown time-varying delays. However, these approaches may not attain a good control performance when the time-delay is long: the computational costs of (Alcántara et al., 2009; Herrera & Ibeas, 2012) will strongly increase since the number of multi-models  $N$  depend on the delay size, and the response in (Huang & Yu, 2017) must suffer from a long-term unstable transient caused by the step-by-step delay estimation mechanism. In the sequel, one will introduce the dynamic delay estimation techniques that resolve the above drawbacks.

**Dynamic delay estimation.** The dynamic delay estimation methods are dedicated to developing an appropriate updating law  $\hat{h}(t)$  that estimates the unknown time-delay and further results in the closed-loop stability. The control framework of these methods are presented in Figure 4.

Generally, the candidate cost functions

$$J = \frac{1}{2} (h - \hat{h}(t))^2, \quad (21)$$

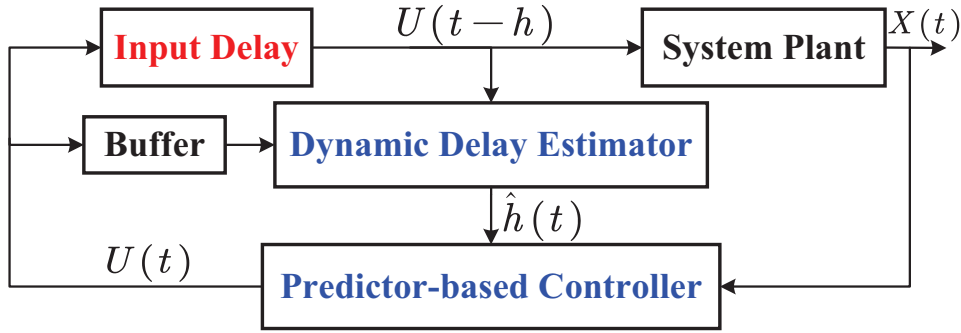

Figure 4.: Schematic of the predictor-based controller with dynamic delay estimation algorithm.

or

$$J = \frac{1}{2} \left\| u(t-h) - u(t-\hat{h}(t)) \right\|^2, \quad (22)$$

could be selected for designing the delay estimator. In (Diop, Kolmanovsky, Moraal, & Van Nieuwstadt, 2001), the quadratic function (21) was treated as a Lyapunov function and the following delay estimator was proposed to approximate the constant delay  $h > 0$ :

$$\dot{\hat{h}}(t) = -\frac{p(t)\dot{u}(t-\hat{h}(t))}{1+p(t)\dot{u}^2(t-\hat{h}(t))} \left( u(t-h) - u(t-\hat{h}(t)) \right), \quad \begin{cases} \dot{p}(t) = \frac{p^2(t)\dot{u}^2(t-\hat{h}(t))}{1+p(t)\dot{u}^2(t-\hat{h}(t))}, \\ p(0) > 0. \end{cases} \quad (23)$$

Hereafter, the delay estimation (23) was applied in the speed control of an automotive engine with unknown time-delay. In (Léchappé et al., 2016), the gradient descent method was involved to minimise the cost function (22):

$$\dot{\hat{h}}(t) = \text{Proj}_{[h_{min}, h_{max}]}(\tau_h), \quad \tau_h = \rho \left( u(t-h(t)) - u(t-\hat{h}(t)) \right) \dot{u}(t-\hat{h}(t)), \quad (24)$$

with  $\rho > 0$  and standard projector  $\text{Proj}_{[h_{min}, h_{max}]}(\cdot)$  defined in (Krstić, Kanellakopoulos, & Kokotović, 1995, Appendix E). Unless (23), the updating scheme (24) is able to estimate slow-varying delays, and it was illustrated by the predictor-based speed-servo control of a DC motor under time-varying input delay, model uncertainties, and external disturbances. In addition, the gradient descent-based delay estimators were also studied by (Novella-Rodríguez, Witrant, del Muro-Cuellar, & Márquez-Rubio, 2019; Dev, Anand, & Sarkar, 2019); the details of them are omitted since the expressions of  $\dot{\hat{h}}(t)$  are very similar to (24).

Nevertheless, the delay estimators (23)–(24) are all based on the assumption that  $|\dot{u}(t)| \geq \alpha > 0$  holds for any time, which guarantees the delay-identifiability (Drakunov, Perruquetti, Richard, & Belkoura, 2006) of the system but is difficult to fulfill in the closed-loop stabilisation problem since  $u(t)$  cannot change its sign under this assumption. Hereafter, a closed-loop constant delay estimation technique will be explained to relax the above limitation, whose core idea is very similar to the switching algorithm (Huang & Yu, 2017). Consider the delay estimation law:

$$\dot{\hat{h}}(t) = \|u(t-h) - u(t-\hat{h}(t))\|, \quad \hat{h}(0) = h_{min}, \quad (25)$$

which is initialised at the lower bound  $h_{min}$  and keeps non-decreasing for all  $t \geq 0$ . The increment of  $\hat{h}(t)$  could be viewed as a “searching” behavior in the delay variation interval  $h \in [h_{min}, h_{max}]$ , and  $\hat{h}(t)$  will ultimately converge towards a close enough limit  $\bar{h}$  that ensures the closed-loop stability. This approach was utilised in (Deng, Léchappé, Moulay, & Plestan, 2019) for the predictor-based output-feedback control of LTI systems subject to unknown constant input delay and output delay; the method was modified in (Deng, Léchappé, Moulay, & Plestan, 2021) with an improved delay estimation accuracy. Moreover, several references (Léchappé, De Leon, Moulay, Plestan, & Glumineau, 2018;

Chen, Edwards, Alwi, & Sato, 2022) considered the open-loop dynamic delay estimation problem, *i.e.* without consideration of controller design nor experimental validation like (Diop et al., 2001; L  chapp   et al., 2016). But it could be inferred that these approaches can cooperate with predictor-based controllers for regulating TDSs with unknown time-delays.

**Practical delay estimation.** Finally, one briefly introduces the predictor-based control of network-based control systems with the help of practical delay estimation techniques. In (Lai & Hsu, 2010), the time-stamp technique was adopted to estimate the round-trip delay of RCSs, *i.e.* the system clock information was transmitted over the control framework to measure the transmission delays. Next, the online estimation of the round-trip delay was plugged into an adaptive Smith predictor for stabilising the system. The effectiveness of the control scheme was validated by the remote control of a 15km distanced servo motor. Hereafter, the robustness of the practical delay estimation algorithm in (Lai & Hsu, 2010) was improved by (Deng, L  chapp  , Rouquet, Moulay, & Plestan, 2020b, 2020a) via sliding mode control approaches, and a closed-loop stability of the controlled RCS was analysed in (Deng, L  chapp  , et al., 2021). It is concluded that the practical algorithms could practically estimate fast-varying delays, and the predictive control scheme can compensate for fast-varying output delays in the communication loop.

## 2.5. Section review

This section recalls the existing literature about the predictor-based control in the ODE form of different TDSs. By forecasting the future state, the proposed control technique can convert the infinite-dimensional TDSs to finite-dimensional ones, which brings in great convenience for stabilising TDSs with considerably long time-delays. Hereafter, the delay-robustness analysis implies that the predictor-based controller is still effective when the applied prediction horizon is not too faraway from the exact ones. Subsection 2.4 generalises and classifies several augmented predictor-based control methods for sustaining the closed-loop stability under the circumstances that the time-delays are unknown. However, the methods/techniques mentioned throughout this section are degraded by the following issues:

- The delay estimation algorithms discussed in Subsection 2.4 often lead to conservatism when considering the closed-loop stabilisation problem; the methodology could be further ameliorated.
- The state prediction (3) is infinite-dimensional due to the existence of the integral term; improper numerical implementations can affect the computation efficiency or cause instability.

In order to get rid of the two drawbacks mentioned above, one would like to elaborate the PDE versions of the predictor-based controllers and several integration-free predictive controllers in Sections 3 and 4, respectively.

### 3. Predictor-based control in the PDE form

In this section, the predictor-based control in the PDE form (Krstic, 2009) is introduced. It transforms the infinite-dimensional system to a coupled system consisting of a finite-dimensional ODE subsystem and a hyperbolic transport PDE subsystem. Distinct from FSA, an additional transport PDE is introduced to describe the behaviors of the infinite-dimensional actuator state, which contributes to a more complete/rigorous closed-loop stability analysis in a strict Lyapunov sense.

#### 3.1. PDE transformation and predictor-based control of time-delay systems with known time delays

Above all, the basic concept of the predictor-based control in the PDE form is explained by considering the controller design of (1). Let  $u(x, t) = U(t + h(x - 1))$ ,  $x \in [0, 1]$  denote the solution to the following transport PDE:

$$\begin{aligned} hu_t(x, t) &= u_x(x, t), \\ u(0, t) &= U(t - h). \end{aligned} \quad (26)$$

Then the original system (1) is transformed into the following coupled ODE-PDE systems:

$$\Sigma_u : \begin{cases} \dot{X}(t) = AX(t) + Bu(0, t), \\ hu_t(x, t) = u_x(x, t), \\ u(1, t) = U(t), \end{cases} \quad \Sigma_w : \begin{cases} \dot{X}(t) = (A + BK)X(t) + Bw(0, t), \\ hw_t(x, t) = w_x(x, t), \\ w(1, t) = 0, \end{cases} \quad (27)$$

where  $K \in \mathbb{R}^{m \times n}$  makes  $A + BK$  Hurwitz stable, and  $w(x, t)$  reads as:

$$w(x, t) = u(x, t) - K \left[ e^{Ahx} X(t) + h \int_0^x e^{Ah(x-y)} Bu(y, t) dy \right]. \quad (28)$$

Substituting  $x = 1$  into (28) provides the PDE version of the predictor-based control law:

$$U(t) = u(1, t) = K \left[ e^{Ah} X(t) + h \int_0^1 e^{Ah(1-y)} Bu(y, t) dy \right], \quad (29)$$

which is equivalent to the ODE-controller  $U(t) = KX(t + h)$  computed by FSA (3). The main benefit of the PDE method is the use of (26), which models the input delay as a parameter of the coupled system and converts (1) to (27). Thanks to this manipulation and the low-triangular structure of (28), the target system  $\Sigma_w$  possesses a Hurwitz stable nominal part  $(A + BK)X(t)$ , and the exponential stability of  $X(t)$  can be directly derived from a simple Lyapunov-Krasovskii analysis.

The backstepping transformation  $(X, u) \mapsto (X, w)$  is the key to the PDE-based method, which enables the closed-loop system to approximate the prescribed GUAS target system  $\Sigma_w$ . Therefore, if one selects a proper backstepping transformation, the predictor-based controller in the PDE form will be straightforwardly extended to the nonlinear case with time-varying delays (Bekiaris-Liberis & Krstic, 2012). Consider the following nonlinear TDS:

$$\dot{X}(t) = f(X(t), U(t - h(t))) = f(X(t), U(\phi(t))) \quad (30)$$

with bounded time-varying delay  $h(t)$  satisfying  $|\dot{h}(t)| < 1$ . Suppose that there exists an uniformly bounded controller  $U(t) = \kappa(t, X(t))$  that renders the delay-free version of (30) GUAS. In addition, one assumes that the perturbed delay-free system  $\dot{X}(t) = f(X(t), \kappa(t, X(t))) + \omega(t)$  is ISS with respect



to the disturbance  $\omega(t)$ . First, introducing the following infinite-dimensional PDE terms:

$$\begin{aligned} u(x, t) &= U(\phi(t + x(\phi^{-1}(t) - t))), & \text{with } u(0, t) &= U(\phi(t)) = U(t - h(t)), \\ p(x, t) &= P(\phi(t + x(\phi^{-1}(t) - t))), & \text{with } p(1, t) &= P(t) \triangleq X(\phi^{-1}(t)), \\ \pi(x, t) &= \frac{1 + x \left( \frac{d(\phi^{-1}(t))}{dt} - 1 \right)}{\phi^{-1}(t) - t}, & r(x, t) &= t + x(\phi^{-1}(t) - t), \end{aligned} \quad (31)$$

with  $\phi^{-1}(t)$  defined in Table 1. Hence, the predictive control law  $U(t) = \kappa(\phi^{-1}(t), P(t))$  and the following invertible backstepping transformation:

$$w(x, t) = u(x, t) - \kappa(r(x, t), p(x, t)), \quad (32)$$

turn the original nonlinear TDS (30) into the following ODE-PDE coupling systems:

$$\Sigma_u : \begin{cases} \dot{X}(t) = f(X(t), u(0, t)), \\ u_t(x, t) = \pi(x, t)u_x(x, t), \\ u(1, t) = U(t), \end{cases} \quad \Sigma_w : \begin{cases} \dot{X}(t) = f(X(t), \kappa(t, X(t)) + w(0, t)), \\ w_t(x, t) = \pi(x, t)w_x(x, t), \\ w(1, t) = 0. \end{cases} \quad (33)$$

Note that the asymptotic stability of the target system  $\Sigma_w$  can be guaranteed by carefully conducting a Lyapunov analysis, then the convergence results of the original system can be derived from the stability of the target system  $\Sigma_w$  and the boundedness of the inverse transformation  $(X, w) \mapsto (X, u)$ . Summarising the aforementioned analysis, the predictor-based control in the PDE form can be determined by the following procedures:

- rewriting the original TDS into the coupled ODE-PDE system  $\Sigma_u$ ;
- finding an invertible backstepping transformation  $(X, u) \mapsto (X, w)$  that leads to a GUAS target system  $\Sigma_w$ ;
- computing the control law  $U(t) = u(1, t)$  according to the PDE transformation, then analysing the closed-loop stability of the original system.

In the sequel, one recalls the existing literature on the predictor-based control in the PDE form of various TDSs. The predictor-based control of LTI systems under constant input delays, parameter uncertainties, and external disturbances was systematically studied by (Bresch-Pietri, 2012); the output-feedback controller design was considered in this paper as well. The ISS properties of the robust predictor-based controller for perturbed LTI multi-input systems with distinct constants delays are analyzed in (Cai, Bekiaris-Liberis, & Krstic, 2019). In (Krstic, 2010b), the compensation for time-varying input delays of LTI systems via the PDE approach was investigated for the first time, this paper also proposed a solution to the dual problem, *i.e.* observing the current state  $X(t)$  from the delayed output  $Y(t) = CX(\phi(t))$ . Thereafter, the predictor-based control technique for LTI systems under distributed input delays was developed in (Bekiaris-Liberis & Krstic, 2011), and this method was recently upgraded in (Zhu, Krstic, & Su, 2020) with the consideration of model uncertainties. The aforementioned methods focus on the control of linear TDSs, whereas the following references are interested in the predictor-based controller design for nonlinear TDSs. The PDE-based controller design methods for single-input (*i.e.*  $U(t - h) \in \mathbb{R}$ ) and multi-input (*i.e.*  $U_i(t - h_i) \in \mathbb{R}$ ) nonlinear TDSs were proposed in (Krstic, 2010a; Bekiaris-Liberis & Krstic, 2017), respectively. In (Bekiaris-Liberis & Krstic, 2012), predictor-based control techniques were proposed to stabilise conventional nonlinear TDSs (30) and nonlinear integrators with time-varying delays in the states and the input. The local stabilisation of nonlinear TDSs with state-dependent time-varying input delays was considered in (Bekiaris-Liberis, Jankovic, & Krstic, 2012; Bekiaris-Liberis & Krstic, 2013a), the time-delay in (Bekiaris-Liberis et al., 2012) depends on the current state  $X(t)$  while the delay in (Bekiaris-Liberis & Krstic, 2013a) relates to the delayed state  $X(\phi(t))$ .

In addition, for TDSs with time-varying delays, if the inverse function  $\phi^{-1}(t)$  is uncomputable, the approximated prediction horizon  $\phi^{-1}(t) \approx t + h(t)$  was utilised in (Bresch-Pietri, 2012; Bresch-Pietri, Mazenc, & Petit, 2018, Chapter 10) for designing the PDE-based controllers, which was similar to the ODE-based method (Léchappé et al., 2018). Furthermore, the readers may refer to (Krstić et al.,

1995; Bekiaris-Liberis & Krstic, 2013b) for more details about the backstepping controller design, the PDE-based delay compensation method, and the stabilisation of nonlinear TDSs under nonconstant delays, respectively.

### 3.2. Predictor-based control in the PDE form of systems with uncertain time-delays

Similar to Subsection 2.3, this subsection elaborates the PDE-based analysis on the delay-robustness of predictor-based controllers. In (Krstic, 2008), the condition on the constant delay mismatch was derived for preserving the exponential stability of LTI systems with constant input delays. This paper also put forward a discussion on the different sensitivities to the overcompensated/underestimated delays: the predictor-based controller could perform a better endurance to delay mismatches when the approximated delay is smaller than the actual one. Hereafter, the PDE-based controller design and stability analysis were proposed in (Krstic, 2008) for LTI systems with constant state delay and input delay; the closed-loop stability could be sustained if one of the delays was subject to a sufficiently small constant mismatch. An enhanced version of (Bresch-Pietri & Petit, 2014) was considered in (Bresch-Pietri, Petit, & Krstic, 2015) for stabilising forward complete nonlinear TDSs under uncertain constant delays in the input and the state. In (Bekiaris-Liberis & Krstic, 2013c, 2013d), the constant-delay predictor was employed to deal with time-dependent and state-dependent delay uncertainties of forward complete nonlinear TDSs. It was proved in (Bekiaris-Liberis & Krstic, 2013c, Theorem 1) that the robust controller could lead to an exponentially stable closed-loop system if the magnitudes of the delay uncertainty and its partial derivatives were small enough.

Compared with the ODE-based approaches presented in Subsection 2.3, the PDE-based methods commonly result in a more sophisticated stability analysis. In turn, the PDE transformation can offer the opportunity to cope with nonlinearity and state-dependent delay uncertainty, which were rarely concerned by the literature outlined in Subsection 2.3.

### 3.3. Adaptive backstepping methods of TDSs with unknown time-delay

In this subsection, the predictor-based control in the PDE form of systems with unknown time-delays is investigated. The main principle of the method is to treat the unknown time-delays as unknown parameters of the coupled ODE-PDE system, then stabilise the system through an adaptive backstepping controller. This method is firstly involved in (Krstic & Bresch-Pietri, 2009; Bresch-Pietri & Krstic, 2010) for the stabilisation of (1), in which the input delay is unknown, but its upper bound  $\bar{h}$  is supposed to be known. The core methodology of the adaptive backstepping predictor-based control is explained subsequently.

Denoting  $\hat{h}(t)$  as the online estimation of the unknown input delay  $h$ , then (28) and its inverse transformation are modified as:

$$\begin{aligned} w(x, t) &= u(x, t) - K \left[ e^{A\hat{h}(t)x} X(t) + \hat{h}(t) \int_0^x e^{A\hat{h}(t)(x-y)} B u(y, t) dy \right], \\ u(x, t) &= w(x, t) + K \left[ e^{(A+BK)\hat{h}(t)x} X(t) + \hat{h}(t) \int_0^x e^{(A+BK)\hat{h}(t)(x-y)} B w(y, t) dy \right]. \end{aligned} \quad (34)$$

The modified infinite-dimensional actuator states (34) leads to the following target system:

$$\Sigma_w : \begin{cases} \dot{X}(t) = (A + BK)X(t) + Bw(0, t), \\ h w_t(x, t) = w_x(x, t) - \tilde{h}(t)p(x, t) - h\dot{\hat{h}}(t)q(x, t), \\ w(1, t) = 0, \end{cases} \quad (35)$$

with  $\tilde{h}(t) = h - \hat{h}(t)$  and

$$\begin{aligned} p(x, t) &= K e^{A\hat{h}(t)x} [(A + BK)X(t) + Bw(0, t)], \\ q(x, t) &= \int_0^x K \left( I + A\hat{h}(t)(x - y) \right) e^{A\hat{h}(t)(x-y)} B u(y, t) dy + K e^{A\hat{h}(t)x} X(t). \end{aligned}$$

The next step is to design the adaptation law of  $\hat{h}(t)$  that makes the closed-loop system (35) GUAS. For instance, if the Lyapunov-Krasovskii functional is chosen such that

$$V(X, w, \tilde{h}) = h \ln \left[ 1 + X^T(t)PX(t) + \int_0^1 (1+x)w^2(x, t)dx \right] + \frac{b}{\gamma} \tilde{h}^2(t) \quad (36)$$

then the following adaptation law can render  $\dot{V}$  negative semidefinite (Krstic & Bresch-Pietri, 2009, eq. (24)):

$$\dot{\hat{h}}(t) = \text{Proj}_{[0, \bar{h}]} \left\{ - \frac{\int_0^1 (1+x)w(x, t)p(x, t)dx}{1 + X^T(t)PX(t) + \int_0^1 (1+x)w^2(x, t)dx} \right\}, \quad (37)$$

where  $\text{Proj}_{[0, \bar{h}]}(\cdot)$  refers to the standard projector (Krstić et al., 1995, Appendix E) on interval  $[0, \bar{h}]$ . Finally, the global stability/convergence results of  $X(t)$  can be derived by employing Barbalat's Lemma given for instance in (Tao, 1997). Therefore, the adaptive backstepping predictor-based controller design in PDE form can be split into the following steps:

- converting the original TDS (1) into the ODE-PDE form, *i.e.*  $\Sigma_u$ ;
- in (28), replacing the unknown delay  $h$  by the approximation  $\hat{h}(t)$ , then recalculating the hyperbolic transport PDE of the target system (35);
- designing an appropriate adaptation law for parameter  $\hat{h}(t)$  to ensure the exponential stability of the target system  $(X, w)$  in the strict Lyapunov sense;
- determining the adaptive backstepping controller  $U(t) = u(1, t)$  based on (34) and (37).

The original PDE-based adaptive backstepping method (Krstic & Bresch-Pietri, 2009; Bresch-Pietri & Krstic, 2010) has been gradually extended to several control scenarios:

- (1) The first development is the resilience to multiple sources of instabilities, *e.g.* parameter variations, partial state knowledge. In (Bresch-Pietri & Krstic, 2009b, 2009a), the adaptive backstepping controller was designed for LTI systems subject to unknown input delays and parameter uncertainties: an additional parameter adaptation algorithm was applied to cope with the uncertain parameters and derive the GUAS properties. The output-feedback controller design was addressed in (Bresch-Pietri, Chauvin, & Petit, 2011b, 2012; Zhu, Krstic, & Su, 2017), and the input disturbance rejection problem was resolved in (Bresch-Pietri et al., 2012) by utilising a DOB-based adaptive backstepping controller.
- (2) The second improvement is on the infinite-dimensional state  $u(x, t)$ , which was supposed to be available by (Krstic & Bresch-Pietri, 2009; Bresch-Pietri & Krstic, 2010). Indeed, this hypothesis is fairly restrictive for numerous control systems in practice. In (Bresch-Pietri, Chauvin, & Petit, 2010, 2011a; Bresch-Pietri et al., 2011b, 2012; Zhu et al., 2017) the following input observer

$$\begin{aligned} \hat{u}(x, t) &= U \left( t + \hat{h}(t) \cdot (x - 1) \right) \\ \hat{h}(t)\hat{u}_t(x, t) &= \hat{u}_x(x, t) + \hat{h}(t)(x - 1)\hat{u}_x(x, t) \end{aligned} \quad (38)$$

was proposed to approximate the unmeasurable state  $u(x, t)$ . In exchange for relaxing this assumption, the global stability might be reduced to the local stability (Bresch-Pietri et al., 2010); the system also fails to track a reference trajectory since it can only be regulated at a set-point (Zhu et al., 2017).

- (3) The third enhancement lies in the methodologies of the controller design/stability analysis. In (Zhu, Su, & Krstic, 2015; Zhu et al., 2017), several techniques were employed to facilitate the stability analysis, *i.e.* introducing Kreisselmeier-filters to estimate the unmeasurable ODE states and discarding the nonlinear damping terms.
- (4) Finally, the control framework has been extended for stabilising larger classes of control systems with unknown constant time-delays: LTI multi-input systems with distinct delays (Zhu, Krstic, & Su, 2018), LTI systems with distributed delayed inputs (Zhu et al., 2020), Reaction-Diffusion PDEs (Wang, Qi, & Diagne, 2021), Reaction-Advection-Diffusion PDEs (Wang, Diagne, & Qi, 2021). Besides, the PDE-based control framework and a neural-network-based delay estimator

were combined in (Chakraborty, Mehta, Doucette, & Dixon, 2017) to accomplish the ultimately bounded tracking control of nonlinear systems subject to matched perturbations and unknown time-varying delays.

### 3.4. Section review

This section surveys the PDE version of the predictor-based controller, whose convenience is the complete/direct stability analysis of the whole system, including the infinite-dimensional actuator state, by virtue of the transport PDE that reveals the nature of the time-delays. The main properties of this approach are summarised as follows:

- **Advantages:** Different from the model reduction (Artstein, 1982) that uses the state prediction  $X \mapsto Z$  for stability analysis, the PDE-based approach proposes a comprehensive state transformation  $(X, u) \mapsto (X, w)$  which can directly derive the stability of the original state  $X$ . Hence, the PDE-based method is more powerful to tackle nonlinearities and state-dependent delays. Furthermore, the PDE-based control scheme (28) offers the possibility to design an inverse-optimal dynamic controller (Krstic, 2008) with respect to the cost functional:  $J \geq \int_0^\infty (\mu \|X(s)\|^2 + \mu \|U(s)\|^2 + \|\dot{U}(s)\|^2) ds$ .
- **Drawbacks:** The adaptive backstepping method is nearly the most effective way to deal with unknown time-delays in theory, but this method may lead to high computation complexity. Indeed, the control synthesis cannot be directly computed in the explicit coordinate  $(X, u)$ , and the whole control algorithm contains three integral terms.

#### 4. Safe implementation and integration-free predictor-based control

As mentioned in (Van Assche, Dambrine, Lafay, & Richard, 1999), the numerical implementation of the integral term in (3) may destabilise the TDS since one intends to replace an infinite-dimensional term with finite sums. Several researchers have deeply analysed the numerical issues and proposed the safe implementation techniques that stabilise the digital closed-loop system, the main results of them are explicated in Subsection 4.1. Besides, several methods are dedicated to eliminating the integral term from the predictor-based controller, the so-called “integration-free predictor-based control” methods could be classified into the following aspects:

- **Truncated predictor-based control:** the aim of this method is to study the condition when one can safely discard the integral term while maintaining the closed-loop stability;
- **Observation-predictor-based control:** this technique is dedicated to developing an appropriate observer (several sequential observers) that estimates the state prediction, the output of the observers is utilised to design a finite-dimensional control law;
- **Discrete predictor-based control:** with this method, the continuous-time TDS is discretised, then a sampled-data predictor-based controller is proposed to stabilise the system.

Subsequently, the three aforementioned integration-free predictor-based controllers are summarised and compared in Subsections 4.2–4.4.

##### 4.1. Implementation of predictor-based controllers

The authors of (Van Assche et al., 1999) revealed the numerical issue in the online implementation of predictor-based controllers for the first time. As a matter of fact, the integral term

$$v(t) \triangleq \int_0^h e^{A(t-s)} BU(s) ds \quad (39)$$

in (3) cannot be perfectly computed on a digital computer, and inappropriate numerical computation may lead to instability. For instance, the simulation results given in (Van Assche et al., 1999, Section 3) exhibited that the Simpson rule cannot retain the closed-loop stability even for a very small integration step; the same issue was found in (Santos & Mondié, 2000) for the trapezoidal rule. The above phenomena were explicated in (Engelborghs, Dambrine, & Roose, 2001; Zhong, 2004; Michiels, Mondié, & Roose, 2003; Leonard & Abba, 2011): *i.e.* the strict properness of the integral term

$$Y(s) \cdot \left( \frac{1 - e^{-sh/N}}{s} \right) = \mathcal{L} \left( \int_0^{h/N} y(t - \tau) d\tau \right) \quad (40)$$

would be lost when it was approximated by numerical approaches through quadrature rule. In particular, the analysis of (Engelborghs et al., 2001) provided that the numerical issue could arise when the equivalent neutral functional differential equation (Hale & Lunel, 2013) has unstable difference part. Afterward, it was indicated in (Leonard & Abba, 2011) that the backward rectangle rule and the trapezoidal rule could establish safe implementations, whereas the Simpson rule might induce two supplementary zeros when approximating the integral term, one of which gave rise to the existence of an unstable pole in the digital closed-loop system.

According to the analysis mentioned above, two different approaches are possible to deal with the numerical issue: reducing the numerical approximation error or modifying the control law by studying the properties of the digital closed-loop system. Recall the analysis given in (Engelborghs et al., 2001, Section III), the unstable poles introduced by the numerical computation bring in high-frequency behaviors to the digital closed-loop system since they always have comparatively large imaginary parts. Thus, the destabilising effects caused by the numerical approximation (3) can be attenuated by a low-pass filter (Mondié & Michiels, 2003) as follows:

$$\dot{Z}(t) = A_f Z(t) + B_f \cdot T_s \left[ e^{Ah} X(t) + \frac{1}{2} U(t) + \sum_{i=1}^{N-1} e^{iAT_s} U(t - iT_s) + \frac{1}{2} e^{Ah} U(t - h) \right], \quad (41)$$

with appropriate matrices  $(A_f, B_f)$ , the sampling period  $T_s$ , and the approximation step number  $N = h/T_s$ . Under the similar core idea, the spectrum properties of the digital closed-loop system were improved in (Zhong, 2004) by modifying the numerical integration frameworks in the  $s$ -domain and the  $z$ -domain; it was proved that the  $H_\infty$  norm of the approximation error would converge to zero if  $N$  tends towards  $+\infty$ . It is worthwhile to point out that the prediction scheme (41) was lately applied in (Juárez, Mondié, & Kharitonov, 2020; Mazenc & Fridman, 2014, 2016) for designing dynamic predictor-based controllers and dynamic sampled-data predictor-based controllers. Besides, a sampled-data approach was proposed in (Popescu & Rasvan, 2004) to modify the control law, which is able to stabilise the continuous-time system under a sufficiently small sampling period  $T_s$ . In (Bresch-Pietri et al., 2012), the combination of the trapezoidal method and a periodic reset was adopted to overcome the numerical issue. More recently, a novel method for implementing nonlinear predictor-based control law was addressed in (Karafyllis & Krstic, 2016), whose main benefit is the explicit estimation of the minimum allowable approximation step number  $N$ .

**Illustrative example.** Consider the predictor-based control of the scalar input-delay system:

$$\dot{X}(t) = X(t) + U(t - h) \quad (42)$$

under different numerical implementation methods, where the input delay is set to  $h = 2.0$ s. For given feedback gain  $K = -7$  and integration step  $N = 40$ , the control law based on the Trapezoidal rule reads as:

$$U_T(t) = -K \left[ e^h X(t) + \frac{h}{N} \left( \frac{1}{2} U(t) + \sum_{i=1}^{N-1} e^{\frac{i}{N}} U(t - \frac{i}{N}) + \frac{1}{2} e U(t - h) \right) \right], \quad (43)$$

the Simpson rule-based digital control law satisfies that

$$U_S(t) = -K \left[ e^h X(t) + \frac{h}{3N} \left( U(t) + \sum_{i=1}^{N/2} 4e^{\frac{2i-1}{N}} U(t - \frac{2i-1}{N}) + \sum_{i=1}^{N/2-1} 2e^{\frac{2i}{N}} U(t - \frac{2i}{N}) + e U(t - h) \right) \right], \quad (44)$$

and the safe implementation could be computed by:

$$\dot{U}_s(t) = -5U_s(t) - 5K \left[ e^h X(t) + \frac{h}{N} \left( \frac{1}{2} U(t) + \sum_{i=1}^{N-1} e^{\frac{i}{N}} U(t - \frac{i}{N}) + \frac{1}{2} e U(t - h) \right) \right]. \quad (45)$$

The initial conditions of (42) are chosen such that  $X(0) = 1$ ,  $U_i(\theta) = -1.1312$ , for  $i \in \{T, S, s\}$ ,  $\theta \in [-2, 0]$ , and the step size of the solver is set to  $T_s = 0.001$ s.

The simulation results depicted in Figure 5 illustrate the discussions of this subsection. The Simpson

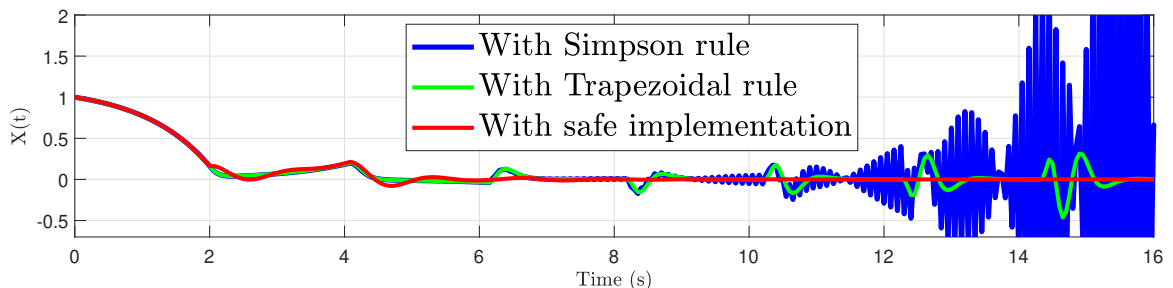

Figure 5.: Predictor-based control of the scalar system (42) under different implementation methods.

rule visibly leads to an unstable closed-loop system, and the Trapezoidal rule can neither preserve the stability/boundedness as time grows. However, the safe implementation technique (45) successfully overcomes the numerical issues by virtue of the low-pass filter  $F(s) = \frac{5}{s+5}$ , which emphasises the effectiveness of the approach.

#### 4.2. Truncated predictor-based controllers of systems with known/unknown time-delays

The truncated predictor-based control (Zhou, 2014b) develops a finite-dimensional controller for a class of TDSs with long time-delays. The main principle of this method is to design a time-varying gain  $K(\gamma, t)$  that makes the integral term ignorable, thus the TDS can be stabilised by the truncated controller if some specific conditions are fulfilled.

Consider the control of (1) by the truncated predictor-based controller, if all eigenvalues of  $A$  are on the imaginary axis, then there exists a symmetric positive definite matrix  $P(\gamma)$  such that the following ARE is satisfied:

$$A^T P(\gamma) + P(\gamma)A - P(\gamma)BB^T P(\gamma) = -\gamma P(\gamma). \quad (46)$$

Finally, for sufficiently small  $0 < \gamma < \gamma^*$ , system (1) can be stabilised by the finite-dimensional control law:

$$U(t) = -B^T P(\gamma)e^{Ah} X(t). \quad (47)$$

Truncated predictor-based control (46)–(47) also deals with a class of linear parameter-varying (LPV) systems with time-varying delays. In this case,  $A(t)$  is supposed to be a periodic matrix whose characteristic multipliers are all contained in the unit circle. Next, the ARE (46) should be replaced by the following DRE:

$$-\dot{P}(t) = A^T(t)P(\gamma, t) + P(\gamma, t)A(t) - P(\gamma, t)B(t)B^T(t)P(\gamma, t) + \gamma P(\gamma, t), \quad (48)$$

and the modified control law reads as

$$U(t) = -B(\phi^{-1}(t))^T P(\gamma, \phi^{-1}(t)) \Phi_A(\phi^{-1}(t), t) X(t), \quad (49)$$

where  $\phi(t)$  and  $\Phi_A(\cdot, \cdot)$  are defined in Table 1. Thereafter, the general principles of truncated predictor-based control were applied to design a novel integration-free method named “pseudo predictor-based controller” (Zhou, 2014a; Zhang, Zhou, & Michiels, 2021), in which the closed-loop dynamic was utilised to replace the open-loop system equation for designing the control law.

Besides, the truncated predictor-based controller can be extended to the stabilisation of linear systems subject to unknown time delays. Consider again the control of system (1) in which  $h$  is unknown but its upper bound is available. It is proved in (Wei & Lin, 2019b, 2019a) that the control synthesis (46)–(47) can stabilise the system by using a time-varying parameter  $\gamma(t) = m/\hat{\tau}(t)$  with the following properties:

- the positive constant  $m$  is sufficiently small;
- the function  $\hat{\tau}(t) > 0$  is an increasing function with a finite bound.

The core idea of this work is the use of low gain feedback (Lin, 1999). While the decreasing parameter  $\gamma(t)$  enters into the interval  $\gamma(t) \in (0, \gamma^*)$ , by updating the parametric Lyapunov equation, the closed-loop stability criteria should be eventually satisfied.

The truncated predictor-based controllers have drawn the attention of researchers for the last decade. The truncated predictor-based control of LTI systems with time-varying input delays was extensively investigated by (Zhou, Lin, & Duan, 2012); the output-feedback and input saturation problems were considered in this paper as well. In (Zhou & Lin, 2014b), the authors designed control laws for a class of polynomial unstable LPV systems under multiple time-varying input delays. The regulation of feedforward/non-feedforward nonlinear chain of integrators with unknown time-varying input delay was addressed in (Koo & Choi, 2016b, 2016a), the closed-loop stability could be established as long as the dynamic parameter evolves to a suitable level; the main results of them are extended to the control of delayed triangular nonlinear systems with uncertain/unknown time-varying input delay or/and state delay (Koo & Choi, 2017, 2018; Oh & Choi, 2020; Koo & Choi, 2021).

Remind that all of the above references are based on the fact that all eigenvalues of  $A$  are on the imaginary axis, the linear part of the nonlinear integrator discussed in (Koo & Choi, 2016b, 2016a, 2017, 2018; Oh & Choi, 2020; Koo & Choi, 2021) also satisfies this property, whereas the following methods tried to relax this constraint. In (Wei & Lin, 2015, 2017b), the delay-independent truncated

predictor-based controllers were proposed to stabilise unstable LTI systems with a single time-varying input delay for the first time; it was proved that the system could be stabilised if the time delay is below a certain upper bound. The core idea of the delay-independent truncated predictor-based control was applied in (Wei & Lin, 2016, 2017a, 2018) to deal with the state-feedback control of LTI systems under multiple constant/time-varying delays and the output-feedback problem, respectively. In (Ding & Lin, 2014; Zuo, Lin, & Ding, 2016), the truncated predictor-based controllers were designed for Lipschitz nonlinear systems with constant/time-varying input delays, respectively; the stability of these approaches could be satisfied by checking the feasibility of several LMIs depending on the time delay, or the delay upper bound, and the system parameters. Nevertheless, without the purely imaginary poles, the capacity of compensating for arbitrarily long time-delay is lost by these methods, which exhibits a compromise to different sources of instability (open-loop poles, time delays).

Recently, several digital truncated predictor-based controllers were proposed. In (Zhou, Sang, & Lin, 2013), the authors developed a sampled-data truncated predictor-based controller for LTI systems with a single constant input delay, which leads to the exponential stable closed-loop system like the continuous-time ones. In (Zhou, Li, & Lin, 2013), the continuous-time approach was extended to the control of LTI discrete-time systems subject to a single constant input delay and input saturation; this technique was completed in (Yang & Zhou, 2017) for dealing with multiple time-varying input delays. In (Wei & Lin, 2020, 2021), the output-feedback truncated predictor-based controllers are proposed for LTI discrete-time systems with single known/unknown time-varying input delay. In (Xie, Wei, & Lin, 2020), the event-triggered mechanism was combined with the truncated predictor-based controller for reducing the computational load when stabilising an LTI TDS with a time-varying input delay.

#### 4.3. Observation-predictor-based control of systems with time delays

The main drawback of the truncated predictor-based controller presented in Subsection 4.2 is the requirements on the original system, *e.g.* the poles/characteristic multipliers of matrix  $A/A(t)$ , so it is difficult to stabilise exponentially unstable systems. This subsection introduces an alternative integration-free predictor-based controller for unstable systems, whose motivation is to estimate the state prediction by observation techniques, rather than directly compute it.

For system (1), define  $e(t) = Z(t) - X(t+h)$ , the following predictive observer (Besançon et al., 2007):

$$\dot{Z}(t) = AZ(t) + BU(t) + L[Z(t-h) - X(t)] \quad (50)$$

leads to the error dynamics:  $\dot{e}(t) = Ae(t) + Le(t-h)$ . Therefore, if the input delay  $h$  is sufficiently small, then the convergence  $\lim_{t \rightarrow \infty} Z(t) = X(t-h)$  can be established by well tuning  $L$  via delay-dependent approaches (Fridman, 2014, Section 3.3.1), and system (1) can be stabilised by the control law  $U(t) = KZ(t) \approx KX(t+h)$ .

The dynamic observation-prediction (50) is the key to this method, which approximates the future state  $X(t+h)$  by using a finite-dimensional approach without causing numerical issues. Next, the method of (50) is extended to sequential observers (Najafi, Hosseinnia, Sheikholeslam, & Karimadini, 2013) for stabilising systems with long time-delays. The core idea is to divide the long delay  $h$  into some sufficiently small pieces  $\bar{h} = h/r$ ,  $r \in \mathbb{N}_+$  that verify the delay-dependent convergence condition for (50), then designing the following chain of observers to estimate  $X(t+h)$ :

$$\begin{cases} \dot{Z}_1(t) &= AZ_1(t) + BU(t - (r-1)\bar{h}) + L_1 [Z_1(t - \bar{h}) - X(t)], \\ &\vdots \\ \dot{Z}_i(t) &= AZ_i(t) + BU(t - (r-i)\bar{h}) + L_i [Z_i(t - \bar{h}) - Z_{i-1}(t)], \\ &\vdots \\ \dot{Z}_r(t) &= AZ_r(t) + BU(t) + L_r [Z_r(t - \bar{h}) - Z_{r-1}(t)]. \end{cases} \quad (51)$$



In (51), the convergence results  $\lim_{t \rightarrow \infty} Z_1(t) = X(t + \bar{h})$ ,  $\lim_{t \rightarrow \infty} Z_i(t) = Z_{i-1}(t + \bar{h})$ ,  $i \in \{2, \dots, r\}$  can be ensured by well selecting matrices  $L_i$ 's, which further yield  $\lim_{t \rightarrow \infty} Z_r(t) = X(t + h)$ . Finally, the control law  $U(t) = KZ_r(t)$  is able to stabilise system (1) with long input delay. Different from the truncated predictor-based control referred in Subsection 4.2, the sequential observation-predictor-based control deals with unstable systems with long time delays thanks to the sequential predictive observation scheme (51).

The observation-predictor-based control technique was gradually developed for stabilising different types of systems subject to different time delays. The  $H_\infty$  control version of (Najafi et al., 2013) was proposed in (Najafi, Sheikholeslam, Wang, & Hosseinnia, 2014) to achieve prescribed robustness indexes against model uncertainties and external disturbances. Hereafter, the sequential observation-based control scheme (51) was utilised in (Cacace, Germani, & Manes, 2014; L  chapp  , Moulay, & Plestan, 2016) for stabilising LTI systems with long time-varying input delays. The stabilisation of LPV systems with time-varying input delays was concerned in (Mazenc & Malisoff, 2016), and the robustness analysis of this approach was provided in (Mazenc & Malisoff, 2017a). In (Malisoff & Mazenc, 2018), the sequential observation-predictor-based controller was designed for a class of LPV systems with constant delays in the input and the state, where the input delay was supposed to be an integer multiple of the state delay.

Note that the control schemes (50)–(51) can be extended to the nonlinear version. In (Karafyllis & Krstic, 2013b; Jo, Choi, & Lim, 2014; Cacace, Conte, Germani, & Pepe, 2016), the observation-predictor-based controller were designed to regulate a class of particular triangular nonlinear systems subject to uncertain time-varying delays. The input-to-state stability of general Lipschitz nonlinear systems with constant input delays was considered in (Mazenc & Malisoff, 2017b) at the first time. Next, an extended-state predictive observer similar to (50) was proposed in (Sanz, Garc  a, Fridman, & Albertos, 2017; Sanz, Garcia, Fridman, & Albertos, 2018) to solve the control problems of nonlinear systems under time-varying input delays. In (Sanz, Garc  a, Fridman, & Albertos, 2020), the sequential version of (Sanz, Garc  a, et al., 2017) was combined with a disturbance compensation strategy in order to reduce the conservatism and improve the robustness simultaneously.

In the last few years, the researchers paid more attention to the observation-predictor-based control of TDSs possessing digital manners, *i.e.* discrete-time TDSs, sampled-data TDSs, NCSs. The discrete-time versions of (51) were analysed in (Mazenc & Malisoff, 2020b; Mazenc, Malisoff, & Bhogaraju, 2020) to compensate for the constant input delays and time-varying output delays, respectively. (Mazenc & Malisoff, 2018, 2020a) investigated the control of sampled-data linear systems with constant input delays: (Mazenc & Malisoff, 2018) firstly dealt with perturbed LTI systems and (Mazenc & Malisoff, 2020a) proposed a control solution to perturbed LPV systems accompanying with experimental results on a DC motor. In (Karafyllis, Malisoff, Mazenc, & Pepe, 2016, pp.43-60), the sequential observation-predictor-based controller was adopted to stabilise Lipschitz nonlinear sampled-data systems with constant input and output delays under aperiodic sampling mechanisms, where an inter-sample predictor was added to improve the estimation performances. More recently, in (Katz & Fridman, 2021; Zhu & Fridman, 2021), the dynamic predictive observers (51) were involved to stabilise parabolic PDE systems and design event-triggered control laws for NCSs with uncertain constant transmission delays, respectively.

Besides, the core idea of this method was also applied in (Wang, Liu, & Cai, 2009; Ahmed-Ali, Cherrier, & Lamnabhi-Lagarrigue, 2012) for estimating the current states of linear/triangular nonlinear systems by using the delayed output information.

#### 4.4. Discrete predictor-based controller

Another way to overcome the numerical issue caused by the infinite-dimensional term is to discretise the control system, which transforms the continuous-time integration to a finite sum thanks to the properties of the digital controller; this method is known as the ‘‘discrete predictor-based control’’. A brief example is presented subsequently to describe the general principles of this approach. Consider the discretisation of (1) under a constant sampling period  $\Delta > 0$ , then define  $N = \lfloor h/\Delta \rfloor$ ,  $h_1 = h - N\Delta$ ,  $X[k] \triangleq X(k\Delta)$ , and  $U[k] \triangleq U(k\Delta)$ . Therefore, the following discrete-time system can be derived from

the original system (1):

$$X[k+1] = \bar{A}X[k] + \bar{B}_1U[k-N] + \bar{B}_2U[k-N-1] \quad (52)$$

with  $\bar{A} = e^{A\Delta}$ ,  $\bar{B}_1 = \int_{h_1}^{\Delta} e^{A(t-s)}Bds$ , and  $\bar{B}_2 = \int_0^{h_1} e^{A(t-s)}Bds$ . By constructing the extended state  $X_{ext}[k] = [X^T[k] \ U^T[k-1] \ \cdots \ U^T[k-N] \ U^T[k-N-1]]^T$ , the discrete-time system (52) equivalently writes as the following delay-free system:

$$X_{ext}[k+1] = \underbrace{\begin{bmatrix} \bar{A} & 0 & \cdots & \bar{B}_1 & \bar{B}_2 \\ 0 & 0 & \cdots & 0 & 0 \\ 0 & I_m & \cdots & 0 & 0 \\ \vdots & \vdots & \ddots & \vdots & \vdots \\ 0 & 0 & \cdots & I_m & 0 \end{bmatrix}}_{\mathcal{A}} X_{ext}[k] + \underbrace{\begin{bmatrix} 0 \\ I_m \\ 0 \\ \vdots \\ 0 \end{bmatrix}}_{\mathcal{B}} U[k]. \quad (53)$$

Hence, by making  $\mathcal{A} + \mathcal{B}\mathcal{K}$  Schur stable, the discrete-time predictive control law  $U[k] = \mathcal{K}X_{ext}[k]$  leads to the exponential stability of (52)–(53). Moreover, the stability of the original TDS (1) can be obtained if the conditions in (Francis & Georgiou, 1988, Section VIII) are fulfilled. With this method, the state prediction can be achieved by iterating the discrete-time equation (52), rather than computing the continuous-time integration (3). Thus, the discrete predictor-based controller can cope with long time-delays through a finite-dimensional approach.

The discrete predictor-based controller has been widely applied in discrete-time systems and sampled-data systems. One of the first articles to deal with the design of discrete predictor for continuous-time systems is (Lozano, Castillo, Garcia, & Dzul, 2004), in which the extended prediction scheme was introduced to stabilise LTI systems with nearly constant time delays, *i.e.* the delay uncertainty is within one sampling period. The main results in (Lozano et al., 2004) were illustrated by the yaw control of a quadrotor. Hereafter, the authors of (García, Castillo, Lozano, & Albertos, 2006) relaxed the constraint on the delay variation by solving a delay-dependent LMI, and the control scheme was proved to be more robust than the one of (Lozano et al., 2004). In (García, González, Castillo, Lozano, & Albertos, 2010), the discrete predictor-based controller was designed for a class of linear TDSs with constant input delay and uncertain output delay, and the resulting technique was validated by experimental results in (González, 2012). The predictor-based control of discrete-time systems under a single time-varying input delay was developed in (González, Sala, & Albertos, 2012; González, Sala, García, & Albertos, 2013), in which the CCL algorithm was involved to estimate the allowable bounds on the time-varying delay. The robustness in (González et al., 2012) was further improved in (González, 2013) with the consideration of model uncertainties. In (Hao, Liu, & Zhou, 2019), the discrete version of the observation-prediction method mentioned in Subsection 4.3 was investigated, and a robust predictive control scheme was proposed to deal with the output-feedback control of linear discrete-time systems under time-varying input delay and perturbations. The work of (González & García, 2021) tackled the same control problem as (Hao et al., 2019) with lower computation complexity; this method also allows the compensation for mismatched disturbances.

It is worthwhile to point out that the discrete predictor-based controller is also effective for NCSs, these methods will only appear in Subsection 5.1 for brevity.

#### 4.5. Section review

The first part of this section introduces the existing works on analysing and avoiding the numerical problems arising in the real-time implementation of the predictor-based controllers.

Next, this section reports the main approaches for eliminating the integral term from the predictor-based controller while guaranteeing the closed-loop stability. The truncated predictor-based controller studied the condition when the integration part could be neglectable. The dynamic observation-prediction technique implicitly estimates the state prediction without using any infinite-dimensional terms. The discrete predictor-based controller prevents the numerical problem by applying the discretisation and the piecewise-constant control law. As a conclusion, the advantages and disadvantages are below:

- **Truncated predictor-based controller:** the main feature of this method is the assumption on the open-loop poles/characteristic multipliers. Once the assumption is satisfied, the truncated predictor-based controller can stabilise the system through a low-complexity control framework that is less conservative on the delay variation. Conversely, if the open-loop system is exponentially unstable and the time delay is long, the truncated predictor-based controller may not achieve a good control performance.
- **Observation-predictor-based controller:** this approach utilises the observation technique to approximate the state prediction; it is possible to enlarge the allowable time delay by increasing the number of sub-observers. This method can be easily extended to deal with various nonlinear systems, but the control scheme often leads to conservatism on the delay variation due to the use of delay-dependent LMIs.
- **Discrete predictor-based controller:** thanks to the sampling-ZOH mechanism, the future state can be estimated by iterating the discrete-time equation, and the infinite-dimensional integration is no longer required. The discrete predictor-based controller has been broadly applied in numerous control applications. However, this method cannot readily cope with strong nonlinearity since the analytical solution to the system equation is difficult to obtain. To the best of the authors' knowledge, the predictor-based control of nonlinear discrete-time systems (Pepe, Pola, & Di Benedetto, 2017) with time-varying delays was only investigated by a few works, *e.g.* (Choi & Krstic, 2016; Cai, Liao, Liu, & Lin, 2017; Mattioni, Monaco, & Normand-Cyrot, 2018).

## 5. Applications of predictor-based control

After introducing the theoretical analysis on the predictor-based controller, this section is interested in the practical applications of this method. The extensions of the predictor-based control to NCSs and MASs are introduced in Subsections 5.1 and 5.2, respectively. Hereafter, the predictor-based control of robotic systems is addressed in Subsection 5.3, which highlights the effectiveness of this method in control engineering.

### 5.1. Predictor-based control for networked control systems

An NCS is a special type of TDSs, in which the system plant and the controller are no longer physically connected but communicate with each other through wireless networks (Zhang et al., 2020). In NCSs, the sampled state/output measurements of the plant are transmitted to the controller over a sensor-to-controller network, the controller then computes the digital control law and sends it back to the plant through a controller-to-actuator network. The distributed networked-based set-up provides several practical benefits: flexibility, low cost, and easy maintenance (Liu, Selivanov, & Fridman, 2019), but this framework brings in unreliable network-induced delays.

Similar to the control problems of continuous-time TDSs, a sampled static state/output-feedback con-

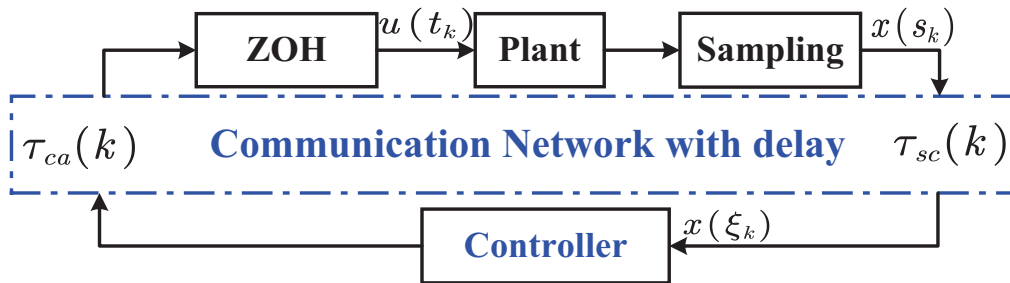

Figure 6.: Schematic of the control of NCSs with time-delays.

troller can stabilise NCSs under small enough transmission delays and fast enough sampling (Fridman, 2014, Chapter 7.5). If the network-induced delays are long, then the stability criteria of the above method will be difficult to satisfy. Hence, predictor-based control techniques are extended to the sampled-data version for stabilising NCSs with long transmission delays. In general, two different approaches can be applied to design predictor-based controllers for NCSs:

- **discrete-time method (Hu & Zhu, 2003; Cloosterman, Van de Wouw, Heemels, & Nijmeijer, 2009):** by discretising the original NCS, a discrete-time delay-free extended system is obtained, and the predictive sampled-data control law is discretely designed;
- **time-delay method (Selivanov & Fridman, 2016b, 2016a):** this method first regards the sampling, the ZOH, and the network-induced delays as a lumped piecewise-linear time-varying delay whose derivative equals 1, then it implements the continuous-time predictor-based controller and determines the maximum allowable inter-sampling interval that preserves the Lyapunov-Krasovskii stability.

In (Cloosterman et al., 2009), a comprehensive method was proposed for designing/analysing predictor-based controllers through the discrete-time approach, the compensation for time-varying delays is achieved by checking numerous LMIs. The discrete predictor-based control of NCSs with stochastic delays was investigated in (Hu & Zhu, 2003; Zhan, Du, & Fei, 2017) by applying optimal control techniques and switching gains, respectively. In (Yang & Zheng, 2019; L  chapp  , Moulay, Plestan, & Han, 2019), the discrete-time method was utilised to design event-triggered output-feedback predictor-based controllers for NCSs with constant network-induced delays, the work in (L  chapp   et al., 2019) also considered the quantization and provided an alternative low-dimensional scheme to compute the state prediction. The control technique of (L  chapp   et al., 2019) was extended to (Deng, L  chapp  , Zhang, et al., 2021) for stabilising a class of NCSs with time-varying delays and message rejection with packet disordering. In addition, the methods reported in (Zhan et al., 2017; Deng, L  chapp  , Zhang, et al., 2021) were verified by experimental results on the networked visual-servo inverted pendulum system

developed in (Du et al., 2020). In addition, the event-triggered predictor-based control of discrete-time NCSs under time-varying transmission delays and packet-dropouts was resolved in (Yang, Guo, Dai, & Xia, 2017), where a logical controller was applied to select the most suitable control law from a buffer consisting of several predictive control inputs based on different time horizons.

The time-delay method was involved in (Selivanov & Fridman, 2016b) for the design of event-triggered predictor-based controllers of NCSs under uncertain constant transmission delays, two control schemes were proposed to stabilise NCSs under continuous/sampled state measurements. A continuous-time Lyapunov-Krasovskii analysis proved that the NCSs will become exponentially stable if the MATI is small enough to render a delay-dependent LMI feasible. It is worthwhile to point out that this approach no longer suffers from the numerical issue since the integral term is a finite sum depending on the piecewise-constant control law. The main results of (Selivanov & Fridman, 2016b) were upgraded to (Selivanov & Fridman, 2016a) for stabilising LTI NCSs with uncertain constant delays and partial state knowledge. Besides, the trajectory-based stability analysis method (Mazenc & Malisoff, 2015) was involved in (Sun, Liu, Wem, & Wang, 2016) to design predictor-based controllers for a class of nonlinear NCSs with bounded time-delays and transmission protocols. Moreover, the authors of (Zhu & Fridman, 2019, 2020a, 2020c) considered the decentralized predictor-based control of large-scale systems with input delays, which can be regarded as the interconnections of multiple NCSs. Recently, to reduce the conservatism of (Selivanov & Fridman, 2016b, 2016a), the authors of (Zhu & Fridman, 2020b, 2021) proposed the sampled-data version of the observation-predictor-based control for LTI NCSs with parameter uncertainties, *i.e.* for the same MATI, the novel method (Zhu & Fridman, 2020b, 2021) can provide a longer MAD than the previous ones (Selivanov & Fridman, 2016b, 2016a; Zhu & Fridman, 2020c). Nevertheless, extending these methods to the predictor-based control of NCSs with strongly time-varying delays needs further development.

Note that both methods mentioned above, discrete-time and time-delay methods, can stabilise NCSs with long time-delays, each one has its own advantages. The time-delay method handles the variable sampling case, and it can readily describe the inter-sampling behaviors of NCSs, but it requires a fast enough sampling. On the contrary, the discrete-time method is usually utilised for NCSs under uniform sampling, but it deals with time-varying delays and offers less conservatism in the sense of MATI. Thus, to stabilise an NCS with long network-induced delays, the users can determine which method to use according to system properties and control objectives.

**Illustrative example.** Consider the networked predictor-based control of the linearised inverted pendulum system (Selivanov & Fridman, 2016b):

$$\dot{X}(t) = \underbrace{\begin{bmatrix} 0 & 1 & 0 & 0 \\ 0 & 0 & -mg/M & 0 \\ 0 & 0 & 0 & 1 \\ 0 & 0 & g/l & 0 \end{bmatrix}}_A X(t) + \underbrace{\begin{bmatrix} 0 \\ 1/M \\ 0 \\ -1/Ml \end{bmatrix}}_B U(t), \quad (54)$$

through time-delay and discrete-time approaches under parameter settings:  $M = 10\text{kg}$ ,  $m = 1\text{kg}$ ,  $l = 3\text{m}$ ,  $g = 10\text{m/s}^2$ . The sensor-to-controller and the controller-to-actuator delays are set to  $\tau_{sc} = \tau_{ca} = 0.2\text{s}$ . The controller and actuator are assumed to be event-driven, *i.e.* they take action as soon as the new data packets arrive. The sequence  $\{s_k\}_{k \in \mathbb{N}}$  represent the sampling instants of the sensor, and the sequences  $\{\xi_k\}_{k \in \mathbb{N}}$ ,  $\{t_k\}_{k \in \mathbb{N}}$  denote the execution instants of the controller and actuator, respectively. The predictor-based controller designed by the time-delay approach (Selivanov & Fridman, 2016b) reads as:

$$U(\xi_k) = K \left[ e^{A(\tau_{sc} + \tau_{ca})} X(s_k) + \int_{s_k - \tau_{ca}}^{\xi_k} e^{A(\xi_k - \theta)} B v(\theta) d\theta \right], \quad (55)$$

with  $K = [2 \quad 12 \quad 378 \quad 210]$  and

$$v(\xi) \triangleq \begin{cases} 0, & \xi < \xi_0, \\ U(\xi_k), & \xi \in [\xi_k, \xi_{k+1}). \end{cases} \quad (56)$$

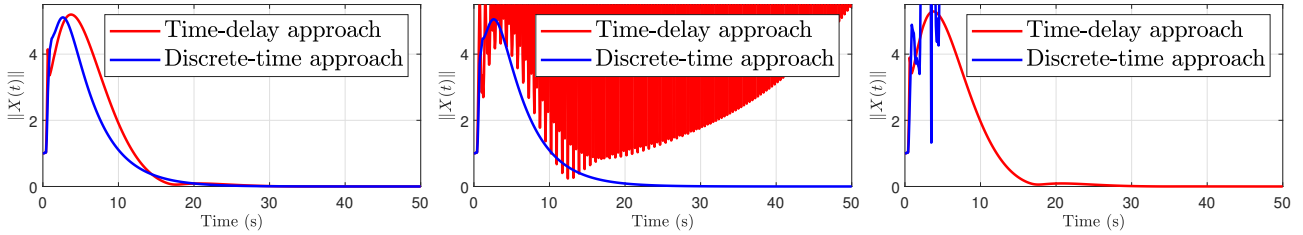

Figure 7.: Trajectories of (54) controlled by (55)–(56) and (57) with constant sampling period  $\Delta = 0.25\text{s}$  (left),  $\Delta = 0.37\text{s}$  (center) and with aperiodic sampling  $\Delta \in [0.20\text{s}, 0.35\text{s}]$  (right).

Next, one defines the extended discrete-time state as  $X_{ext}[k] = [X^T(s_k) \ U^T(\xi_{k-1}) \ U^T(\xi_{k-2})]^T$ ,  $N = \lfloor \frac{\tau_{sc} + \tau_{ca}}{\Delta} \rfloor$ ,  $h_1 = (\tau_{sc} + \tau_{ca}) - N\Delta$ , and matrices  $(\mathcal{A}, \mathcal{B})$  as in (53) for computing the discrete predictor-based controller (Léchappé et al., 2019) in the sequel:

$$U[k] = U(\xi_k) = \mathcal{K}X_{ext}[k], \quad \text{with} \quad \lambda(\mathcal{A} + \mathcal{B}\mathcal{K}) = \{e^{-0.25\Delta}, e^{-1.1\Delta}, e^{-1.4\Delta}, e^{-5\Delta}, e^{-6\Delta}, e^{-7\Delta}\}. \quad (57)$$

Thereafter, three numerical simulations are conducted to show the different advantages of the two approaches, where the step size of the solver is given as  $T_s = 0.001\text{s}$ .

The simulation results are presented in Figure 7. Firstly, Figure 7 (left) indicates that both methods can stabilise the NCS under a sufficiently small constant sampling period  $\Delta = 0.25\text{s}$  with similar overshoots and response times. Next, one examines if the closed-loop stability can be maintained by increasing the constant sampling period to  $\Delta = 0.37\text{s}$ ; Figure 7 (center) claims that the discrete-time approach can still stabilise the NCS, but the time-delay approach fails. Finally, the robustness of the two approaches to aperiodic sampling is compared, where the nominal sampling period  $\Delta = 0.20\text{s}$  is chosen to compute the discrete-time controller (57). Figure 7 (right) reveals that the time-delay approach yields better performance under the variable sampling scheme  $\Delta \in [0.20\text{s}, 0.35\text{s}]$ . Hence, the illustrative example confirms the aforementioned discussions of this subsection and highlights the different advantages of the two predictor-based control methods for NCSs.

## 5.2. Predictor-based control for multi-agent systems

Another crucial application of predictor-based controller is the consensus of MASs under long actuator or/and communication delays (Olfati-Saber & Murray, 2004), which is a vigorously growing but challenging topic in the control community for the last decades. Note that the non-predictive control protocol could attain the consensus only in the case that the time-delays are sufficiently small, which motivates the researchers to implement predictor-based control techniques in MASs. However, the conventional predictor-based control methods proposed in Section 2 can hardly deal with MASs since each agent in the network must predict the dynamics of the other agents that depend on their relative control signals over a time interval, which may lead to communication burdens and numerical issues. Therefore, the integration-free predictor-based control methods mentioned in Section 4 are more admissible in MASs.

In the sequel, one summarises the existing truncated predictor-based consensus control methods. The truncated predictor-based control was introduced in (Zhou & Lin, 2014a) to deal with LTI MASs with long input delays for the first time; this approach was further applied to LTI MASs with multiple constant/time-varying input delays in (Zhou & Cong, 2016; Chu, Yue, Dou, Xie, & Chu, 2021), respectively. In (Wang, Zuo, Lin, & Ding, 2016), the consensus of nonlinear Lipschitz MASs with constant input delays through truncated predictor-based control was concerned, where the Laplacian matrix was transformed into a real Jordan form for deriving the sufficient conditions to the global consensus. Moreover, an alternative idea was put forward in (Zhou & Cong, 2016; Liu, 2021) to build predictor-based controllers for MASs without causing the aforementioned problems. The principal convenience of this method is the pseudo predictor-based control technique (Zhou, 2014a) that employs the closed-loop dynamics for predicting the future states, rather than the open-loop ones that depend on the

knowledge about the neighbor agents. Furthermore, several references (Zhou, 2014b; Yan & Chen, 2019; Yang & Zhou, 2019; Wang, 2021) also showed their interests in the truncated predictor-based control of discrete-time high-order MASs under time-varying delays.

Coinciding with Subsection 4.2, the truncated predictor-based consensus control algorithms have the following properties:

- If the agents are polynomially unstable, *i.e.* with open-loop poles on the imaginary axis, then the consensus can be achieved under arbitrarily long but bounded time-delays.
- For exponentially unstable agents, it is possible to compute a MAD that establishes the consensus, which depends on the open-loop systems, the network topologies, and the prescribed convergence rate (Chu et al., 2021).

To remedy the drawbacks of the truncated predictor-based controllers, the discretisation of the whole MAS was considered in (Ponomarev, Chen, & Zhang, 2018) for the first time, it was verified that the discrete predictor-based controller could deal with exponentially unstable MASs with long constant/time-varying delays. In (González, 2021), a weighted event-triggered mechanism was put forward to improve the performances of such a distributed discrete predictor feedback framework. In (Jiang, Peng, Rahmani, Hu, & Wen, 2018; Liu, 2020), the observation-predictor-based controllers were proposed for continuous-time perturbed LTI MASs and discrete-time MASs with state and input delays, respectively. Hereafter, the observation-predictor-based consensus control of LTI MASs simultaneously subject to input delay and communication delay was tackled in (Jiang, Chen, & Charalambous, 2020).

Besides, the PDE-based approaches were recently employed to analyse the predictor-based control of MASs. In (Qi, Wang, Fang, & Diagne, 2019), the Reaction-Advection-Diffusion PDE-based modeling was introduced to describe the consensus problem in the 3D-space, next a boundary controller was proposed to deal with long time-delays and actuator constraints. Afterwards, (Huang & Ding, 2020) conducted a delay-robustness analysis to the consensus problems via predictor feedback, which was rarely studied by the existing literature. In (Huang, Ding, & Cao, 2020), the adaptive backstepping control scheme (Krstic & Bresch-Pietri, 2009) was applied to MASs with unknown input- and measurement delays for the first time; this method was further extended to (Huang & Ding, 2021a, 2021b) for coping with switching topologies and undirected graphs, respectively.

### 5.3. Predictor-based control for mechanical/robotic Euler-Lagrange systems

During the last decades, the remote control of mechanical/robotic systems has become a dominant research field of control engineering, whose main challenge contains nonlinearity, coupling, and delays induced by physical dead times, measurements and data communications. This subsection provides an investigation on the predictor-based control of retarded mechanical/robotic systems, which are mainly described by Euler-Lagrange equations.

In (Sharma, Bhasin, Wang, & Dixon, 2011), the model reduction of the following Euler-Lagrange system was investigated for the first time:

$$M(q(t))\ddot{q}(t) + V_m(q(t), \dot{q}(t))\dot{q}(t) + G(q(t)) + F(\dot{q}(t)) + d(t) = U(t - h) \quad (58)$$

with the inertia matrix  $M(q(t))$ , the Coriolis term  $V_m(q(t), \dot{q}(t))$ , the gravitational term  $G(q(t))$ , the friction term  $F(\dot{q}(t))$ , the external disturbance  $d(t)$ , and the delayed control input  $U(t - h)$ . To achieve the robust tracking control of a reference signal  $q_d(t) \in \mathbf{C}^3([0, \infty))$ , one focuses on the auxiliary variable:

$$r(t) = \dot{e}_{2a}(t) + \alpha_2 e_{2a}(t) + M(q)^{-1} \left[ \underbrace{U(t - h) - U(t)}_{e_a(t)} \right], \quad (59)$$

in which the tracking errors are defined as

$$e_{2a}(t) = \dot{e}_1(t) + \alpha_1 e_1(t), \quad e_1(t) = q_d(t) - q(t), \quad (60)$$

with  $\alpha_1, \alpha_2 > 0$ . Under the dynamic control law

$$\dot{U}(t) = k_a r(t) \quad (61)$$

where  $k_a$  should be tuned sufficiently small, the error system of  $z_a(t) = [e_1^T(t) \ e_{2a}^T(t) \ r^T(t) \ e_a^T(t)]^T$  are proved to be semi-globally uniformly ultimately bounded. Hereafter, a further analysis was presented (Alibeji & Sharma, 2017) to illustrate the delay-robustness of the same controller.

However, the methods mentioned above are based on the hypothesis that  $M(q(t))$  is uncertain and  $V_m(q(t), \dot{q}(t)), G(q(t)), F(\dot{q}(t))$  are unknown, thus they cannot guarantee the global stability/boundedness results of the trajectory tracking system. Subsequently, it was revealed in (Bagheri, Krstić, & Naseradinmousavi, 2018; Bagheri, Naseradinmousavi, & Krstić, 2019b; Bagheri et al., 2019b; Osuna-Ibarra, Caballero-Barragan, & Loukianov, 2020) that (58) could be globally stabilisable if the forces/torques  $V_m(q(t), \dot{q}(t)), G(q(t)), F(\dot{q}(t))$  were measurable. By defining another auxiliary state  $E(t) = [e_1^T(t) \ e_{2a}^T(t)]^T$ , the original Euler-Lagrange system (58) could be rearranged in the following nonlinear form:

$$\dot{E}(t) = f(E(t), U(t-h), d(t)). \quad (62)$$

Thus, it is possible to derive the global input-to-state stability of the tracking error system (62) by combining the feedback linearisation technique (Slotine & Li, 1991, Chapter 6) and the following approximated state prediction:

$$P(t) = E(t) + \int_{t-h}^t f(P(s), U(s)) ds. \quad (63)$$

The two aforementioned approaches were implemented on several practical systems. In (Sharma, Gregory, & Dixon, 2011; Qiu, Alibeji, & Sharma, 2016), the robust predictive controllers were applied to neuromuscular rehabilitation systems, and a similar delay compensation technique was further designed for musculoskeletal wearable systems (Alibeji, Dicianno, & Sharma, 2017; Alibeji, Kirsch, & Sharma, 2017; Sheng, Sun, Molazadeh, & Sharma, 2021). The second method (62)–(63) handled the accurate grasp-place control of a 7-DoF Baxter manipulator (Bagheri et al., 2018, 2019b, 2019b).

In addition, the predictor-based controller was also applied successfully in space robot systems thanks to the capacity of compensating for extremely long actuation and communication delays. The truncated predictor-based controller was applied in (Zhou & Li, 2015) to accomplish the elliptical spacecraft rendezvous task. In (Chen, Huang, & Liu, 2019), a neural-networked-based predictor was adopted to deal with the random delay of a bilateral teleoperation space robot system. More recently, the predictor-based vibration control of a flexible satellite was considered in (Ma, He, Chen, & He, 2021); and in (Peng, Zhou, Yu, Guo, & Geng, 2021) the predictive control scheme was extended to the  $SE(3)$  space that is widely utilised by the robotic community.

Besides, the proposed control techniques were also applied in other applications such as networked unicycle-type mobile robots (Alvarez-Aguirre, Van De Wouw, Oguchi, & Nijmeijer, 2014), discrete-time robotic systems in the port-controlled Hamiltonian form (Franco, 2018) and autonomous underwater vehicles with input delays (Mukherjee, Kar, & Bhatt, 2015).



## 6. New trends of predictor-based control techniques for further research

Previous sections present a review of the theoretical developments and practical applications of predictor-based controllers. Some potential research directions that are worthy of further considerations will be outlined in this section.

### 6.1. Predictor-based control under communication constraints and cyber attacks

The booming developments in computer science and telecommunications open a new dimension for TDS: network-based systems. On the one hand, the communication network unquestionably improves the adaptability to intricate tasks; on the other hand, the communication protocols are risky to suffer from communication issues, *i.e.* packet loss, quantization and cyber attack. In order to attain an effective delay compensation for such systems, one must verify the resilience of predictor-based controllers against these constraints. Recall that several references presented in the previous sections have concerned one of the network-induced constraints: non-differentiable delay jumps (Bresch-Pietri et al., 2018), packet dropouts (Yang et al., 2017), packet disordering (García et al., 2006; Cloosterman et al., 2009; García et al., 2010; González et al., 2012, 2013; González, 2013; Deng, Léchappé, Zhang, et al., 2021), quantizations (Léchappé et al., 2019).

**Future research topics.** Nevertheless, the above predictor-based controllers did not consider the mixed network imperfections, and the cyber attack was not taken into account. In the future, it would be preferable to explore more robust predictor-based control techniques for CPSs due to the significant application prospects. Furthermore, the deception attack detection methods (Zhang et al., 2022) could be integrated into the predictor-based controller design for detecting, estimating, and counteracting cyber attacks.

### 6.2. Dynamic event-triggered predictor-based controllers

Event-triggered mechanism is an efficient solution to achieve good control performance by using limited system resources, *i.e.* computational cost and network bandwidth. Such a protocol brings in the capacity to determine the most indispensable execution instants of sensing/controlling: the sensor measurements/control law updates will only be permitted when some predetermined switching conditions are satisfied. For linear systems, the event-triggered predictor-based control has been conducted in (Selivanov & Fridman, 2016b, 2016a; Zhu & Fridman, 2021) through the continuous-time approach and (Yang et al., 2017; Yang & Zheng, 2019; Léchappé et al., 2019; Xie et al., 2020; González, 2021) by means of the discrete-time method. More recently, the authors of (Nozari, Tallapragada, & Cortés, 2020; Sun, Yang, & Zeng, 2022) developed event-triggered predictor-based controllers for nonlinear TDSs with time-varying delays or model uncertainties.

**Future research topics.** However, the efficiencies of the above event-triggered predictor-based controllers still have development space since they only adopted static event-triggered mechanism. Recently, the dynamic event-triggered methodology (Ge, Han, Zhang, & Ding, 2021) draws the attention of the control community thanks to its adaptability and flexibility. This method could autonomously tune the event-triggered conditions to match the actual system situations, *e.g.* system states, perturbation levels, network bandwidth. Hence, the dynamic event-triggered predictor-based control will be a valuable research topic for future work, in which the delay size, delay variation, and network bandwidth could be probably employed to well-adjust the event-triggered conditions.

### 6.3. Finite-time and fixed-time predictor-based controllers

The finite-time stabilisation of TDS (Moulay, Dambrine, Yeganefer, & Perruquetti, 2008) increasingly attracts the interests of the researchers, aiming to drive the system states to zero in a prescribed finite-time. In addition, if the convergence time is independent of the initial conditions  $X_0, U_0 \in \mathbf{C}^1([-h, 0])$ , then the control problem is upgraded to the fixed-time stabilisation (Polyakov, 2011).

Homogeneous approach (Efimov, Polyakov, Perruquetti, & Richard, 2016) and periodic delay feedback (Insperger, 2006) are effective ways to achieve finite-time convergence, and they are combined with the predictor-based control techniques for the stabilisation of TDSs with long time delays. In (Moulay et

al., 2008), the homogeneous feedback control law was built on an Artstein’s model reduction (Artstein, 1982) for realising finite-time control of an integral system. A periodic predictor-based control was involved in (Karafyllis, 2005) to stabilise a class of nonlinear triangular systems with time-delays. The fixed-time stabilisation problem of LTI TDSs with constant input delays was solved in (Zhou, Michiels, & Chen, 2021; Espitia & Perruquetti, 2021). In (Espitia & Perruquetti, 2021), a PDE-based predictor-based controller was designed for LTI systems in the canonical controllability form: the trajectories of the system are steered onto a fixed-time stable target system by virtue of a new Volterra backstepping transformation with time-varying kernel function and that is an upgraded version of (28). In (Zhou et al., 2021), an act-and-wait periodic predictor-based control, state-feedback and output-feedback, of general LTI TDSs was proposed to guarantee the fixed-time stability; the control law is smooth and robust to slight model uncertainties. Moreover, the main advantage of (Zhou et al., 2021) over (Espitia & Perruquetti, 2021) is the avoidance of singularity, *i.e.* the control law of (Zhou et al., 2021) will not tend towards infinity when the prescribed convergence time approaches.

**Future research topics.** In the future, the robust finite-time/fixed-time predictor-based controllers could be further investigated: the robustness of the control laws was not discussed in (Moulay et al., 2008; Karafyllis, 2005; Espitia & Perruquetti, 2021), and the fixed-time stability of (Zhou et al., 2021) is readily degraded to exponential stability under model uncertainties. Therefore, preserving the finite-time/fixed-time stability of TDSs despite model uncertainties and external disturbances will be a valuable topic for future researches.

#### 6.4. New robust prediction schemes

Predictor-based control can effectively render the closed-loop system delay-free by perfectly predicting the future state. However, the accurate state prediction is not accessible when the TDS is perturbed by the external disturbance, which will degrade the control performances. For instance, the exact state prediction of the following perturbed LTI TDS:

$$\dot{X}(t) = AX(t) + BU(t-h) + d(t), \quad (64)$$

reads as:

$$X(t+h) = e^{Ah}X(t) + \int_{t-h}^t e^{A(t-s)} [BU(s) + d(s)] ds = P(t) + \int_{t-h}^t e^{A(t-s)} d(s) ds, \quad (65)$$

where  $P(t)$  denotes the right-hand side of (3) computed by known variables, *i.e.* the approximated prediction. In view of the above example, it would be meaningful to explore novel robust prediction schemes that lessen the negative influences of  $\int_{t-h}^t e^{A(t-s)} d(s) ds$ .

During the last few years, several works committed to designing new robust prediction schemes by estimating/counteracting the unknown disturbance  $d(t)$ . In (Teng & Yamashita, 2011), a modified prediction framework was carried out to approximate the PDE-based implicit term  $p(x, \cdot)$  defined in (31) by an ODE-based explicit term, but this prediction scheme is also valuable for ameliorating the robustness.

The control scheme of (Teng & Yamashita, 2011) is depicted in Figure 8, in which an artificial

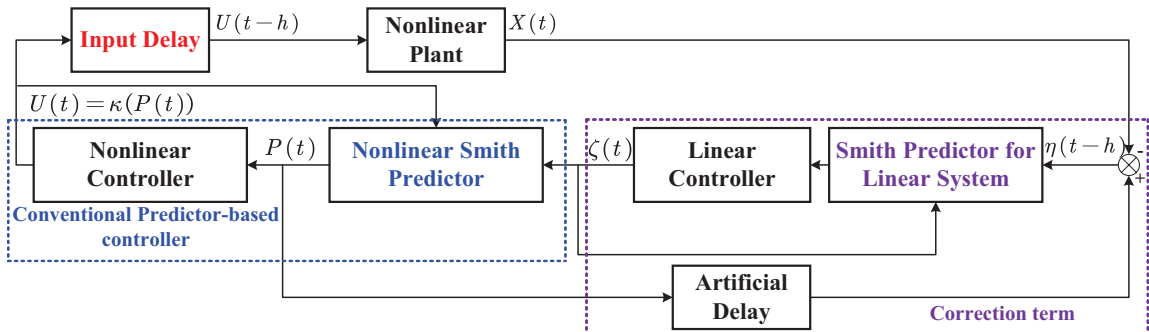

Figure 8.: Modified prediction scheme for nonlinear TDSs with constant input delays.

delay is imposed on the output  $P(t)$  of the conventional predictor. Thus, the error signal  $\eta(t-h) \triangleq P(t-h) - X(t)$  could evaluate the deviation of the approximated prediction  $P(t)$  from the exact one. Finally,  $\eta(t-h)$  is utilised to compute an injection term  $\zeta(t)$  that improves the robustness of the state prediction. In (Léchappé, Moulay, Plestan, Glumineau, & Chriette, 2015), the closed-loop performances under the prediction scheme:

$$X_p(t) = P(t) + [X(t) - P(t-h)] \quad (66)$$

were carefully analysed and verified; the main characteristic of (66) is twofold:

- If  $d(t)$  in (64) is constant, then  $X_p(t)$  is a perfect prediction of  $X(t+h)$ .
- If  $d(t)$  in (64) is time-varying, then  $X_p(t)$  will still be better than the conventional one if a delay-dependent condition is fulfilled.

The robust prediction scheme (66) was further applied in (Loukianov, Caballero-Barragán, Osuna-Ibarra, Espinosa-Guerra, & Castillo-Toledo, 2017; Caballero-Barragán, Osuna-Ibarra, Loukianov, & Plestan, 2018) to design a predictive sliding mode controller for uncertain LTI TDSs.

Inspired by the work of (Léchappé et al., 2015), several modifications are made on the robust prediction scheme (66). In (Santos, 2016), a stable filter  $F(s)$  was added onto (66):

$$X_p(t) = P(t) + \mathcal{L}^{-1}\{F(s)\mathcal{L}[X(t) - P(t-h)]\}, \quad (67)$$

for contributing to a better disturbance attenuation ability. Hereafter, the following DOB-based prediction scheme has intensively attracted the attention of the researchers:

$$X_p(t) = e^{Ah}X(t) + \int_{t-h}^t e^{A(t-s)} [BU(s) + \hat{d}(s)] ds, \quad (68)$$

where  $\hat{d}(t)$  represents the online estimation of the unknown disturbance  $d(t)$  of (64) via ESO-based approaches (Sanz, Garcia, & Albertos, 2016; Sanz, Garcia, Albertos, & Zhong, 2017) and HOSM-based techniques (Shi, Liu, Lu, & Chu, 2018; Shi, Xu, Li, Chu, & Zhang, 2018; Shi, Xu, Gu, & Zhang, 2021). Besides, several innovative prediction schemes were exploited in recent years. The authors of (Wang & Wu, 2019) proposed an “iterative” version of (66) with the expression:

$$\bar{X}_p(t) = X_p(t) + [X(t) - X_p(t-h)], \quad (69)$$

where  $X_p(t)$  denotes the output of (66). Some analysis and simulation results demonstrate that the iterative prediction scheme (69) yields better robustness than (Léchappé et al., 2015; Sanz et al., 2016). In (Nguyen & Dankowicz, 2019), the  $\mathcal{L}_1$  controller was involved in designing a robust state prediction, and a discretisation-based high-order ESO was utilised in (Castillo & García, 2021) for enhancing the prediction performances. Finally, the interval-prediction technique (Polyakov et al., 2013) and the observation-based predictor (50) were combined in (González Sorribes & García Gil, 2021) to deal with the robust observation-predictor-based stabilisation of linear TDSs with time-varying input delays.

**Future research topics.** Even though the robust prediction scheme has been aware of and considered by various researchers, this technique could be more deeply studied according to the following aspects:

- Almost all of the aforementioned methods were designed for TDSs with constant input delays, except (González Sorribes & García Gil, 2021), it would be interesting to examine if any further modification is required when extending the robust prediction schemes to TDSs subject to time-varying delays.
- The existing approaches were devoted to analysing the sensitivity to the external disturbances or model uncertainties, but the delay-robustness of them is worthy of consideration as well. Furthermore, the combination of the new prediction schemes and the delay estimation algorithms proposed in Subsections 2.4 and 3.3 could be investigated for future research activities.

### 6.5. Predictor-based control of underactuated robotic systems

Underactuated robotic systems, *e.g.* underwater robot (Mukherjee et al., 2015), surface vessel (Wang & Han, 2017), motorcycle (Yi, Zhang, & Song, 2009), constitute a noteworthy branch of robotics since such configurations regularly have the benefits of low cost and less energy consumption, but the controller design of them is more challenging. Autonomous control of retarded underactuated robots could be potentially applied to long-distance unmanned tasks, *e.g.* ocean exploration by underwater robots, off-road reconnaissance of motorcycles or teleoperation of underactuated space manipulators.

**Future research topics.** Among the existing methods exhibited in Subsection 5.3, the predictor-based control problem of underactuated systems was only tackled in (Zhou & Li, 2015; Franco, 2018). However, these approaches were limited since the control algorithm (Zhou & Li, 2015) was based on the local linearisation and the controller of (Franco, 2018) was only designed for discrete-time systems. Moreover, the predictor-based stabilisation of delayed underactuated Euler-Lagrange systems is not perfectly resolved, since all theoretical results (Sharma, Bhasin, et al., 2011; Alibeji & Sharma, 2017; Bagheri et al., 2018, 2019b; Bagheri, Naseradinmousavi, & Krstić, 2019a; Osuna-Ibarra et al., 2020) were designed for full actuated mechanical systems. Therefore, exploiting a systematic predictor-based control technique for underactuated robotic systems will be essential for future research.

## 7. Conclusion

This paper presents a review of the methodologies and applications of predictor-based control techniques for various TDSs with long time delays. Based on different categories of design and stability analysis methods, the up-to-date approaches are systematically exhibited and explicated. Thereafter, this paper reveals the interconnections and comparisons between the existing predictive control schemes. After introducing the theoretical advances in predictor-based control methods, this paper discusses the numerical implementations of the algorithms and the applications to several characteristic TDSs. Finally, several challenging questions for future researches are drawn at the end of the paper.

## Data Availability Statement

The authors confirm that data and materials that support the results or analyses presented in this paper are freely available upon request.

## References

- Ahmed-Ali, T., Cherrier, E., & Lammabhi-Lagarrigue, F. (2012). Cascade high gain predictors for a class of nonlinear systems. *IEEE Transactions on Automatic Control*, *57*(1), 221–226.
- Alcántara, S., Ibeas, A., Herrera, J. A., Vilanova, R., & Pedret, C. (2009). Multi-model smith predictor based control of multivariable systems with uncertain bounded external delays. *IEEE Latin America Transactions*, *7*(1), 42–53.
- Alibeji, N., Dicianno, B. E., & Sharma, N. (2017). Bilateral control of functional electrical stimulation and robotics-based telerehabilitation. *International Journal of Intelligent Robotics and Applications*, *1*(1), 6–18.
- Alibeji, N., Kirsch, N., & Sharma, N. (2017). An adaptive low-dimensional control to compensate for actuator redundancy and FES-induced muscle fatigue in a hybrid neuroprosthesis. *Control Engineering Practice*, *59*, 204–219.
- Alibeji, N., & Sharma, N. (2017). A PID-type robust input delay compensation method for uncertain Euler-Lagrange systems. *IEEE Transactions on Control Systems Technology*, *25*(6), 2235–2242.
- Alvarez-Aguirre, A., Van De Wouw, N., Oguchi, T., & Nijmeijer, H. (2014). Predictor-based remote tracking control of a mobile robot. *IEEE Transactions on Control Systems Technology*, *22*(6), 2087–2102.
- Angeli, D., & Sontag, E. D. (1999). Forward completeness, unboundedness observability, and their Lyapunov characterizations. *Systems & Control Letters*, *38*(4–5).
- Artstein, Z. (1982). Linear systems with delayed controls: A reduction. *IEEE Transactions on Automatic control*, *27*(4), 869–879.
- Bagheri, M., Krstić, M., & Naseradinmousavi, P. (2018). Analytical and experimental predictor-based time delay control of baxter robot. In *Proceedings of the ASME 2018 Dynamic Systems and Control Conference* (Vol. 51890). Atlanta, Georgia, USA.
- Bagheri, M., Naseradinmousavi, P., & Krstić, M. (2019a). Feedback linearization based predictor for time delay control of a high-DOF robot manipulator. *Automatica*, *108*(108485).
- Bagheri, M., Naseradinmousavi, P., & Krstić, M. (2019b). Time delay control of a high-DOF robot manipulator through feedback linearization based predictor. In *Proceedings of the ASME 2019 Dynamic Systems and Control Conference* (Vol. 59162).
- Bekiaris-Liberis, N., Jankovic, M., & Krstic, M. (2012). Compensation of state-dependent state delay for nonlinear systems. *Systems & Control Letters*, *61*(8), 849–856.
- Bekiaris-Liberis, N., & Krstic, M. (2011). Lyapunov stability of linear predictor feedback for distributed input delays. *IEEE Transactions on Automatic Control*, *56*(3), 655–660.
- Bekiaris-Liberis, N., & Krstic, M. (2012). Compensation of time-varying input and state delays for nonlinear systems. *Journal of Dynamic Systems, Measurement, and Control*, *134*(011009).
- Bekiaris-Liberis, N., & Krstic, M. (2013a). Compensation of state-dependent input delay for nonlinear systems. *IEEE Transactions on Automatic Control*, *58*(12), 275–289.
- Bekiaris-Liberis, N., & Krstic, M. (2013b). *Nonlinear control under nonconstant delays*. Philadelphia, PA, USA: SIAM.
- Bekiaris-Liberis, N., & Krstic, M. (2013c). Robustness of nonlinear predictor feedback laws to time-and state-dependent delay perturbations. *Automatica*, *49*(6), 1576–1590.
- Bekiaris-Liberis, N., & Krstic, M. (2013d). Robustness to time-and state-dependent delay perturbations in networked nonlinear control systems. In *Proceedings of the 2013 American Control Conference (ACC)* (pp. 2074–2079). Washington, DC, USA.
- Bekiaris-Liberis, N., & Krstic, M. (2017). Predictor-feedback stabilization of multi-input nonlinear systems. *IEEE Transactions on Automatic Control*, *52*(2), 516–531.
- Besançon, G., Georges, D., & Benayache, Z. (2007). Asymptotic state prediction for continuous-time systems with delayed input and application to control. In *Proceedings of the 2007 European Control Conference (ECC)* (pp. 1786–1791). Kos, Greece: IEEE.

- Bresch-Pietri, D. (2012). *Robust control of variable time-delay systems. Theoretical contributions and applications to engine control.* (Doctoral dissertation, MINES ParisTech). Retrieved from <https://tel.archives-ouvertes.fr/pastel-00803271>
- Bresch-Pietri, D., Chauvin, J., & Petit, N. (2010). Adaptive backstepping controller for uncertain systems with unknown input time-delay. Application to SI engines. In *Proceedings of the 49th IEEE Conference on Decision and Control (CDC)* (pp. 3680–3687). Atlanta, GA, USA.
- Bresch-Pietri, D., Chauvin, J., & Petit, N. (2011a). Adaptive backstepping for uncertain systems with time-delay on-line update laws. In *Proceedings of the 2011 American Control Conference* (pp. 4890–4897). San Francisco, CA, USA.
- Bresch-Pietri, D., Chauvin, J., & Petit, N. (2011b). Output feedback control of time delay systems with adaptation of delay estimate. In *Proceedings of the 18th IFAC World Congress* (pp. 7606–7612). Milano, Italy: Elsevier.
- Bresch-Pietri, D., Chauvin, J., & Petit, N. (2012). Adaptive control scheme for uncertain time-delay systems. *Automatica*, *48*(8), 1536–1552.
- Bresch-Pietri, D., & Krstic, M. (2009a). Adaptive tracking controller for systems with unknown long delay and unknown parameters in the plant. In *Proceedings of the 2009 American Control Conference (ACC)* (pp. 2575–2580). St. Louis, MO, USA.
- Bresch-Pietri, D., & Krstic, M. (2009b). Adaptive trajectory tracking despite unknown input delay and plant parameters. *Automatica*, *45*(9), 2074–2081.
- Bresch-Pietri, D., & Krstic, M. (2010). Delay-adaptive predictor feedback for systems with unknown long actuator delay. *IEEE Transactions on Automatic Control*, *55*(9), 2106–2112.
- Bresch-Pietri, D., Mazenc, F., & Petit, N. (2018). Robust compensation of a chattering time-varying input delay with jumps. *Automatica*, *92*, 225–234.
- Bresch-Pietri, D., & Petit, N. (2014). Prediction-based control for linear systems with input-and state-delay-robustness to delay mismatch. In *Proceedings of the 19th IFAC World Congress* (pp. 11410–11418). Cape Town, South Africa: Elsevier.
- Bresch-Pietri, D., Petit, N., & Krstic, M. (2015). Prediction-based control for nonlinear state-and input-delay systems with the aim of delay-robustness analysis. In *Proceedings of the 54th IEEE Conference on Decision and Control (CDC)* (pp. 6403–6409). Osaka, Japan.
- Caballero-Barragán, H., Osuna-Ibarra, L. P., Loukianov, A. G., & Plestan, F. (2018). Sliding mode predictive control of linear uncertain systems with delays. *Automatica*, *94*, 409–415.
- Cacace, F., Conte, F., Germani, A., & Pepe, P. (2016). Stabilization of strict-feedback nonlinear systems with input delay using closed-loop predictors. *International Journal of Robust and Nonlinear Control*, *26*(16), 3524–3540.
- Cacace, F., Germani, A., & Manes, C. (2014). Predictor-based control of linear systems with large and variable measurement delays. *International Journal of Control*, *87*(4), 704–714.
- Cai, X., Bekiaris-Liberis, N., & Krstic, M. (2019). Input-to-state stability and inverse optimality of predictor feedback for multi-input linear systems. *Automatica*, *103*, 549–557.
- Cai, X., Liao, L., Liu, Y., & Lin, C. (2017). Predictor-based stabilisation for discrete nonlinear systems with state-dependent input delays. *International Journal of Systems Science*, *48*(4), 769–777.
- Castillo, A., & García, P. (2021). Predicting the future state of disturbed LTI systems: A solution based on high-order observers. *Automatica*, *124*(109365).
- Chakraborty, I., Mehta, S. S., Doucette, E., & Dixon, W. E. (2017). Control of an input delayed uncertain nonlinear system with adaptive delay estimation. In *Proceedings of the 2017 American Control Conference (ACC)* (pp. 1779–1784). Seattle, WA, USA.
- Chen, H., Huang, P., & Liu, Z. (2019). Mode switching-based symmetric predictive control mechanism for networked teleoperation space robot system. *IEEE/ASME Transactions on Mechatronics*, *24*(6), 2706–2717.
- Chen, L., Edwards, C., Alwi, H., & Sato, M. (2022). Simultaneous fault and input time delay estimation for an actuator system: theory and flight data validation. *IEEE Control Systems Letters*, *6*, 1172–1177.
- Choi, J.-Y., & Krstic, M. (2016). Compensation of time-varying input delay for discrete-time nonlinear systems. *International Journal of Robust and Nonlinear Control*, *26*(8), 1755–1776.
- Chu, H., Yue, D., Dou, C., Xie, X., & Chu, L. (2021). Consensus of multiagent systems with time-varying input delay via truncated predictor feedback. *IEEE Transactions on Systems, Man, and Cybernetics: Systems*, *51*(10), 6062–6073.

- Cloosterman, M. B., Van de Wouw, N., Heemels, W., & Nijmeijer, H. (2009). Stability of networked control systems with uncertain time-varying delays. *IEEE Transactions on Automatic Control*, *54*(7), 1575–1580.
- Deng, W., Yao, J., & Ma, D. (2018). Time-varying input delay compensation for nonlinear systems with additive disturbance: An output feedback approach. *International Journal of Robust and Nonlinear Control*, *28*(1), 31–52.
- Deng, Y., Léchappé, V., Molay, E., & Plestan, F. (2021). Predictor-based control of LTI remote systems with estimated time-varying delays. *IEEE Control Systems Letters*, *5*(1), 289–294.
- Deng, Y., Léchappé, V., Moulay, E., & Plestan, F. (2019). Prediction-based control with delay estimation of LTI systems with input-output delays. In *Proceedings of the 2019 American Control Conference (ACC)* (pp. 3702–3707). Philadelphia, PA, USA.
- Deng, Y., Léchappé, V., Moulay, E., & Plestan, F. (2021). State feedback control and delay estimation for LTI system with unknown input-delay. *International Journal of Control*, *94*(9), 2369–2378.
- Deng, Y., Léchappé, V., Rouquet, S., Moulay, E., & Plestan, F. (2020a). A practical online time-varying delay estimation of remote control system based on adaptive super-twisting algorithm. In *Proceedings of the 2020 IEEE Conference on Control Technology and Applications (CCTA)* (pp. 885–891). Montréal, Canada.
- Deng, Y., Léchappé, V., Rouquet, S., Moulay, E., & Plestan, F. (2020b). Super-twisting algorithm-based time-varying delay estimation with external signal. *IEEE Transactions on Industrial Electronics*, *67*(12), 10663–10671.
- Deng, Y., Léchappé, V., Zhang, C., Moulay, E., Du, D., Plestan, F., & Han, Q.-L. (2021). Designing discrete predictor-based controllers for networked control systems with time-varying delays: Application to a visual servo inverted pendulum system. *IEEE/CAA Journal of Automatica Sinica*(Early Access). (doi: 10.1109/JAS.2021.1004249)
- Dev, A., Anand, S., & Sarkar, M. K. (2019). Prediction-based sliding mode load frequency control with unknown I/O time delays using delay and disturbance estimation. In *Proceedings of the 2019 Sixth Indian Control Conference (ICC)* (pp. 443–448). Hyderabad, India: IEEE.
- Dev, A., Léchappé, V., & Sarkar, M. K. (2021). Prediction-based super twisting sliding mode load frequency control for multi-area interconnected power systems with state and input time delays using disturbance observer. *International Journal of Control*, *94*(7), 1751–1764.
- Ding, Z., & Lin, Z. (2014). Truncated state prediction for control of Lipschitz nonlinear systems with input delay. In *Proceedings of the 53rd IEEE Conference on Decision and Control (CDC)* (pp. 1966–1971). Los Angeles, CA, USA: IEEE.
- Dinh, H. T., Fischer, N., Kamalapurkar, R., & Dixon, W. E. (2013). Output feedback control for uncertain nonlinear systems with slowly varying input delay. In *Proceedings of the 2013 American Control Conference (ACC)* (pp. 1745–1750).
- Diop, S., Kolmanovsky, I., Moraal, P., & Van Nieuwstadt, M. (2001). Preserving stability/ performance when facing an unknown time-delay. *Control Engineering Practice*, *9*(12), 1319–1325.
- Drakunov, S. V., Perruquetti, W., Richard, J.-P., & Belkoura, L. (2006). Delay identification in time-delay systems using variable structure observers. *Annual Reviews in Control*, *30*(2), 143–158.
- Du, D., Zhang, C., Song, Y., Zhou, H., Li, X., Fei, M., & Li, W. (2020). Real-time  $h_\infty$  control of networked inverted pendulum visual servo systems. *IEEE transactions on Cybernetics*, *50*(12), 5113–5126.
- Efimov, D., Polyakov, A., Perruquetti, W., & Richard, J.-P. (2016). Weighted homogeneity for time-delay systems: Finite-time and independent of delay stability. *IEEE Transactions on Automatic Control*, *61*(1), 210–215.
- Engelborghs, K., Dambrine, M., & Roose, D. (2001). Limitations of a class of stabilization methods for delay systems. *IEEE Transactions on Automatic Control*, *46*(2), 336–339.
- Espitia, N., & Perruquetti, W. (2021). Predictor-feedback prescribed-time stabilization of LTI systems with input delay. *IEEE Transactions on Automatic Control*(Early Access). (doi: 10.1109/TAC.2021.3093527)
- Francis, B. A., & Georgiou, T. T. (1988). Stability theory for linear time-invariant plants with periodic digital controllers. *IEEE transactions on Automatic Control*, *33*(9), 820–832.
- Franco, E. (2018). Discrete-time IDA-PBC for underactuated mechanical systems with input-delay and matched disturbances. In *Proceedings of the 26th Mediterranean Conference on Control and Automation (MED)* (pp. 747–752). Zadar, Croatia.



- Fridman, E. (2014). *Introduction to Time-delay systems: Analysis and Control*. New York, USA: Springer.
- Furukawa, T., & Shimemura, E. (1983). Predictive control for systems with time delay. *International Journal of Control*, *37*(2), 399–412.
- García, P., Castillo, P., Lozano, R., & Albertos, P. (2006). Robustness with respect to delay uncertainties of a predictor-observer based discrete-time controller. In *Proceedings of the 45th IEEE Conference on Decision and Control* (pp. 199–204). San Diego, California, USA: IEEE.
- García, P., González, A., Castillo, P., Lozano, R., & Albertos, P. (2010). Robustness of a discrete-time predictor-based controller for time-varying measurement delay. In *Proceedings of the 9th IFAC Workshop on Time Delay Systems* (pp. 367–372). Prague, Czech Republic: Elsevier.
- Gaudette, D. L., & Miller, D. E. (2014). Stabilizing a SISO LTI plant with gain and delay margins as large as desired. *IEEE Transactions on Automatic Control*, *59*(9), 2324–2339.
- Gaudette, D. L., & Miller, D. E. (2016). Adaptive stabilization of a class of time-varying systems with an uncertain delay. *Mathematics of Control, Signals, and Systems*, *28*(3), 1–39.
- Ge, X., Han, Q.-L., Zhang, X.-M., & Ding, D. (2021). Dynamic event-triggered control and estimation: A survey. *International Journal of Automation and Computing*, *18*(6), 857–886.
- González, A. (2012). Robustness of a discrete-time predictor-based controller for time-varying measurement delay. *Control Engineering Practice*, *20*(2), 102–110.
- González, A. (2013). Robust stabilization of linear discrete-time systems with time-varying input delay. *Automatica*, *49*(9), 2919–2922.
- González, A. (2021). A weighted distributed predictor-feedback control synthesis for interconnected time delay systems. *Information Sciences*, *543*, 367–381.
- González, A., & García, P. (2021). Output-feedback anti-disturbance predictor-based control for discrete-time systems with time-varying input delays. *Automatica*, *129*, 109627.
- González, A., Sala, A., & Albertos, P. (2012). Predictor-based stabilization of discrete time-varying input-delay systems. *Automatica*, *48*(2), 454–457.
- González, A., Sala, A., García, P., & Albertos, P. (2013). Robustness analysis of discrete predictor-based controllers for input-delay systems. *International Journal of Systems Science*, *44*(2), 232–239.
- González Sorribes, A., & García Gil, P. (2021). A novel observer-predictor control for uncertain systems with unknown time-varying input and output delays. *International Journal of Control*, *94*(6), 1630–1640.
- Gu, K., Chen, J., & Kharitonov, V. L. (2003). *Stability of Time-Delay Systems*. Boston, MA, USA: Birkhäuser.
- Hale, J. K., & Lunel, S. M. V. (2013). *Introduction to functional differential equations* (Vol. 99). New York, USA: Springer Science & Business Media.
- Hao, S., Liu, T., & Zhou, B. (2019). Output feedback anti-disturbance control of input-delayed systems with time-varying uncertainties. *Automatica*, *104*, 8–16.
- Herrera, J., & Ibeas, A. (2012). On-line delay estimation for stable, unstable and integrating systems under step response. *ISA transactions*, *51*(3), 351–361.
- Hu, S., & Zhu, Q. (2003). Stochastic optimal control and analysis of stability of networked control systems with long delay. *Automatica*, *39*(11), 1877–1884.
- Huang, C., & Yu, C. (2017). Global adaptive controller for linear systems with unknown input delay. *IEEE Transactions on Automatic Control*, *62*(12), 6589–6594.
- Huang, R., & Ding, Z. (2020). Robustness to delay mismatch in consensus control under undirected graphs. In *Proceedings of the 21st IFAC World Congress* (pp. 7671–7676). Berlin, Germany: Elsevier.
- Huang, R., & Ding, Z. (2021a). Adaptive delay compensation for consensus control under switching topologies by observer-predictor. *Automatica*, *132*(109811).
- Huang, R., & Ding, Z. (2021b). On compensating actuator delays in consensus control under undirected graphs. *IEEE Transactions on Automatic Control*, *66*(10), 4769–4776.
- Huang, R., Ding, Z., & Cao, Z. (2020). Distributed output feedback consensus control of networked homogeneous systems with large unknown actuator and sensor delays. *Automatica*, *122*(109249).
- Inspurger, T. (2006). Act-and-wait concept for continuous-time control systems with feedback delay. *IEEE Transactions on Control Systems Technology*, *14*(5), 974–977.

- Jiang, W., Chen, Y., & Charalambous, T. (2020). Consensus of general linear multi-agent systems with heterogeneous input and communication delays. *IEEE Control Systems Letters*, 5(3), 851–856.
- Jiang, W., Peng, Z., Rahmani, A., Hu, W., & Wen, G. (2018). Distributed consensus of linear mass with an unknown leader via a predictive extended state observer considering input delay and disturbances. *Neurocomputing*, 315, 465–475.
- Jo, H.-W., Choi, H.-L., & Lim, J.-T. (2014). Observer based output feedback regulation of a class of feedforward nonlinear systems with uncertain input and state delays using adaptive gain. *Systems & Control Letters*, 71, 44–53.
- Juárez, L., Mondié, S., & Kharitonov, V. L. (2020). Dynamic predictor for systems with state and input delay: A time-domain robust stability analysis. *International Journal of Robust and Nonlinear Control*, 30(6), 2204–2218.
- Karafyllis, I. (2005). Finite-time global stabilization by means of time-varying distributed delay feedback. In *Proceedings of the 44th IEEE Conference on Decision and Control* (pp. 5776–5781). Seville, Spain: IEEE.
- Karafyllis, I., & Krstic, M. (2013a). Delay-robustness of linear predictor feedback without restriction on delay rate. *Automatica*, 49(6), 1761–1767.
- Karafyllis, I., & Krstic, M. (2013b). Stabilization of nonlinear delay systems using approximate predictors and high-gain observers. *Automatica*, 49(12), 3623–3631.
- Karafyllis, I., & Krstic, M. (2016). Approximate and sampled-data predictors for control of nonlinear delay systems. *Annual Reviews in Control*, 41, 2–12.
- Karafyllis, I., & Krstic, M. (2017). *Predictor feedback for delay systems: Implementations and approximations*. Cham, Switzerland: Springer.
- Karafyllis, I., Malisoff, M., Mazenc, F., & Pepe, P. (2016). *Recent results on nonlinear delay control systems*. Cham, Switzerland: Springer.
- Katz, R., & Fridman, E. (2021). Sub-predictors and classical predictors for finite-dimensional observer-based control of parabolic pdes. *IEEE Control Systems Letters*, 6, 626–631.
- Koo, M.-S., & Choi, H.-L. (2016a). Non-predictor controller for feedforward and non-feedforward nonlinear systems with an unknown time-varying delay in the input. *Automatica*, 65, 27–35.
- Koo, M.-S., & Choi, H.-L. (2016b). Non-predictor control of a class of feedforward nonlinear systems with unknown time-varying delays. *International Journal of Control*, 89(8), 1675–1683.
- Koo, M.-S., & Choi, H.-L. (2017). Output feedback regulation of upper triangular nonlinear systems with uncertain time-varying delays in states and input. *International Journal of Robust and Nonlinear Control*, 27(18), 5129–5144.
- Koo, M.-S., & Choi, H.-L. (2018). Adaptive non-predictor control of lower triangular uncertain nonlinear systems with an unknown time-varying delay in the input. *International Journal of Systems Science*, 49(1), 124–131.
- Koo, M.-S., & Choi, H.-L. (2021). Global regulation of high-order feedforward and non-feedforward systems with unknown time-varying delays in states and input. *International Journal of Control*, 94(6), 1611–1621.
- Krstic, M. (2008). Lyapunov tools for predictor feedbacks for delay systems: Inverse optimality and robustness to delay mismatch. *Automatica*, 44(11), 2930–2935.
- Krstic, M. (2009). *Delay Compensation for Nonlinear, Adaptive, and PDE Systems*. New York, NY, USA: Birkhäuser Boston.
- Krstic, M. (2010a). Input delay compensation for forward complete and strict-feedforward nonlinear systems. *IEEE Transactions on Automatic Control*, 55(2), 287–303.
- Krstic, M. (2010b). Lyapunov stability of linear predictor feedback for time-varying input delay. *IEEE Transactions on Automatic Control*, 55(2), 554–559.
- Krstic, M., & Bekiaris-Liberis, N. (2012). Control of nonlinear delay systems: A tutorial. In *Proceedings of the 51st IEEE Conference on Decision and Control (CDC)* (pp. 5200–5214). Maui, HI, USA: IEEE.
- Krstic, M., & Bresch-Pietri, D. (2009). Delay-adaptive full-state predictor feedback for systems with unknown long actuator delay. In *Proceedings of the 2009 American Control Conference (ACC)* (pp. 4500–4505). St. Louis, MO, USA: IEEE.
- Krstić, M., Kanellakopoulos, I., & Kokotović, P. (1995). *Nonlinear and Adaptive Control Design*. New York, NY, USA: John Wiley.

- Lai, C.-L., & Hsu, P.-L. (2010). Design the remote control system with the time-delay estimator and the adaptive smith predictor. *IEEE Transactions on Industrial Informatics*, 6(1), 73–80.
- Léchappé, V., De Leon, J., Moulay, E., Plestan, F., & Glumineau, A. (2018). Delay and state observation for SISO nonlinear systems with input delay. *International Journal of Robust and Nonlinear Control*, 28(6), 2356–2368.
- Léchappé, V., Moulay, E., & Plestan, F. (2016). Dynamic observation-prediction for LTI systems with a time-varying delay in the input. In *Proceedings of the 55th IEEE Conference on Decision and Control (CDC)* (pp. 2302–2307). Las Vegas, NV, USA.
- Léchappé, V., Moulay, E., & Plestan, F. (2018). Prediction-based control for LTI systems with uncertain time-varying delays and partial state knowledge. *International Journal of Control*, 91(6), 1403–1414.
- Léchappé, V., Moulay, E., & Plestan, F. (2018). Prediction-based control of LTI systems with input and output time-varying delays. *Systems & Control Letters*, 112, 24–30.
- Léchappé, V., Moulay, E., Plestan, F., Glumineau, A., & Chriette, A. (2015). New predictive scheme for the control of LTI systems with input delay and unknown disturbances. *Automatica*, 52, 179–184.
- Léchappé, V., Moulay, E., Plestan, F., & Han, Q.-L. (2019). Discrete predictor-based event-triggered control of networked control systems. *Automatica*, 107, 281–288.
- Léchappé, V., Rouquet, S., Gonzalez, A., Plestan, F., De León, J., Moulay, E., & Glumineau, A. (2016). Delay estimation and predictive control of uncertain systems with input delay: Application to a DC motor. *IEEE Transactions on Industrial Electronics*, 63(9), 5849–5857.
- Leonard, F., & Abba, G. (2011). Robustness and safe sampling of distributed-delay control laws for unstable delayed systems. *IEEE transactions on automatic control*, 57(6), 1521–1526.
- Lhachemi, H., Prieur, C., & Shorten, R. (2019). An LMI condition for the robustness of constant-delay linear predictor feedback with respect to uncertain time-varying input delays. *Automatica*, 109(108551).
- Lhachemi, H., Prieur, C., & Shorten, R. (2020). Robustness of constant-delay predictor feedback with respect to distinct uncertain time-varying input delays. In *Proceedings of the 21st IFAC World Congress* (pp. 7677–7682). Berlin, Germany: Elsevier.
- Lhachemi, H., Prieur, C., & Shorten, R. (2021). Robustness of constant-delay predictor feedback for in-domain stabilization of reaction-diffusion PDEs with time-and spatially-varying input delays. *Automatica*, 123(109347).
- Li, Z.-Y., Zhou, B., & Lin, Z. (2014). On robustness of predictor feedback control of linear systems with input delays. *Automatica*, 50(5), 1497–1506.
- Lin, Z. (1999). *Low gain feedback*. London, UK: Springer.
- Lin, Z., & Fang, H. (2007). On Asymptotic Stabilizability of Linear Systems With Delayed Input. *IEEE Transactions on Automatic Control*, 52(6), 998–1013.
- Liu, K., & Fridman, E. (2014). Delay-dependent methods and the first delay interval. *System & Control Letters*, 64, 57–53.
- Liu, K., Selivanov, A., & Fridman, E. (2019). Survey on time-delay approach to networked control. *Annual Reviews in Control*, 48, 57–79.
- Liu, K.-Z., & Sun, X.-M. (2018). Stabilization of nonlinear systems with time-varying input and state delays by approximate predictor. *IEEE Transactions on Automatic Control*, 63(10), 3449–3455.
- Liu, Q. (2020). Observer-predictor feedback for consensus of discrete-time multiagent systems with both state and input delays. *International Journal of Robust and Nonlinear Control*, 30(10), 4003–4021.
- Liu, Q. (2021). Pseudo-predictor feedback control for multiagent systems with both state and input delays. *IEEE/CAA Journal of Automatica Sinica*, 8(11), 1827–1836.
- Loukianov, A., Caballero-Barragán, H., Osuna-Ibarra, L., Espinosa-Guerra, O., & Castillo-Toledo, B. (2017). Robust control for uncertain linear delay systems via sliding mode control. *International Journal of Robust and Nonlinear Control*, 27(18), 4825–4845.
- Lozano, R., Castillo, P., Garcia, P., & Dzul, A. (2004). Robust prediction-based control for unstable delay systems: Application to the yaw control of a mini-helicopter. *Automatica*, 40(4), 603–612.
- Ma, Y., He, X., Chen, M., & He, W. (2021). Predictor-based control for a flexible satellite subject to output time delay. *IEEE Transactions on Control Systems Technology*(Early Access). (doi: 10.1109/TCST.2021.3109270)

- Malisoff, M., & Mazenc, F. (2018). Sequential predictors for linear time-varying systems with delays in the vector field and in the input. In *Proceedings of the 57th IEEE Conference on Decision and Control (CDC)* (pp. 6246–6249). Miami, FL, USA.
- Manitius, A. Z., & Olbrot, A. Z. (1979). Finite spectrum assignment problem for systems with delays. *IEEE Transactions on Automatic Control*, *24*(4), 541–552.
- Mattioni, M., Monaco, S., & Normand-Cyrot, D. (2018). Nonlinear discrete-time systems with delayed control: A reduction. *Systems & Control Letters*, *114*, 31–37.
- Mattioni, M., Monaco, S., & Normand-Cyrot, D. (2020). IDA-PBC for LTI dynamics under input delays: a reduction approach. *IEEE Control Systems Letters*, *5*(4), 1465–1470.
- Mazenc, F., & Fridman, E. (2014). Predictor-based sampled-data stabilization via continuous-discrete observers. In *Proceedings of the 53rd IEEE Conference on Decision and Control (CDC)* (pp. 1614–1619). Los Angeles, CA, USA.
- Mazenc, F., & Fridman, E. (2016). Predictor-based sampled-data exponential stabilization through continuous-discrete observers. *Automatica*, *63*, 74–81.
- Mazenc, F., & Malisoff, M. (2015). Trajectory based approach for the stability analysis of nonlinear systems with time delays. *IEEE Transactions on Automatic Control*, *60*(6), 1716–1721.
- Mazenc, F., & Malisoff, M. (2016). New prediction approach for stabilizing time-varying systems under time-varying input delay. In *Proceedings of the 55th IEEE Conference on Decision and Control (CDC)* (pp. 3178–3182). Las Vegas, NV, USA.
- Mazenc, F., & Malisoff, M. (2017a). Stabilization and robustness analysis for time-varying systems with time-varying delays using a sequential subpredictors approach. *Automatica*, *82*, 118–127.
- Mazenc, F., & Malisoff, M. (2017b). Stabilization of nonlinear time-varying systems through a new prediction based approach. *IEEE Transactions on Automatic Control*, *62*(6), 2908–2915.
- Mazenc, F., & Malisoff, M. (2018). Continuous-discrete sequential observers under sampling and input delays. In *Proceedings of the 2018 American Control Conference (ACC)* (pp. 5156–5160). Milwaukee, WI, USA.
- Mazenc, F., & Malisoff, M. (2020a). Continuous discrete sequential observers for time-varying systems under sampling and input delays. *IEEE Transactions on Automatic Control*, *65*(4), 1704–1709.
- Mazenc, F., & Malisoff, M. (2020b). Sequential predictors for delay compensation for perturbed discrete time systems. In *Proceedings of the 2020 American Control Conference (ACC)* (pp. 1696–1700). Denver, CO, USA.
- Mazenc, F., Malisoff, M., & Bhogaraju, I. N. S. (2020). Sequential predictors for delay compensation for discrete time systems with time-varying delays. *Automatica*, *112*(109188).
- Michiels, W., Mondié, S., & Roose, D. (2003). Necessary and sufficient conditions for a safe implementation of distributed delay control laws. In *Proceedings of the joint CNRS-NSF Workshop: Advances in Time-Delay Systems* (pp. 1–6). Paris, France.
- Michiels, W., & Niculescu, S.-I. (2003). On the delay sensitivity of smith predictors. *International journal of systems science*, *34*(8–9), 543–551.
- Mondié, S., & Michiels, W. (2003). Finite spectrum assignment of unstable time-delay systems with a safe implementation. *IEEE Transactions on Automatic Control*, *48*(12), 2207–2212.
- Mondié, S., Niculescu, S.-I., & Loiseau, J. (2001). Delay robustness of closed loop finite assignment for input delay systems. In *Proceedings of the 3rd IFAC Workshop on Time Delay Systems* (pp. 207–212). Santa Fe, NM, USA: Elsevier.
- Moulay, E., Dambrine, M., Yeganefar, N., & Perruquetti, W. (2008). Finite-time stability and stabilization of time-delay systems. *System & Control Letters*, *57*(7), 561–566.
- Mukherjee, K., Kar, I., & Bhatt, R. (2015). Region tracking based control of an autonomous underwater vehicle with input delay. *Ocean Engineering*, *99*, 107–114.
- Najafi, M., Hosseinnia, S., Sheikholeslam, F., & Karimadini, M. (2013). Closed-loop control of dead time systems via sequential sub-predictors. *International Journal of Control*, *86*(4), 599–609.
- Najafi, M., Sheikholeslam, F., Wang, Q.-G., & Hosseinnia, S. (2014). Robust  $h_\infty$  control of single input-delay systems based on sequential sub-predictors. *IET Control Theory & Applications*, *8*(13), 1175–1184.
- Nandiganahalli, J. S., Kwon, C., & Hwang, I. (2019). Delay-tolerant adaptive robust tracking control of uncertain time-delay systems. *IEEE Transactions on Automatic Control*, *65*(2), 695–710.
- Nguyen, K.-D., & Dankowicz, H. (2019). Input-delay compensation in a robust adaptive control framework. *IET Control Theory & Applications*, *13*(11), 1718–1727.

- Nihtilä, M. T. (1989). Adaptive control of a continuous-time system with time-varying input delay. *Systems & Control Letters*, 12(4), 357–364.
- Nihtilä, M. T. (1991). Finite pole assignment for systems with time-varying input delays. In *Proceedings of the 30th IEEE Conference on Decision and Control (CDC)* (pp. 927–928). Brighton, UK: IEEE.
- Novella-Rodríguez, D. F., Witrant, E., del Muro-Cuéllar, B., & Márquez-Rubio, J. F. (2019). Adaptive multi-observer design for systems with unknown long input delay. *IFAC-PapersOnLine*, 52(18), 37–42.
- Nozari, E., Tallapragada, P., & Cortés, J. (2020). Event-triggered stabilization of nonlinear systems with time-varying sensing and actuation delay. *Automatica*, 113(108754).
- Oh, S.-Y., & Choi, H.-L. (2020). Adaptive control of feedforward nonlinear systems with uncertain time-varying parameters and an unknown time-varying delay in the input. *International Journal of Adaptive Control and Signal Processing*, 34(9), 1308–1320.
- Olfati-Saber, R., & Murray, R. M. (2004). Consensus problems in networks of agents with switching topology and time-delays. *IEEE Transactions on Automatic Control*, 49(9), 1520–1533.
- Osuna-Ibarra, L. P., Caballero-Barragan, H., & Loukianov, A. (2020). Predictor-based control for nonlinear mechanical systems with measurement delay. In *Proceedings of the 21st IFAC World Congress* (pp. 5783–5788). Berlin, Germany: Elsevier.
- Peng, X., Zhou, Y., Yu, J., Guo, K., & Geng, Z. (2021). Predictor-based pose stabilization control for unmanned vehicles on SE (3) with actuator delay and saturation. *Aerospace Science and Technology*, 117(106942).
- Pepe, P., Pola, G., & Di Benedetto, M. D. (2017). On Lyapunov-Krasovskii characterizations of stability notions for discrete-time systems with uncertain time-varying time delays. *IEEE Transactions on Automatic Control*, 63(6), 1603–1617.
- Polyakov, A. (2011). Nonlinear feedback design for fixed-time stabilization of linear control systems. *IEEE Transactions on Automatic Control*, 57(8), 3344–3349.
- Polyakov, A., Efimov, D., Perruquetti, W., & Richard, J.-P. (2013). Output stabilization of time-varying input delay systems using interval observation technique. *Automatica*, 49(11), 3402–3410.
- Ponomarev, A., Chen, Z., & Zhang, H.-T. (2018). Discrete-time predictor feedback for consensus of multiagent systems with delays. *IEEE Transactions on Automatic Control*, 63(2), 498–504.
- Popescu, D., & Rasvan, V. (2004). Robustness properties of a control procedure for systems with input delay. In *Proceedings of the 12th IEEE Mediterranean Electrotechnical Conference* (pp. 391–394). Dubrovnik, Croatia.
- Qi, J., Wang, S., Fang, J.-a., & Diagne, M. (2019). Control of multi-agent systems with input delay via PDE-based method. *Automatica*, 106, 91–100.
- Qiu, T., Alibejji, N., & Sharma, N. (2016). Robust compensation of electromechanical delay during neuromuscular electrical stimulation of antagonistic muscles. In *Proceedings of the 2016 American Control Conference (ACC)* (pp. 4871–4876). Boston, MA, USA.
- Richard, J.-P. (2003). Time-delay systems: an overview of some recent advances and open problems. *Automatica*, 39(10), 1667–1694.
- Roh, Y.-H. (2002). Robust stability of predictor-based control systems with delayed control. *International Journal of Systems Science*, 33(2), 81–86.
- Santos, O., & Mondié, S. (2000). Control laws involving distributed time delays: Robustness of the implementation. In *Proceedings of the 2000 American Control Conference (ACC)* (pp. 2479–2480). Chicago, IL, USA.
- Santos, T. L. (2016). Modified Artstein predictor for LTI systems with dead time and unknown disturbances. *Journal of Control, Automation and Electrical Systems*, 27(3), 263–273.
- Sanz, R., Garcia, P., & Albertos, P. (2016). Enhanced disturbance rejection for a predictor-based control of lti systems with input delay. *Automatica*, 72, 205–208.
- Sanz, R., Garcia, P., Albertos, P., & Zhong, Q.-C. (2017). Robust controller design for input-delayed systems using predictive feedback and an uncertainty estimator. *International Journal of Robust and Nonlinear Control*, 27(10), 1826–1840.
- Sanz, R., García, P., Fridman, E., & Albertos, P. (2017). A predictive extended state observer for a class of nonlinear systems with input delay subject to external disturbances. In *Proceedings of*

- the 56th IEEE Conference on Decision and Control (CDC) (pp. 4345–4350). Melbourne, VIC, Australia.
- Sanz, R., Garcia, P., Fridman, E., & Albertos, P. (2018). Rejection of mismatched disturbances for systems with input delay via a predictive extended state observer. *International Journal of Robust and Nonlinear Control*, 28(6), 2457–2467.
- Sanz, R., García, P., Fridman, E., & Albertos, P. (2020). Robust predictive extended state observer for a class of nonlinear systems with time-varying input delay. *International Journal of Control*, 93(2), 217–225.
- Selivanov, A., & Fridman, E. (2016a). Observer-based input-to-state stabilization of networked control systems with large uncertain delays. *Automatica*, 74, 63–70.
- Selivanov, A., & Fridman, E. (2016b). Predictor-based networked control under uncertain transmission delays. *Automatica*, 70, 101–108.
- Seuret, A., & Gouaisbaut, F. (2013). Wirtinger-based integral inequality: application to time-delay systems. *Automatica*, 49(9), 2860–2866.
- Seuret, A., & Gouaisbaut, F. (2015). Hierarchy of LMI conditions for the stability analysis of time-delay systems. *Systems & Control Letters*, 81, 1–7.
- Sharma, N., Bhasin, S., Wang, Q., & Dixon, W. E. (2011). Predictor-based control for an uncertain Euler-Lagrange system with input delay. *Automatica*, 47(11), 2332–2342.
- Sharma, N., Gregory, C. M., & Dixon, W. E. (2011). Predictor-based compensation for electromechanical delay during neuromuscular electrical stimulation. *IEEE Transactions on Neural Systems and Rehabilitation Engineering*, 19(6), 601–611.
- Sheng, Z., Sun, Z., Molazadeh, V., & Sharma, N. (2021). Switched control of an N-degree-of-freedom input delayed wearable robotic system. *Automatica*, 125(109455).
- Shi, S., Liu, W., Lu, J., & Chu, Y. (2018). Improved disturbance rejection for predictor-based control of MIMO linear systems with input delay. *International Journal of Systems Science*, 49(3), 653–661.
- Shi, S., Xu, S., Gu, J., & Zhang, Z. (2021). Robust exact predictive scheme for output-feedback control of input-delay systems with unmatched sinusoidal disturbances. *IEEE Transactions on Systems, Man, and Cybernetics: Systems*, 51(9), 5357–5366.
- Shi, S., Xu, S., Li, Y., Chu, Y., & Zhang, Z. (2018). Robust predictive scheme for input delay systems subject to nonlinear disturbances. *Nonlinear Dynamics*, 93(3), 1035–1045.
- Slotine, J.-J. E., & Li, W. (1991). *Applied nonlinear control*. New Jersey, USA: Prentice-Hall International Editions.
- Smith, O. J. (1959). A controller to overcome dead time. *ISA Journal*, 6, 28–33.
- Sun, J., Yang, J., & Zeng, Z. (2022). Predictor-based periodic event-triggered control for nonlinear uncertain systems with input delay. *Automatica*, 136(110055).
- Sun, X.-M., Liu, K.-Z., Wem, C., & Wang, W. (2016). Predictive control of nonlinear continuous networked control systems with large time-varying transmission delays and transmission protocols. *Automatica*, 64, 76–85.
- Tao, G. (1997). A simple alternative to the Barbalat Lemma. *IEEE Transactions on Automatic Control*, 42(5), 698.
- Teng, X., & Yamashita, Y. (2011). Novel ODE-type nonlinear smith predictor for networked control systems with time-varying delay. In *Proceedings of the 19th Mediterranean Conference on Control & Automation (MED)* (pp. 19–24). Corfu, Greece.
- Van Assche, V., Dambrine, M., Lafay, J.-F., & Richard, J.-P. (1999). Some problems arising in the implementation of distributed-delay control laws. In *Proceedings of the 38th IEEE Conference on Decision and Control* (pp. 4668–4672). Phoenix, AZ, USA.
- Wang, C., Zuo, Z., Lin, Z., & Ding, Z. (2016). A truncated prediction approach to consensus control of lipschitz nonlinear multiagent systems with input delay. *IEEE Transactions on Control of Network Systems*, 4(4), 716–724.
- Wang, S., Diagne, M., & Qi, J. (2021). Delay-adaptive predictor feedback control of Reaction-Advection-Diffusion PDEs with a delayed distributed input. *IEEE Transactions on Automatic Control*(Early Access). (doi: 10.1109/TAC.2021.3109512)
- Wang, S., Qi, J., & Diagne, M. (2021). Adaptive boundary control of reaction-diffusion PDEs with unknown input delay. *Automatica*, 134(109909).

- Wang, X., Liu, J., & Cai, K.-Y. (2009). Tracking control for a velocity-sensorless VTOL aircraft with delayed outputs. *Automatica*, *45*(12), 2876–2882.
- Wang, Y., & Wu, A.-G. (2019). A modified predictive scheme for disturbances attenuation of LTI systems with input delay. In *Proceedings of the 2019 Chinese Control Conference (CCC)* (pp. 1297–1300). Guangzhou, China.
- Wang, Y.-L., & Han, Q.-L. (2017). Network-based heading control and rudder oscillation reduction for unmanned surface vehicles. *IEEE Transactions on Control Systems Technology*, *25*(5), 1609–1620.
- Wang, Z. (2021). Consensus analysis for high-order discrete-time agents with time-varying delay. *International Journal of Systems Science*, *52*(5), 1003–1013.
- Watanabe, K., & Ito, M. (1981). A process-model control for linear systems with delay. *IEEE Transactions on Automatic control*, *26*(6), 1261–1269.
- Wei, Y., & Lin, Z. (2015). On the delay bounds of linear systems under delay independent truncated predictor feedback: The state feedback case. In *Proceedings of the 54th IEEE Conference on Decision and Control (CDC)* (pp. 4642–4647). Osaka, Japan: IEEE.
- Wei, Y., & Lin, Z. (2016). Stabilization of exponentially unstable linear systems with multiple input delays by truncated predictor feedback. In *Proceedings of the 35th Chinese Control Conference (CCC)* (pp. 1621–1626). Chengdu, China: IEEE.
- Wei, Y., & Lin, Z. (2017a). Delay independent truncated predictor feedback for stabilization of linear systems with multiple time-varying input delays. In *Proceedings of the 2017 American Control Conference (ACC)* (pp. 5732–5737). Seattle, WA, USA: IEEE.
- Wei, Y., & Lin, Z. (2017b). Maximum delay bounds of linear systems under delay independent truncated predictor feedback. *Automatica*, *83*, 65–72.
- Wei, Y., & Lin, Z. (2018). A delay-independent output feedback for linear systems with time-varying input delay. *International Journal of Robust and Nonlinear Control*, *28*(8), 2950–2960.
- Wei, Y., & Lin, Z. (2019a). Regulation of linear input delayed systems without delay knowledge. *SIAM Journal on Control and Optimization*, *57*(2), 999–1022.
- Wei, Y., & Lin, Z. (2019b). Time-varying low gain feedback for linear systems with unknown input delay. *Systems & Control Letters*, *123*, 98–107.
- Wei, Y., & Lin, Z. (2020). Delay independent output feedback stabilization of discrete-time linear systems with bounded input delay. In *Proceedings of the 2020 American Control Conference (ACC)* (pp. 1701–1706). Denver, CO, USA: IEEE.
- Wei, Y., & Lin, Z. (2021). A delay-independent output feedback law for discrete-time linear systems with bounded unknown input delay. *International Journal of Robust and Nonlinear Control*, *31*(5), 1735–1754.
- Witrant, E., Canudas-de Wit, C., Georges, D., & Alamir, M. (2004). Remote stabilization via time-varying communication network delays: application to TCP networks. In *Proceedings of the 2004 IEEE International Conference on Control Applications (CCA)* (pp. 474–479). Taipei, Taiwan, China: IEEE.
- Witrant, E., Canudas-de Wit, C., Georges, D., & Alamir, M. (2007). Remote stabilization via communication networks with a distributed control law. *IEEE Transactions on Automatic control*, *52*(8), 1480–1485.
- Xie, Y., Wei, Y., & Lin, Z. (2020). Stabilization of linear systems with time-varying input delay by event-triggered delay independent truncated predictor feedback. *International Journal of Robust and Nonlinear Control*, *30*(13), 5134–5156.
- Yan, Y., & Chen, Z. (2019). Cooperative output regulation of linear discrete-time time-delay multi-agent systems by adaptive distributed observers. *Neurocomputing*, *331*, 33–39.
- Yang, H., Guo, X., Dai, L., & Xia, Y. (2017). Event-triggered predictive control for networked control systems with network-induced delays and packet dropouts. *International Journal of Robust and Nonlinear Control*, *28*(4), 1350–1365.
- Yang, R., & Zheng, W. X. (2019). Output-based event-triggered predictive control for networked control systems. *IEEE Transactions on Industrial Electronics*, *67*(12), 10631–10640.
- Yang, X., & Zhou, B. (2017). Memoryless feedback control of discrete-time systems with multiple time-varying actuator delays. In *Proceedings of the 2017 Chinese Automation Congress (CAC)* (pp. 6953–6958). Jinan, China: IEEE.

- Yang, X., & Zhou, B. (2019). Consensus of discrete-time multiagent systems with input delays by truncated pseudo-predictor feedback. *IEEE Transactions on Cybernetics*, *49*(2), 505–516.
- Yi, J., Zhang, Y., & Song, D. (2009). Autonomous motorcycles for agile maneuvers, part II: control systems design. In *Proceedings of the 48th IEEE Conference on Decision and Control (CDC)* (pp. 4619–4624). Shanghai, China.
- Zhan, G., Du, D., & Fei, M. (2017). Stability and stabilization for visual servo inverted pendulum system with random image processing time delay. In *Proceedings of the 43rd Annual Conference of the IEEE Industrial Electronics Society (IECON 2017)* (pp. 4325–4330).
- Zhang, J., Pan, L., Han, Q.-L., Chen, C., Wen, S., & Xiang, Y. (2022). Deep learning based attack detection for cyber-physical system cybersecurity: A survey. *IEEE/CAA Journal of Automatica Sinica*, *9*(3), 377–391.
- Zhang, X.-M., Han, Q.-L., & Ge, X. (2021). The construction of augmented Lyapunov-Krasovskii functionals and the estimation of their derivatives in stability analysis of time-delay systems: a survey. *International Journal of Systems Science*(Early Access). (doi: 10.1080/00207721.2021.2006356)
- Zhang, X.-M., Han, Q.-L., Ge, X., & Ding, D. (2018). An overview of recent developments in Lyapunov-Krasovskii functionals and stability criteria for recurrent neural networks with time-varying delays. *Neurocomputing*, *313*, 392–401.
- Zhang, X.-M., Han, Q.-L., Ge, X., Ding, D., Ding, L., Yue, D., & Peng, C. (2020). Networked control systems: A survey of trends and techniques. *IEEE/CAA Journal of Automatica Sinica*, *7*(1), 1–17.
- Zhang, X.-M., Han, Q.-L., Seuret, A., Gouaisbaut, F., & He, Y. (2019). Overview of recent advances in stability of linear systems with time-varying delays. *IET Control Theory & Applications*, *13*(1), 1–16.
- Zhang, Z., Zhou, B., & Michiels, W. (2021). Pseudo predictor feedback stabilisation of linear systems with both state and input delays. *International Journal of Control*, *94*(11), 3135–3145.
- Zhong, Q.-C. (2004). On distributed delay in linear control laws-part I: discrete-delay implementations. *IEEE Transactions on Automatic Control*, *49*(11), 2074–2080.
- Zhou, B. (2014a). Pseudo-predictor feedback stabilization of linear systems with time-varying input delays. *Automatica*, *50*(11), 2861–2871.
- Zhou, B. (2014b). *Truncated predictor feedback for time-delay systems*. Berlin, Germany: Springer-Verlag Berlin Heidelberg.
- Zhou, B., & Cong, S. (2016). Stabilisation and consensus of linear systems with multiple input delays by truncated pseudo-predictor feedback. *International Journal of Systems Science*, *47*(2), 328–342.
- Zhou, B., & Li, Z.-Y. (2015). Truncated predictor feedback for periodic linear systems with input delays with applications to the elliptical spacecraft rendezvous. *IEEE Transactions on Control Systems Technology*, *23*(6), 2238–2250.
- Zhou, B., Li, Z.-Y., & Lin, Z. (2013). Stabilization of discrete-time systems with multiple actuator delays and saturations. *IEEE Transactions on Circuits and Systems I: Regular Papers*, *60*(2), 389–400.
- Zhou, B., & Lin, Z. (2014a). Consensus of high-order multi-agent systems with large input and communication delays. *Automatica*, *50*(2), 452–464.
- Zhou, B., & Lin, Z. (2014b). Truncated predictor feedback stabilization of polynomially unstable linear systems with multiple time-varying input delays. *IEEE Transactions on Automatic Control*, *59*(8), 2157–2163.
- Zhou, B., Lin, Z., & Duan, G.-R. (2012). Truncated predictor feedback for linear systems with long time-varying input delays. *Automatica*, *48*(10), 2387–2399.
- Zhou, B., Michiels, W., & Chen, J. (2021). Fixed-time stabilization of linear delay systems by smooth periodic delayed feedback. *IEEE Transactions on Automatic Control*(Early Access). (doi: 10.1109/TAC.2021.3051262)
- Zhou, B., Sang, Q., & Lin, Z. (2013). Sampled-data periodic predictor feedback for linear systems with input delay. In *Proceedings of the 32nd Chinese Control Conference (CCC)* (pp. 1409–1414). Xi’an, China: IEEE.



- Zhu, Y., & Fridman, E. (2019). Decentralized predictor feedback of large-scale systems under input delays. In *Proceedings of the IEEE 58th Conference on Decision and Control (CDC)* (pp. 4642–4647). Nice, France.
- Zhu, Y., & Fridman, E. (2020a). Decentralized predictor output feedback for large-scale systems with large delays. In *Proceedings of the 21st IFAC World Congress* (pp. 7527–7532). Berlin, Germany: Elsevier.
- Zhu, Y., & Fridman, E. (2020b). Observer-based decentralized predictor control for large-scale interconnected systems with large delays. *IEEE Transactions on Automatic Control*, *66*(6), 2897–2904.
- Zhu, Y., & Fridman, E. (2020c). Predictor methods for decentralized control of large-scale systems with input delays. *Automatica*, *116*(108903).
- Zhu, Y., & Fridman, E. (2021). Sub-predictors for network-based control under uncertain large delays. *Automatica*, *123*(109350).
- Zhu, Y., Krstic, M., & Su, H. (2017). Adaptive output feedback control for uncertain linear time-delay systems. *IEEE Transactions on Automatic Control*, *62*(2), 545–560.
- Zhu, Y., Krstic, M., & Su, H. (2018). PDE boundary control of multi-input LTI systems with distinct and uncertain input delays. *IEEE Transactions on Automatic Control*, *63*(12), 4270–4277.
- Zhu, Y., Krstic, M., & Su, H. (2020). Predictor feedback for uncertain linear systems with distributed input delays. *IEEE Transactions on Automatic Control*, *65*(12), 5344–5351.
- Zhu, Y., Su, H., & Krstic, M. (2015). Adaptive backstepping control of uncertain linear systems under unknown actuator delay. *Automatica*, *54*, 256–265.
- Zuo, Z., Lin, Z., & Ding, Z. (2016). Truncated predictor control of Lipschitz nonlinear systems with time-varying input delay. *IEEE Transactions on Automatic Control*, *62*(10), 5324–5330.