



ISEN
ALL IS DIGITAL!



Selecting Hyperspectral bands for Leaf Mass per Area Prediction by Means of Neural Networks

Catherine Baskiotis, Josselin Aval, Marwa El Bouz, Ayman Alfalou
Light Scattering Learning Group, **L@bisen**, ISEN, Yncréa-Ouest, Brest, France

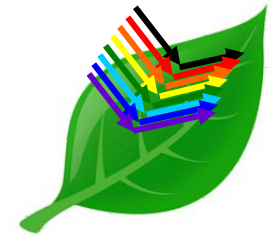

contact : catherine.baskiotis@isen-ouest.yncrea.fr

Leaf Mass per Area (LMA) definition

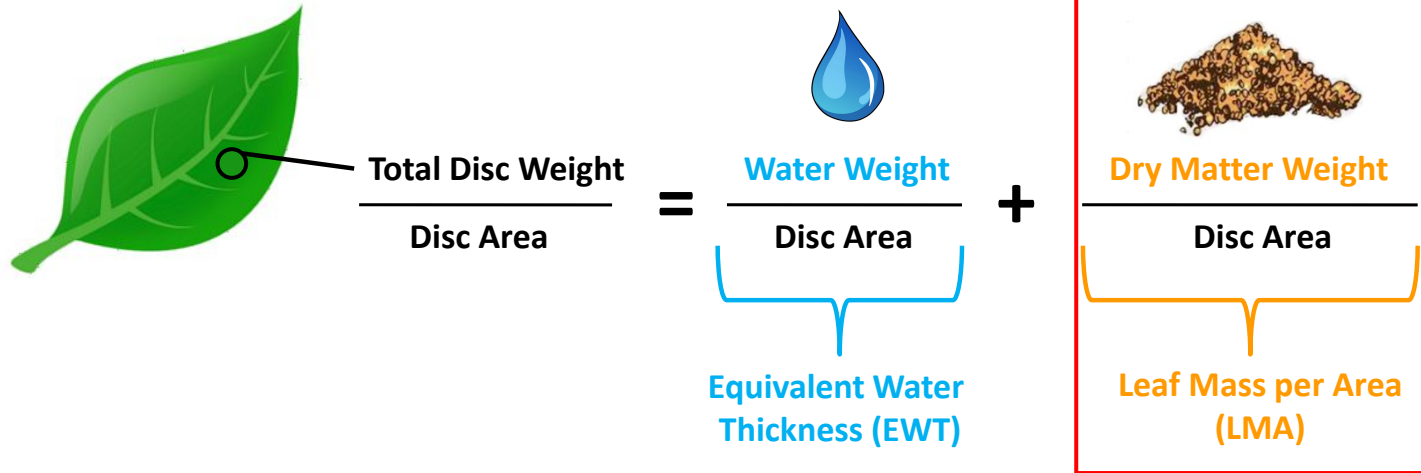

Leaf Mass per Area hyperspectral monitoring applications

- ✓ Precision Agriculture (Fertilizer management, Early detection of plant diseases, etc)
- ✓ Global environmental watching



■ Open question:

How much can we reduce the number of hyperspectral bands while keeping a good accuracy for LMA prediction ?

■ Literature answers:

- ✓ Physics-based PROSPECT model: ~100 hyperspectral bands [1]
Currently offering the best accuracy for LMA prediction, Relative RMSE ~18%
- ✓ Vegetation indices: 2 to 6 hyperspectral bands [2,3]
Poor LMA prediction accuracy, Relative RMSE ~28%
- ✓ Partial Least Square Regression (PLSR): ~15 hyperspectral bands [2]
Very poor LMA prediction accuracy, Relative RMSE ~38%

$$\text{Relative Root Mean Square Error (RMSE)} = \frac{\text{Root Mean Square Error (RMSE)}}{\text{LMA mean value over the tested database}}$$

- [1] J.-B. Féret et al., *Remote Sensing of Environment*, **231**, pp. 110959, 2019.
[2] Y. Chen et al., *Remote Sensing*, **13**, pp. 3761, 2021.
[3] G. le Maire et al., *Remote Sensing of Environment*, **112**, pp. 3846-3864, 2008

■ Open question:

How much can we reduce the number of hyperspectral bands while keeping a good accuracy for LMA prediction ?

■ Literature answers:

- ✓ Physics-based PROSPECT model: **~100 hyperspectral bands** [1]
Currently offering the best accuracy for LMA prediction, Relative RMSE ~18%
- ✓ Vegetation indices: **2 to 6 hyperspectral bands** [2,3]
Poor LMA prediction accuracy, Relative RMSE ~28%
- ✓ Partial Least Square Regression (PLSR): **~15 hyperspectral bands** [2]
Very poor LMA prediction accuracy, Relative RMSE ~38%

- Study goal: **To improve the accuracy of LMA prediction with a small number of bands (<15)**

Outline

1. Introduction

→ 2. Material

3. Band selection by means of neural networks

4. Results

5. Conclusions and perspectives

Material

- Publicly Available *Angers* dataset

- ✓ 274 samples
- ✓ 2050 hyperspectral bands

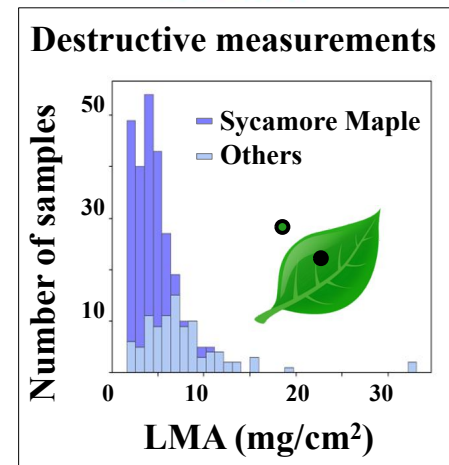
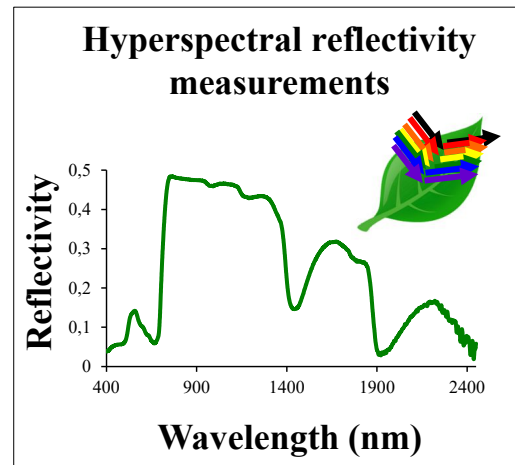

Material

- Publicly Available *Angers* dataset

- ✓ 274 samples
- ✓ 2050 hyperspectral bands

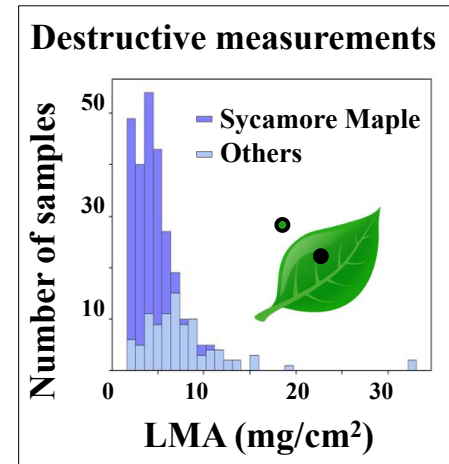
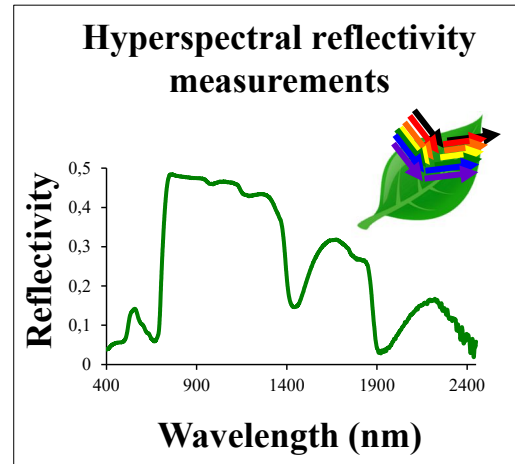

- Hyperspectral signal characteristics

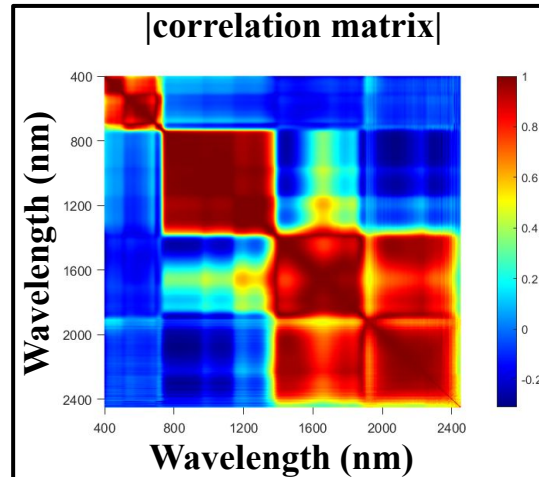

■ Limitations of AI state-of-the-art band selection methods

✓ Unsupervised methods

- Main methods : Principal Component Analysis, Distance-based methods, Similarity-based methods, Bands Mutual Information-based methods
- Principle : Inter-bands relationships investigation **ignoring the relationships between the bands and the output**
- Proven efficiency in numerous classification problems
- Poor accuracy in regression problems

✓ Supervised methods

- Main method : Band-Output Mutual Information-based method
- Principle : Investigation of the relationships between bands and output
- Proven efficiency in classification problems (where the output is the class)
- No straightforward adaptation to regression problems (Binning, Kraskov's method,...)

Band selection algorithm

Step 1: Band weight computation [Yacoub et Bennani, IJNS, 2000]

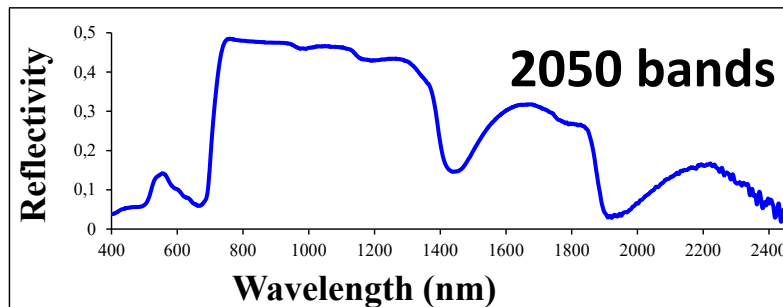
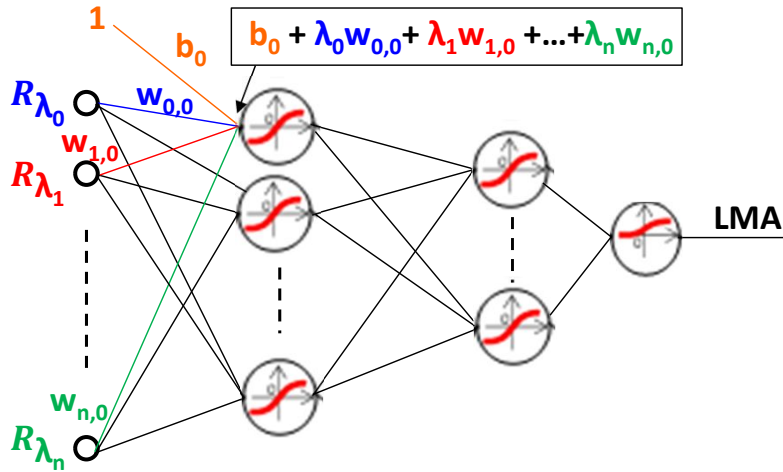

$$Weight(i) = \sum_{(j \in \text{layer } 1)} \frac{w_{ij}}{\sum_{(k \in \text{layer } 0)} w_{kj}} \pi_{j,out}$$

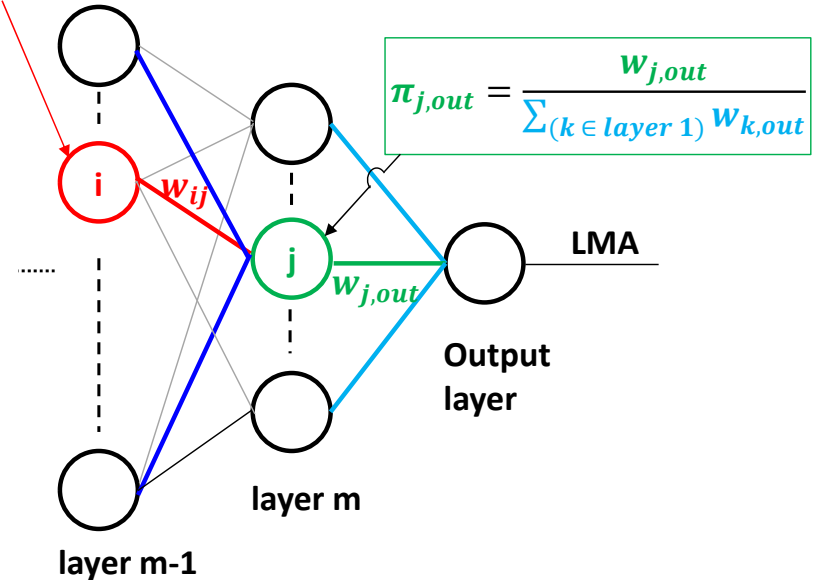

[Yacoub et Bennani, IJNS, 2000] M. Yacoub, Y. Bennani, "Features selection and architecture optimization in connectionist systems", *International Journal of Neural Systems*, **10**, pp. 379-95, 2000.

Band selection algorithm

Step 1: Band weight computation [Yacoub et Bennani, IJNS, 2000]

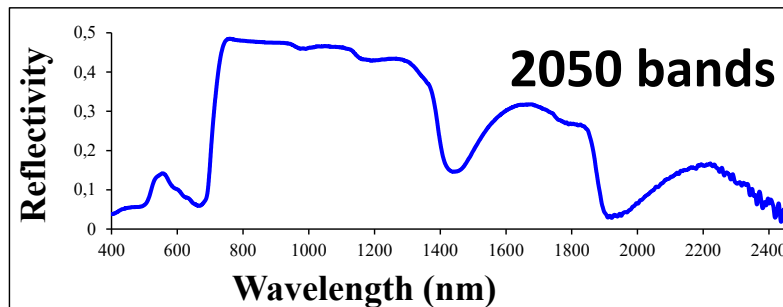
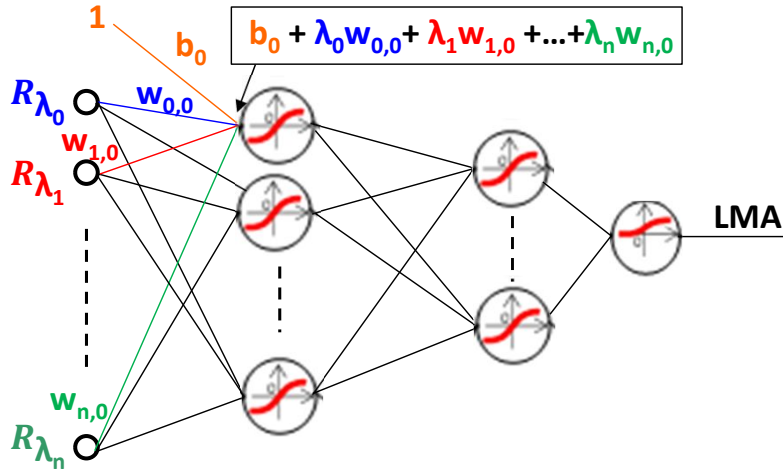

Weight

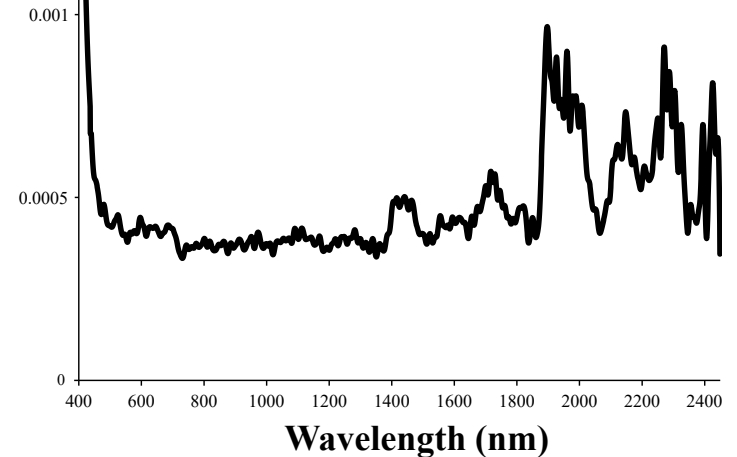

Band selection algorithm

Step 1: Band weight computation [Yacoub et Bennani, IJNS, 2000]

Step 2: P peaks selection

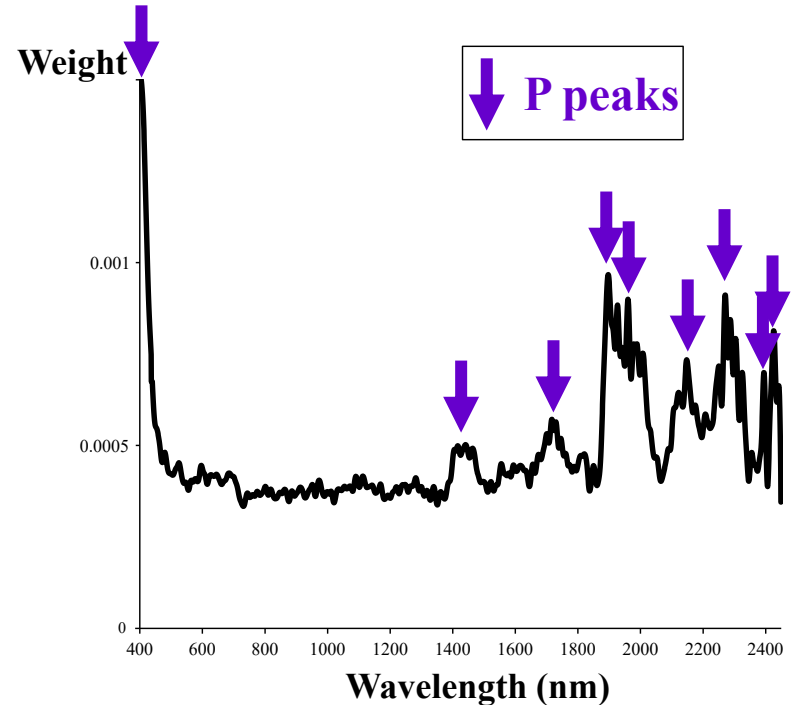
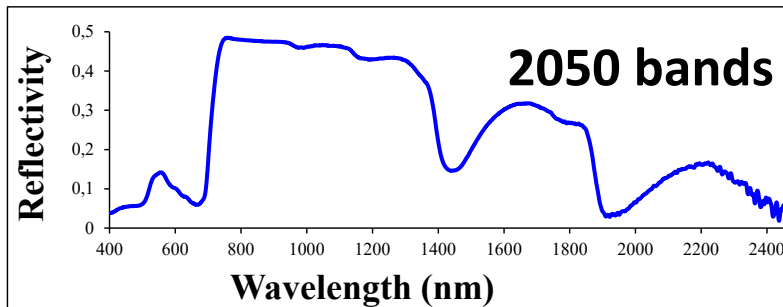

Band selection algorithm

Step 1: Band weight computation [Yacoub et Bennani, IJNS, 2000]

Step 2: P peaks selection

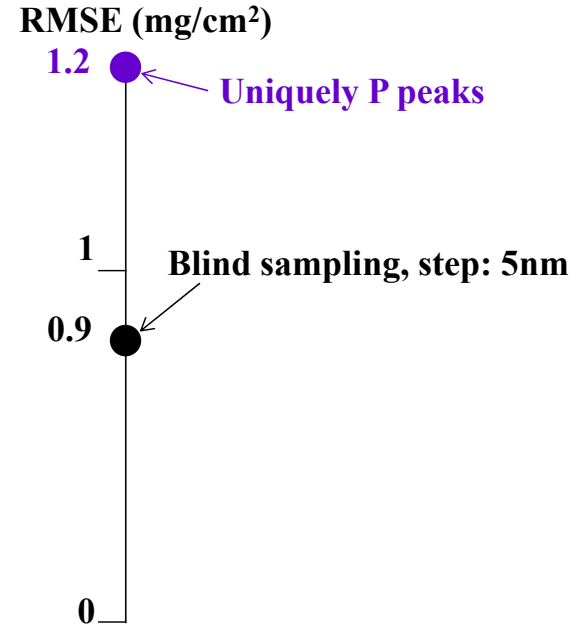
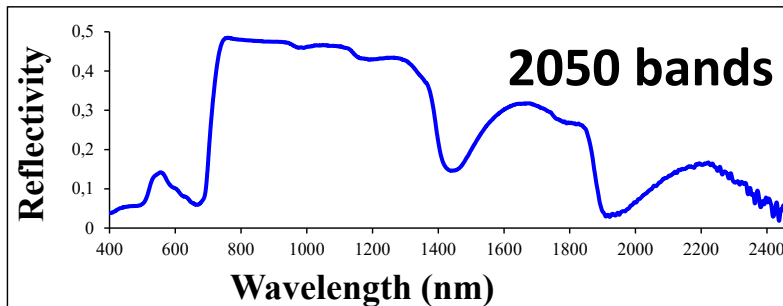

Band selection algorithm

Step 1: Band weight computation [Yacoub et Bennani, IJNS, 2000]

Step 2: P peaks selection

Step 3: Sampling step choice



Congregation of P peaks and
sampled bands
~50 bands

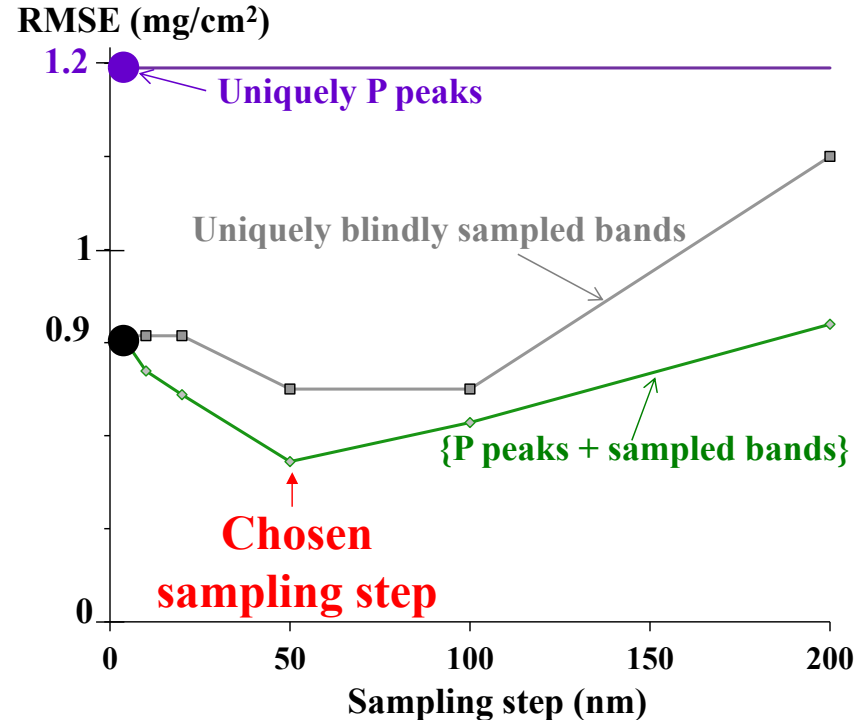
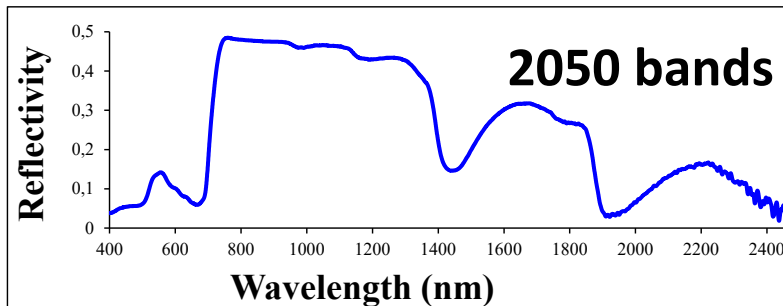

Band selection algorithm

Step 1: Band weight computation [Yacoub et Bennani, IJNS, 2000]

Step 2: P peaks selection

Step 3: Sampling step choice

→ Congregation of P peaks and sampled bands
~50 bands

Step 4: Backward elimination loop

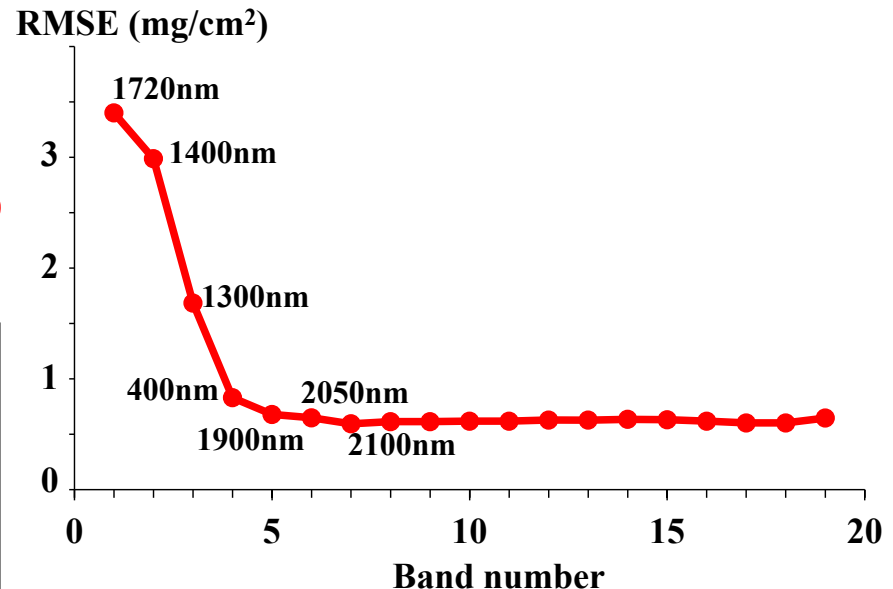
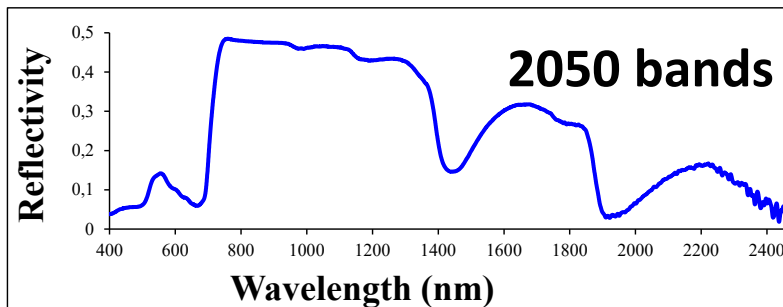

Band selection algorithm

Step 1: Band weight computation [Yacoub et Bennani, IJNS, 2000]

Step 2: P peaks selection

Step 3: Sampling step choice

➔ Congregation of P peaks and sampled bands
~50 bands

Step 4: Backward elimination loop

Step 5: Final band number choice

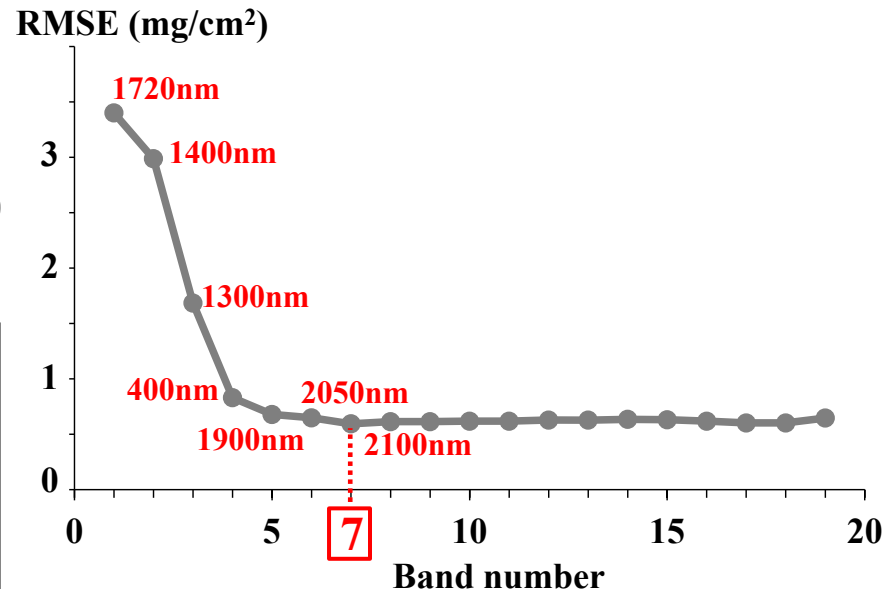
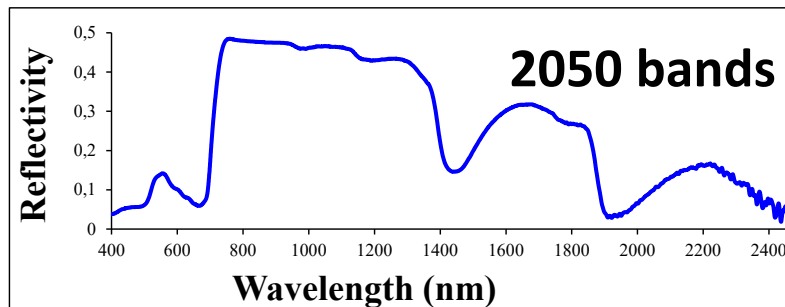

Band selection algorithm testing

■ Testing protocol:

- 20 random drawings in training, validation and test subsets (50%, 25%, 25%)
- **Band selection** using **uniquely** the **training and validation subsets** (and not the test subset)
- 20 different ultimate band subsets (1 per drawing)
- **Result : Mean RMSE over the 20 drawings**

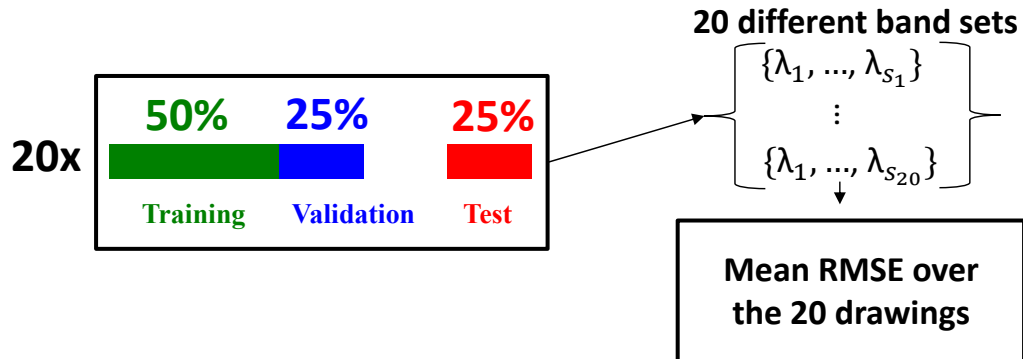

Band selection algorithm testing

■ Testing protocol:

- 20 random drawings in training, validation and test subsets (50%, 25%, 25%)
- **Band selection** using **uniquely** the **training and validation subsets** (and not the test subset)
- 20 different ultimate band subsets (1 per drawing)
- **Result : Mean RMSE over the 20 drawings**

■ A posteriori single band set finding

- **A posteriori unique band set determination** (band frequency-based forward selection loop)
- **A posteriori mean RMSE computation over the 20 drawings** (obtained with the unique band set)

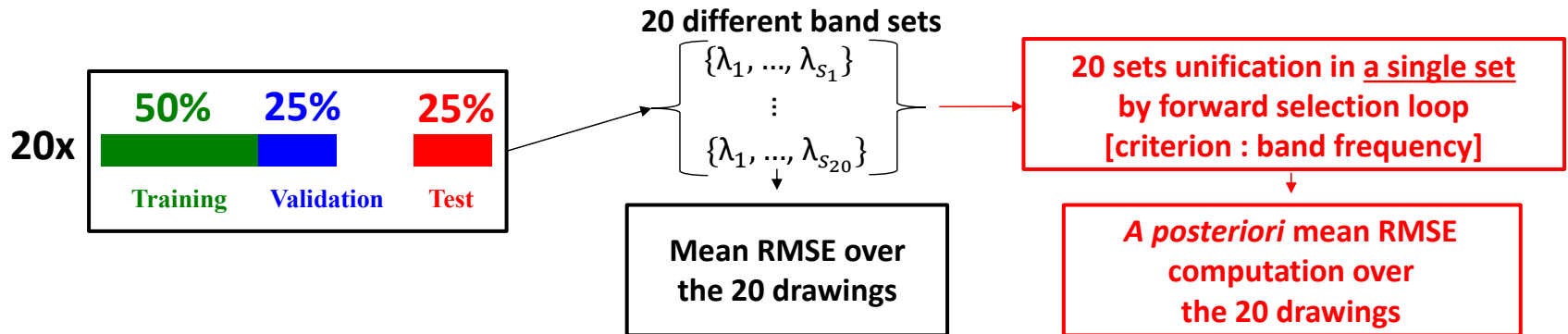

Results: Prediction Accuracy

Best vegetation index

$$ND = \frac{R_{1368} - R_{1722}}{R_{1368} + R_{1722}}$$

and R_{2300}

Mean performances
over the 20 drawings

Number of bands: 3
Mean Calibration RMSE: 18.6%
Mean Test RMSE: 22%

Graphical comparison
for a specific drawing

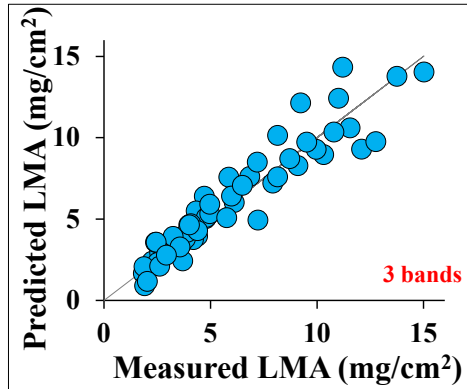

Results: Prediction Accuracy

Best vegetation index

$$ND = \frac{R_{1368} - R_{1722}}{R_{1368} + R_{1722}}$$

and R_{2300}

Number of bands: 3
Mean Calibration RMSE: 18.6%
Mean Test RMSE: 22%

Neural networks a priori band set

Number of bands: 3-9
Mean Calibration RMSE: 14.8%
Mean Test RMSE: 17.5%

Mean performances
over the 20 drawings

Graphical comparison
for a specific drawing

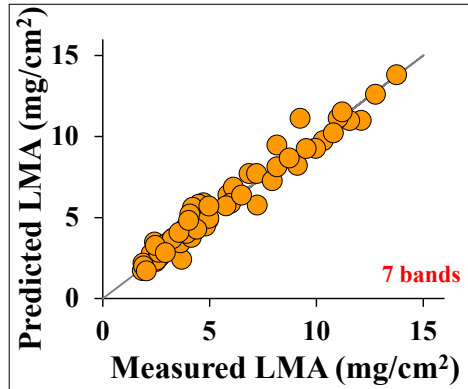
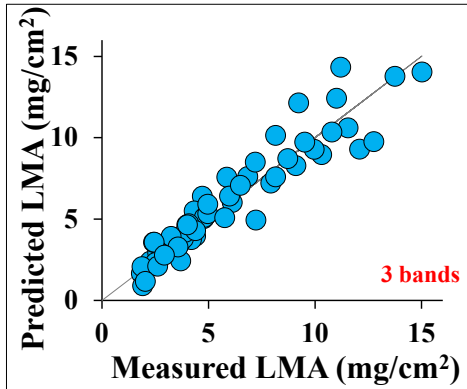

Results: Prediction Accuracy

Mean performances
over the 20 drawings

Best vegetation index

$$ND = \frac{R_{1368} - R_{1722}}{R_{1368} + R_{1722}}$$

and R_{2300}

Number of bands: 3
Mean Calibration RMSE: 18.6%
Mean Test RMSE: 22%

Graphical comparison
for a specific drawing

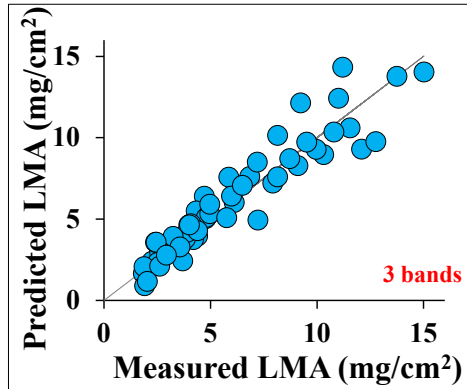

Neural networks a priori band set

Number of bands: 3-9
Mean Calibration RMSE: 14.8%
Mean Test RMSE: 17.5%

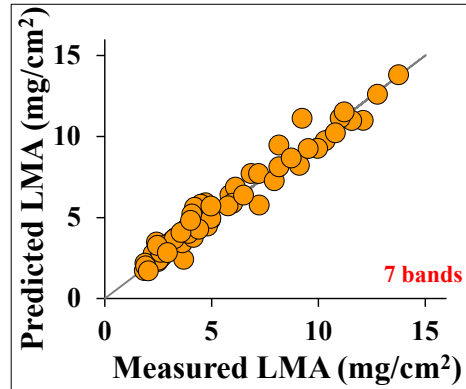

Neural networks a posteriori band set

Number of bands: 4
Mean Calibration RMSE: 15.2%
Mean Test RMSE: 18.1%

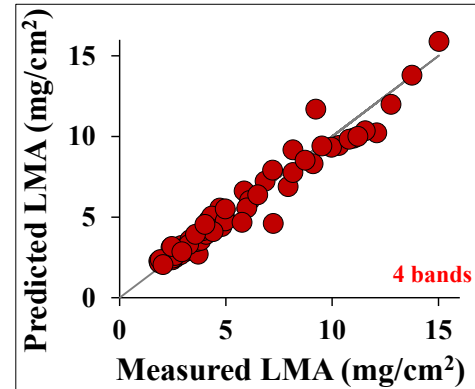

Results: Selected Band Analysis

Reflectivity

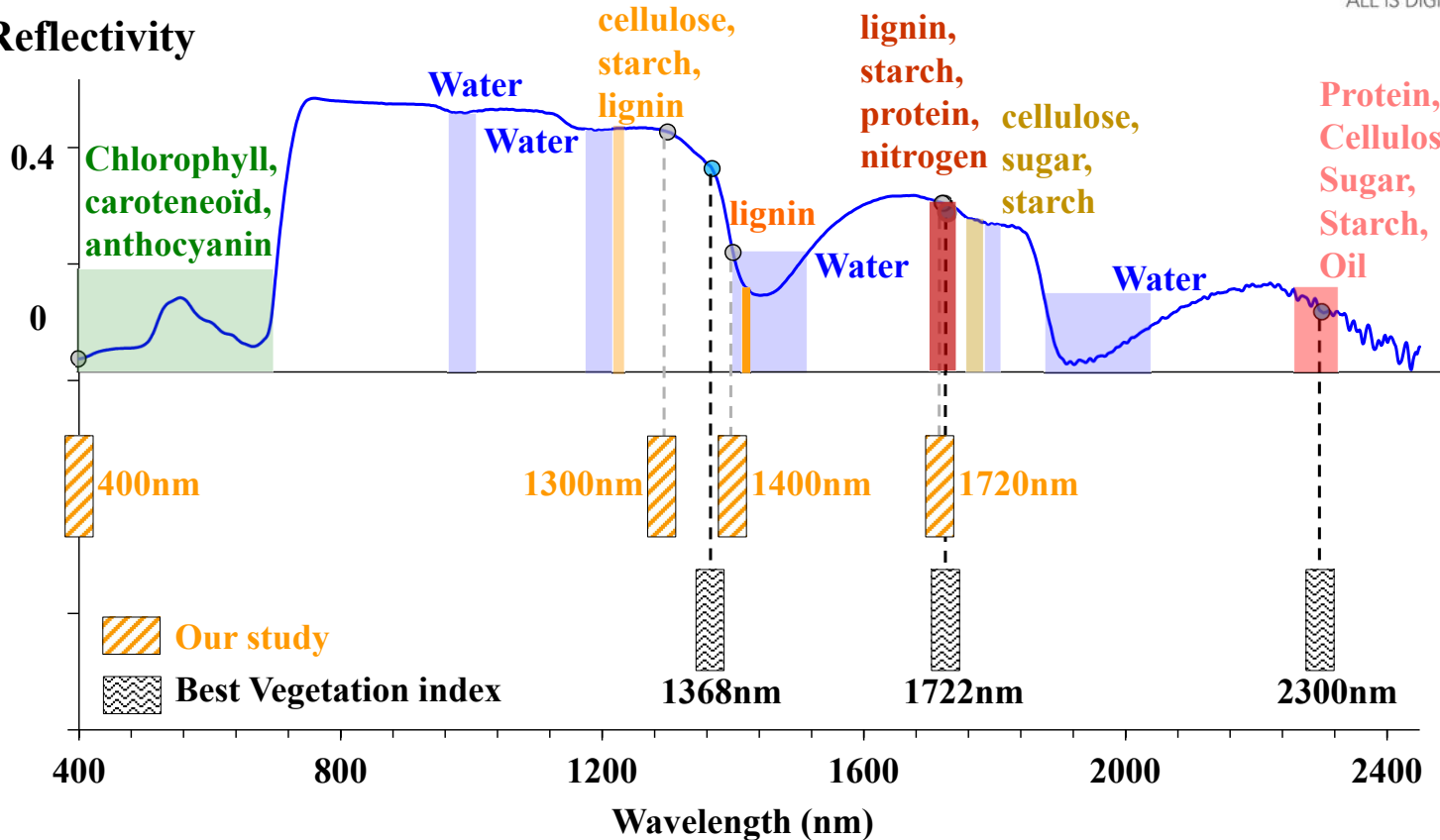

*Depiction of, only :
 - the main water peaks
 - The leaf constituent absorption peaks adjacent to the selected bands
 **Band extracted from [S. Jacquemoud and S. Ustin, *Leaf Optical Properties*, Cambridge University Press, Cambridge, 2019].

▪ Conclusions

Tested on the publicly available Angers database, the neural network band selection scheme:

- allows to reduce the relative RMSE of LMA prediction by 4.5 points as compared to vegetation indices
- while requiring a low number of bands (3 to 9)
- and leads to the a posteriori selection of 4 bands for LMA prediction [400nm, 1300nm, 1400nm, 1720nm]

▪ Prospects

- Further improvement of LMA prediction accuracy (via the creation of a new experimental database)
- Improvement of the prediction accuracy of other leaf parameters (Chlorophyll, Carotenoid, Anthocyanin, ...)
- Analytical formulae proposal for replacing neural networks
- Application to the detection of Tomato Plant Water Stress

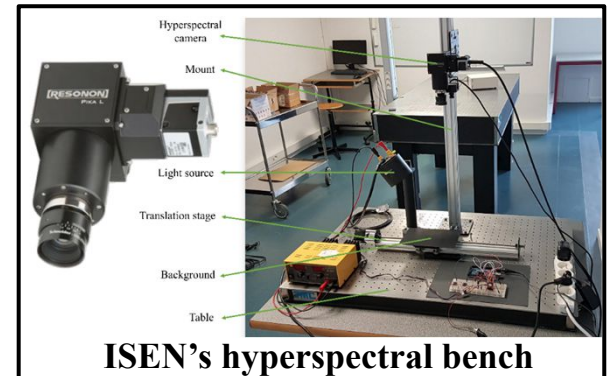

Thank you for your attention !

