



HAL
open science

Challenges and Opportunities in Geometric Modelling of Complex Bio-Inspired 3D Objects Designed for Additive Manufacturing

Nikita Letov, Pavan Velivela, Siyuan Sun, Yaoyao Zhao

► **To cite this version:**

Nikita Letov, Pavan Velivela, Siyuan Sun, Yaoyao Zhao. Challenges and Opportunities in Geometric Modelling of Complex Bio-Inspired 3D Objects Designed for Additive Manufacturing. *Journal of Mechanical Design*, 2021, 10.1115/1.4051720 . hal-03628796

HAL Id: hal-03628796

<https://hal.science/hal-03628796v1>

Submitted on 2 Apr 2022

HAL is a multi-disciplinary open access archive for the deposit and dissemination of scientific research documents, whether they are published or not. The documents may come from teaching and research institutions in France or abroad, or from public or private research centers.

L'archive ouverte pluridisciplinaire **HAL**, est destinée au dépôt et à la diffusion de documents scientifiques de niveau recherche, publiés ou non, émanant des établissements d'enseignement et de recherche français ou étrangers, des laboratoires publics ou privés.

Challenges and Opportunities in Geometric Modelling of Complex Bio-Inspired 3D Objects Designed for Additive Manufacturing

Nikita Letov

Department of Mechanical Engineering
McGill University
Montreal, Quebec, Canada H3A 0G4
Email: nikita.letov@mail.mcgill.ca

Pavan Tejaswi Velivela

Department of Mechanical Engineering
McGill University
Montreal, Quebec, Canada H3A 0G4
Email: pavan.velivela@mail.mcgill.ca

Siyuan Sun

Department of Mechanical Engineering, McGill University
Montreal, Quebec, Canada H3A 0G4
Email: siyuan.sun@mail.mcgill.ca

Yaoyao Fiona Zhao[†]

Department of Mechanical Engineering, McGill University
Montreal, Quebec, Canada H3A 0G4
Email: yaoyao.zhao@mcgill.ca

ABSTRACT

Ever since its introduction over five decades ago, geometric solid modelling has been crucial for engineering design purposes and is used in engineering software packages such as computer-aided design (CAD), computer-aided manufacturing (CAM), computer-aided engineering (CAE), etc. Solid models produced by CAD software have been used to transfer geometric information from designers to manufacturers. Since the emergence of additive manufacturing (AM), a CAD file can also be directly uploaded to a three-dimensional (3D) printer and used for production. AM techniques allow manufacturing of complex geometric objects such as bio-inspired structures and lattice structures. These structures are shapes inspired by nature and periodical geometric shapes consisting of struts interconnecting in nodes. Both structures have unique properties such as significantly reduced weight. However, geometric modelling of such structures has significant challenges due to the inability of current techniques to handle their geometric complexity. This calls for a novel modelling method that would allow engineers to design complex geometric objects. This survey paper reviews geometric modelling methods of complex structures to support bio-inspired design created for AM which includes discussing reasoning behind bio-inspired design, limitations of current modelling approaches applied to bio-inspired structures, challenges encountered with geometric modelling and opportunities that these challenges reveal. Based on the review, a need for a novel geometric modelling method for bio-inspired geometries produced by AM is identified. A framework for such bio-inspired geometric modelling method is proposed as a part of this work.

† Corresponding author

1 Introduction

Ever since the early days of humankind, nature has been an immense source of inspiration when it comes to designing and inventing [1]. For example, more than 2000 years ago people in Asia has noticed that some trees, such as *picea abies* (commonly known as European spruce) illustrated in Fig. 1a, have their branches shaped in a way that raindrops slide along them fast and rainfall water does not hold on them for long [2]. As there was need in preventing roof leakage, it is believed that this idea was adapted into the roof building process and can be traced up to pagoda roofs illustrated in Fig. 1b, which are common in China, Korea, Japan and other regions of Asia [3, 4]. The intuition of the ancient people led them to the right solution, as this shape appeared to be a so-called brachistochrone curve – an optimal curve of fastest descent and thus does not let water to stay on roofs for long [5]. Fig. 1c shows a plot of a brachistochrone curve and the specific time required to travel along it, as well as plots of a circular arc, a parabola, and a straight line for comparison. The history of design is full of other examples of bio-inspiration.

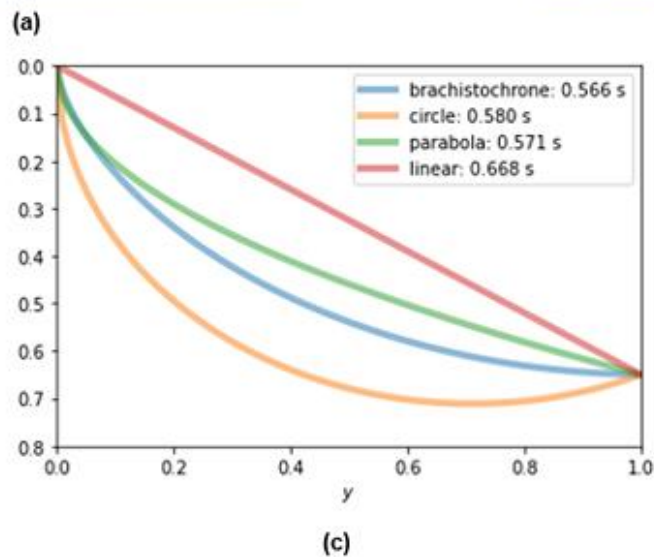

Fig. 1. (a) Branches of a conifer tree, (b) the roof of the Kiyomizu-dera temple in Kyoto, Japan [6], (c) brachistochrone curve – an optimal curve of fastest descent – to prevent rainfall water from staying on them

Another example is the glass sponge with complex hierarchical structures, which inspire some modern architectures in the world, such as the Swiss Re Tower in London, UK and the Eiffel Tower in Paris, France shown in Fig. 2b [7]. The intricate skeleton of glass sponge is shown in Fig. 2a [7]. The structure is strong and flexible even though it is made of fragile glass. The reason is that the glass sponge has complex hierarchical and lightweight structures from nanometer to macroscopic length scales, and they have been evolving to overcome the brittleness of the glass material, which helps it achieve light weight combined with high strength [8].

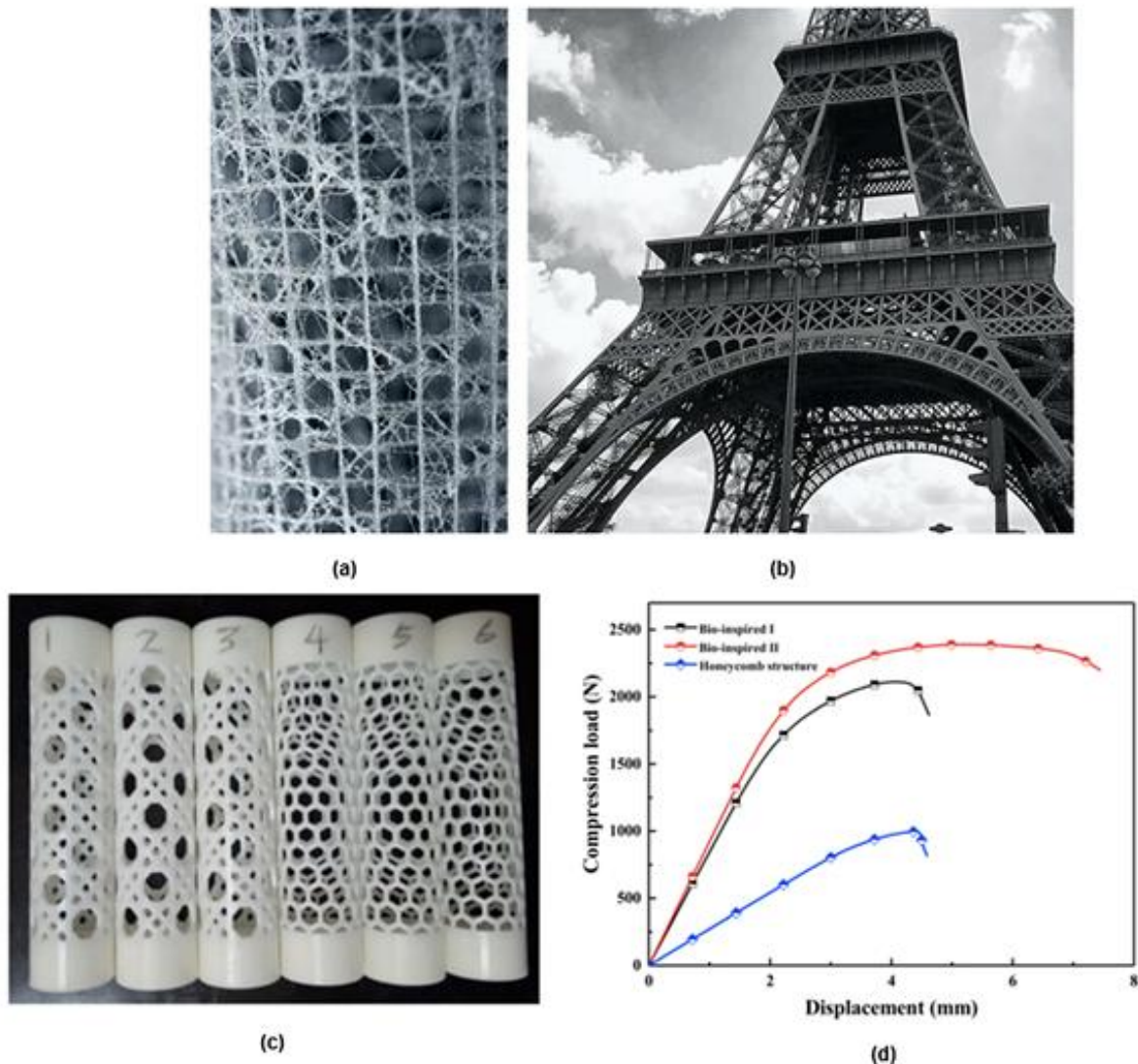

Fig. 2. (a) The intricate skeleton of glass sponge [7], (b) the Eiffel Tower in Paris [7], (c) bio-inspired structure and honeycomb structures, (d) the compression vs. displacement curves for three bio-inspired structures. Permission to reprint from IOP copyright [8].

This lightweight structure of the glass sponge also inspired engineering designs of tube-shaped and thin-walled structures such as the bio-inspired and honeycomb lightweight structures produced by AM as shown in Fig. 2c [8]. These two structures have been tested through finite-element modelling (FEM) analysis to compare the difference between their

material properties under a certain compression condition. As seen in the compression-displacement curve of different structures shown in Fig. 2d, the honeycomb structure was not able to provide good structural compression-bearing ability and low light-weight numbers compared to bio-inspired structure I and bio-inspired structure II structure, which indicates that the structure inspired from glass sponge performs better on the compression, bending and torsion capacity. Therefore, this lightweight structure inspired by glass sponge can potentially be widely used in the industry sectors requiring low weight and providing high reliability, such as aerospace and automotive industries.

Another similar example would be the aircraft structure inspired by the honeycomb structure. The honeycomb illustrated in Fig. 3a is comprised of hexagonal cellular structures which provides the most stable containment by using the least amount of material [9]. A cross-section of a rotor blade is presented in Fig. 3b, which is composed of various composite materials to produce a lightweight and strong rotor blade. The rotor blade incorporates the honeycomb structure since the rotor blade should be strong enough to provide the lifting force for the helicopter along with the adjustments of the angles of its blades while being as light as possible [9]. The bonding of the “green” (environmentally friendly) Nomex honeycomb core and metal skin also allows the designer to form desirable shapes into blades which increases the performance in terms of beam strength [10].

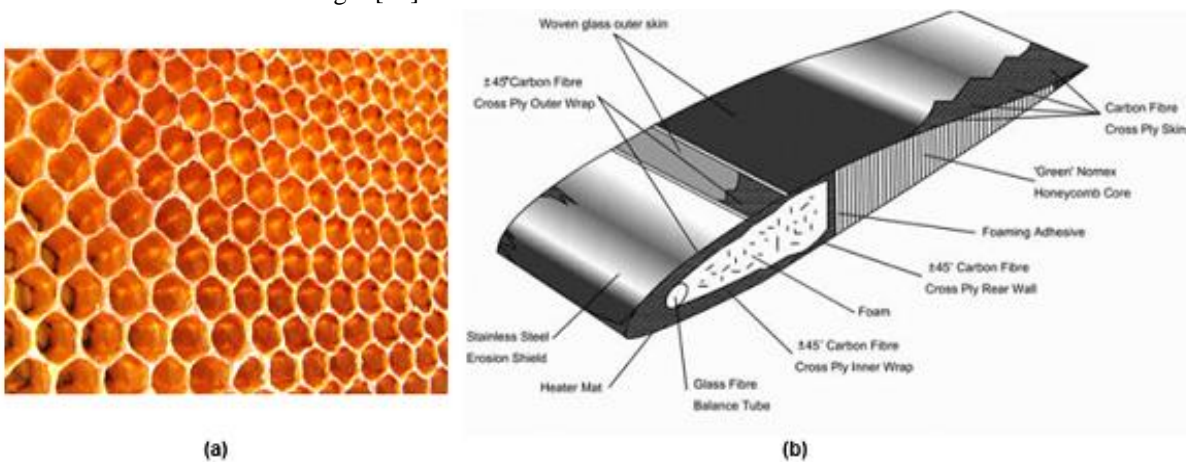

Fig. 3. (a) The honeycomb structure [11] and (b) the cross section view of composite rotor blade [12]

Solid modelling has been intensively used by engineers and designers ever since the introduction of the first computer-aided design (CAD) software packages. While conventional geometric modelling has proved itself useful for engineering design, it began to fail in meeting the demands of additive manufacturing (AM) techniques. In this work, AM is defined as “*the process of joining materials to make objects from 3D model data, usually layer upon layer, as opposed to subtractive manufacturing methodologies*” [13]. Existing CAD software packages and their geometric modeling kernels (GDKs) are not able to handle the significantly increased complexity bio-inspired design typically creates. They are also extremely challenged to model the complex structures that AM technology can easily fabricate such as heterogeneous lattice structures. In other words, the manufacturing capabilities develop faster than the geometric modelling capabilities required to support manufacturing. In this work, a geometric model is considered to be complex if (1) it is more difficult to model it with Boolean descriptive modelling rather than with parametric modelling, or (2) it is not possible to support 30 frames-per-second (FPS) frame rate performance on an average computer used in engineering. In this work, a machine is considered average if it can provide: 16 GB of random-access memory (RAM); 2 GB of disk space allocated on a solid-state drive (SSD); a 64-bit central processing unit (CPU) with the clock signal frequency of 3.3 GHz. These system requirements are identified according to the recommended system requirements for SolidWorks and Rhinoceros 3D software packages which are extensively used for 3D modelling [14, 15]. The threshold of 30 FPS is chosen as it is proven to be sufficient for convenient work and observations [16].

There are various applications of AM such as parts consolidations, weight reduction, functional customization, personalization and aesthetics [17, 18]. Numerous research domains are utilized in AM: computational optimization,

geometric modeling, behavioral simulation, material science, etc. [19, 20]. Even though these domains utilize different software tools, methodologies and approaches, they cannot be considered separately, e.g. computational optimization can be applied not only to weight reduction but to parts consolidation as well. The geometric modelling tool for AM needs to be able to support representation of these multi-domain simulations.

Geometric modeling in engineering is applied as early as at the conceptual design stage and the geometric model is used throughout the lifecycle of the product development. The conceptual stage of a product lifecycle is one of the most crucial ones. Costs committed to the initial – conceptual – design stage of the lifecycle are found to reach 70%, while only 8% are being spent during this stage as illustrated in Fig. 4 [21]. Thus, it is crucial to provide the initial stages of lifecycle with efficient geometric modelling tools.

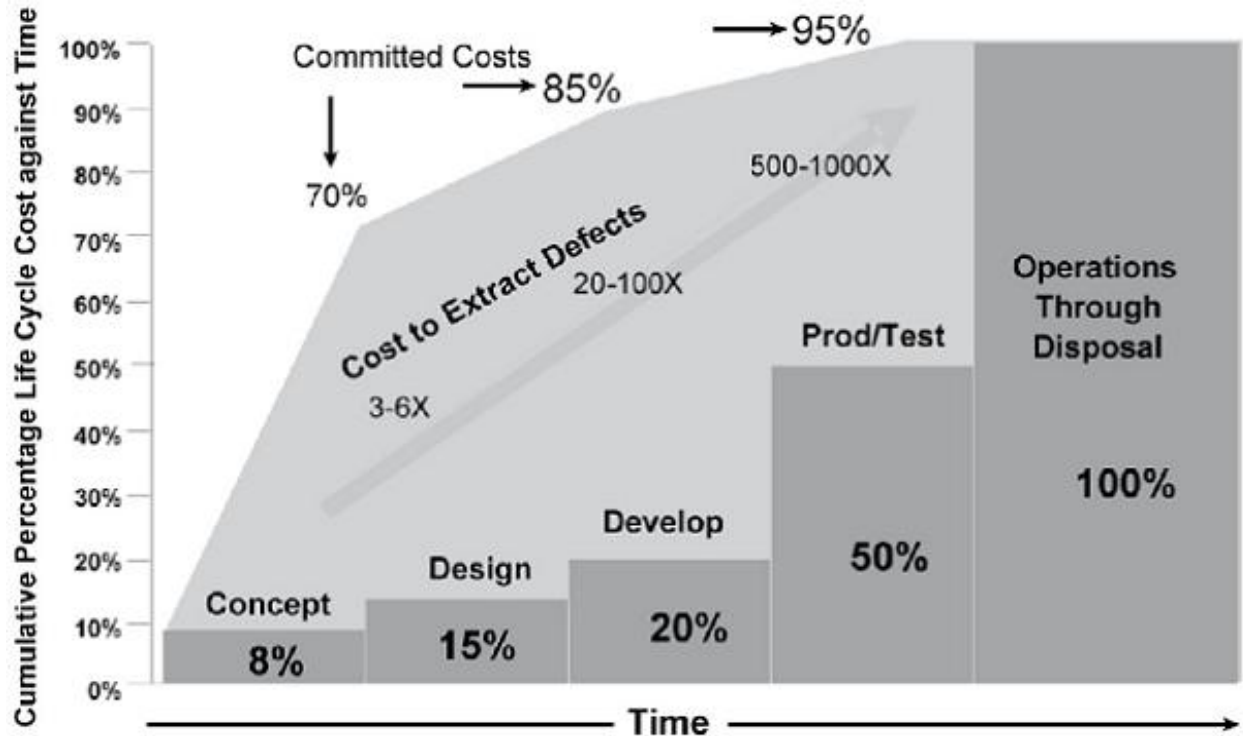

Fig. 4. Committed life cycle cost versus time. Permission to reprint from John Wiley and Sons copyright 2014 [21].

Current geometric modelling techniques tend to fail in supporting AM due to an increased design freedom provided by AM technology which can support high geometric complexity of manufactured parts. Since solid modelling is based on classical topology and geometry, the higher the geometric complexity, the harder it is to model it [22], especially when the geometry is bio-inspired and does not follow the common design rules [23]. This complexity cannot be provided by explicit modelling mainly due to enormous amount of Boolean operations required to design a single geometrically complex part [24] such as lattice and bio-inspired structures seen in Fig. 2c [25, 26]. It has been identified that there is no sufficient geometric modeling tool that would be able to represent complex heterogeneous lattice structures which forms a research gap that is yet to be filled [27].

The rest of the paper is organized as follows. In Section 2, concepts and current state of the geometric modelling and computer graphics are reviewed. Similarities of geometry discretization techniques with natural processes are also identified, the design and geometric modelling methods of bio-inspired geometric objects are covered. Section 3 separately focuses on geometric modelling of lattice structures as they are identified to be a subset of bio-inspired structures but with unique features that make them distinguishable from the rest of bio-inspired structures. In Section 4, the discussion of this review is made and an architecture of a potential tool for complex geometric object design is proposed and discussed. In Section 5, future prospects are identified, and conclusions are made.

2 Current status of geometric modelling of bio-inspired complex structures

Any engineering software that processes a 3D model, whether it is CAD, CAM, or CAE, has a geometric modelling kernel (GMK) at its core with other tools supporting it. GMK is responsible for building numerical models of required geometries via mathematical methods [28]. Geometric modelling of complex bio-inspired structures requires a thorough review as it has significant challenges identified, mostly related to defining the bounding shape and computational optimization of a GMK [29, 30]. The domains of mathematics behind every GMK include linear algebra, topology, mathematical logics, graph theory, and more [31, 32]. In other words, a GMK is mathematics turned into code so that the geometric information can be viewed on a screen. The algorithms utilizing these domains of mathematics work best when they are developed using programming techniques which can provide high-level functionality [33, 34]. A GMK is usually developed by a large team of software developers and mathematicians for several years and thus it is very challenging to develop a GMK by a small group of people [35].

A geometric object describes the form of the modeled object [36]. Geometric objects include curves, surfaces, bodies as well as topological objects that describe geometric properties that do not depend on quantitative features and describe permanently interconnected points in 3D space [37]. There are 2D and 3D geometric objects. 2D objects are used to work in definition areas of surface parameters, as well to work with planes of local 3D coordinate systems [31]. In this work, a 3D object is considered to be defined according to the functional representation (F-rep) methodology, i.e. by a real-valued function $F(X)$ where $X = (x, y, z) \in \mathbb{R}^3$ is the design space, such that $F(X) \leq 0$ is the object itself with $F(X) = 0$ being the object's surface, and $F(X) > 0$ is the rest of the design space [38]. To visualize these objects, most of the existing CAD software packages use GMKs for handling geometric information and making it available for user to see, which work together with parametric modelling kernels (PMKs) that support Boolean operations, constraints, etc. [31].

Topologically, the surface of a geometrically complicated part such as a lattice structure is a closed oriented 2-manifold M_g^2 of a significantly large non-zero genus ($g \gg 0$). In topology, a closed 2-manifold is a connected surface that exists in three dimensions. They are oriented if there is no path from one side of a surface to another, as seen in Fig. 5. In this work, only orientable 2-manifolds are taken into the account as only a solid body bounded by an orientable 2-manifold without intersections is manufacturable. A single simple unit grid has genus 5, meaning that it has many curvatures and detail on their micro-scale [39].

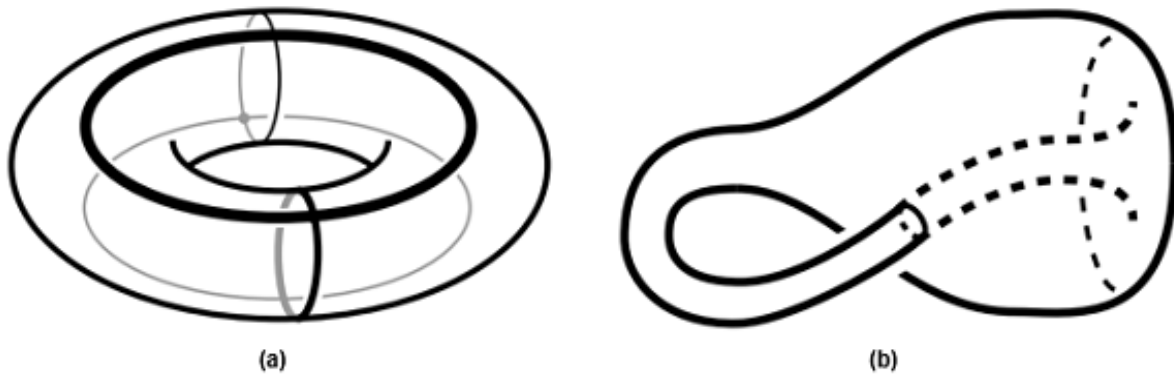

Fig. 5. Two closed 2-manifolds: (a) An oriented 2-manifold of genus 1 (torus) $T = M_1^2$ and (b) a non-oriented 2-manifold of genus 2 (Klein's bottle) N_2^2 [40]

Polygonal meshes begin to fail when complex geometric objects are modelled with them such as bio-inspired structures and heterogeneous lattice structures. One of the most popular non-proprietary CAD file formats – STL – utilizes polygonal representation [41]. In polygon surface mesh, number of finite elements rises exponentially with model

complexity and severely impacts modelling of complex shapes by making it way too computationally expensive as seen in Fig. 6 [42].

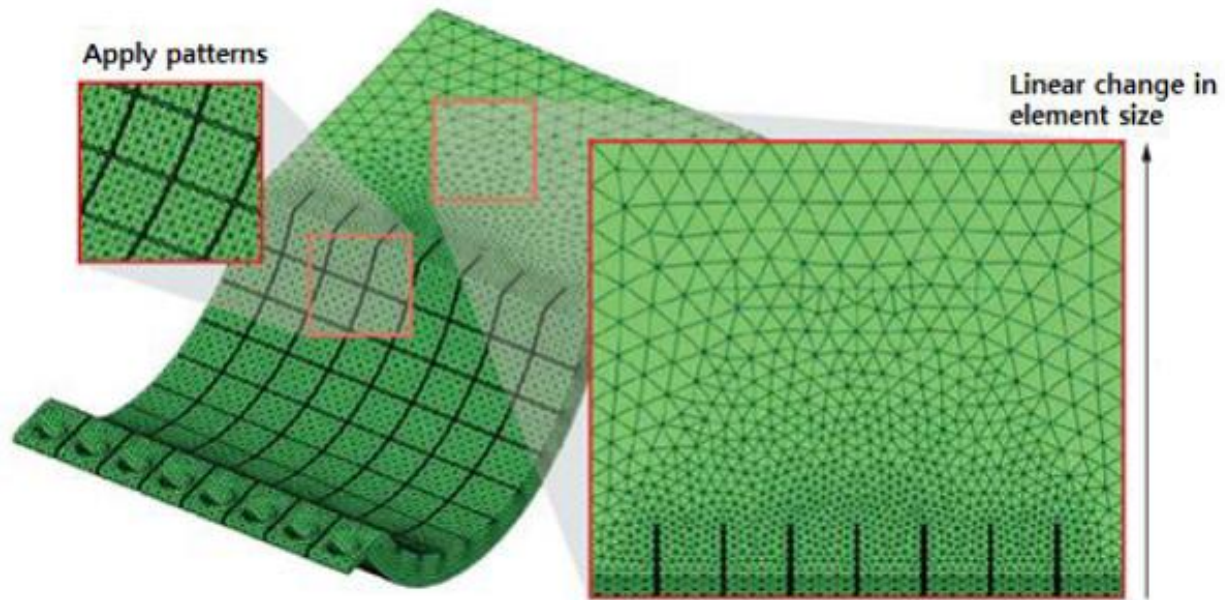

Fig. 6. Model complexity affecting computation expense of rendering a surface mesh [43]

Note that mindlessly increasing the number of nodes stops showing any improvement at some point and that critical non-plane areas normally require smaller element size [43]. Moreover, smaller finite elements not only increase calculation time but also introduce errors in geometry representation as seen in Fig. 7. This calls for approaches different from the ones used in most CAD software packages.

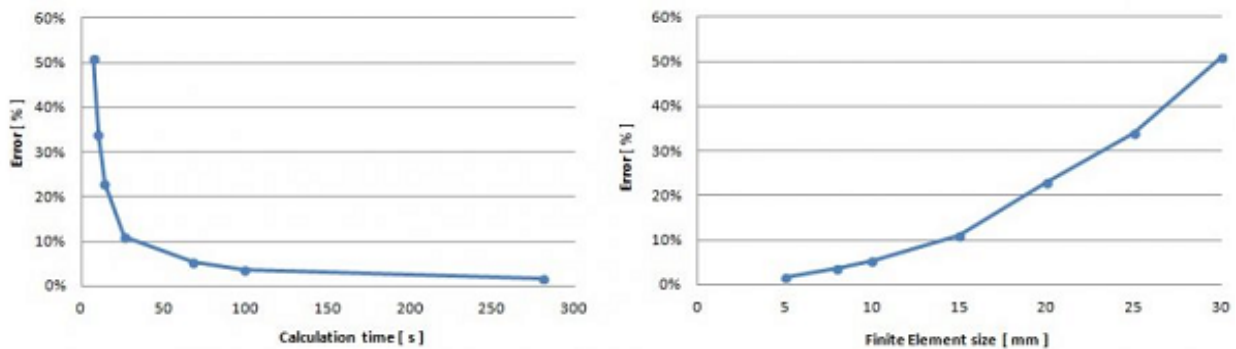

Fig. 7. Dependency of errors of geometric mesh representation (a) on calculation time and (b) on finite element size [44]

The so-called influencing points of increased complexity of the mesh require mesh edges to be orthogonal to the surface boundary for increased performance and decreased error-proneness [45]. Note that in Fig. 6 the mesh becomes denser when nearing the influencing points, in this case located near the surface boundaries and at non-plane surfaces. This requires extra calculations made which slows the mesh generation and the modelling process corresponding to it. The interpolation based on radial basis functions (RBFs) attempts to improve the performance of this operations significantly [46]. However, this approach was initially designed for 2D mesh generation and still requires certain improvements to be widely used in 3D. For example, it has been found that RBF interpolation may fail in case it is applied to a closed oriented

surface such as for example a full cylindrical surface. The reason for that is the failure to detect what is the influencing points in case of a completely symmetrical and closed surface as every point is influential in this case. The possible solution for it lies in applying hybrid methods that introduce parallelization to the process, but even then it requires top tier CPU capabilities [47].

Mesh modelling assumes that a solid model is defined by tiny finite elements (often triangular) each of which can be defined by vertices, as well as the position and orientation of the element in the design space. For example, below is an example of a triangular finite element defined in an ASCII STL file by its normal vector and vertices:

```
facet normal 0.95105690250522623 0.30901580574003779 -0
  outer loop
    vertex 14.842915534973145 11.243449211120605 -5
    vertex 14.648882865905762 11.840622901916504 -5
    vertex 14.648882865905762 11.840622901916504 0
  endloop
endfacet
```

Boundary representation (B-rep) techniques have been evolving rapidly and incorporated into major GMKs such as Parasolid and Open CASCADE. B-rep allows modelling of solids made by revolution, extrusion, chamfering and other operations with solids common in modern CAD in addition to Boolean operations used prior to B-rep [48]. For example, a torus in B-rep can be defined as a circle ρ given by

$$\rho^2 - 2\rho R \cos(\theta) + R^2 = r^2, \quad (1)$$

where (ρ, θ) are the polar coordinates (polar coordinates are favorable in representation of circles and curves in B-rep due to decreased computation time [49]), r is the radius of the circle (and of the torus tube), and R is the distance between the origin and the center of the circle (and between the center of the torus and the center of its tube). This circle is then revolved around the z axis of the design space.

B-rep suffers from the same inability to model highly complicated geometries such as the ones in Fig. 2 for example. The reason for this is a lack parametrization and numerous operations needed to achieve modelling of even a simple homogeneous lattice. The overall performance of B-rep methods can be improved by, for example, hybrid B-rep methods [50] and optimizing boundary spline (B-spline) functions [51, 52]. However, this optimization is still limited by the number of operations and efforts needed to model geometrically complex structures since even if functions are getting simpler there are still way too many of them in complex structures. Moreover, the surface-to-volume ratios of the multi-scale and lattice structures can be thousands of times larger than the CAD models encountered in conventional design, which poses big issue for the modelling tools based on B-rep.

Non-uniform rational basis splines (NURBS) and their extension to surface modelling were introduced to mitigate difficulties associated with modelling of complex structures and are used widely in B-rep [53]. NURBS surfaces and their trimming allow interpolation of the desired shape by points with simplicity. IGES and STEP are popular CAD file formats utilizing NURBS. However, trimming a NURBS surface $S(u(t), v(t))$ with a trimming curve $C(t)$ is not always possible, as it is not always possible to retrieve the knot vectors $u(t)$ and $v(t)$ for every parameter t [54]. Moreover, attempting to define an enormous amount of completely different NURBS surfaces for geometrically complex shapes makes the design process too tedious for a designer.

While B-rep does not operate with meshes, the mesh representation is still used for representing and rendering 3D models on screen. For example, even when a circle is defined in the design space, it still looks like a polygon with a number of vertices enough to be seen as a circle. Therefore, a certain conversion from B-rep to mesh is required to allow rendering of the model. This process is straightforward and has been extensively discussed in the literature [55, 56]. Spline-based B-rep are precise enough for conventional engineering design. However, as AM started to allow a higher level of design freedom and more complicated shapes became manufacturable. There appears to be a trade-off between

having a higher quality of geometry and having a more complex geometry. Note that the inverse problem is not that straightforward and encounters issues often associated with this type of problems, which are mostly related to a necessity to develop a feature recognition algorithm [57, 58]. There are techniques that allow rendering of shapes with curvature explicitly, and the development of these techniques significantly contributed toward research on F-rep since these shapes often require an explicit function that controls its curves [59, 60].

The lack of an appropriate tool to model bio-inspired structures makes it challenging to design them as well since designers often have difficulties to design micro-structures that are mimicked from animals or plants. Designers often try to replicate the actual structure/surface feature to obtain the maximum desired functionality during the conceptual development phase when sketching out their ideas [61]. For example, protective surfaces and structures that are used to protect dental implants when they are subjected to chemical etching process to enhance osseointegration process are hard to design [62, 63]. Moreover, printing the desired surfaces with the desired material is often a challenge as well. Keeping these challenges in mind, designers often try to simplify the design by re-defining the concept and seek inspiration from other animals or organisms [64, 65]. For instance, consider a conceptual design of a gecko inspired surface sketched in Fig. 8 as an example of a design that is required to go through functional and geometrical changes to be able to be modelled and manufactured.

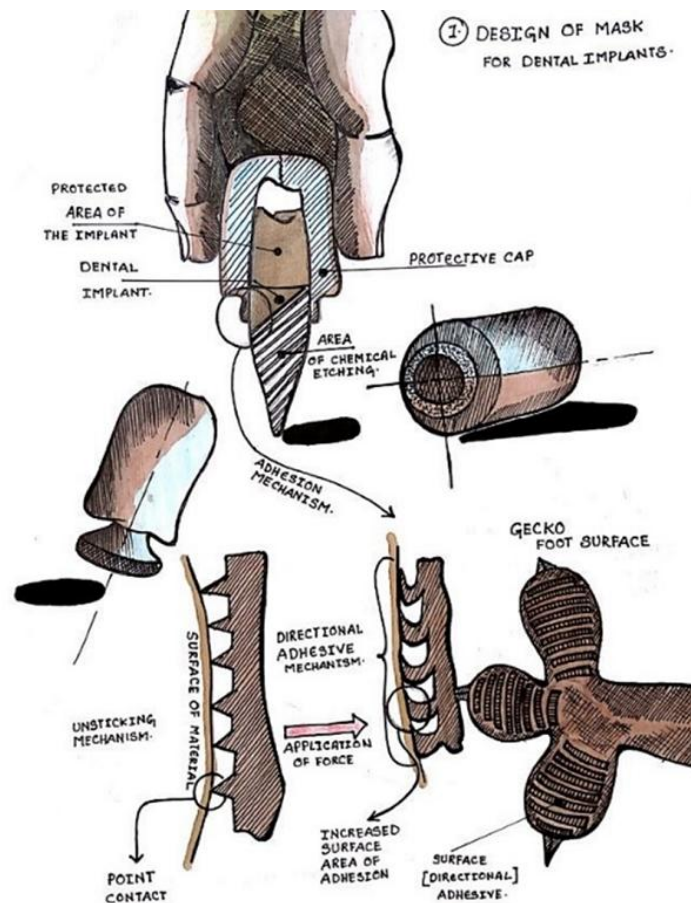

Fig. 8. The conceptual sketch of a gecko inspired surface that sticks to the implant surface [61]

The aim of this design is to provide a sticky surface and protect the upper part of implant when the dental implant is processed to chemical etching. Designing the setae (micro-hair) of the gecko's feet is a challenging task and to print them using a desired material is another challenge [66]. Due to these challenges geometric modeling and fabrication techniques, a transition to the design inspired by ant's claw serving the same function was made with two potential

conceptual designs sketched in Fig. 9a. Fig. 9b provides a more detailed version of the conceptual design and Fig. 10 provides the final CAD design which carries significantly less resemblance with the initial bio-inspired conceptual design. This is mainly due to the modelling and manufacturing issues arising from the geometric complexity of the initial conceptual design.

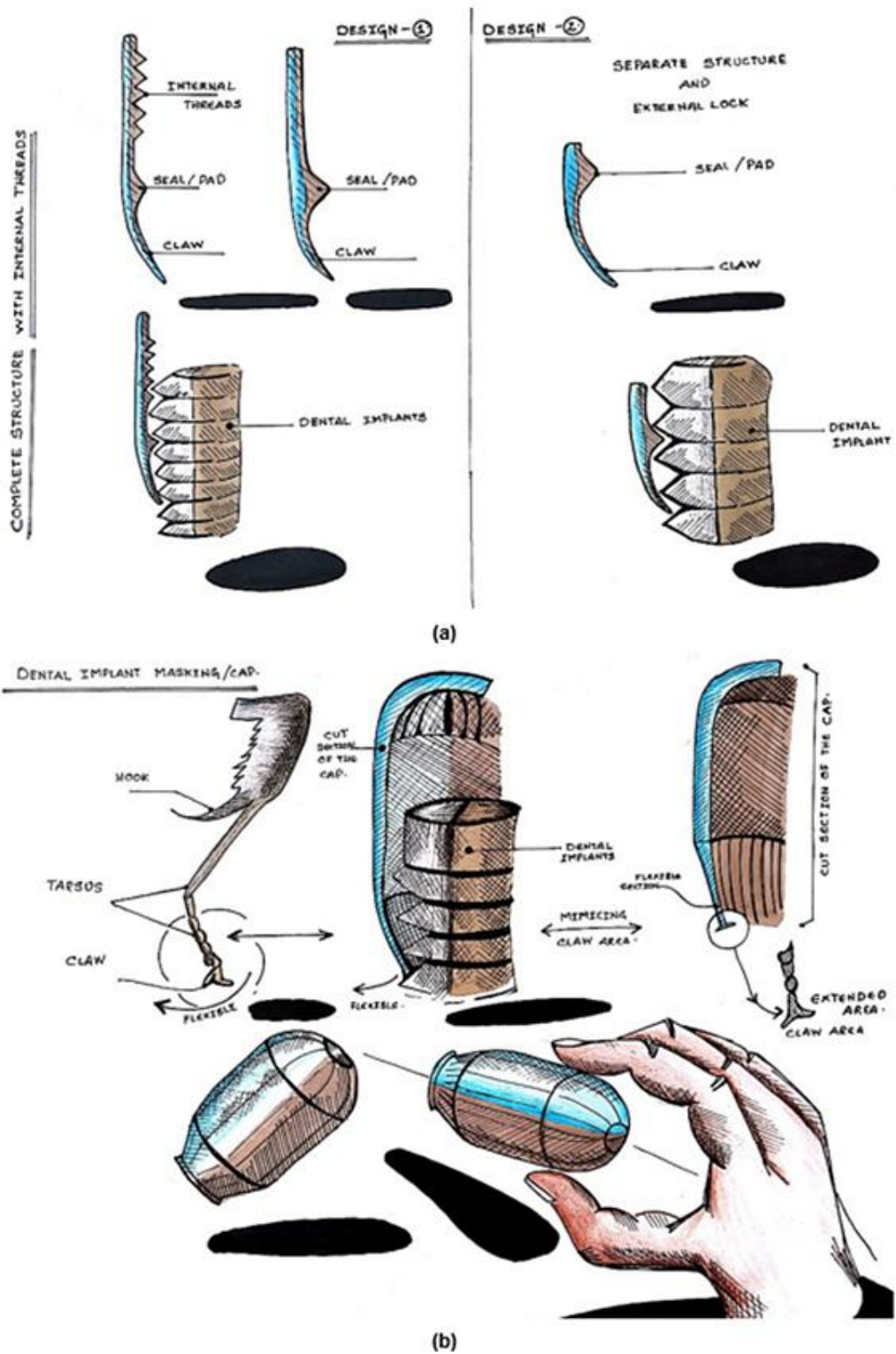

Fig. 9. (a) Two conceptual designs inspired by an insect claw (ant's claw) and (b) the conceptual design of the dental implant masking/cap [61]

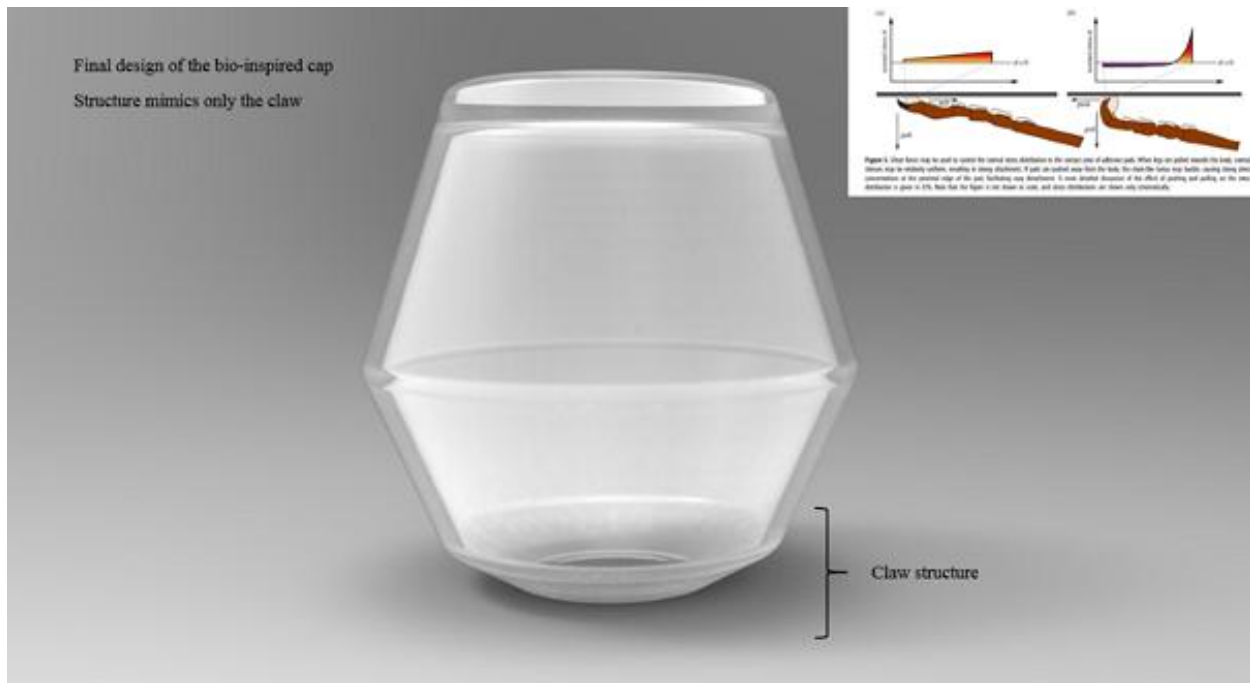

Fig. 10. Render of a protective cap inspired by an insect claw (ant's claw) [61]

This is only one example of a bio-inspired design affected by limitations of geometric modelling and manufacturing. There are many more including bio-inspired lattice structures resulted from topology optimization which often require top tier graphics processing capabilities and highly capable geometric modelling tool [67].

Normally, in bio-inspired design, the focus is made on a fixed set of functions, e.g. water resistance and/or increased stiffness [68]. However, organisms in nature often combine much more than just several functions. Moreover, the functions of living organisms are weighted differently. As an example, consider a camel in a desert: it does not focus that much on finding water (this task has not 0% weight for it, but it is not 100% either). Instead, it prioritizes more on storing the water in its hump and spending it carefully afterwards (with a weight much more than of just finding water) [69]. In the modern bio-inspired design the weights are essentially set to 0% or 100%, so in multi-functional structures the focus is made on some set functions and the other possible functions are neglected, even though several functions might actually solve the same problem: the camel solves his hydration problem as in the example above, but many other desert animals solve their hydration problem by actively searching for water at night (they get it from plants, mostly). Therefore, an investigation on how bio-inspired functions can be explicitly identified would be of great use, as they are required as a crucial input for function-based bio-inspired heterogeneous lattice structures modelling [70, 71].

To further explain the current status of geometric modeling methods for bio-inspired complex structures, the rest of Section 2 is organized as follows. In Subsection 2.1, discretization occurring in nature is covered and similarities with discretization in geometric modelling and computer graphics is identified. Subsection 2.2 reviews volumetric modelling techniques applied to complex geometric structures. Subsection 2.3 focuses on the multi-scale aspect of geometric modelling and challenges encountered in this aspect.

2.1 Discretization in nature

Discretization in geometric modelling and computer graphics is a topic of great interest as it allows control over the mesh size and density, thus directly controlling quality and complexity of the model. Similarly, discretization has a crucial role in the structure of living organisms as they are made of small living building blocks – cells. The algorithms of growth and development of living creatures form a prosperous research area of bio-inspired design. Moreover, some biological research involves geometric modelling of complex structures. For example, bio-inspired computational models

and algorithms for simulating of 3D multicellular tissue growth form a prospective research direction, which, however, lacks an appropriate geometric modeling tool [72].

Some recent research begins to dive into bio-inspiration when modelling or simulating complex bio-inspired structures. Dimas and Buehler [25] provided a novel modelling technique for bio-inspired composites which considers only a 2D cross-section of a composite for modelling and is mainly focused on performing simulations [25]. Fantini et al. developed a method to design bio-inspired structures based on Voronoi lattices [73].

When considering discretization in nature, the first thing to review is the structure of living organisms such humans. The evolution process made the simplest organisms on Earth converge to complicated and robust species. It resulted in developing optimal shapes and structures that are parts of living organisms developed in billions of years, e.g. scutoid cells which are 3D solids bounded by two polygons lying in parallel surfaces (not necessarily planar) and with vertices interconnected either by curves or by Y-shaped connection as seen in Fig. 11 [74]. Thus, there are yet any bio-inspired algorithm or a technique to adapt from nature into geometric modelling.

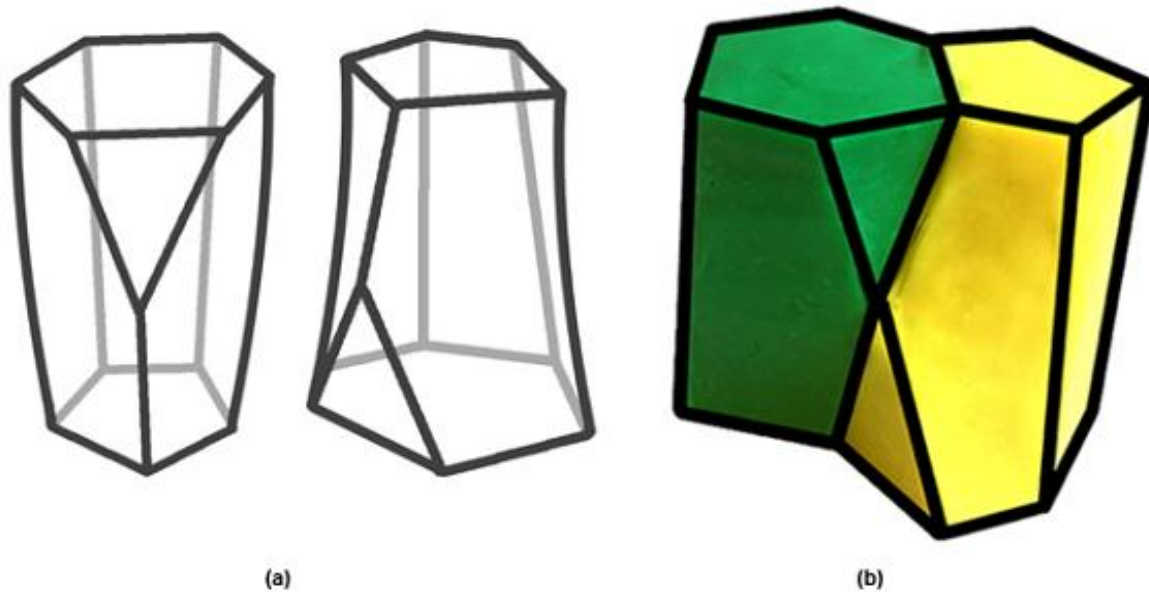

Fig. 11. Two scutoids (a) shown transparent separately and (b) shown opaque and transitioning one into another. Permission to reprint from Springer Nature copyright 2018 [74].

Surface mesh modelling resembles discretization similar to the way human skin consists of skin cell but does not model the interior. Voxels normally discretize a design space into cubes, while cell geometry is not necessarily cubic [30]. Note that the possibility of using non-cubic voxels was investigated and tested with various voxel shapes such as BCC and FCC (BCC is similar to a truncated octahedron and FCC is similar to a rhombic dodecahedron) [75]. The results of applying non-cubic were not encouraging enough as non-cubic grids appear to be more sparse than cubic grids that provide the most information about the structure. Currently, the sparse voxel octree technique allows modelling with voxels of different sizes [76]. However, the cubic shape of voxels remains the same which does not allow the variety of shapes that is present in nature and cubic voxels introduce anisotropy which depends on the orientation of cubic grid [75].

Considering that the idea of bio-inspired structures comes from nature, it is important to be able to model the variety of shapes. Moreover, as will be covered in Subsections 2.2 and 2.3, both mesh modelling and voxel modelling have certain computational and accuracy-related disadvantages when applied to complex geometric objects. Thus, for bio-inspired geometric modeling, other bio-inspired geometry classes must be considered [77].

In nature, there are numerous shapes and sizes of cells that together emerge into a living body. These parameters are greatly defined by the cell division process, which in turn is defined by genetics and external conditions. Thus, it is required to consider the cell division process in more detail.

There are numerous rules that are followed in cell division. One of them is the long axis rule (LAR) that has been observed in nature and it defines the cleavage plane as the plane perpendicular to the longest axis passing through the center of mass of cell [78]. Considering that a geometric model is not assigned any material, the centroid could be taken instead of the center of mass.

However, there are cases when the LAR is not satisfied, which readily indicates that the LAR is not followed in nature all the time and that there are other algorithms that define the shape and position of cells. The other rule is the surface-to-volume ratio (SVR) minimization [79]. The smaller the SVR is – the less the cell is exposed to commonly unfriendly external environment [80]. The most optimal shape from this point of view is a sphere which is not always feasible due to external conditions such as neighbouring cells and other geometric constraints. However, in some cases the SVR tends to be maximized, e.g. trees having a larger leaf area receive more sunlight and carbon dioxide and are able to survive better [81].

This already suggests that if there is a bio-inspired geometry discretization technique exist, it cannot be a single algorithm but rather a combination of several algorithms with a tuned trade-off method. The way the trade-off between different cell division processes occurs in nature is still an open question in cellular biology [78]. Note that even though only two biological rules are presented in this review, in nature there are many more and they continue to be constantly discovered [82].

In one of the recent works, a method that takes the above mentioned two rules is described in depth in an approach using volumetric cells [39]. The flowchart in Fig. 12 illustrates the approach. In this algorithm,

$$C := \bigcup_{i=1}^n \left(V_i / \bigcup_{j=1}^m \partial V_i^j \right) \subset \mathbb{R}^3 \quad (2)$$

is the whole structure which is subdivided into numerous volumetric cells V_i^j in k steps until the maximum number of steps k_{\max} is reached. However, the implementation is demonstrated for 2D cases which is insufficient for supporting complex 3D geometries. Moreover, the trade-off algorithm between the two rules has not been developed and the choice of the method for each iteration is performed manually.

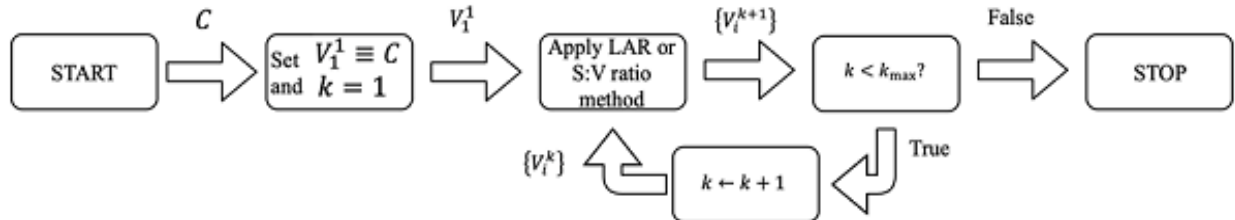

Fig. 12. The bio-inspired geometric modelling algorithm based on the long axis rule and the surface-to-volume ratio minimization rule observed in nature [39]

Indeed, taking a close-up look at epidermis – the upper layer of human skin shown in Fig. 13 – reveals that it looks similar to Voronoi tessellation and is extensively used for modelling human skin, as well as for FEM mesh modelling seen in Fig. 6 [83, 84].



Fig. 13. A close-up on human skin

Altair SimSolid uses specific algorithms for recognizing features within a model, e.g. planes, bolts, screws, etc., thus describing the model with a complex but single mathematical equation, which allows avoiding meshing for simulations [85]. In case of, for example, detecting a bolt, it works by detecting a hexagonal head on top of a cylinder and thus assuming that this solid body is a bolt. However, this feature recognition of Altair SimSolid appears to be pre-defined, and it fails to detect screw that do not have hexagonal heads, for example. Some feature recognition algorithms, including the bio-inspired ones, might find application in discretization in geometric modelling [86]. Moreover, a single mathematical equation might as well be non-computable due to its complexity.

2.2 Volumetric modelling

Challenges with surface mesh modelling force developing of tools utilizing voxel modeling for designing complex geometric structures [87]. Voxel modelling has been used for eliminating high-frequency details of the object ever since the introduction of voxels [88, 89] which is essential for modelling complex structures such as bio-inspired ones. Moreover, voxels have an advantage in terms of downsampling and acquisition of real-world data [76]. Moreover, there is no need in voxels smaller than 3D printer resolution as they would not be manufacturable [90]. Voxelized models support the same Boolean operations as the mesh models [87]. A significant advantage of voxel modelling for AM lies in straightforward machine learning applications, such as prediction of model printability [91].

In voxel modelling, voxels normally have a cubic shape [75] with some non-cubic approximations such as the ones produced by the marching cubes algorithm [92, 93]. Having the same element tessellated in the design space results in inaccurate representation of curvatures in case of having not enough voxel density, while having a significantly high voxel density results in high computational expenses. Applying the level-set method (LSM) allows considering a voxelized 3D design space as a set of 2D layers which improves the computational complexity from $O(n^3)$ to still rather complicated $O(n^2)$ [94].

Applying voxelization as it is without any additional optimization is still computationally expensive [95]. One of the most popular voxel-based simplification methods involves using sparse voxel octrees which are based on generating multi-scale voxels which could be visible or invisible depending on the resolution, size of the screen, and point of view [76]. This approach applied to large voxel models can result in up to 6 times increased efficiency [96].

Another volumetric modelling approach is the finite volume method (FVM) which generates volumetric mesh similar to surface mesh but with the whole solid body discretized rather than just its surface, i.e. the body is subdivided into polyhedrons, not polygons [97]. However, this approach has disadvantages similar to surface mesh: computation of curvatures is non-trivial due to their geometric complexity and the computational expenses rise exponentially with complexity.

Note that unit elements in every existing geometry discretization technique are always convex, whether they be finite elements or voxels. Convex unit elements require less computation, but it is required to have more unit elements to

model strongly non-convex shapes such as bio-inspired lattice structures. This implies the need in a proper meshing algorithm that takes convexity and curvature into the account and affects quality of meshed models, especially the ones requiring multi-scale modelling [98]. Thus, there is critical need to identify whether non-convex unit elements such as the one sketched in Fig. 14 could be used for geometric modelling of non-convex geometries. Note that combining two finite elements colored in red into one would result in a computationally less efficient finite element but would also reduce the total number of finite elements, introducing a trade-off between these two parameters. It should be investigated in more detail whether such a trade-off of computational efficiency of rendering separate unit elements for a lesser amount of unit elements is beneficial for the whole model rendering efficiency.

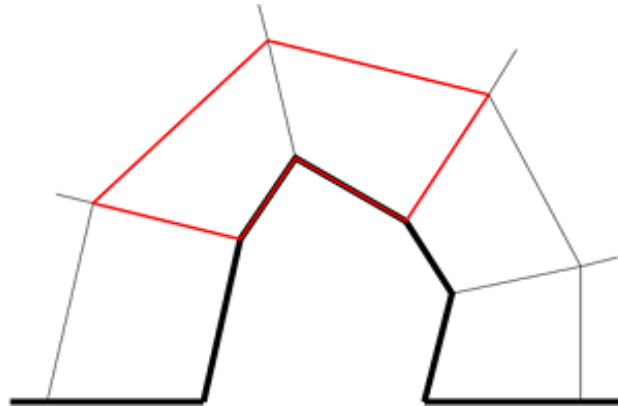

Fig. 14. A mesh of non-convex geometry

Volumetric representation (V-rep) modelling is another volumetric modelling technique that has been introduced recently and that has brought attention from the engineering community [99]. It utilizes elliptic partial differential equations (PDEs) and modifies the design space to have a variety of unit volumes that handles extreme geometric complexity. The approach is superior to B-rep modelling in terms of geometric complexity handling [100] and can be adapted for simulation purposes easier [101]. However, it suffers from a similar issue with B-rep: while in B-rep two surfaces collide by an edge or a group of edges, in V-rep two volumes collide by a surface or a group of surfaces. Since surfaces are in general more computationally costly than edges [102]. This can dramatically increase the computational expenses in cases with a large amount of unit volumes. There is evidence that the hybrid B-rep approach discussed previously in Section 2 can be applied to V-rep to increase its performance as well [50]. The torus that was used as an example in the previous section can be represented in V-rep as a union of 5 solids of revolution as seen in Fig. 15. Note that the ‘core’ of the torus (colored in red) is required to be a separate solid to avoid convergence of other 4 solids to zero.

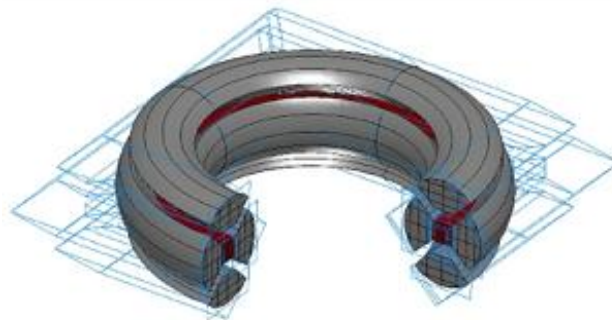

Fig. 15. A torus is constructed using five solids of revolution in V-rep modelling [100]

Volumetric modelling with iso-geometric finite elements utilizes cubic finite elements that are transformed to fit the desired model better by, for example, moving vertices of the default cube to new positions as illustrated in Fig. 16a. The resulting model consists of numerous iso-geometric finite elements as shown in Fig. 16b. However, this method

inherits drawbacks of both polygonal-based modelling (e.g. having irregularities at regions with high curvature) and voxel modelling (even though the variety of shapes is larger than having only one type of voxel, the finite elements are still limited to having 6 faces).

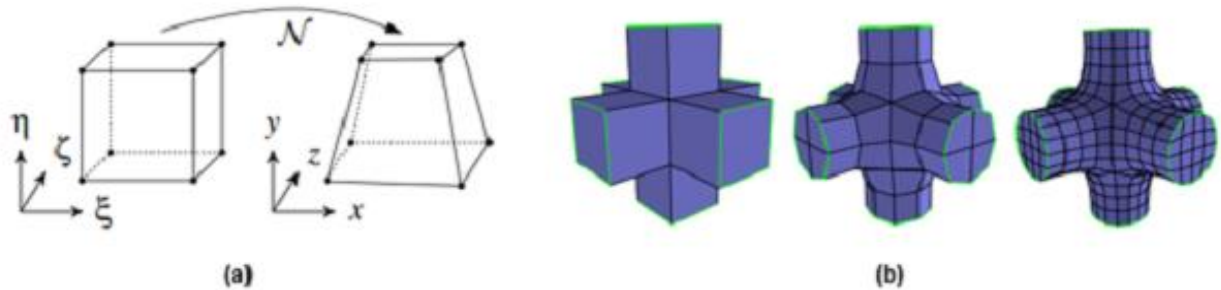

Fig. 16. (a) A transformation \mathcal{N} of a cubic finite element to a new shape and (b) a geometric modelling of a structure with different stages of refinement with iso-geometric finite elements. Permission to reprint from John Wiley and Sons copyright 2010 [103].

The described drawbacks of voxel modelling suggest modifying volumetric modelling techniques to better fit the rising demand for a geometric modelling approach that could support more complicated geometry. Using non-cuboid voxels which often find their use in computer graphics rather than in geometric CAD modelling improves the performance but introduces significant distortion to the model they are applied to. However, there is evidence that using a variety of unit volumes in a single model can dramatically improve both performance and quality of the model. The IRIT modelling environment does this by allowing modelling of so-called VModels with non-conventional unit volumes which allows storing 3D data in much smaller sized IRT files [104].

Similar results have been shown in the work that introduces bio-inspired 2D cells which can potentially be brought to 3D as volumetric cells [39]. This bio-inspiration is based on natural cell division process – every living being is made of living cells and there is normally a huge variety of shapes of different cells. Since nature has been optimizing these shapes through billions of years of evolution, this suggests that there could be an optimal bio-inspired geometric modelling approach. The method is described in more details in Subsection 2.1 as the algorithmic base for it is based on nature and is 2D at this stage.

2.3 Multi-scale modelling

Currently there are many challenges present in the area of geometric modeling of complex structures [105, 106]. One of the most crucial challenges when it comes to modelling of bio-inspired structures is multi-scale modeling support, which enables the delivery of sufficient and accurate visual information from meso- and macro-scales [107].

In geometric modelling, the concept of level of detail (LoD) is applied widely to reduce computational cost, which essentially reduces model's complexity by decreasing the amount of details and vice-versa. Fig. 17 shows an example of how model complexity changes when the number of polygons in a surface mesh model of the Stanford bunny decreases. Note that the higher of the LoD – the more details are rendered.

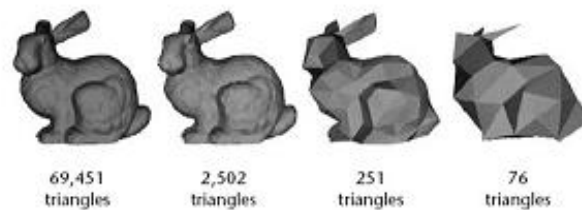

Fig. 17. Reducing the complexity of a 3D model by decreasing its level of detail that directly corresponds to the number of polygons required to render the model. Permission to reprint from Elsevier copyright 2002 [108].

Normally, LoD is manually or automatically associated with CAD features as illustrated in Fig. 18 [109]. However, bio-inspired structures are normally designed using parametric modelling techniques and not explicit. This results in ambiguity in choosing what could be considered a feature corresponding to each particular LoD.

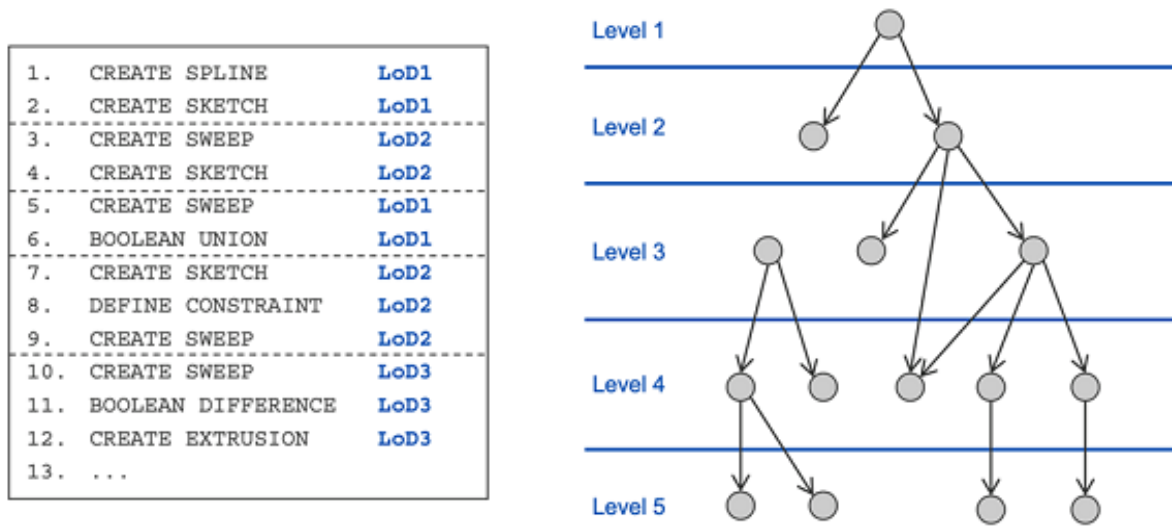

Fig. 18. Levels of detail associated with Boolean operations in CAD. Permission to reprint from John Wiley and Sons copyright 2014 [109].

Interestingly, there are other areas of research, different from bio-inspired structure modelling, that are forced to deal with LoD ambiguity. For example, in geoinformatics, it is required to consider a 3D scan of a large archaeological site such as the one of the Maya civilization from various LoDs, starting with a whole Maya city (LoD0) and ending with ornament details of a column in one of the buildings (LoD3) [110]. A multi-scale geometric modeling approach could also solve problems in medicine [72, 107], e.g. a need for a geometric modeling approach for modeling a human heart both as a whole and in details (as even small defects are crucial) is identified [111].

For voxel modelling, the depth of rendering (which is required for fully adaptive multi-scale voxel modeling [112]) is assumed to be given and the voxelization algorithm is not adaptive, which makes multi-scale modeling challenging with voxels.

Current voxel iteration methods are not adaptive due to difficulties in clustering of voxels [113, 114]. This forms a research gap by having a lack of an appropriate adaptive voxelization algorithm for geometric modeling, i.e. automatic changing of voxel size depending on the distance to the user according to LoD: current approaches are unable to represent crucial features of a part on a larger scale with voxels [115] and become sufficiently slow on a smaller scale [95]. Thus, it is not clear which features should be associated with LoDs, how to recognize and classify the features, and which voxel size is sufficient to represent a feature.

3 Review of geometric modelling methods for heterogeneous lattice structures

A lattice structure is defined as “an architecture formed by an array of spatial periodic unit cells with edges and faces” [116]. Lattice structures are considered as a subset of bio-inspired structures in this work, as the idea of lattice structures comes from nature initially: they take their inspiration from hexagonal bee honeycombs, spider webs, internal sponge-like bone structure, etc. Lattice structures have been challenging to manufacture due to their complexity until the introduction of AM [117]. They provide an optimal performance-to-weight ratio and other unique properties that do not emerge from conventionally manufactured parts, e.g. gradual elasticity of the structure, water absorption or resistance, etc. [118, 119, 120]. They can be classified into homogeneous and heterogeneous as sketched in Fig. 19. In homogeneous lattice, the thickness of struts or nodes inside of it stays the same over the entire structure, while these parameters vary in heterogeneous lattice [121]. Heterogeneous lattice structures appear often in the design of structures with optimized

geometry such as the ones produced with topology optimization [122]. Note that while having heterogeneous materials within the same structure is a popular topic of interest [123], this work focuses on geometric issues only and takes only geometrical heterogeneity into the account.



Fig. 19. (a) A heterogeneous and (b) a homogeneous lattice structures [121]

The concept of lattice structures is bio-inspired, but some lattice structures are bio-inspired in a way that they possess special shapes and properties of living organisms more vividly [124, 125, 126]. The majority of lattice structures in nature are heterogeneous as this enables to sustain more complex geometric shapes and a larger variety of them [127, 128]. Mostly bio-inspired lattice structures are utilized in very specific use-cases, e.g. when it is required to provide properties that are unique to certain biological species [129, 130, 131]. For instance, An and Fan [124] provide an example of a heterogeneous sponge-like lattice structure that makes a part ultra-lightweight while maintaining its strength and energy absorption, showing an example of a completely heterogeneous non-periodic lattice structure. Geometric modelling of homogeneous lattice structures has been extensively covered in literature [132, 133, 134], which is not the case for heterogeneous lattice modelling. With this in mind, this section specifically dedicated to discussing geometric modelling of *heterogeneous* lattice structures, covering their semi-periodic nature which introduces both challenges and opportunities. Such complex geometric objects like heterogeneous lattice structures have various parts that require different modelling techniques combined in the modelling tool as the geometry consists of features of different sizes and shapes, such as nodes and struts in lattice structures [135, 136]. The issues with modelling of heterogeneous lattice structures often result in substitution of their models with homogenized versions or with 2D cross-section analog of them, with both of which being incapable of providing accurate information about an heterogeneous object [137, 121].

Many of the issues and challenges arising in geometric modelling of lattice structures were analyzed in one of the previous works, including the application of LoD, as well as polygon mesh and voxelization algorithms [123]. This work, however, extends the previous review of geometric modelling of lattice structures, as the scope of this review lies also in identification of possible venues for the development of a tool for modelling of complex geometric structures, including heterogeneous lattice structures.

3.1 Challenges in geometric modelling of heterogeneous lattice structures

Using conventional CAD for designing lattice structures has its own flaws which have been extensively reviewed in literature [138, 123]. The main issue with designing heterogeneous lattice structures with descriptive CAD systems is inconvenience and difficulty in describing even a homogeneous lattice with just Boolean operations, i.e. it is not trivial to associate some lattice feature with a set of Boolean operations, similar to associating LoDs to CAD features covered in Section 3 [139]. Designing heterogeneous lattice structures is even more challenging.

Using non-standard modelling solutions has proven itself useful for generation of homogeneous lattice structures with parametric design tools such as the Intralattice plugin for Rhinoceros 3D, but they are still incapable of modelling heterogeneous lattice structures [140, 141]. Moreover, heterogeneous lattice generation and visualization can still be slow when performed on an average machine, as mentioned in Section 1, mostly because of the complexity handling issue of the polygon surface modelling. Fig. 20 illustrates several lattice topologies applied to the same design space using Intralattice. Note that these topologies are quasi-homogeneous: there is a pattern but in polar coordinates and not in Cartesian.

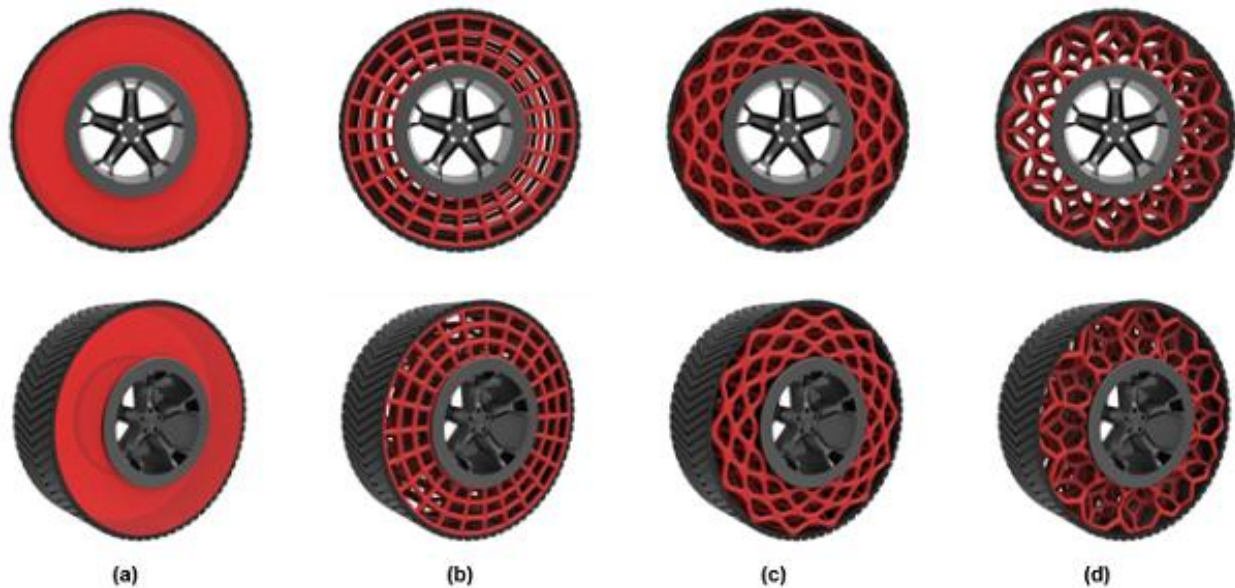

Fig. 20. Tire designs with different lattice topologies, which include (a) bare design space, (b) grid lattice, (c) X lattice, and (d) vintiles lattice [140]

A similar tool which also works as a plugin for Rhinoceros 3D is Crystallon distributed by the General Public Licence 3.0 (GPL-3.0) [142]. However, it has a limited library of lattice topology with no interface to define more topology in a simple way. Similar to Intralattice, heterogeneous lattice structures are not supported. There has been research on using both Intralattice and Crystallon for the same project with Intralattice used for topology generation and Crystallon used for nodes generation [143].

Rhinoceros 3D uses polygonal representation at the core of its GMK which is limited when rendering highly complex structures. The General Lattice Studio (GL Studio) plugin for Rhinoceros attempts to improve the performance of Rhinoceros 3D by bringing B-rep to a format readable by Rhinoceros GMK [144]. GL Studio allows modelling pseudo-periodical lattice structure which provides a certain degree of heterogeneity to the lattice it is applied to, but the general topology remains the same. This, however, is mostly a performance improvement tool which still suffers from issues related to B-rep that were described in Section 2.

Thus, similar to any other bio-inspired structure, heterogeneous lattice structures lack an appropriate modelling software for their modeling as they require an optimized mesh- or volumetric-based multi-scale geometric modeling approach [30, 145].

Beam-based models can be generated via functions by defining them in ANSYS. However, this requires high familiarity with the ANSYS Parametric Design Language (APDL) which has the syntax similar to it of the FORTRAN programming language [146, 147]. Moreover, defining different topologies within a same structure in ANSYS is a complex and not intuitive process. Beam-based models should also be preprocessed for AM purposes which introduces imperfections in the models, especially in the nodes [148]. Note that volumetric modelling methods can also be applied to heterogeneous lattice structures as they have the same challenges as bio-inspired structures covered in Subsection 2.2 [87].

As seen in Fig. 21, V-rep modelling mentioned in Subsection 2.2 allows defining V-cells with the same topology but with different parameters, both internal (such as the strut diameter) and external (such as the V-cell transformation matrix). The topology itself must be properly defined, as well as all the parameters that are supposed to change throughout the whole structure [100]. This can prove difficult for many non-strut-based topologies such as triply periodic minimal surfaces. The main bottleneck of geometric modelling of complex shapes – significant computational requirement – remains [149]. Moreover, the topology of the same V-rep model should remain the same and a union of several V-rep models is required for a result with varying topology, while there is no guarantee that two models would fit well one into another.

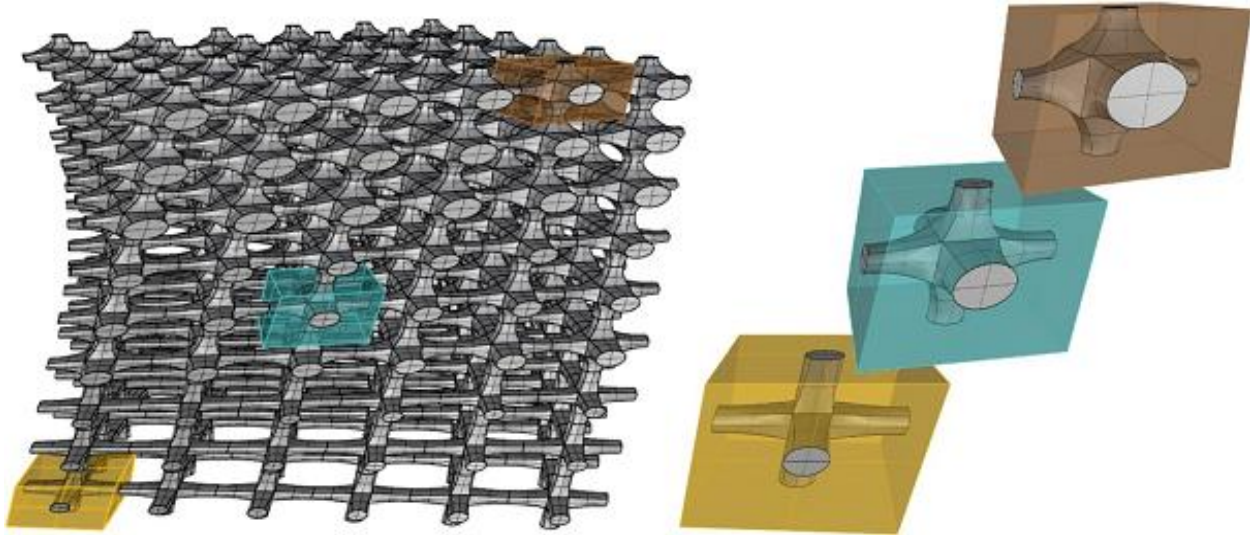

Fig. 21. V-cells of a V-rep model of a heterogeneous lattice [100]

Another geometric modelling technique used in design involves application of F-rep which allows modelling of not only the boundary ($F(X) = 0$) but the interior as well ($F(X) \leq 0$). The majority of F-rep methods are incompatible with other modelling formats and cannot store topology information which makes it nontrivial to produce the designed part with AM techniques [150]. However, some F-rep models, such as skeleton-based implicit surfaces, are fully capable of encoding the topology of the solid [151]. Therefore, it is worth investigating whether such approaches could prove beneficial for geometric modelling of complex geometries.

Defining a heterogeneous lattice structure with different topologies is possible through function-based methods by defining areas corresponding to these topologies and assigning weights to the areas, as seen in Fig. 22a and Fig. 22b, or by defining grading functions which change unit cell properties across the design space, as seen in Fig. 22c [152, 153]. However, there are limitations to this method. Even with weights assigned to every topology, some unit cells appear to be disconnected from each other, which negatively impacts the whole model [154]. Designing such lattice structures is not trivial and challenging for a regular user as this involves defining complex function-based rules. Moreover, it is not clear how to design a hierarchical lattice structure with such an approach, as different functions must be defined at each level [155].

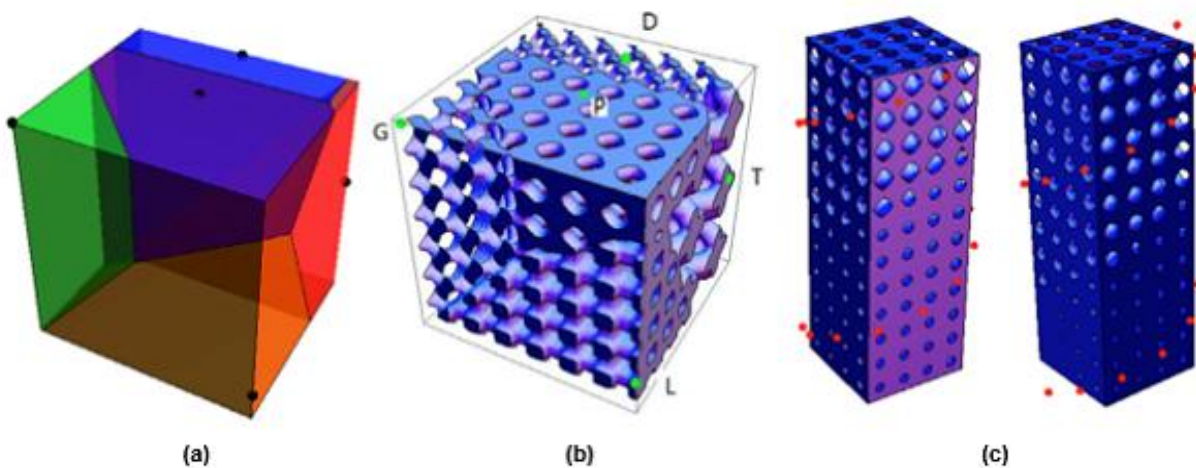

Fig. 22. A heterogeneous lattice can be defined as defining (a) weighted areas corresponding to every topology and (b) applying actual topologies to the regions, and/or (c) changes in unit cell parameters by function-based rules. Permission to reprint from Elsevier copyright 2015 [152].

Nevertheless, having a function to generate a lattice structure has its own advantages. For instance, consider a previously mentioned torus: in F-rep the only thing needed for its definition is its implicit equation in Cartesian coordinates, i.e.

$$\left(\sqrt{x^2 + y^2} - R\right)^2 + z^2 = r^2, \quad (3)$$

where (x, y, z) are the Cartesian coordinates. For another, more complex example, consider a gyroid lattice set by Equation 3 [156]. The gyroid is considered as an example in this work due to its occurrence in nature in, for example, butterfly wings and a liquid-crystalline lipid mesophase [157, 158].

$$\sin(x) \cos(y) + \sin(y) \cos(z) + \sin(z) \cos(x) = 0. \quad (4)$$

In HyperFun – an F-rep programming language [159] – only a few lines of code are required to define and model the whole lattice:

```
my_model(x[3], a[1])
{
    my_model = sin(x[1]) * cos(x[2]) + sin(x[2]) * cos(x[3]) + sin(x[3]) * cos(x[1]);
}
```

Here `my_model` is set to $F(x)$ which defines the boundary surface $F(x) = 0$ in 3D Cartesian coordinates. The resulting surface is illustrated in Fig. 23a.

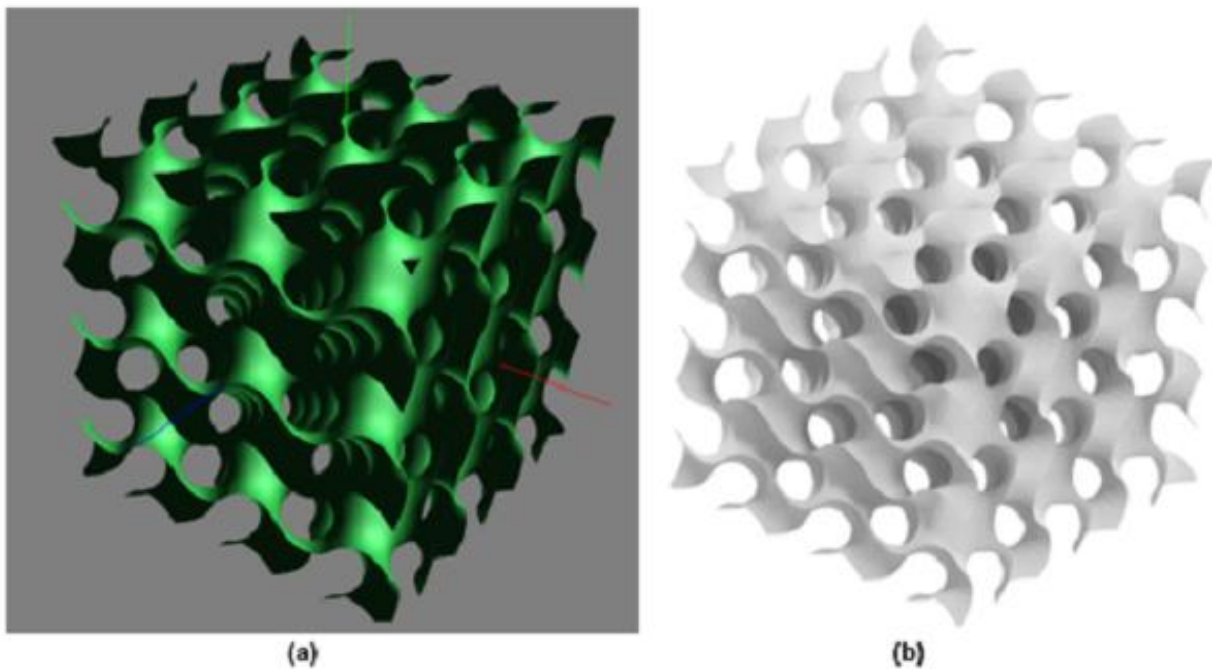

Fig. 23. A gyroid lattice defined by Equation 4: (a) generated by HyperFun language and (b) converted to the STL file format, rendered and ready to be printed

The LSM method described previously in Subsection 2.2 is also applicable to F-rep, as the design space can be sliced into layers and for each layer there can be a 2D function $F(X) \leq 0$ that sets the interior of the solid body for this particular layer [160]. This approach requires defining a step function $S(X)$ that controls the discretization of layers. For example, consider the previously mentioned torus. In this case, for a chosen layer $S_i \subset S$, one would need to define two circles

$$x^2 + y^2 = (R - S(z))^2 \quad \text{and} \quad x^2 + y^2 = (R + S(z))^2, \quad (5)$$

where $S(z)$ serves as the step function and is defined as

$$S(z) = \sqrt{r^2 - z^2} \quad (6)$$

Ideally, $S(X)$ is preferred to be continuous function, but in LSM it is considered discrete. However, for more complicated structures such as lattice structures finding a single equation for $F(X)$ is already challenging, and a continuous representation of $S(X)$ is often replaced by a discrete one [161, 162]. This introduces unnecessary distortion to the model as the model defined in each layer is a continuous and not a discrete function.

Defining a common homogeneous lattice structures requires to define loops to iterate struts and nodes in all three coordinate directions. However, in heterogeneous case, topologies and rules need to be defined as well, which adds complexity and is not intuitive for a designer. This calls for an intuitive and user-friendly heterogeneous structure generation software.

Designing bio-inspired heterogeneous structures is even more ambiguous for a designer, as this process requires understanding the processes that form geometric shapes in nature up to the ability to explicitly define these shapes as functions [163]. Recall the example with brachistochrone curve from the introduction in Section 1: only in the 16th century scientists were able to formulate and solve the problem of finding an equation of brachistochrone curve [164]. In the 21st century there are much more complex examples of bio-inspired functions that are applied to designing complex geometric objects [165, 68], and nowadays functional description of shapes encountered in nature is still not a trivial and often a computationally expensive task [166, 74, 167].

F-rep has another advantage over its alternatives: the functions that are used to model an object can serve as an input to a topology optimization algorithm, thus aiding in finding the optimal parameters for heterogeneous lattice structures [168]. Moreover, it has been identified that topology optimization also requires a novel geometric modelling approach [123].

It is important to make sure that the designed CAD-file can be open using any machine. Nowadays, the STEP file format defined by the ISO 10303 standard is one of the most popular ones as it can be opened with most of the CAD system and can be directly used for manufacturing [169, 170]. However, the stereolithography (STL) file format defined by is dominating the AM market as STL files are commonly used as direct inputs for 3D printers [171]. The gyroid lattice in

Fig. 23a can be exported into a STL file format which can be directly used in AM as seen in Fig. 23b.

3.2 Multi-scale modelling of heterogeneous lattice structures

Similarly to other bio-inspired structures, it is required to consider not only the whole heterogeneous lattice structure in its macro-scale, but also each joint and strut of its lattice as they form its meso-scale [138, 117].

Applying LoD to lattice structures has its own difficulties. One can reduce or increase model complexity by decreasing or increasing, respectively, the amount of polygons needed for its rendering [108]. But when the lattice structure is simplified, i.e. its LoD gets lower, it becomes completely homogenized at some point [172], and when the LoD of a lattice is increase, its size becomes barely manageable, often reaching gigabytes in size, especially in case of heterogeneous lattices [138]. Thus, geometric modelling, design and transferring such structures becomes slow, making the whole process slow.

There are no clear boundaries between LoDs in models that are not generated by explicit modelling techniques. In lattice structures, the only boundary that can be easily associated with a LoD is when a hierarchical lattice structure is considered – essentially, the hierarchy can be associated with a LoDs as illustrated in Fig. 24. Note that hierarchical lattices are common in nature, e.g. the bamboo structure is hierarchical and has inspired producing similar lattice structures using AM [155].

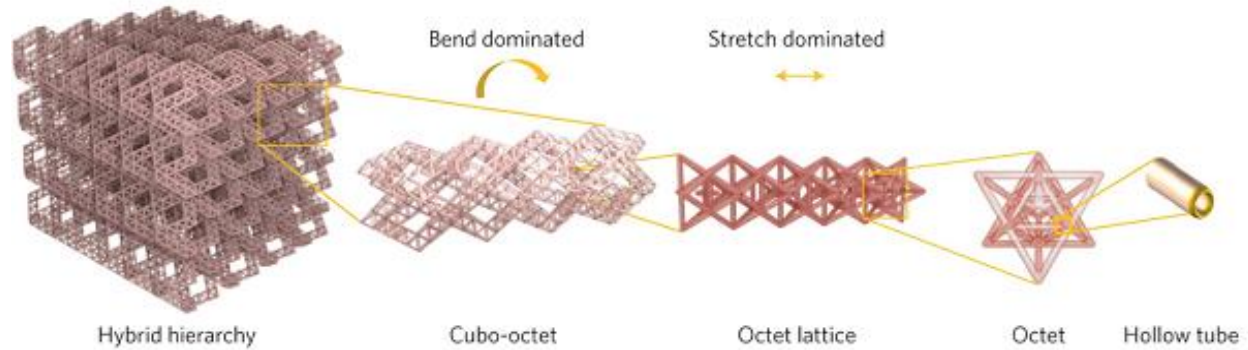

Fig. 24. An example of a hierarchical lattice structure. Note that every next tier in the hierarchy can be associated with a higher level of detail. Permission to reprint from Springer Nature copyright 2016 [173].

Topology optimization algorithms often provide unique solutions to the design of multi-scale structures [174, 122]. The resulting structures can be heavily heterogeneous geometrically, but the question of designing structures of the same complexity or at least modifying the result of topology optimization is still open.

It has been found a hybrid geometric modelling method based on combining voxel representation and F-rep can serve as a way to model and store the topology information of lattice structures including multi-scale ones [121]. However, it also inherits the high computation time spent on voxel modelling and is not yet fit for direct fabrication.

4 A proposed multi-scale geometric modeling framework for bio-inspired complex structures

Summarizing the above analysis of various literature sources, there is a lack of a geometric modeling method (or tool that would support that method) that suits for geometric modelling of complex geometry and shapes such as heterogeneous lattice structures and other bio-inspired complex structures. The issues with multi-scale modelling in parametric modelling of complex geometry have been identified and covered.

F-rep methods covered in this work allow modelling of homogeneous lattice structures with reasonable ease – a simple lattice structure can be modelled as a self-repeating pattern of unit cells made of cylinders. However, there is still a challenge of defining non-explicit heterogeneous lattices and other bio-inspired complex structures, as their modelling requires to have geometric functions corresponding to them defined first. Functions allow modelling of lattice structures with ease. For example, consider a BCC unit cell sketched in Fig. 25. This unit cell can be described as follows:

$$\left[\begin{array}{l}
 x = 0, \quad y = 0 \\
 x = 0, \quad y = b \\
 x = a, \quad y = 0 \\
 x = a, \quad y = b \\
 y = 0, \quad z = 0 \\
 y = 0, \quad z = c \\
 y = b, \quad z = 0 \\
 y = b, \quad z = c \\
 x = 0, \quad z = 0 \\
 x = 0, \quad z = c \\
 x = a, \quad z = 0 \\
 x = a, \quad z = c \\
 \frac{x}{a} = \frac{y}{b} = \frac{z}{c} \\
 \frac{x-a}{-a} = \frac{y}{b} = \frac{z}{c} \\
 \frac{x}{a} = \frac{y}{b} = \frac{z-c}{-c} \\
 \frac{x-a}{-a} = \frac{y}{b} = \frac{z-c}{-c}
 \end{array} \right. \quad \text{for } x \in [0, a], y \in [0, b], c \in [0, c] \quad (7)$$

These unit cells could be positioned to the node points of the lattice defined as a point in Cartesian or other coordinates. In a function-based approach, the lines can easily be replaced by a more complicated equation such as the sine function for example. The nodes of the lattice can also be functionally defined with the most trivial one – a sphere – having a well-known equation. Moreover, as the lines can be replaced with volumetric cylinders, i.e. can form volumetric struts of the lattice, the thickness of these cylinders can be set varying across the whole structure as well as the unit cell bounding parameters a , b , and c . This would also open a possibility to define a lattice inside of another lattice, thus ensuring multi-scale modelling. The user input should be customizable and allow inserting various parameters such as described above.

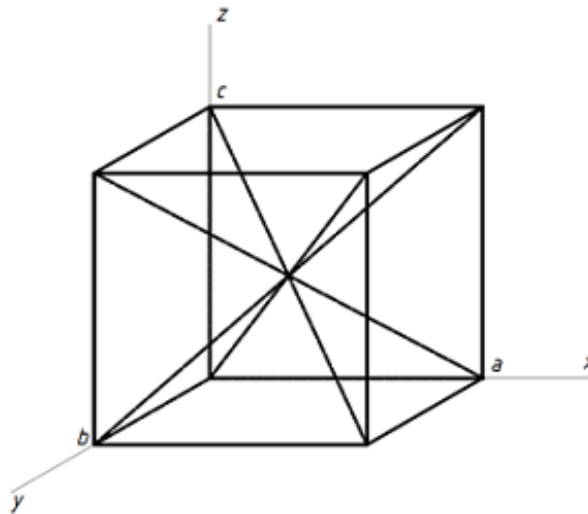

Fig. 25. A BCC unit cell described by Equation 7

There is still a concern regarding defining bio-inspired structures with F-rep. A large variety of shapes appear in nature with most of them being non-trivially defined mathematically such as the brachistochrone curve in Fig. 1c. This can be solved by using polygonal or any other interpolation of functions in order to achieve a certain geometry close to bio-

inspired. Note that normally there is no need to completely copy nature, as geometric shapes in nature are affected by mutations and other perturbations, making them further from the nature-intended form [175]. There is also a concern of some evolutionary developments being useless for the target species. For example, the appendix was notoriously known for bringing unnecessary health issues in human body. Even though the appendix has proved to be useful in a recent research [176], there are still more unnecessary rudimental organs in human body such as the tail bone, the third eyelid, wisdom teeth, etc. Therefore, motivation for choosing the bio-inspired design over the conventional one should be always well justified.

Moreover, there is a potential in application of bio-inspired algorithms and methods to geometry discretization. Combining and integrating together several biological rules related to cell division process is described in Subsection 2.1, such as the bio-inspired geometric modelling approach based on volumetric cells [39]. However, there could be more other nature-based algorithms that can be applied to geometric modelling, as the variety of bio-inspired algorithms in such areas as machine learning and simulations is immerse.

Thus, the tool that could be able to model complex geometric structures such as bio-inspired structures can be developed using F-rep methods. There is also a potential in bio-inspired algorithms applied to model discretization similarly to cell division processes occurring in nature. Summarizing, the potential Functional Bio-inspired and Lattice Geometry Generation software tool (which will be referred to as FBLGen further in this work) could be a result of the research in the intersection of these areas as sketched in Fig. 26.

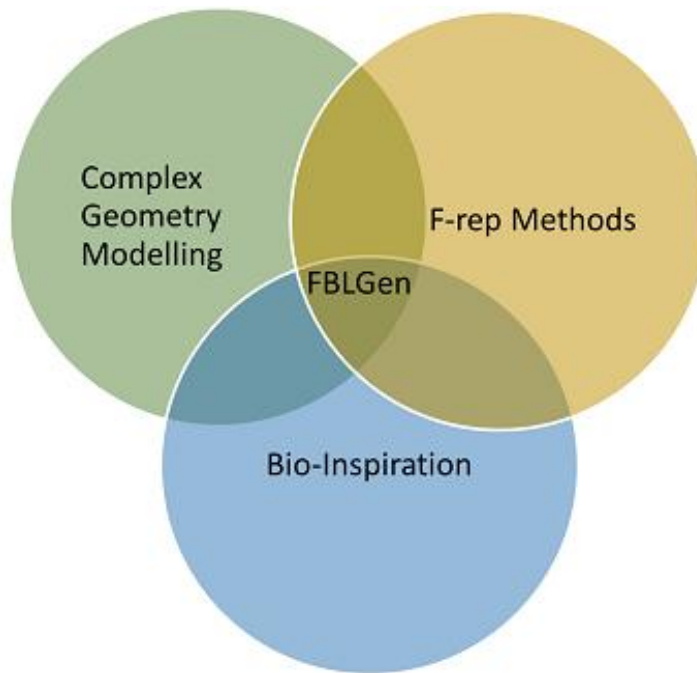

Fig. 26. The ability to model complex geometry (green) using F-rep methods (yellow) supported by bio-inspired algorithms (blue) can result in the function-based lattice generation (FBLGen) software tool

Even though it is sufficient to develop a console-based application for the sake of proving of concept, it is important to eventually ensure that such lattice design software is user-friendly. Thus, it must follow a specific architecture. The goal of an architecture is to identify the requirements that affect the structure of the application [177]. In other words, an architecture bridges the gap between heterogeneous lattice structure requirements and technical requirements by understanding use-cases, and then finding ways to implement these use-cases in a software. As mentioned in Section 2, the design tool shall include a DLL containing a GMK. Moreover, it is a common practice in modern CAD software development to ensure a multi-document interface (MDI) structure, as it helps the designer to operate different

kinds of file formats at the same time [178]. In this work, it is assumed that the MDI structure is required for a function-based heterogeneous lattice modelling tool, as the 3D model and the function editor are open in separate documents. Both top-level and low-level architectures are proposed for the FBLGen tool. In MDI, all documents should be accessed within the single framework on the top level of application architecture as illustrated in Fig. 27.

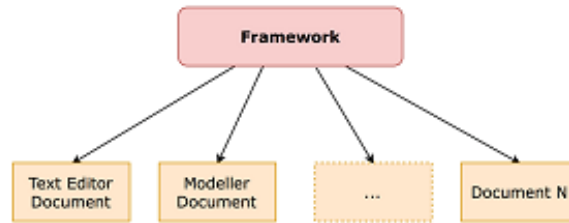

Fig. 27. Top level of the FBLGen architecture

Fig. 28 represents the second – low – level of architecture, where it is important to identify explicit links inside the application. Here the DLL (which contains a GMK) works together with the GUI and the Template Plugin. The GUI is responsible for human-machine interface (HMI), while the Template Plugin allows creation of new documents of different types. The GUI consists of the Framework with various tools such as menu, statusbar, toolbar, etc. The Template Plugin is controlled by the Framework and stores and changes data within the document. It also interacts back with the Framework through the Interface. The Interface sends signals to the Registrator Plugins, which sends signals with the Framework to the application itself.

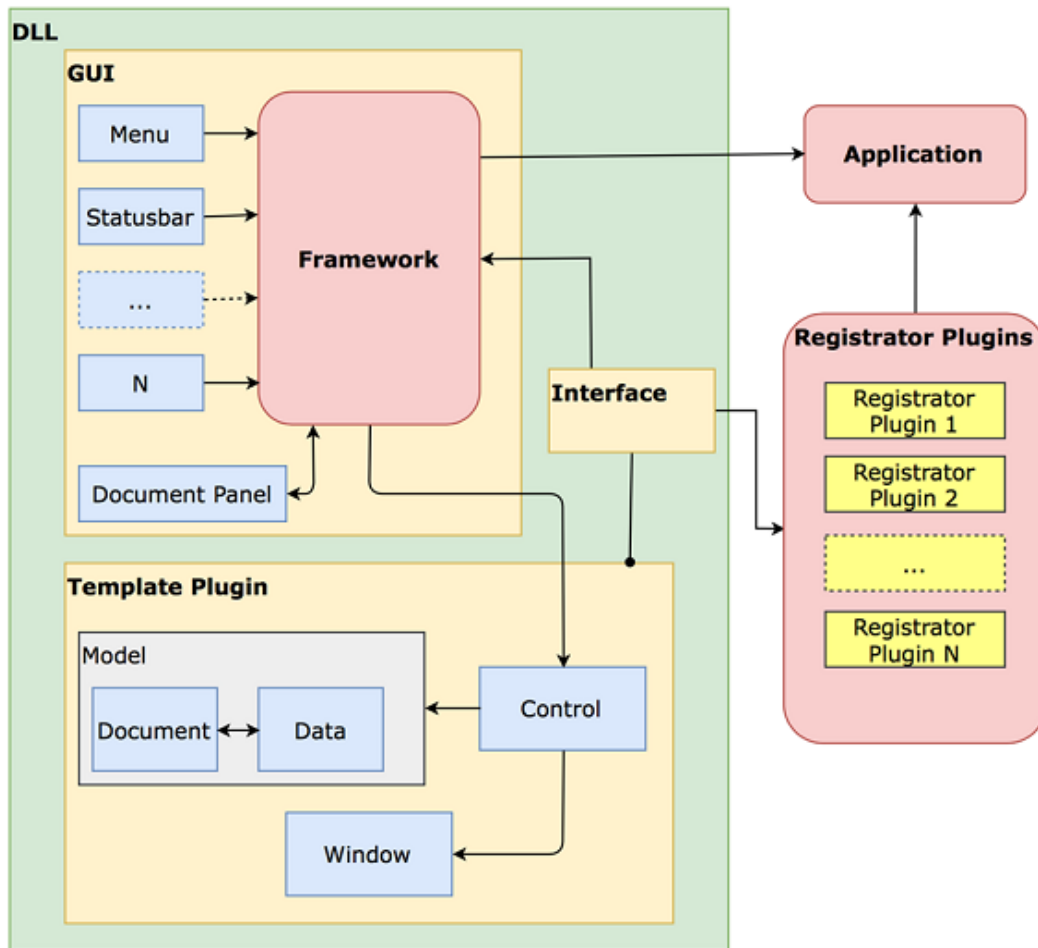

Fig. 28. Low level of the FBLGen architecture

The diagram provided in Fig. 29 shows the interconnections between the window and the manager. The Model, which corresponds to geometric data, may be represented by the Document, which could be seen in the Window by a user. The user sends signals to the General Manager through the Manager Editor to make changes in the Document.

It was decided to develop a prototype of such a tool based on CadQuery tool which enables high parametrization of solid models by scripting them with the Python language, while the GMK is Open CASCADE written in C++ [179]. In an example of a heterogeneous lattice in Fig. 30, a custom script was developed take the following user input: $d_{\min} = 1$ mm – minimum strut diameter in x direction; $d_{\max} = 3$ mm – maximum strut diameter in x direction; $s = 10$ mm – unit cell size; $N = (5, 4, 3)$ – number of unit cells in directions x, y, z . The script then uses a linear function $d(x)$ which depends on d_{\min} and d_{\max} and changes the strut diameter in x direction. Note that the diameter of nodes adapts to user input and is larger where the incoming struts are thicker. It is believed that a certain degree of customizability is required in the user interface to allow user-defined topologies and potentially allow more complex bio-inspired structures.

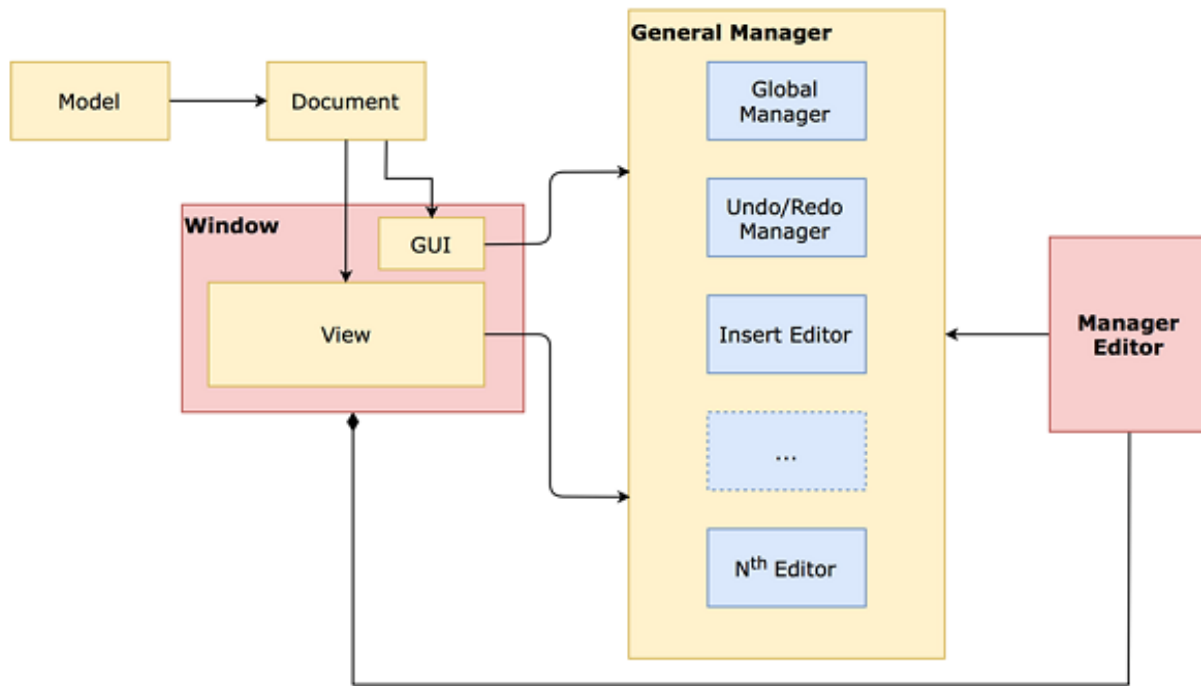

Fig. 29. The diagram representation of the Manager Editor linkage with the Window in the FBLGen tool

5 Conclusions

The paper discussed challenges and opportunities arising in geometric modelling of bio-inspired structures with complex geometry such as heterogeneous lattice structures. It was found that the most widely used geometric modelling methods such as polygonal and voxel-based are significantly challenged to support the amount of the details that the design freedom of AM provides. Geometric objects essentially become datasets full of entries such as mesh/voxel coordinates and shapes which are extremely large to process. It was identified in this review that either these methods would need to be significantly modified, or other methods should be used for highly geometrically complex shapes.

It is found that there is no efficient tool developed to support geometric modelling of such structures. The issues with current geometric modelling methods are identified as related to inability to define different topologies in these methods; inability to correctly model and define the boundaries between topologies; inability to support multi-scale modelling; and general computation efficiency of these methods.

A novel multi-scale geometric modelling framework was proposed to attempt solving these issues in a single software for geometric modelling of complicated bio-inspired structures to be produced by additive manufacturing.

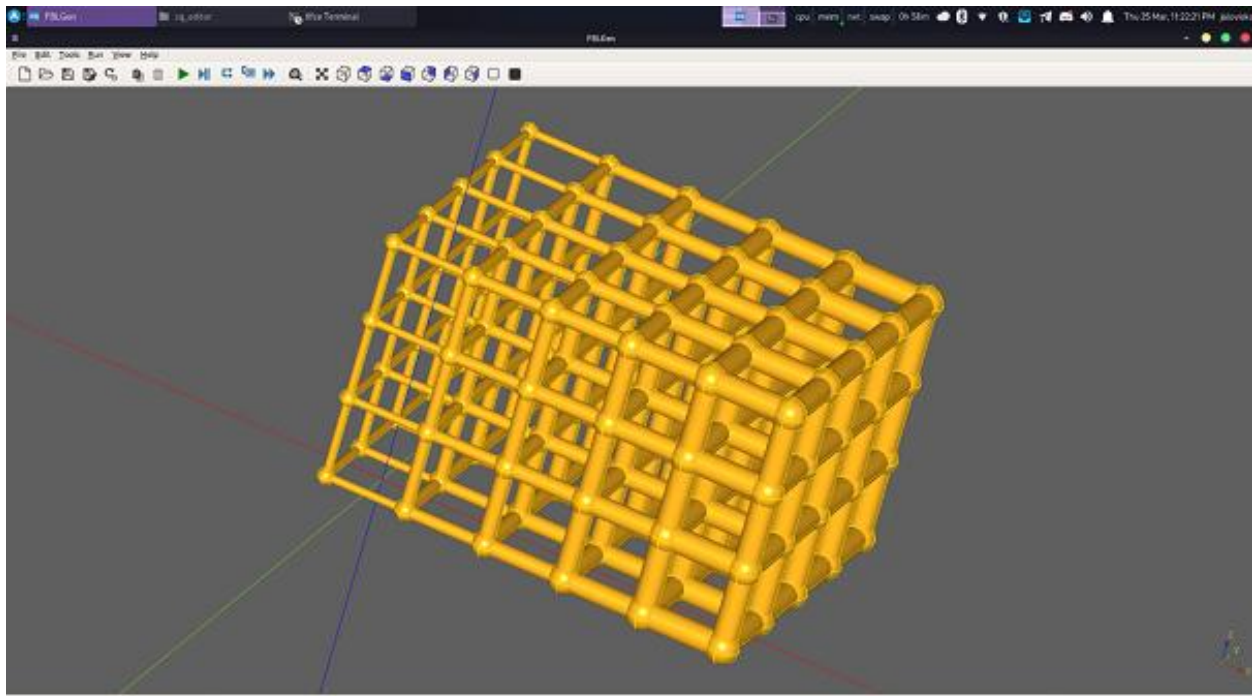

Fig. 30. The prototype of the FBLGen tool used to model a lattice structure with varying strut diameters

The future research will be focused, first of all, on supporting geometric modelling of complex 3D structures such as bio-inspired structures and heterogeneous lattice structures. The possibility of having a bio-inspired geometric modelling algorithm to render bio-inspired structures should be investigated further. The mathematical functions that define geometry in nature are not easily found and depend on properties and characteristics of the living organism and its environment. More research is required to develop a method for defining such functions. The software prototype of the proposed FBLGen tool is planned to be developed further to serve as a minimal viable product for the sake of proving the concept. The concept shall be considered proved in case the bio-inspired modelling method can perform better in terms of quantitative and qualitative results compared to alternatives when applied to real and complicated bio-inspired geometric structures such as heterogeneous lattice structures.

Acknowledgements

This research work is supported by National Sciences and Engineering Research Council of Canada Discovery Grant RGPIN-2018-05971.

References

- [1] Li, Shuo, Hedan Bai, Robert F. Shepherd, and Huichan Zhao. 2019a. "Bio-Inspired Design and Additive Manufacturing of Soft Materials, Machines, Robots, and Haptic Interfaces." *Angewandte Chemie International Edition* 58 (33): 11182–204. <https://doi.org/10.1002/anie.201813402>.
- [2] Weiskittel, Aaron R., John A. Kershaw, Philip V. Hofmeyer, and Robert S. Seymour. 2009b. "Species Differences in Total and Vertical Distribution of Branch- and Tree-Level Leaf Area for the Five Primary Conifer Species in Maine, USA." *Forest Ecology and Management* 258 (7): 1695–1703. <https://doi.org/10.1016/j.foreco.2009.07.035>.
- [3] Fazio, Michael W, Marian. Moffett, and Lawrence. Wodehouse. 2013c. *A World History of Architecture*. Third edit. London SE: Laurence King. <https://mcgill.on.worldcat.org/oclc/813861215>.
- [4] Lutfi, Mohammad. 2018d. "The Effect of Gravitational Field on Brachistochrone Problem." *Journal of Physics: Conference Series* 1028 (June): 012060. <https://doi.org/10.1088/1742-6596/1028/1/012060>.
- [5] Ashby, N., W. E. Brittin, W. F. Love, and W. Wyss. 1975e. "Brachistochrone with Coulomb Friction." *American*

- Journal of Physics* 43 (10): 902–6. <https://doi.org/10.1119/1.9976>.
- [6] Dmitry B. 2016f. “Evening Light, Kiyomizu-Dera Temple, Kyoto.” 2016. https://www.flickr.com/photos/ru_boff/31734103446.
- [7] Monn, Michael A. 2017g. “The Conversation.” Learning New Tricks from Sea Sponges, Nature’s Most Unlikely Civil Engineers. 2017. <https://theconversation.com/learning-new-tricks-from-sea-sponges-natures-most-unlikely-civil-engineers-80373>.
- [8] Li, Longhai, Ce Guo, Yiting Chen, and Yinhe Chen. 2020h. “Optimization Design of Lightweight Structure Inspired by Glass Sponges (Porifera, Hexacnclida) and Its Mechanical Properties.” *Bioinspiration & Biomimetics* 15 (3): 036006. <https://doi.org/10.1088/1748-3190/ab6ca9>.
- [9] Bar-Cohen, Yoseph. 2005i. *Biomimetics. Biologically Inspired Technologies*. 1st ed. Boca Raton, FL: CRC Press. <https://doi.org/10.1201/9780849331633>.
- [10] Kerrick, Dana. 2011j. “Helicopter Maintenance Magazine.” From Wood to Composite Materials The Evolution of the Rotor Blade. 2011. <https://helicoptermaintenancemagazine.com/article/wood-composite-materials-evolution-rotor-blade>.
- [11] Rayker, Karunakar. 2008k. “Honeycomb.” 2008. Honeycomb.
- [12] Redback Aviation. 2017l. “Redback Aviation.” Understanding Rotor Blades - the Rotary Wing. 2017. <http://www.redbackaviation.com/understanding-rotor-blades-the-rotary-wing/>.
- [13] ASTM. 2015m. “ASTM F2792-12a: Standard Terminology for Additive Manufacturing Technologies.” West Conshohocken (PA), United States: ASTM International.
- [14] Dassault Systèmes SE. 2020n. “SOLIDWORKS.” SOLIDWORKS and SW Data Management System Requirements. 2020. <https://www.solidworks.com/sw/support/SystemRequirements.html>.
- [15] Robert McNeel & Associates. 2020o. “Rhino System Requirements.” System Requirements. 2020. https://www.rhino3d.com/6/system_requirements.
- [16] Kamaci, N., and Y. Altunbasak. 2003p. “Performance Comparison of the Emerging H.264 Video Coding Standard with the Existing Standards.” In *2003 International Conference on Multimedia and Expo. ICME '03. Proceedings (Cat. No.03TH8698)*, 1–345. IEEE. <https://doi.org/10.1109/ICME.2003.1220925>.
- [17] Kianian, Babak. 2017q. *Wohlers Report 2017: 3D Printing and Additive Manufacturing State of the Industry, Annual Worldwide Progress Report*. 22nd ed. Wohlers Associates, Inc.
- [18] Attene, Marco. 2018r. “As-Exact-as-Possible Repair of Unprintable STL Files.” *Rapid Prototyping Journal* 24 (5): 855–64. <https://doi.org/10.1108/RPJ-11-2016-0185>.
- [19] Wohlers, Terry T., and Tim Gornet. 2014s. “History of Additive Manufacturing.” *Wohlers Report* 24 (2014): 118.
- [20] Taufik, Mohammad, and Prashant Jain. 2016t. “Additive Manufacturing: Current Scenario.” In *International Conference on Advanced Production and Industrial Engineering, ICAPIE 2016*, 380–86. New Delhi, India.
- [21] Hamelin, R. Douglas, David D. Walden, and Michael E. Krueger. 2010u. “4.4.2 INCOSE Systems Engineering Handbook v3.2: Improving the Process for SE Practitioners.” *INCOSE International Symposium* 20 (1): 532–41. <https://doi.org/10.1002/j.2334-5837.2010.tb01087.x>.
- [22] Edalat, Abbas, and André Lieutier. 2002v. “Foundation of a Computable Solid Modelling.” *Theoretical Computer Science* 284 (2): 319–45. [https://doi.org/10.1016/S0304-3975\(01\)00091-3](https://doi.org/10.1016/S0304-3975(01)00091-3).
- [23] Kou, X.Y., and S.T. Tan. 2007w. “Heterogeneous Object Modeling: A Review.” *Computer-Aided Design* 39 (4): 284–301. <https://doi.org/10.1016/j.cad.2006.12.007>.
- [24] Rosen, David W. 2007x. “Computer-Aided Design for Additive Manufacturing of Cellular Structures.” *Computer-Aided Design and Applications* 4 (5): 585–94. <https://doi.org/10.1080/16864360.2007.10738493>.
- [25] Dimas, Leon S., and Markus J. Buehler. 2014y. “Modeling and Additive Manufacturing of Bio-Inspired Composites with Tunable Fracture Mechanical Properties.” *Soft Matter* 10 (25): 4436. <https://doi.org/10.1039/c3sm52890a>.
- [26] Panda, Biranchi Narayan. 2015z. *Design and Development of Cellular Structure for Additive Manufacturing (PhD Thesis)*. Rourkela, India: National Institute of Technology Rourkela.
- [27] Tang, Yunlong, and Yaoyao Fiona Zhao. 2016aa. “A Survey of the Design Methods for Additive Manufacturing to Improve Functional Performance.” *Rapid Prototyping Journal* 22 (3): 569–90. <https://doi.org/10.1108/RPJ-01-2015-0011>.
- [28] C3D Labs. 2016ab. “C3D Toolkit. Developer Manual.” 2016. https://c3dlabs.com/source/pdf/c3d/2016-C3D_Manual_English.pdf.
- [29] X. Gu, Grace, Isabelle Su, Shruti Sharma, Jamie L. Voros, Zhao Qin, and Markus J. Buehler. 2016ac. “Three-Dimensional-Printing of Bio-Inspired Composites.” *Journal of Biomechanical Engineering* 138 (2). <https://doi.org/10.1115/1.4032423>.

- [30] Savio, Gianpaolo, Stefano Rosso, Roberto Meneghello, and Gianmaria Concheri. 2018ad. “Geometric Modeling of Cellular Materials for Additive Manufacturing in Biomedical Field: A Review.” *Applied Bionics and Biomechanics* 2018: 1654782:1-1654782:14. <https://doi.org/10.1155/2018/1654782>.
- [31] Golovanov, Nikolay. 2014ae. *Geometric Modeling*. CreateSpace Independent Publishing Platform. <https://books.google.ca/books?id=4jUgrgEACAAJ>.
- [32] Gardan, Yvon. 1985af. *Mathematics and CAD: Numerical Methods for CAD*. Cambridge, MA: The MIT Press.
- [33] Ushakov, D. M. 2018ag. *Introduction to the Mathematical Foundations of CAD*. 2nd editio. DMK Press.
- [34] ———. 2012ah. “Isicad.” Russian National 3D Kernel. 2012. http://isicad.net/articles.php?article_num=15189.
- [35] Schnitger Corporation. 2012ai. “New Math. The Hidden Costs of Swapping CAD Kernels.” <http://schnitgercorp.com/wp-content/uploads/2015/08/Hidden-Cost-of-Kernel-Swaps.pdf>.
- [36] Friedenthal, Sanford, Alan Moore, and Rick Steiner. 2015aj. “Residential Security System Example Using the Object-Oriented Systems Engineering Method.” In *A Practical Guide to SysML*, 417–504. Elsevier. <https://doi.org/10.1016/B978-0-12-800202-5.00017-5>.
- [37] Hosaka, Mamoru. 2012ak. *Modeling of Curves and Surfaces in CAD/CAM*. Springer Science and Business Media.
- [38] Pasko, A., V. Adzhiev, A. Sourin, and V. Savchenko. 1995al. “Function Representation in Geometric Modeling: Concepts, Implementation and Applications.” *The Visual Computer* 11 (8): 429–46. <https://doi.org/10.1007/BF02464333>.
- [39] Letov, Nikita, and Yaoyao Fiona Zhao. 2020am. “Volumetric Cells: A Framework for a Bio-Inspired Geometric Modelling Method to Support Heterogeneous Lattice Structures.” *Proceedings of the Design Society: DESIGN Conference 1* (May): 295–304. <https://doi.org/10.1017/dsd.2020.164>.
- [40] Hatcher, Allen. 2002an. *Algebraic Topology*. Cambridge, UK: No eBook available Cambridge University Press.
- [41] Braun, Philipp, Martin Sliwinski, Johannes Hinckeldeyn, and Jochen Kreutzfeldt. 2021ao. “Challenges of CAD Conversion to 3D Development Environments with Respect to Kinematic Dependencies.” In *Proceedings of SIMS 2020*, 215–21. Virtual, Finland. <https://doi.org/10.3384/ecp20176215>.
- [42] Cutanda, Vicente, Peter Møller Juhl, and Finn Jacobsen. 2001ap. “On the Modeling of Narrow Gaps Using the Standard Boundary Element Method.” *The Journal of the Acoustical Society of America* 109 (4): 1296–1303. <https://doi.org/10.1121/1.1350399>.
- [43] FEA for All. 2015aq. “Get the Proper Mesh Density.” 2015. <https://feforall.com/get-proper-mesh-density/>.
- [44] Enterfea. 2017ar. “Correct Mesh Size – a Quick Guide.” 2017. <https://enterfea.com/correct-mesh-size-quick-guide/>.
- [45] Gillebaart, Thijs, Alexander van Zuijlen, and Hester Bijl. 2016as. “Radial Basis Function Mesh Deformation Including Surface Orthogonality.” In *54th AIAA Aerospace Sciences Meeting*, 1–7. Reston, Virginia: American Institute of Aeronautics and Astronautics. <https://doi.org/10.2514/6.2016-1674>.
- [46] Kedward, Laurence, Christian B. Allen, and T. Rendall. 2017at. “Efficient and Exact Mesh Deformation Using Multi-Scale RBF Interpolation.” In *55th AIAA Aerospace Sciences Meeting*, 1–19. Reston, Virginia: American Institute of Aeronautics and Astronautics. <https://doi.org/10.2514/6.2017-0586>.
- [47] Zhao, Zhong, Rong Ma, Lei He, Xinghua Chang, and Laiping Zhang. 2020au. “An Efficient Large-Scale Mesh Deformation Method Based on MPI/OpenMP Hybrid Parallel Radial Basis Function Interpolation.” *Chinese Journal of Aeronautics* 33 (5): 1392–1404. <https://doi.org/10.1016/j.cja.2019.12.025>.
- [48] Stroud, Ian. 2006av. *Boundary Representation Modelling Techniques*. Springer Nature.
- [49] Sánchez-Reyes, Javier. 1995aw. “Quasiconformal Surfaces.” *Computer-Aided Design* 27 (4): 263–75. [https://doi.org/10.1016/0010-4485\(95\)91136-9](https://doi.org/10.1016/0010-4485(95)91136-9).
- [50] Song, Yang, and Elaine Cohen. 2019ax. “Refinement for a Hybrid Boundary Representation and Its Hybrid Volume Completion.” *The SMAI Journal of Computational Mathematics* S5: 3–25. <https://doi.org/10.5802/smai-jcm.49>.
- [51] Wang, Xilu, and Xiaoping Qian. 2014ay. “An Optimization Approach for Constructing Trivariate -Spline Solids.” *Computer-Aided Design* 46 (January): 179–91. <https://doi.org/10.1016/j.cad.2013.08.030>.
- [52] Sasaki, Yuhi, Masahito Takezawa, Seungki Kim, Hiroshi Kawaharada, and Takashi Maekawa. 2017az. “Adaptive Direct Slicing of Volumetric Attribute Data Represented by Trivariate B-Spline Functions.” *The International Journal of Advanced Manufacturing Technology* 91 (5–8): 1791–1807. <https://doi.org/10.1007/s00170-016-9800-0>.
- [53] Rogers, David F. 2001ba. *An Introduction to NURBS: With Historical Perspective*. Morgan Kaufmann.
- [54] Schmidt, Robert, Roland Wüchner, and Kai-Uwe Bletzinger. 2012bb. “Isogeometric Analysis of Trimmed NURBS Geometries.” *Computer Methods in Applied Mechanics and Engineering* 241–244 (October): 93–111. <https://doi.org/10.1016/j.cma.2012.05.021>.
- [55] Boender, Edwin, Willem F. Bronsvort, and Frits H. Post. 1994bc. “Finite-Element Mesh Generation from Constructive-Solid-Geometry Models.” *Computer-Aided Design* 26 (5): 379–92. <https://doi.org/10.1016/0010->

4485(94)90025-6.

- [56] Joan-Arinyo, Robert, Lluís Pérez-Vidal, and Josep Vilaplana-Pastó. 2000bd. "A Simple Algorithm for 2D-Mesh Generation by Domain Composition." In *CAD Tools and Algorithms for Product Design*, 165–77. Berlin, Heidelberg: Springer Berlin Heidelberg. https://doi.org/10.1007/978-3-662-04123-9_11.
- [57] Makhlouf, Aicha Ben, Borhen Louhichi, Mohamed Ali Mahjoub, and Dominique Deneux. 2019be. "Reconstruction of a CAD Model from the Deformed Mesh Using B-Spline Surfaces." *International Journal of Computer Integrated Manufacturing* 32 (7): 669–81. <https://doi.org/10.1080/0951192X.2019.1599442>.
- [58] Raja, Faisal. 2019bf. "Evaluation of Properties of Triply Periodic Minimal Surface Structures Using ANSYS (Master Thesis)." Arizona State University.
- [59] Martin, William, Elaine Cohen, Russell Fish, and Peter Shirley. 2000bg. "Practical Ray Tracing of Trimmed NURBS Surfaces." *Journal of Graphics Tools* 5 (1): 27–52. <https://doi.org/10.1080/10867651.2000.10487519>.
- [60] Raviv, A., and G. Elber. 2001bh. "Interactive Direct Rendering of Trivariate B-Spline Scalar Functions." *IEEE Transactions on Visualization and Computer Graphics* 7 (2): 109–19. <https://doi.org/10.1109/2945.928164>.
- [61] Velivela, Pavan Tejaswi. 2018bi. "Masking Materials and Bio-Inspired Caps for Chemical Etching of Dental Implants." Politecnico di Milano. <https://www.politesi.polimi.it/handle/10589/143135>.
- [62] Autumn, Kellar, Yiching A. Liang, S. Tonia Hsieh, Wolfgang Zesch, Wai Pang Chan, Thomas W. Kenny, Ronald Fearing, and Robert J. Full. 2000bj. "Adhesive Force of a Single Gecko Foot-Hair." *Nature* 405 (6787): 681–85. <https://doi.org/10.1038/35015073>.
- [63] Autumn, K., M. Sitti, Y. A. Liang, A. M. Peattie, W. R. Hansen, S. Sponberg, T. W. Kenny, R. Fearing, J. N. Israelachvili, and R. J. Full. 2002bk. "Evidence for van Der Waals Adhesion in Gecko Setae." *Proceedings of the National Academy of Sciences* 99 (19): 12252–56. <https://doi.org/10.1073/pnas.192252799>.
- [64] Song, Yi, Zhendong Dai, Zhouyi Wang, Aihong Ji, and Stanislav N. Gorb. 2016bl. "The Synergy between the Insect-Inspired Claws and Adhesive Pads Increases the Attachment Ability on Various Rough Surfaces." *Scientific Reports* 6 (1): 26219. <https://doi.org/10.1038/srep26219>.
- [65] Federle, W., Mathis Riehle, Adam S.G. Curtis, and Robert J. Full. 2002bm. "An Integrative Study of Insect Adhesion: Mechanics and Wet Adhesion of Pretarsal Pads in Ants." *Integrative and Comparative Biology* 42 (6): 1100–1106. <https://doi.org/10.1093/icb/42.6.1100>.
- [66] Huang, Jinqun, Sing Yang Chiam, Hui Huang Tan, Shijie Wang, and Wai Kin Chim. 2010bn. "Fabrication of Silicon Nanowires with Precise Diameter Control Using Metal Nanodot Arrays as a Hard Mask Blocking Material in Chemical Etching." *Chemistry of Materials* 22 (13): 4111–16. <https://doi.org/10.1021/cm101121c>.
- [67] Alshegri, Ammar, Natalie Reznikov, Nicolas Piché, Marc D. McKee, Faleh Tamimi, and Jun Song. 2021bo. "Optimization of 3D Network Topology for Bioinspired Design of Stiff and Lightweight Bone-like Structures." *Materials Science and Engineering: C* 123 (April): 112010. <https://doi.org/10.1016/j.msec.2021.112010>.
- [68] Liu, Kesong, and Lei Jiang. 2011bp. "Bio-Inspired Design of Multiscale Structures for Function Integration." *Nano Today* 6 (2): 155–75. <https://doi.org/10.1016/j.nantod.2011.02.002>.
- [69] Schmidt-Nielsen, Bodil, Knut Schmidt-Nielsen, T. R. Houpt, and S. A. Jarnum. 1956bq. "Water Balance of the Camel." *American Journal of Physiology-Legacy Content* 185 (1): 185–94. <https://doi.org/10.1152/ajplegacy.1956.185.1.185>.
- [70] Han, Zhiwu, Zhengzhi Mu, Wei Yin, Wen Li, Shichao Niu, Junqiu Zhang, and Luquan Ren. 2016br. "Biomimetic Multifunctional Surfaces Inspired from Animals." *Advances in Colloid and Interface Science* 234 (August): 27–50. <https://doi.org/10.1016/j.cis.2016.03.004>.
- [71] Nagy, Kenneth A. 2004bs. "Water Economy of Free-Living Desert Animals." *International Congress Series* 1275 (December): 291–97. <https://doi.org/10.1016/j.ics.2004.08.054>.
- [72] Youssef, Belgacem Ben. 2013bt. "Parallelization of a Bio-Inspired Computational Model for the Simulation of 3-D Multicellular Tissue Growth." In *Procedia Computer Science*, 20:391–98. Baltimore (MD), USA: Elsevier. <https://doi.org/10.1016/j.procs.2013.09.292>.
- [73] Fantini, M., M. Curto, and F. De Crescenzo. 2016bu. "A Method to Design Biomimetic Scaffolds for Bone Tissue Engineering Based on Voronoi Lattices." *Virtual and Physical Prototyping* 11 (2): 77–90. <https://doi.org/10.1080/17452759.2016.1172301>.
- [74] Gómez-Gálvez, Pedro, Pablo Vicente-Munuera, Antonio Tagua, Cristina Fortja, Ana M. Castro, Marta Letrán, Andrea Valencia-Expósito, et al. 2018bv. "Scutoids Are a Geometrical Solution to Three-Dimensional Packing of Epithelia." *Nature Communications* 9 (1): 2960. <https://doi.org/10.1038/s41467-018-05376-1>.
- [75] Strand, R. 2004bw. "Surface Skeletons in Grids with Non-Cubic Voxels." In *Proceedings of the 17th International Conference on Pattern Recognition, 2004. ICPR 2004.*, 548-551 Vol.1. Cambridge, UK: IEEE.

- <https://doi.org/10.1109/ICPR.2004.1334195>.
- [76] Laine, S, and T Karras. 2011bx. "Efficient Sparse Voxel Octrees." *IEEE Transactions on Visualization and Computer Graphics* 17 (8): 1048–59. <https://doi.org/10.1109/TVCG.2010.240>.
- [77] Schulz, Henrik. 2009by. "Polyhedral Approximation and Practical Convex Hull Algorithm for Certain Classes of Voxel Sets." *Discrete Applied Mathematics* 157 (16): 3485–93. <https://doi.org/10.1016/j.dam.2009.04.008>.
- [78] Minc, Nicolas, David Burgess, and Fred Chang. 2011bz. "Influence of Cell Geometry on Division-Plane Positioning." *Cell* 144 (3): 414–26. <https://doi.org/10.1016/j.cell.2011.01.016>.
- [79] Schmick, Malte, and Philippe I.H. Bastiaens. 2014ca. "The Interdependence of Membrane Shape and Cellular Signal Processing." *Cell* 156 (6): 1132–38. <https://doi.org/10.1016/j.cell.2014.02.007>.
- [80] Kils, Uwe. 1983cb. "Swimming and Feeding of Antarctic Krill, *Euphausia Superba* – Some Outstanding Energetics and Dynamics – Some Unique Morphological Details." *Ber Polarforsch* 4: 130–55.
- [81] Zhang, Wei, Xiu-Xiu Chen, Yu-Min Liu, Dun-Yi Liu, Yun-Fei Du, Xin-Ping Chen, and Chun-Qin Zou. 2018cc. "The Role of Phosphorus Supply in Maximizing the Leaf Area, Photosynthetic Rate, Coordinated to Grain Yield of Summer Maize." *Field Crops Research* 219 (April): 113–19. <https://doi.org/10.1016/j.fcr.2018.01.031>.
- [82] Jørgensen, Sven Erik. 2002cd. "Explanation of Ecological Rules and Observation by Application of Ecosystem Theory and Ecological Models." *Ecological Modelling* 158 (3): 241–48. [https://doi.org/10.1016/S0304-3800\(02\)00236-3](https://doi.org/10.1016/S0304-3800(02)00236-3).
- [83] Yang, X. S., and Jian J. Zhang. 2005ce. "Modelling and Animating Hand Wrinkles." In *Computational Science - ICCS 2005, 5th International Conference*, 199–206. Atlanta, GA, USA: Springer-Verlag Berlin Heidelberg. https://doi.org/10.1007/11428848_25.
- [84] d'Eon, Eugene, David Luebke, and Eric Enderton. 2007cf. "Efficient Rendering of Human Skin." In *Proceedings of the 18th Eurographics Conference on Rendering Techniques*, 147–157. EGSR'07. Goslar, DEU: Eurographics Association.
- [85] "Altair Acquires SIMSOLID." 2018cg. Altair Engineering. 2018. https://www.altair.com/newsdetail/?news_id=11555.
- [86] Zbiciak, Rafał, and Cezary Grabowik. 2017ch. "Feature Recognition Methods Review." In *Proceedings of the 13th International Scientific Conference. RESRB 2016. Lecture Notes in Mechanical Engineering*, edited by E. Rusiński and D. Pietrusiak, 605–15. Springer, Cham. https://doi.org/10.1007/978-3-319-50938-9_63.
- [87] Aremu, A.O., J.P.J. Brennan-Craddock, A. Panesar, I.A. Ashcroft, R.J.M. Hague, R.D. Wildman, and C. Tuck. 2017ci. "A Voxel-Based Method of Constructing and Skinning Conformal and Functionally Graded Lattice Structures Suitable for Additive Manufacturing." *Additive Manufacturing* 13 (January): 1–13. <https://doi.org/10.1016/j.addma.2016.10.006>.
- [88] Taosong He, Lichan Hong, A. Kaufman, A. Varshney, and S. Wang. 1995cj. "Voxel Based Object Simplification." In *Proceedings Visualization '95*, 296–303. Monterey (CA), USA: IEEE Computer Society Press. <https://doi.org/10.1109/VISUAL.1995.485142>.
- [89] Nooruddin, F.S., and G. Turk. 2003ck. "Simplification and Repair of Polygonal Models Using Volumetric Techniques." *IEEE Transactions on Visualization and Computer Graphics* 9 (2): 191–205. <https://doi.org/10.1109/TVCG.2003.1196006>.
- [90] Telea, Alexandru, and Andrei Jalba. 2011cl. "Voxel-Based Assessment of Printability of 3D Shapes." In *Proceedings of the 10th International Conference on Mathematical Morphology and Its Applications to Image and Signal Processing*, 393–404. Berlin, Germany: Springer-Verlag. https://doi.org/10.1007/978-3-642-21569-8_34.
- [91] Gobert, Christian, Edward W. Reutzel, Jan Petrich, Abdalla R. Nassar, and Shashi Phoha. 2018cm. "Application of Supervised Machine Learning for Defect Detection during Metallic Powder Bed Fusion Additive Manufacturing Using High Resolution Imaging." *Additive Manufacturing* 21 (May): 517–28. <https://doi.org/10.1016/j.addma.2018.04.005>.
- [92] Lorensen, William E., and Harvey E. Cline. 1987cn. "Marching Cubes: A High Resolution 3D Surface Construction Algorithm." *ACM SIGGRAPH Computer Graphics* 21 (4): 163–69. <https://doi.org/10.1145/37402.37422>.
- [93] Newman, Timothy S., and Hong Yi. 2006co. "A Survey of the Marching Cubes Algorithm." *Computers and Graphics* 30 (5): 854–79. <https://doi.org/10.1016/j.cag.2006.07.021>.
- [94] Adalsteinsson, David, and James A. Sethian. 1995cp. "A Fast Level Set Method for Propagating Interfaces." *Journal of Computational Physics* 118 (2): 269–77. <https://doi.org/10.1006/jcph.1995.1098>.
- [95] Kauker, Daniel, Martin Falk, Guido Reina, Anders Ynnerman, and Thomas Ertl. 2016cq. "VoxLink — Combining Sparse Volumetric Data and Geometry for Efficient Rendering." *Computational Visual Media* 2 (1): 45–56. <https://doi.org/10.1007/s41095-016-0034-8>.

- [96] Marcus, Robbin C. 2017cr. "Level-of-Detail Independent Voxel-Based Surface Approximations." Utrecht University. <https://dspace.library.uu.nl/handle/1874/348818>.
- [97] Rom, Michael, and Karl-Heinz Brakhage. 2011cs. "Volume Mesh Generation for Numerical Flow Simulations Using Catmull-Clark and Surface Approximation Methods." Aachen, Germany: Institut für Geometrie und Praktische Mathematik.
- [98] Fuchs, Raphael, Volkmar Welker, and Joachim Hornegger. 2010ct. "Non-Convex Polyhedral Volume of Interest Selection." *Computerized Medical Imaging and Graphics* 34 (2): 105–13. <https://doi.org/10.1016/j.compmedimag.2009.07.002>.
- [99] Massarwi, Fady, and Gershon Elber. 2016cu. "A B-Spline Based Framework for Volumetric Object Modeling." *Computer-Aided Design* 78 (September): 36–47. <https://doi.org/10.1016/j.cad.2016.05.003>.
- [100] Wassermann, Benjamin, Nina Korshunova, Stefan Kollmannsberger, Ernst Rank, and Gershon Elber. 2020cv. "Finite Cell Method for Functionally Graded Materials Based on V-Models and Homogenized Microstructures." *Advanced Modeling and Simulation in Engineering Sciences* 7 (1): 49. <https://doi.org/10.1186/s40323-020-00182-1>.
- [101] Antolin, Pablo, Annalisa Buffa, and Massimiliano Martinelli. 2019cw. "Isogeometric Analysis on V-Reps: First Results." *Computer Methods in Applied Mechanics and Engineering* 355 (October): 976–1002. <https://doi.org/10.1016/j.cma.2019.07.015>.
- [102] Massarwi, Fady, Pablo Antolin, and Gershon Elber. 2019cx. "Volumetric Untrimming: Precise Decomposition of Trimmed Trivariates into Tensor Products." *Computer Aided Geometric Design* 71 (May): 1–15. <https://doi.org/10.1016/j.cagd.2019.04.005>.
- [103] Burkhart, D., B. Hamann, and G. Umlauf. 2010cy. "Iso-Geometric Finite Element Analysis Based on Catmull-Clark Subdivision Solids." *Computer Graphics Forum* 29 (5): 1575–84. <https://doi.org/10.1111/j.1467-8659.2010.01766.x>.
- [104] Hahmann, Stefanie, Georges-Pierre Bonneau, Sébastien Barbier, Gershon Elber, and Hans Hagen. 2012cz. "Volume-Preserving FFD for Programmable Graphics Hardware." *The Visual Computer* 28 (3): 231–45. <https://doi.org/10.1007/s00371-011-0608-5>.
- [105] Ma, Hui, and Klaus-Dieter Schewe. 2011da. "Conceptual Geometric Modelling." In *Handbook of Conceptual Modeling*, edited by David W. Embley and Bernhard Thalheim, 421–40. Berlin, Heidelberg: Springer Berlin Heidelberg. <https://doi.org/10.1007/978-3-642-15865-0>.
- [106] Chen, Falai, Chen Dokken, Thomas A. Grandine, and Géraldine Morin. 2017db. "Geometric Modelling, Interoperability and New Challenges (Dagstuhl Seminar 17221)." *Dagstuhl Reports* 7 (5): 140–68. <https://doi.org/10.4230/DagRep.7.5.140>.
- [107] Rawson, Shelley D., Lee Margetts, Jason K. F. Wong, and Sarah H. Cartmell. 2015dc. "Sutured Tendon Repair; a Multi-Scale Finite Element Model." *Biomechanics and Modeling in Mechanobiology* 14 (1): 123–33. <https://doi.org/10.1007/s10237-014-0593-5>.
- [108] Luebke, David, Martin Reddy, Jonathan D. Cohen, Amitabh Varshney, Benjamin Watson, and Robert Huebner. 2002dd. *Level of Detail for 3D Graphics*. New York (NY), United States: Elsevier.
- [109] Borrmann, A., T.H. Kolbe, A. Donaubaauer, H. Steuer, J.R. Jubierre, and M. Flurl. 2015de. "Multi-Scale Geometric-Semantic Modeling of Shield Tunnels for GIS and BIM Applications." *Computer-Aided Civil and Infrastructure Engineering* 30 (4): 263–81. <https://doi.org/10.1111/mice.12090>.
- [110] Agugiaro, Giorgio, Fabio Remondino, Gabrio Girardi, Jennifer von Schwerin, Heather Richards-Rissetto, and Raffaele De Amicis. 2011df. "A Web-Based Interactive Tool for Multi-Resolution 3D Models of a Maya Archaeological Site." In *ISPRS - International Archives of the Photogrammetry, Remote Sensing and Spatial Information Sciences*, XXXVIII-5/:23–30. <https://doi.org/10.5194/isprsarchives-XXXVIII-5-W16-23-2011>.
- [111] Sacks, Michael S., Amir Khalighi, Bruno Rego, Salma Ayoub, and Andrew Drach. 2017dg. "On the Need for Multi-Scale Geometric Modelling of the Mitral Heart Valve." *Healthcare Technology Letters* 4 (5): 150. <https://doi.org/10.1049/htl.2017.0076>.
- [112] Tian, Fenglin, Wei Hua, Zilong Dong, and Hujun Bao. 2010dh. "Adaptive Voxels: Interactive Rendering of Massive 3D Models." *The Visual Computer* 26 (6–8): 409–19. <https://doi.org/10.1007/s00371-010-0465-7>.
- [113] Limper, M., Y. Jung, J. Behr, and M. Alexa. 2013di. "The POP Buffer: Rapid Progressive Clustering by Geometry Quantization." *Computer Graphics Forum* 32 (7): 197–206. <https://doi.org/10.1111/cgf.12227>.
- [114] "0 FPS." 2018dj. A Level of Detail Method for Blocky Voxels. 2018. <https://0fps.net/2018/03/03/a-level-of-detail-method-for-blocky-voxels/>.
- [115] Seemann, Patrick, Simon Fuhrmann, Stefan Guthe, Fabian Langguth, and Michael Goesele. 2016dk. "Simplification of Multi-Scale Geometry Using Adaptive Curvature Fields," October. <http://arxiv.org/abs/1610.07368>.
- [116] Tao, Wenjin, and Ming C. Leu. 2016dl. "Design of Lattice Structure for Additive Manufacturing." In 2016

- International Symposium on Flexible Automation (ISFA)*, 325–32. Cleveland (OH), United States: IEEE.
<https://doi.org/10.1109/ISFA.2016.7790182>.
- [117] Dong, Guoying, Yunlong Tang, and Yaoyao Fiona Zhao. 2017dm. “A Survey of Modeling of Lattice Structures Fabricated by Additive Manufacturing.” *Journal of Mechanical Design* 139 (10): 100906:1-100906:13.
<https://doi.org/10.1115/1.4037305>.
- [118] Frulloni, E., J.M. Kenny, P. Conti, and L. Torre. 2007dn. “Experimental Study and Finite Element Analysis of the Elastic Instability of Composite Lattice Structures for Aeronautic Applications.” *Composite Structures* 78 (4): 519–28. <https://doi.org/10.1016/j.compstruct.2005.11.013>.
- [119] Martínez, Jonàs, Jérémie Dumas, and Sylvain Lefebvre. 2016do. “Procedural Voronoi Foams for Additive Manufacturing.” *ACM Transactions on Graphics* 35 (4): 44:1-44:12. <https://doi.org/10.1145/2897824.2925922>.
- [120] Schumacher, Christian, Bernd Bickel, Jan Rys, Steve Marschner, Chiara Daraio, and Markus Gross. 2015dp. “Microstructures to Control Elasticity in 3D Printing.” *ACM Transactions on Graphics* 34 (4): 1–13.
<https://doi.org/10.1145/2766926>.
- [121] Tang, Yunlong, Guoying Dong, and Yaoyao Fiona Zhao. 2019dq. “A Hybrid Geometric Modeling Method for Lattice Structures Fabricated by Additive Manufacturing.” *The International Journal of Advanced Manufacturing Technology* 102 (9–12): 4011–30. <https://doi.org/10.1007/s00170-019-03308-x>.
- [122] Liu, Yuan, Shurong Zhuo, Yining Xiao, Guolei Zheng, Guoying Dong, and Yaoyao Fiona Zhao. 2020dr. “Rapid Modeling and Design Optimization of Multi-Topology Lattice Structure Based on Unit-Cell Library.” *Journal of Mechanical Design* 142 (9): 091705:1-15. <https://doi.org/10.1115/1.4046812>.
- [123] Liu, Yuan, Guolei Zheng, Nikita Letov, and Yaoyao Fiona Zhao. 2020ds. “A Survey of Modeling and Optimization Methods for Multi-Scale Heterogeneous Lattice Structures.” *Journal of Mechanical Design*, July, 1–59.
<https://doi.org/10.1115/1.4047917>.
- [124] An, Xiyue, and Hualin Fan. 2016dt. “Hybrid Design and Energy Absorption of Luffa-Sponge-like Hierarchical Cellular Structures.” *Materials & Design* 106 (September): 247–57. <https://doi.org/10.1016/j.matdes.2016.05.110>.
- [125] Douglas, Trevor. 2003du. “A Bright Bio-Inspired Future.” *Science* 299 (5610): 1192–93.
<https://doi.org/10.1126/science.1081791>.
- [126] Jang, Kyung-In, Ha Uk Chung, Sheng Xu, Chi Hwan Lee, Haiwen Luan, Jaewoong Jeong, Huanyu Cheng, et al. 2015dv. “Soft Network Composite Materials with Deterministic and Bio-Inspired Designs.” *Nature Communications* 6 (1): 6566. <https://doi.org/10.1038/ncomms7566>.
- [127] Naboni, Roberto, and Anja Kunic. 2017dw. “Design and Additive Manufacturing of Lattice-Based Cellular Solids at Building Scale.” In *Blucher Design Proceedings*, 369–75. São Paulo: Editora Blucher.
<https://doi.org/10.5151/sigradi2017-058>.
- [128] Zheng, Yongmei. 2019dx. “Biological Design of Materials.” In *Bioinspired Design of Materials Surfaces*, 27–97. Elsevier. <https://doi.org/10.1016/B978-0-12-814843-3.00002-8>.
- [129] Liu, Kesong, Xi Yao, and Lei Jiang. 2010dy. “Recent Developments in Bio-Inspired Special Wettability.” *Chemical Society Reviews* 39 (8): 3240. <https://doi.org/10.1039/b917112f>.
- [130] Hancock, Matthew J., Koray Sekeroglu, and Melik C. Demirel. 2012dz. “Bioinspired Directional Surfaces for Adhesion, Wetting, and Transport.” *Advanced Functional Materials* 22 (11): 2223–34.
<https://doi.org/10.1002/adfm.201103017>.
- [131] Liu, Kesong, Moyuan Cao, Akira Fujishima, and Lei Jiang. 2014ea. “Bio-Inspired Titanium Dioxide Materials with Special Wettability and Their Applications.” *Chemical Reviews* 114 (19): 10044–94.
<https://doi.org/10.1021/cr4006796>.
- [132] Smith, M., Z. Guan, and W.J. Cantwell. 2013eb. “Finite Element Modelling of the Compressive Response of Lattice Structures Manufactured Using the Selective Laser Melting Technique.” *International Journal of Mechanical Sciences* 67 (February): 28–41. <https://doi.org/10.1016/j.ijmecsci.2012.12.004>.
- [133] Kucewicz, Michał, Paweł Baranowski, Jerzy Małachowski, Arkadiusz Popławski, and Paweł Płatek. 2018ec. “Modelling, and Characterization of 3D Printed Cellular Structures.” *Materials & Design* 142 (March): 177–89.
<https://doi.org/10.1016/j.matdes.2018.01.028>.
- [134] Lozanovski, Bill, Martin Leary, Phuong Tran, Darpan Shidid, Ma Qian, Peter Choong, and Milan Brandt. 2019ed. “Computational Modelling of Strut Defects in SLM Manufactured Lattice Structures.” *Materials & Design* 171 (June): 107671. <https://doi.org/10.1016/j.matdes.2019.107671>.
- [135] Leonardi, Francesco, Serena Graziosi, Riccardo Casati, Francesco Tamburrino, and Monica Bordegoni. 2019ee. “Additive Manufacturing of Heterogeneous Lattice Structures: An Experimental Exploration.” *Proceedings of the Design Society: International Conference on Engineering Design* 1 (1): 669–78. <https://doi.org/10.1017/dsi.2019.71>.

- [136] Gümrük, R., and R.A.W. Mines. 2013ef. “Compressive Behaviour of Stainless Steel Micro-Lattice Structures.” *International Journal of Mechanical Sciences* 68 (March): 125–39. <https://doi.org/10.1016/j.ijmecsci.2013.01.006>.
- [137] Kale, Sameer, Navid Khani, Ali Nadernezhad, and Bahattin Koc. 2017eg. “Modeling and Additive Manufacturing of Biomimetic Heterogeneous Scaffold.” *Procedia CIRP* 65: 48–55. <https://doi.org/10.1016/j.procir.2017.04.010>.
- [138] Tang, Yunlong, Guoying Dong, Qinxue Zhou, and Yaoyao Fiona Zhao. 2018ch. “Lattice Structure Design and Optimization with Additive Manufacturing Constraints.” *IEEE Transactions on Automation Science and Engineering* 15 (4): 1546–62. <https://doi.org/10.1109/TASE.2017.2685643>.
- [139] Yang, Sheng, Yunlong Tang, and Yaoyao Fiona Zhao. 2015ei. “A New Part Consolidation Method to Embrace the Design Freedom of Additive Manufacturing.” *Journal of Manufacturing Processes* 20 (October): 444–49. <https://doi.org/10.1016/j.jmapro.2015.06.024>.
- [140] Kurtz, Aidan. 2015ej. “Intralattice. Case Studies.” 2015. http://intralattice.com/case_studies/.
- [141] Tang, Yunlong, Sheng Yang, and Yaoyao Fiona Zhao. 2016ek. “Design Method for Conformal Lattice-Skin Structure Fabricated by AM Technologies.” In *Volume 1A: 36th Computers and Information in Engineering Conference*, V01AT02A037. Charlotte (NC), United States: American Society of Mechanical Engineers. <https://doi.org/10.1115/DETC2016-59738>.
- [142] F EQUALS F LLC. 2019el. “F=f: Crystallon.” 2019. <http://fequalsf.blogspot.com/p/crystallon.html>.
- [143] García-Domínguez, Amabel, Juan Claver, and Miguel A. Sebastián. 2020em. “Optimization Methodology for Additive Manufacturing of Customized Parts by Fused Deposition Modeling (FDM). Application to a Shoe Heel.” *Polymers* 12 (9): 2119:1-30. <https://doi.org/10.3390/polym12092119>.
- [144] General Lattice. 2020en. “Additive Manufacturing - Design Studio.” Studio. 2020. <https://www.generallattice.com/studio>.
- [145] Wehner, Michael, Ryan L. Truby, Daniel J. Fitzgerald, Bobak Mosadegh, George M. Whitesides, Jennifer A. Lewis, and Robert J. Wood. 2016eo. “An Integrated Design and Fabrication Strategy for Entirely Soft, Autonomous Robots.” *Nature* 536 (7617): 451–55. <https://doi.org/10.1038/nature19100>.
- [146] Chen, Wenjong, Xiaonan Zheng, and Shutian Liu. 2018ep. “Finite-Element-Mesh Based Method for Modeling and Optimization of Lattice Structures for Additive Manufacturing.” *Materials* 11 (11): 2073. <https://doi.org/10.3390/ma11112073>.
- [147] University of Alberta. 2001eq. “University of Alberta ANSYS Tutorial.” ANSYS Command File Programming Features. 2001. <https://sites.ualberta.ca/~wmoussa/AnsysTutorial/CL/Features.html>.
- [148] Portela, Carlos M., Julia R. Greer, and Dennis M. Kochmann. 2018er. “Impact of Node Geometry on the Effective Stiffness of Non-Slender Three-Dimensional Truss Lattice Architectures.” *Extreme Mechanics Letters* 22 (July): 138–48. <https://doi.org/10.1016/j.eml.2018.06.004>.
- [149] Savio, Gianpaolo, Roberto Meneghello, and Gianmaria Concheri. 2019es. “Design of Variable Thickness Triply Periodic Surfaces for Additive Manufacturing.” *Progress in Additive Manufacturing* 4 (3): 281–90. <https://doi.org/10.1007/s40964-019-00073-x>.
- [150] Pasko, Alexander, Oleg Fryazinov, Turlif Vilbrandt, Pierre-Alain Fayolle, and Valery Adzhiev. 2011et. “Procedural Function-Based Modelling of Volumetric Microstructures.” *Graphical Models* 73 (5): 165–81. <https://doi.org/10.1016/j.gmod.2011.03.001>.
- [151] Cartwright, R., V. Adzhiev, A.A. Pasko, Y. Goto, and T.L. Kunii. 2005eu. “Web-Based Shape Modeling with HyperFun.” *IEEE Computer Graphics and Applications* 25 (2): 60–69. <https://doi.org/10.1109/MCG.2005.49>.
- [152] Yang, Nan, Yanling Tian, and Dawei Zhang. 2015ev. “Novel Real Function Based Method to Construct Heterogeneous Porous Scaffolds and Additive Manufacturing for Use in Medical Engineering.” *Medical Engineering and Physics* 37 (11): 1037–46. <https://doi.org/10.1016/j.medengphy.2015.08.006>.
- [153] Li, Dawei, Wenhe Liao, Ning Dai, Guoying Dong, Yunlong Tang, and Yi Min Xie. 2018ew. “Optimal Design and Modeling of Gyroid-Based Functionally Graded Cellular Structures for Additive Manufacturing.” *Computer-Aided Design* 104 (November): 87–99. <https://doi.org/10.1016/j.cad.2018.06.003>.
- [154] Wang, Yiqiang, Lei Zhang, Stephen Daynes, Hongying Zhang, Stefanie Feih, and Michael Yu Wang. 2018ex. “Design of Graded Lattice Structure with Optimized Mesostructures for Additive Manufacturing.” *Materials & Design* 142 (March): 114–23. <https://doi.org/10.1016/j.matdes.2018.01.011>.
- [155] Liu, Xingchen, and Vadim Shapiro. 2018ey. “Multiscale Shape–Material Modeling by Composition.” *Computer-Aided Design* 102 (September): 194–203. <https://doi.org/10.1016/j.cad.2018.04.024>.
- [156] Schoen, Alan Hugh. 1970ez. *Infinite Periodic Minimal Surfaces without Self-Intersections*. Washington, D. C.: National Aeronautics and Space Administration (NASA). <https://ntrs.nasa.gov/archive/nasa/casi.ntrs.nasa.gov/19700020472.pdf>.

- [157] Gan, Zongsong, Mark D. Turner, and Min Gu. 2016fa. "Biomimetic Gyroid Nanostructures Exceeding Their Natural Origins." *Science Advances* 2 (5): e1600084. <https://doi.org/10.1126/sciadv.1600084>.
- [158] Longley, William, and Thomas J. McIntosh. 1983fb. "A Bicontinuous Tetrahedral Structure in a Liquid-Crystalline Lipid." *Nature* 303 (5918): 612–14. <https://doi.org/10.1038/303612a0>.
- [159] Adzhiev, Valery, Robert Cartwright, Eric Fausett, Anatoli Ossipov, Alexander A. Pasko, and Vladimir V. Savchenko. 1999fc. "HyperFun Project: Language and Software Tools for F-Rep Shape Modeling." *Computer Graphics and Geometry* 1: 75–100.
- [160] Tereshin, Alexander, Valery Adzhiev, Oleg Fryazinov, and Alexander Pasko. 2019fd. "Hybrid Function Representation with Distance Properties." In *Eurographics 2019 - Short Papers*, edited by Paolo Cignoni and Eder Miguel, 17–20. Genoa, Italy: The Eurographics Association. <https://doi.org/10.2312/egs.20191004>.
- [161] Katopodes, Nikolaos D. 2019fe. "Level Set Method." In *Free-Surface Flow*, 804–28. Elsevier. <https://doi.org/10.1016/B978-0-12-815485-4.00019-X>.
- [162] Kawamoto, Reid, Edward Andò, Gioacchino Viggiani, and José E. Andrade. 2016ff. "Level Set Discrete Element Method for Three-Dimensional Computations with Triaxial Case Study." *Journal of the Mechanics and Physics of Solids* 91 (June): 1–13. <https://doi.org/10.1016/j.jmps.2016.02.021>.
- [163] Miyamoto, Yoshinari, W A Kaysser, B H Rabin, Akira Kawasaki, and René G Ford. 2013fg. *Functionally Graded Materials: Design, Processing and Applications*. Vol. 5. Springer Science & Business Media.
- [164] Boyer, C. B., and U. C. Merzbach. 1991fh. *A History of Mathematics*. 2nd ed. New York (NY), United States: Wiley.
- [165] Egan, Paul, Robert Sinko, Philip R. LeDuc, and Sinan Ketten. 2015fi. "The Role of Mechanics in Biological and Bio-Inspired Systems." *Nature Communications* 6 (1): 7418. <https://doi.org/10.1038/ncomms8418>.
- [166] Voss, Richard F. 1988fj. "Fractals in Nature: From Characterization to Simulation." In *The Science of Fractal Images*, edited by Heinz-Otto Peitgen and Dietmar Saupe, 21–70. New York, NY: Springer New York. https://doi.org/10.1007/978-1-4612-3784-6_1.
- [167] Zhou, Zhenru, Herve Alégot, and Kenneth D. Irvine. 2019fk. "Oriented Cell Divisions Are Not Required for Drosophila Wing Shape." *Current Biology* 29 (5): 856–864.e3. <https://doi.org/10.1016/j.cub.2019.01.044>.
- [168] Cheng, Lin, Jiayi Bai, and Albert C. To. 2019fl. "Functionally Graded Lattice Structure Topology Optimization for the Design of Additive Manufactured Components with Stress Constraints." *Computer Methods in Applied Mechanics and Engineering* 344 (February): 334–59. <https://doi.org/10.1016/j.cma.2018.10.010>.
- [169] ANSI. 2016fm. "ISO 10303-21:2016. Industrial Automation Systems And Integration - Product Data Representation And Exchange - Part 21: Implementation Methods: Clear Text Encoding Of The Exchange Structure." ANSI. <https://webstore.ansi.org/Standards/ISO/ISO10303212016>.
- [170] Chang, Kuang-Hua. 2014fn. *Product Design Modeling Using CAD/CAE: The Computer Aided Engineering Design Series*. Academic Press.
- [171] Grimm, Todd. 2004fo. *User's Guide to Rapid Prototyping*. Society of Manufacturing Engineers.
- [172] PTC. 2019fp. "Material Homogenization for Lattice Simulation in Additive Manufacturing." 2019. https://support.ptc.com/help/creo/creo_pma/r6.0/usascii/whats_new_pma/addmanu-material_homogenization_lattice_simulation.html.
- [173] Zheng, Xiaoyu, William Smith, Julie Jackson, Bryan Moran, Huachen Cui, Da Chen, Jianchao Ye, et al. 2016fq. "Multiscale Metallic Metamaterials." *Nature Materials* 15 (10): 1100–1106. <https://doi.org/10.1038/nmat4694>.
- [174] Antolin, Pablo, Annalisa Buffa, Elaine Cohen, John F. Dannenhoffer, Gershon Elber, Stefanie Elgeti, Robert Haimes, and Richard Riesenfeld. 2019fr. "Optimizing Micro-Tiles in Micro-Structures as a Design Paradigm." *Computer-Aided Design* 115 (October): 23–33. <https://doi.org/10.1016/j.cad.2019.05.020>.
- [175] Liu, Tsung-Li, Srigokul Upadhyayula, Daniel E. Milkie, Ved Singh, Kai Wang, Ian A. Swinburne, Kishore R. Mosaliganti, et al. 2018fs. "Observing the Cell in Its Native State: Imaging Subcellular Dynamics in Multicellular Organisms." *Science* 360 (6386): eaaq1392. <https://doi.org/10.1126/science.aaq1392>.
- [176] Smith, Heather F., William Parker, Sanet H. Kotzé, and Michel Laurin. 2017ft. "Morphological Evolution of the Mammalian Cecum and Cecal Appendix." *Comptes Rendus Palevol* 16 (1): 39–57. <https://doi.org/10.1016/j.crpv.2016.06.001>.
- [177] Bass, Len, Paul Clements, and Rick T A - T T - Kazman. 2013fu. "Software Architecture in Practice." SEI Series in Software Engineering. Upper Saddle River, NJ: Addison-Wesley. <http://proquest.safaribooksonline.com/9780132942799>.
- [178] C3D Labs. 2020fv. "C3D Toolkit." Multi-Thread Support Arrives in C3D Toolkit. 2020. <https://c3dlabs.com/en/blog/tech-tips/multi-thread-support-arrives-in-c3d-toolkit/>.

- [179] Urbańczyk, Adam, Jeremy Wright, Dave Cowden, Innovations Technology Solutions, Hasan Yavuz Özderya, Marcus Boyd, Bruno Agostini, et al. 2021fw. "CadQuery/Cadquery: CadQuery 2.1." 2021. <https://doi.org/10.5281/zenodo.4498634>.

Figure Captions List

- Fig. 1 (a) Branches of a conifer tree, (b) the roof of the Kiyomizu-dera temple in Kyoto, Japan [6], (c) brachistochrone curve – an optimal curve of fastest descent – to prevent rainfall water from staying on them
- Fig. 2 (a) The intricate skeleton of glass sponge [7], (b) the Eiffel Tower in Paris [7], (c) bio-inspired structure and honeycomb structures, (d) the compression vs. displacement curves for three bio-inspired structures. Permission to reprint from IOP copyright [8].
- Fig. 3 (a) The honeycomb structure [11] and (b) the cross section view of composite rotor blade [12]
- Fig. 4 Committed life cycle cost versus time. Permission to reprint from John Wiley and Sons copyright 2014 [21].
- Fig. 5 Two closed 2-manifolds: (a) An oriented 2-manifold of genus 1 (torus) $T = M_1^2$ and (b) a non-oriented 2-manifold of genus 2 (Klein's bottle) N_2^2 [40]
- Fig. 6 Model complexity affecting computation expense of rendering a surface mesh [43]
- Fig. 7 Dependency of errors of geometric mesh representation (a) on calculation time and (b) on finite element size [44]
- Fig. 8 The conceptual sketch of a gecko inspired surface that sticks to the implant surface [61]
- Fig. 9 (a) Two conceptual designs inspired by an insect claw (ant's claw) and (b) the conceptual design of the dental implant masking/cap [61]
- Fig. 10 Render of a protective cap inspired by an insect claw (ant's claw) [61]
- Fig. 11 Two scutoids (a) shown transparent separately and (b) shown opaque and transitioning one into another. Permission to reprint from Springer Nature copyright 2018 [74].
- Fig. 12 The bio-inspired geometric modelling algorithm based on the long axis rule and the surface-to-volume ratio minimization rule observed in nature [39]
- Fig. 13 A close-up on human skin
- Fig. 14 A mesh of non-convex geometry
- Fig. 15 A torus is constructed using five solids of revolution in V-rep modelling [100]
- Fig. 16 (a) A transformation \mathcal{N} of a cubic finite element to a new shape and (b) a geometric modelling of a structure with different stages of refinement with iso-geometric finite elements. Permission to reprint from John Wiley and Sons copyright 2010 [103].
- Fig. 17 Reducing the complexity of a 3D model by decreasing its level of detail that directly corresponds to the number of polygons required to render the model. Permission to reprint from Elsevier copyright 2002 [108].
- Fig. 18 Levels of detail associated with Boolean operations in CAD. Permission to reprint from John Wiley and Sons copyright 2014 [109].
- Fig. 19 (a) A heterogeneous and (b) a homogeneous lattice structures [121]
- Fig. 20 Tire designs with different lattice topologies, which include (a) bare design space, (b) grid lattice, (c) X lattice, and (d) vintiles lattice [140]
- Fig. 21 V-cells of a V-rep model of a heterogeneous lattice [100]
- Fig. 22 A heterogeneous lattice can be defined as defining (a) weighted areas corresponding to every topology and (b) applying actual topologies to the regions, and/or (c) changes in unit cell parameters by function-based rules. Permission to reprint from Elsevier copyright 2015 [152].
- Fig. 23 A gyroid lattice defined by Equation 4: (a) generated by HyperFun language and (b) converted to the STL file format, rendered and ready to be printed
- Fig. 24 An example of a hierarchical lattice structure. Note that every next tier in the hierarchy can be associated with a higher level of detail. Permission to reprint from Springer Nature copyright 2016 [173].
- Fig. 25 A BCC unit cell described by Equation 7
- Fig. 26 The ability to model complex geometry (green) using F-rep methods (yellow) supported by bio-inspired algorithms (blue) can result in the function-based lattice generation (FBLGen) software tool
- Fig. 27 Top level of the FBLGen architecture
- Fig. 28 Low level of the FBLGen architecture
- Fig. 29 The diagram representation of the Manager Editor linkage with the Window in the FBLGen tool

Fig. 30 The prototype of the FBLGen tool used to model a lattice structure with varying strut diameters