



HAL
open science

Comparative Study of High-Throughput Technologies for Next-Generation Satellite On-Board Networks

Pierre-Julien Chaine, Marc Boyer, Claire Pagetti, Franck Wartel

► **To cite this version:**

Pierre-Julien Chaine, Marc Boyer, Claire Pagetti, Franck Wartel. Comparative Study of High-Throughput Technologies for Next-Generation Satellite On-Board Networks. DATA systems in Aerospace (DASIA), Sep 2021, Bucarest, France. hal-03625035

HAL Id: hal-03625035

<https://hal.science/hal-03625035>

Submitted on 30 Mar 2022

HAL is a multi-disciplinary open access archive for the deposit and dissemination of scientific research documents, whether they are published or not. The documents may come from teaching and research institutions in France or abroad, or from public or private research centers.

L'archive ouverte pluridisciplinaire **HAL**, est destinée au dépôt et à la diffusion de documents scientifiques de niveau recherche, publiés ou non, émanant des établissements d'enseignement et de recherche français ou étrangers, des laboratoires publics ou privés.

Comparative Study of High-Throughput Technologies for Next-Generation Satellite On-Board Networks

Pierre-Julien CHAINE
Airbus Defence and Space
Toulouse, FRANCE
pierre-julien.chaine@airbus.com

Marc BOYER
ONERA
Toulouse, FRANCE
marc.boyer@onera.fr

Claire PAGETTI
ONERA
Toulouse, FRANCE
claire.pagetti@onera.fr

Franck WARTEL
Airbus Defence and Space
Toulouse, FRANCE
franck.wartel@airbus.com

Abstract—The spacecraft industry is facing a new challenge: new missions and customers require always more on-board performance. The current satellite network technologies will not be able to handle this increasing demand for long which leads the spacecraft industry to consider an upgrade of their satellite on-board networks. One opportunity has appeared through the use of Ethernet technologies to benefit from COTS components of a mass market. Another one has appeared with SpaceFibre, a space-enabled high-throughput networking technology. In this paper we discuss the suitability of several Ethernet technologies/standards as well as SpaceFibre with respect to the requirements of a satellite network in a qualitative approach. We compare Ethernet, ARINC 664, TTEthernet, Time Sensitive Networking and SpaceFibre under three properties i.e. their quality of service capabilities, their synchronization capabilities and their fault tolerance capabilities.

This paper only deals with SpaceFibre. The other technologies have already been discussed in [1].

Index Terms—Embedded Networks, Real-Time Networks, Satellite, TSN, ARINC 664, TTEthernet, Ethernet, SAVOIR, SpaceFibre

I. SATELLITE CONTEXT

A. Context

In accordance with the ever-expanding volume of data generated and handled by ground-level equipments (telephone, cars, scientific instruments, etc.), satellites must be capable of *producing* and *transmitting* massive amounts of data in order to meet their users' requirements. While improving the performance of data production is straightforward since instruments with such capabilities are already available on the market (e.g. COTS multi-gigabit camera, etc.); improving the performance of the on-board networks carrying that data remains complex. That is this paper focuses on next-generation satellite embedded networks.

B. Current Satellite On-Board Network

In a generic satellite architecture, the on-board network is typically "composed" of two networks: *platform* and *payload*. Each of these networks fulfils diverging and sometimes contrasting needs.

On the one hand, the *platform network* is in charge of conveying all the necessary information used to guarantee the nominal behaviour of the satellite. It transmits data from sensors (position, magnetic field, temperature, etc.) as well as, among others, flight control commands. This kind of traffic, often described as *time critical traffic* requires bounded latency and low jitter communications. However, due to the small size and small volume of messages, a low data rate is enough to achieve the platform needs. In general, the platform network is implemented using a dual MIL-STD-1553 bus [2] or CAN [3] bus.

On the other hand, the *payload network* requires a very high data rate in order to convey the huge amount of raw data generated by the payload instruments such as pictures from telescopes, telemeters from weather sensor or IoT (*Internet of Things*) data. The constraints are less stringent for a payload network: a delay in the packet communication path will not impact the nominal behaviour of the satellite. The payload network is based in general on SpaceWire [4].

C. Reason for a Change

Although the actual architecture works perfectly fine, it has started to show its limits: new instruments and more generally new equipments are capable of generating gigabits of data that the network cannot handle in its current version i.e. 100Mbits/s on a SpaceWire network. Using a gigabit-capable network could allow satellite users to access this huge amount of raw data. At European Space Agency level, SpaceFibre is the high-throughput networking technology successor of SpaceWire, it is hence naturally considered in this study.

Nevertheless, SpaceWire bus (and SpaceFibre) is only used in the spacecraft industry, thus its development and updates are quite expensive, in particular in terms of non-recurring costs. Using a technology based on COTS - *Commercial-off-the-shelves* - components, or IPs - *Semiconductor Intellectual Property Cores* (instantiated into specific space oriented hardware), shared, for some parts or as a whole, with other industrial sectors (automotive, industrial automation, aeronautics, etc.) could help lower the overall cost of the satellite network. Having a wide-spread technology could also facilitate the

interaction between the spacecraft industry and the academic world. This is the reason why we also focus on Ethernet-based technologies.

Moreover, adding more mechanisms at network level (ISO Level 2) could ease the integration of an increasing number of equipments on-board and reduce the development effort to be done at application level. Indeed, design would be simplified as the network would be seen as a black-box from an application point of view, with one or more Service Access Points to interact with it. The network would hence provide properties (introduced in the following sections) guaranteed to the application.

The expected properties and requirements of this future on-board network are the subject of the next section.

II. PROBLEMATIC

A. Identification of expected properties of the future network

In order to compare different candidates for the upgrade of the satellite network, we identify, in this paper, three "properties" that the future network should have. We remind the reader that these properties shall be provided at ISO level 2 i.e. MAC level. In this paper, we will analyse the capabilities of SpaceFibre with respect to these properties. In [1], the suitability of the other candidates were discussed. For each property, we define criteria that will be used to determine whether a property is satisfied or not. Let us now introduce the properties and associated criteria.

Property 1: Mixed Quality of Service - Mixed QoS

Capability of the network system to convey, on the same equipment, several flows with different characteristics (e.g. data rate, min/max packet size, deadline, jitter).

For instance, a network satisfying Prop. 1 shall be able to convey, with the same equipments low data rate with low jitter and high data rate traffic while operating at 1Gbits/s.

Criteria for Property 1:

- Determinism capability, with user defined values for latency and jitter,
- Maximum data rate.

Property 2: Time Management

Capability of the network system to manage time, i.e. ensuring either a global common clock of all network elements or at least applicative time distribution.

Criteria for Property 2:

- Time synchronisation capability at MAC level,
- Time management algorithms' robustness,
- Interaction with higher layer capabilities (Service Access Points, possibility of synchronization with applications, use of time to trigger actions at application level, etc.).

Before defining the third *property*, let us first explain that we consider a faulty behaviour as either incorrect, lost, out of time constraints or out of traffic contracts.

Property 3: Fault Tolerant Operations

Capability of the network system to operate in a faulty context by preventing faults, by detecting, isolating and recovering from certain faults and by generating failures report/indicators

for higher level fault management in case fault cannot be dealt locally, in a seamless manner.

Criteria for Property 3:

- Error detection capabilities,
- Error reporting capabilities,
- Redundancy capabilities,
- Fault Containment capabilities (ensured by traffic segregation).

Thanks to these three properties, we expect to answer to the following question: *Is the considered network technology capable of providing, at the same time, Mixed QoS, Time Management and Fault Tolerant Operations capabilities for the upgrade of a satellite network ?*

The real challenge is to find a technology that is capable of satisfying all the properties at the same time, forming a *unified network*. This is usually not the case in the current implementations in space where one bus is used for hard real time, highly critical traffic (usually MIL-STD-1553 or CAN) and another bus is used for payload traffic (usually SpaceWire).

B. Motivating Example

Let us consider a motivating example that we will use as support for the overview of the technologies' capabilities.

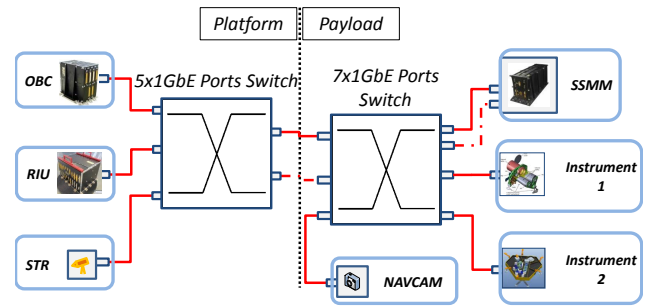

Fig. 1. Motivating network example

This motivating example comes from the use case consolidated after the requirement analysis in [5]. The network system is smaller (fewer end-points) but we consider it to be representative enough to illustrate this work.

The network of Fig. 1 has 7 end-points (ES), 2 $10 \times 1\text{Gbits/s}$ switches (SW), all the devices are 1Gbits/s capable. The physical medium is also capable of conveying a 1 Gbits/s traffic load. The nature of the physical medium (optical or copper) is outside of the scope of this study. The main device in the network is OBC - *On-Board Computer*. It has several applications running concurrently. They send periodic messages to the each end-point of the *platform*. All the communication exchanges in the platform are *transaction-like* i.e. one application sends a request to one device and the device immediately answers to this request. On the *Payload* side, instruments send messages to the SSMM (*Solid State Mass Memory*). Finally, the NAVCAM (*Navigation Camera*) sends periodic messages to the OBC. Both instruments and

NAVCAM do not use transactions to communicate, messages are sent when needed. We characterize the previously introduced exchanges with flows in Table I. This set of flows, denoted \mathbb{F} , is just an extract of all the flows of the complete use case but is still representative of the performance requirements of this network. We let the reader refer to [5] for a more

TABLE I
TRAFFIC CHARACTERISTICS AND REQUIREMENTS

Name	Type	Data Rate	Max. Latency	Max. Jitter
g	OBC to Platform	4bits/s	1ms	1 μ s
h	OBC to Platform	4kbits/s	1ms	10 μ s
i	Platform to OBC	4kbits/s	1ms	NA
j	Instr. to SSMM	65Mbits/s	NA	NA
k	NAVCAM to OBC	250Mbits/s	NA	NA

complete use case description.

Applying the three properties to our use case, we expect that:

- In this network, g , h , i , j and k shall meet their latency and jitter constraints (Property 1).
- There shall be a global common clock (Property 2).
- All frames shall respect their traffic contracts, arrive in their time constraints, no frames shall be lost and frame integrity shall be guaranteed (Property 3).

C. Technologies of interest

Several technologies were previously identified, in internal projects, as candidates for an upgrade of the satellite on-board network, namely Ethernet, ARINC 664, TTEthernet, SpaceFibre and Time Sensitive Networking. They were mainly selected because, at first glance, they could provide a high throughput network with QoS mechanisms available. Other technologies, such as 1553, CAN or SpaceWire are *de facto* discarded from this study since their maximum throughput is too low (less than 1Gbits/s). Before discussing their capabilities w.r.t. the satellite network requirements, let us briefly introduce them.

- **Ethernet:** *Full Duplex Switched Ethernet* or *Ethernet* is an ISO Level 2 (Data Link) technology based mainly on IEEE 802.3 [6] and 802.1Q [7]. In this paper, we name *Ethernet* the technology defined in 802.1Q-2008¹. The network is composed of switches and end-stations that exchange Ethernet frames (format defined in [6]). Ethernet is spread worldwide as it is the standard networking technology used at home and in ISP core networks.
- **ARINC 664:** *ARINC 664* [8] defines an avionic bus with a "deterministic" Ethernet protocol. It is, in particular, used at Boeing, and at Airbus under the name AFDX (Avionics Full DupleX Switched Ethernet). It extends Ethernet(802.1Q-2008) with determinism and fault tolerant capabilities.
- **TT-Ethernet:** *TT-Ethernet* is a 100Mbps/1Gbps scalable networking technology designed for industrial automation and aerospace applications, standardized by SAE under

the reference AS6802 [9]. TTEthernet extends the ARINC 664 standard. It supports mixed quality of service with both synchronous (time-triggered) and asynchronous communications schemes, with the help of a fault-tolerant synchronization strategy.

- **SpaceFibre:** *SpaceFibre* or *ECSS-E-ST-50-11C* [10] is a multi-Gbits/s, on-board network technology for space flight applications, which runs over electrical or fibre-optic cables. It complements the capabilities of SpaceWire [4] by improving the data rate, reducing the cable mass, providing quality of service as well as fault detection, isolation and recovery (FDIR) capabilities.
- **Time Sensitive Networking:** *Time Sensitive Networking* or *TSN* [11] is a technology based on Ethernet developed and promoted by the IEEE TSN Working Group [12] (former AVB - Audio Video Bridging - Working Group [13]) since 2012. It aims at providing many QoS capabilities for conveying traffic of different criticality (such as *Credit Based Shaper - CBS* - or *Asynchronous Traffic Shaping - ATS* -). It has received attention in various industry verticals such as Automotive, Industrial Automation, 5G and Aerospace.

III. SPACEFIBRE

This section discusses the compatibility of SpaceFibre with respect to the three previously introduced properties. The others technologies i.e. Ethernet, ARINC 664, TTEthernet and TSN were discussed in [1].

A. SpaceFibre Medium access

Before discussing the suitability of SpaceFibre (also denoted SpF) with Property 1, 2 and 3, let us introduce our understanding of a SpaceFibre Output Port and how information is exchanged on the physical medium. At Data Link layer, the

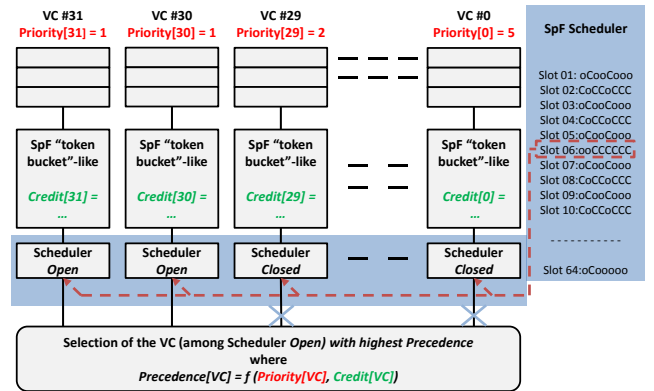

Fig. 2. SpaceFibre Output Port Functional View

basic element of communication is the SpF *data frame*. These frames travel from their emitter to their receiver(s) through SpF *links* and SpF *routing switches*. When a frame arrives in an output port of a switch, it is placed into a VC (or *Virtual Channel*). There are up to 32 VC per output port. These VCs work like FIFOs: the first frame to come in is the first one

¹2014 and 2018 versions are considered beta versions of TSN

to go out. When several VCs have a data frame ready for emission, it is necessary to specify a medium access strategy.

SpF Scheduler

The *SpF Scheduler* offers the possibility of dividing time in 64 time-slots (of configurable fixed duration). In each time-slot, a list of VCs is allowed to try to access the medium. In Fig. 2, the *SpF Scheduler* is represented by the rectangle on the right. In addition, we materialized it on each VC, in a similar manner to TSN Gate Control Lists (cf. Fig. 7 in [14]). When the scheduler block on a VC states *Open*, it means that this VC is authorized to communicate in the time-slot, when the block states *Closed*, the VC is not configured. In the figure, VC #31 and #30 are configured in the represented time-slot.

VC Arbitration & Precedence

Then, in order to arbitrate between VCs authorized to communicate in the same time-slot, SpaceFibre defines *VC Arbitration* i.e. a rule similar to Ethernet *static priority*, based on a value entitled *precedence* per virtual channel at instant t . The precedence of a VC is computed with two values: *VC Priority* and *VC Bandwidth Credit*. The highest precedence VC will be granted access to the medium first. The *VC Arbitration* is represented by the block at the bottom of Fig. 2.

VC Priority

VC Priority is fixed a priori during configuration per VC. In Fig. 2, *VC Priority* is represented at the top, under the name of the VC. For instance, in this representation, VC #31 and #30 have the same and highest priority.

VC Bandwidth Credit

The value of the VC Bandwidth Credit evolves over time: its value is updated for every VC in a port each time a frame is emitted by one of the VC in that port. The bandwidth credit is represented, per VC, in the *SpF Token-bucket*-like block.

SpF Token-Bucket

The evolution of the *VC Bandwidth Credit* is dictated by a mechanism similar to a token-bucket (cf. [15]). This token-bucket like mechanism (let us call it *SpF Token-Bucket*) allows to reserve a portion of the available bandwidth for each VC. Examples of *VC Bandwidth Credit* computation are presented in [16].

Note that this section (including Fig. 2) only represents the user data channel, and ignores broadcast channels and management channels.

B. Property 1

SpaceFiber probably offers the highest data rate among all our technologies of interest. It can reach more than 40Gbit/s [16]. To do so, the SpaceFibre standard offers the possibility to serialize the communication over up to 16 so-called *lanes*

in the same cable (either optical or twisted pairs). This serialization, detailed in [17], is similar to PCI Express serialization over multiple lanes [18].

To be able to provide guaranteed latencies, a system must provide both traffic contracts and bandwidth contract [19]. In a SpaceFibre network, *SpF Token-Bucket* ensures such a traffic limitation. Nevertheless, to get accurate bounds on latencies, a good worst-case model of the *SpF Scheduler* must exist. Since *SpF Scheduling* combines a per VC FIFO strategy, 16 levels of priority and a credit-based algorithm that looks similar to the CBS and ATS, the analysis methods developed for TSN [20] may certainly be adapted for SpaceFibre.

The *SpF Scheduler* is very likely to achieve ultra low jitter ($< 1\mu s$). By configuring the time-slots so that only one VC is allowed to access the medium at any time, one might expect that no traffic from other VC would interfere and induce unwanted jitter due to non-preemption (see [1] for illustration on non-preemption jitter).

However, this last assertion is not always true. In fact, the SpaceFibre standard does not define any guard band mechanism for scheduler. This means that if a VC starts to emit one frame just before the end of its time-slot, that emission will end during the time-slot of the next VC and therefore delaying the next scheduled emission. The maximum induced jitter in this situation is the transmission duration of a frame (256 bytes). If the SpaceFibre network operates at 1Gbit/s, the induced jitter value is $2\mu s$ per hop, leading the ultra low jitter constraints not being satisfied. Nevertheless, if the data rate increases, it will directly reduce the induced jitter value and the jitter constraint is very likely to be satisfied even without guard bands.

To conclude, given the data rate is high enough, SpaceFibre is deemed suitable with respect to property 1.

C. Property 2

Regarding synchronization and time distribution, SpaceFibre offers the possibility to rely on SpaceWire time-codes to distribute time information across the network. To do so, the time-code packet is sent to all network devices with the help of broadcast data frames.

There is no dedicated robustness mechanism specified for this time distribution method. However, the broadcast frames travel in a separate channel (broadcast channel) than user data (virtual channels). As explained in next section, this will provide space and time isolation between broadcast frames (including ones bearing time-codes) and user data. In addition, broadcast messages will also rely on the same fault tolerance mechanisms than data frame (see next section).

Finally, in order to support a network-application synchronization, SpaceFibre Service Access Points at L2 and L3 can forward a broadcast message indication to the upper OSI layers, which they can use to synchronize themselves with network time.

Although the time distribution mechanism lacks robustness, SpaceFibre is deemed almost suitable with respect to Property 2.

D. Property 3

Regarding error detection, the SpaceFibre standard provides three elements. First, a CRC per frame, which allows to detect errors within a frame. Then a sequence number, similar to the one of ARINC 664, allows to detect loss of frames (missing sequence number) or errors in the emitter (several frames with the same sequence number). Finally, the *VC Bandwidth Credit* has a minimum and a maximum value. If the credit reaches any of these bounds, an alert is raised to signify that either the VC uses more bandwidth than reserved or the VC does not get enough bandwidth to meet its traffic contract. The only type of error that SpaceFibre cannot detect is the out of time error e.g. when a frame belonging to a VC that is not scheduled in the current time-slot is emitted.

All the errors detected by SpaceFibre devices can be reported in both a synchronous and an asynchronous ways. When an error is detected, the data link layer triggers an indication that is passed to the upper layer (in particular the application layer), giving a real-time warning on the error. In addition, when an error occurs, a dedicated MIB - *Management Information Base* - counter is updated and can be monitored later on by another entity of fault management. This MIB is really similar to Ethernet MIBs.

SpaceFibre does not offer any redundancy mechanism at Data Link Layer. There is no packet duplication that could travel on disjoint paths whatsoever. However, there is a possibility of having a warm redundancy on the physical medium on a point to point basis. In fact, instead of using the 16 (or less) lanes within a link to increase the link speed, a lane could be in hot standby. In the event of one of the used lane becomes faulty, it would be swapped by the hot standby lane. This would provide a sort of redundancy mechanism at physical level.

Although there is no redundancy, the data link layer in SpaceFibre works in connected mode, meaning that the reception of any frame is acknowledged. In case of erroneous reception, the faulty frame(s) can be retransmitted with the help of a retry mechanism. This behaviour is similar to acknowledgements and retry in TCP protocol [21]. However, this retry mechanism would require further studies as it may affect the performances discussed in Property 1 (e.g. if a frame is retransmitted after the end of the time-slot associated to its VC).

Finally, SpaceFibre proposes solutions to contain the errors detected by a SpaceFibre device. When a frame is received with wrong CRC or wrong sequence number, that frame is deleted therefore preventing it from spreading in the network. That frame can then benefit from the retransmission mechanism. In addition, the token-bucket like mechanism ensures temporal and space isolation between VCs i.e. an out of traffic contract error, as for instance babbling idiot traffic, in one VC will not affect the performances of other VCs. However, to the difference of TSN where out of traffic contract frames are deleted in ingress, out of traffic contract frames in SpaceFibre are not deleted, but reshaped in the next output port so that

it fits the resource reservation of the VC. This can therefore induce unwanted increase in the switching fabric workload, and also potentially lead to buffer overflows.

Even with the lack of proper frame replication mechanism, SpaceFibre is deemed suitable with respect to property 3.

IV. ANALYSIS

Now that the suitability of SpaceFibre with respect to Property 1, 2 and 3 has been discussed, we summarize the output of the previous section in the tables below (cf. II, III, III). These tables also include the summary of the suitability analysis of the other technologies, extracted from [1].

A. Summary

TABLE II
COMPLIANCE TO PROPERTY 1 - MIXED QoS

Criteria	Ethernet	ARINC 664	TTEthernet	TSN	SpF
Data Rate	✓	✓	✓	✓	✓
Latency	✗	✓	✓	✓	✓
Jitter	✗	✗	✓	✓	✓
Suitability	✗	✗	✓	✓	✓

TABLE III
COMPLIANCE TO PROPERTY 2 - TIME MANAGEMENT

Criteria	Ethernet	ARINC 664	TTEthernet	TSN	SpF
At Layer 2	✗	✗	✓	✓	✓
Robustness	✗	✗	✓	✓	✗
Interaction	✗	✗	✗	✓	✓
Suitability	✗	✗	✓	✓	✓

TABLE IV
COMPLIANCE TO PROPERTY 3 - FAULT TOLERANT OPERATIONS

Criteria	Ethernet	ARINC 664	TTEthernet	TSN	SpF
Error Detection	✗	✗	✓	✓	✓
Error Reporting	✓	✓	✓	✓	✓
Redundancy	✗	✓	✓	✓	✓
Fault Containment	✗	✗	✓	✓	✓
Suitability	✗	✗	✓	✓	✓

B. Third-party arguments for the selection of an upgrade candidate

According to the previous analysis, it seems that three technologies would be good candidates for a future unified satellite on-board networks: SpaceFibre, TTEthernet and Time Sensitive Networking. However, apart from properties 1, 2 and 3, several arguments shall also be taken into consideration when choosing between one or another.

First, satellite components have stringent hardware/software constraints, not in certification like in aerospace, but more in radiation, temperature, SEU -*Single Event Upset*- tolerance, etc. This means that the satellite network manufacturer has to either buy end-points and switches designed for space or buy IPs that would be instantiated into space-hardened components. On the one hand, TTEthernet through TTTech,

and SpaceFibre have already been, or are being, implemented into several space projects both in Europe and in the USA and are standardized for space use by ESA in an ECSS standard (*European Cooperation for Space Standardization*). It would hence be possible to obtain space-oriented TTEthernet and SpaceFibre components. On the other hand, TSN, for the past years, has gained increasing interest from the automotive industry and automation industry. The TSN devices that would be available on the market would not completely fulfil the space requirements, especially in term of radiation tolerance. It would however be possible either to buy IPs and instantiate them into space-hardened components or buy the entire COTS and do a radiation tolerance evaluation.

Then, the space community is hoping that the use of COTS components from a widespread technology, shared with other industry verticals would help reducing the overall cost of design, purchase of devices and software development. One drawback of using TTEthernet or SpaceFibre instead of TSN would be that it is only produced and maintained by very limited manufacturers whereas TSN has already dozens of manufacturers working on it. Nevertheless, the products currently advertised by TSN automotive manufacturers might not exactly fit the space needs in terms of performance or environment tolerance and might require further work before being used in space systems; which in the end might lead to an increase of costs. However, the impact on non-recurring cost might be significant enough to make the use of TSN worth. That is why the definition of a profile (like the TSN Automotive Profile but for space) would be a very good starting point to give space and aerospace an identity towards TSN components manufacturers.

On validation and certification side, there is a certain advantage in using TTEthernet or Time Sensitive Networking instead of SpaceFibre. In fact, both TTEthernet and Time Sensitive Networking are based on Ethernet, where numerous research on validation/certification have been lead during the past 15 years. For as much, since these two technologies receive a lot of attention in multiple industrial sectors, they have also been getting more attention from researchers than SpaceFibre. There are now tools available to simulate, configure and validate TTEthernet networks and Time Sensitive Networking tools are getting more mature every day. SpaceFibre has been modelled in OMNET++ simulator [22] but further research will be required in order to validate the real-time behaviour proposed by its medium access strategy.

V. CONCLUSION AND FUTURE WORK

The choice of a future satellite on-board network is clearly not made yet. SpaceFibre, TTEthernet and Time Sensitive Networking are all very good candidates in terms of pure network performance and fault tolerance requirements. Further studies will be required to decide whether a winning technology will emerge or if these three candidates will all be used for different type of missions.

REFERENCES

- [1] P.-J. Chaîne, M. Boyer, C. Pagetti, and F. Wartel, "Comparative study of ethernet technologies for next-generation satellite on-board networks," in *Proc. of the 40th Int. Conference on Data Systems In Aerospace (DASIA)*, 2021.
- [2] Department of Defense – DoD, "MIL-STD-1553B – Aircraft Internal Time Division Command/Response Multiplex Data Bus," Tech. Rep., 1978.
- [3] ISO 11898-2, "Road vehicles – Controller area network (CAN)," Tech. Rep., 2016.
- [4] European Space Agency, "Spacewire-Links, nodes, routers and network," ESA, Tech. Rep. ECSS-E-ST-50-12C, 2018.
- [5] P.-J. Chaîne, M. Boyer, C. Pagetti, and F. Wartel, "Formal specification of satellite on-board networks requirements," 2020, working paper or preprint.
- [6] IEEE, "IEEE Standard for Ethernet," Tech. Rep. IEEE 802.3, 2013-2015-2018.
- [7] —, "IEEE Standard for Local and Metropolitan Area Networks—Bridges and Bridged Networks," Tech. Rep. IEEE 802.1Q, 2008-2014-2018.
- [8] Aeronautical Radio Incorporated, "ARINC Report 664P7-1 Aircraft Data Network, Part 7, Avionics Full-Duplex Switched Ethernet Network," Tech. Rep. ARINC 664P7.
- [9] SAE, "AS6802 - Time-Triggered Ethernet," Tech. Rep. SAE AS6802.
- [10] European Space Agency, "SpaceFibre – Very high-speed serial link," ESA, Tech. Rep. ECSS-E-ST-50-11C, 2019.
- [11] Janos Farkas, "Introduction to 802.1, Focus on the Time-Sensitive Network Task Group," 2018.
- [12] IEEE, "Time Sensitive Networking Task Group," Tech. Rep., 2016.
- [13] IEEE 802.1 AVB Task Group, "IEEE 802.1 Audio/Video Bridging (AVB)," Tech. Rep.
- [14] P.-J. Chaîne, M. Boyer, C. Pagetti, and F. Wartel, "TSN Support for Quality of Service in Space," in *10th European Congress on Embedded Real Time Software and Systems (ERTS 2020)*, Toulouse, France, 2020.
- [15] Guy Pujolles, *Les Reseaux*. Eyrolles, 2018.
- [16] "What is spacefibre ?" , star Dundee - accessed on 10/09/2021.
- [17] A. F. Florit, A. G. Villafranca, and S. Parkes, "SpaceFibre multi-lane: SpaceFibre, long paper," in *2016 International SpaceWire Conference (SpaceWire)*. IEEE, 2016.
- [18] J. Ajanovic, "Pci express 3.0 overview," in *Proceedings of Hot Chip: A Symposium on High Performance Chips*, vol. 69, 2009, p. 143.
- [19] A. Bouillard, L. Jouhet, and E. Thierry, "Tight performance bounds in the worst-case analysis of feed-forward networks," in *Proceedings of the 29th Conference on Computer Communications (INFOCOM 2010)*, march 2010, pp. 1–9.
- [20] L. Maile, K.-S. Hielscher, and R. German, "Network calculus results for tsn: An introduction," in *Proc. of the Information Communication Technologies Conference (ICTC 2020)*. IEEE, 2020, pp. 131–140.
- [21] IETF, "Transmission Control Protocol," Tech. Rep. RFC 675 & RFC 793, 1981.
- [22] Ingeniars.com, "SpaceWire / SpaceFibre Network Model." [Online]. Available: https://www.ingeniars.com/in_product/spacewire-spacefibre-network-model/