



**HAL**  
open science

# Evolution strategies for optimal design of mechanical systems

Laurence Giraud-Moreau, Pascal Lafon

► **To cite this version:**

Laurence Giraud-Moreau, Pascal Lafon. Evolution strategies for optimal design of mechanical systems. 3th World Congress of Structural and Multidisciplinary Optimization (WCSMO-3), May 1999, Buffalo, United States. hal-03620820

**HAL Id: hal-03620820**

**<https://hal.science/hal-03620820v1>**

Submitted on 26 Mar 2022

**HAL** is a multi-disciplinary open access archive for the deposit and dissemination of scientific research documents, whether they are published or not. The documents may come from teaching and research institutions in France or abroad, or from public or private research centers.

L'archive ouverte pluridisciplinaire **HAL**, est destinée au dépôt et à la diffusion de documents scientifiques de niveau recherche, publiés ou non, émanant des établissements d'enseignement et de recherche français ou étrangers, des laboratoires publics ou privés.

# Evolution strategies for optimal design of mechanical systems

L. Moreau-Giraud, P. Lafon

Laboratoire LASMIS, Université de Technologie de Troyes

## 1. Abstract

Mechanical design problems are real-world problems, characterized by a number of inequality constraints, nonlinear equations, mixed discrete-continuous variables and the presence of interdependent discrete parameters whose values are taken from standardized tables. Because of the presence of discrete parameters, these problems are non trivial and they can not be solved by classical gradient-based methods. We propose to use evolution strategies to solve this type of problems. Evolution strategies (ES) are stochastic zero<sup>th</sup> order methods and are well-suited for complex numerical functions. In order to find the best combination of genetic operators with ES for our class of problems, different selection and recombination operators of the literature are tested.

The algorithm is applied to three mechanical design problems. The results are of good reliability and indicate that the method is helpful but the number of evaluations with ES is important.

Then, in order to reduce the computational cost, we propose an hybrid method based on the coupling of ES with the augmented lagrangian method. The comparison between ES alone and the hybrid method indicates that the hybrid method can give results of equivalent reliability but with a number of evaluations divided by two.

## 2. Keywords

Evolution strategies, mechanical design problems, mixed variables, constraints.

## 3. Introduction:

In mechanical design, sizing a mechanical system implies solving a problem of optimization. The latter generally contains nonlinear equations, inequality constraints, mixed discrete-continuous variables and interdependent discrete parameters whose values are taken from standardized tables and which directly depend on the choice of one of the discrete variables. Because of the presence of these interdependent discrete parameters, the gradients can not be calculated in general. Thus, classical gradient-based methods are not suitable for this type of problems. In this paper, we propose to use evolution strategies (ES) to solve these complex mechanical design problems. ESs are members of the class of evolutionary algorithms - heuristic methods based on the principle of natural evolution and guided by the model of Darwin. They are zero<sup>th</sup> order algorithms and they allow to solve problems for which standard gradient-based optimization methods can not be applied. ESs are robust optimization techniques which are well-suited for solving difficult optimization problems but their drawback is the high computational cost. A large number of evaluations must be performed in order to obtain a good result. In order to reduce the computational cost of ES, we propose an hybrid method based on the coupling of ES with a determinist method - the augmented lagrangian method. According to a frequency chosen by the user, the augmented lagrangian algorithm is applied on the continuous variables of each individual in the population of parents, the discrete variables of each individual remain fixed during the application of the augmented lagrangian method.

First, we present ES and its genetic operators. ES is applied to three mechanical design problems. Tests are realized in order to find the best combination of genetic operators with ES for this type of problems. Then, the hybrid method based on the coupling of ES with the augmented lagrangian method is described. The application of the hybrid method to the three mechanical problems and the comparison with ES alone show the efficiency of this method.

## 4. Evolution Strategies :

Evolution strategies mimic the natural process where a population of individuals undergoes transformations of recombination, mutation and selection. By means of randomized processes, the population evolves toward better and better regions of the search space. The neo-Darwinian model of organic evolution is reflected by the algorithm:

```
t:=0
initialization of the population P(t)
evaluation of P(t)
while not terminated do
  P'(t) = recombination (P(t))
  P''(t) = mutation (P'(t))
  evaluation (P''(t))
  P(t+1) = selection (P''(t) ∪ P(t))
  t = t+1
```

### 4.1 Representation

In this algorithm  $P(t)$  is a population of  $\mu$  individuals. In the standard ES (see [1], [2]), each individual is represented by a pair of real-valued vectors  $a = (x_c, \sigma)$ , where  $x_c \in \mathbb{R}^{n_c}$  is a vector composed of continuous variables,  $n_c$  is the number of continuous variables and  $\sigma \in \mathbb{R}_+^{n_c}$  contains standard deviations called strategy parameters. But this representation

can only be applied to continuous variables. In order to deal with mixed discrete-continuous variables, many extensions have been proposed (see [3], [4]). In this paper, we have chosen to use the representation proposed in [3] in which each individual is represented by four vectors  $a = (x_c, x_d, \sigma, p)$  where  $x_d \in \mathbb{R}^{n_d}$  is composed of discrete variables,  $n_d$  is the number of discrete variables,  $p \in [0, 1]^{n_d}$  contains the mutation probabilities.  $\sigma$  and  $p$  are strategy parameters which control the application of mutation to the continuous and discrete variables. As suggested in [3],  $p_i = p, i=1, \dots, n_d$ .

#### 4.2 Evaluation

In order to evaluate each individual, calculating the objective function value is generally used when the problem does not contain any constraint. But as our problems have constraints, it was necessary to choose a method over all the constraint-handling methods proposed in the literature. A good review of the constraint-handling methods with the evolutionary algorithms can be found in [5], [6]. We have chosen a dynamic penalty method in which the penalty coefficient increases during the evolution process every five generations. Penalty methods generally give good results in a reasonable computation time.

#### 4.3 Recombination

The recombination operator generates a new population  $P'(t)$  of  $\lambda$  individuals ( $\lambda > \mu$ ). This mechanism allows a mixing of parental information and passes this information to their descendants. Different recombination mechanisms exist (see [1], [3], [7]). They can all be used either in their local form where two randomly selected parent individuals produce an offspring, or in their global form where one randomly chosen parent is held fixed and the second parent is randomly chosen anew for each single variable. Not only object variables but also strategy parameters are subject to recombination and this strategy operator may be different for continuous variables, discrete variables, standard deviations, and mutation probabilities. As no theoretical basis exists for choosing recombination operators, we decided to test different combinations of recombination operators for the continuous and discrete variables and the strategy parameters. Details of the tests are not presented in this paper.

#### 4.4 Mutation

The mutation introduces innovation into the population. It operates by first mutating the strategy parameters with a multiplicative, logarithmic, normally-distributed process, and then by mutating the continuous variables with a normally-distributed random vector and modifying the discrete variables (see [1], [3]) :

For the continuous variables :

$$\sigma'_i = \sigma_i \cdot \exp(\tau \cdot N(0,1) + \tau \cdot N_i(0,1)) \quad (1)$$

$$x'_{ci} = x_{ci} + \sigma'_i \cdot N_i(0,1) \quad (2)$$

$$\text{where } \tau \propto (\sqrt{2n_c})^{-1} \text{ and } \tau \propto (\sqrt{2\sqrt{n_c}})^{-1}$$

$N(0,1)$  denotes a normally distributed random variable with expectation zero and standard deviation one. The index  $i$  in  $N_i(0,1)$  indicates that the random variable is sampled anew for each value of the index  $i$ .

For the discrete variables :

$$p'_i = \left( 1 + \frac{1 - p_i}{p_i} \cdot \exp(-\gamma \cdot N_i(0,1)) \right)^{-1} \quad (3)$$

$$x'_{di} = \begin{cases} x_{di}, & u_i > p'_i \\ X_i, & u_i < p'_i \end{cases} \quad (4)$$

$$\text{where } \gamma \propto (\sqrt{2\sqrt{n_d}})^{-1}$$

The mutated mutation probability  $p'$  is used to determine whether the discrete variable  $x_{di}$  ( $i \in \{1, \dots, n_d\}$ ) should be modified according to a uniform random variable  $u_i$ .  $X_i$  is a new discrete value chosen randomly in the set of possible discrete values.

The evolution of the strategy parameters which adapt to the topology of the problem has been called "self-adaptation" by Schwefel (see [2]).

#### 4.5 Selection

The selection drives the process toward better regions. Two selection operators exist i.e.  $(\mu, \lambda)$  selection and  $(\mu+\lambda)$  selection. The notation  $(\mu, \lambda)$  indicates that the  $\mu$  best individuals out of the  $\lambda$  offspring individuals are selected as parents. The  $(\mu+\lambda)$  strategy selects the  $\mu$  best individuals from the union of parents and offspring (see [1], [2]). The selection operator is completely deterministic.

## 5. Application and results

### 5.1. Equations of the problems

The previously described algorithm has been applied to three design problems.

#### Problem1:

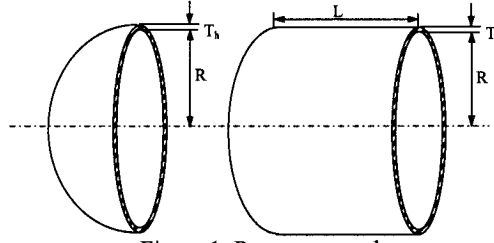

Figure 1: Pressure vessel

The first problem (prob1) is the design of a pressure vessel [8] (see figure 1). The design variables are the dimensions  $T_s$  (the shell thickness),  $T_h$  (the spherical head thickness),  $R$  (the radius of the cylindrical shell), and  $L$  (the length of the shell). The objective is to minimize the total manufacturing cost for the pressure vessel. The optimization problem contains 2 discrete variables ( $T_s$ ,  $T_h$ ), 2 continuous variables ( $R$ ,  $L$ ) and 7 inequality constraints. Its equations are as follows:

Minimize the objective function

$$f(T_s, T_h, R, L) = 0.6224 T_s R L + 1.7781 T_h R^2 + 3.1611 T_s^2 L + 19.84 T_s^2 R \quad (5)$$

Subject to the constraints:

$$g_1(T_s, T_h, R, L) = 0.0193 R - T_s \leq 0 \quad (6)$$

$$g_2(T_s, T_h, R, L) = 0.00954 R - T_h \leq 0 \quad (7)$$

$$g_3(T_s, T_h, R, L) = 1.1 - T_s \leq 0 \quad (8)$$

$$g_4(T_s, T_h, R, L) = 752 * 1728 - \pi R^2 L^2 - 4 \pi R^2 / 3 \leq 0 \quad (9)$$

$$g_5(T_s, T_h, R, L) = 0.6 - T_h \leq 0 \quad (10)$$

$$g_6(T_s, T_h, R, L) = R - 70 \leq 0 \quad (11)$$

$$g_7(T_s, T_h, R, L) = L - 50 \leq 0 \quad (12)$$

#### Problem2:

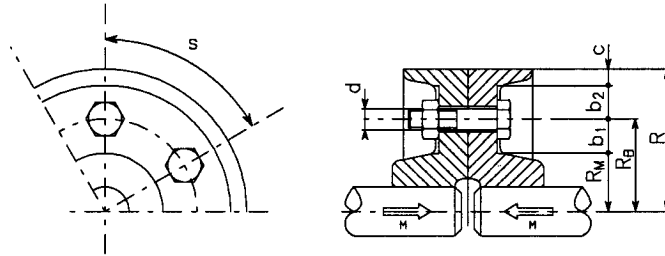

Figure 2: A coupling with bolted rim

The second problem (prob2) is a coupling with bolted rim [9] (see figure 2). The formulated optimization problem contains one discrete variable, one integer variable, 3 inequality constraints and 5 discrete bolt parameters. A torque is transmitted by adhesion using  $N$  bolts of diameter  $d$  placed at radius  $R_B$ . The problem is to minimize a multiobjective function: the aim is to find the coupling with the smallest diameter, the smallest number of bolts and the lowest torque. In this study we assume that the restrained linkage between the shaft and the coupling was chosen. The shape of the rim shape is fixed by some manufacturing conditions. The formulated optimization problem contains one discrete variable ( $d$ ), one integer variable ( $N$ ), two continuous variables ( $R_B$ ,  $M$ ), 11 inequality constraints and 5 discrete bolt parameters ( $\phi_i(d)$ ,  $i=1, \dots, 5$ ). The equations of the problem are as follows:

Minimize the objective function:

$$f(d, N, R_B, M) = \beta_1 \left( \frac{N}{8} \right) + \beta_2 \left( \frac{R_B + \Phi_4(d) + 5}{50} \right) + \beta_3 \left( \frac{M}{4000} \right) \quad (13)$$

Subject to the constraints:

$$g_1(d, N, R_B, M) = \frac{1.5M}{N \cdot R_B \cdot K(d)} - 1 \quad (14)$$

$$g_2(d, N, R_B, M) = 1 - \frac{2\pi R_B}{\Phi_5(d) \cdot N} \quad (15)$$

$$g_3(d, N, R_B, M) = 1 - \frac{R_B}{\Phi_4(d) + 50} \quad (16)$$

$$g_4(d, N, R_B, M) = N - 100 \quad (17)$$

$$g_5(d, N, R_B, M) = R_B - 1000.0 \quad (18)$$

$$g_6(d, N, R_B, M) = 8 - N \quad (19)$$

$$g_7(d, N, R_B, M) = 50 - R_B \quad (20)$$

$$g_8(d, N, R_B, M) = M - 1000 \quad (21)$$

$$g_9(d, N, R_B, M) = 4000 - M \quad (22)$$

$$g_{10}(d, N, R_B, M) = d - 24 \quad (23)$$

$$g_{11}(d, N, R_B, M) = 6 - d \quad (24)$$

$$\text{with } K(d) = \frac{84.645\pi(\Phi_1(d))^2}{4\sqrt{1 + 3\left(\frac{0.16\Phi_3(d) + 0.087\Phi_2(d)}{\Phi_1(d)}\right)^2}}$$

### Problem3:

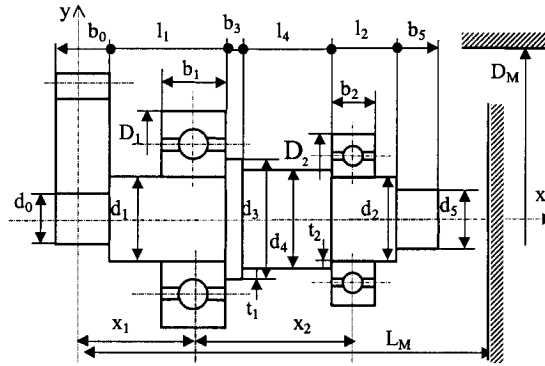

Figure 3 : Ball bearing pivot link

The last problem (prob3) is a ball bearing pivot link (see figure 3). The aim is to find the lengths  $x_1$ ,  $x_2$  and the two ball bearings  $R_1$  and  $R_2$  in order to minimize the weight of the assembly composed of a shaft and two ball bearings. These ball bearings are chosen from a standardized table of prefabricated sizes. The formulated problem contains 4 variables, 2 continuous ( $x_1$ ,  $x_2$ ), 2 integer ( $R_1$ ,  $R_2$ ) variables, 12 discrete parameters and 10 inequality constraints.  $R_1$  and  $R_2$  represent the choice of the two ball bearings. In order to solve this problem with ES, we numbered the ball bearings, having a diameter from 30 to 50, from 1 to 32, in the same order as the standardized table.  $R_1$  and  $R_2$  can take values between 1 and 32. The parameters of the 2 ball bearings are  $(C_1, d_1, D_1, b_1, da_1, m_1)$  and  $(C_2, d_2, D_2, b_2, da_2, m_2)$  respectively, depending on the choice of the ball bearing.  $m_1$  and  $m_2$  represent the mass of the two ball bearings. Thus, we have the following formulation, with  $X = \{R_1, R_2, x_1, x_2\}$  and the data:  $\{b_0, b_3, e_1, e_4, e_2, D_M, L_M, b_5, d_0, \rho\}$ :

Minimize the objective function:

$$f(X) = \pi\rho(x_1d_1^2 + 0.5(b_0d_1^2 - b_2da_2^2 + b_1d_1^2) + b_3da_1^2 + x_2da_2^2 - b_3da_2^2 + b_2d_2^2 + d_2^2)/4 + m_1 + m_2 \quad (25)$$

Subject to the constraints:

$$g_1(X) = 0.5 b_1 - x_1 + (0.5b_0 + e_1) \leq 0 \quad (26)$$

$$g_2(X) = 29216 (1 + x_1/x_2) - C_1 \leq 0 \quad (27)$$

$$g_3(X) = 29216 (x_1/x_2) - C_2 \leq 0 \quad (28)$$

$$g_4(X) = (615.51x_1 + 3930)^{1/3} - d_1 \leq 0 \quad (29)$$

$$g_5(X) = 0.5 b_1 + 0.5 b_2 - x_2 + (e_4 + b_3) \leq 0 \quad (30)$$

$$g_6(X) = x_2 + x_1 + 0.5b_2 - 177 \leq 0 \quad (31)$$

$$g_7(X) = D_2 - D_1 \leq 0 \quad (32)$$

$$g_8(X) = d_0 - d_1 \leq 0 \quad (33)$$

$$g_9(X) = d_5 - d_2 \leq 0 \quad (34)$$

$$g_{10}(X) = D_1 - 100 \leq 0 \quad (35)$$

## 5.2. Results

As seen in §4, a number of selection and recombination operators exist in the literature. As no theoretical basis exist for the choice of these operators for our class of problems, we tested several operators (2 selection operators and 48 combinations of recombination operators) in order to find the best combination of operators for each design problems. The operators which have given the best reliability are global discrete recombination ( $X_i^S$  or  $X_i^{Ti}$ ) for the discrete variables and global intermediate recombination ( $(X_i^S + 0.5(X_i^{Ti} - X_i^S))$ ) for the probability of mutation. The indices S and T denote two parents selected at random and  $u \in [0, 1]$  is an uniform random variable. The index  $i$  in  $T_i$  or  $u_i$  indicates that T or u are sampled anew for each value of  $i$ . For continuous variables and strategy parameters, the best operators are for the simplest of our problems (prob1) respectively the local discrete ( $X_i^S$  or  $X_i^T$ ) and the global intermediate recombination. For the other two problems, they are a global extended generalized recombination for both operators ( $X_i^S + u_i(X_i^{Ti} - X_i^S)$ ,  $u_i \in [0.5, 1.5]$ ). For the selection, the  $(\mu + \lambda)$  strategy has always outperformed the standard  $(\mu, \lambda)$  strategy for our problems. We must notice that these selection and recombination operators are different from the standard operators of ES.

Results of ES for each problem with the best combination of operators are presented in table 1. We give the average error for 15 runs with regard to the theoretical optimum and the error corresponding to the best run. In this application, (15+100)ES was used and 15 runs were performed for each problem in order to obtain statistically significant data.

	Prob1	Prob2	Prob3
best error (%)	0	0	0
average error for 15 runs (%)	1.05	0.77	3.28
number of evaluations	75225	75225	75225

Table 1: Results with ES

As we can see, the theoretical global optimum was always identified by ES and the average error is always smaller than 4 %. ES has enabled us to obtain results of good reliability for our difficult problems of optimal design but the price to pay is the high computational cost.

## 6. Hybrid method

ES has been coupled with the augmented lagrangian method. One of the important characteristics of the optimal design problems is that they have to be solved for a fixed set of data values. When these values change, the topology of the solution set is modified and this set can change from a convex to a non convex set. The only mathematical programming methods that do not require the assumption of convexity to establish a global property of convergence are dual methods [10]. The augmented lagrangian algorithm in its principle is close to a classic algorithm based on dual method. It consists in a minimization sequence with respect to  $x$  of the augmented lagrangian function alternated with an update of dual variables  $\lambda$ . The penalty parameter  $r$  is increased after each update of the dual variables. The augmented lagrangian function [11] is an association of a classic dual function and a quadratic penalty function. Its expression is as follows:

$$L(x, \lambda, r) = f(x) + \sum_{j=1}^m (\lambda_j \psi_j(x) + r \cdot \psi_j^2(x)) + \sum_{k=1}^l (\lambda_k g_k(x) + r \cdot g_k^2(x)) \quad (36)$$

$$\text{with: } \psi_j(x) = \text{Max} \left\{ g_j(x), -\frac{\lambda_j}{2r} \right\}$$

$m$ : number of inequality constraints and  $l$ : number of equality constraints

According to a frequency chosen by the user, the augmented lagrangian algorithm is applied on the continuous variables of each individual in the population of parents, the discrete variables of each individual remain fixed during the application of the augmented lagrangian method. By calling this determinist method, we can obtain for each individual the optimal continuous variables corresponding to the discrete variables of this individual, with few generations. This allows to accelerate the convergence. This acceleration is illustrated in figure 4. This figure presents the evolution of the average objective function for 15 runs over the number of generations in problem 2 for ES alone and the hybrid method when the augmented lagrangian algorithm is applied every five generations. We can see that the call of the augmented lagrangian method has allowed to accelerate the convergence significantly.

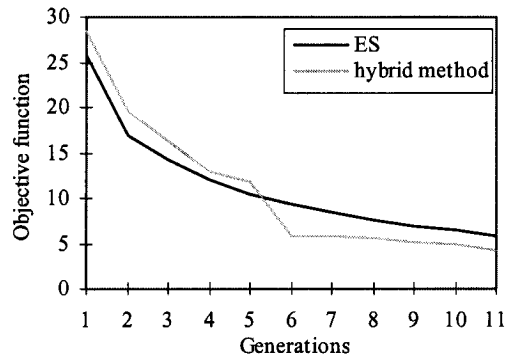

Figure 4: Comparison ES alone and the hybrid method

Finally the best compromise between reliability and computational cost was obtained with a two-stage procedure: ES is used first during a fixed number of generations; then the augmented Lagrangian method is applied on the continuous variables of the individuals of the final population. Results of this hybrid method for the three mechanical design problems are presented in table 2.

	Prob1	Prob2	Prob3
best error (%)	0	0	0
average error for 15 runs (%)	1.7	0.64	3.75
number of evaluations	32693	32330	30801

Table 2 : Results with the hybrid method

The reliability of these results is equivalent to that given by ES alone but the number of evaluations is twice smaller. This hybrid method using ES to locate local minima and the augmented lagrangian method to accelerate local convergence has allowed to reduce significantly the computational cost with regard to our mechanical design problems.

## 7. Conclusion

ESs are interesting tools to solve complex mechanical design problems, for which classical gradient-based methods can not be used. For our three design problems, we have obtained results of good reliability. One of the advantages of evolutionary algorithms is that they do not require any derivative information. Moreover they can provide a number of potential solutions, which can leave a choice to the designer. But the inconvenient is the high computational cost. In order to reduce the computational cost, we have proposed a coupling "in series" of ES with a determinist method. The number of evaluations was reduced significantly. Those results are encouraging. Our next research should be on a coupling "in parallel" of ES and determinist methods in order to improve the algorithm.

## 7. References

- [1] T. Bäck (1996). *Evolutionary algorithms in theory and practice*, Oxford University Press, New York.
- [2] H.P. Schwefel (1981). *Numerical optimization of computer models*. Chichester: Wiley.
- [3] T. Bäck, M. Schütz (1995). Evolution strategies for mixed-integer optimization of optical multilayer systems. *Proceedings of the Fourth Annual Conference on Evolutionary Programming*, J.R. McDonnell, R.G. Reynolds, and D.B. Fogel, editors, MIT Press, Cambridge, MA, 33-51.
- [4] M. Herdy (1991). Application of the evolution strategy to discrete optimization problems. *Proceedings of the first international conference on parallel problem solving from nature (PPSN)*, vol. 496, Lecture note in Computer Science, Springer-Verlag.
- [5] Z. Michalewicz, M. Schoenauer (1996). Evolutionary algorithms for constrained parameter optimization problems. *Evolutionary Computation*, vol. 4, 1-32.
- [6] Z. Michalewicz (1996). *Genetic Algorithms + Data Structures = Evolution Programs*. Springer, Berlin.
- [7] J.R. Mac Donnell, D.E. Waagen (1995). An empirical study of recombination in evolutionary search. *Proceedings of the Fourth Annual Conference on Evolutionary programming*. J.R. Mac Donnell, R.G. Reynolds and D.B. Fogel (Eds), 465-478.
- [8] S-J. Wu, P.T. Chow (1994). Genetic Algorithms for solving mixed-discrete optimization problems. *The Franklin Institute*, vol. 331B, no. 4, 381-401.
- [9] P. Lafon (1994). *Conception optimale de systèmes mécaniques: Optimisation en variables mixtes*. Thèse 3ème cycle, n° d'ordre 273, Institut National des Sciences Appliquées de Toulouse.
- [10] M. Minoux. *Programmation Mathématique: Théorie et Algorithmes*. Tome1 et 2, Edition DUNOD 1983
- [11] R.T. Rockafellar (1974). Augmented lagrange multiplier functions and duality in nonconvex programmings. *SIAM Journal Control*, vol. 12, 268-285.