



**HAL**  
open science

## Evaluation of an intensified continuous heat-exchanger reactor for inherently safer characteristics

Wassila Benaissa, Nadine Gabas, Michel Cabassud, Douglas Carson, Sébastien Elgue, Michel Demissy

► **To cite this version:**

Wassila Benaissa, Nadine Gabas, Michel Cabassud, Douglas Carson, Sébastien Elgue, et al.. Evaluation of an intensified continuous heat-exchanger reactor for inherently safer characteristics. *Journal of Loss Prevention in the Process Industries*, 2008, 2 (5), pp.528-536. 10.1016/j.jlp.2008.04.004 . hal-03580578

**HAL Id: hal-03580578**

**<https://hal.science/hal-03580578v1>**

Submitted on 18 Feb 2022

**HAL** is a multi-disciplinary open access archive for the deposit and dissemination of scientific research documents, whether they are published or not. The documents may come from teaching and research institutions in France or abroad, or from public or private research centers.

L'archive ouverte pluridisciplinaire **HAL**, est destinée au dépôt et à la diffusion de documents scientifiques de niveau recherche, publiés ou non, émanant des établissements d'enseignement et de recherche français ou étrangers, des laboratoires publics ou privés.

# Evaluation of an intensified continuous heat-exchanger reactor for inherently safer characteristics

Wassila Benaïssa<sup>b,\*</sup>, Nadine Gabas<sup>a</sup>, Michel Cabassud<sup>a</sup>, Douglas Carson<sup>b</sup>, Sébastien Elgue<sup>a</sup>, Michel Demissy<sup>b</sup>

<sup>a</sup> Laboratoire de Génie Chimique, UMR 5503 CNRS-INPT-UPS, BP 1301, 5 rue Paulin Talabot, 31106 Toulouse, Cedex 1, France

<sup>b</sup> INERIS (Institut National de l'Environnement Industriel et des Risques), Parc Alata, BP 2, 60550 Verneuil-en-Halatte, France

---

## A B S T R A C T

The present paper deals with the establishment of a new methodology in order to evaluate the inherently safer characteristics of a continuous intensified reactor in the case of an exothermic reaction. The transposition of the propionic anhydride esterification by 2-butanol into a new prototype of "heat-exchanger/reactor", called open plate reactor (OPR), designed by Alfa Laval Vicarb has been chosen as a case study. Previous studies have shown that this exothermic reaction is relatively simple to carry out in a homogeneous liquid phase, and a kinetic model is available. A dedicated software model is then used not only to assess the feasibility of the reaction in the "heat-exchanger/reactor" but also to estimate the temperature and concentration profiles during synthesis and to determine optimal operating conditions for safe control. Afterwards the reaction was performed in the reactor. Good agreement between experimental results and the simulation validates the model to describe the behavior of the process during standard runs.

A hazard and operability study (HAZOP) was then applied to the intensified process in order to identify the potential hazards and to provide a number of runaway scenarios. Three of them are highlighted as the most dangerous: no utility flow, no reactant flows, both stop at the same time. The behavior of the process is simulated following the stoppage of both the process and utility fluid. The consequence on the evolution of temperature profiles is then estimated for a different hypothesis taking into account the thermal inertia of the OPR. This approach reveals an intrinsically safer behavior of the OPR.

---

### Keywords:

Process safety  
Intensification  
Simulation  
Heat-exchanger/reactor  
Runaway scenario  
Inherently safer

---

## 1. Introduction

Most of the processes involved in the specialty chemical industries are batch or semi-batch. They are particularly convenient because of their flexibility and make it possible to produce a large range of different chemicals within the same apparatus. Indeed, fine chemicals industry is often confronted with the rapid change of the customer's demand and has to be able to switch quickly from one reaction to another. Through time these reactors were improved by numerous specific tools that were developed in order not only to increase their efficiency, optimize yield and selectivity (Zhang & Smith, 2004) but also to decrease the environmental impact by reducing the use of solvent (Elgue, Prat, Cabassud, & Cézerac, 2006). However, these kind of reactors

present an important technological limit: temperature control is not always sufficient and numerous case histories have demonstrated that most of the thermally initiated accidents took place in batch processes (Gustin, 2002). When an exothermic reaction is carried out, unpredicted deviations can lead to dangerous situations: cooling failure as well as inappropriate stirring, unknown side reactions and wrong reactant dosing could initiate a runaway. From the 80s, safety has become a priority in the design and development of chemical processes (Lees, 2001). Large research effort contributed to the improvement of new safety tools and methodologies: for instance several calorimetric devices have been invented for the fast determination of thermo-kinetic behavior of the reactions involved (Maria & Heinzle, 1998). But also, systematic methods are now available to anticipate the potential responses of batch processes in the case of thermal deviations and to include appropriate external safety barriers in the overall facility (Stoessel, 1993).

But nowadays, the chemical industry has to go further and deal with new challenges. In addition to producing more and faster,

---

\* Corresponding author. Tel.: +33 3 44 55 62 29; fax: +33 3 44 55 65 65.

E-mail addresses: Wassila.benaïssa@ineris.fr (W. Benaïssa), Nadine.Gabas@ensiacet.fr (N. Gabas).

Nomenclature		$\Delta T_{ad}$	adiabatic temperature rise ( $^{\circ}\text{C}$ )
$C$	concentration ( $\text{mol L}^{-1}$ )	$\Phi$	adiabatic coefficient
$C_{p_r}$	heat capacity of the reaction mixture ( $\text{J g}^{-1} \text{K}^{-1}$ )	<i>Subscript</i>	
$E_a$	activation energy ( $\text{J mol}^{-1}$ )	<i>2but</i>	2-butanol
$H_r$	acidity function	<i>acp</i>	propionic acid
$k_0$	frequency factor	<i>anhp</i>	propionic anhydride
$k$	reaction rate constant	<i>cat<sub>1</sub></i>	catalyst 1
$m$	mass (kg)	<i>cat<sub>2</sub></i>	catalyst 2
$m_r$	reaction mixture mass (kg)	$k$	cell index
$p$	kinetic parameters	<i>Abbreviation</i>	
$R$	gas constant ( $\text{J K}^{-1} \text{mol}^{-1}$ )	<i>ICI</i>	imperial chemical industries
$r$	reaction rate ( $\text{mol L}^{-1} \text{s}^{-1}$ )	<i>MTSR</i>	maximum temperature of the synthesis reaction in the cell number $k$ ( $^{\circ}\text{C}$ )
$T_r$	temperature of the reaction mixture (K)	<i>PC</i>	process chamber
$T_0$	temperature of the reaction mixture before deviation (K)	<i>TP</i>	transition plates
$t$	time (s)	<i>SP</i>	sandwich plates
$V$	volume (L)	<i>TE</i>	thermal environment
$X$	steady-state conversion reached during normal operation	<i>UF</i>	utility fluid
<i>Greek</i>			
$\Delta H_r$	heat of reaction ( $\text{J mol}^{-1}$ )		

inherently safer and cleaner production must be performed. Thus, alternatives have emerged to dramatically improve chemical processes. Green chemistry is certainly one of the most relevant examples. During the previous decades, new perspectives have emerged with process intensification. This movement started a new way of thinking concerning the evolution and the future design of production units in the chemical industry: the challenge is to decrease their size but increase their efficiency (Stankiewicz & Moulijn, 2002). In this field, process intensification can be considered as a method that allows one to prevent and reduce risks related to major industrial accidents. To reach this objective, one solution is to create new types of equipments with innovative characteristics and significantly higher performances in order to attain better heat transfer and thus safer conditions compared to traditional batch or semi-batch operations. These performances can be attained by modifying the operating conditions by employing higher concentrations and using less solvent and reaction volumes. Focusing on the reaction zone, some successful projects have already demonstrated that it was possible to conceive original reactors, miniaturized, multifunctional and/or continuous. For instance, ICI improved dramatically one of their production plants by combining the qualities of a heat exchanger and a chemical reactor in the same apparatus (Phillips, Lausche, & Peerhossaini, 1997). These encouraging results illustrated how the chemistry industry could move in new directions and how engineering science could be used to replace traditional processes with new promising reactors smaller, better and safer. Since the initial applications, process intensification did not stop growing and today we can find numerous studies on innovative pilots (Jachuk, 2002; Stankiewicz, 2003). New prototypes of "heat-exchanger/reactors" are a good illustration: built like a plate heat-exchanger, internal plates are designed in order to carry out chemical synthesis. But because of these new concepts of reactor design being less familiar than traditional ones, research work is necessary not only to assess their feasibility and potentialities but also to evaluate their efficiency and intrinsic characteristics.

The aim of this work is to evaluate the inherently safer characteristics of an intensified continuous heat-exchanger/

reactor. To meet this goal, a prototype of "heat-exchanger reactor", provided by Alfa Laval Vicarb, called open plate reactor (OPR), was considered to carry out the esterification of propionic anhydride by 2-butanol. Firstly, the feasibility of the transposition of this reaction into the OPR was experimentally validated (Benaissa, 2006). Later, risk assessment of the process was performed, which highlights accidental scenarios. One major scenario is the stoppage of both process and utility flows. Therefore, this work focuses on the thermal consequences of flows failure considering the physical characteristics of the different elements of the OPR. Moreover, a comparison between the kinetics and the heat-transfer characteristics times allows discriminating the different hypothesis taken into account to estimate temperature variations after failure.

## 2. Case study: propionic anhydride esterification

Esterification of propionic anhydride by 2-butanol leads to butyl propionate and propionic acid (Fig. 1). This synthesis was first studied by Snee, Barcons, Hernandez, and Zaldivar (1992) in order to elaborate a standard method for determining thermodynamic parameters using numerous adiabatic and isothermal calorimetric devices. The system has later been chosen in many studies relating to the assessment of the chemical risk and specifically to build optimal safety procedures for batch and semi-batch reactors (Feliu, Iban, Alos, & Macias-Hernandez, 2003; Ubrich, Srinivasan, Lerena, Bonvin, & Stoessel, 1999). This reaction constitutes a relevant case study for the transposition from batch to continuous process: it is relatively simple to carry out in a homogeneous liquid phase, is exothermic, and a kinetic model is available.

The synthesis is exothermic: Galvan, Zaldivar, Hernandez, and Molga (1996) found a value of  $\Delta H_r = -62.99 \text{ kJ mol}^{-1}$  and Ubrich, Srinivasan, Lerena, Bonvin, and Stoessel (2001) proposed  $\Delta H_r = -62.5 \text{ kJ mol}^{-1}$ . Both authors agree that there is no decomposition reaction.

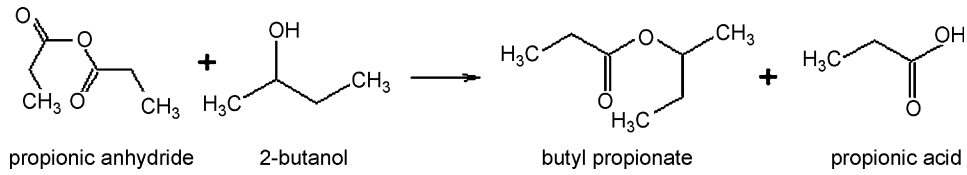

Fig. 1. Reaction scheme for the esterification of propionic anhydride by 2-butanol.

## 2.1. Kinetics model

According to Snee et al. (1992), the reaction rate is a function of the catalyst: without the catalyst the reaction is second-order but has a kind of autocatalytic behavior when sulfuric acid is present in the reaction mixture.

When the reaction is performed with no strong acid as catalyst, the reaction is slow and follows second-order kinetics, first order in each reactant (Galvan et al., 1996):

$$r = k_0 C_{anhp} C_{2but} \quad (1)$$

with

$$k_1 = 5.36 \times 10^7 \exp\left(-\frac{80478}{RT_r}\right) \quad (2)$$

In the presence of sulfuric acid, Zaldivar, Hernandez, Molga, Galvan, and Panetsos (1993) made the following remarks:

- The reaction rate seems to be proportional to the acid concentration.
- The reaction rate increases with propionic acid concentration, causing a kind of autocatalytic behavior (Eqs. (3) and (4)).
- After having reached a certain concentration, propionic acid no longer influences the reaction rate.

Since the various theoretical reaction pathways are complex, an empirical model was devised assuming the existence of two catalysts ( $cat_1$ ,  $cat_2$ ) (Dhanuka, Malshe, & Chandala, 1977). The transformation of the initial catalyst was developed by taking into account the acidity function (Eq. (5)).

Reaction 1: propionic anhydride+2-butanol→butyl propionate+propionic acid.

Reaction 2: catalyst 1→catalyst 2.

The reaction rate of the main reaction can be written as

$$r_1 = (k_1 + k_2 C_{cat_1}) C_{anhp} C_{2but} + k_3 C_{cat_2} C_{anhp} \quad (3)$$

The reaction rate due to the formation of the second catalyst is also taken into account:

$$r_{cat} = k_4 10^{-Hr} C_{cat_1} C_{2but} \quad (4)$$

Lastly, the expression of the acidity function is

$$Hr = -(p_1 C_{cat_1} + p_2 C_{acp}) \left( p_3 + \frac{p_4}{T_r} \right) \quad (5)$$

Reaction rate constants follow Arrhenius law:

$$k_i = k_{0i} \exp\left(-\frac{E_{ai}}{RT_r}\right) \quad (6)$$

The kinetic parameters are summarized in Table 1.

Table 1  
Kinetic parameters equations

Subscript $i$	$k_{0i}$	$E_{ai}$ (J mol <sup>-1</sup> )	Parameter $p_i$
1	$5.36178 \times 10^{7a}$	80,478.64	$2.002 \times 10^{-1}$
2	$2.8074 \times 10^{10b}$	79,159.5	$3.205 \times 10^{-2}$
3	$3.9480 \times 10^{10a}$	69,974.6	-21.3754
4	$1.4031 \times 10^{8a}$	76,617.2	12706

<sup>a</sup> L mol<sup>-1</sup> s<sup>-1</sup>.

<sup>b</sup> L<sup>2</sup> mol<sup>-2</sup> s<sup>-1</sup>.

## 3. Heat-exchanger reactor OPR

### 3.1. Pilot plant description

The reaction unit used in the process was designed by Alfa Laval Vicarb and built like a multi-plates heat exchanger divided into three sections (Prat, Devatine, Cognet, Cabassud, & Gourdon, 2005) (Fig. 2). Each section is made up of a reaction plate where the reaction mixture flows, surrounded by two cooling plates containing the utility fluid. The reactants and catalyst are stored separately and put in contact only at the entrance at the first reaction plate. It appears particularly well-suited to process intensification, as it is possible to attain better heat transfer since the heat transfer surface/reaction volume ratio is increased and the utility flow much higher than the process one: about 3000 Lh<sup>-1</sup> compared to the reactants flow-rate of 50 Lh<sup>-1</sup>. Under these conditions, previous studies have shown that the OPR can be considered as a plug flow reactor. The total pilot capacity is 1.5 L of reaction mixture (0.5 L per section). This new concept of "heat-exchanger/reactor" has been chosen as a typical example of a small continuous reactor. The successive plates of one block of the reactor can be represented as shown in Fig. 3: inside the reactive plate (RP), the environment of the reaction mixture is composed of PolyetherEtherKetone (PEEK). The utility fluid (UF) flows between two stainless steel plates: the sandwich plates (SP) and the transition plates (TP).

### 3.2. OPR modeling

A specific computer simulation program has been written in parallel to the development of the reactor in order to predict the "heat-exchanger/reactor" behavior according to the operating conditions (Elgue et al., 2006). It integrates a precise description of the OPR geometry and models the hydrodynamic reaction phenomena as well as heat transfer in the device (Benaissa et al., 2008). As the OPR is a continuous plug-flow reactor, process flow modeling is based on the classical representation of a sequence of perfectly stirred tank reactors (called cells) (Neuman, 2002). In the case of a pilot plant composed of three blocks, experimental distribution of residence times, which allows flow analysis, showed that the reaction line could be described by a series of 91 cells which corresponds to the actual number of rows (Fig. 4).

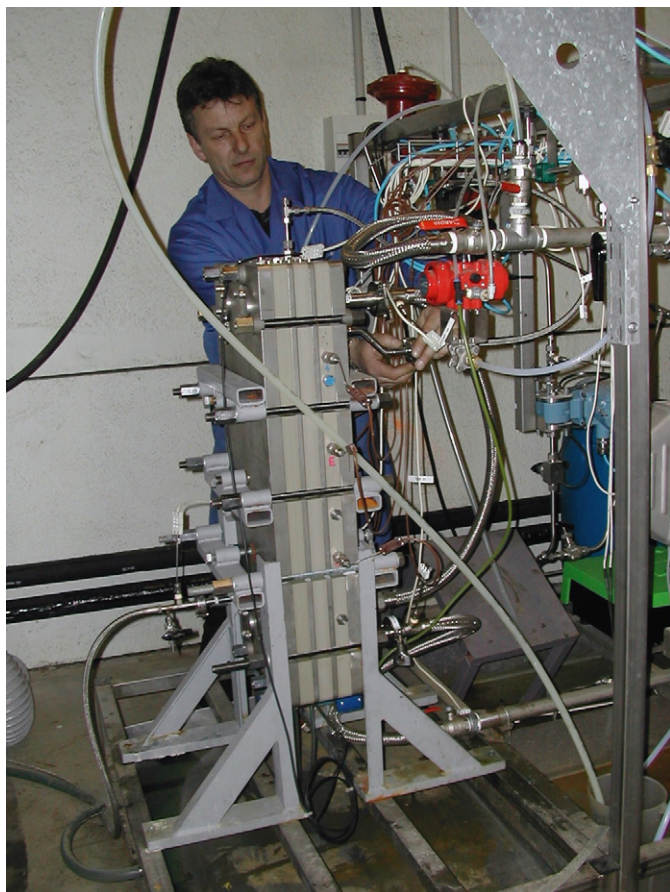

Fig. 2. View of the instrumented "heat-exchanger/reactor" OPR.

In this configuration, the state and the evolution of a cell solely depend on the phenomena taking place inside (reaction and heat transfer) and on the inlet streams, which are generally the outlet streams of the previous cell (Fig. 5). In the simulation framework, the model is then based on balance equations (mass and energy) and on constraints equations for each cell. The software takes into account the specific geometry of the intensified reactor and provides the temperature profiles of the cooling fluid as well as the temperature and conversion profiles along the reaction line.

The use of this data-processing tool makes it possible to assess the feasibility of carrying out the esterification in the OPR. The main parameters to be modified are the initial sulfuric acid concentration, inlet temperature and cooling fluid flow-rate. It is then possible to determine the operating conditions in terms of molar conversion while maintaining proper heat transfer and an overall temperature lower than 100 °C in order to avoid the boiling point of the reaction mixture (Benaissa, 2006). Preliminary reaction tests carried out with the OPR have been used to validate the simulation framework. Fig. 6 shows the results of an experiment carried out with the following conditions: utility temperature (70 °C), utility flow rate (3 m<sup>3</sup> h<sup>-1</sup>), process flow rate (stoichiometric ratio) (50 Lh<sup>-1</sup>) and sulfuric acid mass fraction (0.8% expressed as a percentage of the weight of 2-butanol), after the stationary state has been reached. The temperature profiles obtained with the framework are compared with the data obtained by the sensors placed along the reaction line and the utility line of the pilot. This figure shows a good agreement between the measurements carried out with the thermocouples and the simulation. Thus, the complete model was validated and

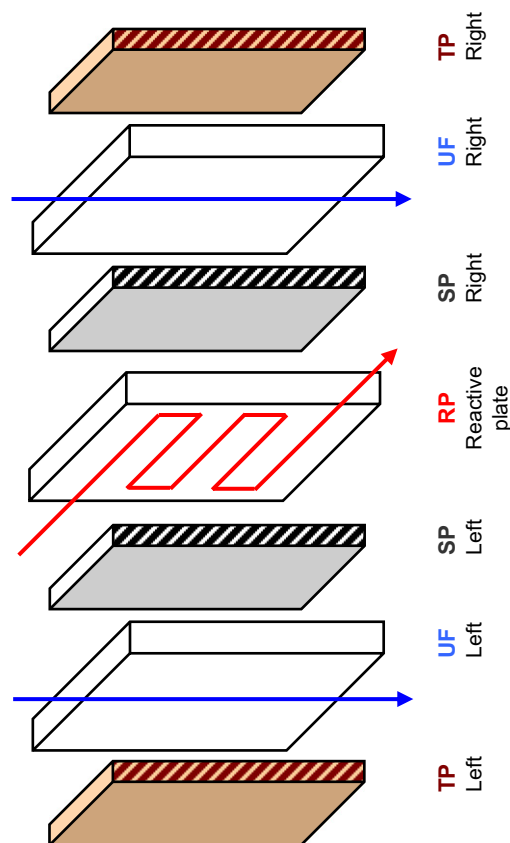

Fig. 3. Successive plates contained in a block of the "heat-exchanger/reactor" OPR.

the feasibility of the reaction case study carried out in the OPR was demonstrated.

#### 4. Risk assessment: hazard and operability (HAZOP) method

In order to achieve a risk assessment on the overall unit studied, the process flow diagram had to be first designed as complete and as clear as possible. The schematic representation used for this study, including all materials, is presented in Fig. 7. Four main flow lines were designed: one for feeding each reactant (reactant number 1 and number 2), one for products collection and one for the utility fluid circulation. This utility fluid line is a thermal closed loop filled by glycol water. The inlet temperature (TR10) of this fluid is controlled via two heat exchangers connected to two secondary circuits: one ensuring heating, the other cooling.

Each raw material is stored in two different tanks. The feed lines ensure reactant introduction in the reactor at a given temperature: the main line connected to the first storage tank has a nominal operating point of 30 Lh<sup>-1</sup>, whereas the secondary line operates at 20 Lh<sup>-1</sup>. 2-Butanol and sulfuric acid are mixed with propionic anhydride after their introduction in the reactor. The products are then collected at the outlet of the third block and sent to another storage tank. Two other storage tanks contain pure water in order to clean and purge the pipes before and after the experiment. The utility line was designed to be flexible: the ethylene glycol can be heated by a boiler or cooled down by an external water circulation. The operating inlet temperature is controlled at 70 °C. Parameters such as temperature, pressure and flow rate are measured along the fluid lines with specific devices and nine thermocouples located in the reactive plates.

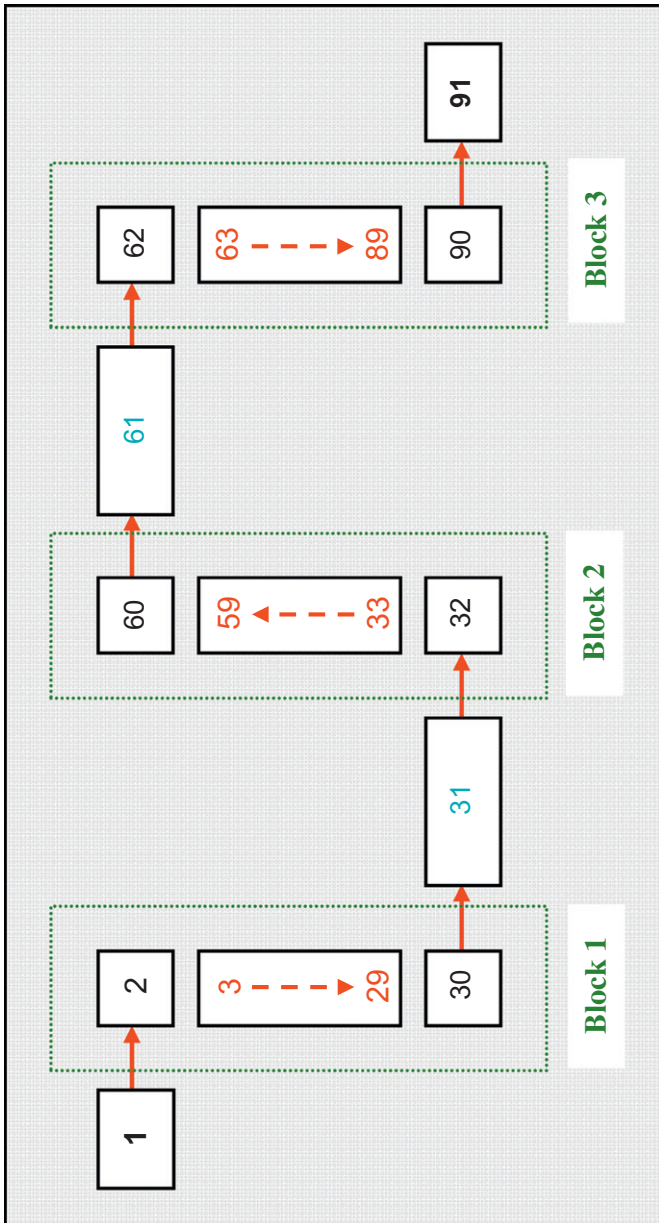

Fig. 4. Reaction line modeling by a series of 91 cells.

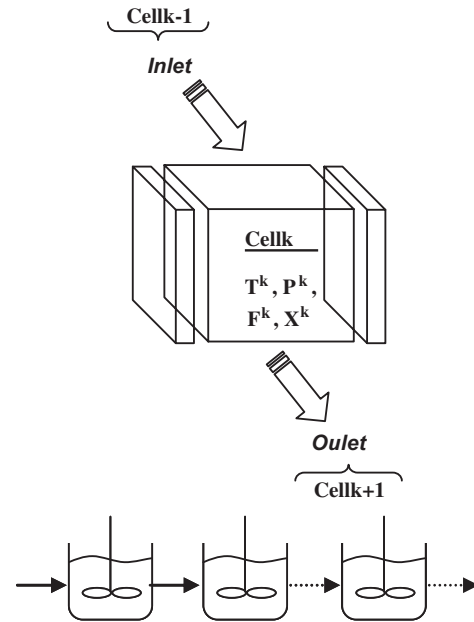

Fig. 5. Process flow modeling.

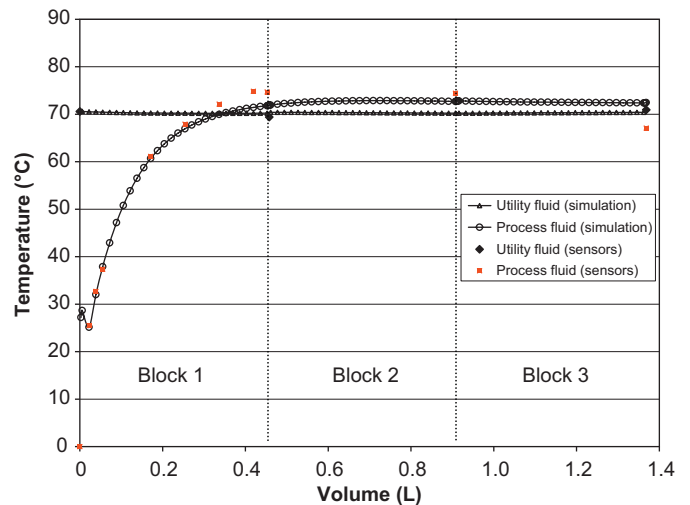

Fig. 6. Process and utility fluid temperature profiles along the OPR: simulation and experimental results.

The HAZOP method was then carried out on this process flow diagram in order to provide a full examination of the potential hazards in the OPR system and help to identify numerous scenarios when the standard operation fails.

An HAZOP team with expert knowledge of the process was established, including a team leader, a safety representative, three process engineers, two technicians and one simulation specialist. The basis of HAZOP is a “guide word examination,” which is a deliberate search for deviations from the design of the installation (according to International Standard IEC 61882, 2001). To facilitate the examination, the system was divided into seven parts:

- storage tanks containing water,
- storage tank containing reactant number 1 (propionic anhydride),
- storage tank containing reactant number 2 (2-butanol and sulfuric acid),

- propionic anhydride feeding line,
- 2-butanol and sulfuric acid feeding line,
- “heat-exchanger/reactor” OPR,
- utility fluid closed loop.

Each part contains the following elements: materials, activities, sources and destinations. The HAZOP team examined each element for deviations, which can lead to undesirable consequences. The identification of deviations was achieved by the questioning process using predetermined “guide words”. The role of the guide word is to stimulate imaginative thinking, to focus the study and promote ideas and discussion, thereby maximizing the chances of a maximum complete study. Basic guide words used were, for instance: no, more, less, as well as, reverse, etc. Using these standard key words successively on each part of the process, and each principal parameter (flow, temperature, pressure, initial composition), it was possible to define how

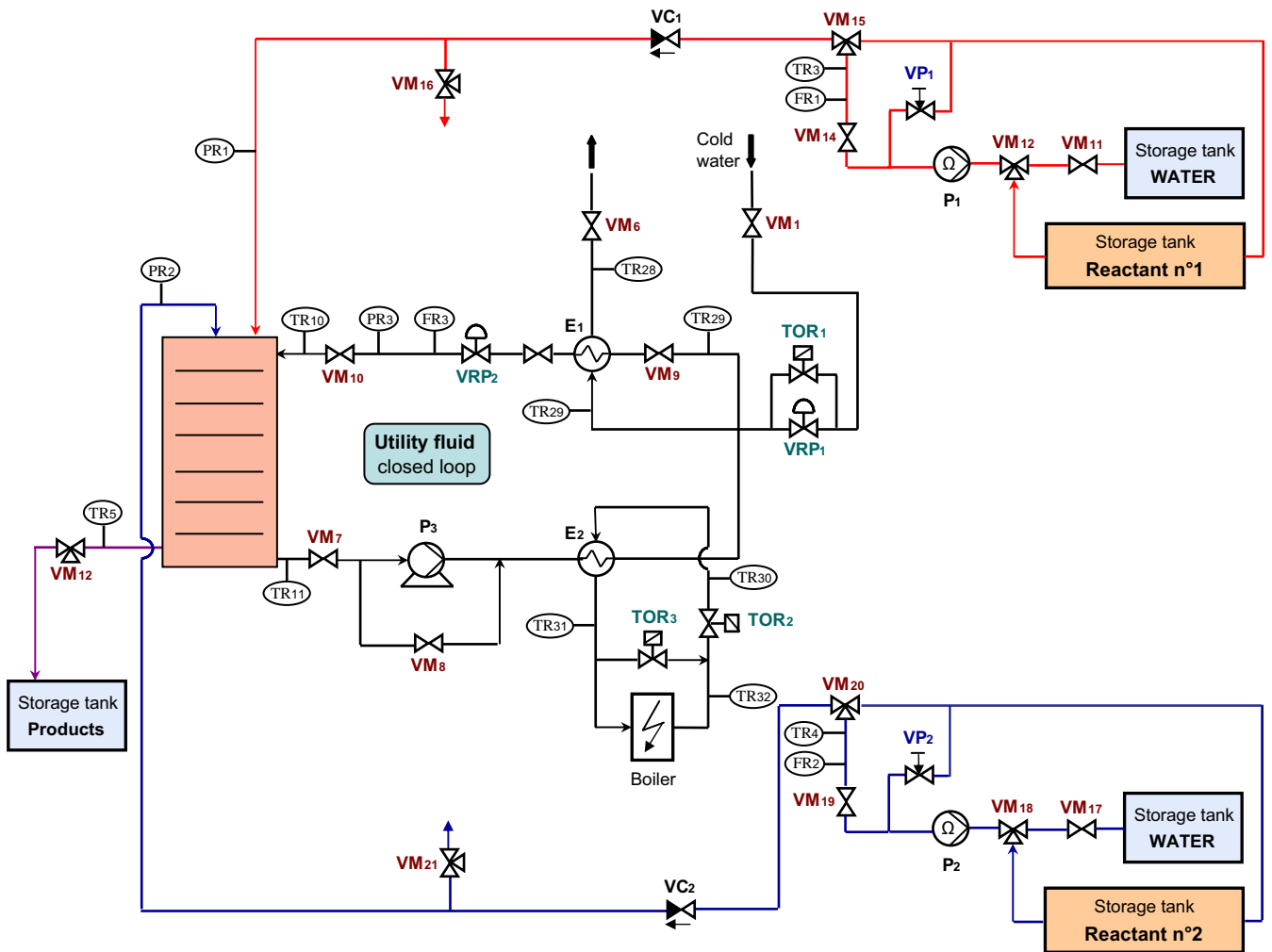

Fig. 7. Process and flow diagram of the pilot unit around the OPR.

**Table 2**  
HAZOP data sheet sample

Guide word	Deviation	Causes	Consequences	Action required
None	No utility flow	(1) $P_3$ pump fails (motor fault, electricity breakdown). (2) Line blockage, valve closed in error, clogging heat exchangers $E_1$ , $E_2$ .	(A) Loss of feed to utility section. (B) No possibility of cooling the reaction mixture in case of failure.	(a) Install flow alarm on reactor feed. (b) Regular control of the equipments: water tests.
None	No reactant flows	(3) $P_1/P_2$ pumps fails in the same time (motor fault, electricity breakdown). (4) Line blockage, valve closed in error, clogging of the reactive line.	(C) No circulation of the reaction mixture in the OPR. (D) Adiabatic increase in temperature.	(c) Install flow alarm on reactor feed. (d) Safety valve in order to empty the reactive line outside the reactor.

undesirable events can occur. The conclusions of the meeting have to be presented in a table, and to be as concise and clear as possible (Freeman, Lee, & McNamara, 1992). Table 2 illustrates the result data sheet, giving a short sample of the analysis carried out on the “heat-exchanger/reactor” OPR part.

Among all the potential hazards highlighted by the HAZOP method, three scenarios were identified as the most dangerous ones. These scenarios could potentially lead to a thermal runaway: no utility flow, no reactant flows, both stop of the utility and reactant line.

Although at the time of the analysis, it was not possible to identify precisely what would be the consequences of these scenarios, without

this information, it was impossible to set up appropriate safety measures and define the action required. The HAZOP results had then to be completed with further study about the process line evolution after failure to identify the dangerous issues.

## 5. Process line evolution after flows failure

When both process and utility fluids stop, another modeling has to be adopted, considering 91 closed cells independent from each other. After this deviation, the evolution of the liquid phase contained in a cell is determined only by the reaction inside it and

from transfer with its thermal environment, according to the following hypotheses:

- homogeneity of characteristic values (temperature, composition, etc.),
- homogeneity of physical properties (density, viscosity, etc.),
- homogeneity of physico-chemical phenomena (reaction, transfer, etc.),
- no variation of volume,
- no transfer between the cells.

What is then the final temperature profile reached inside the process line in the case of flows failure? Since each cell is considered as a stirred tank reactor, it is possible to calculate for each cell  $k$  the parameters used to build the runaway scenario diagram well-known in the field of chemical process safety methodologies (Stoessel, 1993): the adiabatic temperature rise ( $\Delta T_{ad}$ ) (Eq. (7)) and the maximum temperature of the synthesis reaction (MTSR) (Eq. (8)):

$$\Delta T_{ad}^k = \frac{\Delta Hr(1 - X^k)}{m_r^k C_{p_r}^k} \quad (7)$$

$$MTSR^k = T_0^k + \Delta T_{ad}^k \quad (8)$$

## 6. Thermal inertia of the OPR and adiabatic coefficient

The runaway scenario is usually set up for batch reactors in the case of a cooling failure: the evolution of the reactor switches in adiabatic mode. However, the OPR has one feature which makes it very interesting from a safety point of view: it has an important thermal inertia. The mass of the “heat-exchanger/reactor” is considerably greater than the reaction mixture, whereas it is the opposite for batch reactor. Indeed, each cell is surrounded by its own thermal environment made of different plates of the structure (Fig. 8):

- The reaction plate (RP) where the reaction mixture flows. It is built with PEEK, which is a plastic material able to resist very high temperatures and most of the corrosive chemical products.

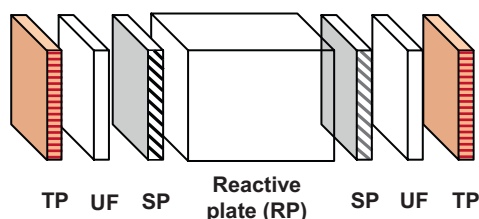

Fig. 8. Structure of the reactor by a sequence of different plates.

- Two stainless steel sandwich plates (SP) used to separate process and utility fluids.
- The area containing the utility fluid (UF) (water-glycol).
- Two stainless steel transition plates (TP) (left and right), which allow the thermal isolation of each block.

The first line of Table 3 gives the product of the mass by the heat capacity for each element of the thermal environment at the level of a cell. Compared with that of the reacting mass contained in the cell, these values are not negligible. It means that in the case of the OPR the mass of the reactor could play a role in the dissipation of the energy released by the reaction. Another parameter estimates the relative importance of the reactor mass: the adiabatic coefficient defined as the ratio of specific heats (Eq. (9)):

$$\Phi = 1 + \frac{\sum m_{TE} C_{p_{TE}}}{m_r C_{p_r}} \quad (9)$$

In the second line of Table 3 the coefficient is calculated taking each element separately ( $\Phi'$ ), and in the third line by adding the different terms successively ( $\Phi$ ). In a batch reactor, the adiabatic coefficient does not generally exceed 1.2. It is obvious that the coefficient is more important in the “heat-exchanger/reactor”, which confirms that the thermal inertia is an important factor in the study of the OPR.

According to these results, it is possible to consider that a part of the energy released by the reaction would be dissipated in the different parts of the reactor's structure. In this way, the calculation of the temperature rise has to take into account the thermal inertia of the reactor. For this purpose, Eq. (7) has to be changed as follows:

$$\Delta T_{ad}^k = \frac{\Delta Hr(1 - X^k)}{m_r^k C_{p_r}^k} \frac{1}{\Phi}. \quad (10)$$

Five scenarios have been studied:

- (1) the adiabatic case ( $\Phi' = 1$ ),
- (2) a part of the energy released is dissipated in the reaction plate ( $\Phi' = 1.28$ ),
- (3) a part of the energy released is dissipated in the sandwich plates ( $\Phi' = 1.41$ ),
- (4) a part of the energy released is dissipated at the same time in the reaction plate and in the sandwich plates ( $\Phi = 1.69$ ),
- (5) the energy is dissipated in the entire mass of the reactor ( $\Phi = 11.96$ ).

The reaction plates and sandwich plates are chosen because they are directly in contact with the process fluid. Fig. 9 shows the final temperature profiles along the reaction line reached after deviation. The initial conditions are given by a simulation for the following operating conditions: utility temperature (70 °C), utility

Table 3  
Mass and heat capacity product and adiabatic coefficients of the process fluid containing in one cell and in its thermal environment

	Process Reaction mixture	Thermal environment			
		Reaction plate (peek)	Sandwich plates (stainless steel)	Utility fluid (water glycol)	Transition plates (stainless steel)
$m_r C_{p_r}$ (J K <sup>-1</sup> )	29	8	12	44	254
$\Phi'$	1	1.28	1.41	2.51	9.76
$\Phi$	1	1.28	1.69	3.2	11.96



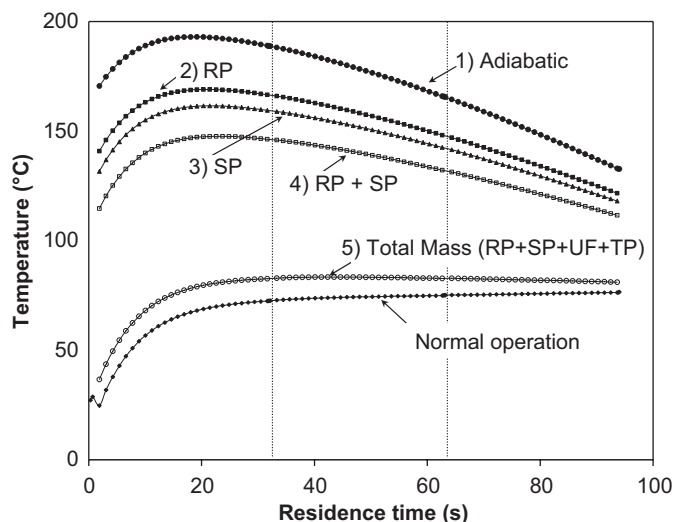

**Fig. 9.** Final temperature profiles reached by the reaction mixture along the OPR after flows stoppage according to five hypotheses (1–5).

flow rate ( $3 \text{ m}^3 \text{ h}^{-1}$ ), process flow rate (stoichiometric ratio) ( $50 \text{ L h}^{-1}$ ) and sulfuric acid mass fraction (0.8%) (Fig. 6).

The adiabatic mode is the least favorable for the thermal evolution of the reaction mixture; the relative curve provides therefore a border for the maximum temperature which can be reached by the process. We can also notice that the more high the adiabatic coefficient is, which means that the more important the mass taking part in the thermal dissipation is, the more the temperature profile decreases, which is very interesting regarding safety. However, this figure does not allow one to determine which curve would be effectively reached by the process. For an infinite time, we can assume that the energy would be dissipated by the total mass, but, meanwhile, what curve would be reached? Is it the adiabatic case or one of the other scenarios? To answer this question two characteristic times are introduced: one relative to the synthesis reaction and the other corresponding to the heat transfer in the reactor mass.

## 7. Characteristic times

### 7.1. Synthesis reaction

The first characteristic time is related to the kinetic of the synthesis and allows answering the question: how long does it take to reach the final temperature profiles after deviation from normal operation? This time can be obtained by the resolution of mass and energy balances for each cell taking the normal operation as the initial condition. The final condition is reached when the reaction is complete. Moreover, the mass equation has to be modified for each hypothesis as shown in Eq. (11). Table 4 gives the minimum time calculated for the 91 cells. For instance, it takes at least 18 s to reach the adiabatic curve from the normal operation one:

$$\frac{\partial T_r^k}{\partial t} = \frac{r_1 V^k \Delta H_r}{m_r^k C_{p_r}^k \phi} \quad (11)$$

### 7.2. Heat transfer inside the OPR

The second characteristic time is related to the heat transfer inside the reactor mass and allows one to answer the question: how long does it take to diffuse the energy in the different elements of the structure? In fact, when both fluids stop the

**Table 4**  
Minimum characteristic times to reach MTSR after deviation

	Minimum reaction time (s)
(1) Adiabatic	18
(2) Reaction plate	26
(3) Sandwich plates	29
(4) Reaction plates+sandwich plates	36
(5) Total mass	200

**Table 5**  
Heat transfer characteristic times for each part of the reactor's structure

	Heat transfer time (s)
Reaction plate	12
Sandwich plates	0.03

transfer mode is primarily conductive, each part of the structure behaving then like a resistance to the transfer. These resistances are characterized using the Biot number and the principles of the diffusion in solids (Peczalski & Laurent, 2001). Considering a solid at an initial temperature immersed in a fluid at constant temperature different from solid temperature, the characteristic time is defined as the time needed for the solid to reach the fluid temperature (Mac Cabe, Smith, & Harriott, 1993). This time is dependant on the thickness of the solid and on its physico-chemical properties. Table 5 gives the times calculated for the reaction plate and the sandwich plates.

### 7.3. Choice of a scenario

The two characteristic times have to be compared. We can observe that the heat-transfer times are considerably smaller (case of sandwich plates) than the reaction times or of the same order of magnitude (case of reaction plate). Therefore, we can consider the fourth assumption as acceptable. That this mean that in comparison with the adiabatic scenario, the maximum temperature would decrease up to  $60^\circ \text{C}$  (Fig. 9). Thus, the thermal inertia of the “heat-exchanger/reactor” allows it to be intrinsically safer.

## 8. Conclusion

Among the different ways to intensify a process, the possibility to move a chemical reaction from batch to plug-flow continuous processing mode is one of the most promising. From a safety point of view a lot of benefits are expected. Firstly, the smaller inventories engaged in this type of reactor will lead to minimize the consequences in case of hazard release. In addition, as demonstrated in this paper, the characteristics of the apparatus can also contribute to increase the safety aspect of the process.

In particular, this work was conducted to evaluate the behavior in a degraded mode of a continuous multi-plates heat-exchanger reactor when an exothermic reaction is carried out. The aim is to develop a safety study methodology in order to appreciate the inherently safer characteristics of this new concept of reactor.

First of all, a process risk assessment was performed with the HAZard and OPerability (HAZOP) method to highlight accidental scenarios leading to runaway. The likely major scenario chosen corresponds to the simultaneous stoppage of process and utility flows. To evaluate the consequences of this scenario, five assumptions concerning the thermal inertia of the apparatus are

considered, including the adiabatic case. Thus, a specific computer simulation program is used to calculate, on the one hand, the final temperature profiles reached by the reaction mixture along the OPR after flow stoppage and, on the other hand, the minimum characteristic times to reach the maximum temperature of the synthesis reaction (MTSR) after deviation. These times are then compared with the heat-transfer characteristic times in the different parts of the pilot structure. It shows that part of the energy released by the reaction would be dissipated at the same time in the plates closer to the reaction mixture: the reaction plate made of PEEK and sandwich plates made of stainless steel. The consideration of these “masses” in the heat-transfer phenomenon leads to a maximum temperature decrease reached after a failure of between 20 and 60 °C. This approach reveals an intrinsically safer behavior of this apparatus compared to batch reactors.

## Acknowledgments

The authors would like to thank Alfa Laval in supply of the “heat-exchanger/reactor” OPR and Data Processing Tool software, which have made this study possible. They also wish to thank Dominique Picque, Armelle Frazier, Lahcen Fahri, Jean-Louis Labat, Lucien Pollini and Marc Samazan for their technical support.

## References

- Benaissa, W. (2006). *Développement d'une méthodologie pour la conduite en sécurité d'un réacteur continu intensifié*. Ph.D. thesis, Institut National Polytechnique de Toulouse, France.
- Benaissa, W., Elgue, S., Gabas, N., Cabassud, M., Carson, D., & Demissy, M. (2008). Dynamic behaviour of a continuous heat exchanger/reactor after flow failure. *International Journal of Chemical Reactor Engineering* 6, A23 Available at: <<http://www.bepress.com/ijcre/vol6/A23>>.
- Dhanuka, V. R., Malshe, V. C., & Chandala, S. B. (1977). Kinetics of the liquid phase esterification of carboxylic acids with alcohols in the presence of acid catalysts: Re-interpretation of published data. *Chemical Engineering Science*, 32, 551–556.
- Elgue, S., Prat, L., Cabassud, M., & Cézerac, J. (2006). Optimisation of solvent replacement procedures according to economic and environmental criteria. *Chemical Engineering Journal*, 117, 169–177.
- Feliu, J. A., Iban, G., Alos, M. A., & Macias-Hernandez, J. J. (2003). Match your process constraints using dynamic simulation. *Chemical Engineering Progress*, 42–48.
- Freeman, R. A., Lee, R., & McNamara, T. P. (1992). Plan HAZOP studies with an expert system. *Chemical Engineering Progress*, 28–32.
- Galvan, I. M., Zaldivar, J. M., Hernandez, H., & Molga, E. (1996). The use of neural networks for fitting complex kinetic data. *Computers & Chemical Engineering*, 20(12), 1451–1465.
- Gustin, J. L. (2002). How the study of accident case histories can prevent runaway reaction accidents from recurring. *Transactions IChemE*, 80(Part B), 16–24.
- IEC, International Electrotechnical Commission. (2001). *Hazard and operability studies (HAZOP studies)—Application guide*. International Standard 61882.
- Jachuk, R. J. (2002). Process intensification for responsive processing. *Transactions IChemE*, 80(Part A), 233–238.
- Lees, F. P. (2001). *Loss prevention in the process industries*, Vol. 1. Oxford: Butterworth and Heinemann.
- Mac Cabe, W. L., Smith, J. C., & Harriott, P. (1993). *Unit operations of chemical engineering*. New York: McGraw-Hill.
- Maria, G., & Heinzle, E. (1998). Kinetic system identification by using short-cut techniques in early safety assessment of chemical processes. *Journal of Loss Prevention Process Industries*, 11, 187–206.
- Neuman, E. B. (2002). *Chemical reactor design, optimization, and scale up*. New York: McGraw-Hill.
- Peczalski, R., & Laurent, M. (2001). Outils simplifiés de calcul. *Techniques de l'Ingénieur*, F2 005.
- Phillips, C. H., Lausche, G., & Peerhossaini, H. (1997). Intensification of batch chemical processes by using integrated chemical reactor heat-exchangers. *Applied Thermal Engineering*, 17, 809–824.
- Prat, L., Devatine, A., Cognet, P., Cabassud, M., & Gourdon, C. (2005). Performance of a novel concept “open plate reactor” applied to highly exothermic reactions. *Chemical Engineering & Technology*, 28(9), 1028–1034.
- Snee, T. J., Barcons, C., Hernandez, H., & Zaldivar, J. M. (1992). Characterisation of an exothermic reaction using adiabatic and isothermal calorimetry. *Journal of Thermal Analysis*, 38, 2729–2747.
- Stankiewicz, A. (2003). *Re-engineering the chemical processing plant, Process intensification*. Aaaa: Marcel-Dekker.
- Stankiewicz, A., & Moulinj, J. A. (2002). Process intensification. *Industry Engineering Research*, 41, 1920–1924.
- Stoessel, F. (1993). What is your thermal risk? *Chemical Engineering Progress*, 68–75.
- Ubrich, O., Srinivasan, B., Lerena, P., Bonvin, D., & Stoessel, F. (1999). Optimal feed profile for a second order reaction in a semi-batch reactor under safety constraints: Experimental studies. *Journal of Loss Prevention Process Industries*, 12, 485–493.
- Ubrich, O., Srinivasan, B., Lerena, P., Bonvin, D., & Stoessel, F. (2001). The use of on-line optimisation of isothermal semi-batch reactors. *Chemical Engineering Science*, 56, 5147–5156.
- Zaldivar, J. M., Hernandez, H., Molga, E., Galvan, I. M., & Panetsos, F. (1993). The use of neural networks for the identification of kinetic functions of complex reactions. In *Proceedings of the third European symposium on computer aided process engineering, ESCAPE 3*.
- Zhang, J., & Smith, R. (2004). Design and optimisation of batch and semi-batch reactors. *Chemical Engineering Science*, 59, 459–478.