



**HAL**  
open science

# A polyhedral view to a generalization of multiple domination

José Neto

► **To cite this version:**

José Neto. A polyhedral view to a generalization of multiple domination. *Discrete Applied Mathematics*, 2022, 313, pp.1-17. 10.1016/j.dam.2022.01.011 . hal-03579253

**HAL Id: hal-03579253**

**<https://hal.science/hal-03579253>**

Submitted on 22 Jul 2024

**HAL** is a multi-disciplinary open access archive for the deposit and dissemination of scientific research documents, whether they are published or not. The documents may come from teaching and research institutions in France or abroad, or from public or private research centers.

L'archive ouverte pluridisciplinaire **HAL**, est destinée au dépôt et à la diffusion de documents scientifiques de niveau recherche, publiés ou non, émanant des établissements d'enseignement et de recherche français ou étrangers, des laboratoires publics ou privés.



Distributed under a Creative Commons Attribution - NonCommercial 4.0 International License

# A polyhedral view to a generalization of multiple domination

José Neto

*Samovar, Télécom SudParis, Institut Polytechnique de Paris,  
19 place Marguerite Perey, 91120 Palaiseau, France*

---

## Abstract

Given an undirected simple graph  $G = (V, E)$  and integer values  $f_v, v \in V$ , a node subset  $D \subseteq V$  is called an  $f$ -tuple dominating set if, for each node  $v \in V$ , its closed neighborhood intersects  $D$  in at least  $f_v$  nodes. We study the polytope that is defined as the convex hull of the incidence vectors in  $\mathbb{R}^V$  of the  $f$ -tuple dominating sets in  $G$ . New families of valid inequalities are introduced and a complete formulation is given for the case of stars. A corollary of our results is a proof that the conjecture reported in [Argiroffo, G., Proc. the 11th SIO, pp. 30-34, 2013] on a complete formulation of the 2-tuple dominating set polytope of trees does not hold. Preliminary computational results are also reported.

*Keywords:* dominating set, multiple domination, limited packing, polytope

---

## 1. Introduction

Let  $G = (V, E)$  denote an undirected simple graph with node set  $V = \{1, 2, \dots, n\}$  and edge set  $E$ . For every node  $v \in V$ , we denote by  $d_v^G$  (or more simply by  $d_v$  when  $G$  is clear from the context) its degree in  $G$ . Given a node subset  $S \subseteq V$ ,  $N(S)$  denotes the open neighborhood of  $S$ :  $N(S) = \{v \in V \setminus S : vw \in E \text{ for some node } w \in S\}$ , and  $N[S]$  stands for its *closed*

---

\*An extended abstract of a preliminary version of this paper appeared in the Proceedings of the International Symposium on Combinatorial Optimization 2018 (ISCO 2018). Lee J., Rinaldi G., Mahjoub A. (eds). Lecture Notes in Computer Science, vol 10856. Springer (2018) 352-363

*Email address:* [Jose.Neto@telecom-sudparis.eu](mailto:Jose.Neto@telecom-sudparis.eu) (José Neto)

*neighborhood*:  $N[S] = N(S) \cup S$ . When  $S$  is a singleton, i.e.  $S = \{v\}$  for some node  $v \in V$ , we will write  $N(v)$  (resp.  $N[v]$ ) in lieu of  $N(\{v\})$  (resp.  $N[\{v\}]$ ). The subgraph of  $G$  induced by some given node subset  $S \subseteq V$  is the graph  $G[S] = (S, E(S))$  with  $E(S) = \{uv \in E : (u, v) \in S^2\}$ . The incidence vector in  $\mathbb{R}^n$  of any node subset  $S \subseteq V$  is denoted by  $\chi^S$ :  $\chi_v^S = 1$  if  $v \in S$ , and  $\chi_v^S = 0$  otherwise.

Let  $\widehat{\mathcal{F}}_G$  (resp.  $\mathcal{F}_G$ ) stand for the following set of vectors indexed on the nodes of  $G$ :  $\widehat{\mathcal{F}}_G = \{f \in \mathbb{Z}_+^n : 0 \leq f_v \leq d_v + 1, v \in V\}$  (resp.  $\mathcal{F}_G = \{f \in \widehat{\mathcal{F}}_G : f_v \leq d_v, v \in V\}$ ). Given  $f \in \mathcal{F}_G$ , a node subset  $D \subseteq V$  is called an *f-dominating set* of  $G$  [24, 35, 10] if each node  $v$  in  $V \setminus D$  has at least  $f_v$  neighbors in  $D$ , i.e.  $|N(v) \cap D| \geq f_v$ . If the latter inequality holds for all the nodes in  $V$ , then  $D$  is called a *total f-dominating set* of  $G$  [11]. Given  $f \in \widehat{\mathcal{F}}_G$ , we define an *f-tuple dominating set* of  $G$  as a node subset  $D \subseteq V$  satisfying:  $|N[v] \cap D| \geq f_v$ , for all  $v \in V$ . The last three presented notions are generalizations of a *dominating set*, a *total dominating set* and a *k-tuple dominating set* (where  $k$  denotes a positive integer) from classical domination theory (see, e.g. [22]), respectively. The notion of *k-tuple dominating set* corresponds to the particular case of *f-tuple dominating set*, when  $f_v = k$ , for all  $v \in V$  [16, 21] [22, p. 189]. So, [similar to](#) the notion of total *f-dominating set*, for the case of an *f-tuple dominating set* all the nodes of the graph must satisfy a domination requirement (determined by  $f$ ) whereas this must be verified only by the nodes in  $V \setminus D$  for an *f-dominating set*  $D$ . But [different from](#) a total *f-dominating set*, the domination requirement for an *f-tuple dominating set* involves the closed neighborhoods of the nodes instead of the open ones. [To illustrate the differences](#) between the different three types of domination, consider for example the graph (a star) represented in Figure 1 where the number [close to node](#)  $v$  represents  $f_v$ . For this case a minimum cardinality *f-dominating set* is given by  $\{A\}$ , a minimum cardinality total *f-dominating set* is given by  $\{A, B, C, D\}$  and a minimum cardinality *f-tuple dominating set* is given by  $\{A, B, C\}$ . Another notion which is closely related to *f-tuple domination* is that of *f-limited packing* [16, 17]: Given  $f \in \widehat{\mathcal{F}}_G$ , an *f-limited packing* is a node subset  $S \subseteq V$  such that  $|N[v] \cap S| \leq f_v$ , for all

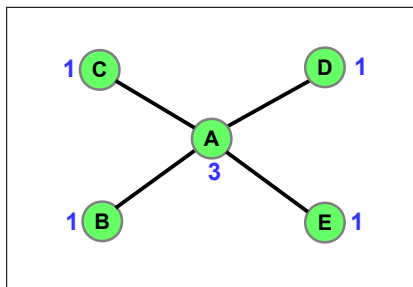

Figure 1: Example to illustrate the differences between concepts of domination

$v \in V$ . For the particular case when  $f_v = k$ , for all  $v \in V$ , for some positive integer  $k$ , we speak of  $k$ -limited packing. Let  $\tilde{f} \in \mathbb{Z}^n$  be defined as follows:  
 40  $\tilde{f}_v = d_v - f_v + 1$ , for all  $v \in V$ . Then,  $S$  is an  $f$ -limited packing if and only if  $V \setminus S$  is an  $\tilde{f}$ -tuple dominating set.

The *minimum weight  $f$ -tuple dominating set problem* denoted by  $[MW_f]$  can be stated as follows. Given an undirected simple graph  $G = (V, E)$ ,  $w \in \mathbb{R}_+^n$  and  $f \in \hat{\mathcal{F}}_G$ , find a minimum weight  $f$ -tuple dominating set of  $G$ , i.e. find a node subset  $S \subseteq V$  such that  $S$  is an  $f$ -tuple dominating set and the weight of  $S$ , given by  $\sum_{v \in S} w_v$ , is minimum. This problem can be formulated as the following integer linear program.

$$(IP1) \left\{ \begin{array}{l} \min \quad \sum_{v \in V} w_v x_v \\ s.t. \\ \sum_{u \in N[v]} x_u \geq f_v, v \in V, \\ x \in \{0, 1\}^n. \end{array} \right.$$

Let  $\mathcal{U}_G^f$  denote the convex hull of the feasible solutions of  $(IP1)$ , or equivalently, the convex hull of the incidence vectors in  $\mathbb{R}^n$  of the  $f$ -tuple dominating sets in  $G$ . It will be called the  *$f$ -tuple dominating set polytope* in what follows. Also, let  $(LP1)$  denote the linear relaxation of  $(IP1)$  (obtained replacing  
 45  $x \in \{0, 1\}^n$  by  $x \in [0, 1]^n$ ).

**Remark.** Let  $\mathcal{D}_G^f$  (resp.  $\mathcal{T}_G^f$ ) denote the convex hull in  $\mathbb{R}^n$  of the incidence vectors of the  $f$ -dominating (resp. total  $f$ -dominating) sets in  $G$ . One can

easily check the following inclusions hold:

$$\mathcal{T}_G^f \subseteq \mathcal{U}_G^f \subseteq \mathcal{T}_G^{f-\vec{1}} \subseteq \mathcal{D}_G^{f-\vec{1}}, \text{ and } \mathcal{T}_G^f \subseteq \mathcal{U}_G^f \subseteq \mathcal{D}_G^f,$$

where  $\vec{1}$  stands for the  $n$ -dimensional all-ones vector.

Observe that  $x \in \mathbb{R}^n$  is the incidence vector of an  $f$ -tuple dominating set if and only if  $\vec{1} - x$  is the incidence vector of an  $\tilde{f}$ -limited packing. This implies that the polytope defined as the convex hull of the incidence vectors of  $f$ -limited packings is affinely isomorphic<sup>1</sup> to  $\mathcal{U}_G^{\tilde{f}}$ . From this simple observation we can also deduce the following equation, which generalizes Lemma 5 in [17]:

$$\begin{aligned} & \max\{w^T \chi^S : S \text{ is an } f\text{-limited packing}\} + \\ & \min\{w^T \chi^R : R \text{ is a } (d + \vec{1} - f)\text{-tuple dominating set}\} = w^T \vec{1}, \end{aligned}$$

with  $d = (d_1, d_2, \dots, d_n)^T$ . Given this, we will simply focus on  $f$ -tuple domination in the next sections: the derivation of the corresponding results for  $f$ -limited packings are straightforward.

### Motivation

The concept of domination naturally arises in location problems for the strategic placement of facilities in a network. A wide variety of applications are presented in [22, 23], e.g., sets of representatives, location of radio stations, land surveying, etc. Considering the variant of  $f$ -tuple domination, and some of its extensions, they emerge notably for the design of fault tolerant wireless sensor networks, see, e.g., [34]. In that context it may be desirable to have several sensors monitoring the same target to deal with potential failures in the network. More generally, assume that the nodes of the graph  $G$  correspond to the places where some facility can be installed (fire station, school, hospital, etc.), two nodes being adjacent if the places corresponding to the endpoints are physically close or each one can be easily reached from the other. The fact of requiring more

---

<sup>1</sup>Two polytopes are said to be *affinely isomorphic* if there is an affine map that is a bijection between the points of the two polytopes [19, 37].

than one facility in the closed neighborhood of some place may be interpreted in terms of safety or quality of service in the sense that, if some installed facility in the neighborhood of a location  $v$  cannot be used for any reason and  $f_v \geq 2$ , then another one can be reached in the neighborhood of  $v$ . The fact of considering reliability requirements depending on the nodes allows also some flexibility of the model to account for practical matters. For example, with respect to the location of public facilities (hospitals, police stations, charging stations for electric cars...) one may require a higher number of these facilities close to places that are more densely populated. Still with respect to real contexts, the fact of considering not necessarily unit weights ( $w_v$ ) for the facilities accounts for possibly different costs related to the installation or dimensioning of the facility depending on the location. Limited packings arise for the strategic placement of obnoxious facilities [17] such as incinerators, garbage dumps, industrial plants: for each location (represented by some node in a graph), it is required that no more than some given number of such facilities are placed in its neighborhood.

#### *Related work*

The works we can find in the literature on  $f$ -tuple domination essentially focus on the case when looking for the minimum cardinality of a  $k$ -tuple dominating set (the case  $w = \vec{1}$  and  $f = k\vec{1}$ , for some positive integer  $k$  in the formulation (*IP1*)), which is also called the  *$k$ -tuple domination number*, as introduced in [20]. Most of these works deal with complexity and algorithmic aspects, or introduce bounds on the minimum cardinality of an  $f$ -tuple dominating set.

Decision problems corresponding to minimum cardinality  $k$ -tuple dominating set and maximum cardinality limited packing problems are known to be  $\mathcal{NP}$ -complete, even when considering restrictions on the input graph (split or bipartite) [13, 28]. Both cardinality problems can be solved in linear time when the input graph is a tree [12, 27]. For any  $f \in \widehat{\mathcal{F}}_G$ , a minimum cardinality  $f$ -tuple dominating set can be found in polynomial time in strongly chordal graphs, and in linear time if a strong ordering of the nodes is given [28]. Dobson et al. [13] have shown that the minimum cardinality  $k$ -tuple dominating set

and maximum cardinality  $k$ -limited packing problems can be solved in polynomial time in  $P_4$ -tidy graphs. Some peculiar graph families for which minimum  
 95 cardinality  $k$ -tuple dominating set and maximum cardinality  $k$ -limited packing problems can be polynomially reduced to each other were investigated in [26].

Gallant et al. [17] established bounds on the maximum cardinality of a  $k$ -limited packing and investigated structural properties of graphs for which some bounds are satisfied with equality. Several bounds on the  $k$ -tuple domination  
 100 number, some of which involve other domination parameters, are reported in [21]; other upper bounds obtained with probabilistic approaches are reported, e.g., in [15, 32, 36, 38]. The hardness of approximation for finding a minimum cardinality  $k$ -tuple dominating set was investigated by Klasing and Laforest in [25], where they present a  $(\ln|V| + 1)$ -approximation algorithm. They also show  
 105 that this problem cannot be approximated within a ratio of  $(1 - \epsilon)\ln|V|$  for any  $\epsilon > 0$  unless  $\mathcal{NP} \subseteq \text{DTIME}(|V|^{\log \log |V|})$ .

There are few works dedicated to polyhedral results related to  $f$ -tuple domination or limited packing problems. And for the existing ones, they essentially deal with the basic case when  $f = \vec{1}$ . In particular, a complete formulation  
 110 of the dominating set polytope (i.e. the  $\vec{1}$ -tuple dominating set polytope) for strongly chordal graphs is given by  $\{x \in [0, 1]^n : \sum_{u \in N[v]} x_u \geq f_v, v \in V\}$ . This follows from the fact the closed neighborhood matrix of strongly chordal graphs is totally balanced, see [1, 14] and Theorem 6.13 in [9]. Complete formulations of the dominating set polytope are also known for domishold graphs [29], cycles  
 115 [7] and some peculiar webs [6]; an extended formulation for the case of cacti graphs is presented in [3]. Recent investigations on polytopes related to other variants of domination: the concepts of  $f$ -domination and total  $f$ -domination, are reported in [10] and [11], respectively. There is also a much vaster literature on polyhedral aspects related to more general covering and packing concepts  
 120 and whose survey goes beyond the scope of this paper; see, e.g., [4, 9, 31]. But to the present author's knowledge, they do not cover the polyhedral results that we report hereafter [with respect to](#) the  $f$ -tuple dominating set polytope.

### *Our contributions*

The main contributions of the present paper can be summarized as follows.

125 We provide:

- New families of valid inequalities for  $\mathcal{U}_G^f$  together with sufficient conditions for these to be facet-defining, and results on the associated separation problem.
- Complete formulations for the  $f$ -tuple dominating set (and thus also for 130 the  $f$ -limited packing) polytopes of stars.
- The proof that a conjecture made by Argiroffo [2] on a complete formulation for the 2-tuple dominating set polytope of a tree does not hold.

In addition, we also present some further properties about formulations of the  $f$ -tuple dominating set polytope and preliminary computational results.

135 The paper is organized as follows. In Section 2, we investigate general properties related to the polyhedral structure of  $f$ -tuple dominating set polytopes. Then, in Section 3, we present and [study new families](#) of inequalities, showing that their addition to the relaxation ( $LP1$ ) leads to a complete formulation for the case of stars. Another family of valid inequalities, which led us to disprove 140 a conjecture on a complete formulation for the 2-tuple dominating set polytope of trees, is introduced in Section 4. A decomposition result and a procedure to get an extended formulation for trees are described in Section 5. Preliminary computational results are reported in Section 6, before we conclude in Section 7.

## 145 **2. General polyhedral properties**

In this section we present some important basic polyhedral results on  $\mathcal{U}_G^f$  which are relevant to our investigations. Their proofs are reported in Appendix A for completeness.



Given a polyhedron  $P$ , let  $\dim(P)$  denote its dimension. Also, let  $\mathcal{R} = \{v \in$   
150  $V: f_v = d_v + 1\}$ . Notice that for each node  $v \in \mathcal{R}$  its closed neighborhood is  
included in all feasible solutions of (IP1).

**Proposition 2.1.** *Let  $G = (V, E)$  denote an undirected simple graph and  $f \in$   
 $\widehat{\mathcal{F}}_G$ . Then  $\dim(\mathcal{U}_G^f) = |V| - |N[\mathcal{R}]|$ .*

**Remark.** Let  $G' = G[V \setminus \mathcal{R}]$  and define  $f' \in \mathcal{F}_{G'}$  and  $w' \in \mathbb{R}_+^{V \setminus \mathcal{R}}$  as follows:  
155  $f'_v = f_v - |N(v) \cap \mathcal{R}|$ , for all  $v \in V \setminus \mathcal{R}$ ,  $w'_v = w_v$ , for all  $v \in V \setminus N[\mathcal{R}]$  and  
 $w_v = 0$ , for all  $v \in N(\mathcal{R})$ . It is easy to check that an optimal solution to the  
problem  $[MW_f]$  defined by the parameters  $(G, f, w)$ , can be obtained by the  
union of the set  $N[\mathcal{R}]$  with an optimal solution of a problem having the same  
form and defined by the parameters  $(G', f', w')$ . So, given that the required  
160 nodes in  $\mathcal{R}$  have no particular relevance **with respect to** solving  $[MW_f]$  nor  
**with respect to** the polyhedral description of  $\mathcal{U}_G^f$  (which is obtained by adding  
to a description of  $\mathcal{U}_{G'}^{f'}$  the variables  $(x_v)_{v \in \mathcal{R}}$ , together with the set of equations:  
 $x_v = 1$ , for all  $v \in N[\mathcal{R}]$ ), in what follows, we shall always assume  $f \in \mathcal{F}_G$  unless  
otherwise stated. So, in particular, from Proposition 2.1, the polytope  $\mathcal{U}_G^f$  is  
165 full dimensional. In addition, we also assume the graph  $G$  has order at least  
2 (for non-triviality) and is connected (since otherwise we can work with each  
connected component separately).

The next proposition characterizes the trivial inequalities which are facet  
defining for  $\mathcal{U}_G^f$ .

170 **Proposition 2.2.** *Let  $f \in \mathcal{F}_G$  and  $u \in V$ . Then, the following holds.*

(i) *The inequality  $x_u \geq 0$  is facet-defining for  $\mathcal{U}_G^f$  iff (if and only if)  $f_v \leq$   
 $d_v - 1$ , for all  $v \in N[u]$ .*

(ii) *The inequality  $x_u \leq 1$  is facet-defining for  $\mathcal{U}_G^f$ .*

A very general property satisfied by any non trivial facet-defining inequality  
175 follows.

**Proposition 2.3.** Let  $a^T x \geq b$  denote a non trivial facet-defining inequality of  $\mathcal{U}_G^f$ , with  $f \in \mathcal{F}_G$ , and let its support be denoted by  $S = \{v \in V : a_v \neq 0\}$ . Then, the following holds:  $|S| \geq 2$ ,  $a_v \geq 0$ , for all  $v \in V$ , and  $b > 0$ .

We next formulate a simple sufficient condition for the so-called neighborhood inequalities present in (IP1) to be facet-defining.

**Proposition 2.4.** Let  $f \in \mathcal{F}_G$  and let  $u$  denote a node such that  $f_u = d_u$  and  $f_z \leq d_z - 1$ , for all  $z \in N(u)$  such that  $d_z \geq 2$ . Then, the neighborhood inequality

$$\sum_{v \in N[u]} x_v \geq f_u (= d_u) \tag{1}$$

is facet-defining for  $\mathcal{U}_G^f$ .

**Remark.** Let  $E_0 = \{uv \in E : f_u = f_v = 0\}$  and define  $G_0 = (V, E \setminus E_0)$  as the graph obtained from  $G$  by removing the edges in  $E_0$ . Then, observe that  $\mathcal{U}_G^f = \mathcal{U}_{G_0}^f$  and also that a complete formulation of  $\mathcal{U}_G^f$  is obtained by aggregating the ones corresponding to the connected components of  $G_0$ .

### 3. Star inequalities

In this section we introduce two families of valid inequalities for the polytope  $\mathcal{U}_G^f$  and investigate some of their properties. In particular, we present sufficient conditions for them to be facet defining, and we show that together with the inequalities in the relaxation (LP1) they provide a complete formulation of  $\mathcal{U}_G^f$  for the case of star graphs. We named these two families of inequalities *star-1* and *star-2 inequalities* owing to the latter result, the fact that their support is contained in the closed neighborhood of a single node, and also to distinguish them from the well-known neighborhood inequalities (1). Omitted proofs of this section are postponed to Appendix B. We may stress here the fact that the validity of star-1 and star-2 inequalities and the related results given in sections 3.1-3.3 are not restricted to star graphs. (A restriction to star graphs is considered only in Section 3.4, where we establish the complete description result of  $\mathcal{U}_G^f$  for this particular graph family.)

200 3.1. Star-1 inequalities

**Definition 3.1.** Let  $G = (V, E)$  denote an undirected simple graph and let  $f \in \mathcal{F}_G$ . Given any node  $u$ , let  $L_0 = \{v \in N(u) : f_v \leq d_v - 1\}$ , and  $L_1 = N(u) \setminus L_0$ . Then, an inequality of the following form is called a star-1 inequality.

$$[\max(|L_1|, f_u) - f_u + 1]x_u + \sum_{v \in N(u)} x_v \geq \max(|L_1|, f_u). \quad (2)$$

**Proposition 3.2.** Under the setting of Definition 3.1, the star-1 inequality (2) is valid for  $\mathcal{U}_G^f$ .

In order to ease the presentation of some properties of star inequalities, let us formulate the following technical assumption.

205 **Assumption A.** Let  $G = (V, E)$  be an undirected simple graph,  $f \in \mathcal{F}_G$  and  $u \in V$ . Let  $(L_0, L_1)$  denote a partition of  $N(u)$  with  $L_0 = \{v \in N(u) : f_v \leq d_v - 1\}$ , and  $L_1 = N(u) \setminus L_0$  (possibly  $L_0 = \emptyset$  or  $L_1 = \emptyset$ ). Assume that  $G[N[u]]$  is a star (i.e.  $N(u)$  is a stable set in  $G$ ), and that for each node  $w \in V \setminus N[u]$  at least one of the following items holds:

- 210
- $|N(w) \setminus N(u)| \geq f_w$  and  $N(w) \cap N(u) \subseteq L_0$  (with the convention that  $\emptyset \subseteq L_0$  always holds), or
  - $|N(w) \cap N(u)| = 1$  and  $f_w \leq d_w - 1$ .
  - $|N(w) \cap N(u)| = 1$  and  $N(z) \cap N(u) = \emptyset$  for all  $z \in N(w) \setminus N(u)$ ,
  - $|N(w) \cap N(u)| = 0$ .

215 Note that in view of the last two items specifying conditions on the nodes in  $V \setminus N[u]$ , Assumption A is clearly satisfied if  $G$  is a tree and  $f \in \mathcal{F}_G$ . However the validity of this assumption is not restricted to this graph family. For example, Assumption A also holds if we consider any graph  $G$ ,  $f \in \mathcal{F}_G$ , such that  $G$  contains a node  $u$  for which  $G[N[u]]$  is a star, and the set  $S_u^2$  of the nodes at distance exactly 2 from  $u$  satisfies the third item above (i.e. 220  $|N(w) \cap N(u)| = 1$  and  $N(z) \cap N(u) = \emptyset$  for all  $w \in S_u^2$ ,  $z \in N(w) \setminus N(u)$ ). See, for example, the graph of Figure 2 for an illustration (where the number

close to a node  $v \neq u$  represents  $f_v$ ). For this particular case with  $f_u = 2$ , it follows from the next result that the star-1 inequality  $2x_u + \sum_{v \in N(u)} x_v \geq 3$  is facet-defining with respect to  $\mathcal{U}_G^f$ .

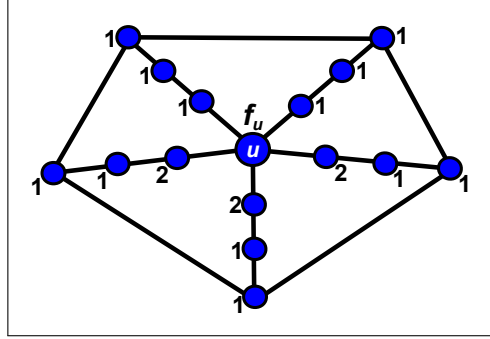

Figure 2: Example to illustrate star inequalities

225

**Proposition 3.3.** *Suppose that Assumption A holds with  $f_u \geq 2$ . Then the inequality (2) is facet-defining with respect to  $\mathcal{U}_G^f$ .*

*Proof.* We do the proof for the case  $f_u \geq |L_1|$ . (The case when  $f_u < |L_1|$  can be treated similarly.) Let  $a^T x \geq b$  denote an inequality defining a facet  $F$  of  $\mathcal{U}_G^f$  such that the face defined by (2) is contained in  $F$ . We prove that  $a^T x \geq b$  must correspond to (2) up to multiplication by a positive scalar.

Let  $w \in V \setminus N[u]$ . Let  $z$  denote a neighbor of  $u$  belonging to an elementary chain joining  $w$  and  $u$  in  $G$ . Consider then the  $f$ -tuple dominating set  $D$  defined by  $D = \{z\} \cup Q \cup (V \setminus N[u])$ , where  $Q$  denotes a set of exactly  $f_u - 1$  nodes in  $N[u] \setminus \{z\}$  containing  $u$ . Notice that the incidence vector of  $D$  satisfies (2) with equality and the latter also holds for the incidence vector of  $D \setminus \{w\}$  which is also an  $f$ -tuple dominating set in  $G$  (using Assumption A). Thus  $a_w = 0$ , and this holds for any node  $w \in V \setminus N[u]$ .

Let  $v_1, v_2$  denote two distinct neighbors of  $u$ . We define two  $f$ -tuple dominating sets as follows:  $D_1 = \{u, v_1\} \cup S \cup (V \setminus N[u])$ ,  $D_2 = D_1 \Delta \{v_1, v_2\}$ , where  $S$  stands for a set of exactly  $f_u - 2$  nodes in  $N(u) \setminus \{v_1, v_2\}$ . Since  $D_1$  and  $D_2$  correspond to  $f$ -tuple dominating sets in  $G$  whose incidence vectors satisfy (2)

with equality, we deduce  $a_{v_1} = a_{v_2}$ . It follows that  $a_v = c_1$ , for all  $v \in N(u)$  with  $c_1 \in \mathbb{R}_+$ .

245 Considering now an  $f$ -tuple dominating set containing  $u$  whose incidence vector satisfies (2) with equality, we deduce  $a_u + (f_u - 1)c_1 = b$ . Proceeding similarly for an  $f$ -tuple dominating set not containing  $u$ , we obtain  $b = f_u c_1$ . Thus, the inequality  $a^T x \geq b$  corresponds to (2) up to multiplication by a positive scalar.  $\square$

### 250 3.2. Star-2 inequalities

**Definition 3.4.** Let  $G = (V, E)$  denote an undirected simple graph and let  $f \in \mathcal{F}_G$ . Given any node  $u$  with  $f_u \geq 3$ , let  $L_0 = \{v \in N(u) : f_v \leq d_u - 1\}$ , and  $L_1 = N(u) \setminus L_0$ . Then, an inequality of the following form is called a star-2 inequality:

$$(|L_1| - f_u + |Z| + 1)x_u + \sum_{v \in L_1 \cup (L_0 \setminus Z)} x_v \geq |L_1|, \quad (3)$$

with  $Z \subseteq L_0$  satisfying  $\max(0, f_u - |L_1|) < |Z| < f_u - 1$  (in case such a set exists).

To illustrate the family of star-2 inequalities, consider again the graph of Figure 2, but now with  $f_u = 3$ . Then the inequality  $2x_u + \sum_{v \in N(u) \setminus \{a\}} x_v \geq 3$  belongs to this family, where  $a$  denotes a neighbor of the node  $u$  satisfying  $f_a = 1$ . From the next results, it turns out that this inequality is in fact also facet-defining with respect to  $\mathcal{U}_G^f$ .

**Proposition 3.5.** Under the setting of Definition 3.4, the star-2 inequality (3) is valid for  $\mathcal{U}_G^f$ .

260 **Proposition 3.6.** Suppose that Assumption A holds with  $f_u \geq 3$ . Then, the inequalities (3) are facet-defining for  $\mathcal{U}_G^f$ .

*Proof.* Let  $\alpha^T x \geq \beta$  represent an inequality of the type (3), and  $\bar{V}$  denote the node subset  $V \setminus N[u]$ . Let  $a^T x \geq b$  denote a facet-defining inequality of  $\mathcal{U}_G^f$ , such that the facet it defines contains the face of  $\mathcal{U}_G^f$  defined by  $\alpha^T x \geq \beta$ , i.e.

265  $\{x \in \mathcal{U}_G^f: \alpha^T x = \beta\} \subseteq \{x \in \mathcal{U}_G^f: a^T x = b\}$ . We show that  $a^T x \geq b$  must correspond to  $\alpha^T x \geq \beta$ , up to multiplication by a positive scalar.

Let  $w \in \bar{V}$  and let  $S$  denote a subset of  $f_u$  nodes in  $N[u]$  such that

- $\{u, t\} \cup Z \subseteq S$ , if there exists  $t \in N(u)$  such that  $\{t\} = N(w) \cap N(u)$ ,
- $\{u\} \cup Z \subset S$ , otherwise.

270 Then, define  $D = \bar{V} \cup S$ ,  $D' = (\bar{V} \setminus \{w\}) \cup S$  and note that  $D$  and  $D'$  are  $f$ -tuple dominating sets. (This relies on the assumption made in the statement of the proposition about the nodes in  $\bar{V}$ .) And since we have  $a^T \chi^D = a^T \chi^{D'} = b$ , we can deduce  $a_w = 0$ .

Let  $w \in Z$  and define  $D = \bar{V} \cup (L_1 \cup Z)$ ,  $D' = \bar{V} \cup (L_1 \cup Z) \setminus \{w\}$ . Since  $D$  275 and  $D'$  are  $f$ -tuple dominating sets satisfying  $a^T \chi^D = a^T \chi^{D'} = b$ , we deduce  $a_w = 0$ .

If  $|(L_1 \cup L_0) \setminus Z| \geq 2$ , consider  $w_1, w_2$  in the set  $(L_1 \cup L_0) \setminus Z$ , and let  $S$  denote a subset of  $f_u$  nodes in  $N[u]$  such that  $Z \subset S$ ,  $\{u, w_1\} \subset S$ ,  $w_2 \notin S$ , and define  $S' = S \Delta \{w_1, w_2\}$ . Since  $\bar{V} \cup S$  and  $\bar{V} \cup S'$  are  $f$ -tuple dominating sets satisfying 280  $a^T \chi^{\bar{V} \cup S} = a^T \chi^{\bar{V} \cup S'}$ , we deduce  $a_{w_1} = a_{w_2}$ . From now on, let  $\theta$  denote the value of the coefficient  $a_v$ , for any node  $v \in (L_1 \cup L_0) \setminus Z$ .

Since the incidence vectors of the sets  $S$  (as defined in the last paragraph above) and  $\bar{V} \cup L_1 \cup Z$  satisfy the equation  $\alpha^T x = \beta$ , we deduce  $a_u + (f_u - 1 - |Z|)\theta = b = |L_1|\theta$ . Thus,  $a_u = (L_1 - f_u + |Z| + 1)\theta$  and it follows that  $a^T x \geq b$  corresponds 285 to (3) up to multiplication by a positive scalar.  $\square$

As [another](#) example of type (3) inequality, consider the star on eleven nodes illustrated by Figure 3-(a), together with the domination requirements  $(f_v)_{v \in V}$  reported close to each node. For the represented subsets  $L_0, L_1$  and  $Z$  of the leaves, the corresponding facet-defining inequality is  $4x_1 + \sum_{v \in L_1 \cup (L_0 \setminus Z)} x_v \geq 5$ . 290 Note that since  $\mathcal{U}_G^f$  is full dimensional (assuming  $f \in \mathcal{F}_G$ ), the facets defined by the inequalities of type (3) are all distinct. Given this, a relevant consequence of Proposition 3.6 is the fact that there exist families of dominating set polytopes for which the number of facets grows exponentially with the number of nodes of

Figure 3: Examples to illustrate star inequalities

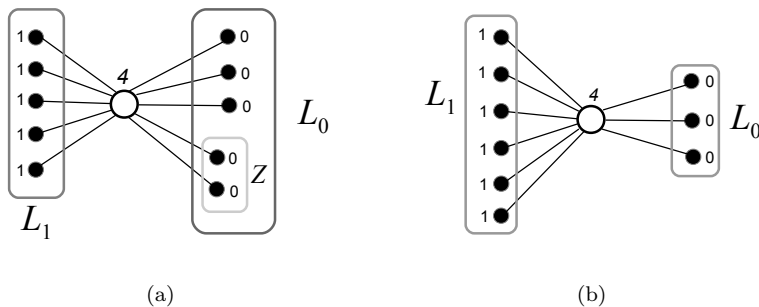

the corresponding graph. As an example, consider a star of even order  $n$ , and  
 295 let  $f \in \mathcal{F}_G$  such that  $f_1 = \frac{n}{2} - 1$ ,  $|L_0| = \frac{n}{2} - 2$  (and thus  $|L_1| = \frac{n}{2} + 1$ ), see the  
 illustration given in Figure 3-(b). Then the number of type (3) inequalities is  
 $\Omega(2^{n/2})$ . This contrasts with the *classical* dominating set polytope  $\mathcal{U}_G^{\bar{1}}$  for which  
 the number of facets is  $\mathcal{O}(n)$  for strongly chordal graphs [14]. The potential  
 exponential number of star-2 inequalities raises the question of the complexity  
 300 of the corresponding separation problem that is addressed in the next section.

### 3.3. Separation of star inequalities

Given a vector  $x \in \mathbb{R}^V$ , the separation problem with respect to  $\mathcal{U}_G^f$  consists  
 in determining if  $x \in \mathcal{U}_G^f$ , and if not, in exhibiting an inequality that is valid for  
 $\mathcal{U}_G^f$  but violated by  $x$ .

Obviously star-1 inequalities can be checked in polynomial time. We now de-  
 scribe a procedure showing that this result also holds for star-2 inequalities. re-  
 suming the notation from the Definition 3.4, for each node  $u \in V$  with  $f_u \geq 3$ ,  
 we can proceed as follows. Firstly, we check if  $|L_0| > \max(0, f_u - |L_1|)$  and  
 $f_u - 1 - \max(0, f_u - |L_1|) \geq 2$ . If this is not satisfied, then there is no inequal-  
 ity (3) to be considered. Otherwise, observe that inequality (3) can be rewritten  
 as follows.

$$(|L_1| - f_u)x_u + \left( \sum_{v \in N[u]} x_v \right) + \left( \sum_{v \in Z} x_u - x_v \right) \geq |L_1|, \quad (4)$$

with  $Z \subseteq L_0$  satisfying  $\max(0, f_u - |L_1|) < |Z| < f_u - 1$ .

Let  $\{1, 2, \dots, p\}$  denote the neighbors of node  $u$  in  $L_0$ , ordered so that  $(x_u - x_1) \leq (x_u - x_2) \leq \dots \leq (x_u - x_p)$ . Let  $q$  denote the largest index such that  $(x_u - x_q) < 0$  and  $q \leq f_u - 2$ , with the convention that  $q = 0$  if  $(x_u - x_1) \geq 0$ . Let  $r = \max(1, f_u - |L_1| + 1, q)$  and set  $\widehat{Z} = \{1, 2, \dots, r\}$ . Clearly, from the expression (4),  $\widehat{Z}$  is a node subset of  $N(u)$  minimizing  $\sum_{v \in Z} x_u - x_v$  subject to  $Z \subseteq L_0$  and  $\max(0, f_u - |L_1|) < |Z| < f_u - 1$ . Thus, by evaluating the left-hand side of (3) with  $Z = \widehat{Z}$  we can determine if, for the node  $u$  we consider, all the inequalities (3) are satisfied. And since  $\widehat{Z}$  can be determined in polynomial time the next result follows.

**Proposition 3.7.** *Inequalities (3) can be separated in polynomial time.*

#### 3.4. A complete formulation of $\mathcal{U}_G^f$ for stars

In this subsection we show that the star-1 and star-2 inequalities introduced above, together with the inequalities present in (LP1), provide a complete formulation of  $\mathcal{U}_G^f$  when  $G$  is a star.

**Lemma 3.8.** *Let  $G = (V, E)$  be a star having for center the node 1, let  $f \in \mathcal{F}_G$ , and  $a^T x \geq b$  denote a non trivial facet-defining inequality of  $\mathcal{U}_G^f$ . Then,  $a_1 > 0$ .*

*Proof.* Assume for a contradiction that  $a_1 = 0$ . By Proposition 2.3,  $b > 0$  and  $|\{v \in V : a_v > 0\}| \geq 2$ . Also, there exists an  $f$ -tuple dominating set  $D$  such that  $1 \notin D$  and  $a^T \chi^D = b$  (because otherwise the face defined by  $a^T x \geq b$  would be contained in the one defined by the trivial inequality  $x_1 \leq 1$ , a contradiction). Consider any node  $w \in D$  such that  $a_w > 0$ . Then,  $D' = D \setminus \{w\} \cup \{1\}$  is an  $f$ -tuple dominating set and  $a^T \chi^{D'} < b$ , a contradiction.  $\square$

For the case when the graph  $G = (V, E)$  is a star having for center the node 1 and  $f_1 \in \{0, 1\}$ , the trivial inequalities together with the neighborhood inequalities provide a complete formulation of the polytope  $\mathcal{U}_G^f$ . This follows from the total balancedness of the closed neighborhood matrix (see [1, 8]) for such a case. So, in the rest of this section we assume  $f_1 \geq 2$  and  $n \geq 3$ .



330 **Proposition 3.9.** *Let  $G = (V, E)$  denote a star with order  $n \geq 3$  and having node 1 for center. Let  $f \in \mathcal{F}_G$  such that  $f_1 \geq 2$ . Then, a complete description of  $\mathcal{U}_G^f$  is given by the set of the trivial inequalities, the neighborhood inequalities of the nodes in  $L_1 = \{v \in N(1): f_v = 1\}$ , and the inequalities (2)-(3) (taking  $u = 1$  in the expressions of (2)-(3)).*

335 *Proof.* Let  $a^T x \geq b$  denote a facet-defining inequality of  $\mathcal{U}_G^f$  that is not trivial and different from a neighborhood inequality of a node in  $L_1$ . Using the next four claims whose proofs are postponed to Appendix B for clarity of exposition, we show that it must correspond (up to multiplication by a positive scalar), to an inequality of the type (2) or (3). In what follows we denote by  $Z_0$  the node subset  $Z_0 = \{v \in V: a_v = 0\}$ , also  $L_0 = N(1) \setminus L_1$ . Note that by Lemma 3.8, 340 we have  $1 \notin Z_0$ .

*Claim 1.* *If  $L_1 \neq \emptyset$ , then  $a_v = \alpha$ , for all  $v \in L_1$ , with  $\alpha > 0$ .*

345 *Claim 2.* *If  $Z_0 = \emptyset$ , then  $a_v = \alpha$ , for all  $v \in V \setminus \{1\}$ , with  $\alpha > 0$ .*

*Claim 3.* *If  $Z_0 \neq \emptyset$ , then  $L_1 \neq \emptyset$  and  $f_1 - |L_1| < |Z_0| < f_1 - 1$ .*

*Claim 4.* *If  $Z_0 \neq \emptyset$ , then  $a_v = \alpha$ , for all  $v \in L_1 \cup (L_0 \setminus Z_0)$ , with  $\alpha > 0$ .*

350

Making use of the four claims above, we establish a relation between  $a_1$  and  $\alpha$ . Let  $D$  stand for an  $f$ -tuple dominating set such that  $a^T \chi^D = b$  and  $1 \notin D$ . Then, necessarily  $L_1 \subseteq D$ , and

- if  $Z_0 = \emptyset$ : Claim 2 implies  $b = \max(f_1, |L_1|)\alpha$ .
- 355 • if  $Z_0 \neq \emptyset$ : Claim 1 implies  $Z_0 \cap L_1 = \emptyset$ . Then, by Claim 3 we have  $|Z_0 \cup L_1| > f_1$ , and thus  $Z_0 \cup L_1$  is an  $f$ -tuple dominating set. This implies  $b \leq a^T \chi^{Z_0 \cup L_1} \leq a^T \chi^D = b$ , where the second inequality follows from the nonnegativity of  $a$  (Proposition 2.3). It follows that  $a_v = 0$ , for all  $v \in D \setminus L_1$ . By Claim 4, we deduce  $b = \alpha|L_1|$ .

360 Now let  $\tilde{D}$  stand for an  $f$ -tuple dominating set such that  $a^T \chi^{\tilde{D}} = b$  and  $1 \in \tilde{D}$ . Then,

- if  $Z_0 = \emptyset$ :  $a_1 = \alpha(\max(f_1, |L_1|) - f_1 + 1)$ ,
- if  $Z_0 \neq \emptyset$ :  $a_1 = \alpha(|L_1| - f_1 + 1 + |Z_0|)$ .

□

#### 365 4. Extended neighborhood inequalities

In this section, we introduce inequalities generalizing the star-2 inequalities (3) presented above. We investigate on their facet-defining properties and related separation problem. The obtained results notably lead us to disprove a conjecture on a complete formulation of the 2-tuple dominating set polytope for  
370 trees. Omitted proofs from this section are postponed to Appendix C.

##### 4.1. Definition and properties

**Definition 4.1.** Let  $G = (V, E)$  denote an undirected simple graph,  $f \in \mathcal{F}_G$ . Let  $u \in V$ , and let  $(Z, L_0, L_1)$  denote a tripartition of  $N(u)$  satisfying all the following conditions.

375 (i)  $f_u - |L_1| \leq |Z| \leq f_u - 1$ ,

(ii) for each node  $w \in L_1$ ,  $f_w \geq 1$ .

For each node  $w \in L_1$ , let  $\bar{N}(u, w)$  denote a subset of  $N[w] \setminus \{u\}$  such that  $w \in \bar{N}(u, w)$  and  $|\bar{N}(u, w)| = d_w - f_w + 1$ . Also, let  $\bar{N} = \cup_{w \in L_1} \bar{N}(u, w)$ . Then, an inequality of the following form is called an extended neighborhood inequality.

$$(|L_1| - f_u + |Z| + 1)x_u + \left( \sum_{w \in L_1} \sum_{v \in \bar{N}(u, w)} x_v \right) + \sum_{v \in L_0 \setminus \bar{N}} x_v \geq |L_1|. \quad (5)$$

**Proposition 4.2.** Under the setting of Definition 4.1, the extended neighborhood inequality (5) is valid for  $\mathcal{U}_G^f$ .

For an example of inequality of type (5), consider the graph (a tree) given in  
 380 Figure 4, where the node requirements  $(f_v)_{v \in V}$  correspond to the values close to  
 the nodes. Taking for  $u$  the node 1, considering the tripartition of  $N(u)$ : ( $Z =$   
 $\{6\}$ ,  $L_0 = \{5\}$ ,  $L_1 = \{2, 3, 4\}$ ) and the sets  $\bar{N}(1, 2) = \{2, 7\}$ ,  $\bar{N}(1, 3) = \{3, 9\}$   
 and  $\bar{N}(1, 4) = \{4, 10\}$ , we obtain the following inequality:  $2x_1 + x_2 + x_3 + x_4 +$   
 $x_5 + x_7 + x_9 + x_{10} \geq 3$ .

Figure 4: Illustration for an inequality of type (5)

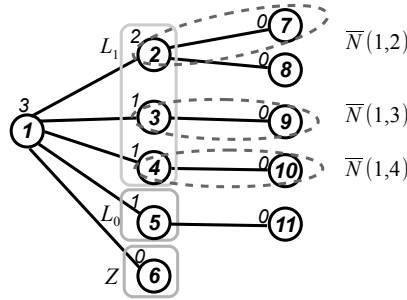

385 We now specify sufficient conditions under which inequality (5) is facet-  
 defining. To do so, we first formulate an assumption which may be viewed as  
 an extension of Assumption A for inequality (5). Given any node  $u \in V$ ,  $N^2[u]$   
 denotes the node subset  $N[N[u]]$ , i.e. the set of all the nodes at distance at  
 most two from node  $u$ .

390 **Assumption B.** Let  $G = (V, E)$  be an undirected simple graph,  $f \in \mathcal{F}_G$  and  
 $u \in V$ . Assume that  $G[N^2[u]]$  is a tree, and at least one of the following items  
 holds, for all  $w \in V \setminus N[u]$  :

- $|N(w) \setminus N(u)| \geq f_w$  and  $N(w) \cap N(u) \subseteq L_0$  (with the convention that  $\emptyset \subseteq L_0$  always holds), or
- 395 •  $|N(w) \cap N(u)| = 1$  and  $f_w \leq d_w - 1$ .
- $|N(w) \cap N(u)| = 1$  and  $N(z) \cap N(u) = \emptyset$  for all  $z \in N(w) \setminus N(u)$ ,
- $|N(w) \cap N(u)| = 0$ .

**Proposition 4.3.** *Suppose that Assumption B holds with  $f_u \geq 2$ , and that there exists a tripartition  $(Z, L_0, L_1)$  of  $N(u)$  such that*

- 400 (i)  $f_u - |L_1| < |Z| < f_u - 1$ ,
- (ii)  $f_v \leq d_v - 1$ , for all  $v \in Z \cup L_0$ ,
- (iii) for each node  $w \in L_1$ ,  $f_w \geq 1$  and  $|Q_w| \geq d_w - f_w$ , with  $Q_w = \{v \in N(w) \setminus \{u\} : f_v \leq d_v - 1\}$ .

For each node  $w \in L_1$ , let  $\bar{N}(u, w)$  denote a subset of  $Q_w \cup \{w\}$  such that  
 405  $w \in \bar{N}(u, w)$  and  $|\bar{N}(u, w)| = d_w - f_w + 1$ .

Then, the inequality (5) is facet-defining *with respect to*  $\mathcal{U}_G^f$ .

*Proof.* Let  $a^T x \geq b$  denote an inequality defining a facet  $F$  of  $\mathcal{U}_G^f$  such that the face defined by (5) is contained in  $F$ . We show that  $a^T x \geq b$  must correspond to (5), up to multiplication by a positive scalar. Let  $\mathcal{S}$  denote the nodes corresponding to the support of (5):  $\mathcal{S} = (N[u] \setminus Z) \cup (\cup_{w \in L_1} \bar{N}(u, w))$ .  
 410

Let  $w \in Z$ . Let  $R = (V \setminus (\mathcal{S} \cup \{w\})) \cup L_1$ . Note that, from our assumptions,  $|L_1| + |Z| > f_u$  and thus, the node  $u$  domination requirement is satisfied by  $R$ . Since  $f_w \leq d_w - 1$  and all the neighbors of  $w$  but  $u$  belong to  $R$ ,  $|R \cap N(w)| = d_w - 1 \geq f_w$ . Using Assumption B, for any node  $v \in V \setminus (\mathcal{S} \cup \{w\})$ ,  
 415  $|R \cap N[v]| \geq f_v$ . For any node  $v \in L_0$  all its neighbors but  $u$  belong to  $R$ , and so its domination requirement is satisfied. For each node  $v \in L_1$ ,  $|N(v) \cap R| = f_v - 1$ , and for any node  $v \in (\cup_{z \in L_1} \bar{N}(u, z)) \setminus L_1$ ,  $|N(v) \cap R| = d_v$ , and so the domination requirements are satisfied for these nodes too. So, the node sets  $R$  and  $R \cup \{w\}$  are  $f$ -tuple dominating sets, and since their incidence  
 420 vectors satisfy (5) with equality (and thus also  $a^T x = b$ ), we deduce  $a_w = 0$ .

Let  $w \in V \setminus (\mathcal{S} \cup Z)$ . Let  $z$  denote the node in  $\mathcal{S} \cup Z$  which is closest to  $w$  in an elementary chain joining  $w$  and  $u$  in  $G$ . We consider three cases:

- if  $z \in Z$ , then define  $\tilde{R} = (V \setminus \mathcal{S}) \cup L_1$ ,
- if  $z \in \bar{N}(u, \hat{z}) \setminus \{\hat{z}\}$  with  $\hat{z} \in L_1$ , then define  $\tilde{R} = (V \setminus \mathcal{S}) \cup (L_1 \setminus \{\hat{z}\}) \cup \{z\}$ ,

- if  $z \in L_0 \cup L_1$ , then define  $\tilde{R} = (V \setminus \mathcal{S}) \cup \{z, u\} \cup X$ , where  $X$  denote a set of exactly  $f_u - |Z| - 2$  neighbors of  $u$  different from  $z$ .

Using Assumption B, the sets  $\tilde{R}$  and  $\tilde{R} \setminus \{w\}$  are  $f$ -tuple dominating sets. And since their incidence vectors satisfy (5) with equality, we deduce  $a_w = 0$ .

Consider now a node  $w \in L_0 \cup L_1$ . Let  $X$  denote a set of  $f_u - |Z| - 1$  neighbors of  $u$  in  $N(u) \setminus Z$  including node  $w$ . Let  $\hat{R} = (V \setminus \mathcal{S}) \cup \{u\} \cup X$ . Let  $w'$  denote any neighbor of  $u$  not in  $\hat{R}$ . Then the sets  $\hat{R}$  and  $\hat{R} \Delta \{w, w'\}$  are both  $f$ -tuple dominating sets in  $G$  whose incidence vectors satisfy (5) with equality, thus implying  $a_w = a_{w'}$ . In what follows let  $c_1 \geq 0$  denote the value such that  $a_w = c_1$ , for all  $w \in L_0 \cup L_1$ .

Let  $w \in \mathcal{S} \setminus (L_0 \cup L_1 \cup \{u\})$ . So  $w$  belongs to a set of the form  $\overline{N}(u, \bar{w})$  for some node  $\bar{w} \in L_1$ . So we have  $|\overline{N}(u, \bar{w})| \geq 2$ , and thus  $f_w \leq d_w - 1$  (from the assumptions into the statement of the proposition). Let  $R = (L_1 \setminus \{\bar{w}\}) \cup (V \setminus \mathcal{S}) \cup \{w\}$ . Since  $R$  and  $R \Delta \{w, \bar{w}\}$  are  $f$ -tuple dominating sets whose incidence vectors satisfy (5) with equality, we deduce  $a_w = a_{\bar{w}} = c_1$ .

Finally, consider the sets  $R_1 = L_1 \cup (V \setminus \mathcal{S})$  and  $R_2 = (V \setminus \mathcal{S}) \cup \{u\} \cup X$ , where  $X$  stands for a set of  $f_u - |Z| - 1$  nodes in  $N(u) \setminus Z$ . Since the sets  $R_1$  and  $R_2$  are  $f$ -tuple dominating sets in  $G$  whose incidence vectors satisfy (5) with equality, we deduce

$$a^T \chi^{R_1} = |L_1|c_1 = b = a^T \chi^{R_2} = a_u + (f_u - 1 - |Z|)c_1.$$

It follows that the inequality  $a^T x \geq b$  corresponds to (5), up to multiplication by a positive scalar.  $\square$

#### 4.2. Separation of extended neighborhood inequalities

**With respect to** the separation problem associated with the family of extended neighborhood inequalities (5), we have the next result.

**Proposition 4.4.** *Let  $G = (V, E)$  denote an undirected simple graph, and  $f \in \mathcal{F}_G$ . For a fixed nonnegative integer  $k$ , the separation problem **with respect to** the family of inequalities (5) such that  $|Z| = k$ , can be solved in polynomial time.*

435 *Proof.* Let  $x^*$  denote the point that is given as input for the separation problem. Let  $\mathcal{A}$  denote the set of nodes  $u \in V$ , satisfying  $f_u \geq k + 1$ , and  $|\{v \in N(u) : f_v \geq 1\}| \geq f_u - k$ . (The set  $\mathcal{A}$  can be determined in polynomial time). Assume  $\mathcal{A}$  is nonempty, since otherwise no inequality (5) with  $|Z| = k$  is violated.

440 For each node  $u \in \mathcal{A}$  and each node subset  $Z$  of exactly  $k$  nodes among the neighbors of  $u$ , we proceed as follows. (For fixed  $k$ , the number of such sets  $Z$  is polynomial.) Let  $\widehat{L}_1 \subseteq N(u)$  stand for the neighbors of  $u$  that are candidates for belonging to the set  $L_1$ , i.e.  $\widehat{L}_1 = \{v \in N(u) \setminus Z : f_v \geq 1\}$ . In case  $|\widehat{L}_1| < f_u - |Z|$ , then, no inequality (5) for the considered set  $Z$  exists, so  
 445 assume that  $|\widehat{L}_1| \geq f_u - |Z|$ . For each node  $z \in \widehat{L}_1$ , let  $\overline{N}(u, z) = \{z\} \cup \overline{Q}_z$  with  $\overline{Q}_z$  consisting of the nodes in  $N(z) \setminus \{u\}$  which correspond to the  $d_z - f_z$  smallest values among  $\{x_v^* : v \in N(z) \setminus \{u\}\}$  (breaking ties arbitrarily). Then, let  $\overline{L}_1 = \{z \in \widehat{L}_1 : x_u^* + \sum_{v \in \overline{N}(u, z) \setminus \{z\}} x_v^* < 1\}$ . If  $|\overline{L}_1| \geq f_u - |Z|$ , set  $L_1 = \overline{L}_1$ . Otherwise, define  $L_1$  as the set of nodes corresponding to the  $f_u - |Z|$  smallest  
 450 values in the set  $\{\sum_{v \in \overline{N}(u, z) \setminus \{z\}} x_v^* : z \in \widehat{L}_1\}$  (breaking ties arbitrarily). Then, set  $L_0 = N(u) \setminus (Z \cup L_1)$ .

Observe that the inequality (5) may be rewritten in the following form, in which, fixing  $u, Z$  and  $x = x^*$ , the first two summands in the left-hand side do not depend on the set  $L_1$ .

$$(|Z|+1-f_u)x_u + \left( \sum_{v \in N(u) \setminus Z = L_0 \cup L_1} x_v \right) + \sum_{w \in L_1} \left( x_u - 1 + \sum_{v \in \overline{N}(u, w) \setminus \{w\}} x_v \right) \geq 0.$$

It follows that, for fixed  $u, Z$ , the tripartition  $(Z, L_0, L_1)$  determined above corresponds to an inequality of type (5) having maximum violation.  $\square$

From Proposition 4.4, it follows that for graphs having a maximum degree  
 455 bounded by a fixed constant the separation problem [with respect to](#) all the inequalities of the type (5) can be solved in polynomial time. Then, from the equivalence between optimization and separation [18], it follows that for such graphs the relaxation of  $[MW_f]$  obtained by adding the inequalities (5) to  $(LP1)$

can be solved in polynomial time and may lead to a better bound on the optimal  
 460 objective value of (IP1) (than the linear relaxation of the latter).

### 4.3. About the 2-tuple dominating set polytope for trees

The conjecture made by Argiroffo (see Section 3 in [2]) on the formulation  
 of the 2-dominating set polytope of trees (i.e. the  $f$ -tuple dominating set poly-  
 tope of trees for the particular case when  $f_v = 2$ , for all  $v \in V$ ) stated that  
 465 a complete formulation of the 2-tuple dominating set polytope was given by a  
 set of inequalities, each one having a support included in the closed neighbor-  
 hood of a single node. Consider the graph  $G'$  of Figure 5(a), where the node  
 domination requirements  $(f'_v)_{v \in V}$  correspond to the values close to the nodes.  
 By Proposition 4.3 the inequality  $2x_1 + x_2 + x_3 + x_4 + x_5 + x_7 + x_8 \geq 3$  is  
 470 facet-defining for  $\mathcal{U}_{G'}^{f'}$ . It follows that Argiroffo's conjecture does not hold: the  
 instance illustrated in Figure 5(b) provides a counterexample since a complete  
 formulation of  $\mathcal{U}_G^f$  can be obtained by adding to the one of the instance from  
 Figure 5(a), the set of equations  $x_v = 1$ , for all  $v \in N[\mathcal{R}]$ .

Figure 5: Illustrations for a facet-defining inequality of type (5)

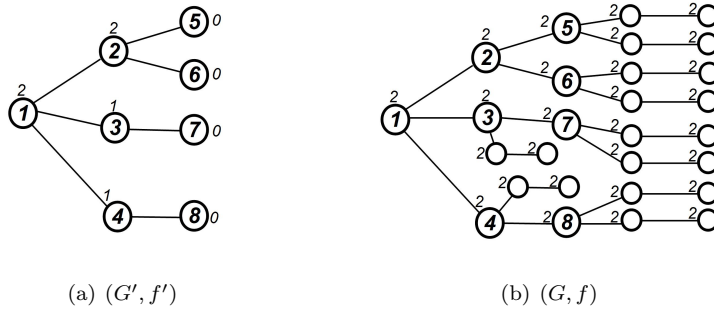

## 5. Decomposition result and extended formulation

### 5.1. Decomposition result

Let  $G = (V, E)$  stand for a connected graph (extending the results to the  
 non connected case is straightforward), and let  $f \in \mathcal{F}_G$ . Assume that there

exists a node  $u \in V$  such that all its neighbors belong to different connected components in  $G[V \setminus \{u\}]$ . Let  $N(u) = \{w_1, w_2, \dots, w_p\}$  and denote by  $W^i$  the node set of the connected component in  $G[V \setminus \{u\}]$  that contains  $w_i$ . For each  $i \in \{1, 2, \dots, p\}$ , let  $G^i = (V^i, E^i) = G[W^i \cup \{u\}]$ , and define  $f^i \in \mathcal{F}_{G^i}$  as follows:  $f_u^i = 0$ , and  $f_v^i = f_v$ , for all  $v \in W^i$ . Given a vector  $x \in \mathbb{R}^V$ , let  $x^i$  stand for its restriction to the entries indexed on  $V^i$ .

The next proposition is analogous to a decomposition property established with respect to  $f$ -total dominating set polytopes (see Section 3 in [11]). The proof can be done similarly and is thus omitted.

**Proposition 5.1.** *Let  $\alpha \in \{0, 1\}$ . Then, resuming the notation introduced above, the polytope  $Q^\alpha$  defined by*

$$Q^\alpha = \left\{ x \in \mathbb{R}^V : x^i \in \mathcal{U}_{G^i}^{f^i}, i = 1, \dots, p, x_u = \alpha \text{ and } \sum_{v \in N[u]} x_v \geq f_u \right\}$$

is integral.

From Proposition 5.1 and Balas' work [5], an extended formulation of  $\mathcal{U}_G^f$  can be simply determined provided that complete formulations are known for  $\mathcal{U}_{G^i}^{f^i}$ , for all  $i \in \{1, 2, \dots, p\}$ . More precisely, resuming the notation from Proposition 5.1, we have

$$\mathcal{U}_G^f = \left\{ x \in \mathbb{R}^V \left| \begin{array}{l} x = y^0 + y^1, \\ A^0 y^0 \geq \lambda b^0, A^1 y^1 \geq (1 - \lambda) b^1, \\ \lambda \in [0, 1], (y^0, y^1) \in \mathbb{R}^V \times \mathbb{R}^V \end{array} \right. \right\}.$$

where  $A^\alpha, b^\alpha$  define a complete formulation of the polytope  $Q^\alpha$ :  $Q^\alpha = \{x \in \mathbb{R}^V : A^\alpha x \geq b^\alpha\}$ , for  $\alpha = 0, 1$ .

This feature is used in what follows to obtain an extended formulation of  $\mathcal{U}_G^f$  for the case of trees.

### 5.2. Extended formulation for trees

Assume now that  $G$  stands for a star having for center node 1, and let  $f \in \mathcal{F}_G$ . We mentioned earlier (Section 3) that the number of facets of  $\mathcal{U}_G^f$



could be exponential, depending on the vector  $f$ . Alternatively, a compact extended formulation can be easily obtained. Indeed, observe that

$$\begin{aligned} \mathcal{P}_1^* &= \mathcal{U}_G^f \cap \{x \in \mathbb{R}^V : x_1 = 1\} \\ &= \left\{x \in [0, 1]^V : x_1 = 1 \text{ and } \sum_{v \in V \setminus \{1\}} x_v \geq f_1 - 1\right\}, \text{ and} \\ \mathcal{P}_0^* &= \mathcal{U}_G^f \cap \{x \in \mathbb{R}^V : x_1 = 0\} \\ &= \left\{x \in [0, 1]^V : x_1 = 0, x_v = 1, v \in L_1, \text{ and } \sum_{v \in V \setminus (\{1\} \cup L_1)} x_v \geq f_1 - |L_1|\right\}. \end{aligned}$$

(Recall that  $L_1 = \{v \in V \setminus \{1\} : f_v = 1\}$ .) Given any set  $S$ , let  $\text{conv}(S)$  denote its convex hull. Since  $\mathcal{U}_G^f = \text{conv}(\mathcal{P}_0^* \cup \mathcal{P}_1^*)$ , a compact formulation for stars follows from Balas' results [5]. And iteratively applying Proposition 5.1 together with Balas' results [5], an extended formulation can be obtained for trees.

## 6. Preliminary computational experiments

In this section we report preliminary computational results providing some first indications on the *potential* interest of the star and extended neighborhood inequalities introduced above to improve the bound from (LP1). In fact, from the experiments that [have been done](#) so far, it appears that for arbitrary graphs, cost functions and domination requirements, the new families of inequalities tend to fail to provide improvements over the bound given by the relaxation (LP1). Anyhow, summarizing our observations, improvements in terms of gap closure could be namely observed on sparse graphs containing few nodes with a large degree and most of the nodes with a low degree. With respect to the cost function and the domination requirements, the most favourable cases seem to be those for which part of the nodes of highest degree are assigned with a cost and domination requirement close to their degree halved. The other nodes are set with a (comparatively) low cost and the domination requirement may be arbitrary. The purpose here is not to delve into an extensive computational study of the inequalities introduced in this paper but rather to give a first illustration of these observations and the fact that the new inequalities introduced in this paper can indeed for some instances contribute to improve the bound stemming

515 from  $(LP1)$ . (Also, one may notice that the integrality gap from  $(LP1)$  can be quite large, see namely the case of a star hereafter and Appendix D).

The graphs considered for the reported results are [complete bipartite graphs](#)<sup>2</sup>, and several sparse graphs from the Network Repository [33] corresponding to different applications (see the last reference for further details). (For graphs  
520 containing loops and/or multiple edges, they have been removed to get simple graphs. The number of nodes and edges reported hereafter are those of these simple graphs.) The node costs and domination requirements have been set as follows. Let  $p \in [0, 1]$  and let  $C$  denote the set of the  $\lceil p \cdot |V| \rceil$  nodes of highest degree in  $G$  (breaking ties arbitrarily). Then, for each node  $v \in C$ , we set  
525  $f_v = \lceil \frac{d_v}{2} \rceil$ ,  $w_v = \lfloor \frac{d_v}{2} \rfloor + 1$ . And for each node  $v \in V \setminus C$ , we set  $f_v = w_v = d_v$ .

With respect to the separation procedure that is used to add iteratively inequalities to  $(LP1)$ , we proceed as follows. If the optimal solution of the current relaxation is fractional, we firstly separate [with respect to](#) the star-1 inequalities. If such an inequality is violated, then one with maximum violation  
530 (breaking ties arbitrarily) is added to the current relaxation that is solved again and we iterate. Otherwise (i.e. all the star-1 inequalities are satisfied), we proceed analogously [with respect to](#) the star-2 inequalities. And if no violated star-2 inequality is found, then we apply the following simple heuristic to find a violated extended neighborhood inequality. For each node  $v$  the neighbor nodes  
535 are ordered by decreasing value in the current solution. Then for an increasing value of the cardinality  $k$  of  $|Z|$ , we define  $Z$  as the set of the first  $k$  neighbors of  $v$ . Then, following the proof of Proposition 4.4, we determine if there exists a violated extended neighborhood inequality of the form (5) for this particular set  $Z$ . All the possible values for  $|Z|$  allowed by Proposition 4.2 are considered.  
540 If a violated inequality is found, one with maximum violation is added to the current relaxation (breaking ties arbitrarily).

---

<sup>2</sup>In what follows,  $K_{n,m}$  denotes the complete bipartite graph with partitions of size  $n$  and  $m$ .

Computations are done on a laptop having a 2.3 GHz Intel Core i5 processor and 16 GB of RAM. The linear programs were solved using CPLEX 12.10 with default settings. In our experiments we used  $p \in \{0.25; 0.5; 0.75; 1\}$  and set a  
545 time limit to one hour. Let  $Z^*$  denote the optimal objective value of  $(IP1)$  and  $LB$  the optimal objective value of some relaxation. Then, the optimality gap is computed as  $gap(LB) = \frac{Z^* - LB}{LB} \times 100$ . And given two lower bounds  $LB1, LB2$  on  $Z^*$ , such that  $LB1 \leq LB2$ . The percentage of gap reduction of  $LB2$  over  $LB1$  is computed as  $\frac{gap(LB1) - gap(LB2)}{gap(LB1)} \times 100$ .

550 The results are reported in Table 1. For each instance, we indicate: its name, the number of nodes ( $|V|$ ), the number of edges ( $|E|$ ), the value of  $p$ , the optimal objective value  $Z^*$  of  $(IP1)$ , the time (in seconds) needed to solve  $(IP1)$ , the optimal objective value of  $(LP1)$ , the time needed to solve it and its optimality gap. Then, **with respect to** the application of the cutting-plane procedure described above (denoted by " $LP1 + \star$ ") we indicate: the final optimal  
555 objective value, the time needed, the number of constraints generated (specifying in squared brackets the number of star-1, star2 and extended neighborhood inequalities generated, in this order), the gap, and **then** the gap reduction (GR) **with respect to**  $(LP1)$ . If the processing time exceeds our limit this is indicated  
560 by an asterisk (\*). In particular, if this is the case **with respect to**  $(IP1)$  the value reported in the field "obj" is the objective value of the best feasible solution found within this time constraint and the gaps are computed using this objective value (instead of  $Z^*$ ).

The obtained results clearly point out that for some instances **the families of**  
565 **inequalities introduced in this paper** can substantially contribute to reduce the gap of  $(LP1)$ . **Anyhow, as we already mentioned above, the potential improvements provided by the new families of inequalities are very much dependent on the cost function and the graph structure. The obtained results also display an important diversity in terms of gap reduction. Other experiments have been**  
570 **carried out, e.g., on dense instances from the Network Repository [33], on randomly generated (sparse and dense) graphs using the Erdős-Rényi model and on random regular graphs. But we could not observe improvements in terms**

of gap closure using our new results for such instances. Anyhow, improvements may be observed on some dense graphs with some particular structure (see, e.g.,  
575 the case of  $K_{250,750}$  and  $K_{250,1750}$  in Table 1). We report in Appendix D an auxiliary result about the maximum integrality gap for star graphs and a cost function such as the one used in the experiments (with  $p > 0$ ), showing that it can be close to  $4/3$ . So far, for all the cost functions and graphs that we have considered, the integrality gap was always less than  $4/3$ . This might suggest  
580 that graphs corresponding to the union of high-order stars with few intersections and/or connections between them, together with a cost function such as the one we considered, are among the most promising instances in terms of potential gap reduction in absolute value (i.e. the absolute difference between the gaps corresponding to  $LP1$  and ' $LP1+\star$ ' in Table 1). This seems to be consistent  
585 with the results obtained if we have a closer look at the structure of the graphs, considering namely the degree distribution of the nodes (see Appendix E for some node degree information about the instances reported in Table 1 except for complete bipartite graphs, since this is clear for the latter). A deeper analysis aiming at a characterization of the instances for which the inequalities we  
590 introduced lead to a strict improvement over ( $LP1$ ) is an interesting matter for future research work.

## 7. Conclusion and perspectives

In this paper we proceeded to investigations related to the  $f$ -tuple domination concept from a polyhedral perspective. We introduced families of facet-defining inequalities, provided a complete formulation for stars and disproved  
595 a conjecture from the literature. Some preliminary computational results have also been presented.

Future research work may be directed towards a deeper computational study aiming at determining families of instances for which the inequalities presented  
600 may contribute to improve the bound stemming from  $(LP1)$ . Another line of research is looking for [other families of \(facet defining\) inequalities](#) and a complete formulation of the  $f$ -tuple dominating set polytope in the original space, for trees and other graph classes.

## Acknowledgments

605 [The author wishes to thank the editor and the referees for their insightful comments and suggestions that led to substantial improvements.](#)

## References

- [1] Anstee, R., Farber, M.: Characterizations of totally balanced matrices. *J. Algorithms* 5 (1984) 215-230
- 610 [2] Argiroffo, G.: New facets of the 2-dominating set polytope of trees. *Proceedings of the 11th SIO, Argentina* (2013) 30-34
- [3] Baiou, M., Barahona, F.: The dominating set polytope via facility location. In: *ISCO 2014, LNCS 8596* (2014) 38-49
- [4] Balas, E., Zemel, E.: Graph substitution and set packing polytopes. *Networks* 7 (1977) 267-284  
615
- [5] Balas, E.: Disjunctive programming: properties of the convex hull of feasible points. *Discrete Applied Mathematics* 89 (1998) 1-44

Instance	V	E	p	IP1		LP1			LP1+*				GR (%)
				Z*	time (s)	obj	time (s)	gap (%)	obj	time (s)	constraints	gap (%)	
$K_{1,3999}$	4000	3999	0.25	3.935	2999.5	0.023	33.32	3999	0.078	1 [1/0/0]	0	100	
			0.50	2.917	2999.5	0.023	33.32	3999	0.078	1 [1/0/0]	0	100	
			0.75	2.930	2999.5	0.023	33.32	3999	0.078	1 [1/0/0]	0	100	
			1	2.954	2999.5	0.023	33.32	3999	0.078	1 [1/0/0]	0	100	
$K_{250,750}$	1000	187500	0.25	6.177	187312.999	0.415	0.10	187500.000	114.929	250 [250/0/0]	0	100	
			0.5	4.456	156406.999	0.205	0.06	156468.657	179.495	685 [250/435/0]	0.02	66.67	
			0.75	1.220	141124.000	0.107	0	141124.000	0.107	0 [0/0/0]	0	0	
			1	32.508	93999.501	0.393	0.27	93999.501	11.293	0 [0/0/0]	0.27	0	
$K_{250,1750}$	2000	437500	0.25	67.231	406135.999	1.771	0.09	406447.461	2541.900	714 [250/464/0]	0.01	88.89	
			0.5	30.872	344391.500	0.930	0.03	*344452.963	*	1175 [250/925/0]	0.01	66.67	
			0.75	3.108	329124.000	0.274	0	329124.000	0.274	0 [0/0/0]	0	0	
			1	104.189	219249.501	2.239	0.23	219249.501	58.632	0 [0/0/0]	0.23	0	
1138.bus	1138	1458	0.25	0.216	1431.240	0.010	0.47	1435.33	0.056	17 [10/6/1]	0.19	59.57	
			0.50	3.557	1154.430	0.024	1.43	1161.602	0.261	57 [15/22/20]	0.81	43.35	
			0.75	1019	996.354	0.036	2.27	1002.814	0.344	53 [3/15/35]	1.61	29.07	
			1	50.358	996.354	0.036	2.27	1002.814	0.344	53 [3/15/35]	1.61	29.07	
econ-poli	3915	4119	0.25	*3533	3098.645	0.054	*14.02	3467.840	29.508	1009[257/448/304]	*1.88	86.59	
			0.50	*3448	3012.077	0.057	*14.47	3371.365	41.681	1288 [241/575/472]	*2.27	85.49	
			0.75	*3448	3012.077	0.057	*14.47	3371.365	41.51	1288 [241/575/472]	*2.27	85.49	
			1	*3448	3012.077	0.057	*14.47	3371.365	41.86	1288 [241/575/472]	*2.27	85.49	
ca-Erdos92	5094	7515	0.25	*5976	5122.354	0.524	*16.66	5457.137	104.039	1533 [159/1050/324]	*9.51	42.91	
			0.50	*5811	4935.886	0.576	*17.73	5275.181	176.871	2484 [130/1767/587]	*10.16	42.69	
			0.75	*5815	4935.886	0.576	*17.81	5275.181	177.152	2484 [130/1767/587]	*10.23	42.56	
			1	*5815	4935.886	0.576	*17.81	5275.181	175.118	2484 [130/1767/587]	*10.23	42.56	
california	6175	15969	0.25	*12840	12538.024	2.416	*2.41	12730.546	127.845	1164[165/999/0]	*0.86	63.31	
			0.50	*10927	10054.536	8.309	*8.67	10198.013	214.856	1184[86/945/153]	*7.15	17.53	
			0.75	*10345	9389.472	10.239	*10.17	9495.608	286.787	1134 [44/585/505]	*8.94	12.09	
			1	*10361	9389.472	10.325	*10.34	9495.608	285.201	1134 [44/585/505]	*9.11	11.76	
inf-power	4941	6594	0.25	6646	6611.532	0.088	0.52	6626.502	2.561	79 [47/25/7]	0.29	44.23	
			0.50	*5399	5322.590	0.258	*1.43	5345.242	9.276	191 [56/79/56]	*1.00	30.06	
			0.75	*4591	4478.667	0.564	*2.50	4502.458	17.367	206 [23/37/146]	*1.96	21.6	
			1	*4583	4470.942	0.511	*2.50	4495.624	17.103	208 [24/39/145]	*1.94	22.4	

Table 1: Preliminary computational results

- [6] Bianchi, S., Nasini, G., Tolomei, P.: The set covering problem on circulant matrices: polynomial instances and the relation with the dominating set problem on webs. *Electronic Notes in Discrete Mathematics* 36 (2010) 1185-1192
- [7] Bouchakour, M., Contenza, T., Lee, C., Mahjoub, A.: On the dominating set polytope. *European Journal of Combinatorics* 29 (2008) 652-661
- [8] Conforti, M., Cornuéjols, G., Truemper, K.: From totally unimodular to balanced  $0, \pm 1$  matrices: a family of integer polytopes. *Math. Oper. Res.* 19 (1994) 21-23
- [9] Cornuéjols, G.: *Combinatorial Optimization: Packing and Covering*. CBMS-NSF Regional Conference Series in Applied Mathematics CBMS 74, SIAM, Philadelphia, PA (2001)
- [10] Dell'Amico, M., Neto, J.: On  $f$ -domination: polyhedral and algorithmic results. *Mathematical Methods of Operations Research* 90 (2019) 1-22
- [11] Dell'Amico, M., Neto, J.: On total  $f$ -domination: polyhedral and algorithmic results. *Discrete Applied Mathematics* 258 (2019) 97-104
- [12] Dobson, M.P., Leoni, V., Nasini, G.: Arbitrarily limited packings in trees. II MACI (2009)
- [13] Dobson, M.P., Leoni, V., Nasini, G.: The multiple domination and limited packing problems in graphs. *Information Processing Letters* 111 (2011) 1108-1113
- [14] Farber, M.: Domination, independent domination, and duality in strongly chordal graphs. *Discrete Applied Mathematics* 7 (1984) 115-130
- [15] Gagarin, A.: Improved upper bounds for the  $k$ -tuple domination number. *Australasian journal of combinatorics* 41 (2008) 257-261
- [16] Gallant, R., Gunther, G., Hartnell, B., Rall, D.: Limited Packings in Graphs. *Electronic Notes in Discrete Mathematics* 30 (2008) 15-20

- 645 [17] Gallant, R., Gunther, G., Hartnell, B., Rall, D.: Limited Packings in Graphs. *Discrete Applied Mathematics* 158 (2010) 1357-1364
- [18] Grötschel, M., Lovász, L., Schrijver, A.: The ellipsoid method and its consequences in combinatorial optimization, *Combinatorica* 1:2 (1981) 169-197
- 650 [19] Grünbaum, B.: *Convex Polytopes*. Graduate Texts in Mathematics, Vol. 221, Springer. Second Edition (2003)
- [20] Harary, Y., Haynes, T.W.: The  $k$ -tuple domatic number of a graph. *Math. Slovaca* 48 (1998) 161-166
- [21] Harary, Y., Haynes, T.W.: Double domination in graphs. *Ars Combin.* 55  
655 (2000) 201-213
- [22] Haynes T.W., Hedetniemi S.T., Slater J.B. *Fundamentals of Domination in Graphs*, Marcel Dekker (1998)
- [23] Haynes T.W., Hedetniemi S.T., Slater J.B. *Domination in Graphs: Advanced topics.*, Marcel Dekker (1998)
- 660 [24] Hedetniemi, S., Hedetniemi, S., Laskar, R.: Domination in trees: models and algorithms. In: *Graph Theory with Applications to Algorithms and Computer Science*, John Wiley & Sons, New York, 1985, p. 423-442
- [25] Klasing, R., Laforest, C.: Hardness results and approximation algorithms of  $k$ -tuple domination in graphs. *Information Processing Letters* 89 (2004)  
665 75-83
- [26] Leoni, V., Nasini, G.: Limited Packing and Multiple Domination problems: Polynomial time reductions. *Discrete Applied Mathematics* 164 (2014) 547-553
- [27] Liao, C.S., Chang, G.J.: Algorithmic aspect of  $k$ -tuple domination in  
670 graphs. *Taiwanese Journal of Mathematics* 6 (3) (2002) 415-420



- [28] Liao, C.S., Chang, G.J.:  $k$ -tuple domination in graphs. Information Processing Letters 87 (2003) 45-50
- [29] Mahjoub, A.R.: Le polytope des absorbants dans une classe de graphe à seuil. Annals of Discrete Mathematics 17 (1983) 443-452
- 675 [30] Naddef, D.: The Hirsh Conjecture is true for  $(0, 1)$ -polytopes. Mathematical Programming 45 (1989) 109-110
- [31] Padberg, M.W.: On the facial structure of set packing polyhedra. Mathematical Programming 5 (1973) 199-215
- [32] Rautenbach, D., Volkmann, L.: New bounds on the  $k$ -domination number and the  $k$ -tuple domination number. Appl. Math. Lett. 20 (2007) 98-102
- 680 [33] Rossi R.A., Ahmed N.K.: The Network Data Repository with Interactive Graph Analytics and Visualization. In Proceedings of the Twenty-Ninth AAAI Conference on Artificial Intelligence (2015)  
<http://networkrepository.com>
- 685 [34] Shang, W., Wan, P., Yao, F., Hu, X.: Algorithms for minimum  $m$ -connected  $k$ -tuple dominating set problem. Theoretical Computer Science 381 (2007) 241-247
- [35] Stracke, C., Volkmann, L.: A new domination conception. J. Graph Theory 17 (1993) 315-323
- 690 [36] Xu, G., Kang, L., Shan, E., Yan, H.: Proof of a conjecture on  $k$ -tuple domination in graphs. Appl. Math. Lett. 21 (2008) 287-290
- [37] Ziegler, G.M.: Lectures on Polytopes. Graduate Texts in Mathematics 152. Springer-Verlag New York Berlin Heidelberg. Revised edition (1998)
- [38] Zverovich, V.: On general frameworks and threshold functions for multiple domination. Discrete Mathematics 338 (2015) 2095-2104
- 695

## Appendix A. Proofs of Section 2

### Proof of Proposition 2.1

Trivially,  $\dim(\mathcal{U}_G^f) \leq |V| - |N[\mathcal{R}]|$ , since for each node  $v \in N[\mathcal{R}]$  the equation  
700  $x_v = 1$  holds for any vector  $x \in \mathcal{U}_G^f$ . To conclude, we can notice that the  
incidence vectors of the following node subsets are affinely independent and  
they all belong to  $\mathcal{U}_G^f$ :  $V$  and  $V \setminus \{v\}$ , for all  $v \in V \setminus N[\mathcal{R}]$ .  $\square$

### Proof of Proposition 2.2

For  $\sigma \in \{0, 1\}$  and  $v \in V$ , let  $F_v^\sigma$  denote the face of  $\mathcal{U}_G^f$  defined by:  $F_v^\sigma =$   
705  $\mathcal{U}_G^f \cap \{x \in \mathbb{R}^V : x_v = \sigma\}$ .

(i) [ $\Leftarrow$ ] Assume that  $f_v \leq d_v - 1$ , for all  $v \in N[u]$ . Then, the incidence vectors  
(in  $\mathbb{R}^V$ ) of the following node subsets are affinely independent and they all  
belong to  $F_u^0$ :  $V \setminus \{u\}$  and  $V \setminus \{u, v\}$ , for all  $v \in V \setminus \{u\}$ .

[ $\Rightarrow$ ] If  $f_w = d_w$  for some node  $w \in N(u)$ , then  $F_u^0 \subset F_w^1$ , and thus  $x_u \geq 0$   
710 cannot define a facet of  $\mathcal{U}_G^f$ . If  $f_u = d_u$ , then  $F_u^0 \subseteq F_w^1$ , for all  $w \in N(u)$ .

(ii) The inequality is valid for  $\mathcal{U}_G^f$  and the incidence vectors in  $\mathbb{R}^V$  of all the  
following node subsets are affinely independent and belong to  $F_u^1$ :  $V$  and  
 $V \setminus \{v\}$ , for all  $v \in V \setminus \{u\}$ .  $\square$

### Proof of Proposition 2.3

The property that  $|S| \geq 2$  is trivial. Then, assume, for a contradiction, that  
there exists some node  $w \in V$  with  $a_w < 0$ . Let  $D$  denote an  $f$ -tuple dominating  
set such that  $w \notin D$  and  $a^T \chi^D = b$ . Since  $\widehat{D} = D \cup \{w\}$  is an  $f$ -tuple dominating  
720 set and  $a^T \chi^{\widehat{D}} < b$  we get a contradiction with the validity of the inequality  
 $a^T x \geq b$ . And since this inequality is assumed to be a non trivial one, necessarily  
 $b > 0$ .  $\square$

Proof of Proposition 2.4

725 The following node subsets are  $f$ -tuple dominating sets and their incidence vectors are affinely independent:  $V \setminus \{u, w\}$  for all  $w \in V \setminus N[u]$ , and  $V \setminus \{v\}$ , for all  $v \in N[u]$ .  $\square$

**Appendix B. Proofs of Section 3**

Proof of Proposition 3.2

730

Let  $a^T x \geq b$  represent the inequality (2), and let  $S$  denote an  $f$ -tuple dominating set in  $G$ . Consider then the two cases:

- If  $u \notin S$ , then we must have  $L_1 \subseteq S$ . Also  $S$  must contain at least  $f_u$  neighbors of node  $u$  (due to the domination requirement for this node).
- 735 • If  $u \in S$ , then  $S$  must contain  $f_u - 1$  neighbors of node  $u$ .

Thus, in both cases one can easily check that the inequality  $a^T \chi^S \geq b$  holds.  $\square$

Proof of Proposition 3.5

740 Let  $a^T x \geq b$  represent the inequality (3), and let  $S$  denote an  $f$ -tuple dominating set in  $G$ . Consider then the two cases:

- If  $u \notin S$ , then we must have  $L_1 \subseteq S$ .
- If  $u \in S$ , then  $S$  must contain  $f_u - 1$  neighbors of node  $u$ , and thus at least  $f_u - 1 - |Z|$  nodes in  $L_1 \cup (L_0 \setminus Z)$ .

So in both cases we deduce that the inequality  $a^T \chi^S \geq b$  holds.  $\square$

We firstly show that  $a_v > 0$ , for all  $v \in L_1$ . Assume, for a contradiction, that there exists some node  $z \in L_1$ , such that  $a_z = 0$ . Since  $a^T x \geq b$  is assumed to be different from the trivial inequalities, there exists an  $f$ -tuple dominating set  $D$  such that  $a^T \chi^D = b$  and  $z \notin D$ . The fact that  $z \notin D$  implies  $1 \in D$ . And given  
750 that  $D \setminus \{v\} \cup \{z\}$  is an  $f$ -tuple dominating set, for all  $v \in D \setminus \{1\}$ , we must have  $a_v = 0$ , for all  $v \in D \setminus \{1\}$ . This also implies  $b = a_1 > 0$  and  $a_v = 0$ , for all  $v \in L_1$ . (If there exists  $w \in L_1$  such that  $a_w > 0$ , since  $a^T x \geq b$  is assumed to be different from  $x_w + x_1 \geq 1$ , there must exist some  $f$ -tuple dominating set  $\widehat{D}$  such that  $a^T \chi^{\widehat{D}} = b$  and  $\{1, w\} \subseteq \widehat{D}$ . But then,  $a^T \chi^{\widehat{D}} > b = a_1$ , a contradiction.)  
755 Now, let  $\widetilde{D}$  denote an  $f$ -tuple dominating set not containing node 1 and such that  $a^T \chi^{\widetilde{D}} = b$ . Then, necessarily  $L_1 \subseteq Z_0 \subset \widetilde{D}$  and  $|Z_0| < f_1$  (since otherwise  $b = 0$  and  $a^T x \geq b$  is redundant [with respect to](#) trivial inequalities). This implies that, for any  $f$ -tuple dominating set  $D$  such that  $a^T \chi^D = b$ , we must  
760 have  $Z_0 \subset D$ . Thus the face of  $\mathcal{U}_G^f$  defined by  $a^T x \geq b$  is contained in the face  $\cap_{v \in Z_0} F_v^1$  with  $F_v^1 = \mathcal{U}_G^f \cap \{x \in \mathbb{R}^n : x_v = 1\}$ , a contradiction.

We now show that  $a_v = \alpha$ , for all  $v \in L_1$ , for some positive real value  $\alpha$ . Let  $z \in L_1$  such that  $a_z = \min_{v \in L_1} a_v$ . Let  $D$  denote an  $f$ -tuple dominating set such that  $a^T \chi^D = b$  and  $z \notin D$ . Assume that there exists  $w \in L_1$  such that  $a_w > a_z$ .  
765 Necessarily  $1 \in D$  (for the domination of the node  $z \in L_1 \setminus D$ ) and  $a_z \geq a_v$ , for all  $v \in D \setminus \{1\}$  (since otherwise we get a contradiction with the validity of the inequality  $a^T x \geq b$ ). So, in particular,  $w \notin D$ . Now, let  $\widehat{D}$  stand for an  $f$ -tuple dominating set such that  $a^T \chi^{\widehat{D}} = b$  and  $\{1, w\} \subseteq \widehat{D}$ . (The existence of such a set  $\widehat{D}$  follows from the assumption that the inequality  $a^T x \geq b$  is different from  
770  $x_1 + x_w \geq 1$ .) Then, necessarily  $a_v \geq a_w$ , for all  $v \in V \setminus \widehat{D}$ . But the latter implies  $D \cup \{z\} \subset \widehat{D}$ , a contradiction since then  $a^T \chi^{\widehat{D}} > a^T \chi^D = b$ .  $\square$

Proof of Claim 2 (in the proof of Proposition 3.9)

775 Consider firstly the case  $|L_1| \leq f_1$ . Then for any  $f$ -tuple dominating set  $D$  such that  $a^T \chi^D = b$ , the equation  $|D| = f_1$  also holds: the face defined by  $a^T x \geq b$  is contained in the one defined by the inequality (2).

So assume now that  $|L_1| > f_1$ . Note that in this case there is a single  $f$ -tuple dominating set not containing node 1 and whose incidence vector satisfies the equation  $a^T x = b$ :  $L_1$ . If  $L_0 = \emptyset$ , then the result follows from Claim 1. So  
780 assume that  $L_0 \neq \emptyset$  and let  $\bar{D}$  stand for an  $f$ -tuple dominating set satisfying  $a^T \chi^{\bar{D}} = b$  and  $\bar{w} \in \bar{D}$  with  $\bar{w} \in L_0$  such that  $a_{\bar{w}} = \max_{v \in L_0} a_v$ . Necessarily  $1 \in \bar{D}$  (since otherwise  $L_1 \subset \bar{D}$  and removing node  $\bar{w}$  from  $\bar{D}$  we obtain an  $f$ -tuple dominating set contradicting the validity of  $a^T x \geq b$ ). Also, observe  
785 that  $|\bar{D}| = f_1$  and there exists some node  $z \in L_1 \setminus \bar{D}$ . Considering then the  $f$ -tuple dominating set  $\bar{D} \Delta \{\bar{w}, z\}$ , we deduce (resuming the notation of Claim 1)  $a_z = \alpha \geq a_{\bar{w}}$ , where for any two sets  $A, B$ , the notation  $A \Delta B$  stands for their symmetric difference  $(A \cup B) \setminus (A \cap B)$ .

Assume now that there exists some node  $\hat{w} \in L_0$  such that  $a_{\hat{w}} < \alpha$ . Since the  
790 inequality  $a^T x \geq b$  is assumed to be different from the neighborhood inequalities of the nodes in  $L_1$ , for any node  $z \in L_1$  there must exist an  $f$ -tuple dominating set  $D$  satisfying  $a^T \chi^D = b$  and  $\{1, z\} \subseteq D$ . This namely implies  $|Q| < f_1 - 1$  with  $Q = \{v \in L_0 : a_v < \alpha\}$  (since otherwise we get a contradiction with the validity of the inequality  $a^T x \geq b$ ).

795 It follows that if  $\hat{D}$  is an  $f$ -tuple dominating set whose incidence vector satisfies  $a^T x = b$ , then either:

- $1 \in \hat{D}$ . And in that case, necessarily  $Q \subset \hat{D}$  (since otherwise, by exchanging a node in  $\hat{D} \setminus \{1\}$  with a node in  $Q$ , we get a contradiction with the validity of  $a^T x \geq b$ ).
- 800 • Or  $1 \notin \hat{D}$ . Then necessarily  $\hat{D} = L_1$  (to satisfy the domination requirements of the nodes in  $L_1$ ), using the fact that  $Z_0 = \emptyset$  together with  $|L_1| > f_1$ .

It then follows that the equation  $x_1 = x_{\hat{w}}$  must be satisfied by the incidence vectors of all the  $f$ -tuple dominating sets satisfying  $a^T x = b$ . Given that the polytope  $\mathcal{U}_G^f$  is full dimensional, this would imply that the face defined by  $a^T x \geq b$  would be contained in a face defined by an inequality of the form  $x_{\hat{w}} \geq x_1$  or  $x_{\hat{w}} \leq x_1$ , both of which are not valid for  $\mathcal{U}_G^f$ , a contradiction.  $\square$

Proof of Claim 3 (in the proof of Proposition 3.9)

810

We firstly show  $L_1 \neq \emptyset$ . If  $L_1 = \emptyset$ , then one can easily check that  $\mathcal{U}_G^f = \{x \in [0, 1]^V : \sum_{v \in V} x_v \geq f_1\}$  (so for the only non trivial facet defining inequality we have  $Z_0 = \emptyset$ ).

We now show  $|Z_0| < f_1 - 1$ . Assume, for a contradiction, that  $|Z_0| \geq f_1 - 1$ . Then, necessarily  $b = a_1$  and, from Claim 1, there does not exist any  $f$ -tuple dominating set  $D$  satisfying both  $a^T \chi^D = b$  and  $\{1, w\} \subseteq D$  for any node  $w \in L_1$ .

We finally show  $f_1 - |L_1| < |Z_0|$ . Assume, for a contradiction that  $|L_1| + |Z_0| \leq f_1$  and let  $D$  stand for any  $f$ -tuple dominating set whose incidence vector satisfies  $a^T x = b$ . Then either

- $1 \notin D$ . Then, necessarily  $L_1 \subset D$  (to comply with the domination requirements of the nodes in  $L_1$ ) and  $|D \setminus L_1| \geq f_1 - |L_1|$  to comply with the domination requirement of node 1. If  $Z_0$  was not contained in  $D$ , then it would be possible to exchange a node  $v$  from  $D \setminus L_1$  such that  $a_v > 0$  with a node in  $Z_0$  to obtain an  $f$ -tuple dominating set violating the inequality  $a^T x \geq b$ .
- $1 \in D$ . Since  $|Z_0| < f_1$  we must have  $Z_0 \subset D$  since otherwise it would be possible to exchange a node  $v \in D \setminus \{1\}$  such that  $a_v > 0$  with a node in  $Z_0$  to get an  $f$ -tuple dominating set violating the inequality  $a^T x \geq b$ .

It follows that the face of  $\mathcal{U}_G^f$  defined by  $a^T x \geq b$  is contained in the one defined by  $x_v \leq 1$ , for any  $v \in Z_0$ , a contradiction.  $\square$

Proof of Claim 4 (in the proof of Proposition 3.9)

835 Firstly, note that if  $L_0 \subseteq Z_0$ , then the result holds by Claim 1. So assume from now on that  $L_0 \setminus Z_0 \neq \emptyset$ . Notice that by Claim 3 we have  $L_1 \neq \emptyset$ . Let  $w \in L_0$  such that  $a_w = \max_{v \in L_0} a_v$ . Let  $D$  denote an  $f$ -tuple dominating set such that  $w \in D$  and  $a^T \chi^D = b$ . Necessarily,  $1 \in D$  (since otherwise  $L_1 \subset D$ , and by Claim 3,  $\widehat{D} = L_1 \cup Z_0$  is an  $f$ -tuple dominating set satisfying  $a^T \chi^{\widehat{D}} < a^T \chi^D$ ).  
840 Also, there must exist some node  $z \in L_1 \setminus D$ . And since  $D \Delta \{w, z\}$  is an  $f$ -tuple dominating set, we deduce  $a_z = \alpha \geq a_w$ .

Now, assume, for a contradiction, that there exists some node  $\bar{w} \in B$ , with  $B = \{v \in L_0 : 0 < a_v < \alpha\}$ . Let  $\overline{D}$  stand for an  $f$ -tuple dominating set in  $G$  such that  $a^T \chi^{\overline{D}} = b$ . We have the following two cases.

- 845 • Case 1:  $1 \notin \overline{D}$ . Then, necessarily  $L_1 \subseteq \overline{D}$ . By Claim 1  $L_1 \cap Z_0 = \emptyset$  and then, by Claim 3  $|L_1 \cup Z_0| > f_1$ . It follows that  $\bar{w} \notin \overline{D}$ .
- Case 2:  $1 \in \overline{D}$ . Note that since  $a^T x \geq b$  is assumed to be different from the neighborhood inequalities of the nodes in  $L_1$ , for each node  $z \in L_1$ , there exists an  $f$ -tuple dominating set  $\widehat{D}_z$  such that  $a^T \chi^{\widehat{D}_z} = b$  and  $\{1, z\} \subseteq \widehat{D}_z$ .  
850  $\widehat{D}_z$ . But then, necessarily, for any such set  $\widehat{D}_z$  we must have  $B \subset \widehat{D}_z$  (since otherwise we get a contradiction with the validity of  $a^T x \geq b$ ), thus implying  $|B| \leq f_1 - 2 - |Z_0|$ . It follows that for any  $f$ -tuple dominating set  $D'$  containing 1 and such that  $a^T \chi^{D'} = b$  we must have  $B \subset D'$ . So we deduce for this case that  $\bar{w} \in \overline{D}$ .

855 The two cases above imply that the equations  $x_1 = x_z$ , for all  $z \in B$ , are satisfied by all the incidence vectors of the  $f$ -tuple dominating sets satisfying  $a^T x \geq b$  with equality. And since the polytope  $\mathcal{U}_G^f$  is full dimensional, this also implies that the face defined by the inequality  $a^T x \geq b$  is contained in a face defined by an inequality of the form  $x_1 \geq x_z$  or  $x_1 \leq x_z$ , both of which are not

860 valid for  $\mathcal{U}_G^f$ , a contradiction.  $\square$

## Appendix C. Proofs of Section 4

### Proof of Proposition 4.2

865 Let  $D$  denote any  $f$ -tuple dominating set in  $G$ . If  $u \notin D$ , necessarily  $D \cap \bar{N}(u, w) \geq 1$  for each node  $w \in L_1$  (so as to satisfy the domination requirement  $f_w$  of node  $w$ ). If  $u \in D$ , then necessarily  $|D \cap (L_1 \cup L_0)| \geq f_u - 1 - |Z|$  (so as to satisfy the domination requirement  $f_u$  of node  $u$ ). In both cases  $\chi^D$  satisfies (5).  $\square$

## 870 Appendix D. Auxiliary result on the integrality gap of (LP1) for stars

In this appendix, we address the relevance of the inequalities (2)-(3) from an *optimization point of view* by considering the integrality gap of the formulation (LP1) for the case when  $G$  is a star and the weight function corresponds to the  
 875 left-hand side of a facet-defining inequality not present in formulation (IP1). We consider hereafter the case of an inequality of the type (2). The same result can be shown to hold if we consider a weight function corresponding to an inequality of type (3).

**Proposition D.1** *Let  $G = (V, E)$  denote a star having for center node 1,  $n \geq 3$ .  
 880 Let  $f \in \mathcal{F}_G$ ,  $L_1 = \{v \in V \setminus \{1\} : f_v = 1\}$ ,  $L_0 = V \setminus (\{1\} \cup L_1)$ , and let  $\hat{w} \in \mathbb{R}^n$  be defined as follows:  $\hat{w}_1 = \max(|L_1|, f_1) - f_1 + 1$ , and  $\hat{w}_v = 1$ , for all  $v \in V \setminus \{1\}$ . Then, the integrality gap of (LP1) with an objective function corresponding to  $\hat{w}$  is upper bounded by  $\frac{4}{3}$  and this bound is asymptotically tight.*

*Proof.* For the case when  $f_1 \leq 1$  or  $f_1 \geq |L_1|$ , the objective values of (IP1) and (LP1) coincide. So assume from now on that  $2 \leq f_1 < |L_1|$ . Then, notice that the node set  $L_0$  has no incidence on the optimal objective value of (LP1).



Indeed, given the assumption  $|L_1| > f_1$ , if  $x^*$  denotes any optimal solution of (LP1) with  $x_u^* > 0$  for some node  $u \in L_0$ , then we can easily determine another optimal solution  $\widehat{x}^*$  satisfying  $\widehat{x}_u^* = 0$ , for all  $u \in L_0$  (decreasing positive entries of  $x^*$  indexed on  $L_0$  and increasing entries indexed on  $L_1$  that are lower than 1). So, in what follows and to simplify the presentation, we shall assume  $L_0 = \emptyset$  and thus  $|L_1| = n - 1$ .

Consider the dual problem to (LP1):

$$(D1) \left\{ \begin{array}{l} \max \quad \sum_{v \in V} (f_v y_v - z_v) \\ s.t. \\ \sum_{u \in N[v]} y_u - z_v \leq \widehat{w}_v, v \in V, \\ y, z \in \mathbb{R}_+^n. \end{array} \right.$$

Let  $\vec{0}$  stand for the  $n$ -dimensional zero vector. The vector  $(\bar{y}, \vec{0}) \in (\mathbb{R}_+^n)^2$  defined as follows is feasible for (D1):  $\bar{y}_1 = \frac{f_1 - 1}{n - 2}$ ,  $\bar{y}_v = 1 - \bar{y}_1$ , for all  $v \in V \setminus \{1\}$ . A feasible solution to (LP1) is given by the vector  $\bar{x} \in \mathbb{R}^n$  defined as follows:  $\bar{x}_1 = \frac{n - 1 - f_1}{n - 2}$  and  $\bar{x}_v = 1 - \bar{x}_1$ , for all  $v \in V \setminus \{1\}$ . Both  $(\bar{y}, \vec{0})$  and  $\bar{x}$  have the same objective value:  $z(f_1) = \frac{1}{n - 2}[f_1(f_1 - 1) + (n - 1)(n - f_1 - 1)]$ , and are thus optimal.

890

The quantity  $z(\alpha)$  is minimized for  $\alpha \in \{\lceil \frac{n}{2} \rceil, \lfloor \frac{n}{2} \rfloor\}$ , and we get  $z(\frac{n}{2}) = \frac{3n - 2}{4}$  if  $n$  is even and  $z(\lfloor \frac{n}{2} \rfloor) = z(\lceil \frac{n}{2} \rceil) = \frac{(n - 1)(3n - 5)}{4(n - 2)}$  if  $n$  is odd. So in both cases the integrality gap is lower than  $\frac{4}{3}$  and it converges to  $\frac{4}{3}$  as  $n$  grows to infinity.  $\square$

## Appendix E. Node degree information for instances from the Network Repository [33]

895

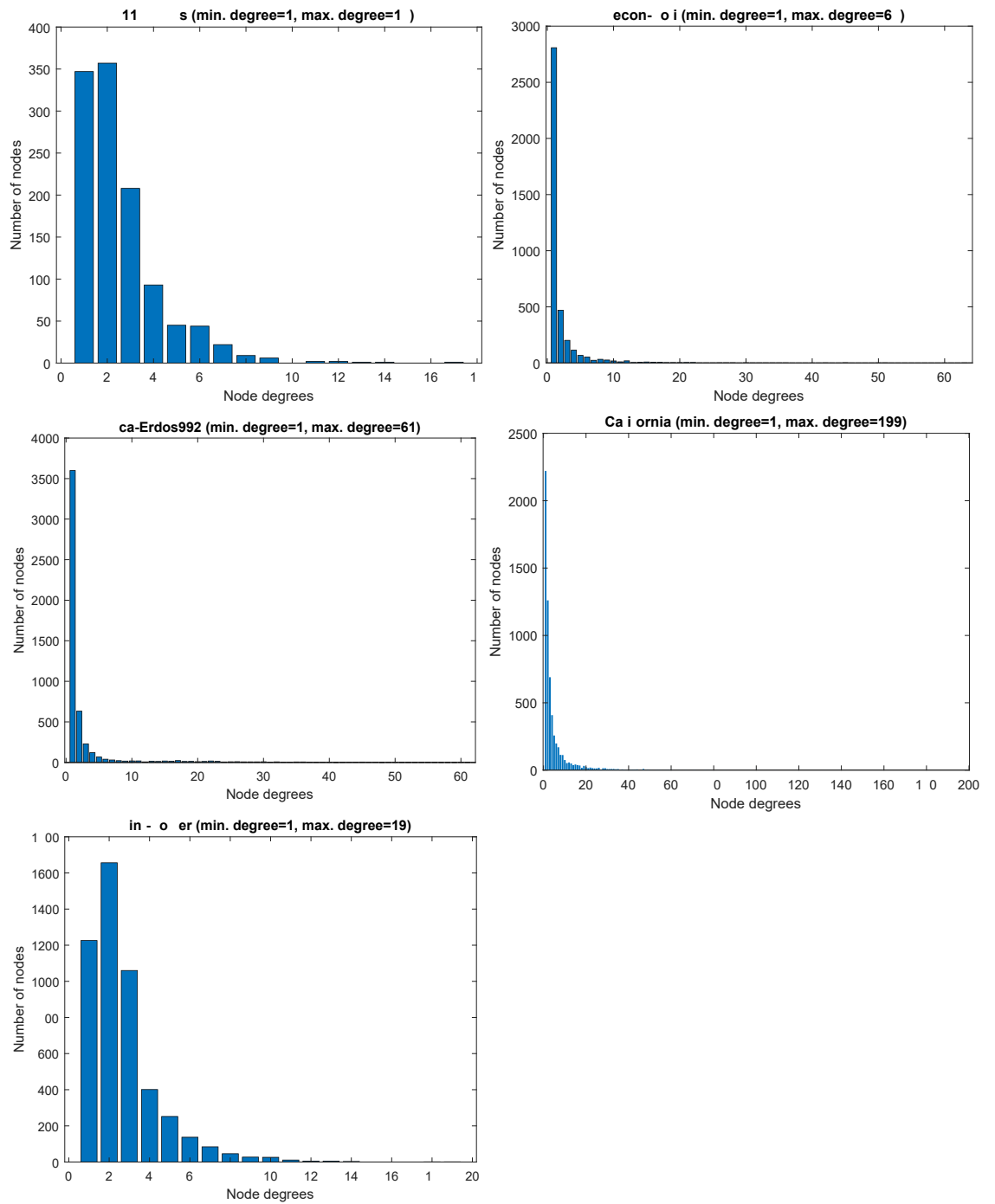

Figure E.6: Node degree information for instances stemming from the Network Repository [33]