



HAL
open science

TactJam: An End-to-End Prototyping Suite for Collaborative Design of On-Body Vibrotactile Feedback

Dennis Wittchen, Katta Spiel, Bruno Fruchard, Donald Degraen, Oliver Schneider, Georg Freitag, Paul Strohmeier

► To cite this version:

Dennis Wittchen, Katta Spiel, Bruno Fruchard, Donald Degraen, Oliver Schneider, et al.. TactJam: An End-to-End Prototyping Suite for Collaborative Design of On-Body Vibrotactile Feedback. Proceedings of the 16th International Conference on Tangible, Embedded, and Embodied Interaction (TEI 2022), Feb 2022, Daejeon, South Korea. pp.1-13, 10.1145/3490149.3501307 . hal-03564266

HAL Id: hal-03564266

<https://hal.science/hal-03564266v1>

Submitted on 10 Feb 2022

HAL is a multi-disciplinary open access archive for the deposit and dissemination of scientific research documents, whether they are published or not. The documents may come from teaching and research institutions in France or abroad, or from public or private research centers.

L'archive ouverte pluridisciplinaire **HAL**, est destinée au dépôt et à la diffusion de documents scientifiques de niveau recherche, publiés ou non, émanant des établissements d'enseignement et de recherche français ou étrangers, des laboratoires publics ou privés.

TactJam: An End-to-End Prototyping Suite for Collaborative Design of On-Body Vibrotactile Feedback

Dennis Wittchen
dennis.wittchen@htw-dresden.de
University of Applied Sciences
Dresden
Dresden, Saxony, Germany

Katta Spiel
katta.spiel@tuwien.ac.at
TU Wien
Vienna, Austria

Bruno Fruchard
bruno.fruchard@inria.fr
Univ. Lille, Inria, CNRS, Centrale Lille,
UMR 9189 CRISTAL
Lille, France

Donald Degraen
donald.degraen@dfki.de
Saarland University & German
Research Center for Artificial
Intelligence (DFKI)
Saarland Informatics Campus
Saarbrücken, Germany

Oliver Schneider
oliver.schneider@uwaterloo.ca
University of Waterloo
Waterloo, Ontario, Canada

Georg Freitag
georg.freitag@htw-dresden.de
University of Applied Sciences
Dresden
Dresden, Saxony, Germany

Paul Strohmeier
paul.strohmeier@mpi-inf.mpg.de
Sensorimotor Interaction,
Max Planck Institute for Informatics
& HCI Lab - Saarland University
Saarland Informatics Campus
Saarbrücken, Germany

ABSTRACT

We present TactJam, an end-to-end suite for creating and sharing low fidelity prototypes of on-body vibrotactile feedback. With TactJam, designers can create, record and share vibrotactile patterns online. This opens up new ways of collaboratively designing vibrotactile patterns both in collocated as well as in remote settings. We evaluate TactJam in a two-part distributed online workshop, exploring the design of on-body tactons. Participants were able to successfully use TactJam to learn about tacton design. We present an overview of mappings between tactons and their associated concepts before comparing the results of tactons created using solely a GUI and tactons created through experimenting with placements directly on the body. Conducting both parts of the workshop separately highlighted the importance of designing directly with bodies: less implicit assumptions were made, and designs were guided by personal experience. We reflect on these results and close on deliberations for the future development of TactJam.

CCS CONCEPTS

• **Human-centered computing** → **Haptic devices**; *Empirical studies in HCI*; *Interface design prototyping*; User interface toolkits.

KEYWORDS

vibrotactile feedback, tactile feedback, tactile prototyping, tactons, collaborative sketching, on-body design, embodied design, embodied interaction

ACM Reference Format:

Dennis Wittchen, Katta Spiel, Bruno Fruchard, Donald Degraen, Oliver Schneider, Georg Freitag, and Paul Strohmeier. 2022. *TactJam: An End-to-End Prototyping Suite for Collaborative Design of On-Body Vibrotactile Feedback*. In *Sixteenth International Conference on Tangible, Embedded, and Embodied Interaction (TEI '22)*, February 13–16, 2022, Daejeon, Republic of Korea. ACM, New York, NY, USA, 13 pages. <https://doi.org/10.1145/3490149.3501307>

Permission to make digital or hard copies of part or all of this work for personal or classroom use is granted without fee provided that copies are not made or distributed for profit or commercial advantage and that copies bear this notice and the full citation on the first page. Copyrights for third-party components of this work must be honored. For all other uses, contact the owner/author(s).

TEI '22, February 13–16, 2022, Daejeon, Republic of Korea

© 2022 Copyright held by the owner/author(s).

ACM ISBN 978-1-4503-9147-4/22/02.

<https://doi.org/10.1145/3490149.3501307>

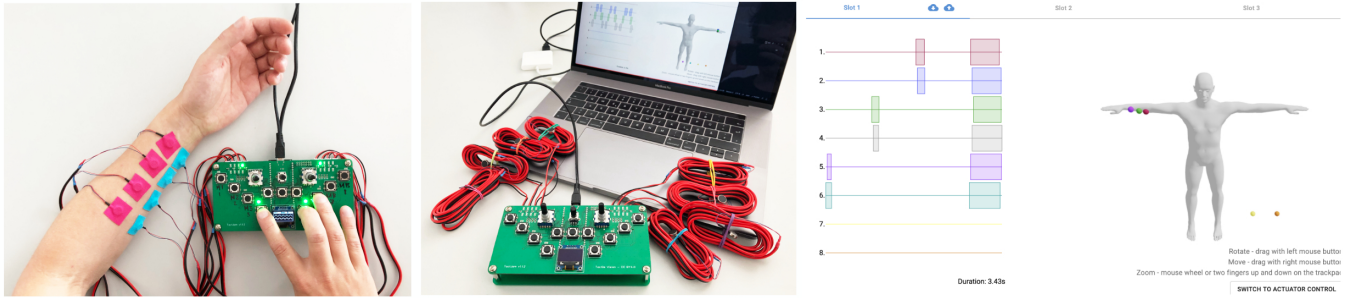

Figure 1: An overview of the *TactJam* suite.

1 INTRODUCTION

Tactile feedback and communication continues to receive less attention than vision or audio in interactive technology. Its importance, however, is known; touch is among the first senses we learn to rely on [1], and serves purposes ranging from simple reflexes to communication of complex emotions [18, 19, 53]. There have been almost 20 years of investigation into guidelines and design tools to support the creation of tactile feedback [7, 17, 40]. Yet, we still see this modality used with less prevalence.

We believe there are two reasons why tactile feedback is still something which is often added as an afterthought, rather than explicitly included in design: When people are concurrently confronted with visual or acoustic as well as tactile stimuli, they tend to prioritize the visual or acoustic element. This is reflected in visual and audio media pipelines which are well established and highly streamlined, while tactile processes are only recently being identified [33, 41, 46]. Second, design processes for all modalities rely heavily on collaboration, which remains one of the most significant challenges for both expert and novice haptic design [41, 46]. In practice and in research, it is comparatively easy to communicate visual or acoustic information through pictures and recordings; however, the same is not true for tactile feedback.

In this paper, we address the collaboration problem as a step towards improving our ability to design tactile information throughout the design process. We introduce *TactJam* (Figure 1), an open source suite of software and hardware tools for designing, storing, sharing, and testing on-body vibrotactile feedback patterns. *TactJam* supports placing up to eight actuators on a body as shown on the left in Figure 1. Designers can then *jam* by controlling each actuator in real time using button-presses on dedicated control hardware. These patterns can be recorded on the device and then uploaded to a cloud based sharing application. The device is further able to download previously shared designs, enabling the playback of tactile patterns designed by others.

This system complements industrial design tools by demonstrating how to support a collaborative haptic design process. Haptic design tools are becoming more common with Apple’s API (limited to single actuators) [24], the Lofelt [29] and Interhaptics [25] editors and middleware that enable sharing designs, or the Syntacts [38] vibrotactile rendering framework as prominent examples. With *TactJam*, we expand upon these by offering end-to-end support for collocated and remote collaborative work—from inception of

a design, to recording and sharing—throughout the haptic design pipeline.

TactJam enables prototyping, recording, and sharing tactile icons within the same environment. It supports in-situ exploration of haptic experiences and allows design outcomes to feed back into design processes. This particularly suits haptic design as we often lack a language which fully captures the richness of tactile experience [35]. It also supports the design of on-body haptics, as designers are faced with a plethora of bodily shapes and sizes, which interact with how a given tactile design is experienced. Fast sharing mechanisms enable designers to explore a range of multiple designs rapidly.

We put *TactJam* to a practical test through a two-part remote workshop on vibrotactile feedback design. Workshop results highlighted that *TactJam* supported remote collaborative haptic design. The workshops formed a type of natural experiment, which compared designing vibrotactile patterns using a GUI vs directly prototyping on bodies. This highlighted how using a GUI compared to designing directly on bodies leads to very different design results, but also very different ways of talking about and reflecting on these designs.

In summary, we make the following contributions: We present *TactJam*, an open source suite for collaboratively designing on-body vibrotactile feedback and present a qualitative evaluation comprising a two part workshop. We further share anecdotal results of tacton designs from the workshops, as well as implications of how designing on bodies or using a GUI affects design choices.

2 RELATED WORK

2.1 Vibrotactile information display

Tactile perception is largely mediated through vibration [5]. Consequently, vibrotactile actuators are a powerful tool for simulating physical touch sensations such as textures [36], forces [3], or compliance [50]. Such work, however, is predated by the use of vibrotactile feedback as information display. In 1957, Frank Geldard developed Vibratese, a vibrational representation of an alphabet across five actuators on the body [16]. In 1959, the movie *The Tingler* provided vibration feedback in theater seats [23]. This structured information display employed multiple vibrotactile actuators. The goal of such displays is to convey information as clearly as possible, rather than provide physical realism. Correspondingly the design of vibrotactile interactions usually involves a manual, iterative process, which *TactJam* was designed to support.

The design of structured vibrotactile information displays was outlined by Brewster and Brown, in their investigation of tactons, or tactile icons [7], a type of haptic icon [14]. Follow-up inquiry looked at effectiveness of information transfer [8], usability considerations such as how large a set could be learned [52], and connection to emotions [57], user experience [30], and player experience in games [47]. This work typically identifies key design parameters like frequency, amplitude, waveform, and careful timing (e.g., duration, number of pulses, rhythm).

Tactile icons have been used in scenarios like collaborative turn taking [10], and mobile/wearable situations, like a spatial vibrotactile belt to help wayfinding [39]. Other examples include emotion inducing cues using spatio-temporal vibrotactile patterns [22], and approaches combining vibrations with thermal cues [54]. The workshop used as evaluation of *TactJam* focused on the design of such tactile icons.

2.2 Haptic design tools

As haptics has become more common within HCI research, we see a pattern of design tools being developed for each new device. Early work in artistic use of vibrotactile feedback, here for tactile-music composition, recognized the need for compositional tools [17]. The Hapticon editor [14] was an early example of an editor for a 1-degree-of-freedom force feedback knob. Since then, a plethora of tools have been developed for various haptic modalities, including variable friction displays [32] and wearable pneumatic pressure displays [13].

Of these design tools, tools for the design of vibrotactile feedback are the most common, first with research prototypes and now with industry tools. The maturity of vibrotactile actuation technology makes it an easy target. In research, these show increasing complexity, from graphical editors for single actuators [40] and multiple on-body actuators [26, 37], the use of tactile illusions to abstract into a single “animation object” [42], and finally combine vibrotactile feedback with audio and video feedback in game design [51] and VR [11, 12]. In industry, companies have long used in-house tools (e.g., D-Box’s and Immersion’s editors for motion planning and vibrotactile feedback), but more recently some companies have emerged as software-focused to meet this growing need for haptic design (e.g., Lofelt, Interhaptics).

Custom DIY kits have also emerged, such as Stereo Haptics [58] for accessible 2-actuator control, and Syntacts [38] for more general wearable vibrotactile feedback. This mirrors similar DIY kits for other haptic modalities, like the Hapkit and Haply for force feedback display [15, 31]. *TactJam* is similarly designed to be easily replicable by other makers and tinkerers, its main contribution over existing kits is its intended use in remote collaboration settings.

2.3 Collaboration in haptic design

Researchers have not just built design tools, but also applied design processes to haptics [34]. For example, haptic sketching [33] has become a standard tool for people designing haptics or other physical interactive systems. Now, haptic experience design (HaXD) is an emerging design practice with similarities to other fields of design, but unique challenges [41], especially for novices [46]. One of those central challenges is collaboration.

A series of tools and techniques have helped to contribute to collaboration in haptics, but the field is still young. Mirroring two actuators’ output on a “haptic instrument” can enable two hapticians to rapidly try out and discuss ideas in a collocated setting [43]. Using open-source examples of vibrotactile effects in an online tool can help people start from scratch, and learn the idioms of haptic design [44] in an asynchronous manner. “HapTurk” showed that crowdsourced studies of vibrotactile icons are similar to those run in-person, lending them credibility, and shows that existing commodity hardware can be used as a proxy for feedback with rarer, higher-fidelity actuators [45].

However, these systems typically focus on a subset of the collaborative process or on a specific way of collaboration. *TactJam* can be used for both collocated as well as distributed collaboration, it supports both synchronous and asynchronous sharing, as well as private or shared control.

3 TACTJAM

3.1 Design Considerations

TactJam provides a tool chain for a fast and iterative design process of on-body vibrotactile patterns, and supports collocated and remote collaborative work. In this section, we outline this process, the requirements for tools needed to implement it, and the opportunities for cooperation that this opens up.

3.1.1 Design Process. While sketching, designers typically create a large number of designs with simple tools and later select a subset to refine later [9]. With *TactJam*, we focus on this first rapid, iterative sketching process, but with vibration. Much like scribbling with a pen on paper, haptic designers should be able to quickly develop vibrotactile patterns directly on their body. Iterative sketching helps identifying strong ideas through multiple processes. For one, capturing an idea concretely helps designers to think about their sketch and identify strengths and weaknesses. Beyond that, an important part of this iterative sketching process is the ability to share and discuss sketches with others for soliciting feedback and outside opinions. *TactJam* is also explicitly designed to support these processes by providing the ability to record, display, and share vibrotactile patterns.

In summary, with *TactJam* we intend to support these three main activities:

- (1) Sketching, which is done by attaching actuators on the body and jamming with them, by playing vibrotactile patterns live for experimenting with experiences.
- (2) Recording vibrotactile patterns, and providing vibrotactile playback to support reflecting on a captured idea.
- (3) Documenting the vibrotactile patterns and sharing with others, for collecting feedback and for remote collaboration.

Throughout all steps, designers should be able to experience the tactile feedback they produced.

3.1.2 Tools. To support the proposed activities we use two separate tools. The *TactJam hardware* allows for sketching and reflecting. The *TactJam GUI* supports documenting and collaborating remotely. Both parts of *TactJam* communicate with each other, while being fully functional as standalone systems. The *TactJam*

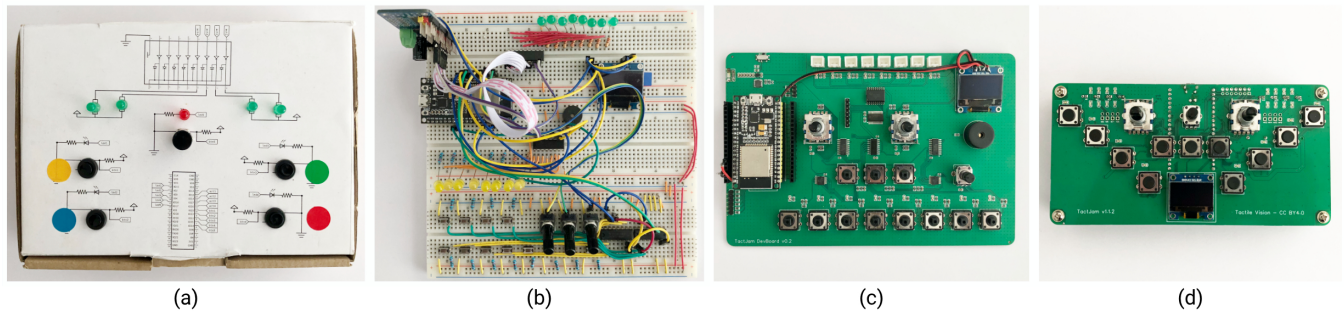

Figure 2: (a) Initial prototype of *TactJam* used for teaching, (b) breadboarded version of *TactJam* designed for TEI workshop, (c) first PCB version of workshop device and (d) re-designed workshop device with improved ergonomics for bimanual hand-held use.

hardware is portable so users can design vibrotactile patterns without requiring access to a PC. The device can be held and used like a game-controller in mobile situations. The device also comfortably sits on a desk and can be used like a keyboard. Eight actuators can be individually connected to the *TactJam hardware* and have long cables to attach them anywhere on the body.

The *TactJam hardware* has three modes which mirror the main activities outlined above:

- (1) Jamming, where each actuator has a corresponding button that turns the vibration on or off. The global amplitude of vibration can be modulated with a rotary controller.
- (2) Record/Play, where users can record button presses and amplitude modulations. These can then be played back.
- (3) Data Transfer, where the physical device connects to the GUI. From it, recorded vibration designs can be uploaded to or downloaded from a server to the device.

To compare and contrast designs, *TactJam* has three independent ‘slots’ to work with. This allows, for example to record patterns in slot one and slot two and switching back and forth between them. Concurrently one might use slot three for testing new ideas, or download a third pattern created by someone else using the *TactJam GUI*.

The *TactJam GUI* handles the persistent storage in a remote database as well as viewing, sorting, and retrieving vibrotactile patterns from this database.

3.1.3 Collocated and Remote Collaboration. Schneider and MacLean described several design dimensions for *haptic instruments* [43]. Some of these consider the collaborative aspects of such tools, e.g. collocated/distributed output, synchronous/asynchronous output, and private/shared control [43]. *TactJam* is designed to provide designers with flexibility, by supporting all the described aspects (but to varying extent). Similarly, *TactJam* is designed to be used on oneself or on another person, which provides further flexibility.

When two or more designers are **collocated**, *TactJam* can be set up so that the actuators of designer one are placed on the body of the designer two. Here designer two perceives the tactile sketches of the collaborator *synchronously*, but designer one needs to rely on verbal feedback from designer two. Both designers can place the actuators on their own bodies, which allows them to experience

their respective sketches in real time, but requires *asynchronous* sharing of sketches. In addition to *private control* (one device per user), multiple designers can use a device together for *shared control* over the actuation. Similarly, one device can be used to attach actuators on and provide output to multiple people. These uses, however, are constrained by the number of available actuators and the ability of multiple people to reach the device concurrently.

The focus of the design of *TactJam*, though, is to support **distributed** usage. That is, design in a context where multiple designers are working from different locations. This focus emerged as *TactJam* was originally designed to facilitate shared sketching of vibrotactile patterns during the COVID-19 pandemic. In this case, *TactJam* provides *asynchronous* output via playback of recorded patterns where each user has *private control* over their own device. Equipped with *TactJam*, users can share their designs, discuss ideas and can further elaborate them iteratively.

3.2 Implementation

TactJam is a fully open source hardware (Figure 2) and software (Figure 4) for designing on-body vibrotactile patterns. Hardware and software can be used together or as standalone systems. All source materials are available online: <https://github.com/TactileVision>.

3.2.1 Hardware: The *TactJam* hardware consists of a 160×80 mm PCB with SMD and through-hole components. As it is intended to be used without casing, all buttons, switches, encoders, LEDs and the display are mounted on the top side of the PCB while all non-interactive components are on the side facing downwards. These downward-facing components are protected by an acrylic plate, attached with 20 mm spacers.

The main PCB acts as an extension board to the ESP32 NodeMCU with ESP32-WROOM-32 chip from AZ-Delivery. The ESP32 connects to the main PCB through standard headers mounted on the downward facing part of the PCB. The top side consists of eight tactile switches (M1 – M8, Figure 3) to trigger up to eight actuators simultaneously and a potentiometer for setting the global amplitude. Rotary switches are used to toggle between the device’s modes (*jam*, *record/play*, and *data transfer*) and for choosing one of three slots to work with vibrotactile patterns. Finally the board has three general purpose buttons to trigger context relevant functions, e.g.

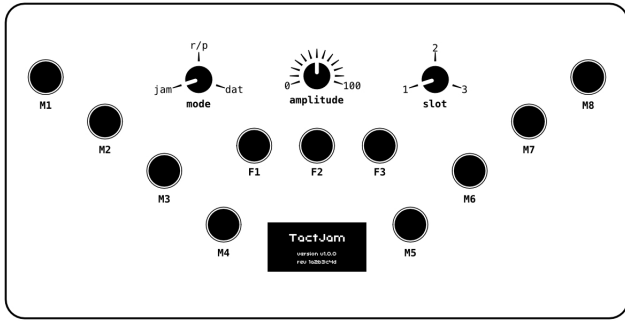

Figure 3: Hardware user interface, with eight actuator buttons (M1–M8), three function buttons (F1–F3), knobs to select the mode, slot, and amplitude, and the display.

to start/stop record and play (F1 – F3, Figure 3). Feedback regarding the device’s state and settings is provided with a monochrome OLED display (128×64 px) and errors are indicated with a buzzer.

The device supports up to sixteen Eccentric Rotating Mass vibration motors (ERMs) as actuators, connected to the PCB via JST connectors and a 1.5 m long cable. We use the NFP-C1030L brushed coin vibro motors (∅ 10 mm and 3 mm thick) for actuation and are powered with a separate 5 VDC power supply via an additional micro-USB port.

3.2.2 Firmware & Data Format: The firmware is implemented using PlatformIO [27], the *Espressif 32* platform [28] and the *Arduino* framework [2]. The firmware has three major tasks: (1) handle inputs (e.g. button presses), (2) record and play vibrotactile patterns, and (3) communicate with the PC to transfer data between both entities.

The device can record and store up to three tactile patterns in the on-board flash memory of the ESP32. Patterns are stored as a series of 32bit binary instructions. The encoding and decoding system is implemented using *libvtp* [20] for memory efficient binary encoding and decoding. Each instruction consists of an instruction type (*increment time*, *set amplitude*, or *set frequency*), actuator ID, time offset to last instruction and finally the value to set. For example, a command to change the amplitude is structure as follows:

- 4 bit instruction code (0010)
- 8 bit actuator id (all actuators if zero)
- 10 bit time offset in milliseconds to last instruction
- 10 bit amplitude

If the time offset exceeds the 10-bit limit of 1023 ms the *increment time* instruction can be used with the following structure:

- 4 bit instruction code (0000)
- 28 bit time offset in milliseconds to last instruction

As frequency and amplitude are coupled for ERMs (the parameters influence each other, and can therefore not be tuned separately from each other), the current iteration of *TactJam* does not use the set frequency command, however it is implemented for compatibility with other vibrotactile pattern generation tools such as that provided by *bARefoot* [50].

3.2.3 GUI and Backend: An important piece of information which *TactJam* cannot automatically record is the location of a given actuator. However, knowing where an actuator is placed is absolutely crucial for recreating an on-body vibrotactile pattern. Therefore, the automatically encoded pattern needs to be complemented with clear documentation of where actuators are placed. The purpose of the GUI is then to provide this documentation before uploading the pattern to a server. Additionally, the GUI provides a visualization of the vibrotactile design.

The *TactJam GUI* automatically connects to the firmware as soon as the device is plugged in to the computer via USB. To enable sharing vibrotactile patterns remotely with others, we use a backend centralized server to which the GUI also connects automatically. All vibrotactile patterns are saved on the server and can be accessed by all users at any time.

Once a vibrotactile pattern is loaded on the GUI, the *time profile* of each actuator is depicted as a continuous line with an area of varying thickness corresponding to the vibrations amplitude (Figure 4, left). To document what actuators are being used and where they are located on a body, the GUI provides a 3D mannequin (Figure 4, right), the location of actuators on a body must be manually indicated by moving colored dots on to the corresponding locations on the mannequin.

Before uploading patterns to the server, users are prompted to provide a *title* and *description* of the pattern, as well as *tags* indicating the body parts engaged in the design and custom tags defined by users. To download a pattern users browse a page that lists all existing patterns including meta information, and select one of them. To simplify searching for vibrotactile patterns, a search text field filters the list dynamically.

4 TACTJAM WORKSHOPS

TactJam was put to a practical test during a two session online workshop at TEI 2021 [55]. Overall, 17 participants from North American and Europe (six countries total) designed ten tactons in the first session, and implemented 32 tactons in the second. Participants were almost equally split between students and faculty, with eight

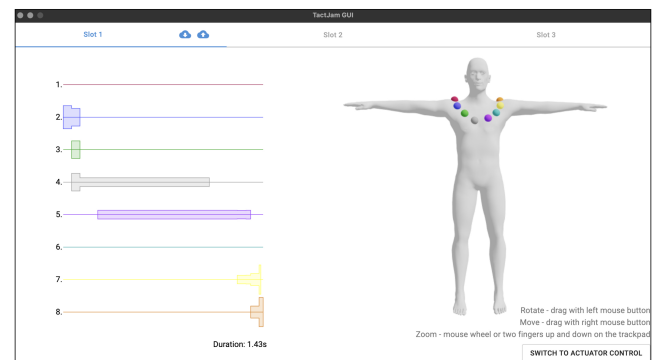

Figure 4: Screenshot showing the graphical user interface. A visualization of the pattern recorded by the *TactJam* hardware can be seen on the left. The positions of the actuators are manually indicated on the right, using this GUI.

participants having finished their PhD and nine still studying (one in a BA degree, two in a Master's degree and six working towards a PhD). About 2/3 of participants presented as more masculine and at least one participant was non-binary. The participants' research interests spanned from haptic material and experience design, safety critical systems, animal-computer interaction to interaction design more generally.

The workshop was held in two distinct sessions, two months apart: the first focused on theory and designing tactons without experiencing them, and the second focused on implementing the former ideas and reflecting on theoretical design choices with the device available to participants. Both sessions were approximately four hours long.

In the first session, participants were asked to design tactons using three prompts: *topics*, *contexts*, and *design goals*. For all prompts participants were provided with examples and participants were encouraged to add their own ideas. We proposed topics such as *tactile emotions*, *social presence*, or *time mapping*, contexts such as *biking*, *gaming* or *physical activities*, and design goals such as *enhancing immersive experiences* or *designing unambiguous feedback*. We accompanied each *topic* and *context* with a list of examples presented as textual label and an icon. Participants worked in groups to design vibrotactile patterns and discuss their ideas. They used the *TactJam GUI* to illustrate the actuator placements and added descriptions to specify the spatio-temporal properties of each vibrotactile pattern.

The main activity of the second session was *physical* on-body design with a functional prototype. As we observed differences in the designs resulting from these activities we deem relevant and interesting, we initially report a summary of results for each session individually.

Our analysis is grounded in *textual* data such as documents created by individual groups and personal notes, chats, and video recordings of final group discussions through their transcripts as well as *visual* data in the form of digital representations of the resulting tacton designs. We analyzed textual data using a light-weight coding and theming approach [6] involving four steps: 1) familiarizing ourselves with the data (*sensing*), 2) creating a coding frame to ensure *reliability*, 3) identifying relevant *codes* regarding e.g., intent, inspiration, metaphors used, or envisioned experiences, and 4) *interpreting* those in context. These steps are of iterative character and can be repeated and returned to as needed [ibid]. For visual data, we conducted a schematic analysis [49] to identify common and differing characteristics between the different designs and interpreted them together with textual data. This analysis was led by the second and last author and discussed with all authors to ensure a coherent narrative.

4.1 Workshop 1: GUI-based Design

The first workshop was conducted without the *TactJam hardware*. Tactile icons were designed using only the *TactJam GUI*. To provide some constraints to this exploration, participants and organizers formed small groups to explore tactile icons for specific settings. In the end, four distinct groups formed who chose the contexts of bicycling (G1), Virtual Reality (G2), Sports (G3) and Hospital Intensive Care Units (ICU) (G4), respectively (see also, Table 1). Each

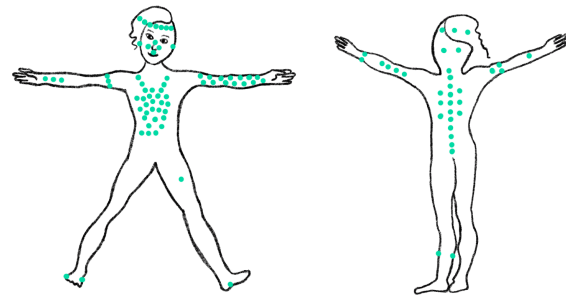

Figure 5: Locations selected during workshop one

group consisted of three to four participants and would independently conduct their design deliberations. These were presented in a group discussion at the end of the workshop which was recorded and builds the core data basis for the second part of our analysis regarding designers' reflections.

4.1.1 Actuator Locations. Participants designed tactons which used actuators all over their bodies. Emphasis was along the arms, on the chest, down the spine and around the head. An overview of selected locations is presented in Figure 5.

4.1.2 Design Reflections of Participants. The group discussion at the end of the workshop was structured around each group presenting their individual tacton design(s) and reflecting on their intent, inspirations, and experiences for half an hour. During the presentations, group members commented and added on what was said whereas all workshop participants were invited to ask questions or comment on the designs and deliberations. We report here from the thematic analysis (along Boyatzis's style [6]) of the video recording and transcript thereof across presentations. Instead of zoning in on the individual designs, we focus here on how participants communicated their designs and which points were prominent in presenting them.

Primarily, participants were interested in **communicating their intent** around the designs. Here, we observed a tendency to focus on logically driven, clear mappings between information and sensory experiences with an emphasis on the information conveyed. P3, for example, indicates how information flows in their concept oriented on guiding bicyclers through traffic.

Another idea was to indicate, on the cyclist's back, which direction to turn next or whether to stop at all. – P3

In cases where sensory experiences were mentioned, they largely were relegated to notions of equivalence, i.e., aiming at allowing immersive experiences that would not be accessible without using a set of vibrating motors. Here, participants aimed at providing people who lost a limb an option to counteract phantom pain or offering up sensory experiences of different embodiments, most prominently that of an elephant, as P7 describes.

It's this idea of, if you touch something, can you give the feeling how an elephant would interact with things? – P7

Identifier	Group Context	Examples
G1	Bicycling	Alerting for oncoming traffic Indicating information regarding the weather forecast
G2	Virtual Reality	Supporting immersion when playing as non-human characters (e.g., elephants) Facilitating management of phantom pain in the case of limb loss
G3	Sports	Providing suggestions for workout intensity Structuring timings in high intensity interval training
G4	Intensive Care Units (ICU)	Guiding hospital staff to where care is most urgently needed Communicating to and calming patients when staff is on their way

Table 1: Contexts of investigation during both workshops

The way participants talked about the groups they designed for, they often used phrasings that indicated they preferred to **design for other**, meaning they chose scenarios that feasibly had someone else interacting with the resulting artefact. P2 notes this explicitly:

... we want to support caretakers in knowing where to be at what time and what priority it is. – P2

Hence, intended target groups were imagined external to the set of workshop participants. As participants' familiarity with the target contexts varied, they made assumptions about others' experiences. This reasoning might lead to complicated implications for the appropriateness and suitability of those designs (cf. [4]), for instance in the context of disabilities that participants had no personal experiences with themselves. The underlying assumption is the equivalence of experiences made in a specific bodily area and produced with sensory input at another.

We replaced the sensors on the foot they have lost and moved it to another place of the body. – P4

However, some participants also discussed the impossibility of actually understanding how sensory experiences are made in other contexts, e.g., for animals. P6 muses about this extensively in the context of the above mentioned elephant.

... if you have a trunk, then it's an arm with fingers at the end and it's also a nose, and it's also a tongue, and it's actually also a noisemaker, and it's something that you put food in your mouth with. It has so many uses. How is it possible for us to imagine that? – P6

Finally, participants aimed at **imagining experiences**, largely due to the abstract nature of the designs grounded in a lack of knowledge of the corresponding experiences. Here, they often drew on known interactive experiences and specific ones they made personally from which they envisioned how the populations they designed for would experience and feel about interacting with the potential artefacts.

That's like moving from slow to intense or something coming towards you. – P5

Participants also noted how these populations would make meaning about the interactive experiences. Particularly the following statement by P2 indicates how experiences for others were imagined with a caring intent behind.

You want people to know what's coming, maybe do it in a reassuring way like a stroke on the arm, and try and get that aspect of sense of touch. – P2

Given the setup of the first workshop, participants provided largely structured and logically driven designs. They oriented themselves towards an expanded set of embodiments not just representing the ones already present among participants; however, that also means they prioritized their own assumptions about these experiences, as well informed as they might have been, over those of people who make them first hand. Ultimately, experiences had to be imagined and could not be verified, leading to reflections more oriented on intent than actuality of designs.

4.1.3 Workshop Results: Tacton Mappings. Something we were especially interested in were metaphors and mappings participants might chose when creating tactons. We therefore summarized these mappings using affinity diagrams and identified four major categories:

Nominal mappings where participants mapped a discrete design to a specific purpose. Such mappings might be *naturalistic*, where a tacton simulates the concept it represents. An example of a naturalistic mapping was a zig-zag pattern on the back of a cyclist, which communicated upcoming thunderstorms (Figure 6a). Another type of mapping might be *logical* where the tacton reflects the logical organization of a concept. An example of this were two actuators placed on top of each other. If the higher one vibrated, this communicated to a cyclist that they should switch into a higher gear, if the other, lower, one vibrated, the cyclist should switch into a lower gear (Figure 6b). Participants also used *visual analogies*, for example, by arranging a set of tactons to represent, for example, the familiar visual icons for the play or pause symbol.

Another type of mappings were **Body Based** mappings. These again included *spatial* mappings, where a tacton might communicate a location on a body, or directions relative to a body (Figure 6c), for example, highlighting contextual cues such as surrounding traffic or directly guiding cyclers towards specific directions. Another type of body-based mapping was *perceptual*. Here tactons were used to communicate perceptual events. For example by providing feedback on the shoulder when a prosthetic hand would touch an object, or providing a human with feedback on the nose, so they might experience what it feels like to be an elephant (Figure 6d).

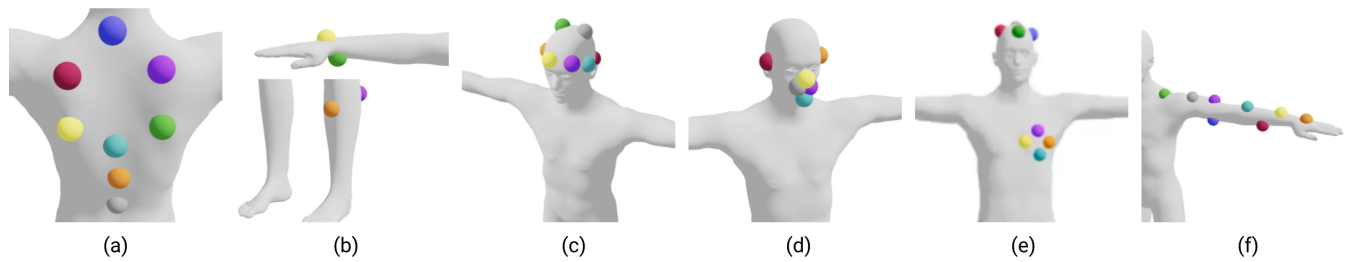

Figure 6: Tactons shared in the wrap-up session of workshop one. a) Naturalistic mapping: tactons display the weather on the back. Rain is presented by intermittent random vibrations, while lightning is shown as zig-zag pattern. **b) Logical mapping:** Top of wrist for switching to higher gear, bottom of wrist for switching to lower gear. Front of shin for faster, back of shin for slower. **c) Temporal mapping:** Heart rate and body temperature are communicated based on the speed of circular vibration patterns. **d) Spatial mapping:** Directions in VR are interpolated using the actuators distributed on the head. **e) Perceptual mapping:** Actuators are placed at locations, where an elephant would have sensory experiences a human usually would not have access to. **f) Affective mapping:** Actuators are placed so they might be used to provide a calming gesture.

A further type of mapping we encountered was **Magnitude**, where variations in the tacton design provided a quantitative element to the concept they communicated. Examples included, again, *spatial* mappings, for example, actuators might be arranged in a row, and depending which actuator vibrates, this might indicate how urgent something is. Similar strategies were represented in a *temporal* manner. The speed with which a pattern repeated might provide feedback to a runner on their pulse or body temperature (Figure 6e). Finally the magnitude of a concept might also be communicated by the *magnitude* of vibration. For example, the number of actuators vibrating might indicate how soon an event will occur.

The final type of mapping we found was **Affective**. Here, tactons were designed to communicate a concept to support creating a target mood in the person with the tacton. For example, in a hospital setting, a patient might receive a tactile notification telling them that a nurse is on their way. The tacton might then be designed to simulate a gentle touch, with the intention of soothing and reassuring the patient (Figure 6f).

4.2 Workshop 2: On-Body Design

In the second workshop, the same groups came together to implement the designs from the previous workshop using the *TactJam* hardware (see Appendix for additional visualizations of vibrotactile patterns). As most participants invested most of their time in unstructured experimentation with the hardware, the final round was held as an open discussion.

4.2.1 Actuator Locations. The locations chosen for the on-body prototyping were noticeably less diverse than during the first session. Most tactons were placed on the left arm, while some were placed around the chest (Figure 7). To our surprise, the face and neck were also used extensively. Actuators were additionally placed on dog noses. We speculate that two different factors might have influenced this. For one, the social awkwardness of some locations was experienced much stronger in the actual on-body context. Further, as most participants were alone during the workshop, locations were constrained to those they could reach themselves as well as to body parts participants were willing to expose in an online setting.

4.2.2 Design Reflections of Participants. The concluding discussion and reflections on the second workshop were analyzed in the same fashion as the first workshop. However, the conversation was less structured along groups and participants overall spoke more freely – largely about the experiences they made and to a lesser extent attached to design intents.

During the second workshop, participants focused their reflection on their activities experimenting with their own bodies and exploring **sensory experiences** they made themselves. In describing these explorations, they used less concrete words and relied on a shared sense of how things should feel.

*I think I started with pulses and then I went with swoops.
So I was really trying to play around with the volume.
And I found that like having that ease in, that ease out,
that fade in, fade out. – P2*

Figure 8 and the supplementary figures in the appendix illustrate this iterative approach. There was a fairly hedonic drive in experimenting with the sensory potentials with participants seeking out pleasurable experiences. Subsequently, they reported feeling ‘good’ about their explorations and modulating them in ways they personally found rewarding.

I really like the feeling to use vibrations in different positions. – P14



Figure 7: Locations selected during workshop two

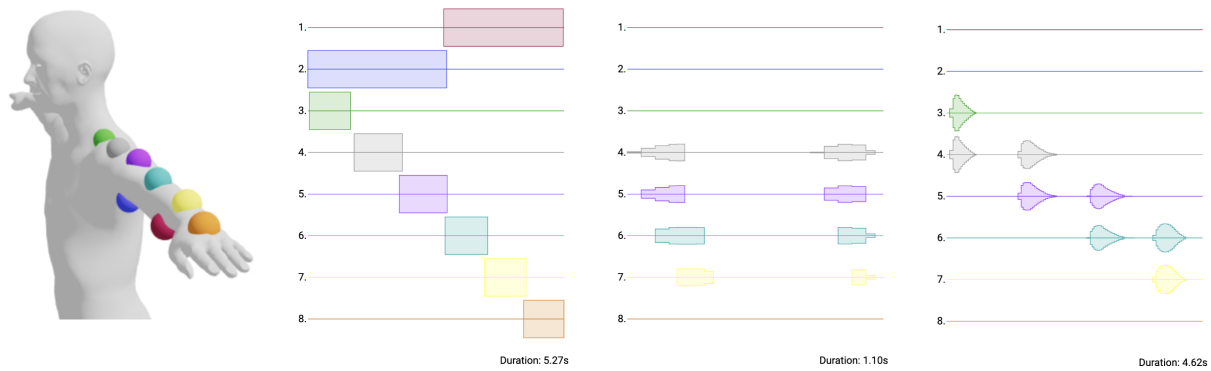

Figure 8: Example of tacton design from workshop two. Note the iterative nature of the temporal patterns and the increasing use of amplitude dynamics (swoops).

Having that extra amplitude is the only way we can get continuous stuff, which is more biological and more, I don't know, just pleasant, right? – P2

Participants also experimented with objects (and non-human animals) that surrounded them and reflected on how vibrotactile experiences differed along different body parts and configurations.

I put some on a headset because I happened to have one of those, stuck some on here. And that was a real buzz, because it's right next to your skull and everything. That was a huge shock. I also tried it on my dog's nose and I got a quite strong reaction from her when I did that. – P6

The surprise P6 states here on how **their imagination differed from their experiences** was shared among participants in a range of ways. For example, P9 describes how they experimented with actuator placements in ways they previously found conceptually ill fitting or imagined as unpleasant.

I was trying a bit on the throat which is super interesting and very not aggressive at all. Whereas I would have thought, without trying it, that it would be like, "No, don't put something on my throat." – P9

Participants further reflected on their previous designs and how assumptions about the experiences shaped them. In some cases, however, as P10 describes, exploring different designs through on-body placements proved crucial to **assess the feasibility** of prior ideas – sometimes indicating that they could not be implemented in the way previously intended.

I thought it would be well more distinctive with regard to the play shape. When I tried it out on my arm, it was hard to recognize a certain pattern or recognize which shape underlies the different vibrations. – P10

In another case, participants indicated that a previously assumed equivalence between experiences made with vibrotactile patterns placed on arms and those placed on a chest did not hold. They started reconsidering their assumption and reflect on how they could consider the differences going further.

It failed gloriously because it was an entirely different experience and that we treated it then as well as a different experience. – P11

While participants were more focused on exploring sensory experiences for themselves on their own bodies, they also shared tactons with each other. In these cases, designs that were initially intended for personal use or stemmed from individual explorations, were then made available to other participants and became designs not just for self, but also for others. Two participants mentioned the resulting **intimacy** they experienced explicitly, with P12 pondering on the interpersonal meanings created by this practice.

The very first time, I downloaded [another person's] tacton, I had this moment where I wondered what the social meaning or what that means to download somebody else's tacton. And I guess we were also, especially, we were designing things that feel pleasant. – P12

As participants noticed this **mismatch between earlier assumptions and the experiences they made** themselves, some tried to find an explanation as to why this was the case. P13 hinted at a lack of training regarding vibrotactile sensitivities of participants.

I wanted to share that it's really hard to imagine how stuff feels. [...] I think humans are just really not used to imagine how tactile input feels and tactile output on the skin. – P13

Participants also provided the development team with a range of suggestions for further improvements on the interaction of *TactJam* hardware and software parts for design iterations. Overall, though, participants largely explored sensory experiences for themselves during the second workshop, re-evaluated their prior designs and sought out explanations for the meaning behind sharing on-body experiences as well as the divergence between assumptions driving designs in the first workshops and experiences made in the second.

4.2.3 Workshop Results: Tacton Mappings. The re-evaluations made when working on the body, lead to new insights about tacton mappings.

Participants identified a new type of mapping, **action centric mappings**. These are tactons, which are modified based on what the user is doing. For example, their intensity might increase while the user is reaching for an object.

Participants also found that **affective** mappings were almost unavoidable, and more complex than assumed. This manifested in the simple desire of participants wishing to continuously test some patterns, simply because they felt nice, even though they were not designed with that in mind. Other examples included tactons created with spatial metaphors in mind, which were experienced as arousing or as calming. However, factors such as variability of body shape, e.g.: size and distribution of muscles and fatty tissue, impact how vibration propagates, making it difficult to transfer these experiences between participants.

Participants found that borrowing *visual analogies* did not work well. For example, actuators organized in the shape of a play or pause symbol lost their meaning, when the body (and consequently the icon) changed orientation. We share visual impressions from workshop two in Figure 9.

5 DISCUSSION

TactJam enabled 17 people from six countries, two continents and three timezones to come together and collaboratively prototype on-body tactile experiences. There was something profoundly satisfying, to be able to speak with a person sitting thousands of kilometers away and then, with a couple of mouse-clicks and button presses, be able to share a bodily experience with that person. *TactJam* also supported serendipitous discovery, both accidental, for example by erroneously uploading tactons designed for the arm to an actuator pattern placed on the chest as well as through playful experimentation, for example by designing tactons on the lips, or together with their pet.

We argue this sense of discovery and playfulness was in part enabled by the features of *TactJam* for sharing of vibrotactile patterns. Participants did not need to worry about uploading specific files online for their collaborators to download, but could instead focus on testing and discussing their designs. *TactJam* further helped participants document their work by integrating means to report on the logic of each design.

Consequently, *TactJam* not only enabled playful collaboration, but through this collaboration allowed participants to learn about vibrotactile feedback design and deepen their knowledge of tacton design. It should be highlighted that experts who had been working with vibrotactile feedback for years were able to deepen their knowledge through playing with *TactJam* while complete novices were similarly able to not only produce tactons, but through these tactons produce insights which we share in the results sections of this paper.

5.1 Comparisons between Workshops

A further exciting aspect about the workshops is that, together, they created something akin to a natural experiment comparing design by means of a GUI tool to designing directly on bodies. We observed how the tools used lead to relevant differences in how participants reflect on their designs and associated experiences. On a language level, when using the GUI, participants used many comparisons and metaphors to describe their intent and the inspirations they drew from. Hence, metaphors indicate a design potential. In contrast, when working directly on bodies, participants relied on analogies when describing their experiences and used more abstract notions

to convey how things felt to them. Hence, as the envisioned interactions become concrete and translated into sensory experiences, metaphors and clear design constraints become less relevant to create new designs and communicate them to others. Additionally, the designs created become more personal, not just in how they are experienced but also in how they have meaning for those engaging with them.

Across both workshops, we re-affirmed that designing for bodies requires designing with bodies (as suggested by [21]). However, in both workshops participants prioritized their individual perspectives on bodily experiences. Working with the GUI these were used for making assumptions about how something might feel, whereas when working with their bodies, participants extrapolated from their own experiences onto others'. This was partly due to the specific setup of the workshops, though we need to stress here that to account for the diversity of bodies, designers will need to actively seek out the perspectives of those they design for and consider designing *with* their target populations especially if they hold different embodied experiences from their own (see [4]).

Even though participants mentioned the intimacy involved in sharing sensory experiences amongst each other, this experience was limited, presumably due to the professional setting. Here, our workshops provide only a glimpse into the potential we see for *TactJam* to facilitate interactions between humans and allow for shared meaning making.

Ultimately, the workshops highlighted that the tools we use shape the way we think about embodied interactions with vibrotactile patterns. The choice of tools therefore can lead not only to different ideas and design proposals, they also convey different experiences and allow for more distance or closeness of designers to their designs.

Using the GUI, participants largely designed for populations that they were not necessarily part of, while when working on their own bodies, designs were largely driven by personal preferences and assessed in light of personal experiences. However, given how the placement of tactons in the second workshop was much more limited, socio-technical factors – such as presenting and discussing bodily experiences to a group of relative strangers and having cameras focused on faces while individually sitting in single rooms – play additional roles in how people design around and with their bodies. The workshops provide initial comparative insights regarding the qualitative differences of designs and reflections based in an embodied design process as compared to design with a more traditional GUI.

5.2 Limitations and Future Work

This is not to say that everything worked perfectly during the workshops. As with any first deployment of a system, we encountered bugs, as well as areas where we wish we would have done things differently or done more. Here we wish to again stress that *TactJam* is open source, and that anyone is invited to reproduce the devices, use the software and iterate on it, maybe even addressing some of our own critique (see also <https://github.com/TactileVision>).

While *TactJam* was explicitly designed to support rapid creation of a breadth of lo-fi prototypes, rather than as a tool for editing and refining designs towards higher fidelity, this was perceived as



Figure 9: Participants while trying several actuators placements during workshop two.

a major missing feature of the *TactJam* suite. The ability to edit time profiles of actuators using the GUI (as is done with the haptics composer by Interhaptics, [25] or in work by Schneider et al [44]) and copying, pasting, and swapping profiles between actuators was the feature most commonly requested.

The virtual mannequin standing in a T-pose which is currently used by *TactJam* for documenting the placement of actuators on the body also proved a non-ideal choice given its lack of flexibility (see also, Figure 4). For one, many workshop participants did not identify with it and would have preferred the ability to customize it, to better match their own bodies, or the bodies of the target group they were designing for. This also had practical design consequences, as it masked difficulties which arise when designing a fixed layout for multiple bodies (see also [48]). One might also speculate if the chest had been used as frequently for placing tactons in workshop one, if the mannequin had larger breasts. Finally, the fixed mannequin posed problems for participants who intended to design tactons for people with missing limbs, or for non-human bodies (such as elephants and dogs...).

In terms of the implementation, a concrete lesson learned from the hardware design was to stay away from SMD micro-USB connectors. These were the most frequent point of failure of the hardware, both during assembly, as well as during use. Another hardware design question which caused much discussion was whether ERM motors were the right tool to use, when better actuators are available. ERM motors were chosen in the spirit of low-fi prototyping which *TactJam* is designed for. Recoil-Style Tactile Actuators [56] or Linear Resonate Actuators (LRA) would have opened up a whole new dimension of experimenting with vibration frequency. While we would like to see a version of *TactJam* using high-fidelity actuators in the future, we speculate that this might have hampered the rapid iteration process we aimed for.

6 CONCLUSION

In this paper, we presented *TactJam*, an end-to-end suite for creating and sharing low fidelity prototypes of on-body vibrotactile feedback. With *TactJam*, designers can create, record and share vibrotactile patterns. The ease of sharing between local and remote collaborators using *TactJam* opens up new ways of collaboratively designing vibrotactile patterns.

We showed the utility of *TactJam* by putting it to practice in a two day distributed online workshop, exploring the design of on-body tactons. Participants were able to successfully use *TactJam* to learn about tacton design. Participants used a wide range of mappings between tactons and the concepts they represent, which we shared in this paper.

Additionally, comparing workshop discussion and results when a GUI was used for creating tactons to when participants worked directly on their bodies highlighted that the tools used heavily influence the outcome. Tactons created using the GUI were more structured, used a larger area of their bodies and had clearer mappings. While tactons created through sketching directly on bodies came with less implicit assumptions about other bodies and focused more strongly on the experiential dimension of vibrotactile feedback.

Finally, we wish to again highlight that all source materials of the work presented here are available online and we invite researchers and professionals interested in designing tactile feedback to explore and extend *TactJam*.

ACKNOWLEDGMENTS

We would like to thank all participants of the two workshops, without them this paper would not exist. We also thank Alexander Mamedow, Richard Adler, Martin Johnne, Christopher Praas, Lucas Hindenberger and Jonas Brusckke for their support while building *TactJam*. This project received funding from the European Research Council (ERC StG Interactive Skin 714797) and the Hertha-Firnberg Grant T 1146-G by the Austrian Science Fund (FWF).

REFERENCES

- [1] Margaret Addabbo, Elena Longhi, Nadia Bolognini, Irene Senna, Paolo Tagliabue, Viola Macchi Cassia, and Chiara Turati. 2015. Seeing Touches Early in Life. *PLOS ONE* 10, 9 (sep 2015), e0134549. <https://doi.org/10.1371/JOURNAL.PONE.0134549>
- [2] Arduino AG. 2020. Arduino. <http://arduino.cc/en/Reference/HomePage> Last accessed 06 July 2021.
- [3] Tomohiro Amemiya and Taro Maeda. 2008. Asymmetric Oscillation Distorts the Perceived Heaviness of Handheld Objects. *IEEE Transactions on Haptics* 1, 1 (2008), 9–18. <https://doi.org/10.1109/TOH.2008.5>
- [4] Cynthia L. Bennett and Daniela K. Rosner. 2019. *The Promise of Empathy: Design, Disability, and Knowing the "Other"*. Association for Computing Machinery, New York, NY, USA, 1–13. <https://doi.org/10.1145/3290605.3300528>
- [5] Sliman Bensmaïa and Mark Hollins. 2005. Pacinian representations of fine surface texture. *Perception & Psychophysics* 67, 5 (01 Jul 2005), 842–854. <https://doi.org/10.3758/BF03193537>

- [6] Richard E Boyatzis. 1998. *Transforming qualitative information: Thematic analysis and code development*. sage.
- [7] Stephen A Brewster and Lorna M Brown. 2004. Tactons: structured tactile messages for non-visual information display. (2004).
- [8] L.M. Brown, S.A. Brewster, and H.C. Purchase. 2005. A First Investigation into the Effectiveness of Tactons. In *First Joint Eurohaptics Conference and Symposium on Haptic Interfaces for Virtual Environment and Teleoperator Systems*. IEEE, 167–176. <https://doi.org/10.1109/WHC.2005.6>
- [9] Bill Buxton. 2010. *Sketching user experiences: getting the design right and the right design*. Morgan kaufmann.
- [10] Andrew Chan, Karon MacLean, and Joanna McGrenere. 2008. Designing haptic icons to support collaborative turn-taking. *International Journal of Human-Computer Studies* 66, 5 (2008), 333–355. <https://doi.org/10.1016/j.ijhcs.2007.11.002>
- [11] Fabien Danieau, Philippe Guillotel, Olivier Dumas, Thomas Lopez, Bertrand Leroy, and Nicolas Mollet. 2018. HFX Studio: Haptic Editor for Full-Body Immersive Experiences. In *Proceedings of the 24th ACM Symposium on Virtual Reality Software and Technology (Tokyo, Japan) (VRST '18)*. Association for Computing Machinery, New York, NY, USA, Article 37, 9 pages. <https://doi.org/10.1145/3281505.3281518>
- [12] Donald Degraen, Bruno Fruchard, Frederik Smolders, Emmanouil Potetsianakis, Seref Güngör, Antonio Krüger, and Jürgen Steimle. 2021. Weiriding Haptics: In-Situ Prototyping of Vibrotactile Feedback in Virtual Reality through Vocalization. In *Proceedings of the 34th Annual ACM Symposium on User Interface Software and Technology (Virtual) (UIST '21)*. Association for Computing Machinery, New York, NY, USA. <https://doi.org/10.1145/3472749.3474797>
- [13] Alexandra Delazio, Ken Nakagaki, Jill Fain Lehman, Roberta L. Klatzky, Alanson P. Sample, and Scott E. Hudson. 2018. Force jacket: Pneumatically-actuated jacket for embodied haptic experiences. *Conference on Human Factors in Computing Systems - Proceedings 2018-April* (2018), 1–12. <https://doi.org/10.1145/3173574.3173894>
- [14] M.J. Enriquez and K.E. MacLean. 2003. The haptic editor: a tool in support of haptic communication research. In *HAPTICS '03*. IEEE Comput. Soc, 356–362. <https://doi.org/10.1109/HAPTIC.2003.1191310>
- [15] Colin Gallacher, Arash Mohtat, and Steve Ding. 2016. Toward Open-Source Portable Haptic Displays with Visual-Force-Tactile Feedback Colocation. (2016).
- [16] Frank A. Geldard. 1957. Adventures in tactile literacy. *American Psychologist* 12, 3 (1957), 115–124. <https://doi.org/10.1037/h0040416>
- [17] Eric Gunther, Glorianna Davenport, and Sile O'Modhrain. 2002. Cutaneous grooves: composing for the sense of touch. In *NIME '02*. New York, NY, USA, 73–79. <https://dl.acm.org/citation.cfm?id=1085171.1085181>
- [18] Antal Haans and Wijnand IJsselstein. 2006. Mediated social touch: a review of current research and future directions. *Virtual Reality* 9, 2-3 (2006), 149–159.
- [19] Matthew J Hertenstein, Rachel Holmes, Margaret McCullough, and Dacher Keltner. 2009. The communication of emotion via touch. *Emotion* 9, 4 (2009), 566.
- [20] Lucas Hinderberger. 2020. libvtp: A library for encoding and decoding vibrotactile patterns. <https://github.com/lhinderberger/libvtp> Last accessed 06 July 2021.
- [21] Kristina Höök. 2018. *Designing with the body: Somaesthetic interaction design*. MIT Press.
- [22] Gijs Huisman, Aduén Darriba Frederiks, Betsy Van Dijk, Dirk Hevlen, and Ben Kröse. 2013. The TaSSt: Tactile sleeve for social touch. In *2013 World Haptics Conference (WHC)*. 211–216. <https://doi.org/10.1109/WHC.2013.6548410>
- [23] W.A. A IJsselstein. 2003. Presence in the past: what can we learn from media history? *Being there: concepts, effects and measurements of user presence in synthetic environments* 5 (2003), 17–40.
- [24] Apple inc. 2021. Core Haptics. <https://developer.apple.com/documentation/corehaptics> Last accessed August 1st 2021.
- [25] Interhaptics. 2021. Haptic Composer. <https://www.interhaptics.com/haptic-composer> Last accessed August 1st 2021.
- [26] Yeongmi Kim, Jongeun Cha, Ian Oakley, and Jeha Ryu. 2009. Exploring Tactile Movies: An Initial Tactile Glove Design and Concept Evaluation. *IEEE Multimedia* PP, 99 (2009), 1. <https://doi.org/10.1109/MMUL.2009.63>
- [27] PlatformIO Labs. 2014. Professional collaborative platform for embedded development. <https://platformio.org/> Last accessed 06 July 2021.
- [28] PlatformIO Labs. 2016. Espressif 32: development platform for PlatformIO. <https://github.com/platformio/platform-espressif32> Last accessed 06 July 2021.
- [29] Lofelt. 2021. Lofelt Studio. <https://lofelt.com/design> Last accessed August 1st 2021.
- [30] Emanuela Maggioni, Erika Agostinelli, and Marianna Obrist. 2017. Measuring the added value of haptic feedback. In *2017 Ninth International Conference on Quality of Multimedia Experience (QoMEX)*. 1–6. <https://doi.org/10.1109/QoMEX.2017.7965670>
- [31] Melisa Orta Martinez, Joseph Champion, Tara Gholami, Michal K. Rittikaidachar, Aaron C. Barron, and Allison M. Okamura. 2017. Open source, modular, customizable, 3-D printed kinesthetic haptic devices. *2017 IEEE World Haptics Conference, WHC 2017* (2017), 142–147. <https://doi.org/10.1109/WHC.2017.7989891>
- [32] David J. Meyer, Michael A. Peshkin, and J. Edward Colgate. 2016. Tactile Paintbrush: A procedural method for generating spatial haptic texture. In *2016 IEEE Haptics Symposium (HAPTICS)*. IEEE, 259–264. <https://doi.org/10.1109/HAPTICS.2016.7463187>
- [33] Camille Moussette. 2010. Sketching in Hardware and Building Interaction Design: tools, toolkits and an attitude for Interaction Designers. In *Processing*. <https://public.me.com/intuitive>
- [34] Camille Moussette, Stoffel Kuenen, and Ali Israr. 2012. Designing Haptics. In *Proceedings of the Sixth International Conference on Tangible, Embedded and Embodied Interaction* (Kingston, Ontario, Canada) (TEI '12). Association for Computing Machinery, New York, NY, USA, 351–354. <https://doi.org/10.1145/2148131.2148215>
- [35] Marianna Obrist, Sue Ann Seah, and Sriram Subramanian. 2013. *Talking about Tactile Experiences*. Association for Computing Machinery, New York, NY, USA, 1659–1668. <https://doi.org/10.1145/2470654.2466220>
- [36] Allison M Okamura, Katherine J Kuchenbecker, and Mohsen Mahvash. 2008. Measurement-Based Modeling for Haptic Rendering. In *Haptic Rendering: Algorithms and Applications*. A. K. Peters, Chapter 21, 443–467.
- [37] Sabrina A. Paneels, Margarita Anastassova, and Lucie Brunet. 2013. TactiPED: Easy Prototyping of Tactile Patterns. *INTERACT '13* 8118 (2013), 228–245. <https://doi.org/10.1007/978-3-642-40480-1>
- [38] Evan Pezent, Brandon Cambio, and Marcia K O Malley. 2020. Syntacs: Open Source Framework for Audio-Controlled Vibrotactile Haptics. c (2020), 2020.
- [39] M Pielot, N Henze, and S Boll. 2009. Supporting map-based wayfinding with tactile cues. *Proceedings of the 11th International Conference on Human-Computer Interaction with Mobile Devices and Services MobileHCI 09* (2009), 1. <https://doi.org/10.1145/1613858.1613888>
- [40] Jonghyun Ryu and Seungmoon Choi. 2008. posVibEditor: Graphical authoring tool of vibrotactile patterns. In *HAVE '08*. IEEE, 120–125. <https://doi.org/10.1109/HAVE.2008.4685310>
- [41] Oliver Schneider, Karon MacLean, Colin Swindells, and Kellogg Booth. 2017. Haptic experience design: What hapticians do and where they need help. *International Journal of Human-Computer Studies* 107 (2017), 5–21. <https://doi.org/10.1016/j.ijhcs.2017.04.004> Multisensory Human-Computer Interaction.
- [42] Oliver S. Schneider, Ali Israr, and Karon E. MacLean. 2015. Tactile Animation by Direct Manipulation of Grid Displays. In *UIST '15*.
- [43] Oliver S. Schneider and Karon E. MacLean. 2014. Improvising design with a Haptic Instrument. In *2014 IEEE Haptics Symposium (HAPTICS)*. 327–332. <https://doi.org/10.1109/HAPTICS.2014.6775476>
- [44] Oliver S. Schneider and Karon E. MacLean. 2016. Studying Design Process and Example Use with Macaron, a Web-based Vibrotactile Effect Editor. In *HAPTICS '16: Symposium on Haptic Interfaces for Virtual Environment and Teleoperator Systems*.
- [45] Oliver S. Schneider, Hasti Seifi, Salma Kashani, Matthew Chun, and Karon E. MacLean. 2016. HapTurk: Crowdsourcing Affective Ratings for Vibrotactile Icons. In *CHI '16*. ACM Press, New York, New York, USA, 3248–3260. <https://doi.org/10.1145/2858036.2858279>
- [46] Hasti Seifi, Matthew Chun, Colin Gallacher, Oliver Schneider, and Karon E. MacLean. 2020. How Do Novice Hapticians Design? A Case Study in Creating Haptic Learning Environments. *IEEE Transactions on Haptics* 13, 4 (2020), 791–805. <https://doi.org/10.1109/TOH.2020.2968903>
- [47] Tanay Singhal and Oliver Schneider. 2021. *Juicy Haptic Design: Vibrotactile Embellishments Can Improve Player Experience in Games*. Association for Computing Machinery, New York, NY, USA. <https://doi.org/10.1145/3411764.3445463>
- [48] Katta Spiel. 2021. The Bodies of TEI – Investigating Norms and Assumptions in the Design of Embodied Interaction. In *Proceedings of the Fifteenth International Conference on Tangible, Embedded, and Embodied Interaction (Salzburg, Austria) (TEI '21)*. Association for Computing Machinery, New York, NY, USA, Article 32, 19 pages. <https://doi.org/10.1145/3430524.3440651>
- [49] Katta Spiel and Lennart E. Nacke. 2020. What Is It Like to Be a Game?—Object Oriented Inquiry for Games Research, Design, and Evaluation. *Frontiers in Computer Science* 2 (2020), 18. <https://doi.org/10.3389/fcomp.2020.00018>
- [50] Paul Strohmeier, Seref Güngör, Luis Herres, Dennis Gudea, Bruno Fruchard, and Jürgen Steimle. 2020. BARefoot: Generating Virtual Materials Using Motion Coupled Vibration in Shoes. In *Proceedings of the 33rd Annual ACM Symposium on User Interface Software and Technology (Virtual Event, USA) (UIST '20)*. Association for Computing Machinery, New York, NY, USA, 579–593. <https://doi.org/10.1145/3379337.3415828>
- [51] Colin Swindells, Seppo Pietarinen, and Arto Viitanen. 2014. Medium fidelity rapid prototyping of vibrotactile haptic, audio and video effects. In *2014 IEEE Haptics Symposium (HAPTICS)*. 515–521. <https://doi.org/10.1109/HAPTICS.2014.6775509>
- [52] D Ternes and K E MacLean. 2008. Designing Large Sets of Haptic Icons with Rhythm. *Haptics: Perception, Devices and Scenarios* 5024 (2008), 199–208. <http://www.springerlink.com/index/at15686222k242m4.pdf>
- [53] Marc Teyssier, Gilles Bailly, Éric Lecolinet, and Catherine Pelachaud. 2017. Survey and Perspectives of Social Touch in HCI. In *Proceedings of the 29th Conference on l'Interaction Homme-Machine (Poitiers, France) (IHM '17)*. Association for Computing Machinery, New York, NY, USA, 93–104. <https://doi.org/10.1145/3132129.3132136>
- [54] Graham Wilson and Stephen A. Brewster. 2017. *Multi-Moji: Combining Thermal, Vibrotactile and Visual Stimuli to Expand the Affective Range of Feedback*. Association for Computing Machinery, New York, NY, USA, 1743–1755.

APPENDIX: TACTON EXANPLES

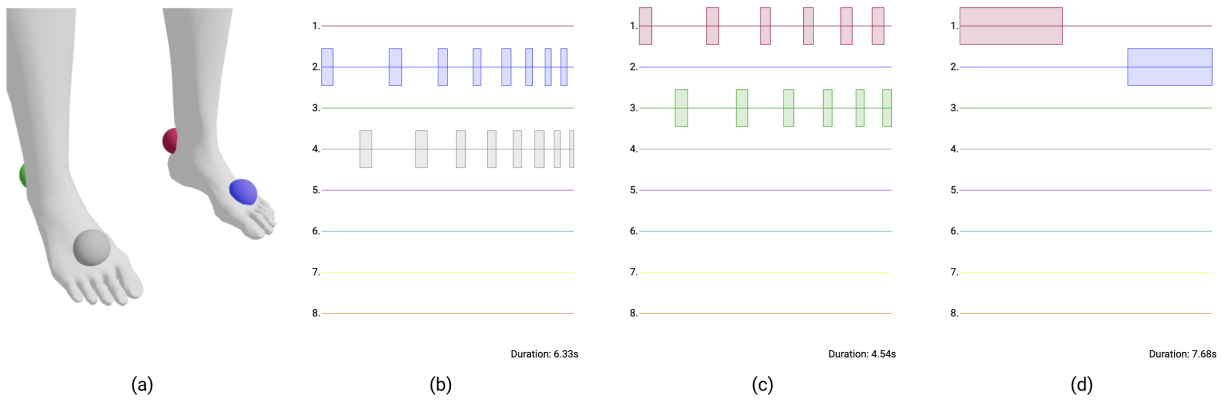

Tactons in the context of *Bicycling*. Participants placed the actuators on the feet (a) to provide instructions to the user, e.g. to speed up (b) and (c) or to slow down (d).

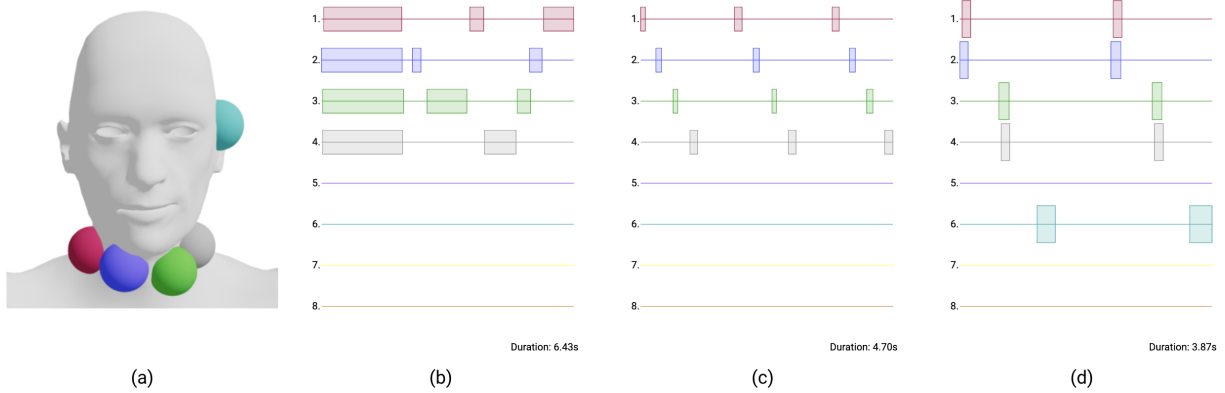

Tactons in the context of *Virtual Reality*. Participants placed the actuators on the head and throat (a) to provide spatial cues for out-of-sight events (b), (c), and (d).

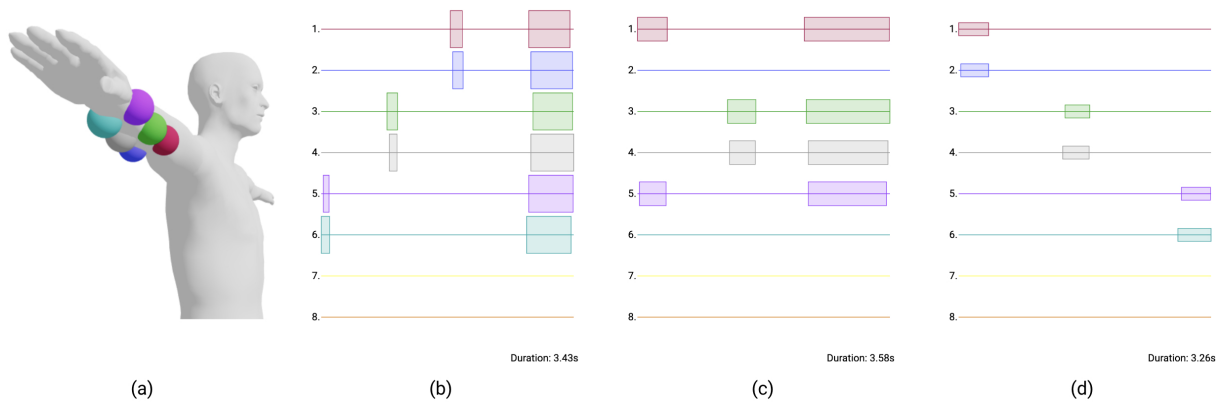

Tactons in the context of *Sports*. Participants placed the actuators on the forearm to indicate certain phases during a physical training, e.g. get ready (b), start (c), and pause/stop (d).