



**HAL**  
open science

## New double column system for heteroazeotropic batch distillation

Ferenc Dénes, Péter Láng, Gabor Modla, Xavier Joulia

► **To cite this version:**

Ferenc Dénes, Péter Láng, Gabor Modla, Xavier Joulia. New double column system for heteroazeotropic batch distillation. *Computers & Chemical Engineering*, 2009, 33 (10), pp.1631-1643. 10.1016/j.compchemeng.2009.01.011 . hal-03563455

**HAL Id: hal-03563455**

**<https://hal.science/hal-03563455>**

Submitted on 9 Feb 2022

**HAL** is a multi-disciplinary open access archive for the deposit and dissemination of scientific research documents, whether they are published or not. The documents may come from teaching and research institutions in France or abroad, or from public or private research centers.

L'archive ouverte pluridisciplinaire **HAL**, est destinée au dépôt et à la diffusion de documents scientifiques de niveau recherche, publiés ou non, émanant des établissements d'enseignement et de recherche français ou étrangers, des laboratoires publics ou privés.



## Open Archive Toulouse Archive Ouverte (OATAO)

OATAO is an open access repository that collects the work of Toulouse researchers and makes it freely available over the web where possible.

This is an author-deposited version published in: <http://oatao.univ-toulouse.fr/>  
Eprints ID: 4998

**To link to this article:** DOI:10.1016/j.compchemeng.2009.01.011  
<http://dx.doi.org/10.1016/j.compchemeng.2009.01.011>

**To cite this version:**

Denes, Ferenc and Lang, Peter and Modla, G. and Joulia, Xavier *New double column system for heteroazeotropic batch distillation*. (2009) *Computers & Chemical Engineering*, vol. 33 (n° 10). pp. 1631-1643. ISSN 0098-1354

Any correspondence concerning this service should be sent to the repository administrator: [staff-oatao@inp-toulouse.fr](mailto:staff-oatao@inp-toulouse.fr)

# New double column system for heteroazeotropic batch distillation

F. Denes<sup>a</sup>, P. Lang<sup>a,\*</sup>, G. Modla<sup>a</sup>, X. Joulia<sup>b</sup>

<sup>a</sup> BUTE Dept. of Building Services & Process Engineering, H-1521 Budapest, Muegyetem rkp. 3-5, Hungary

<sup>b</sup> University of Toulouse, INPT-ENSIACET-LGC, 118 route de Narbonne, 31077 Toulouse Cedex, France

## A B S T R A C T

A new double column system (DCS) operated in closed mode is suggested for heterogeneous batch distillation. This configuration is investigated by feasibility studies based on the assumption of maximal separation and is compared with the traditional batch rectifier (BR). We study the configurations also by dynamic simulation based on a detailed model using a professional simulator. For the new configuration the minimal duration of the process is determined. The influence of the most important operational parameters is studied. The calculations and the simulations are performed for a binary (n-butanol–water) and for a ternary heteroazeotropic mixture (isopropanol–water + benzene as entrainer). One of the advantages of the DCS is that distillation of binary and ternary systems is performed in only one step. Furthermore the recovery of components is usually higher and the amount of byproducts is lower.

### Keywords:

Heteroazeotrope  
Batch distillation  
Feasibility study  
Dynamic simulation  
Double column

## 1. Introduction

The recovery of organic solvents is performed mainly by distillation. In the pharmaceutical and fine chemical industries, batch processes are widely applied because of the low amount and the frequent change of the products. The azeotropic mixtures can be only separated into their pure components by the application of a special distillation method, such as pressure swing, extractive or heteroazeotropic distillation.

The *homoazeotropic mixtures* can be separated without the application of a separating agent by pressure swing distillation if the azeotrope is pressure sensitive. The semicontinuous and batch *pressure swing distillation* was investigated by simulation by Phimister and Seider (2000) and experimentally by Repke, Klein, Bogle, and Wozny (2007). Modla and Lang (2008) suggested two new double column configurations (double column batch rectifier and double column batch stripper) by modifying the middle vessel column. The two-column system was operated in open mode (with continuous withdrawal of products (distillate/bottoms)).

The *homogeneous batch extractive distillation* with the use of a heavy solvent in a rectifier was investigated among others by Lang, Yatim, Moszkowicz, and Otterbein (1994), Duessel and Stichmair (1995), Lelkes, Lang, Benadda, and Moszkowicz (1998), Lang, Kovacs, Kotai, Gaal-Szilagy, and Modla (2006), Kotai, Lang, and Modla (2007) and in a non-conventional configuration (mainly in middle vessel column) among others by Safrit, Westerberg,

Diwekar, and Wahnschafft (1995), Warter and Stichmair (1999), Cui et al. (2002), Low and Sorensen (2002), Warter, Demicoli, and Stichmair (2004), Steger et al. (2006).

If the components of a mixture form a *heteroazeotrope*, or by the addition of an entrainer a heteroazeotrope can be formed, it is possible to cross the azeotropic composition by decantation. The batch heteroazeotropic distillation (BHD) is a widespread industrial method. To our best knowledge so far the process was exclusively applied in the industry in batch rectifiers (equipped with a decanter) in open operation mode (continuous top product withdrawal).

Design and synthesis tools of batch distillation involve the analysis of residue curve maps. Pham and Doherty (1990) described the structure and properties of residue curve maps for ternary heterogeneous azeotropic mixtures. The residue curve map analysis and the subsequent determination of distillation regions consider only the phase equilibrium (VLE) characteristics of the mixture. By extending the method of Pham and Doherty (1990), Lang and Modla (2006) suggested a new general method for the calculation of the residue curves and for the determination of batch distillation regions of the heteroazeotropic distillation. The method considers, in addition to the VLE, operating parameters, such as withdrawal of the entrainer-lean or the entrainer-rich phase or any combination of them as distillate. The above method combines both VLE information and material balances in the same map (still path map).

For the operation mode of batch heteroazeotropic distillation requiring the addition of the lowest amount of entrainer (*E*), the two separation methods (distillation and liquid–liquid phase split) of the hybrid process are applied simultaneously. This operation mode is named Mode II by Skouras, Kiva, and Skogestad (2005) and

\* Corresponding author. Tel.: +36 1 463 1707; fax: +36 1 463 1708.  
E-mail address: lang@mail.bme.hu (P. Lang).

## Nomenclature

$D$	distillate molar flow rate (kmol/s)
$L$	liquid molar flow rate (kmol/s)
$R$	reflux ratio
$SD$	amount of distillate (kmol)
$T$	temperature ( $^{\circ}\text{C}$ )
$t$	time (h)
$U$	liquid holdup (kmol)
$V$	vapour molar flow rate (kmol/h)
$v$	relative vapour flow rate of a column (mol/mol)
$x$	liquid mole fraction
$y$	vapour mole fraction

### Greek letter

$\tau$	duration of the step (h)
--------	--------------------------

### Subscripts

$A$	more volatile component
$AZ$	azeotrope
$B$	less volatile component
$b$	beginning of the step
$BAZ$	binary azeotrope
$ch$	charge
$E$	entrainer
$e$	end of the step
$i, j$	components
$ov$	overall
$res$	residue at the end of the cycle
$spec$	specified value
$TAZ$	ternary azeotrope

### Superscripts

$1$	first step of the operation
$2$	second step of the operation
$Ar, Br$	$A$ -, $B$ -rich phase
$Er$	$E$ -rich phase
$ir, jr$	$i$ -, $j$ -rich phase
$SD$	amount of distillate in the product tank
$\alpha$	$A$ -producing column of the DCS
$\beta$	$B$ -producing column of the DCS

Skouras, Skogestad, and Kiva, (2005). In Mode I the two separation methods are realised in sequence. For Mode II two separation strategies can be realised as presented by Koehler, Haverkamp, and Schadler (1995) and Skouras, Kiva, et al. (2005) and Skouras, Skogestad, et al. (2005). In Strategy A (in the first dehydration step) the  $E$ -rich phase is totally refluxed and in Strategy B only partially refluxed. Obviously Strategy B requires greater amount of entrainer since a considerable part of the entrainer is also withdrawn as distillate. Therefore it provides a competitive alternative to Strategy A only where  $E$  is already present in sufficient quantity in the original ( $A$ - $B$ - $E$  ternary) mixture. For both strategies of operation Mode II, Lang and Modla (2006) suggested to distinguish two versions: (1) the  $E$ -lean phase is not refluxed and (2) the  $E$ -lean phase is also refluxed partially (in order to increase the reflux ratio, if necessary).

The batch rectifier (BR) was investigated with variable decanter holdup by Rodriguez-Donis, Gerbaud, and Joulia (2002) and with continuous entrainer feeding by Modla, Lang, and Molnar (2001) and Modla, Lang, Kotai, and Molnar (2003) and Rodriguez-Donis, Equijarosa, Gerbaud, and Joulia (2003), respectively. Recently the closed operation mode for the BR and also for multivessel columns was extensively studied by Skouras, Kiva, et al. (2005) and Skouras, Skogestad, et al. (2005). Pommier et al. (2008) developed a specific

software architecture based on the BatchColumn<sup>®</sup> simulator and on both SQP (Sequential Quadratic Programming) and GA (Genetic Algorithm) numerical algorithms for the optimisation of sequential batch columns and heterogeneous batch distillation in open mode.

The goals of this paper are:

- to suggest a new double column system (DCS) for the batch heteroazeotropic distillation,
- to investigate this configuration first by feasibility studies then by dynamic simulation based on a more detailed model,
- to compare its performance with that of the traditional BR.

For both configurations we investigated the simultaneous realisation of distillation and liquid-liquid phase split (Mode II). Furthermore we studied only the cases where one-phase streams are led to the top of the column(s) from the decanter.

We compared the optimal operation of the two configurations. The total duration of the process was minimised ( $\min(\Delta t)$ ) by repeated simulations. Since the (total) heat duty was kept constant this means practically minimising the operation costs ( $\min(C_{op})$ ).

The calculations and the simulations were performed for a binary ( $n$ -butanol ( $A$ )-water ( $B$ )) and for a ternary heteroazeotropic mixture (isopropyl-alcohol ( $A$ )-water ( $B$ )+benzene as entrainer ( $E$ )). For the simulation we used the dynamic simulator of CHEMCAD 5.6 (module CC-DCOLUMN, Chemstations, 2007).

## 2. The column configurations studied

First the operation of the BR then that of the new double column system (DCS) will be presented. For the sake of simplicity we assume maximal separation for both configurations, that is, in each column the top vapour has always azeotropic composition.

### 2.1. Batch rectifier

First the separation of the binary then that of the ternary mixture is presented.

#### 2.1.1. Separation of the binary mixture (Fig. 1)

If the feed (charge) composition  $x_{ch,A}$  is in the heterogeneous region ( $x_{AZ,A}^{Br} < x_{ch,A} < x_{AZ,A}^{Ar}$ ), it is worth to separate it by decantation into an  $A$ -rich ( $x_{AZ,A}^{Ar}$ ) and a  $B$ -rich ( $x_{AZ,A}^{Br}$ ) phase before the start of the distillation.

One production cycle consists of two distillation steps. We select the phase to be distilled in the first step so that the overall quantity of the two products in the first cycle be maximal. By assuming

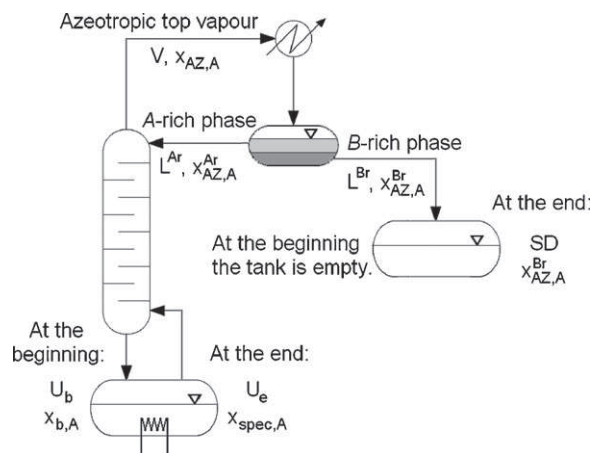

Fig. 1. Batch rectifier producing A from a binary mixture.

maximal separation from the material balances it can be derived (for pure products) that we have to distil the A-rich phase first if

$$x_{ch,A} > \frac{x_{AZ,A}^{Br}}{1 - (x_{AZ,A}^{Ar} - x_{AZ,A}^{Br})} \quad (1)$$

**Step 1. Production of A:** The A-rich phase ( $x_{AZ,A}^{Ar}$ ) of the heteroazeotrope ( $x_{AZ,A}$ ) is refluxed and the B-rich one ( $x_{AZ,A}^{Br}$ ) is withdrawn as distillate. The bottom residue is product A.

**Step 2. Production of B:** The B-rich phase(s) is (are) distilled. The B-rich phase of the azeotrope is refluxed and the A-rich one is withdrawn as distillate. The bottom residue is product B.

We can state that the main disadvantages of the BR are:

- in one step only one pure component can be produced (in the residue) and
- the recovery is limited since the other component in the distillate is always saturated with this component.

### 2.1.2. Separation of the ternary mixture

A homoazeotropic binary alcohol (A)–water (B) mixture is considered, which cannot be separated by ordinary rectification. Hence the addition of a third component (entrainer, E) is needed, usually in a small amount. E is partially miscible with B but totally miscible with A. The steps of a production cycle are as follows:

**Step 1. Production of A (Fig. 2a):** The E-rich organic phase ( $\vec{x}_{TAZ}^{Er}$ ) of the ternary azeotrope ( $\vec{x}_{TAZ}$ ) is refluxed and the B-rich aqueous phase ( $\vec{x}_{TAZ}^{Br}$ ) is withdrawn as distillate. The bottom residue is product A. The distillate is processed in Step 2.

**Step 2. Removal of E (Fig. 2b):** The B-rich phase of the azeotrope is refluxed and the E-rich phase is withdrawn as distillate. The bottom residue still contains some A.

**Step 3. Purification of B from A (Fig. 2c):** In this step a homogeneous mixture is processed, thus there is no need for a decanter. A is removed (from the bottom residue of Step 2) in the form of binary A–B homoazeotrope ( $\vec{x}_{BAZ}$ ) in the distillate and the bottom residue is product B.

## 2.2. The new double column system

The DCS is operated in closed mode (without continuous product withdrawal). The two columns are equipped with a single, common decanter. Two components are simultaneously produced as bottom residues.

### 2.2.1. Separation of the binary mixture (Fig. 3)

If the charge composition is in the heterogeneous region similarly to the BR it is worth to separate it by decantation. Contrary to the BR both phases are filled into the reboilers. The A-rich phase is filled in the reboiler of the column  $\alpha$  (producing A) and a B-rich one to the other reboiler  $\beta$ .

If the feed is homogeneous the charge must be divided between the two reboilers. The top vapour of both columns is of azeotropic composition. The A-rich phase is sent to the top of column  $\alpha$  and the B-rich one is fed to the top of column  $\beta$ . In one operation step we obtain product A (of prescribed purity  $x_{spec,A}$ ) in the reboiler  $\alpha$  and product B (of prescribed purity  $x_{spec,B}$ ) in the reboiler  $\beta$ , respectively.

### 2.2.2. Separation of the ternary mixture (Fig. 4)

The homogeneous charge must be divided between the two reboilers. The entrainer, which is filled at the start only in the reboiler of column  $\alpha$ , circulates in the system. The amount of E is negligible hence its mole fraction is zero in both reboilers during the

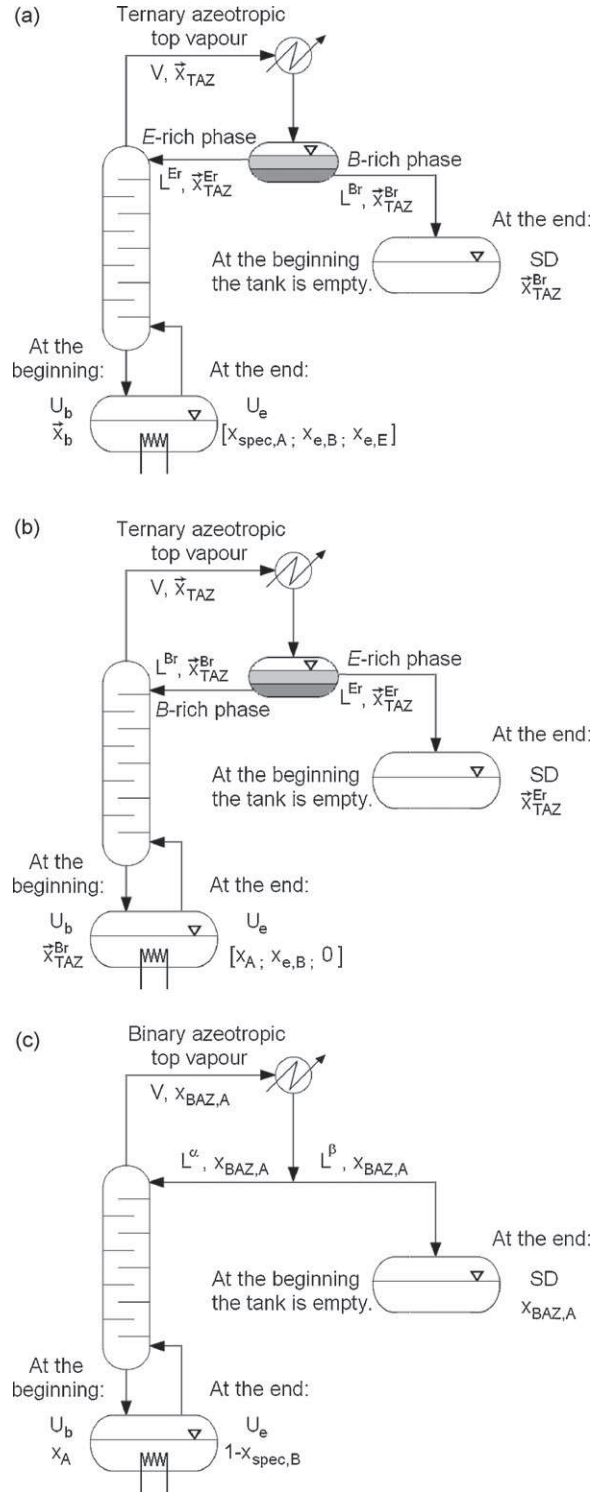

**Fig. 2.** (a) Batch rectifier: production of A from mixture A–B + E in Step 1. (b) Batch rectifier: removal of E in Step 2 (from the distillate of Step 1). (c) Batch rectifier: production of B in Step 3 (from the residue of Step 2).

whole process. The top vapour of the column  $\alpha$  is ternary azeotrope and that of column  $\beta$  is binary azeotrope A–B. The E-rich phase is sent to the top of column  $\alpha$  and the B-rich one (containing negligible amount of E) is fed to the top of column  $\beta$ . It is unnecessary to fill E into the reboiler  $\beta$  because the B-rich phase of the decanter (mixture of the binary (A–B) and ternary azeotrope) contains more B than the binary azeotropic top vapour of column  $\beta$ . That is B can

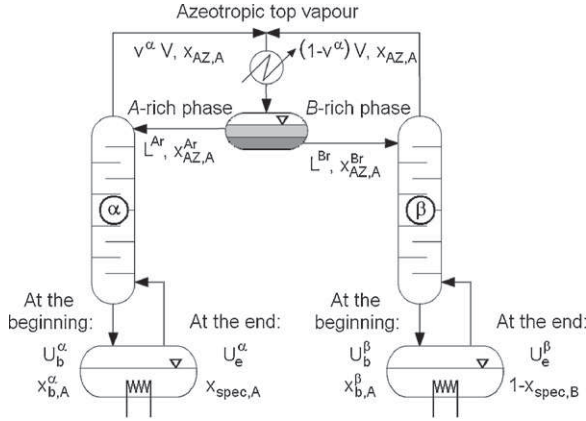

Fig. 3. Operation of the double column configuration for the binary mixture.

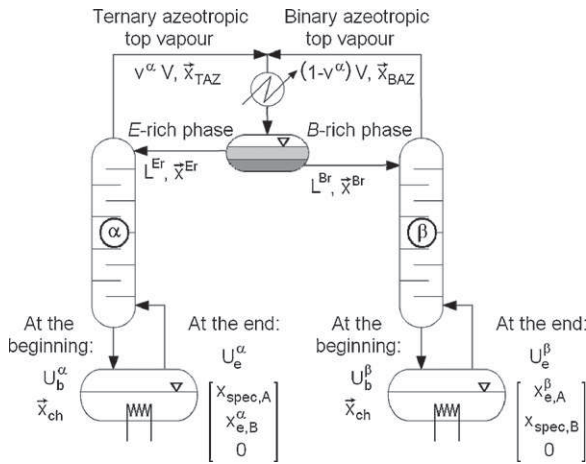

Fig. 4. Operation of the double column configuration for the ternary mixture.

be purified even without adding E.

### 3. Feasibility method

Our aim is to estimate the duration of the processes, the amount of the products and that of the byproducts. A simplified model was applied based on the following assumptions:

- maximal separation,
- negligible holdup on the trays and in the decanter,
- constant molar overflow,
- the flow rates do not vary with the time,
- one-phase liquid streams leave the decanter,
- negligible duration of pumping between the operation steps (BR),
- no entrainer loss (in the case of the ternary mixture).

The total (TMB) and component material (CMB) balance equations for one column and the decanter are analytically solved. For the DCS we assume that both products reach the prescribed purity at the same time, that is, the duration is minimal. The process time ( $\tau$ ) for both configurations and for the DCS the optimal division ( $\nu^\alpha$ ) of total vapour flow rate ( $V$ ) between the two reboilers and that of the charge ( $U_b^\alpha/U_{ch}$ ) are calculated.

### 3.1. Model equations for the batch rectifier

#### 3.1.1. Separation of the binary mixture (Fig. 1)

Integral material balances for the given step:

$$\text{TMB} : U_b = U_e + \text{SD} \quad (2)$$

$$\text{CMB} : U_b x_{b,i} = U_e x_{\text{spec},i} + \text{SD} x_{e,i}^{\text{SD}} \quad (3)$$

where 'i' denotes the component produced in the given step.

Differential material balances for the column:

DTMB:

$$\frac{dU}{dt} = -V + L^{\text{ir}} \quad (4)$$

Boundary conditions:

$$U(0) = U_b \quad (4a)$$

$$U(\tau) = U_e \quad (4b)$$

Hence

$$U_e = U_b + (-V + L^{\text{ir}})\tau \quad (4c)$$

DCMB:

$$\frac{d(Ux_i)}{dt} = -Vx_{\text{AZ},i} + L^{\text{ir}}x_{\text{AZ},i}^{\text{ir}} \quad (5)$$

Boundary conditions:

$$(Ux_i)(0) = U_b x_{b,i} \quad (5a)$$

$$(Ux_i)(\tau) = U_e x_{\text{spec},i} \quad (5b)$$

Hence

$$U_e x_{\text{spec},i} = U_b x_{b,i} + (-Vx_{\text{AZ},i} + L^{\text{ir}}x_{\text{AZ},i}^{\text{ir}})\tau \quad (5c)$$

Differential material balances for the decanter:

$$\text{DTMB} : \frac{dU^{\text{dec}}}{dt} = V - L^{\text{ir}} - L^{\text{jr}} = 0 \quad (6)$$

$$\text{DCMB} : \frac{d(U^{\text{dec}}x_i^{\text{dec}})}{dt} = Vx_{\text{AZ},i} - L^{\text{ir}}x_{\text{AZ},i}^{\text{ir}} - L^{\text{jr}}x_{\text{AZ},i}^{\text{jr}} = 0 \quad (7)$$

Known parameters:  $U_b, V, x_{b,i}, x_{\text{spec},i}, x_{\text{AZ},i}, x_{\text{AZ},i}^{\text{ir}}, x_{\text{AZ},i}^{\text{jr}}$ .

Unknowns:  $U_e, \text{SD}, x_{e,i}^{\text{SD}}, \tau, L^{\text{ir}}, L^{\text{jr}}$ .

Number of independent equations: 6 ((2)–(7) without equations -a, -b and -c).

Number of unknowns: 6.

Degree of freedom: 0.

If we produce component A first, the known parameters have the following values:

Step 1.  $i=A, j=B$ ; if the charge is homogeneous:  $U_b = U_{\text{ch}}, x_{b,i} = x_{\text{ch},A}$ ,

if the charge is heterogeneous:  $U_b = U_{\text{AZ},A}^{\text{Ar}}, x_{b,i} = x_{\text{AZ},A}^{\text{Ar}}$ .

Step 2.  $i=B, j=A$ ; if the charge is homogeneous:  $U_b = \text{SD}, x_{b,i} = x_{\text{AZ},B}^{\text{Br}}$ ,

if the charge is heterogeneous:  $U_b = \text{SD} + U_{\text{AZ},B}^{\text{Br}}, x_{b,i} = x_{\text{AZ},B}^{\text{Br}}$ .

The solution of the set of Eqs. (2)–(7):

$$\text{Duration of the step: } \tau = \frac{(x_{\text{AZ},i}^{\text{ir}} - x_{\text{AZ},i}^{\text{jr}})(x_{e,i} - x_{b,i})}{(x_{\text{AZ},i}^{\text{ir}} - x_{\text{AZ},i})(x_{e,i} - x_{\text{AZ},i}^{\text{ir}})} \cdot \frac{U_b}{V}.$$

$$\text{Further results: } L^{\text{ir}} = \frac{x_{\text{AZ},i} - x_{\text{AZ},i}^{\text{ir}}}{x_{\text{AZ},i}^{\text{ir}} - x_{\text{AZ},i}} \cdot V, L^{\text{jr}} = V - L^{\text{ir}}, U_e = \frac{x_{b,i} - x_{\text{AZ},i}^{\text{ir}}}{x_{e,i} - x_{\text{AZ},i}^{\text{ir}}} \cdot U_b,$$

$$\text{SD} = U_{\text{ch}} - U_e, x_{e,i}^{\text{SD}} = x_{\text{AZ},i}^{\text{jr}}.$$

### 3.1.2. Separation of the ternary mixture

3.1.2.1. *Step 1 (Fig. 2a)*. We suppose that product A does not contain E (it is contaminated only by B) and that the amount of E in the B-rich phase of the heteroazeotrope can be neglected.

Integral material balances:

$$\text{TMB} : U_{\text{ch}} = U_e + \text{SD} \quad (8)$$

$$\text{CMB} : U_{\text{ch}}x_{\text{ch},A} = U_e x_{\text{spec},A} + \text{SD} x_{e,A}^{\text{SD}} \quad (9)$$

Differential material balances for the column:

DTMB:

$$\frac{dU}{dt} = -V + L^{\text{Er}} \quad (10)$$

Boundary conditions:

$$U(0) = U_b \quad (10a)$$

$$U(\tau) = U_e \quad (10b)$$

Hence

$$U_e = U_{\text{ch}} + (-V + L^{\text{Er}})\tau \quad (10c)$$

DCMB:

$$\frac{d(Ux_A)}{dt} = -Vx_{\text{Taz},A} + L^{\text{Er}}x_{\text{Taz},A}^{\text{Er}} \quad (11)$$

Boundary conditions:

$$(Ux_A)(0) = U_{\text{ch}}x_{\text{ch},A} \quad (11a)$$

$$(Ux_A)(\tau) = U_e x_{\text{spec},A} \quad (11b)$$

Hence

$$U_e x_{\text{spec},A} = U_{\text{ch}}x_{\text{ch},A} + (-Vx_{\text{Taz},A} + L^{\text{Er}}x_{\text{Taz},A}^{\text{Er}})\tau \quad (11c)$$

Differential material balances for the decanter:

$$\text{DTMB} : \frac{dU^{\text{dec}}}{dt} = V - L^{\text{Er}} - L^{\text{Br}} = 0 \quad (12)$$

$$\text{DCMB} : \frac{d(U^{\text{dec}}x_A^{\text{dec}})}{dt} = Vx_{\text{Taz},A} - L^{\text{Er}}x_{\text{Taz},A}^{\text{Er}} - L^{\text{Br}}x_{\text{Taz},A}^{\text{Br}} = 0 \quad (13)$$

Known parameters:  $U_{\text{ch}}, V, x_{\text{spec},A}, x_{\text{ch},A}, x_{\text{Taz},A}, x_{\text{Taz},A}^{\text{Er}}, x_{\text{Taz},A}^{\text{Br}}$ .

Unknowns:  $U_e, \text{SD}, x_{e,A}^{\text{SD}}, \tau, L^{\text{Er}}, L^{\text{Br}}$ .

Number of independent equations: 6 ((8)–(13) without equations -a, -b and -c).

Number of unknowns: 6.

Degree of freedom: 0.

The solution of the set of Eqs. (8)–(13):

Duration of the step:  $\tau = ((x_{\text{Taz},A}^{\text{Er}} - x_{\text{Taz},A}^{\text{Br}})(x_{\text{spec},A} - x_{\text{ch},A})) / ((x_{\text{Taz},A}^{\text{Er}} - x_{\text{Taz},A}^{\text{Br}})(x_{\text{spec},A} - x_{\text{Taz},A}^{\text{Br}}))(U_{\text{ch}}/V)$ .

Further results:  $L^{\text{Er}} = (x_{\text{Taz},A} - x_{\text{Taz},A}^{\text{Br}}/x_{\text{Taz},A}^{\text{Er}} - x_{\text{Taz},A}^{\text{Br}})V$ ,  $L^{\text{Br}} = V - L^{\text{Er}}$ ,  $U_e = (x_{\text{ch},A} - x_{\text{Taz},A}^{\text{Er}}/x_{\text{spec},A} - x_{\text{Taz},A}^{\text{Br}})U_{\text{ch}}$ ,  $\text{SD} = U_{\text{ch}} - U_e$ ,  $x_{e,A}^{\text{SD}} = x_{\text{AZ},A}^{\text{Br}}$ .

3.1.2.2. *Step 2 (Fig. 2b)*. The top vapour has ternary azeotropic composition. In the end of the step only IPA–water binary mixture remains in the reboiler.

Integral material balances:

$$\text{TMB} : U_b = U_e + \text{SD} \quad (14)$$

$$\text{CMB} : U_b x_{\text{Taz},E}^{\text{Br}} = \text{SD} x_{\text{Taz},E}^{\text{Er}} \quad (15)$$

$$\text{CMB} : U_b x_{\text{Taz},A}^{\text{Br}} = U_e x_{e,A} + \text{SD} x_{\text{Taz},A}^{\text{Er}} \quad (16)$$

Differential material balances for the column:

DTMB:

$$\frac{dU}{dt} = -V + L^{\text{Br}} \quad (17)$$

Boundary conditions:

$$U(0) = U_b \quad (17a)$$

$$U(\tau) = U_e \quad (17b)$$

Hence

$$U_e = U_b + (-V + L^{\text{Br}})\tau \quad (17c)$$

Differential material balances for the decanter:

$$\text{DTMB} : \frac{dU^{\text{dec}}}{dt} = V - L^{\text{Er}} - L^{\text{Br}} = 0 \quad (18)$$

$$\text{DCMB} : \frac{d(U^{\text{dec}}x_A^{\text{dec}})}{dt} = Vx_{\text{Taz},A} - L^{\text{Er}}x_{\text{Taz},A}^{\text{Er}} - L^{\text{Br}}x_{\text{Taz},A}^{\text{Br}} = 0 \quad (19)$$

Known parameters:  $U_b, V, \vec{x}_{\text{Taz}}, \vec{x}_{\text{Taz}}^{\text{Er}}, \vec{x}_{\text{Taz}}^{\text{Br}}$ .

Unknowns:  $U_e, \text{SD}, x_{e,A}, \tau, L^{\text{Er}}, L^{\text{Br}}$ .

Number of independent equations: 6 ((14)–(19) without equations -a, -b and -c).

Number of unknowns: 6.

Degree of freedom: 0.

The solution of the set of Eqs. (14)–(19):

Duration of the step:  $\tau = (x_{\text{Taz},A}^{\text{Er}} - x_{\text{Taz},A}^{\text{Br}}/x_{\text{Taz},A} - x_{\text{Taz},A}^{\text{Br}})(x_{\text{Taz},E}^{\text{Br}}/x_{\text{Taz},E}^{\text{Er}})(U_b/V)$ .

Further results:  $L^{\text{Er}} = (x_{\text{Taz},A} - x_{\text{Taz},A}^{\text{Br}}/x_{\text{Taz},A}^{\text{Er}} - x_{\text{Taz},A}^{\text{Br}})V$ ,  $L^{\text{Br}} = V - L^{\text{Er}}$ ,  $U_e = (x_{\text{Taz},E}^{\text{Er}} - x_{\text{Taz},E}^{\text{Br}}/x_{\text{Taz},E}^{\text{Er}})U_b$ ,  $\text{SD} = U_e - U_b$ ,  $x_{e,A} = (x_{\text{Taz},E}^{\text{Er}}x_{\text{Taz},A} - x_{\text{Taz},E}^{\text{Br}}x_{\text{Taz},A}^{\text{Br}})/(x_{\text{Taz},E}^{\text{Er}} - x_{\text{Taz},E}^{\text{Br}})$ .

3.1.2.3. *Step 3 (Fig. 2c)*. In this step only A and B are present, the top vapour is the homoazeotrope. There is no need for a decanter.

Integral material balances:

$$\text{TMB} : U_b = U_e + \text{SD} \quad (20)$$

$$\text{CMB} : U_b x_1 = U_e(1 - x_{\text{spec},2}) + \text{SD} x_{\text{BAZ},A} \quad (21)$$

Differential material balances for the column:

DTMB:

$$\frac{dU}{dt} = -V + \frac{R}{1+R}V \quad (22)$$

Boundary conditions:

$$U(0) = U_b \quad (22a)$$

$$U(\tau) = U_e \quad (22b)$$

Hence

$$U_e = U_b - \frac{1}{1+R}V\tau \quad (22c)$$

Known parameters:  $U_b, V, x_{b,A}, x_{\text{spec},B}, x_{\text{BAZ},A}$ .

Unknowns:  $U_e, \text{SD}, \tau, R$ .

Number of independent equations: 3 ((20)–(22) without equations -a, -b and -c).

Number of unknowns: 4.

Degree of freedom: 1.

Let us consider R as an operational parameter.

The solution of the set of Eqs. (20)–(22):

Duration of the step:  $\tau = ((x_{b,A} - (1 - x_{\text{spec},B}))/x_{\text{BAZ},A} - (1 - x_{\text{spec},B}))(1 + R)(U_b/V)$ .

Further results:  $U_e = \frac{x_{\text{BAZ},A} - x_{b,A}}{x_{\text{BAZ},A} - (1 - x_{\text{spec},B})} U_b$ ;  $SD = U_e - U_b$ .

### 3.2. Model equations for the double column system

The model equations are presented first for the separation of the binary mixture and then for that of the ternary one.

#### 3.2.1. Separation of the binary mixture (Fig. 3)

Integral material balances for the whole system (for the whole process):

TMB:

$$U_b^\alpha + U_b^\beta = U_{\text{ch}} \quad (23)$$

$$U_e^\alpha + U_e^\beta = U_{\text{ch}} \quad (24)$$

CMB:

$$U_b^\alpha x_{b,A}^\alpha + U_b^\beta x_{b,A}^\beta = U_{\text{ch}} x_{\text{ch},A} \quad (25)$$

$$U_e^\alpha x_{\text{spec},A} + U_e^\beta (1 - x_{\text{spec},B}) = U_{\text{ch}} x_{\text{ch},A} \quad (26)$$

Differential material balances for the column  $\alpha$ :

DTMB:

$$\frac{dU^\alpha}{dt} = -v^\alpha V + L^{\text{Ar}} \quad (27)$$

Boundary conditions:

$$U^\alpha(0) = U_b^\alpha \quad (27a)$$

$$U^\alpha(\tau) = U_e^\alpha \quad (27b)$$

Hence

$$U_e^\alpha = U_b^\alpha + (-v^\alpha V + L^{\text{Ar}})\tau \quad (27c)$$

DCMB:

$$\frac{d(U^\alpha x_A^\alpha)}{dt} = -v^\alpha V x_{\text{AZ},A} + L^{\text{Ar}} x_{\text{AZ},A}^{\text{Ar}} \quad (28)$$

Boundary conditions:

$$(U^\alpha x_A^\alpha)(0) = U_b^\alpha x_{b,A}^\alpha \quad (28a)$$

$$(U^\alpha x_A^\alpha)(\tau) = U_e^\alpha x_{\text{spec},A} \quad (28b)$$

Hence

$$U_e^\alpha x_{\text{spec},A} = U_b^\alpha x_{b,A}^\alpha + (-v^\alpha V x_{\text{AZ},A} + L^{\text{Ar}} x_{\text{AZ},A}^{\text{Ar}})\tau \quad (28c)$$

Differential material balances for the decanter:

$$\text{DTMB: } \frac{dU^{\text{dec}}}{dt} = V - L^{\text{Ar}} - L^{\text{Br}} = 0 \quad (29)$$

$$\text{DCMB: } \frac{d(U^{\text{dec}} x_A^{\text{dec}})}{dt} = V x_{\text{AZ},A} - L^{\text{Ar}} x_{\text{AZ},A}^{\text{Ar}} - L^{\text{Br}} x_{\text{AZ},A}^{\text{Br}} = 0 \quad (30)$$

Known parameters:  $U_{\text{ch}}, V, x_{\text{spec},A}, x_{\text{spec},B}, x_{\text{AZ}}, x_{\text{AZ}}^{\text{Ar}}, x_{\text{AZ}}^{\text{Br}}$ .

Unknowns:  $U_b^\alpha, U_b^\beta, U_e^\alpha, U_e^\beta, v^\alpha, T, L^{\text{Ar}}, L^{\text{Br}}$ .

If the charge is heterogeneous:  $x_{b,A}^\alpha = x_{\text{AZ},A}^{\text{Ar}}$  and  $x_{b,A}^\beta = x_{\text{AZ},A}^{\text{Br}}$ .

Number of independent equations: 8 ((23)–(30) without equations -a, -b and -c).

Number of unknowns: 8.

Degree of freedom: 0.

If the charge is homogeneous:  $x_{b,A}^\alpha = x_{b,A}^\beta = x_{\text{ch},A}$ , thus Eq. (25) is identical to Eq. (23), hence one of the unknowns ( $U_b^\alpha, U_b^\beta, v^\alpha$ ) must

be specified.

Number of independent equations: 7.

Number of unknowns: 8.

Degree of freedom: 1.

The solution of the set of Eqs. (23)–(30):

$$\text{Duration of the step: } \tau = \frac{\Delta(U^\alpha x_A^\alpha) - \Delta U^\alpha x_{\text{AZ},A}}{x_{\text{AZ},A}^{\text{Ar}} - x_{\text{AZ},A}} \frac{1}{L^{\text{Ar}}}$$

where  $\Delta U^\alpha = U_e^\alpha - U_b^\alpha$  and  $\Delta(U^\alpha x_A^\alpha) = U_e^\alpha x_{\text{spec},A} - U_b^\alpha x_{b,A}^\alpha$ .

Optimal division of the heterogeneous charge :

$$U_b^\alpha = \frac{x_{\text{ch},A} - x_{b,A}^{\text{Br}}}{x_{b,A}^{\text{Ar}} - x_{b,A}^{\text{Br}}} U_{\text{ch}}; \quad U_b^\beta = U_{\text{ch}} - U_b^\alpha$$

Optimal division of the vapour flow rate :

$$v^\alpha = \frac{\Delta(U^\alpha x_A^\alpha) - \Delta U^\alpha x_{\text{AZ},A}^{\text{Ar}}}{\Delta(U^\alpha x_A^\alpha) - \Delta U^\alpha x_{\text{AZ},A}} \frac{L^{\text{Ar}}}{V}$$

Further results:  $L^{\text{Ar}} = \frac{x_{\text{AZ},A} - x_{\text{AZ},A}^{\text{Br}}}{x_{\text{AZ},A}^{\text{Ar}} - x_{\text{AZ},A}^{\text{Br}}} V$ ,  $L^{\text{Br}} = V - L^{\text{Ar}}$ ;  $U_e^\alpha = \frac{x_{\text{ch},A} - (1 - x_{\text{spec},B})}{x_{\text{spec},A} - (1 - x_{\text{spec},B})} U_{\text{ch}}$ ,  $U_e^\beta = U_{\text{ch}} - U_e^\alpha$ .

#### 3.2.2. Separation of a ternary mixture (Fig. 4)

Initially only the reboiler  $\alpha$  contains  $E$ . We neglect the content of  $E$  of the  $B$ -rich phase. Hence there is no  $E$  in column  $\beta$  whose top vapour is  $A$ - $B$  binary azeotrope.

Integral material balances for the whole system:

TMB:

$$U_b^\alpha + U_b^\beta = U_{\text{ch}} \quad (31)$$

$$U_e^\alpha + U_e^\beta = U_{\text{ch}} \quad (32)$$

CMB:

$$U_{\text{ch}} x_{\text{ch},A} = U_e^\alpha x_{\text{spec},A} + U_e^\beta (1 - x_{\text{spec},B}) \quad (33)$$

Differential material balances for the column  $\alpha$ :

DTMB:

$$\frac{dU^\alpha}{dt} = -v^\alpha V + L^{\text{Er}} \quad (34)$$

Boundary conditions:

$$U^\alpha(0) = U_b^\alpha \quad (34a)$$

$$U^\alpha(\tau) = U_e^\alpha \quad (34b)$$

Hence

$$U_e^\alpha = U_b^\alpha + (-v^\alpha V + L^{\text{Er}})\tau \quad (34c)$$

DCMB:

$$\frac{d(U^\alpha x_A^\alpha)}{dt} = -v^\alpha V x_{\text{Taz},A} + L^{\text{Er}} x_A^{\text{Er}} \quad (35)$$

Boundary conditions:

$$(U^\alpha x_A^\alpha)(0) = U_b^\alpha x_{\text{ch},A} \quad (35a)$$

$$(U^\alpha x_A^\alpha)(\tau) = U_e^\alpha x_{\text{spec},A} \quad (35b)$$

Hence

$$U_e^\alpha x_{\text{spec},A} = U_b^\alpha x_{\text{ch},A} + (-v^\alpha V x_{\text{Taz},A} + L^{\text{Er}} x_A^{\text{Er}})\tau \quad (35c)$$



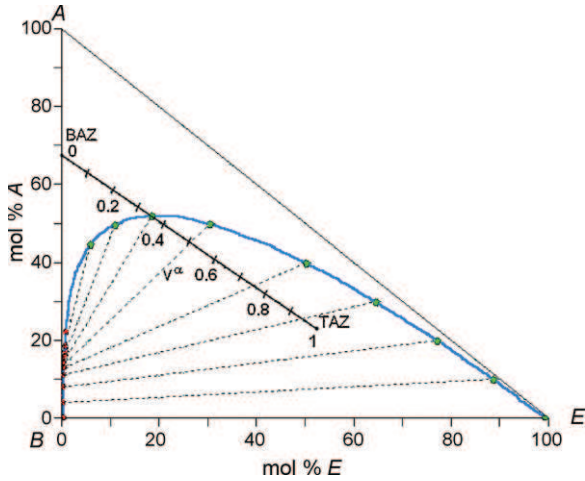

Fig. 5. Composition of the liquid in the decanter as the function of the relative vapour flow rate of column  $\alpha$ .

Differential material balances for the decanter:

$$\text{DTMB: } \frac{dU^{\text{dec}}}{dt} = V - L^{\text{Er}} - L^{\text{Br}} = 0 \quad (36)$$

$$\text{DCMB: } \frac{d(U^{\text{dec}}x_E^{\text{dec}})}{dt} = Vx_{\text{TAZ},E} - L^{\text{Er}}x_E^{\text{Er}} = 0 \quad (37)$$

Overall composition of the liquid in the decanter:

$$\vec{x}_{\text{ov}} = v^\alpha \vec{x}_{\text{TAZ}} + (1 - v^\alpha) \vec{x}_{\text{BAZ}} \quad (38)$$

Composition of the E-rich phase leaving the decanter:

$$x_A^{\text{Er}} = f_1(\vec{x}_{\text{ov}}) \quad (39)$$

$$x_E^{\text{Er}} = f_2(\vec{x}_{\text{ov}}) \quad (40)$$

Known parameters:  $U_{\text{ch}}, x_{\text{ch},A}, V, x_{\text{spec},A}, x_{\text{spec},B}, \vec{x}_{\text{TAZ}}, \vec{x}_{\text{BAZ}}, \vec{x}_{\text{ov}}$ .

Unknowns:  $U_b^\alpha, U_b^\beta, U_e^\alpha, U_e^\beta, v^\alpha, \tau, L^{\text{Er}}, L^{\text{Br}}, x_A^{\text{Er}}, x_E^{\text{Er}}, \vec{x}_{\text{ov}}$ .

Number of independent equations: 10 ((31)–(40) without equations -a, -b and -c).

Number of unknowns: 11.

Degree of freedom: 1.

Eqs. (39) and (40) describe the composition of the E-rich phase of the heterogeneous ternary mixture in the decanter. The composition of the liquid phases depends on the overall composition and on the location of the solubility curve (Fig. 5). Although the overall composition depends linearly on  $v^\alpha$  (Eq. (38)) but the solubility curve is highly non-linear (because of the complexity of the activity coefficient models used for the description of the liquid–liquid equilibrium). This set of equations cannot be solved analytically, only numerically. Hence  $v^\alpha$  is considered as an operational parameter which makes possible to calculate separately the composition of the liquid phases (Eqs. (38)–(40)) from Eqs. (31)–(37).

The solution of the set of Eqs. (31)–(37):

$$\text{Duration of the step: } \tau = \frac{U_e^\alpha(x_{\text{spec},A} - x_{\text{ch},A})}{L^{\text{Er}}(x_A^{\text{Er}} - x_{\text{ch},A}) + v^\alpha V(x_{\text{ch},A} - x_{\text{TAZ},A})}$$

Optimal division of the charge:

$$U_e^\alpha = \frac{x_{\text{ch},A} - (1 - x_{\text{spec},B})}{x_{\text{spec},A} - (1 - x_{\text{spec},B})} U_{\text{ch}}$$

$$U_e^\beta = U_{\text{ch}} - U_e^\alpha$$

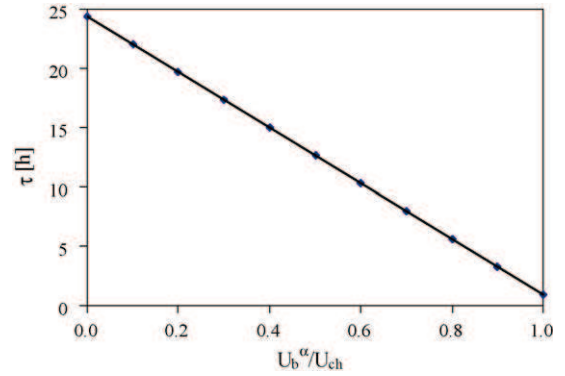

Fig. 6. Duration of the process for different divisions of the charge (simplified model).

Further results:  $L^{\text{Er}} = \frac{x_{\text{TAZ},E}}{x_E^{\text{Er}}} v^\alpha V$ ,  $L^{\text{Br}} = V - L^{\text{Er}}$ ,  $U_b^\alpha = U_e^\alpha + (v^\alpha V - L^{\text{Er}})\tau$ ,  $U_b^\beta = U_{\text{ch}} - U_b^\alpha$ .

#### 4. Calculation results of the feasibility studies

The heat duty is proportional to the vapour flow rate. The total vapour flow rate of the DCS is taken equal to that of the BR ( $V = 20 \text{ kmol/h}$ ) in order to have the same operating costs for the DCS and BR. For the DCS we determine the optimal division of the charge between the two reboilers (and the division of the total vapour flow rate belonging to it). In all cases the amount of charge is 100 kmol and the specified purity ( $x_{\text{spec},i}$ ) is 99.5 mol% for both products.

##### 4.1. Separation of the binary mixture (*n*-butanol (A)–water (B))

The composition of the heteroazeotrope and those of the A-rich and B-rich phases are, respectively:

$$\vec{x}_{\text{AZ}} = [0.2562, 0.7438], \quad \vec{x}_{\text{AZ}}^{\text{Ar}} = [0.568, 0.432],$$

$$\vec{x}_{\text{AZ}}^{\text{Br}} = [0.012, 0.988]$$

All possible cases are studied: two homogeneous charges (one rich in A and the other rich in B) and a heterogeneous one.

##### 4.1.1. A homogeneous charge rich in A ( $\vec{x}_{\text{ch}} = [0.9, 0.1]$ )

a. Batch rectifier:

In Step 1 A is produced and in Step 2 B is produced (Table 1).

b. Double column system:

We determine  $\tau$  and  $v^\alpha$  for different ratios of division of the charge  $U_b^\alpha/U_{\text{ch}}$  (Figs. 6–7). The best operational policy (Table 1)

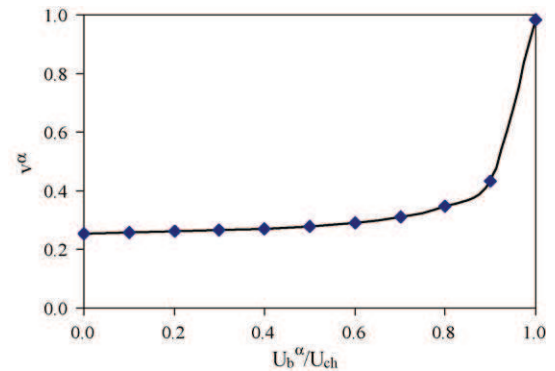

Fig. 7. Relative vapour flow rate of column  $\alpha$  for different divisions of the charge (simplified model).

**Table 1**  
Results for the binary mixture of different compositions (simplified model).

	BR			DCS		
	Step 1	Step 2	Total	Column $\alpha$	Column $\beta$	
<b>Homogeneous charge rich in A</b>						
Division of charge (kmol)	–	–	–	100	0	
Div. of vap. flow rate	–	–	–	0.9844		0.0156
Duration (h)	0.862	0.014	0.876		0.880	
Product A (kmol)	90.336	0.000	90.336	90.404		0.000
Product B (kmol)	0.000	9.544	9.544	0.000		9.596
Byproducts (kmol)	–	0.120	0.120		0.000	
Byprods. compn. (mol%A)	–	56.80	56.80		–	
<b>Homogeneous charge rich in B</b>						
Division of charge (kmol)	–	–	–	0		100
Div. of vap. flow rate	–	–	–	0.2538		0.7462
Duration (h)	0.101	0.034	0.135		0.136	
Product A (kmol)	0.502	0.000	0.502	0.505		0.000
Product B (kmol)	0.000	99.112	99.112	0.000		99.495
Byproducts	–	0.386	0.386		0.000	
Byprods. compn. (mol%A)	–	1.12	1.12		–	
<b>Heterogeneous charge</b>						
Division of charge (kmol)	–	–	–	51.8		48.2
Div. of vap. flow rate	–	–	–	0.9530		0.0470
Duration (h)	2.006	0.100	2.106		2.141	
Product A (kmol)	29.298	0.000	29.298	29.798		0.000
Product B (kmol)	0.000	69.823	69.823	0.000		70.202
Byproducts (kmol)	–	0.879	0.879		0.000	
Byprods. compn. (mol%A)	–	56.80	56.80		–	

is when the total amount of the charge is fed into reboiler  $\alpha$  ( $U_b^{\alpha}/U_{ch} = 1$ ).

The duration of the cycle is nearly equal for the two configurations (if we neglect the duration of pumping between the two steps of the BR).

In the case of DCS by the best policy the whole amount of *A* is already in the reboiler  $\alpha$  at the start and only *B* must be eliminated from it. The reason of the small value of  $v^{\beta}$  is that the *B*-rich phase flowing from the decanter into column  $\beta$  has already very high *B*-content ( $x_{AZ,B}^{Br} = 0.988$ ). Hence only a small amount of *A* must be removed in the form of azeotrope for the purification of *B*. The main advantage of the DCS is that there is no byproduct at all.

The ratio of the duration of the two steps of the BR ( $\tau^{(1)}/\tau^{(2)} = 61.57$ ) is close to that of vapour flow rates of the two columns of DCS ( $v^{\beta}/v^{\alpha} = 63.10$ ), which shows that energy demand of the production of both components is nearly the same for the two configurations.

#### 4.1.2. Homogeneous charge rich in B ( $\bar{x}_{ch} = [0.01, 0.99]$ )

a. Batch rectifier:

In Step 1 *B* is produced and in Step 2 *A* is produced (Table 1).

b. Double column system

We determined  $\tau$  and  $v^{\alpha}$  for different divisions of the charge. By the best operational policy (Table 1) the total amount of the charge is fed into reboiler  $\beta$ .

The duration of the cycle is nearly equal in the two cases.

Energy demand of the production of each component is again nearly the same for the two configurations ( $\tau^{(1)}/\tau^{(2)} = 2.971$ ,  $v^{\beta}/v^{\alpha} = 2.940$ ). The optimal division of the charge can be explained similarly as in the case of the previous charge composition.

#### 4.1.3. Heterogeneous charge

Before the distillation the charge of composition  $\bar{x}_{ch} = [0.3, 0.7]$  is separated by decantation into an *A*-rich ( $U_{Ar} = 51.8$  kmol) and a *B*-rich ( $U_{Br} = 48.2$  kmol) phases.

a. Batch rectifier:

In Step 1 the *A*-rich phase is distilled (by taking into consideration Inequality 1) and *A* is produced (as residue). In Step 2 the product is *B* (Table 1).

b. Double column system:

The preliminary decantation provides the division of the charge which determines the value of  $v^{\alpha}$ . Hence only one solution exists (Table 1).

**Table 2**  
Results for ternary mixture (simplified model).

	BR				DCS		
	Step 1	Step 2	Step 3	Total	Column $\alpha$	Column $\beta$	
Division of feed (kmol)	–	–	–	–	99.81		0.19
Div. of vap. flow rate	–	–	–	–	0.9650		0.0350
Duration (h)	8.055	0.010	0.261	8.326		8.494	
Product A (kmol)	64.001	0.000	0.000	64.001	67.576		0.000
Product B (kmol)	0.000	0.000	30.723	30.723	0.000		32.424
Byproducts (kmol)	–	0.160	5.224	5.384		0.000	
Byprods. compn.	–	TAZ	BAZ	–		–	

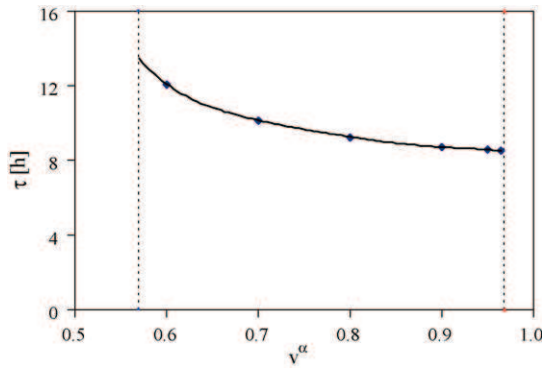

Fig. 8. Duration of the process for different divisions of the charge (simplified model).

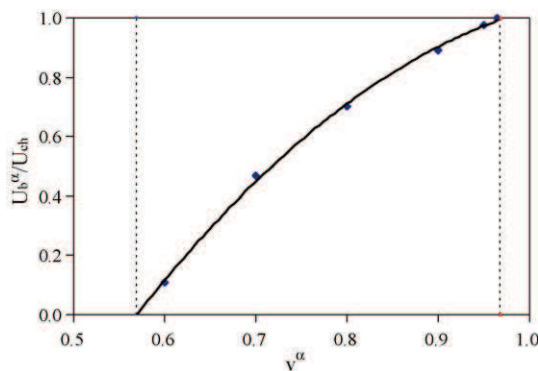

Fig. 9. Relative vapour flow rate of column  $\alpha$  for different divisions of the charge (simplified model).

The duration of the cycle is nearly equal in the two cases.

Energy demand of the production of each component is nearly the same for the two configurations ( $\tau^{(1)}/\tau^{(2)}=20.06$ ,  $v^{\beta}/v^{\alpha}=20.28$ ) like in the previous cases.

#### 4.2. Distillation of a ternary mixture (isopropanol (A)–water (B) + benzene (E))

Binary azeotropic charge ( $\vec{x}_{ch} = \vec{x}_{BAZ} = [0.674, 0.326, 0]$ ) is separated by the application of an entrainer. The composition of the ternary IPA–water–benzene heteroazeotrope and those of its E-rich and B-rich phases are, respectively:

$$\vec{x}_{TAZ} = [0.238, 0.239, 0.523], \quad \vec{x}_{TAZ}^{Er} = [0.277, 0.048, 0.675],$$

$$\vec{x}_{TAZ}^{Br} = [0.103, 0.894, 0.003]$$

a. Batch rectifier:

Calculation results are shown in Table 2.

b. Double column system:

We determine  $\tau$  and  $U_b^{\alpha}/U_{ch}$  for different relative vapour flow rates of column  $\alpha$  (Figs. 8–9). Calculation results for the best operational policy are shown in Table 2.

The duration of cycle is nearly equal in the two cases. The amount of the final byproduct is more than 5% of the charge for the BR, whilst there is no byproduct at all by the DCS.

The energy demand of the production of each component is nearly the same for the two configurations.

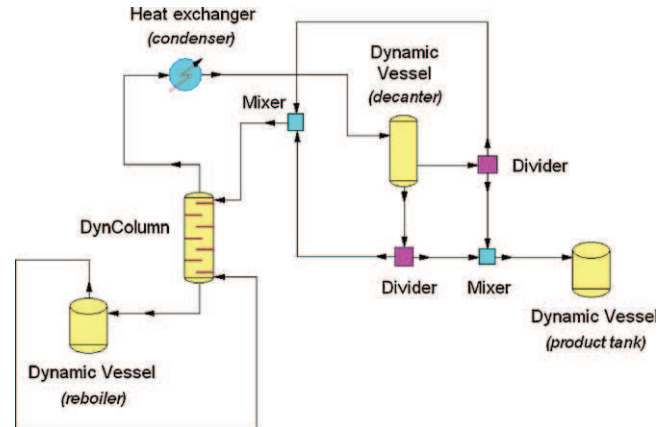

Fig. 10. ChemCad model of the batch rectifier equipped with a decanter.

The ratio of the duration of producing A and that of B:  $\frac{\tau^{(1)}}{\tau^{(2)}+\tau^{(3)}} = 29.72$ .

The ratio of vapour flow rates of the two columns for the DCS:  $v^{\beta}/v^{\alpha} = 27.57$ .

### 5. Simulation method

When making detailed simulation calculations we already take into consideration (contrary to the feasibility studies):

- the variation of the composition and the flow rate of the streams with time,
- that the separation is not maximal,
- the liquid holdup of the trays and that of the decanter,
- the entrainer loss (ternary mixture).

The following simplifying assumptions are applied:

- theoretical trays,
- constant volumetric liquid holdup on the trays and in the decanter,
- negligible vapour holdup,
- negligible duration of pumping between the two steps (BR).

The model equations to be solved are well-known (e.g. Mujtaba (2004)):

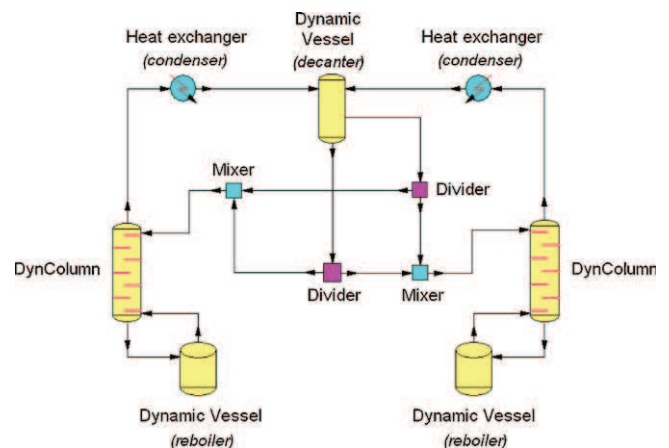

Fig. 11. ChemCad model of the new double column system.

- Non-linear differential equations (material balances, heat balances).
- Algebraic equations (VLE, LLE relationships, summation equations, holdup and physical property models).

For describing phase equilibria NRTL (for the binary mixture) and UNIQUAC (for the ternary mixture) models are applied. For the solution of the above equations the dynamic simulator of ChemCad 5.6 (program CC-DCOLUMN) is applied. Column sections are modelled by the module DYNAMIC COLUMN, reboilers and the (vertical cylindrical flat bottom) decanter by the DYNAMIC VESSEL, respectively (Figs. 10–11). Besides these units the flow-sheet still contains HEAT EXCHANGERS (condensers), MIXERS and DIVIDERS (stream splitters). The ChemCad models built-up make possible to lead any liquid phases into any columns, hence all configurations are suitable for the production of all components without the change of the pipe network shown. Furthermore they are suitable also for two liquid-phase refluxes which are not applied in this work.

## 6. Simulation results

We investigate the separation of the same mixtures with the same compositions as in the case of feasibility studies. The

sequence of the production of the components by the BR is also identical to that applied in the course of feasibility studies.

In each case the total number of theoretical stages ( $N$ ) (without the condenser, decanter and reboiler) is 10 for both configurations. The separation is performed at atmospheric pressure. Both reflux and distillate (BR) are homogeneous. In the decanter ( $D=0.5$  m) the volume of liquid phases are prescribed constant (after the start-up). The ratio of the volumes of the two phases is equal to that of the binary/ternary heteroazeotrope. The holdup of the plates is taken  $\sim 1\%$  of the initial liquid volume in the reboiler of the given column. In each case the amount of charge ( $U_{ch}$ ) is 100 kmol and the prescribed purity of both products is 99.5 mol%. The calculations are started with dry plates and decanter.

For both configurations there is an optimal amount of entrainer for which the (total) duration of the production cycle is minimal. For the DCS the duration of the distillation in the two columns can be also influenced by the division of the total number of plates ( $N^\alpha/N$ ), total heat duty ( $Q^\alpha/Q$ ), and the amount of charge ( $U_b^\alpha/U_{ch}$ ). In this paper for each configuration we publish the results only for the optimal case with minimal duration.

**Table 3**  
Optimal parameters and results for the binary mixture of different compositions (detailed model;  $N^\alpha = N^\beta = 5$ ).

	BR			DCS	
	Step 1	Step 2	Total	Column $\alpha$	Column $\beta$
<b>Homogeneous charge rich in A</b>					
Division of feed (kmol)	–	–	–	99.1	0.9
Heat duty (MJ/min)	10	10	–	9.4	0.6
Plate holdup (dm/plate)	80	2	–	80	10
Duration (h)	3.85	0.04	3.89		4.23
Product A (kmol)	81.336	0.000	81.336	85.521	0.000
Product B (kmol)	0.000	6.776	6.776	0.000	4.419
Distillate (kmol)	7.282	0.000	0.000		0.000
Distillate compn. (mol%A)	1.13	–	–		–
Column holdup (kmol)	8.387	0.017	8.404		7.065
Col. hup. compn. (mol%A)	98.02	–	–		58.31
Decanter holdup (kmol)	2.995	0.489	3.484		2.995
Dec. hup. compn. (mol%A)	25.62	20.20	–		25.62
Byproducts (kmol)	11.382	0.506	11.888		10.060
<b>Homogeneous charge rich in B</b>					
Division of feed (kmol)	–	–	–	1.5	98.5
Heat duty (MJ/min)	16	–	–	0.86	15.14
Plate holdup (dm/plate)	20	–	–	10	80
Duration (h)	0.15	–	0.15		0.18
Product A (kmol)	0.000	–	0.000	0.000	0.000
Product B (kmol)	97.083	–	–	4.043	92.482
Distillate (kmol)	0.000	–	–		0.000
Distillate compn. (mol%A)	–	–	–		–
Column holdup (kmol)	0.375	–	0.375		0.942
Col. hup. compn. (mol%A)	–	–	–		3.45
Decanter holdup (kmol)	2.542	–	2.542		2.533
Dec. hup. compn. (mol%A)	20.06	–	–		19.94
Byproducts (kmol)	2.917	–	2.917		3.475
<b>Heterogeneous charge</b>					
Division of feed (kmol)	–	–	–	51.8	48.2
Heat duty (MJ/min)	12	12	–	11.47	0.53
Plate holdup (dm/plate)	30	10	–	30	10
Duration (h)	3.15 (0.13)	0.18 (3.20)	3.33 (3.33)		3.50
Product A (kmol)	24.948 (0.000)	0.000 (25.374)	24.948 (25.374)	26.948	0.000
Product B (kmol)	0.000 (46.210)	65.851 (0.000)	65.851 (46.210)	0.000	65.449
Distillate (kmol)	20.360 (0.000)	0.000 (20.688)	0.000 (20.688)		0.000
Dist. compn. (mol%A)	1.13 (–)	–((1.13))	–((1.13))		–
Column holdup (kmol)	3.497 (0.247)	0.246 (2.743)	3.743 (2.990)		4.608
Col. hup. compn. (mol%A)	– (–)	– (–)	– (–)		45.23
Decanter holdup (kmol)	2.995 (1.743)	2.463 (2.995)	5.458 (4.738)		2.995
Dec. hup compn. (mol%A)	25.62 (20.87)	20.62 (25.62)	–		25.62
Byproducts (kmol)	6.492 (1.990)	2.709 (26.426)	9.201 (28.416)		7.603

**Table 4**  
Optimal parameters and results for the ternary mixture (detailed model).

	BR		DCS-1		DCS-2		DCS-3		
	Step 1	Step 2	Total	Column $\alpha$	Column $\beta$	Column $\alpha$	Column $\beta$	Column $\alpha$	Column $\beta$
	Division of feed (kmol)	-	-	-	77.0	23.0	77.0	23.0	77.0
Heat duty (MJ/min)	12	12	-	11.03	0.97	11.10	0.90	11.05	0.95
Number of plates	10	10	-	8	2	10	10	10	10
Plate holdup (dm <sup>3</sup> /plate)	60	10	-	47	13	47	13	31	9
Entrainer (kmol)	4.2	0.0	-	3.9	0.0	3.9	0.0	3.9	0.0
Duration (h)	35.60	0.85	36.45	58.700	34.0	57.517	35.0	59.449	33.7
Product A (kmol)	55.972	0.000	55.972	0.000	0.000	0.000	0.000	0.000	0.000
Product B (kmol)	0.000	23.586	23.586	0.000	29.320	0.000	29.320	0.000	26.062
Distillate (kmol)	36.434	10.230	10.230	0.000	0.000	0.000	0.000	0.000	0.000
Distillate compn. (mol%A)	11.94	40.89	-	-	-	-	-	-	-
Distillate compn. (mol%B)	87.71	56.25	-	-	-	-	-	-	-
Column holdup (kmol)	10.187	2.378	12.565	14.260	14.260	20.773	20.773	16.775	16.775
Col. holdup compn. (mol%A)	67.18	-	-	58.42	58.42	45.78	45.78	45.23	45.23
Col. holdup compn. (mol%B)	0.83	-	-	19.26	19.26	38.87	38.87	35.84	35.84
Decanter holdup (kmol)	1.607	0.240	1.847	1.620	1.620	1.620	1.620	1.614	1.614
Dec. holdup compn. (mol%A)	31.99	11.23	-	33.69	33.69	33.68	33.68	32.96	32.96
Dec. holdup compn. (mol%B)	21.90	88.77	-	22.38	22.38	22.38	22.38	22.16	22.16
Byproducts (kmol)	11.794	12.848	24.642	15.880	15.880	22.393	22.393	18.389	18.389

### 6.1. Separation of a binary heteroazeotropic mixture

We investigate the separation of the same mixture for the same charge compositions as in the feasibility studies.

#### 6.1.1. Homogeneous charge rich in A

The total heat duty ( $Q$ ) is 10 MJ/min in each case. The charge volume is 8.360 m<sup>3</sup>. First the BR then the DCS are studied, finally the two configurations are compared.

##### a. Batch rectifier:

In Step 1 A is produced as bottom residue (Table 3). (When in Step 1 we tried to produce B we did not reach the prescribed purity at all.) Step 2 is very short since the amount of distillate (B-rich phase) in Step 1 is very low (7.3 mol% of the charge) and the A-content of this distillate, which must be removed in Step 2, is also very low (1.2 mol%).

##### b. Double column system (Table 3):

In column  $\alpha$  of the DCS the heat duty and the amount of liquid to be distilled is much higher than in the other column due to the high content of A of the charge and because the B-rich phase purified in column  $\beta$  hardly contains A.

Comparing the two different configurations we can state that

- The duration of the process is shorter by 8% for the BR.
- However for the BR the amount of byproducts is higher by 15%.
- The recovery of A is higher for the DCS (94.5% instead of 89.9%).

#### 6.1.2. Homogeneous charge rich in B

The total heat duty:  $Q = 16$  MJ/min in each case. The charge volume is 1.874 m<sup>3</sup>.

##### a. Batch rectifier:

In the BR B is produced in Step 1 as bottom residue (Table 3). (If in Step 1 we try to produce A the prescribed purity cannot be reached at all.) Since in the charge the amount of A is very low the bottom residue reaches the prescribed purity of B before filling up the decanter. (The majority of A appears in the column holdup.) Since the amount of distillate in Step 1 is zero there is no need for Step 2.

##### b. Double column system (Table 3):

In the DCS (similarly to the BR) A of prescribed purity cannot be produced at all, A accumulates in the holdup. In column  $\alpha$  the heat duty and the amount of liquid to be distilled is much lower than in the other column due to the low content of A in the charge.

Comparing the two different configurations we can state that

- The duration of the process is almost the same for the two different configurations (BR: 0.15 h, DCS: 0.18 h).
- The recovery of B is similar for the BR (97.57%) and DCS (97.01%).

#### 6.1.3. Heterogeneous charge

The total heat duty is  $Q = 12$  MJ/min in each case. The volume of the charge is 3.988 m<sup>3</sup>.

Before the distillation the charge is separated into two liquid phases:

$$A\text{-rich} : U_b^\alpha = 51.8 \text{ kmol}, \quad x_A = 0.568; \quad B\text{-rich} :$$

$$U_b^\beta = 48.2 \text{ kmol}, \quad x_A = 0.012$$

##### a. Batch rectifier:

In the BR both components could be produced in Step 1. If *A* is produced first we get better results (Table 3, where the results of the other sequence are given in brackets). Step 2 is very short since the amount of distillate (*B*-rich phase) in Step 1 is low (20.4 mol% of the charge) and the *A*-content of this distillate, which must be removed in Step 2, is very low (1.2 mol%).

b. Double column system (Table 3):

In the DCS the heat duty of column  $\alpha$  (95.6%) is much higher than in the other column due to the high content of *B* (43.2 mol%) whilst the *B*-rich phase purified in column  $\beta$  hardly contains *A* (1.2 mol%). In this case the charge must be divided almost half-and-half between the two reboilers.

Comparing the two different configurations we can conclude that

- The duration of the process is slightly shorter (by 5%) for the BR.
- However for the BR the amount of byproducts is higher (9.2% vs. 7.6%).
- The recovery of *A* is higher for the DCS (89.4% instead of 82.7%).

6.2. Separation of a binary homoazeotrope by using an entrainer

The total heat duty is  $Q = 12 \text{ MJ/min}$  in each case. The volume of the charge is  $5.690 \text{ m}^3$ .

The prescribed levels of the decanter: *B*-rich phase: 0.0384 m, *E*-rich phase: 0.6 m.

a. Batch rectifier:

For the BR the optimal amount of *E* by which the duration of Step 1 (determining primarily the duration of the production cycle) is minimal: 4.2 kmol ( $0.371 \text{ m}^3$ ). In Step 1 *A* is produced (Table 4). The duration of this step is much longer than that of Step 2. Though the amount of distillate (*B*-rich phase) in Step 1 is not too low (36.4 mol% of the charge) but the *E*-content of this distillate, which must be removed (together with *A*) in Step 2, is very low (0.35 mol%). In Step 2 *B* is purified not only from *E* but

also from *A* in the form of binary azeotrope *A*-*B* whose *A*-content is relatively high.

b. Double column system:

For the ternary mixture three variations of the DCS are studied.

- DCS-1:  $N^\alpha + N^\beta = 10$ , volumetric liquid plate holdup in column  $\alpha$  (and  $\beta$ ): 1% of the volume of the initial charge of reboiler  $\alpha$  (and  $\beta$ ).
- DCS-2:  $N^\alpha = N^\beta = 10$ , volumetric liquid plate holdup in column  $\alpha/\beta$ : 1% of the volume of the initial charge of reboiler  $\alpha$  (or  $\beta$ ).
- DCS-3:  $N^\alpha = N^\beta = 10$ , the overall liquid plate holdup is equal to that of the DCS-1, the ratio of the plate holdups in the two columns are equal to the ratio of the volumes of the initial charges in the two reboilers.

For the DCS-1 the optimal division of the total number of plates is rather unequal. (In all binary cases studied the influence of the division of the plates is slight on the results.) For all the three variations the optimal amount of *E*: 3.9 kmol. The whole amount of *E* is filled in reboiler  $\alpha$ . The division of the heat duty is very similar in each case. The heat duty of reboiler  $\alpha$  (92% of  $Q$ ) is much higher than that of the other reboiler. The *A*-content of the top vapour of column  $\beta$  is relatively high. In these cases 77% of the charge must be filled in the reboiler  $\alpha$ . Among the three variations the least advantageous is the DCS-2 since its total holdup is greater than that of the other ones. The performance of DCS-1 and DCS-3 is nearly the same. Their durations are almost identical and the recovery of *A* is nearly equal in the two cases. In DCS-1 somewhat more *B* and less byproducts are produced.

Comparing the two different configurations we can conclude that

- The duration of the process is slightly shorter for the DCS.
- The recovery of both components is somewhat higher for the DCS.

In Fig. 12 the evolution of liquid compositions in the reboilers is shown for both configurations. In the BR the two produced components are purified in the reboiler sequentially, in two operation steps. However, in the DCS these two components can be simultaneously produced in one step.

7. Conclusion

We suggested a new double column system (DCS) for heterogeneous batch distillation. The system is operated in closed mode without continuous product withdrawal. This configuration was investigated by feasibility studies based on a simplified model (assumption of maximal separation, neglect of holdup) and by dynamic simulation (based on a detailed model) by using a professional simulator (CC-DCOLUMN). The performance of this new DCS was compared with the traditional batch rectifier (BR). For the new configuration we determined the minimal operational time. The calculations and the simulations were performed for the mixtures *n*-butanol–water and isopropanol–water + benzene (entrainer). The new configuration proved to be feasible and competitive with the conventional BR. For the binary mixture DCS gave similar and for the ternary one better performance than the BR. Its main benefit is that produces fewer byproducts to be separated later. Because of its performance and simple operation (distillation is performed in only one step) DCS appears to have high potential and deserves further investigations (further mixtures, operational issues, closed loop control, etc.).

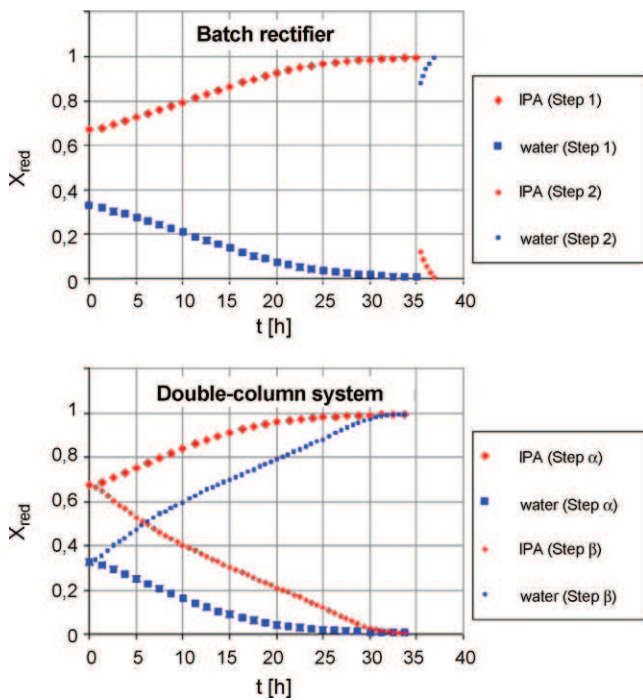

Fig. 12. The evolution of liquid compositions in the reboiler(s) (ternary mixture).

## References

- Cui, X. B., Yang, Z. C., Zhai, Y. R., & Pan, Y. J. (2002). Batch extractive distillation in a column with a middle vessel. *Chinese Journal of Chemical Engineering*, 10(5), 529–534.
- Duessel, R., & Stichlmair, J. (1995). Separation of azeotropic mixtures by batch distillation using an entrainer. *Computers & Chemical Engineering*, 19, 113–118.
- Koehler, J., Haverkamp, H., & Schadler, N. (1995). Zur Diskontinuierlichen Rektifikation Azeotroper Gemische mit Hilfsstoffeinsatz. *Chemie Ingenieur Technik*, 67(8), 967.
- Kotai, B., Lang, P., & Modla, G. (2007). Batch extractive distillation as a hybrid process: separation of minimum boiling azeotropes. *Chemical Engineering Science*, 62, 6816–6826.
- Lang, P., Kovacs, Gy., Kotai, B., Gaal-Szilagy, J., & Modla, G. (2006). *Industrial application of a new batch extractive distillation operational policy. IChemE symposium series* (pp. 830–839, No. 152).
- Lang, P., & Modla, G. (2006). Generalised method for the determination of heterogeneous batch distillation regions. *Chemical Engineering Science*, 61, 4262–4270.
- Lang, P., Yatim, H., Moszkowicz, P., & Otterbein, M. (1994). Batch extractive distillation under constant reflux ratio. *Computers & Chemical Engineering*, 18, 1057–1069.
- Lelkes, Z., Lang, P., Benadda, B., & Moszkowicz, P. (1998). Feasibility of extractive distillation in a batch rectifier. *AIChE Journal*, 44, 810–822.
- Low, K. H., & Sorensen, E. (2002). Optimal operation of extractive distillation in different batch configurations. *AIChE Journal*, 48(5), 1034–1050.
- Modla, G., & Lang, P. (2008). Feasibility of new pressure swing batch distillation methods. *Chemical Engineering Science*, 63(11), 2856–2874.
- Modla, G., Lang, P., Kotai, B., & Molnar, K. (2003). Batch heteroazeotropic rectification of a low relative volatility mixture under continuous entrainer feeding. *AIChE Journal*, 49(10), 2533.
- Modla, G., Lang, P., & Molnar, K. (2001). Batch heteroazeotropic rectification of a low relative volatility mixture under continuous entrainer feeding: Feasibility studies. In *Proceedings of the 6th world congress of chemical engineering* Melbourne, Australia, (10 pages on CD).
- Mujtaba, I. M. (2004). Batch distillation: Design and operation (pp. 68–71). Imperial College Press, ISBN 1-86094-437-X.
- Pham, H. N., & Doherty, M. F. (1990). Design and synthesis of heterogeneous azeotropic distillations. II. Residue curve maps. *Chemical Engineering Science*, 45(7), 1837.
- Phimister, J. R., & Seider, W. D. (2000). Semicontinuous, pressure swing distillation. *Industrial & Engineering Chemistry Research*, 39, 122–130.
- Pommier, S., Massebeuf, S., Kotai, B., Lang, P., Baudouin, O., & Gerbaud, V. (2008). Heterogeneous batch distillation processes: Real system optimisation. *Chemical Engineering and Processing*, 47(3), 408–419.
- Repke, J. U., Klein, A., Bogle, D., & Wozny, G. (2007). Pressure swing batch distillation for homogenous azeotropic separation. *Chemical Engineering Research & Design*, 85(4), 492–501.
- Rodriguez-Donis, I., Equijarosa, J. A., Gerbaud, V., & Joulia, X. (2003). Heterogeneous batch-extractive distillation of minimum boiling azeotropic mixtures. *AIChE Journal*, 49(12), 3074.
- Rodriguez-Donis, I., Gerbaud, V., & Joulia, X. (2002). Feasibility of heterogeneous batch distillation processes. *AIChE Journal*, 48(6), 1168.
- Safrit, B. T., Westerberg, A. W., Diwekar, U., & Wahnschafft, O. M. (1995). Extending continuous conventional and extractive distillation feasibility insights to batch distillation. *Industrial & Engineering Chemistry Research*, 34, 436.
- Skouras, S., Kiva, V., & Skogestad, S. (2005). Feasible separations and entrainer selection rules for heteroazeotropic batch distillation. *Chemical Engineering Science*, 60, 2895.
- Skouras, S., Skogestad, S., & Kiva, V. (2005). Analysis and control of heteroazeotropic batch distillation. *AIChE Journal*, 51(4), 1144–1157.
- Steger, C., Rev, E., Horvath, L., Fonyo, Z., Meyer, M., & Lelkes, Z. (2006). New extractive configuration separating azeotropic mixtures in semi-batch way. *Separation and Purification Technology*, 52(2), 343–356.
- Warter, M., Demicoli, D., & Stichlmair, J. (2004). Operation of a batch distillation column with a middle vessel: Experimental results for the separation of zeotropic and azeotropic mixtures. *Chemical Engineering and Processing*, 43, 263–272.
- Warter, M., & Stichlmair, J. (1999). Batchwise extractive distillation in a column with a middle vessel. *Computers & Chemical Engineering*, 23, 915–918.