



HAL
open science

Speaker Attentive Speech Emotion Recognition

Clément Le Moine, Nicolas Obin, Axel Roebel

► **To cite this version:**

Clément Le Moine, Nicolas Obin, Axel Roebel. Speaker Attentive Speech Emotion Recognition. Interspeech 2021, Aug 2021, Brno, Czech Republic. pp.2866-2870, 10.21437/interspeech.2021-573 . hal-03554368

HAL Id: hal-03554368

<https://hal.science/hal-03554368>

Submitted on 3 Feb 2022

HAL is a multi-disciplinary open access archive for the deposit and dissemination of scientific research documents, whether they are published or not. The documents may come from teaching and research institutions in France or abroad, or from public or private research centers.

L'archive ouverte pluridisciplinaire **HAL**, est destinée au dépôt et à la diffusion de documents scientifiques de niveau recherche, publiés ou non, émanant des établissements d'enseignement et de recherche français ou étrangers, des laboratoires publics ou privés.

See discussions, stats, and author profiles for this publication at: <https://www.researchgate.net/publication/354221467>

Speaker Attentive Speech Emotion Recognition

Conference Paper · August 2021

DOI: 10.21437/Interspeech.2021-573

CITATIONS

0

READS

31

3 authors:



Clément Le Moine

Institut de Recherche et Coordination Acoustique/Musique

6 PUBLICATIONS 13 CITATIONS

[SEE PROFILE](#)



Nicolas Obin

Institut de Recherche et Coordination Acoustique/Musique

93 PUBLICATIONS 597 CITATIONS

[SEE PROFILE](#)



Axel Roebel

Institut de Recherche et Coordination Acoustique/Musique

178 PUBLICATIONS 1,752 CITATIONS

[SEE PROFILE](#)

Some of the authors of this publication are also working on these related projects:



TheVoice: voice design for the creative industries [View project](#)



Sample Orchestrator 2 [View project](#)



Speaker Attentive Speech Emotion Recognition

Clément Le Moine, Nicolas Obin, Axel Roebel

STMS Lab
IRCAM, CNRS, Sorbonne Université,
Paris, France

Abstract

Speech Emotion Recognition (SER) task has known significant improvements over the last years with the advent of Deep Neural Networks (DNNs). However, even the most successful methods are still rather failing when adaptation to specific speakers and scenarios is needed, inevitably leading to poorer performances when compared to humans. In this paper, we present novel work based on the idea of teaching the emotion recognition network about speaker identity. Our system is a combination of two ACRNN classifiers respectively dedicated to speaker and emotion recognition. The first informs the latter through a Self Speaker Attention (SSA) mechanism that is shown to considerably help to focus on emotional information of the speech signal. Speaker-dependant experiments on social attitudes database Att-HACK and IEMOCAP corpus demonstrate the effectiveness of the proposed method and achieve the state-of-the-art performance in terms of unweighted average recall.

Index Terms: speaker attentive emotion recognition, convolutional recurrent neural networks, attention

1. Introduction

1.1. Context

Speech is one of the most important medium for human communication, not only conveying linguistic information but also rich and subtle para-linguistic information. In particular the affective prosody of speech conveys the emotions which play an important role in the perception of an utterance meaning. Therefore, speech emotion recognition (SER), which aims to recognize the actual emotional state of a speaker from the utterance he produced, has raised a great interest among researchers.

As pointed out by Scherer in [1], there is an undeniable contradiction between the apparent ease with which listeners judge emotions from speech and the intricacy of finding discriminative features in speech signal for emotion recognition. This contradiction, in part, lies in the role that individual difference variables play in the production of emotional speech [2]. In particular, the acoustic characteristics of the speaker voice as well as its speaking style, for a significant part, determine its way of expressing the emotions.

1.2. Related works

Formerly addressed using statistical methods and traditional learning techniques such as Hidden Markov Models (HMMs), Gaussian Mixture Models (GMMs) and Support Vector Machines (SVMs), the SER task has known significant improvements over the past years with the advent of deep neural networks (DNNs). Indeed such deep networks have shown excellent abilities to model more complex patterns within speech ut-

terances by extracting high-level features from speech signal for better recognition of the emotional state of the speakers.

Mao et al. [3] firstly introduced Convolutional Neural Networks (CNNs) for the SER task and obtained remarkable results on various datasets by learning affective-salient features. Recurrent neural networks (RNNs) has also been introduced for SER purpose with a deep Bidirectional Long Short-Term Memory (BLSTM) network proposed by Lee et al. [4]. Several papers have then presented CNNs in combination with LSTM cells to improve speech emotion recognition, based on log Mel filterbanks (logMel) [5] or raw signal in an end-to-end manner [6].

Recently, attention mechanisms have raised great interest in the SER research area for their ability to focus on specific parts of an utterance that characterize emotions. Mirasmadi et al. [7] approached the problem with a recurrent neural network and a local attention model used to learn weighted time-pooling strategies. Neumann et al. [8] used an attentive CNN (ACNN) and showed the importance of the model architecture choice against the features choice. Ramet et al. [9] presented a review of attention models on top of BLSTMs and proposed a new attention computed from the outputs of an added BLSTM layer. Chen et al. [10] proposed a 3-D Attention-based Convolutional Recurrent Neural Networks (ACRNN) for SER with 3-D log-Mel spectrograms (static, deltas and delta-deltas) as input features. They showed 3-D convolution can better capture more effective information for SER compared with 2-D convolution. Recently, Meng et al. [11] outperformed this method by using dilated convolutions in place of a pooling layer and skip connection.

Attempts to inform emotion classification networks with extra-information involved in the description of emotions were proposed in the past years. Based on previous works [12, 13, 14], Li et al. [15] proposed a multitask learning framework that involves gender classification as an auxiliary task to provide emotion-relevant information leading to significant improvements in SER. Analogously, speaker identity has been used to inform emotion classification networks. The problem was approached by Sidorov et al. [16] with speaker dependent models for emotion recognition. Recently, a method for speaker aware SER was introduced by Assunção et al. [17], a CNN model VGGVox [18] is trained for speaker identification but is instead used as a front-end for extracting robust features from emotional speech. These first attempts have shown that teaching SER systems with additional signal-based information can greatly improve performances.

1.3. Contributions of the paper

In this paper, we assume that individuals may use different means to express emotions, and then that SER should be conditioned on the speaker identity information. Following this hypothesis, we propose a novel method based on previous work

[10]. The major contributions of this paper are summarized as:

1. Conditioning emotion classification to speaker identity by using a key-query-value attention we called Self Speaker Attention (SSA) that allows to compute both self and cross-attribute (relation between speaker identity and emotions) attention scores to focus on emotion relevant parts of an utterance.
2. Proposing a novel regularization by constraining the weights of the last fully connected layer of the network so as to avoid class collapse.
3. Achieving an absolute increase of UAR by 2.26 % for IEMOCAP compared with the best existing result in speaker-dependant experiment.

2. Proposed Methodology

In this section, we introduce our SSA-CRNN proposal for SER and a regularization answering class collapse issue. First, the computation of log-Mel spectrograms is described 2.1, then the basic ACRNN architecture from which our proposal is derived is presented in 2.2. Finally our contributions are detailed : the SSA-CRNN architecture is presented in 2.3 and our novel regularization in 2.4.

2.1. 3-D Log-Mel spectrograms

3-D Log-Mel spectrograms (with delta and delat-deltas), already used as input features for various tasks, were introduced for the SER task by Chen et al. [10] as input of their ACRNN model and later used in [11]. In this paper, the Log-Mel spectrograms are computed as presented in [11]. The 3-D Log-Mel spectrogram consists of a three channel input. The first channel is the static of the Log-Mel spectrogram from 40 filterbanks, the second and third channels are respectively deltas and delta-deltas which can be considered as approximations of the first and second derivatives of the first channel. Once obtained, each 3-D input sample is normalized to have zero mean and unit variance for a given speaker.

2.2. Architecture of (self) Attentive Convolutional Recurrent Neural Net (ACRNN)

Given 3-D log-Mel spectrograms, CRNN is used in [10] to extract high-level features for speech emotion recognition. The same architecture is used in our proposal to extract high-level features in both cases of SER and speaker recognition (SR).

2.2.1. Architecture of CRNN

The CRNN architecture consists of several 3-D convolution layers, one 3-D maxpooling layers, one linear layer and one LSTM layer. Specifically, the first convolutional layer has 128 feature maps, while the remaining convolutional layers have 256 feature maps, and the filter size of each convolutional layer is 5×3 , where 5 corresponds to the time axis, and 3 corresponds to the frequency axis. A max-pooling is performed after the first convolutional layer with pooling size is 2×2 . The 3D features are reshaped to 2D, keeping time dimension unchanged and passed to a linear layer for dimension reduction before reaching the recurrent layer. As precised in [10], a linear layer of 768 output units is shown to be appropriate. These features are then processed through a bi-directional recurrent neural network with long short term memory cells (BLSTM) [19], with 128 cells in each direction, for temporal summarization, which allows to get d-dimensional high-level feature representations ($d = 256$).

2.2.2. Self Attention (SA) mechsanim

With a sequence of high-level representations, an attention layer is employed to focus on relevant features and produce discriminative utterance-level representations for classification, since not all frame-level CRNN features contribute equally to the representation of the attributes to recognize, in both cases of SER and speaker recognition.

Specifically, with the classifier's BLSTM output $\mathbf{h}_{att} = [h_{att}^1, \dots, h_{att}^T] \in \mathbb{R}^{T \times d}$, a temporal vector $\alpha_{att} \in \mathbb{R}^T$, representing the contribution per frame to the attribute to recognize, is computed depending on learnt weights vector $W_{att} \in \mathbb{R}^d$. Then α_{att} is used to obtain an utterance-level representation by computing the weighted sum of temporal BLSTM internal states c_{att} often called context vector.

$$\alpha_{att} = \frac{\exp(\mathbf{h}_{att} W_{att})}{\sum_{t=1}^T \exp(W_{att} h_{att}^t)} \in \mathbb{R}^T \quad (1)$$

$$c_{att} = \sum_{t=1}^T \alpha_{att}^t h_{att}^t \quad (2)$$

The attention layer is followed by a fully connected layer that determines the embedding size.

2.3. Architecture of the proposed Self Speaker Attentive Convolutional Neural Net (SSA-CRNN)

Our system shown in Figure 1 is formed by two classifiers C_{sp} and C_{em} . The first is an ACRNN and trained for SR. The second has the same architecture apart from its Self Speaker Attention (SSA) layer and is trained (along with C_{sp}) for SER, conditionally to the speakers embedding produced by C_{sp} and through the SSA mechanism described further. This conditioning of SER to speaker identity is expected to help C_{em} to better capture speakers individual strategies for emotion expression leading to better global SER performances.

2.3.1. Self Speaker Attention (SSA) mechanism

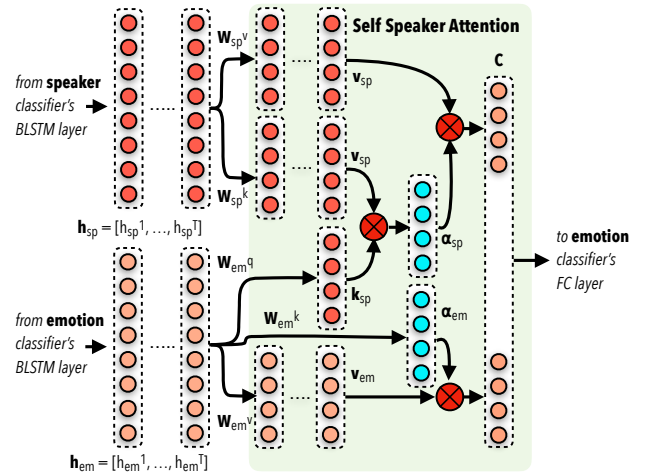

Figure 2: Self Speaker Attention (SSA) Mechanism

Inspired by [19] that used multi-modal attention technique for SER, we employed the query-key-value representation to compute the attention from two inputs : \mathbf{h}_{em} and \mathbf{h}_{sp} respectively related to "self" and "speaker" aspects. As depicted in Figure

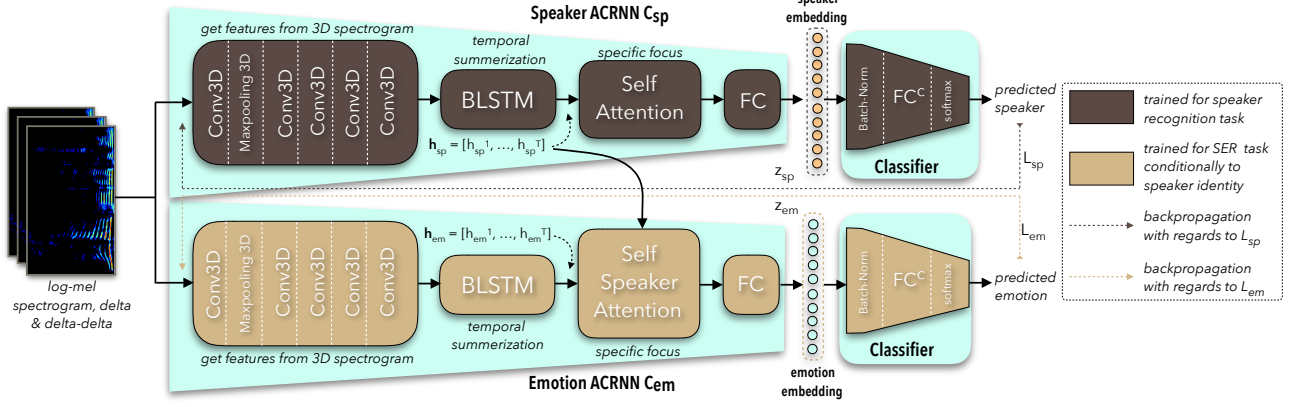

Figure 1: *Self Speaker Attentive Convolutional Recurrent Neural Network (SSA-CRNN)* for speaker attentive speech emotion recognition composed with two classifiers C_{sp} (up) and C_{em} (bottom) connected through the *Self Speaker Attention (SSA)* mechanism.

2, we first compute the query of speech emotion q_{em} through learnable weights $W_{em}^q \in \mathbb{R}^T$.

$$q_{em} = \mathbf{h}_{em}^T W_{em}^q \quad (3)$$

The keys K and values V are computed using learnable weights $W_{em}^k \in \mathbb{R}^d$ and $W_{sp}^k, W_{em}^v, W_{sp}^v \in \mathbb{R}^{d \times d}$ as follows.

$$\alpha_{em} = \mathbf{h}_{em} W_{em}^q \quad (4)$$

$$\alpha_{sp} = \frac{q_{em}^T K^T}{\sqrt{T}} \quad (5)$$

The self attention and cross-attribute scores α_{em} and α_{sp} are computed. Then both are concatenated, passed to a softmax activation layer and finally multiplied with values $V = [\mathbf{h}_{em} W_{em}^v, \mathbf{h}_{sp} W_{sp}^v]$ to obtain $c \in \mathbb{R}^{2d}$ which represents the interaction of speaker identity and speech emotion answering to speech emotion query.

$$\alpha = \text{softmax}([\alpha_{em}, \alpha_{sp}]) \quad (6)$$

$$c = \sum_{t=1}^{2T} \alpha^t V^t \quad (7)$$

2.4. Weights regularization

During preliminary experiments with ACRNN on the large database Att-HACK presented in 3.1, we faced a class collapse issue : the model tended to focus on one or two of the four classes at the expense of the others. That led to have one or several categories very badly recognized. In order to avoid this pitfall, we elaborated a training regularization by constraining the weights $W \in \mathbb{R}^{n_{em} \times 4}$ of the last fully connected layer FC^c , also called classification layer, just before the *softmax* activation. Denoting $W^c \in \mathbb{R}^{n_{em}}$ the c -ieth column of W , N the batch size, then for all input batch $\mathbf{x} = [x_1, \dots, x_N]$, FC^c is being fed with, the constraint ensuring all classes are equi-outputted can be expressed as follows.

$$\|W^c\|_1 = N \left(4 \left\| \sum_{i=1}^N x_i \right\|_1 \right)^{-1} \quad (8)$$

3. Experiments

3.1. Datasets

To evaluate the performance of our proposed model, we perform speaker-dependent SER experiments on the speech database for speech social attitudes Att-HACK [20] and the Interactive Emotional Dyadic Motion Capture database (IEMOCAP) [21]. Att-HACK comprises 20 speakers interpreting 100 utterances in 4 social attitudes : *friendly*, *distant*, *dominant* and *seductive*. With 3 to 5 repetitions each per attitude for a total of around 30 hours of speech, the database offers a wide variety of prosodic strategies in the expression of attitudes. IEMOCAP consists of 5 sessions and each session is displayed by a pair of speakers (female and male) in scripted and improvised scenarios. For this experiment, only improvised data and 4 emotions, *happy*, *angry*, *sad* and *neutral* were considered.

3.2. Experiment Setup

As for the feature extraction, we split the speech signal into equal-length segments of 3 seconds for better parallel acceleration and adopt zero-padding for utterances not reaching the 3 seconds.

- **ACRNN** : Re-implemented strictly following [10] apart from the embedding size that we increased from 64 to 128. Our proposed systems are derived from this baseline SER system C_{em} .
- **ACRNN-r** : Addition of a regularization (described in 2.4) to C_{em} model to avoid class collapse.
- **SSA-CRNN-r** : A first ACRNN model C_{sp} (embedding z_{sp} of size 128) is dedicated to speaker recognition to learn high-level features that define the speaker identity, and from which our SSA mechanism will extract emotion salient information to inform the SER task covered by a second ACRNN model C_{em} (embedding z_{em} of size 128). Both models are trained jointly by mean of the SSA mechanism.

For evaluations, 10-fold cross validation technique is performed. Respectively for IEMOCAP and Att-HACK, *train/valid* split has been done randomly and linguistically. In particular, for IEMOCAP we split the whole set into ten parts randomly with different random seeds, for each fold the training set takes 80% and the validation set takes the remaining 20% of

the parts. For Att-HACK, the whole set is divided linguistically, 10 groups of 10 phrases are built randomly, 80 phrases are considered for training and 20 for validation.

Each module is optimized with respect to the cross-entropy objective function. Trainings are done with emotionally balanced mini-batches of 40 samples, using the Adam optimizer with Nestorov momentum. The initial learning rate is set to 0.0001 and the momentum is set to 0.9. The final model parameters are selected by maximizing the Unweighted Average Recall (UAR) on the validation set.

3.3. Experiment Results

As a first stage, we conducted speaker-dependant (SD) SER experiments. Indeed, in this configuration our system has not yet managed to generalize enough to unseen speakers. Table 1 is divided in two parts, the first part shows the results in UAR on IEMOCAP of the state-of-the-art SER system by [11]. The second part shows the UAR results of our proposed methods on both Att-HACK and IEMOCAP databases. First, our ACRNN re-implementation of the method described in [10] achieves 63.86% UAR performance for IEMOCAP in SD configuration not documented in [10].

Table 1: SD SER results with 95% confidence interval for different methods on Att-HACK and IEMOCAP in terms of UAR

SER system	Att-HACK	IEMOCAP
Meng et al. [11]	–	74.96 ± 4.27
ACRNN	36.97 ± 2.01	63.86 ± 2.23
ACRNN-r	67.15 ± 9.10	68.26 ± 2.57
SSA-CRNN-r	70.25 ± 4.36	77.22 ± 4.27

Next, we investigate the effectiveness of our proposed regularization. Compared with ACRNN, ACRNN-r obtains an absolute improvement of 30.18% on Att-HACK and 4.37% for IEMOCAP. This shows our regularization brings stability during training that allows the model to further recognize more subtle emotions. The confusion matrices depicted in Figure 4 also show the model is no longer over-focusing on one class, all the other classes are confused, with which was the case for dominant attitude in Att-HACK with the ACRNN.

To evaluate the addition of the SSA mechanism, we compare our proposal SSA-CRNN-r with ACRNN-r, it achieves an absolute improvement of 3.10 % for Att-HACK and 8.96 % for IEMOCAP. This shows combining emotion classification and speaker recognition through our SSA mechanism is relevant and lead to better capture speaker means of emotional expression. This conclusion is also supported by the examination of the temporal parts selected by the "self" and "speaker" part of the SSA mechanism. As shown in figure 3, both contributions seem independent and rather non redundant which means that SSA provides new salient information with regards to SER task.



Figure 3: Self and cross attribute attention scores α_{em} and α_{sp} for a given sample in IEMOCAP

Our proposal achieves a global absolute improvement of 33.28 % for Att-HACK and 13.36 % for IEMOCAP compared with ACRNN. Compared with the state-of-the-art SER system by Meng et al. [11], it achieves 2.26 % of UAR improvement on IEMOCAP.

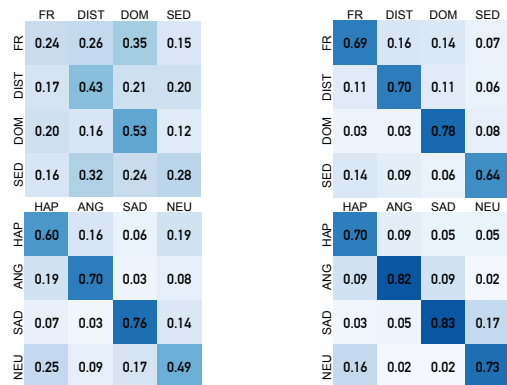

Figure 4: SER normalized confusion matrices where each row presents the class dependant prediction performance for Att-HACK (top) and IEMOCAP (bottom) and for ACRNN (left) and our proposal (right)

Finally, the t-SNE analysis in Figure 5 tend to show both attitudes and emotions are well separated in their respective embeddings. Although this point would need to be deeper investigated, we can further expect to use these embeddings in a voice conversion context as proposed by Zhou et al. in [22].

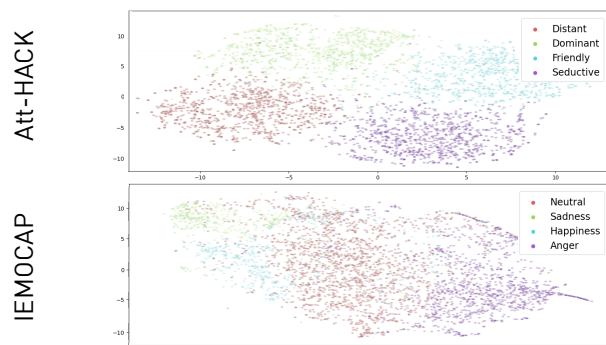

Figure 5: T-SNE representations obtained from emotion embeddings, for SSA-CRNN-r.

4. Conclusions

In this paper, we propose a Self Speaker Attentive Convolutional Neural Network (SSA-CRNN) model to train the SER model operating on 3D Log-Mel spectrograms and a novel training regularization that allows to avoid class collapse. The evaluation on Att-HACK and IEMOCAP databases demonstrates that the proposed method outperforms the state-of-the-art methods. Notably, the evaluation on IEMOCAP achieves 2.26 % absolute improvement of UAR compared with the SER system by Meng et al. [11] in speaker-dependant experiments. Further works will focus on the ability of our model to generalize to unseen speakers.

5. Acknowledgements

This research is supported by the MoVe project: "MOdelling of speech attitudes and application to an expressive conversational agent", and funded by the Paris Region Ph2D grant.

6. References

- [1] K. Scherer, "Vocal affect expression: a review and a model for future research." *Psychological bulletin*, vol. 99 2, pp. 143–65, 1986.
- [2] J.-A. Bachorowski, "Vocal expression and perception of emotion," *Current Directions in Psychological Science*, vol. 8, no. 2, pp. 53–57, 1999. [Online]. Available: <https://doi.org/10.1111/1467-8721.00013>
- [3] Q. Mao, M. Dong, Z. Huang, and Y. Zhan, "Learning salient features for speech emotion recognition using convolutional neural networks," *IEEE Transactions on Multimedia*, vol. 16, no. 8, pp. 2203–2213, 2014.
- [4] J. Lee and I. Tashev, "High-level feature representation using recurrent neural network for speech emotion recognition," 09 2015.
- [5] G. Keren and B. Schuller, "Convolutional rnn: An enhanced model for extracting features from sequential data," in *2016 International Joint Conference on Neural Networks (IJCNN)*, 2016, pp. 3412–3419.
- [6] G. Trigeorgis, F. Ringeval, R. Brueckner, E. Marchi, M. A. Nicolaou, B. Schuller, and S. Zafeiriou, "Adieu features? end-to-end speech emotion recognition using a deep convolutional recurrent network," in *2016 IEEE International Conference on Acoustics, Speech and Signal Processing (ICASSP)*, 2016, pp. 5200–5204.
- [7] S. Mirsamadi, E. Barsoum, and C. Zhang, "Automatic speech emotion recognition using recurrent neural networks with local attention," 03 2017.
- [8] M. Neumann and N. T. Vu, "Attentive convolutional neural network based speech emotion recognition: A study on the impact of input features, signal length, and acted speech," 2017.
- [9] G. Ramet, P. N. Garner, M. Baeriswyl, and A. Lazaridis, "Context-aware attention mechanism for speech emotion recognition," in *2018 IEEE Spoken Language Technology Workshop (SLT)*, 2018, pp. 126–131.
- [10] M. Chen, X. He, J. Yang, and H. Zhang, "3-d convolutional recurrent neural networks with attention model for speech emotion recognition," *IEEE Signal Processing Letters*, vol. 25, no. 10, pp. 1440–1444, 2018.
- [11] H. Meng, T. Yan, F. Yuan, and H. Wei, "Speech emotion recognition from 3d log-mel spectrograms with deep learning network," *IEEE Access*, vol. 7, pp. 125 868–125 881, 2019.
- [12] D. Ververidis, "Automatic speech classification to five emotional states based on gender information," 01 2004.
- [13] T. Vogt and E. André, "Improving automatic emotion recognition from speech via gender differentiation," in *LREC*, 2006.
- [14] L. Zhang, L. Wang, J. Dang, L. Guo, and Q. Yu, *Gender-Aware CNN-BLSTM for Speech Emotion Recognition: 27th International Conference on Artificial Neural Networks, Rhodes, Greece, October 4-7, 2018, Proceedings, Part I*, 09 2018, pp. 782–790.
- [15] Y. Li, T. Zhao, and T. Kawahara, "Improved end-to-end speech emotion recognition using self attention mechanism and multitask learning," 09 2019, pp. 2803–2807.
- [16] M. Sidorov, S. Ultes, and A. Schmitt, "Emotions are a personal thing: Towards speaker-adaptive emotion recognition," in *2014 IEEE International Conference on Acoustics, Speech and Signal Processing (ICASSP)*, 2014, pp. 4803–4807.
- [17] G. Assunção, P. Menezes, and F. Perdigão, "Speaker awareness for speech emotion recognition," *International Journal of Online and Biomedical Engineering (iJOE)*, vol. 16, p. 15, 04 2020.
- [18] A. Nagrani, J. S. Chung, and A. Zisserman, "Voxceleb: A large-scale speaker identification dataset," *Interspeech 2017*, Aug 2017. [Online]. Available: <http://dx.doi.org/10.21437/Interspeech.2017-950>
- [19] Z. Pan, Z. Luo, J. Yang, and H. Li, "Multi-modal attention for speech emotion recognition," 2020.
- [20] C. Le Moine and N. Obin, "Att-HACK: An Expressive Speech Database with Social Attitudes," in *Speech Prosody*, Tokyo, Japan, May 2020. [Online]. Available: <https://hal.archives-ouvertes.fr/hal-02508362>
- [21] C. Busso, M. Bulut, C.-C. Lee, A. Kazemzadeh, E. Mower Provost, S. Kim, J. Chang, S. Lee, and S. Narayanan, "Iemocap: Interactive emotional dyadic motion capture database," *Language Resources and Evaluation*, vol. 42, pp. 335–359, 12 2008.
- [22] K. Zhou, B. Sisman, R. Liu, and H. Li, "Seen and unseen emotional style transfer for voice conversion with a new emotional speech dataset," 2021.