



HAL
open science

Software architecture knowledge for intelligent light maintenance

Bernard Kamsu-Foguem, Yvan Mathieu

► **To cite this version:**

Bernard Kamsu-Foguem, Yvan Mathieu. Software architecture knowledge for intelligent light maintenance. *Advances in Engineering Software*, 2014, 67, pp.125-135. 10.1016/j.advengsoft.2013.09.003 . hal-03521161

HAL Id: hal-03521161

<https://hal.science/hal-03521161>

Submitted on 11 Jan 2022

HAL is a multi-disciplinary open access archive for the deposit and dissemination of scientific research documents, whether they are published or not. The documents may come from teaching and research institutions in France or abroad, or from public or private research centers.

L'archive ouverte pluridisciplinaire **HAL**, est destinée au dépôt et à la diffusion de documents scientifiques de niveau recherche, publiés ou non, émanant des établissements d'enseignement et de recherche français ou étrangers, des laboratoires publics ou privés.



Open Archive TOULOUSE Archive Ouverte (OATAO)

OATAO is an open access repository that collects the work of Toulouse researchers and makes it freely available over the web where possible.

This is an author-deposited version published in : <http://oatao.univ-toulouse.fr/>
Eprints ID : 11292

To link to this article : DOI:10.1016/j.advengsoft.2013.09.003
URL : <http://dx.doi.org/10.1016/j.advengsoft.2013.09.003>

To cite this version : Kamsu Foguem, Bernard and Mathieu, Yvan
Software architecture knowledge for intelligent light maintenance.
(2014) *Advances in Engineering Software*, vol. 67 . pp. 125-135. ISSN
0965-9978

Any correspondance concerning this service should be sent to the repository administrator: staff-oatao@listes-diff.inp-toulouse.fr

Software architecture knowledge for intelligent light maintenance

Bernard Kamsu-Foguem*, Yvan Mathieu

Laboratory of Production Engineering (LGP), EA 1905, ENIT-INPT, University of Toulouse, 47 avenue d'Azereix, BP 1629, 65016 Tarbes Cedex, France

A B S T R A C T

The maintenance management plays an important role in the monitoring of business activities. It ensures a certain level of services in industrial systems by improving the ability to function in accordance with prescribed procedures. This has a decisive impact on the performance of these systems in terms of operational efficiency, reliability and associated intervention costs. To support the maintenance processes of a wide range of industrial services, a knowledge-based component is useful to perform the intelligent monitoring. In this context we propose a generic model for supporting and generating industrial lights maintenance processes. The modeled intelligent approach involves information structuring and knowledge sharing in the industrial setting and the implementation of specialized maintenance management software in the target information system. As a first step we defined computerized procedures from the conceptual structure of industrial data to ensure their interoperability and effective use of information and communication technologies in the software dedicated to the management of maintenance (E-candela). The second step is the implementation of this software architecture with specification of business rules, especially by organizing taxonomical information of the lighting systems, and applying intelligence-based operations and analysis to capitalize knowledge from maintenance experiences. Finally, the third step is the deployment of the software with contextual adaptation of the user interface to allow the management of operations, editions of the balance sheets and real-time location obtained through geolocation data. In practice, these computational intelligence-based modes of reasoning involve an engineering framework that facilitates the continuous improvement of a comprehensive maintenance regime.

Keywords:

Conceptual modeling
Industrial maintenance
Semantic formalization
Web mapping service
Architectural pattern
Information system

1. Introduction

1.1. Objective

A French Engineering/Construction company spent a maintenance contract with Pulp and paper manufacturer, manufacturing paper sheets in a commune of the Haute-Garonne department in southwestern France. The contractual objective was to maintain at least 80% of the lighting places in operating condition, which means managing 15,000 spotlights. Disturbances in the light management system have severe impacts on company critical functions and its critical infrastructures. Hence, there is a need for an approach to intelligent maintenance analyses, which assists maintenance analysis of outages in the light management system and enables investigation of cascading failures and consequences in other infrastructures [19]. An important defy associated with the systemic view may be to create major scenarios for the analysis of interdependencies within critical infrastructures [5]. The engagement of an interoperability approach assessing the depen-

dencies among sub-areas demonstrates a valuable benefit in terms of resilience analysis [4]. In addition, the access to information and shared operating experience can exist with obtainable cross-fertilizations between safety and security engineering tools and methodologies [26].

Maintenance management information systems are indispensable to ensure control, gain knowledge and improve decision making [8]. The first step was to define the computerized procedures from conceptual structure of (formatting data that is calculated before in the Excel spread sheet) industrial data to ensure their good use, dedicated to the software maintenance management (E-candela). The second step was the setting, adapting the interface and implementation of the database of the software to allow contextual adaptation. And finally, the third step was to use the software, management of operations, editions of the balance sheets and geolocation. So, the software maintenance management employs contextual characterizations of situations to provide more relevant services or information to support users performing their tasks [31]. Likewise, it is possible to employ text mining approaches to classify material or immaterial resources into various categories based upon their geospatial features, with the aims to discovering relationships between resources and geographical zones [22]. Such

* Corresponding author.

E-mail address: Bernard.kamsu-foguem@enit.fr (B. Kamsu-Foguem).

method can detect real-time and geospatial event features for awareness of large-scale events and risk management [23] with pervasive computing for continuous location and resources monitoring [29].

1.2. Related works

Intelligent lighting systems have been described in the literature; there are some examples using the ZigBee remote sensing and management system [30]. The system comprises a group of measuring stations in the street and a base station positioned nearby [21]. The combination of ZigBee with other technologies (e.g. statistics of traffic flow magnitude, photosensitive detector (LDR), infrared photoelectric control) allows fault detection and feedback circuit to indicate the present state of the control system [32]. Hence the integrated framework permits ease of maintenance and substantial energy savings with improved performance. The method of group decision making can be incorporated to enhance the anti-interference capability and the intelligence level of the lighting control system [35]. In another domain, particularly an agricultural application, Olvera-Gonzalez et al., have proposed a LED (Light Emitting Diode)-based intelligent lighting system for plant growth [25]. Their intelligent illumination system (ILSys) examines changes in the chlorophyll fluorescence in different pulsed light treatments. Also, in the context of traffic safety with significant energy conservation, a fuzzy control procedure has been designed for tunnel lighting energy control systems [34]. However, the described applications are specifically fitting for street lighting in remote urban and rural areas. In contrast, our study involves examining an intelligent lighting system in an industrial setting for which installations are exposed to severe operating conditions, such as high temperature, projection of sparks and chemical irritants (air pollution and lubrication). A formal methodological framework has an important role to play in strengthening the industrial applications and increasing practical opportunities to support the development of intelligent environments [1]. More recently, Konrad Kułakowski et al. propose simulation experiments that allow testing the correctness of the design of the lighting inspection robot behavior model in the context of Knowledge-Behavior-Platform architecture [20]. This illustrates the need to add a knowledge dimension to the rationale behind methods for design and control of intelligent lighting systems. In our approach, we also introduce some semantic modeling characteristics [15], allowing us to achieve comprehensive reasoning mechanisms in our modeling processes with knowledge management dimension, thus facilitating information sharing and improving contextual adaptations.

2. The conceptualization for supporting maintenance processes

2.1. Proposition of the architecture for a generic model

We propose the conceptualization of a generic model for supporting and generating street lights maintenance processes. This model is based on a fully modular architecture to allow a certain level of suppleness in varying settings, making the information structuration and meta-data management by incremental mappings easy. The proposed architecture is conceptualized to provide a meaningfully more consistent organization (see Fig. 1).

The architecture is built as an assembly of a storage resource management and module layers, implementing different services useful for logical maintenance management. This development is entirely independent to the applications using the generic infrastructure. There are four types of modules: the data collection module acquires the data from target equipment, the data processing module computes operational data, the information visualiza-

tion module display data with images and the supervisor module controls architecture's behavior (start, stop and watchdog actions). Storage resource management includes optimizing the effectiveness and swiftness to allow better functionality and more advanced communications with interoperability requirements. The storage layer answers requests from other modules, informs the modules of updates and assures appropriate information exchanges between them with a dedicated network protocol and needed mechanisms of data structuration. With this generic model the specialized infrastructure can address some of the most difficult maintenance management challenges in the lighting sector. This includes the very different needs for lighting quality required by the industrial processes which often call for data warehousing, data mining, decision support and alert evaluation [14].

2.2. Software architecture modeling with the ECANDELA G2

ECANDELA G2 is a management software for the lighting place, developed by ATLOG. This software is adapted to the management of public lighting. It is complex software developed since 1995 by ATLOG very rich in resources for public lighting. His features are: fleet management across an organization in the form of sheets, it is possible to keep up to date the technical points of light, materials, control cabinets, ..., common interface between the database and mapping. It allows simplified entry of data, management consulting and customized user will facilitate to access the data by assigning access rights (filter on the common setting input masks by user, business functions or accessible (not entered, modification, access to interventions)) by user profile tools formatting data to allow export of office tools for statistics and reporting formats. There are management tools which follow interventions from the application to the work performed. Ecanдела software should allow the process shown below.

Software design patterns can lead to a methodological framework for improving interactive system architectures, and these patterns support the integration of usability in the software design process [9]. Design patterns such as Model-View-Controller (MVC) allow the interactive system architecture to be partitioned between the user interfaces and underlying functionalities [7]. MVC is an architectural pattern that separates the representation of information from the user's interaction with the different architecture components. The MVC components are defined in the following manner: the model is the application object, the view is the screen presentation, and the controller defines the way the user interface reacts to user input [33].

Fig. 2 delivers a better visibility of the software functions which is achieved through sets of intuitive specifications of the interactions between its components:

- The controller's role which is to do the operations (algorithmic calculations and tests) on the data (modeling the equipment (e.g. lighting and equipment) that are the subject of maintenance. It allows among others to calculate the age of the lamps and the date of next relamping (changing lamps).
- The model includes the database with all the references, types, brands and names of the lighting zones and workshops. It also includes ways of modeling syntax settings (data format) and semantic (content conveyed by the data).
- The view contains all the elements constituting the interface (architecture park lighting), mapping, a spread sheet that is containing the list of devices in the lighting place, and editing spreadsheets. The view shows all the elements that are intended to encourage user interaction with the system.

On the network architecture that is a client-server architecture, in which the server and client machines connected to the computer

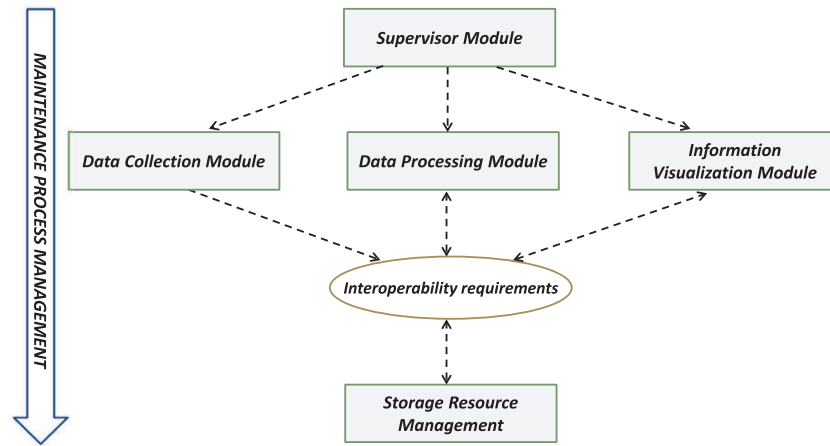

Fig. 1. Architecture of the proposed generic model.

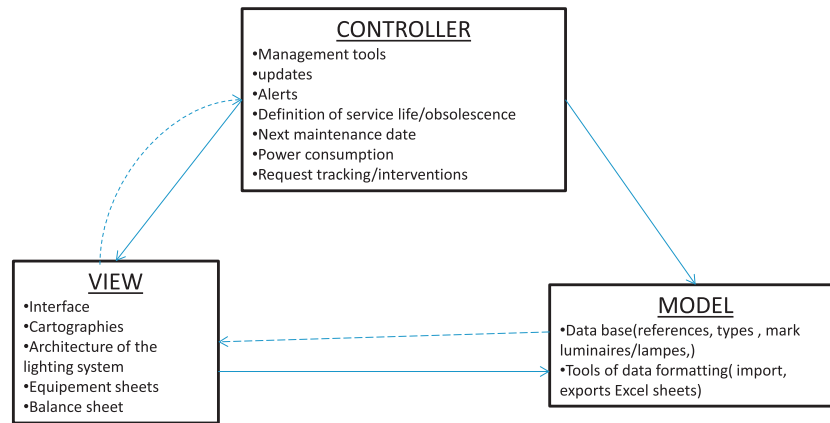

Fig. 2. A contextual collaboration of the MVC architecture components.

network are remote workstations. The servers are deployed to store data, manage users and connected it with a manager database (ORACLE). Particularly, FTP server is useful for document transfer, connection management ("borland socket server") with applications of ECANDELA server. The client makes the following procedures: consultation of park entry requests, updates of alphanumeric database and cartographic operating procedures. More specifically, the clients of ECANDELA application are micro-station that asks the following services: management of cadastral mappings, management of web mapping with Google Earth, structuration of Windows Excel information. ECANDELA also allows an analysis of digital picture files according to industrial specifications and the generated information enables geo tagging bright spots. The software includes the integration of maps made on AUTOCAD or MICROSTATION or Raster (scanned map, aerial photo, etc.). We have the tools MICROSTATION to edit the interface, manipulate and integrate maps to ECandela. The goal is to locate the light sources on a map in order to facilitate maintenance. The software is linked to Google Earth, it allows inserting the cadastral plan into a Google Earth plan of the manufacturing place and geo-referencing make it accessible remotely via the web interface ECANDELA.

The processes modeling of maintenance scenarios (Figs. 3 and 4) are made by using the Unified Modeling Language (UML) [3]. Particularly, we use the sequence diagram (see figure) and the collaboration (see Fig. 4) that provide two complementary viewpoints as part of a shared model. A sequence diagram displays object interactions organized in time order and it permits the specifica-

tion of temporal scenarios in a graphical manner. A collaboration diagram defines interactions among objects in terms of the orderly exchange of communications and it represents both the static structure and dynamic behavior of a system. These two complementary views create opportunities for examination and investigation actions by modelers and supported analysis by providing additional information and perspectives on the system for maintenance processes.

The first need is for allowing the customer (industrial site) to report an outage via the CMMS (Maintenance Management Computer Aided) that can be processed directly by the maintenance and this involves five actors (human or not, as described in Fig. 3):

- *Maintenance technicians*: they establish a diagnosis, require resources to maintain their system, and perform maintenance operations.
- *Business manager*: he receives reports of failures of the client, makes requests interventions for technicians and controls the products from suppliers. He also receives the maintenance reports of its technicians and notifies the customer when a maintenance operation was performed.
- *Light fixtures/appliances*: supplies (prone to failure) which undergo maintenance operations.
- *Suppliers*: receive and process orders and deliver them to maintenance.
- *Customer (Pulp and paper manufacturer)*: indicates failures on its industrial site.

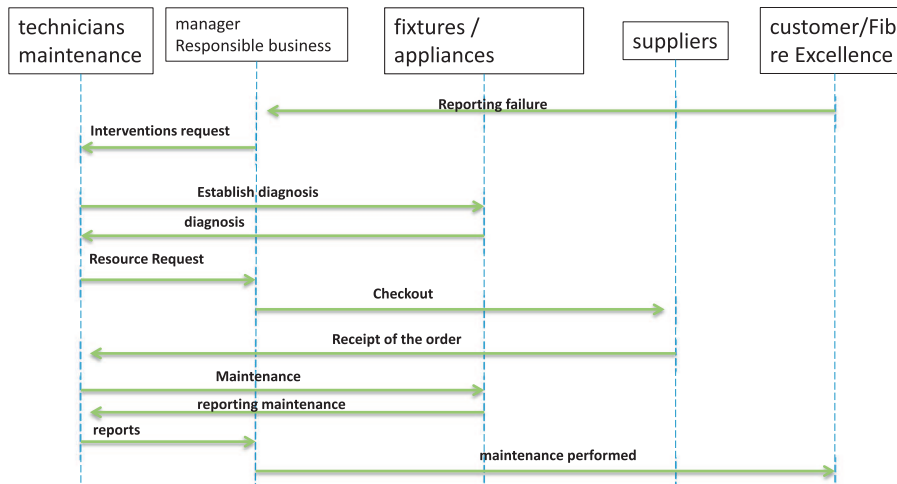

Fig. 3. A sequence diagram of the maintenance process.

3. Specification of computerized procedures

At first it was necessary to introduce computerized procedures in order to exploit the data. All industrial data were stored in Excel. The XLS file containing the data of the lighting places (studio, location, device number, comments) included many errors having some detrimental effects. These errors are due to the lack of clarity in information structuration and they were like accents, bad formalism, tripling see duplicates, missing data. Because of the number of duplicates and tripling the data contained in the XLS-file at the level of device numbers. It was impossible to create a database with the primary key device number. It was above all correct errors and complete data. In the XLS file the number of rows is 6207 and the number of columns is 16, it gives 99,312 data. We provide a preprocessing stage which performs the aforementioned errors filtering and prepares the data for the computerized procedures stages that follow. The first procedure was to Create in DEV C++ program for the conceptual structure of data (formatting syntax and semantic clarification (see Fig. 5)).

Working principle

We copied the data from the XLS file into a TXT file with a list of all the elements. The program will copy each element in two tables. We start the comparison from the element of an array i and $i + 1$ of the second table. When we see two or more times the same item we stock it in a third table. And the program will copy the contents of the third table in another TXT file (see Fig. 6).

4. Configuration, implementation of the database and adaptation of interface

4.1. Methodology of implementation and configuration data for ECANDELA G2

To configure the software in a proper manner, it was necessary to start with the creation of the architecture of the lighting places, one could even speak of an algorithm parameter that requires a working procedure. Following this procedure we start with creating the architecture of the place before filling the database and lighting systems. After creating the architecture of the lighting place of the factory, we had to create lighting systems and then inform the database by importing data that were structured and clarified in advance through computerized procedures (programs) created before. The data will be imported to complete the base and add all new elements of the architecture of the place created

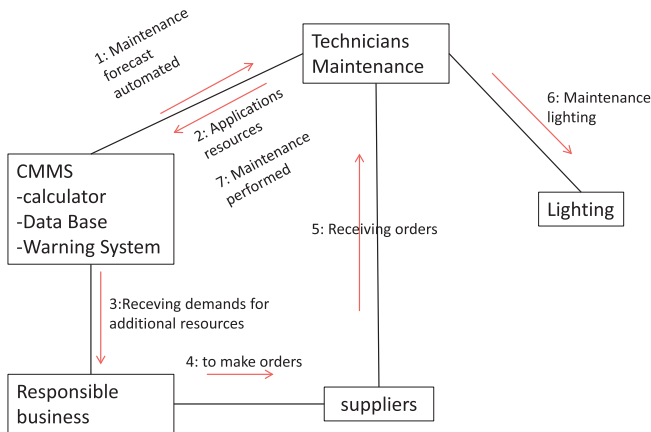

Fig. 4. A collaboration diagram of second way of the lighting system maintenance process.

The second need is for the technicians to perform preventive maintenance procedures through dependent data collection, automated calculations and routing (life and date of next lamps replacement (relamping)) and this also involves five actors (as described in Fig. 4):

- **Maintenance technicians:** they require resources for maintenance via the CMMS and perform maintenance of the light fixtures, and finally provide information about maintenance operations performed so that one can calculate the conditions of obsolescence or normal wear.
- **CMMS:** it prevents maintenance technicians about any scheduled maintenance operations and forwards requests of resources to business manager.
- **Lighting/equipment:** these systems are prone to failures and we shall periodically review the maintenance results for evidence of incipient or recurring failures.
- **Suppliers:** they receive and process orders concerning the potential malfunctions that may occur during any phase of the system lifecycle and deliver them to maintenance service.
- **Business manager:** being directly informed by the CMMS of maintenance requirements, to get needed material resources, the business manager can order from manufacturers/suppliers, he will have to check quality and also delivery times.

```

(Portée inconnue)
#include <cstdlib>
#include <stdio.h>
#include <iostream>
#include <fstream>
#include <string>
#include <string.h>

using namespace std;

int main(int argc, char *argv[])
{
    string ligne, ligne2[40000], *tab[40000], tab2[40000], tab3[40000];
    int log;
    //tab = tab2 = tab3 = new string;
    int c=0, h=0;
    int t;
    int i=0, e=0, p=0;
    ifstream alpha("D:/num.txt");

    // while(getline(alpha, ligne))
    {
        //c=c+1;
        //for(int i = 0; i = "void";i++)
        // cout<<ligne<<endl;
    }
    //t=c;

    //cout<<t<<endl;

    //alpha.seekg(0, ios::beg);
    while(getline(alpha, ligne ))
    {
        //for(int i =0; i<t;i++)
        {
            tab[i]= &ligne;
            tab3[h]=tab2[e]= *tab[i];

            c=c+1;

            // cout<<tab3[h]<<*&tab[i]<<endl;
            i++;
            e++;
            h++;
        }
    }
}

```

```

double3.txt - Bloc-notes
Fichier Edition Format Affichage ?
90 00 382
90 00 383
90 00 384
90 00 385
90 00 386
90 00 387
90 00 388
90 00
90 00 355
90 00 356
90 00 351
90 00 359
90 00 360
90 00 376
90 00 377
90 00 378
90 00 379
90 00 380
90 00 381
90 05 45
90 05 200
90 10 400
90 10 402

```

Fig. 6. Program to detect duplicates.

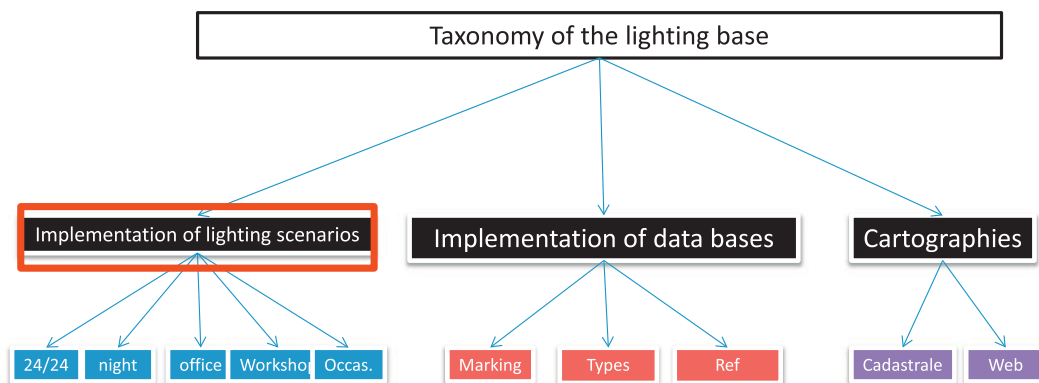

Fig. 7. Global method of organization and prioritization of concepts for the implementation of data.

and integrate maps to ECandela. The goal is to put on a map the light sources in order to facilitate maintenance. The plans of DWG are available in a number of workshops of the industrial site and a com-

prehensive plans base is provided with the instruments to bridge the gaps at our disposal. The idea is to integrate the base plan as a reference and place plans over it for each workshop and factory. Each map

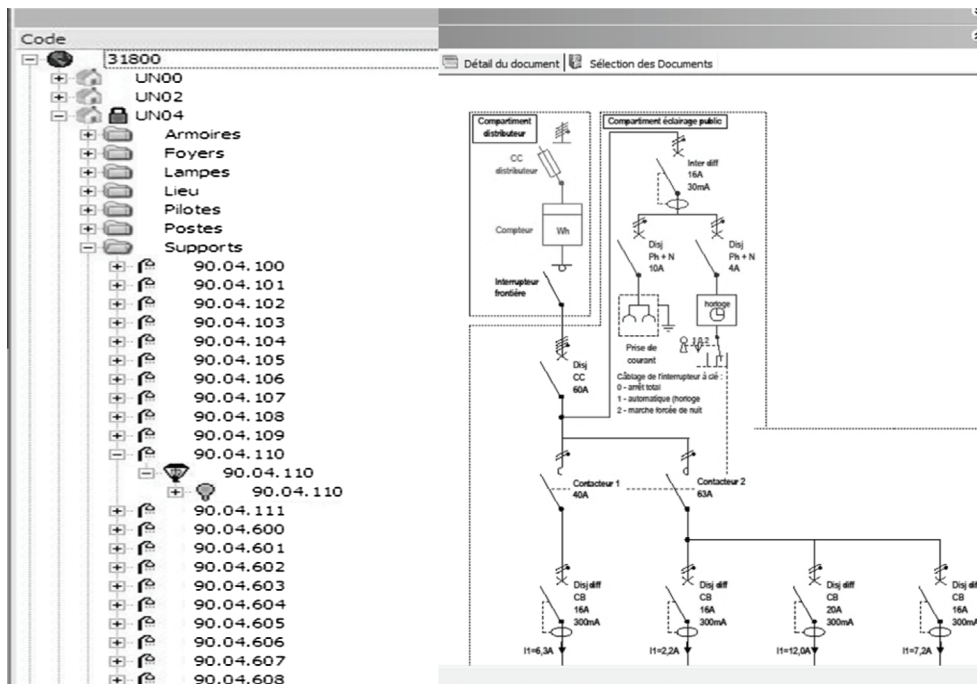

Fig. 8. Taxonomy of the lighting base created on the ECANDELA interface.

Régimes d'éclairage:

Code	Libellé	Commentaires	Variateur
24	Permanent toute l'année	Permanent toute l'année	<input type="checkbox"/>
REG1	SP 22H/6H30 SAUF 25/12 PERMAENT	Semi permanent 22H/6H30	<input type="checkbox"/>
REG2	SP 22H/7H	Semi permanent 22H/7H	<input type="checkbox"/>
REG3	SP 22H30/5H30	Semi permanent 22H30/5H30	<input type="checkbox"/>
REG4	SP 23H/5H	Semi permanent 23H/5H	<input type="checkbox"/>
REG5	SP 0H/5H	Semi permanent 0H/5H	<input type="checkbox"/>
REG6	SP 0H/6H	Semi permanent 0H/6H	<input type="checkbox"/>
REG7	SP 22H/7H WE 0H/7H	SP 22H/7H WE 0H/7H	<input type="checkbox"/>
REG8	SPS ETE 0H/5H HIVER 22H/7H	SPS ETE 0H/5H HIVER 22H/7H	<input type="checkbox"/>

Code	Libellé	Couleur	Lundi	Mardi	Mercredi	Judi	Vendredi	Samedi	Dimanche
PH	Permanent Hebdo	0-							
SP2	SP 22h/7h	2-							
SP3	SP 22h30/5h30	4-							
SP4	SP 23h/5h	6-							
SP5	SP 0h/5h	8-							
SP6	SP 0h/6h	10-							
SP7	SP 22/7 WE 00/7	12-							
SP1	SP 22h/6h30	14-							
PHV1	PVAR 23H/5H 50%	16-							
toto	essai	18-							
		20-							
		22-							
		24-							

Fig. 9. Relevant operating regimes.

will be linked to an area and places themselves are linked to the data that form the basis. This will allow access to all data for a luminaire directly by clicking on the map. During the implementation we take

good mapping to align the bottom of the cadastral map in a coordinate system, like *Lambert 3* that allows us the geo-referencing and visualization via Google Earth.

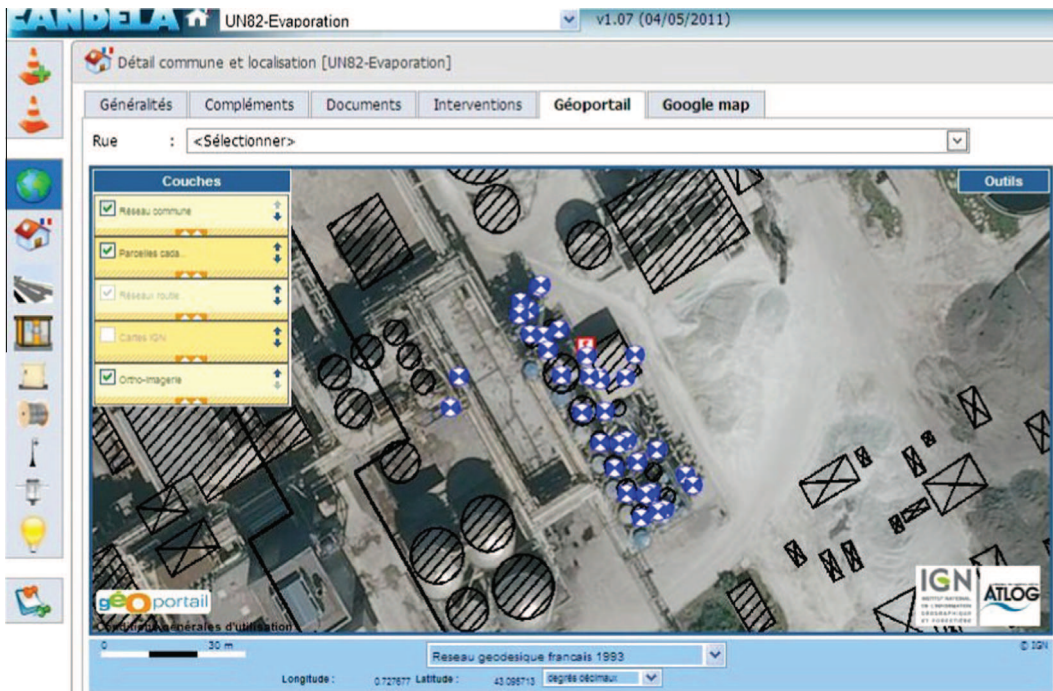

Fig. 10. Cartography with lighting materialized in blue and white.



Fig. 11. A user-friendly web interface.

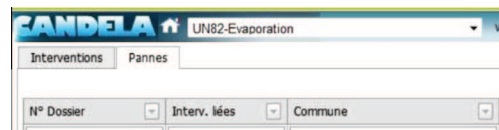

Fig. 13. The data entry tab.

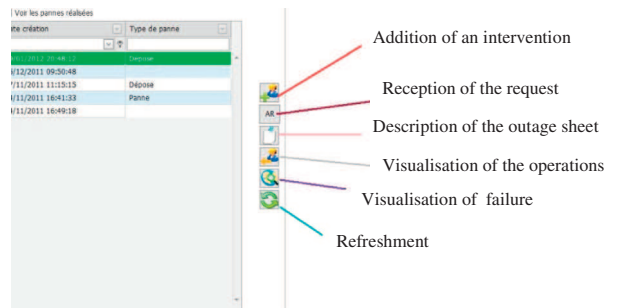

Fig. 14. The window for intervention management.

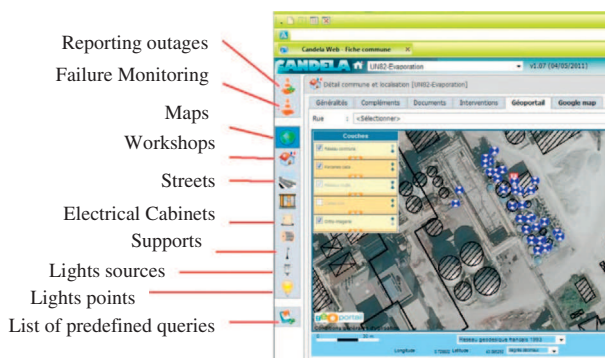

Fig. 12. Web mapping service.

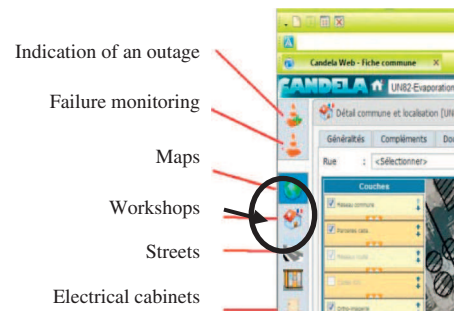

Fig. 15. Options for tracking and reporting complaints or failures.

Mapping has the aim to facilitate the work of technicians and make it more effective. Each luminaire appears on the map that is directly connected to the architecture of the lighting places created through cross-links (zones, places). Mapping allows many possible uses, such as the reporting of failures by selecting the

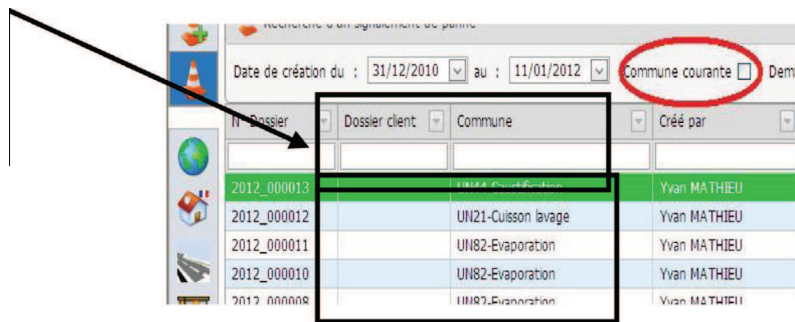

Fig. 16. Search by geographic workshop.

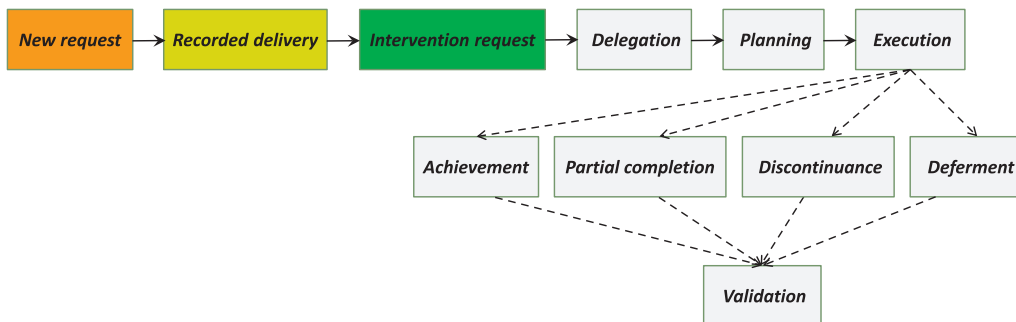

Fig. 17. Information about the progress of a request for intervention.

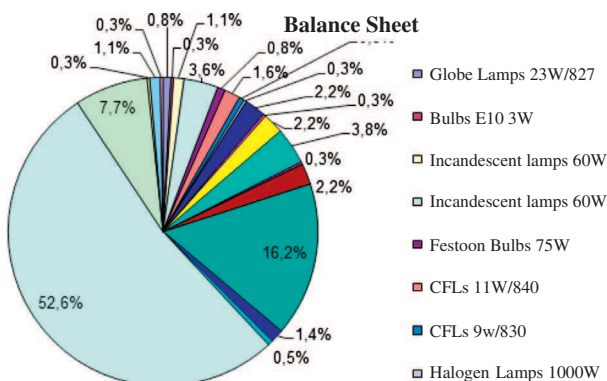

Fig. 18. The distribution of different lights in the target business organization.

fixture directly on the map. In the same vein, it is possible to incorporate a mixture of content-based and collaborative recommendation strategies in which recommended activities are shown according to user's location [2].

5. Operating of the software: maintenance technician training program

5.1. Consultation and reporting failures

One can use the software to check current objectives and discover new information, as well to report some failures. In order to achieve this, one need to make the following instructions:

- (1) Click on select a town up in the bar/select the workshop of your choice.
- (2) You can visualize through "geoportail" or "googlemap" geographical location, physical homes.

More specifically, there are three ways to report an outage:

- (1) To report a fault then click on the icon on the left bar. A window opens where you can enter the type of failure detected, and the exact place and add one more observation.
- (2) You can report an outage directly from an example: "click lamps, choose a lamp check by clicking on the icon at the bottom of the window indicate a failure" and you will create a geographical breakdown located.
- (3) Third way, clicking on the item via either Google maps or GeoPortail or you can directly create a failure. To view the reports, one can click on the second icon from the top bar on the left.

Entry procedures

- (1) You will see two tabs "interventions" and "failure"
- (2) The tab is used to create interventions visualize change or delete an intervention, or an element of the work.
- (3) The tab is used to create fault interventions from a given fault, and view and manage the progress of interventions in relation to failures.

To see a summary of all requests/reporting faults on the entire site Pulp and paper manufacturer, we make the supplementary synthesis using Candela web version 1.7 for client/user, with the following steps:

- (1) In the consultation report outages choose any workshop. Click the "track fault".
- (2) Then simply "uncheck" the box circled in red "common standard" then "change the date of creation" (to this end to refresh the list below) you will see all requests appear on all workshops Pulp and paper manufacturer.

- (3) You can also import a list of all troubleshooting requests by clicking on the record of each maintenance intervention which contains all information necessary to enable operations to be processed and controlled by the actors and participating services.

5.2. Management of interventions and editions of balance sheets

This program will aim to optimize the maintenance of the industrial site. By a system of management interventions that will allow us to make and manage requests and interventions as well as interventions undertaken on each device. We can directly follow the progress and status of each fixture, lamp or appliance park, in real time. When one has a request for assistance an email is sent directly from Engineering/Construction company for information. This allows optimization of maintenance. In addition the implementation of user-adapted interestingness measures can apply to interventions in business-as-usual projects that show both sustainable and qualitative added values.

This information about interventions is indicated in the following list of main components of activity (see Fig. 17).

- Service request form (phone call, a fax transcript, night round's balance sheet or the product of applications planning)
- Details of a request: diagnostics of structural, functional, and behavior aspects of elements implicated in the service request. This can go to the detail of lamps to troubleshoot.
- Outages: description of problems.
- Intervention: it corresponds to a technical operation in the industrial setting.
- Work done: types of interventions that have been made.
- Consequences: scheduled actions that cause the display of an input screen for validation or change in the characteristics and nature of the object that is maintained in the system.

We can also view the history of actions and demands associated with each lamp. In addition, you can even make statistics of causes of requests for assistance; make editions of the balance sheets as histograms, diagrams, curves, or Excel spreadsheet (see Fig. 18).

5.3. Discussion

The use of E-Candela, allows to optimize the management of lighting including maintenance of 80% of the lighting Park. E-Candela has tools for calculating the lamps life, well as the calculation of the next dates of replacing the bulbs. Its calculation tools are based on hours of fundraising and reclining Sun during the year. This allows knowing more details about the hours of operations of lamps. Its response management system, allows the users technicians and supervisors to communicate and follow in real time current maintenance work. However the use of the software requires at least 1 or 2 days of training courses in order to truly understand the workings of the different tools that provide E-candela. And it requires understanding the architecture of the lighting Park in order to model it. We can add that the use of the software requires setting up a fairly accurate mapping made by a software application for both 2D and 3D computer-aided design and drafting with all light points above.

E-Candela has enabled the maintenance technicians to save time and improve their working conditions. The technicians having no longer to move, they can use the time for preventive maintenance such as corrective maintenance time. This represents a gain in the efficiency of the maintenance, with distinctive opportunities of rigorous testing procedures [12]. In addition, organizing workshops on experience feedback may help to give people an opportunity to learn new skills to balance quality and productivity

requirements as well as providing an opportunity for sharing expertise and problem-solving.

The deployment of an intelligent light management system takes place in strategic measures that reflects an effort to reconcile the conflicting needs of industry and the energy consumption that has a relationship with economic growth [6]. This system is an effective way to control energy consumption, since the provided tools meet the needs of the industrial process monitoring while also providing users what they need to balance their activities and maintenance actions. In reference to the green economy, this energy consumption reduction objective applies to lighting energy consumption. The majority of benefits gained from rationalization and optimization of maintenance actions influence a sustainable use of industrial devices and a modern approach of working for people dependent on these activities. It also gives maintenance managers practical insights and valuable tips to better integrate their contextual economic, technological and planning constraints with their surroundings on a daily basis. In view of these contextual constraints, any improvement which raises the energy efficiency of material resources supporting the industrial activities with real time information is always to be welcomed. Interactive communication resources and real time information delivered by the intelligent system emphasizes dysfunctions as they occur [18], enabling managers to take applicable actions to maximize maintainability and productivity.

6. Conclusion

This project helps to highlight several important insights with some valuable lessons. Firstly the importance of taxonomy that is to say, the importance of structuring domain concepts, by arranging the various hierarchically organized and the elements of the industrial lighting system. For example we made the following structuration from high level concepts to low level concepts: Pulp and paper manufacturer (industrial site name) → Workshops → Electrical Cabinets → media → Fireplaces → Lamps → The appliances. We created cross-links between the various components of the lighting management system. These cross-links were intended to establish relationships between other types of data such as the contents of the cabinets or electrical mapping and elements of the taxonomy. Consequently, the taxonomy is essential in order to organize the data in the database and information. This allowed facilitating the process of the information of the database, and especially to ease the understanding of the organization of industrial lighting system and create links between the lighting system equipment and database. Sometimes, the formalization processes have focused on high-level concepts and recommendations have been more general in nature [11]. In practice, our methodological proposal is flexible enough to express high level concepts without generating a loss of performances.

The second important point is the process of formatting data. Indeed, in order to create links between the elements of the lighting system and the database, information should be strategically packaged and written if it is to capture the context of intended manipulations. We must first format the data that is to say, the removal of duplicates, accents and special characters, and especially the inclusion of missing information. Substantial work is required to reduce the amount of data produced. This is achieved by creating appropriate computerized procedures that format the data for requirements distribution and to complete a user program to easily view results and perform monitoring simulations. This is of particular benefit to provide a mechanism for creating a database of known monitored resources and a process by which the profile data can be formatted for entry into the maintenance management system [27].

The third step was the establishment of cartographies. Indeed this is the key point which constitutes an important element of the intelligent maintenance project. This step is the synthesis of all the steps performed before and it offers an instrument which allows sharing maintenance expertise, information and abilities. Actually, it allows real-time visualization of the lamps on a map. To date it has been necessary to implant the cartography of each workshop and factory in order to obtain more precise measurements. We had established these mappings of lamps constituting the lighting system. These lamps can be materialized by circles of different colors with further specific geometrical distinctive features. Having created the maps we had to comply with a coordinate system, like *Lambert 3*, in order to connect them to Google Earth. The usefulness of the link to Google Earth is the implementation of a geographical tracking of lamps directly to Google Earth. This allows continuously updating the mapping of the factory and seeing very accurate installations. The maps and locators function also draws on the latest developments in search and location capabilities to enhance staff productivity in a mobile environment. Finally, these location-based applications help reduce the number of phone calls to maintenance services and improve their ability to provide current and accurate information to the customers they serve.

References

- [1] Augusto Juan Carlos, Hornos Miguel J. Software simulation and verification to increase the reliability of intelligent environments. *Adv Eng Softw* 2013; 58(April):18–34.
- [2] Batet Montserrat, Moreno Antonio, Sánchez David, Isern David, Valls Aïda. *Turist@*: agent-based personalised recommendation of tourist activities. *Exp Syst Appl* 2012;39(8):7319–29.
- [3] Booch Grady, Rumbaugh James, Jacobson Ivar. *The unified modeling language user guide*. 2nd ed. Addison-Wesley Professional; 2005. Hardcover: 496 p. ISBN-10: 0321267974, ISBN-13: 978-0321267979.
- [4] Cagno Enrico, De Ambroggi Massimiliano, Grande Ottavio, Trucco Paolo. Risk analysis of underground infrastructures in urban areas. *Reliab Eng Syst Saf* 2011;96(1):139–48.
- [5] Eusgeld Irene, Nan Cen, Dietz Sven. "System-of-systems" approach for interdependent critical infrastructures. *Reliab Eng Syst Saf* 2011;96(6):679–86.
- [6] Fondja Wandji DYris. Energy consumption and economic growth: evidence from Cameroon. *Energy Policy* 2013;61(October):1295–304.
- [7] Goldberg A. *Smaltalk-80: the interactive programming environment*. Addison-Wesley Publ.; 1984.
- [8] Gómez Fernández Juan Francisco, Crespo Márquez Adolfo. Framework for implementation of maintenance management in distribution network service providers. *Reliab Eng Syst Saf* 2009;94(10):1639–49.
- [9] Hasan SS, Isaac RK. An integrated approach of MAS-CommonKADS, Model-View-Controller and web application optimization strategies for web-based expert system development. *Exp Syst Appl* 2011;38(1):417–28.
- [10] Hicham Jabrouni, Bernard Kamsu-Foguem, Laurent Geneste, Christophe Vaysse. Analysis reuse exploiting taxonomical information and belief assignment in industrial problem solving. *Comput Ind.* 2013;64(8):1035–44.
- [11] Bernard Kamsu-Foguem, Daniel Noyes. Graph-based reasoning in collaborative knowledge management for industrial maintenance. *Comput Ind.* 2013;64(8):998–1013.
- [12] Kamsu Foguem, Bernard and Simeu, Emmanuel. Optimizing construction of scheduled data flow graph for on-line testability. *Mediterr J Comput Networks* 2012;8(4):125–133. ISSN 1744-2397.
- [13] Bernard Kamsu-Foguem, Germaine Tchuenté-Foguem, Clovis Foguem. Using conceptual graphs for clinical guidelines representation and knowledge visualization. *Information Systems Frontiers*, <http://dx.doi.org/10.1007/s10796-012-9360-2>.
- [14] Kamsu-Foguem Bernard, Rigal Fabien, Mauget Félix. Mining association rules for the quality improvement of the production process. *Exp Syst Appl* 2013;40(4):1034–45.
- [15] Kamsu-Foguem Bernard, Diallo Gayo, Foguem Clovis. Conceptual graph-based knowledge representation for supporting reasoning in African traditional medicine. *Eng Appl Artif Intell* 2013;26(4):1348–65.
- [16] Kamsu-Foguem B, Coudert T, Béler C, Geneste L. Knowledge formalization in experience feedback processes: an ontology-based approach. *Comput Ind* 2008;59(7):694–710.
- [17] Kamsu-Foguem Bernard. Knowledge-based support in non-destructive testing for health monitoring of aircraft structures. *Adv Eng Inform (ADVEL)* 2012;26(4):859–69.
- [18] Kamsu-Foguem Bernard, Tchuenté-Foguem Germaine, Allart Laurent, Zennir Youcef, Vilhelm Christian, Mehdaoui Hossein, et al. User-centered visual analysis using a hybrid reasoning architecture for intensive care units. *Dec Supp Syst* 2012;54(1):496–509.
- [19] Kjølle GH, Utne IB, Gjerde O. Risk analysis of critical infrastructures emphasizing electricity supply and interdependencies. *Reliab Eng Syst Saf* 2012;105(September):80–9.
- [20] Kułakowski Konrad, Matyasik Piotr, Ernst Sebastian. Modeling indoor lighting inspection robot behavior using concurrent communicating lists. *Exp. Syst. Appl.*, in press. <http://dx.doi.org/10.1016/j.eswa.2013.06.065>.
- [21] Leccese F, Leonowicz Z. Intelligent wireless street lighting system. In: 11th International conference on environment and electrical engineering (EEEIC), 18–25 May 2012. p. 958, 961.
- [22] Lee Chung-Hong, Wang Shih-Hao. An information fusion approach to integrate image annotation and text mining methods for geographic knowledge discovery. *Exp Syst Appl* 2012;39(10):8954–67.
- [23] Leccese F, Leonowicz Z. Mining spatio-temporal information on microblogging streams using a density-based online clustering method. *Exp Syst Appl* 2012;39(10):9623–41.
- [24] Musen Mark A. The knowledge acquisition workshops: a remarkable convergence of ideas. *Int J Hum-Comput Stud* 2013;71(2):195–9.
- [25] Olvera-Gonzalez Ernesto, Alaniz-Lumbreras Daniel, Ivanov-Tsonchev Rumen, Villa-Hernández Jesus, Olvera-Olvera Carlos, González-Ramírez Efrén, et al. Intelligent lighting system for plant growth and development. *Comput Electron Agric* 2013;92(March):48–53.
- [26] Piètre-Cambacédès L, Bouissou M. Cross-fertilization between safety and security engineering. *Reliab Eng Syst Saf* 2013;110(February):110–26.
- [27] Potes Ruiz Paula, Kamsu-Foguem Bernard, Noyes Daniel. Knowledge reuse integrating the collaboration from experts in industrial maintenance management. *Knowl-Based Syst* 2013;50(September):171–186.
- [28] Sánchez David, Batet Montserrat. A semantic similarity method based on information content exploiting multiple ontologies. *Exp Syst Appl* 2013;40(4):1393–9.
- [29] Soria Morillo LM, Ortega Ramírez JA, Alvarez García JA, Gonzalez-Abril L. Outdoor exit detection using combined techniques to increase GPS efficiency. *Exp Syst Appl* 2012;39(15):12260–7.
- [30] Valente A, Morais R, Serodio C, Mestre P, Pinto S, Cabral M. A ZigBee sensor element for distributed monitoring of soil parameters in environmental monitoring. In: 2007 IEEE Sensors, 28–31 October 2007. p. 135–8.
- [31] Vieira Vaninha, Tedesco Patricia, Salgado Ana Carolina. Designing context-sensitive systems: an integrated approach. *Exp Syst Appl* 2011; 38(2):1119–38.
- [32] Vipasha, Abrol Preeti. Design of traffic flow based street light control system. *Int J Comput Appl* 2013;72(18):32–7 [FoundationofComputerScience, NewYork, USA].
- [33] Weisfeld Matt A. *The object-oriented thought process*. Sams Publishing. p. 239. ISBN 9780672326110.
- [34] Zeng Hong, Qiu Jian, Shen Xingfa, Dai Guojun, Liu Peng, Le Shuping. Fuzzy control of LED tunnel lighting and energy conservation. *Tsinghua Sci Technol* 2011;16(6):576–82.
- [35] Zhang Jun, Qiao Guifang, Song Guangming, Sun Hongtao, Ge Jian. Group decision making based autonomous control system for street lighting. *Measurement* 2013;46(1):108–16.