



HAL
open science

Geographical Islands Flexibility: technological scenarios and recommendations

Sophie Chlela, Giulia Grazioli, Sandrine Seloisse, Nadia Maïzi, Evangelos Rikos, Isidoros Kokos, Iasonas Kouveliotis-Lysikatos, Ilias Lamprinos And Nikos Ioannidis, Bogdan Floares, Joep Lauret And Krishna Pattamatta, et al.

► To cite this version:

Sophie Chlela, Giulia Grazioli, Sandrine Seloisse, Nadia Maïzi, Evangelos Rikos, et al.. Geographical Islands Flexibility: technological scenarios and recommendations. [Research Report] Centre for Applied Mathematics (CMA / ARMINES / MINES Paris) - H2020 GIFT Project. 2021. hal-03512788

HAL Id: hal-03512788

<https://hal.science/hal-03512788>

Submitted on 17 Jan 2022

HAL is a multi-disciplinary open access archive for the deposit and dissemination of scientific research documents, whether they are published or not. The documents may come from teaching and research institutions in France or abroad, or from public or private research centers.

L'archive ouverte pluridisciplinaire **HAL**, est destinée au dépôt et à la diffusion de documents scientifiques de niveau recherche, publiés ou non, émanant des établissements d'enseignement et de recherche français ou étrangers, des laboratoires publics ou privés.

Deliverable D2.4

TECHNOLOGICAL SCENARIOS AND RECOMMENDATIONS



Geographical Islands Flexibility

Organisation: [ARMINES](#)

Main authors: [Sophie CHLELA](#), [Giulia GRAZIOLI](#), [Florian MARCHAT](#), [Sandrine SELOSSE](#), [Nadia MAÏZI](#)

Contributors: [Evangelos Rikos](#), [Isidoros Kokos](#), [Iasonas Kouveliotis-Lysikatos](#), [Ilias Lamprinos](#) and [Nikos Ioannidis \(ICOM\)](#), [Bogdan Floares](#), [Joep Lauret](#) and [Krishna Pattamatta \(ELESTOR\)](#), [Jure Ratej \(ETREL\)](#), [Manuela Frete \(Harstad municipality\)](#), [Rune Nyrem Kristensen \(HLK\)](#), [Lizhen HUANG](#), [Dejene Assefa HAGOS](#), [Wenji ZHOU](#), [Yongping LIU](#) and [Alemayehu Gebremedhin \(NTNU\)](#), [Luc Richaud \(Odit-e\)](#), [Davide Cozzella](#), [Anna Imputato](#), [Antonio Carannante](#) and [Pierpaolo Ambrosino \(Procida Municipality\)](#), [Davide Astiaso Garcia](#), [Daniele Groppi](#), [Mario Lamagna](#) and [Benedetto Nastasi \(Sapienza University of Rome\)](#), [Caroline Rozain](#) and [Marc Potron \(SYLFEN\)](#), [Marjolaine Farré](#), [Dune Sebilleau](#) and [Olivier Genest \(TRIALOG\)](#)

Date [30/06/2021](#)



This project has received funding from the European Union's Horizon 2020 research and innovation program under grant agreement No 824410.



DELIVERABLE 2.4 – VERSION 5

WORK PACKAGE N° 2

Nature of the deliverable			
R	Document, report (excluding the periodic and final reports)		X
DEM	Demonstrator, pilot, prototype, plan designs		
DEC	Websites, patents filing, press & media actions, videos, etc.		
OTHER	Software, technical diagram, etc.		
Dissemination Level			
PU	Public, fully open, e.g. web		X
CO	Confidential, restricted under conditions set out in Model Grant Agreement		
CI	Classified, information as referred to in Commission Decision 2001/844/EC		
Quality procedure			
Date	Version	Reviewers	Comments
26/12/2019	V4	Benoit Faivre (EQY)	
25/06/2021- 28/06/2021	V5	NTNU (Lizhen HUANG and Dejene Assefa HAGOS)	

ACKNOWLEDGEMENTS

The project Geographical Islands FlexibiliTY (GIFT) has received funding from the European Union’s Horizon 2020 research and innovation programme under grant agreement No 824410. The sole responsibility for the content of this publication lies with the authors. It does not necessarily reflect the opinion of the Innovation and Networks Executive Agency (INEA) or the European Commission (EC). INEA or the EC are not responsible for any use that may be made of the information contained therein.

More information on the project can be found at <http://www.gift-h2020.eu/>

We would also like to give special thanks to our partner in the GIFT project, NTNU, and in particular Lizhen HUANG, Dejene Assefa HAGOS Wenji ZHOU and Yongping LIU, for their help in the realisation of this task 2.3. The prospective analysis that we have developed for the Norwegian territory was indeed carried out using the TIMES-HINNOYA model developed by NTNU.

COPYRIGHT

© GIFT Consortium. Copies of this publication – also of extracts thereof – may only be made with reference to the publisher.

EXECUTIVE SUMMARY



The European project H2020 GIFT (Geographical Islands Flexibility) led by INEA aims to decarbonise the energy mix of European islands by developing and installing innovative systems that significantly increase the penetration of variable renewable energy (VRE) sources into the islands' energy mix. The first step is to develop and demonstrate solutions in two pilot islands, Hinnøya in Norway and Procida in Italy, with totally different but complementary contexts, while studying the replicability of solutions in other islands. This document is the preliminary GIFT deliverable 2.4 "Technological scenarios and recommendations". It aims to provide a preliminary model of the energy system of Hinnøya island cluster and Procida that developed using the TIMES modelling environment and alternative technical and policy scenarios tailored in order to analyse the future development of the energy system of the aforementioned islands. It considers different technical and/or regulatory scenarios including, among others, the environmental and energy implications of active and new energy and climate policies but also possible technological developments. The analysis of these scenarios would deliver alternative technical and regulatory long-term decarbonisation strategies.

The intermittency of VRE sources in the electricity system imposes a major challenge on the transmission and distribution grid stability. The need to balance the power surplus and deficit at any instant calls for a major transformation in the traditional electricity network and energy system at large. For smooth integration of VRE sources, the electric system required to be flexible and resilient, i.e. being able to reliably respond to changes in demand or uncertainties at reasonable costs. The flexibility of an electricity system strongly depends on the production mix that constitutes it, that must include base capacities and operational reserves. It is then important to choose the best production mix that guarantees the satisfaction of the demand at all times. To this end, the application of long-term model deemed suitable and appropriate. Indeed, this approach allows to determine the optimal types of technologies to use and their corresponding required capacities vis-a-vis technological, environmental, political and social constraints.

Firstly, this report brings into context the issues surrounding the flexibility of systems and the integration of VREs in island territories. Secondly, the possible ways for Procida in Italy and Hinnøya island cluster in Norway are analysed with based on the results obtained by using the technology-rich, bottom-up energy system model TIMES. The two developed models attempt to integrate flexibility options. The long-term discussion for each island included the use of technologies promoted by the project and relevant for the island itself. In addition, other solutions were explored for a comprehensive assessment regarding the grid flexibility of the islands. Key findings and recommendations were delivered for each island and for the project as a whole.



TABLE OF CONTENTS

ACKNOWLEDGEMENTS	1
COPYRIGHT	1
EXECUTIVE SUMMARY	1
TABLE OF CONTENTS.....	3
LIST OF FIGURES	5
LIST OF TABLES	7
LIST OF ABBREVIATIONS.....	8
1. INTRODUCTION	11
1.1. BACKGROUND	11
1.2. ABOUT GIFT	12
1.3. SCOPE OF THE DOCUMENT	13
2. INCREASING THE SHARE OF RENEWABLE ENERGY IN POWER SYSTEMS	13
2.1. GENERAL CONTEXT	13
2.2. RATIONALE FOR ISLANDS.....	14
2.2.1. Decarbonization.....	14
2.2.2. Energy Autonomy.....	15
2.2.3. Exploitation of local resources	15
3. FLEXIBILITY OF POWER SYSTEMS	16
3.1. GRID STABILITY AND THE FLEXIBILITY OF POWER SYSTEMS.....	16
3.2. FLEXIBILITY AND RENEWABLE ENERGY INTEGRATION IN THE POWER SYSTEM	17
3.3. TECHNICAL ASPECTS OF INTEGRATING RENEWABLE ENERGY IN POWER SYSTEMS.....	18
3.4. ANALYSING POWER SYSTEMS OF ISLANDS.....	20
3.5. POTENTIAL SOURCES OF FLEXIBILITY	22
3.5.1. Storage.....	23
3.5.2. Flexible generation.....	25
3.5.3. Flexible transmission and distribution grid	25
3.5.4. Demand-side management	25
3.5.5. Sector coupling.....	26
3.5.6. Flexibility of the energy market	26
3.5.7. Power system transformation.....	26
4. GIFT SOLUTIONS FOR FLEXIBILITY	27
4.1.1. Grid observability.....	28
4.1.2. Prevision and visualization of electricity demand and supply.....	29
4.1.3. Virtual Power plant System (VPS).....	29
4.1.4. Energy management system at harbour	29
4.1.5. Factory Energy Management System (FEMS).....	29
4.1.6. Electric Vehicles Charging stations	29
4.1.7. Storage technologies	30
5. LONG-TERM ENERGY PLANNING.....	30
5.1. OVERVIEW ON ENERGY PLANNING	31
5.2. LONG-TERM PROSPECTIVE MODELLING	31
5.2.1. TIMES Modelling approach.....	32
5.2.2. TIMES Model decision variables.....	35
5.2.3. TIMES Objective function	35
5.2.4. TIMES Model constraints.....	36
5.3. FLEXIBILITY IN LONG-TERM ENERGY MODELING	36
6. LONG-TERM DISCUSSION ON PROCIDA	38
6.1. DEMONSTRATION SITE: THE ITALIAN LIGHTHOUSE.....	38
6.1.1. Main territory aspects.....	38



6.1.2.	<i>GIFT Specific Objectives</i>	38
6.2.	THE ITALIAN ELECTRIC SYSTEM	38
6.2.1.	<i>Supply and demand</i>	38
6.2.2.	<i>The electricity markets</i>	39
6.2.3.	<i>The regulatory framework</i>	40
6.3.	MODELLING FRAMEWORK: TIMES-PROCIDA	42
6.3.1.	<i>Model horizon and tempo-spatial representation</i>	42
6.3.2.	<i>Base year energy system</i>	43
6.3.3.	<i>Evolution in time</i>	46
6.3.4.	<i>Scenarios</i>	50
6.4.	RESULTS.....	52
6.5.	DISCUSSION	59
7.	LONG-TERM DISCUSSION ON HINNOYA ISLAND CLUSTER.....	61
7.1.	DEMONSTRATION SITE: THE NORWEGIAN LIGHTHOUSE.....	61
7.1.1.	<i>Main territory aspects</i>	61
7.1.2.	<i>GIFT Specific objectives</i>	61
7.2.	THE NORWEGIAN ELECTRICAL SYSTEM.....	61
7.2.1.	<i>Energy production and consumption</i>	61
7.2.2.	<i>The Nordpool electricity market</i>	62
7.2.3.	<i>The regulatory framework</i>	64
7.3.	TIMES-HINNOYA MODEL DEVELOPMENT	68
7.3.1.	<i>Model horizon and tempo-spatial representation</i>	68
7.3.2.	<i>Base year energy system</i>	69
7.4.	DATA SOURCES AND ASSUMPTIONS.....	72
7.4.1.	<i>Demand and electricity prices evolution</i>	72
7.4.2.	<i>New technologies</i>	73
7.4.3.	<i>Scenarios</i>	79
7.5.	RESULTS.....	80
7.5.1.	<i>Final energy mix</i>	80
7.5.2.	<i>System cost</i>	81
7.5.3.	<i>Flexibility of the prosumers</i>	82
7.5.4.	<i>Fish farms alternative power solutions</i>	87
7.6.	DISCUSSION	87
8.	CONCLUSIONS & RECOMMENDATIONS.....	88
9.	ANNEX I: TIMES PROCIDA – TECHNICAL DEVELOPMENT	91
9.1.	MODEL DEVELOPMENT	91
9.1.1.	<i>General settings</i>	91
9.1.2.	<i>Time definition</i>	91
9.2.	BASE YEAR ENERGY SYSTEM.....	93
9.2.1.	<i>Demand side</i>	93
9.2.2.	<i>Supply side</i>	102
9.3.	ENERGY SYSTEM EVOLUTION	104
9.3.1.	<i>Demand projection</i>	104
9.3.2.	<i>New technologies</i>	104
9.4.	SCENARIOS DEFINITION	111
9.4.1.	<i>Annual photovoltaics investments</i>	111
9.4.2.	<i>Annual PV investments by sector</i>	112
9.4.3.	<i>Efficiency improvement</i>	112
9.4.4.	<i>Electric vehicles deployment</i>	113
9.4.5.	<i>V1G scenario</i>	113
9.5.	OTHER CONSTRAINTS DEFINITION	114
9.5.1.	<i>Max photovoltaics capacity constraints</i>	114
9.5.2.	<i>Max batteries capacity constraint</i>	117
9.5.3.	<i>Constraint on new batteries investments</i>	117
9.5.4.	<i>Smart Energy Hub investments</i>	117



10.	ANNEX II: TIMES-HINNOYA	118
10.1.	BASE YEAR ENERGY SYSTEM	118
10.1.1.	<i>Demand side – Load profiles</i>	118
10.2.	ENERGY SYSTEM EVOLUTION	122
10.2.1.	<i>New technologies</i>	122
11.	ANNEX III: TIMES MODELLING DETAILS	125
11.1.	THE CONSTRAINTS OF TIMES MODEL	125
11.1.1.	<i>Capacity transfer</i>	125
11.1.2.	<i>Link between activity and flow</i>	125
11.1.3.	<i>Capacity utilization</i>	125
11.1.4.	<i>Production/consumption balance</i>	126
11.1.5.	<i>Relationship between flows</i>	126
11.1.6.	<i>Limit values of flows</i>	127
11.1.7.	<i>Operational reserve</i>	127
11.1.8.	<i>Constraints on commodities</i>	128
11.1.9.	<i>User constraints</i>	128
11.2.	RESOLUTION OF THE MATHEMATICAL PROGRAM	128
11.2.1.	<i>The notion of duality</i>	128
11.2.2.	<i>The simplex algorithm</i>	129
11.3.	LINEAR PROGRAMMING IN INTEGER NUMBERS	130
11.3.1.	<i>Branch & Bound</i>	130
11.3.2.	<i>Cutting plane</i>	133
11.3.3.	<i>Branch & cut</i>	133
12.	REFERENCES	133

LIST OF FIGURES

Figure 1: Flexibility issues in a system with high penetration of solar photovoltaics (source: (IRENA, 2018a))	20
Figure 2 - Radial and meshed island grids (IRENA, 2018b)	21
Figure 3 - Diagram showing the synergies between variable renewable energies and energy system properties (IRENA, 2018b)	22
Figure 4 : Power system flexibility enablers in the energy sector (source: (IRENA, 2018a))	23
Figure 5: Range of services that can be provided by electricity storage (source: IRENA (IRENA, 2030))	24
Figure 6: Positioning of different electricity storage technologies according to their size and discharge time (source: IRENA (IRENA, 2030), based on US DOE/EPRI)	24
Figure 7: Innovations in the electricity supply chain (source: IRENA (IRENA, 2019))	27
Figure 8 - Diagram of the GIFT system architecture	28
Figure 9: Diagram of the flow battery	30
Figure 10: Example of Reference Energy System (source: (Richard Loulou et al., 2016))	33
Figure 11: Supply-demand equilibrium for a given commodity (based on (Richard Loulou et al., 2016))	34
Figure 12. Procida's location	38
Figure 13: Time structure used for the model	43
Figure 14: Estimated share of electricity consumption by end-use sector	44
Figure 15. Estimated electricity load fraction per time-slice at daily level in 2018	45



Figure 16. Procida's supply mix (on the left) and photovoltaics capacity share by sector (on the right) in 2018	45
Figure 17. Simplified scheme of the reference energy system	46
Figure 18. Comparison between Italian indexed GDP and electricity consumption trend (the reference year is 1987=100) (source: Terna, 2019 , based on Eurostat)	47
Figure 19. Scenario used to simulate the evolution of the electric cars share	49
Figure 20. Scenario used to simulate the evolution of the electric motorcycles share	50
Figure 21. Comparison between the average daily load by timeslice in 2018 and 2040	50
Figure 22. Max installable capacities constraint used to define the LOW and HIGH scenario	51
Figure 23. Total discounted system cost in the four investigated scenarios	52
Figure 24. Optimal investments on supply technologies in the four investigated scenarios	53
Figure 25. Optimal photovoltaics capacities evolution in the four investigated scenarios	54
Figure 26. Batteries capacity evolution over the time horizon (HIGH_STG and HIGH_STG_EFF scenarios)	55
Figure 27. Renewables share in end-use electricity consumptions for different scenarios	55
Figure 28. Renewables share in end-use electricity consumptions for supply sectors (HIGH scenario)	56
Figure 29. Electricity import evolution over the time horizon	57
Figure 30. Effect of storage on electricity imports at peak hours	58
Figure 31. Effect of storage on public buildings electricity imports	58
Figure 32. Comparison between the daily consumption share in the base case and V1G scenario (electric cars)	59
Figure 33 : Hinnøya's location	61
Figure 34 - Evolution of the electricity price for households in €/kWh (SSB, 2019)	64
Figure 35 - Temporal representation of the model (NTNU, 2020)	68
Figure 36 - Geographical representation of the model (NTNU, 2020)	69
Figure 37 – Energy mix of Hinnøya island cluster in 2015	69
Figure 38 - Electricity consumption by sector and region in 2015	70
Figure 39 – Share of electricity consumption of the fish farms in Grytøya	71
Figure 40 – Reference Energy System for TIMES-Hinnøya (Zhou W. and Assefa Hagos D. et al., 2020)	71
Figure 41 - Transport driver (Index 100 = 2015) - Harstad	73
Figure 42 - Transport driver (Index 100 = 2015) - Rest Hinnøya	73
Figure 43- Number of EVs sold in Harstad (based on HLK, 2020 GIFT D7.1)	75
Figure 44 - Energy supply of Hinnøya island cluster in 2050 (FLEX + ELSTR)	81
Figure 45 - Energy mix of Hinnøya island cluster in 2050 (HyWin + FLEX + ELSTR)	81
Figure 46 – Total discounted costs under different scenarios	82
Figure 47 – Schematic summarizing the EV charging strategies adapted from (Knezović, 2016)	83
Figure 48 - Charging BEVs with respect to electricity prices (Winter working day 2035)	83
Figure 49 - BEVs charging: repartition according to battery capacity	84
Figure 50 - Load demand profile and EV charging in 2035 (typical winter working day)	84



Figure 51 - Charging/discharging of BEVs (Summer Working day 2035)	85
Figure 52- Load demand profile and EV charging in 2035 (typical summer working day)	85
Figure 53 – E-Ferry binary charging	86
Figure 54 - Imports from NO4 to Harstad in TJ	86
Figure 55- Assumed New installation capacities of HBr storage in the three regions	86
Figure 56 - Fish farms electricity mix (2050)	87
Figure 57. Time horizon breakdown representation	91
Figure 58. Mean monthly solar irradiation value on an optimally oriented PV in Procida (source: PVGIS (JRC, 2019b))	92
Figure 59. Comparison between the annual average clear-sky solar irradiance and the residential load curve on a daily basis (normalization with respect to the peak irradiance value)	93
Figure 60. Italian typical residential load curve for a weekday and for different seasons (source: RSE (Maggiore et al., 2012))	94
Figure 61. Residential load curve for different model seasons	95
Figure 62. Seasonal load curve used for the tertiary sector (based on (GSE, 2019))	96
Figure 63. Annual load curve on daily basis used for the tertiary sector (based on Hayes et al., 2013)	97
Figure 64. Statistical distribution of the beginning of charge with respect to the battery state of charge	98
Figure 65. Charging time distribution	99
Figure 66. Charging capacity and current in percentage, as a function of the charging time	99
Figure 67. Battery state of charge at the end of charging depending on the state at the beginning of the charge	100
Figure 68. Consumption (in Wh) depending on the starting charge level and charging time	100
Figure 69: Number of days of use before loading	101
Figure 70. Number of bikes in circulation per month	101
Figure 71. Monthly consumption (in MWh) for electric bikes mobility	102
Figure 72. Monthly energy output from a fix-angle PV system in Procida(JRC, 2019b) (JRC, 2020b)	103
Figure 73. Schematic representation of the rSOC component of the Smart Energy Hub in TIMES	108
Figure 74: Evolution of photovoltaics installations in Italy (source: GSE, 2019)	112
Figure 75. Tertiary sector electricity load with and without efficiency policies	113
Figure 76. Example of roof surface estimation with PVWatts Calculator tool	115
Figure 77. Depth-first search with backtracking	133

LIST OF TABLES

Table 1 – Energy-related characteristics of an island with their indicators (Guerassimoff et al., 2008)	20
Table 2: Summary of the main decision variables used in TIMES (based on (Richard Loulou et al., 2016))....	35
Table 3 - Summary of the scenarios considered for the analysis.....	52
Table 4. Electricity prices for households in 2018 (ssb.no, 2019).....	63
Table 5 - Total energy demand in Hinnøya by energy source in 2015 (TJ).	70



Table 6 - The total national GDP growth forecast (index 100=2013).....	72
Table 7 - Annual transport service demand growth by transport mode. It shows the annual growth for both short and long-distance trips (Madslien et al., 2019)	72
Table 8 - Technical parameters for years 2020, 2030 and 2050 of the Battery Electric Vehicles.....	76
Table 9 - Charging stations technical parameters found in (NTNU, 2020).....	76
Table 10 – Technical parameters of ELESTOR flow battery	77
Table 11- Parameters and assumptions related to the ferry transport (NTNU, 2020)	78
Table 12- Emission values in kt/TJ based on IPCC 2006 (Guidelines for National Greenhouse Gas).....	79
Table 16. Summary of the input parameters for new PV installations	105
Table 17. Summary of the input parameters for new Li-ion battery installations.....	106
Table 18. Summary of technical characteristics of the Smart Energy Hub	107
Table 19. Summary of the input parameters for new seasonal storage installations	109
Table 20. Summary of the hypothesis made for the electric cars’ technical parameters	109
Table 21. Summary of the hypothesis made for the electric motorcycles’ technical parameters	110
Table 22. Summary of the values used to define the constraints on maximum annual PV investments.....	111
Table 23. Summary of the enterprises in Procida classified by building type.....	116
Table 24. Summary of the values used for the estimation of the total installable PV capacity in the tertiary sector.....	116
Table 25. Summary of the values used to define the max batteries capacity constraint.....	117
Table 26. Summary of the values used as maximum amount of new investments on batteries	117
Table 9 – Technical parameters of VREs technologies used in TIMES-Hinnøya.....	122
Table 13 – Parameters of Li-Ion system cost used in the TIMES-Hinnøya model (Danish Energy Agency, 2018b; European Commission. Joint Research Centre., 2018)	125

LIST OF ABBREVIATIONS

AFT	Afternoon
ARERA	Italian Regulatory Authority for Energy, Networks and Environment
BEV	Battery Electric Vehicle
BMS	Battery Management System
CAES	Compressed Air Energy Storage
CCGT	Combined Cycle Power Plant
CCS	Carbon Capture and Storage
CEA	French Alternative Energies and Atomic Energy Commission
CHP	Combined Heat and Power
CMA	Centre of Applied Mathematics
CO ₂	Carbon dioxide
DER	Distributed Energy Resources
DG	Directorate-General



DICI	Direct Injection and Compression Ignition
DSO	Distribution System Operators
EAFO	European Alternative Fuels Observatory
EASE	The European Association for Storage of Energy
EIA	Energy Information Administration
EMS	Energy Management System
EPRI	Electric Power Research Institute
ETS	Emission Trading Scheme
ETSAP	Energy Technology Systems Analysis Program
EU	European Union
EUR	Euro
EV	Electric Vehicle
EVC	Electric Vehicle Charger
EVE	Evening
EVE	Evening
FA	Flex Agent
FEMS	Factory Energy Management System
GDP	Gross domestic product
GFU	Grid Forming Unit
GHG	Greenhouse Gas
GIFT	Geographical Island Flexibility
GIS	Geographic Information System
GJ	Gegajoule
GME	Gestore Mercati Energetici
GSE	Georgian State Electrosystem
GSU	Grid Support Unit
GW	GegaWatt
H2020	Horizon 2020
HAFEN	Hafestrom
HFCV	Hydrogen Fuel Cell Vehicles
HLK	Hålogaland Kraft AS
HPDI	High-pressure direct injection
HPDI	High-pressure direct injection
ICE	Internal Combustion Engine
IEA	International Energy Agency
INEA	Innovation and Networks Executive Agency
IPCC	Intergovernmental Panel on Climate Change
IRENA	International Renewable Energy Agency



ISTAT	Istituto Nazionale di Statistica Liguria
JRC	Joint Research Centre
kWh	KiloWatt hour
LCOS	Levelized cost of Storage
LNG	Liquified Natural Gas
LP	Linear Programming
LPG	Liquified Petroleum Gas
MEP	Ministry of Petroleum and Energy
MEUR	Millions of Euros
MGO	Marine Gasoil
MID	Midday
MJ	Megajoule
MOR	Morning
MPG	Mercato del giorno prima
MSE	Ministry of Economic Development
MTE	Mercato elettrico a termine dell'energia elettrica
MW	MegaWatt
NGT	Night
NOK	Norwegian Krone
NOX	Nitrogen Oxides
NREL	National Renewable Energy Laboratory
NTM	National transport model of Norway
NTNU	Norwegian University of Science and Technology
NTP	National Transport Plan
NVE	Norwegian Water Resources and Energy Directorate
NWD	NonWeek Day
O&M	Operation and Maintenance
OCDE	Organisation for Economic Co-operation and Development
PAES	Piano d'Azione dell'Energia Sostenibile
PHEV	Plug-in hybrid electric vehicles
PIDF	Port Injection dual-fuel
PJ	Petajoule
PNIEC	The Integrated National Plan for Energy and Climate
PPA	Power Purchase Agreement
PV	Photovoltaic
RES	Reference Energy System
ROR	Run of River
rSOC	reversible Solid Oxide Fuel Cell



SIDS	Small Island Developing State
SNSP	System non-synchronous penetration
SRA	Scalability and Replicability Analysis
SSB	Norwegian statistics bureau
TIMES	The Integrated MARKAL-EFOM System
TSO	Transmission System operators
UN	United Nations
UNEP	United Nations Environment Programme
UNESCO	United Nations Educational, Scientific and Cultural Organization
UNFCCC	United Nations Framework Convention on Climate Change
US	United States
US DOE	United States Department of Energy
V1G	Grid to vehicle
VAT	Value-added tax
VPS	Virtual Power System
VRE	Variable Renewable Energy
WD	WeekDay

1. INTRODUCTION

1.1. BACKGROUND

Electricity is a fundamental and essential high-quality energy commodity that could and is being used in widespread day-to-day human activities. Its generation, transmission and distribution, and application are thus an important pillar of the energy system especially in developed countries. This includes the whole supply chain of resource extraction, energy conversion, and final energy delivery to end users.

Historically, electricity production has always been based on fossil fuels such as fuel oil, gas, coal and nuclear energy. However, these conventional methods of electricity production are major sources of GHG emissions that have strong global warming and air pollution environmental impacts. Also, fossil fuels are limited resources. To abate GHG emissions and ensure energy supply security, renewable energy sources have therefore become a viable alternative and are taking an increasingly prominent place in the global energy mix to satisfy the increasing global and regional electricity demand with a limited environmental impact (IEA and OCDE, 2018).

The intermittent nature of renewable energies combined with increasing demand requires grid operators to make an important and challenging operational and investment choices. Thus, in addition to the profitability and reliability of the system, they must also account for non-techno-economic issues such as environmental, social, and political constraints.

In the light of the opportunities and challenges of alternative energy sources, energy planning therefore plays a central role in providing a least-cost, environmentally friendly, and sustainable energy service to the society (Stoll and Garver, 1989). This is traditionally divided into a time dimension with short-term planning that corresponds to the satisfaction of daily demand, and long-term planning that focuses on the installation of new capacities or the implementation of new



technologies while minimizing the cost of the system. Indeed, the central idea is to determine the optimal energy production mix in order to satisfy the future demand while considering the technological developments and environmental, political and social constraints. In general, long-term energy planning aims to answer the following four main questions (Stoll and Garver, 1989):

- What type of energy technologies to choose?
- How much capacity should be installed?
- When should new capacities be installed and scrapped?
- Where to install new capacities?

Several of the islands in Europe are naturally endowed with various renewable energy sources, but due to technical, economic, and political issues only limited potential has been explored or harnessed in few islands. In fact, the islands' energy service structure is a bit different from that of the main land energy service structure and so is the energy system study. It needs to capture the future infrastructure developments, island specific energy policy issues, and spatial mapping of energy demand and energy sources (Guerassimoff et al., 2008). The penetration of renewable energies into the energy mix at island level cannot therefore be explored without developing island specific energy system models (Krakowski, 2016). This is because integration of VREs needs the deployment of relocation technologies such as storage, heat pumps, and fuel cells especially if there are no interconnections with the mainland grid. The lack of road infrastructure in some cases might even further increase the upfront investment costs of alternative energy sources in islands. Thus, although in many cases renewables are more profitable than conventional electricity production (KayserBril et al., 2008), the implementation of renewable solutions for energy production in islands is a complex problem at large.

1.2. ABOUT GIFT

GIFT (*Geographical Islands Flexibility*¹) is an innovative project, part of the H2020 research program of the European Union. It is a 4-years project started in 2019 whose main objective is to decarbonise the energy mix of European islands through the development of innovative solutions to allow the integration of vast amounts of renewables into the islands' energy system (electric, heating and transportation sectors).

The GIFT project focuses on two particular European islands, namely Hinnøya, Norway's largest island, and Procida, a small island in Italy; moreover, it is intended to study the possible replicability of the solutions in two other islands, Evia, in Greece, and Favignana, in Italy.

The project involves 17 European partners with different expertise and that is coordinated by INEA (Innovation and Networks Executive Agency²). The GIFT project has received funding from the European Union's Horizon 2020 research and innovation program (H2020)³.

The general ambition of the project is supported by the achievement of specific objectives, namely:

1. Allow a high level of local renewable energy sources penetration
2. Provide visibility to the energy grid to better manage its flexibility and plan its evolution
3. Develop synergies between the electricity, heating, cooling, water and, transport networks
4. Reduce the use of hydrocarbon-based energies
5. Ensure the sustainability of the solutions and their replicability in other islands

¹ <https://www.gift-h2020.eu/>

² <https://ec.europa.eu/inea/en>

³ <https://ec.europa.eu/programmes/horizon2020/en>



1.3. SCOPE OF THE DOCUMENT

The CMA, being part of the workgroup 2 of the GIFT project (*WP2: Pre-study and functional requirements*⁴), contributes to the development of this task. In particular, different possible evolutions of the energy system of the two demonstration sites are investigated through the implementation of energy-planning models, based on the MARKAL-TIMES (Market Allocation) model, a methodological corpus developed within the ETSAP (Energy Technology Systems Analysis Program⁵). The implementation of models presenting different scenarios will enable to discuss possible future trajectories of the energy system for the two demonstration sites (changes in supply, particularly for renewables, changing consumption, etc.). This will allow decision-makers to evaluate possible scenarios to increase the share of renewable energy sources and to better manage their resources. The results could be useful not only for the two islands considered in the analysis, but also potentially for other similar territories.

This methodology alongside the role it can play in the context of the project are thoroughly explained in chapter 5 of the present report.

2. INCREASING THE SHARE OF RENEWABLE ENERGY IN POWER SYSTEMS

2.1. GENERAL CONTEXT

The achievement of sustainability goals to tackle climate change is nowadays a major challenge in many different sectors. The energy field, that represents one of the most important contributions to CO₂ emissions due to its historical dependence on fossil fuels, is facing in this sense a real transition to decrease its environmental impact.

In such a context, the increase in the share of renewable energy sources in the production mix appears to be a valid solution. Indeed, other than presenting an enormous energy potential, these technologies can ensure energy production at low (or null) carbon emissions. Moreover, the current decrease of power generation costs is making renewable energy more and more attractive for public and private investors. This price drop is relevant especially when dealing with variable renewable energy (solar and wind), that represent today the most competitive renewable energy sources (IRENA, 2020a). In Europe, the spread of this type of technologies is furthermore supported by a favourable regulatory framework. Indeed, with the *Clean energy for all Europeans* package ambitious targets for renewable energy sources consumption are set (32% by 2030) (European Union, 2019).

However, the introduction of renewable technologies comes with important challenges, especially when dealing with electricity supply. Indeed, the management of this energy vector is much more difficult due to the hardly storable nature of electricity and intermittency of VRE sources. The electric grid should assure at all instant a balance between the production and demand. Nevertheless, as the electricity generated from some of the most commonly used renewable sources, namely solar PV and wind turbines, is dependent on external parameters such as weather conditions, the energy production from these technologies is strongly variable. Therefore, as the share of VRE sources increases, the necessity to ensure a reliable power system for the satisfaction of the electricity demand becomes more and more important.

The introduction of renewable energy could be much more relevant when dealing with islands. Indeed, these territories are often characterised by an over-dependency on fossil fuels and energy imports (European Commission, 2018), due to the additional geographical constraints (lack of mainland grid connection, limited installation space availability, the lack of access to road infrastructure). In these contexts, the management of VREs is much more relevant, as it could then give raise to the necessity of specific solutions to ensure the secure and cost-efficient operation of the energy system (EASE, 2020). Nonetheless, the challenges faced by islands could represent a valuable example for interconnected energy

⁴ Before in *WP3: Modelling, assessing and forecasting of energy system*

⁵ <https://iea-etsap.org/>



systems, which will have to tackle the challenges of integrating high shares of variable renewables in the coming decades (EASE, 2020).

2.2. RATIONALE FOR ISLANDS

Islands face many challenges when it comes to energy supply and security and economic development. Owing to their small size, islands constitute a marginal market for international suppliers of energy and energy services, and they are often not able to obtain beneficial prices from bulk purchases. In addition, their remoteness implies high transportation costs. Moreover, islands are among the first victims of climate change: consequences for small islands vary from property damage to rising sea levels and coastal erosion.

Naturally, islands would consider investing in sustainable energy solutions like developing domestic renewable energy within their territory. These actions would fit in a long-term strategy to ensure their autonomy and enhance their resilience. In that way, they also demonstrate their commitments to the strategies and policies set by the national authority (in case they are not independent States) and to the international climate conventions such as the Paris Agreement, and finally to set the example for reducing CO₂ emissions, that they want for industrialized countries to follow. (Guerassimoff et al., 2008; Oestergaard, s. d.)

Due to their small size and their limited energy consumption, islands have historically relied on thermal generators based on fossil fuel. Although these options seemed adequate for islands to ease the geographical constraints including the possible lack of electric connection to the continent, limits in the space available for the installation of supply technologies, the lack of road facilities, islands found themselves facing increasing challenges of over-dependency to fossil fuels imports (European Commission, 2017). Furthermore, these conventional solutions are reasons of noise and air pollution, as well as degradation of natural resources on these territories especially in case of oil spillage during transportation and storage.

In this sense, achieving a real energy transition on islands became a main pillar to address the economic, environmental and geographical challenges. The increase in the share of renewable energy sources in the production mix appears to be a valid solution. These technologies can ensure energy production at low (or null) carbon emissions and are suitable for territories endowed with renewable energy potential. Moreover, the current decrease of power generation costs is making renewable energy more and more attractive for public and private investors. This price drop is relevant especially when dealing with solar and wind energy, which represent today the most competitive renewable energy sources (IRENA, 2019).

2.2.1. Decarbonization

Decarbonizing the energy system goes along climate change mitigation actions. In fact, several studies on national or regional levels tackle this issue according to the targets set for reducing the greenhouse gas (GHG) emissions that can be found in the Nationally Determined Contribution (NDCs) elaborated under the Paris Agreement (UNFCCC, 2015), or local and regional policies.

In (Rakotoson & Praene, 2017) the decarbonization of the energy system is addressed through an optimization approach based on linear programming. The elaboration of the long-term energy planning aims towards reaching low GHG emissions of the Reunion Island, France. The objective of the study is to determine an optimal generation mix that minimizes greenhouse gas (GHG) emission, by quantifying the expected cost of the emissions of the proposed system. The main constraints considered are the evolution of the electricity emission factor limited by the targets set by the government and energy security in terms of meeting the demand.

In the framework of GIFT project, the long-term prospective modelling of the island Procida in Italy addresses the decarbonization of the energy system by integrating renewable energy, mainly photovoltaics in the residential, tertiary and public sectors. The island relies mostly on import of electricity from the mainland and that the decarbonisation prospective with installation of PV concerns the demand side. This was quantified in the model as a share of renewable energy in the end-use electricity consumption on the



island level and on a sectoral basis. In (Zhou W. and Assefa Hagos D. et al., 2020) deep decarbonization of Hinnøya's whole energy system is studied. This was done through soft-linking of long-term planning model, TIMES-Hinnøya, and economic dispatch model, EnergyPLAN-Hinnøya. The foundation of their analysis included an evaluation of the emissions pathways under the national current low-carbon policies and the future and more stringent policies like the ban on new diesel/gasoline cars or carbon tax.

2.2.2. Energy Autonomy

In its broad sense, autonomy relates to the notion of self-governance or independence. It can be defined as "freedom of external control or influence". As for energy autonomy, it is defined as the ability of the energy system to function (or have the ability to function) fully without the need of external support like imports. The system should rely on its own local capacities in terms of generation, capacities and distribution systems (Ray & Bradley, 2012).

Energy autonomy concerns islands as they are often dependent on imports of energy commodities: electricity given that they are connected by marine cables, fuel to activate diesel generators and power the transportation fleet. These options are also be utilized by islands when the demand is exceeding the supply or as backup to deal with grid balancing.

Furthermore, energy autonomy has been linked to the potential to reduce the cost of energy, and the ability to significantly reduce the carbon emissions associated with a community or region (Drouineau et al., 2015; Ray & Bradley, 2012). As such, achieving these targets promotes the integration of variable renewable energy such as wind and solar in the energy system.

In (Selosse et al., 2018), energy autonomy through large-scale integration of renewable energy of the Reunion island - an isolated island of the French territory- was evaluated through the prospective analysis of the electricity system. The analysis, developed with TIMES-Reunion, considers the additional cost of electricity incurred to the system and the reliability consideration of the system. The territory is endowed with several renewable energy resources and was historically reliant on hydroelectricity for power supply. Other high potential renewable resources on the island include solar and wind power, biomass, marine and ocean energy, and geothermal energy. Nevertheless, their potential is not fully exploited. For instance, wind power exploitation is limited due to harsh weather conditions requiring types of technologies with high costs. As for geothermal, its potential location coincides with an environmentally protected area. In addition, the increasing demographic and economic growth reduces energy self-sufficiency where the island's energy mix is still dominated by fossil primary energy. The result of the analysis shows the influence of energy policy instruments on the choice of renewable energy technology deployment. Moreover, the economic and political support and social acceptability can be detrimental for transitioning to 100% renewable energy transition; that participates in the energy autonomy of an island and can alter the choice of technologies and incur additional costs.

2.2.3. Exploitation of local resources

Many islands are endowed with renewable energy potential and achieving energy autonomy and decarbonization of energy systems of islands are intrinsically accelerated with the integration of renewable energy in the energy systems. However, their exploitation depends on geographical constraints as well as the economic development of the respective island (Guerassimoff et al., 2008). Furthermore, the transition to systems that solely rely on exploitation of renewable energy requires additional investments. In fact, this transition often depends on the coupling of renewable energy technologies with storage, demand side management, and development of smart microgrids (Katsaprakakis et al., 2019; Marcinkowski et al., 2019).

In (Katsaprakakis et al., 2019) a 100% renewable energy system for Faroe Islands, Finland is studied. Their approach was based on a technical feasibility and economic evaluation of the electricity prices regarding the implementation of a hybrid power plant combining wind power and pumped hydro storage for insular systems. The islands' topology, wind potential and energy demand were the subject of the study. Moreover, the dimensioning of reservoir expansion was done through on-site geotechnical-assessment. Such evaluation necessitates a thorough understanding of the territory for harnessing the potential of the



present renewable energy resources. It was shown that studying the potential of renewable energy as primary energy sources is quite important for technology choice, as the hydro-storage never reaches its maximum capacity during summer (during low wind potential) and thus did not participate in the transition to a 100% renewable energy system.

Optimizing the cost of the whole energy system is a common objective when planning the energy system (see 5.1), especially for territories that are still in development. This is the case of Antigua and Barbuda which is a Small Island Developing State (SIDS) (UNESCO, s. d.). Antigua and Barbuda form together an island nation consisting of two land masses separated by 43 kilometres in the West Indies in the Americas, lying between the Caribbean Sea and the Atlantic Ocean, situated at close to fifty meters to the north of Guadeloupe. With the support of the International Renewable Energy Agency (IRENA), a roadmap for 100% renewable energy integration was developed with different scenarios, including electric vehicles and green hydrogen. The least-cost based on net-present cost is the optimal scenario which still relies on the diesel generator at 6% of the total electricity generation by 2030 (IRENA, 2021).

3. FLEXIBILITY OF POWER SYSTEMS

3.1. GRID STABILITY AND THE FLEXIBILITY OF POWER SYSTEMS

Grid stability is key for the proper functioning of the electrical energy system at any instant, and there must be a balance between production and consumption at all times in the grid that maintains the voltage and frequency within the limit. This therefore implies the implementation of a robust and dynamic power system network capable of interacting with the whole energy system.

A reliable electricity system requires a production mix capable of responding to constant variations in demand and to provide an operational reserve in cases of unforeseen extreme weather events, scheduled maintenance periods, system outage, and unforeseen peak electric demand periods. Thus, in addition to being able to satisfy the predicted demand, it is required to have additional reserve capacity in all kinds of contingencies. This balance between supply and demand at all times is crucial since a small failure can totally unbalance the system, particularly the frequency adjustment closely linked to consumption and production (Krakowski, 2016).

The majority of European countries aim to provide electricity with low carbon intensity sources, and this could be achieved mainly through three main channels (Denholm and Hand, 2011):

- Nuclear production.
- Production from fossil fuels but with carbon capture and storage (CCS) systems.
- Production from renewable energy sources.

But any of the states have opted for the integration of renewable energies, which are expected to play a major role by 2050 (IEA and OCDE, 2018).

Renewable energy sources are mainly classified as dispatchable (such as reservoir hydro, geothermal, and biomass-based combined heat and power (CHP) plants) and non-dispatchable or use it or lose it energy sources (such as wind, solar, and run-of-the river (ROR) hydro power plants). These are characterized by the notion of variability in their production patterns, lack of load following capability, and present their own technological difficulties (Kondziella and Bruckner, 2016):

- Production is variable since it is determined by weather conditions and rarely correlated with consumption



- It is uncertain and difficult to predict (the forecast error making it difficult to schedule reserve capacity in a day-ahead electricity market).
- It is a decentralized energy source with multiple small and modular installations.

As the penetration of VREs into the traditional electricity system grows, the need for supply- and demand side flexibility in the power grid and energy system at large becomes inevitable. In (Huber et al., 2014) it was showed that a 30% market penetration of VREs (wind and solar) would jeopardise the reliability of the grid system. As the share of VRE sources increases, the operations of the power system become increasingly variable and uncertain, resulting in a threat for the reliability of electricity supply. In this context, the concept of flexibility becomes extremely relevant.

System flexibility, in electrical energy system context, can be described as the ability of an electrical system, including generators, to sufficiently respond to changes in production and/or demand without jeopardising the grid stability (Cochran et al., 2014). There is an interest to share the burden of the grid flexibility with the whole energy system and explore potential synergy effects across energy subsectors.

In (IEA, 2019), we find a techno-economic definition of flexibility, it is defined as: *“the ability of a power system to reliably and cost-effectively manage the variability and uncertainty of demand and supply across all relevant timescales, from ensuring instantaneous stability of the power system to supporting long-term security of supply”*. Flexibility describes the degree to which a power system can adjust the electricity demand or generation in reaction to both anticipated and unanticipated variability. It also indicates the capacity of a power system network to reliably sustain supply during transient and large imbalances (Babatunde et al., 2020).

Thus, energy systems have a natural need for flexibility to meet changing demand over time and to equalize supply and demand. Traditionally, flexibility on the grid originates from the production side by ramping up and down conventional dispatchable power plants in line with fluctuations in demand. This is referred to as supply-side adjustment. Hourly flexibility is achieved by varying the generated power and calling additional power plants if necessary. Nevertheless, to provide auxiliary services and/or play a primary and secondary reserve role, storage technologies are the most suitable technologies.

3.2. FLEXIBILITY AND RENEWABLE ENERGY INTEGRATION IN THE POWER SYSTEM

In a power system with high share of VREs, the most relevant parameter to look into is the net power demand, i.e. the difference between the power demand and the renewable production. As VREs are a use it or lose it energy sources, the net power demand would be covered by dispatchable or load following power plants including reservoir hydropower plants (Denholm and Hand, 2011).

The flexibility of the system is closely linked to the capacity of the base power plants and those constituting the operational reserve to increase or decrease their production in line with the net power demand (ibid.).

However, traditional electrical systems were not initially designed to accommodate VREs and are essentially composed of base power plants capable of high production at low marginal cost. Nevertheless, with high number of start-and-stop cycles, production gradients, and high thermal stress the traditional base power plants are unsuitable for a system with high share of VREs (IRENA, 2018).

The increased cost competitiveness of VREs due to technological advancement, economies of scale, and various incentives to promote renewable energy production has contributed to the modest share of VREs in most advanced energy systems in Europe. Nevertheless, in a deregulated electricity market such as Nordpool, the risk of overproduction is increased during periods of high VREs production if the thermal power plants are not able to drastically reduce their production, sometimes leading to low or even negative prices on the market to restore balance. The presence of negative prices on the market is then a good indicator of a system's lack of flexibility (IRENA, 2018).



Thus, the flexibility of an electricity system depends strongly on its technology mix, a system essentially composed of reservoir hydropower and gas turbine will be more flexible than a system composed of nuclear or coal-fired power plants.

In addition, this variation between production and consumption threatens the reliability of the system and its inertia or its ability to regain its voltage and frequency stability shortly after disturbance. Thus, the lower the inertia of the system, the faster the frequency change and the more difficult it is to maintain its reliability.

It is of relevance to look at the impact of the introduction of renewables in the electricity system in a chronological way (Alizadeh et al., 2016): (1) in the short term, it implies an increase in the need for load following production units, an increase in the need for reserve capacity, and limit the penetration of VREs so as to avoid wind turbine curtailment, (2) In the medium term, since thermal production units are required to regularly vary their production or even have to be restarted, their components are degraded more quickly and this leads to higher operating and maintenance costs in parallel with lower incomes when they are not scheduled for production and (3) In the long term, investments may focus mainly on low-emission technologies (nuclear, geothermal) or carbon capture and storage systems that have limited flexibility and will therefore reduce the overall flexibility of the system. This is reinforced by the introduction of renewables, which are also encouraged to limit emissions and on which investments are also made. Thus, these units, which are not very flexible in base, could only rarely be called and therefore often switched off, limiting the return on investment. Thus, units with better response times should develop in base but with higher marginal costs.

It is fairly reasonable to assume an electric energy system as a flexible system if it does satisfy the following points (Cochran et al., 2014):

- Maintaining the supply-demand balance.
- Meet peak demand and net power demand.
- Ensure the availability of units with production gradients capable of responding to the variability of renewables
- Have storage capacity to allow balancing (Mohler and Sowder, 2014).
- Be able to adjust demand (Demand Side Management) (Lund et al., 2015).
- To have efficient auxiliary services (reserve capacity, erasure capacity, etc.) (Lund et al., 2015).
- Operate in a market that allows flexibility (Lund et al., 2015).

Thus, there is a wide variety of solutions to meet the challenge of integrating renewables. The optimal choice of these solutions must be made considering the associated costs and the characteristics of the network on which they are to be integrated (Kondziella and Bruckner, 2016). In addition, in the case of islands, electricity systems face different and more complex constraints than traditional systems when it comes to integrating intermittent renewable energies (Drouineau, 2012; Tsuchida, 2014).

3.3. TECHNICAL ASPECTS OF INTEGRATING RENEWABLE ENERGY IN POWER SYSTEMS

From the technical point of view, a variation in the assets' generation or in the load determines a variation in the frequency of the transmission system. To ensure the system stability and thus the reliability of supply, Transmission System Operators (TSO) have to maintain this parameter at a certain level (50 Hz in Europe). In power systems with low shares of VREs, the system stability is ensured by the inertia provided by thermal generators with advanced cycling capabilities (e. g., open-cycle gas turbines, hydropower plants and pumped hydro storage)(IRENA, 2018a). Indeed, these generation units produce synchronous power



and can provide inertia as they are directly connected to the grid. On the other hand, VRE sources such as wind and photovoltaics are said to be non-synchronous, as they do not have a direct electro-mechanical coupling to the grid, and cannot provide inertia (IEA, 2020). Increasing the inertia determines a decrease in the rate of change of frequency in the grid, that in turn allows the system to instantaneously recover from imbalances in supply and demand (IRENA, 2018a).

In practical terms, the synchronous inertia is the energy stored in the rotating masses of generators that are mechanically synchronised to the grid (EASE, 2020). The inertia properties of a synchronised generator can be used as a shock absorber for network stability, giving system operators time to take proper measures to restore the balance, also known as ancillary services (synchronised regulation, contingency reserves, black-start regulation, flexibility reserves (Greening the Grid, 2014). In general, if the inertia of the system is too low the frequency response mechanisms do not manage to arrest the frequency decay in time, resulting in load shedding or even blackouts (EASE, 2020). Every power system should then satisfy specific requirements for the inertia of the system that consist in having some synchronous capacity that is dispatched at all times. Among them, one of the reliability measures used by TSOs is the definition of a maximum limit of non-synchronous generation, also called system non-synchronous penetration (SNSP). As a consequence, reaching high shares of VRE in a power system can become very challenging.

Additionally, the increase in the share of VRE has important consequences on the dynamic stability of the power system. This is due to the fact that the power flowing into the grid affects the voltage of the system; during high load periods the voltage decreases, whereas during low load periods the voltage increases. In general, the reactive power capacities are used to control the voltage in the grid. At this aim, the TSO has to ensure at all instant the balance between the injection and absorption of reactive power to keep the voltage at a reference level (EASE, 2020). As for the inertia, the reactive power is provided by conventional units.

Flexibility has always been an important requirement in energy planning, as the power system has to ensure the supply reliability even during unexpected contingencies (e.g. the outage of a major supply unit). Historically, this requirement was fulfilled by introducing a reserve margin in capacity; defined as the difference between the installed supply capacity and the peak load. However, the increase in the uncertainty in the net load (defined as the difference between the electricity demand and the generation from VRE) due to the increase in VRE sources could lead to difficulties to reliably predict resource availability of VRE and thus size and schedule the operation of spinning reserves, resulting in high fuel and availability costs (IEA, 2020).

Moreover, synchronous generators are subjected to technical constraints (such as constraints on operational levels and ramp up constraints) that limit their capability to cope with the intermittency of renewable sources. When synchronous generators are unable to balance the load variations, the power system might experience two different conditions, that are the VRE curtailment and the loss of load. The first one occurs in overgeneration or inertia shortage conditions, when the electricity production from flexible sources cannot be backed down further to accommodate VRE supply. In this case the TSO decreases the variable sources generation to maintain frequency and voltage at their nominal values. For wind turbines this is made by changing the blade pitch angle, whereas in the case of solar photovoltaics by reducing the output from the inverter or by disconnecting the plant (Denholm et al., 2015). The loss of load instead occurs when the power system supply is unable to cover the electricity demand. This can occur for example when the upward ramping of synchronous generators is not fast enough to instantaneously balance the load. This is the most severe condition, as it results in supply reliability issues.

An example of the two conditions in the case of high penetration of solar photovoltaics is shown in Figure 1. In general, the flexibility of a power system with high shares of VRE can be assessed by looking at the occurrence of curtailments and losses of load. Another indicator could be the electricity price, as it decreases (reaching in some cases negative prices) when the oversupplies occur, but also price volatility (Cochran et al., 2014).

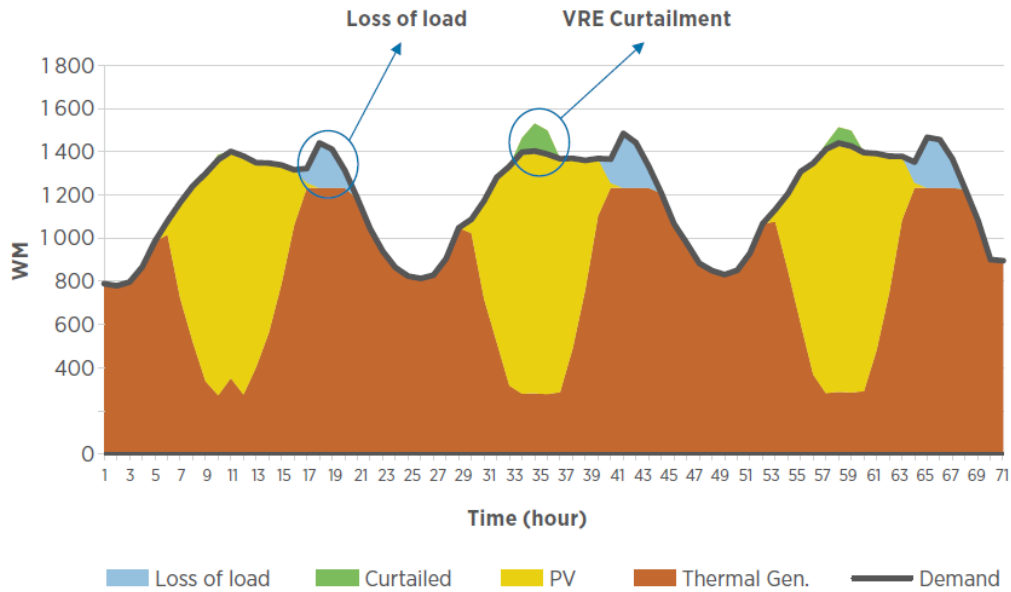

Figure 1: Flexibility issues in a system with high penetration of solar photovoltaics (source: (IRENA, 2018a))

Finally, it should also be considered that variability in the operation of synchronous generators flexible sources determines an overall lower energy efficiency (de Groot et al., 2017) and it has implications on the profitability of these plants, because the decrease in the frequency of dispatch and in the generating hours could lead to insufficient revenues on the energy market. This phenomenon is relevant especially for synchronous generators such as nuclear units, geothermal, and carbon capture and sequestration, towards which the most important investments are expected in future years to comply with environmental constraints. Indeed, given their limited flexibility in the operations (due to high minimum generation amount and low ramp capability), the rate of return for these plants will be much lower. Thermal power plants that can provide a fast response, such as CCGT, will then be more frequently deployed despite their higher energy price (Akrami et al., 2019). High shares of variable renewables in the electricity grid could therefore make the power system inefficient and expensive.

3.4. ANALYSING POWER SYSTEMS OF ISLANDS

The analysis of energy systems of islands includes both a classical analysis of the energy system as well as considering specific parameters of islands. Classical analysis is described in (Guerassimoff et al., 2008); it involves acquiring data on GDP, demographic, primary energy consumption, CO₂ emissions, renewable share in the electricity mix as well as total fossil energy reserves. Based on a principal component analysis it was shown that the island situation and the energy dimension are two almost independent dimensions. However, it was systematically proposed to compare these dimensions through a graphical representation and based on the three themes: Energy resource, Energy profile and Energy management, the island situation represented by an index for which the calculation is explained in the first chapter of the book. The characterization of the island energy problem from data on 70 islands takes the form of three graphs where the islands considered are represented by points. For example, if the energy profile of an island is the characteristic of interest, a calculation of the relevant indicators with the index of the island situation would allow us to place this island in comparison to the studied islands.

Table 1 – Energy-related characteristics of an island with their indicators (Guerassimoff et al., 2008)

Energy-related characteristic of an Island	Indicators
Energy resource	Energy independence rate

	(Production/Consumption primary energy)
	Fossil fuel reserves
Energy profile	Primary energy consumption (tep/hab)
	Share of REN and hydro in energy production mix
Energy Management	Energy Intensity (tep/k\$PPA)
	Carbon Intensity (tCO ₂ /k\$PPA)

Another aspect that is gaining concern with the integration of renewable energy is the reliability of the power system. Due to the intermittent nature of the renewable sources, the reliability of the power system of islands can be impacted. In fact, the reliability of an island power supply system can be weak. For example, (Drouineau et al., 2015) have compared the reliability of the power supply of the Reunion island to Metropolitan France. It was shown that the average duration of loss of load or electricity not supplied on the island is three times more than that of the mainland at the time the study was conducted.

As a first approach to study the reliability of the power supply, the islands' energy systems can be evaluated depending on the strength of the grid and its structure. According to (IRENA, 2018b), network strength plays a fundamental role in the integration of VRE and a **weak grid** is characterised by a radial network as seen in the figure 1. A weak grid also has high electrical distances between generating units and between generating units and loads, and introduces several constraints for the integration of VRE. Weak grids usually present low transient stability margins and high voltage sensitivity with respect to load fluctuations.

A **strong grid**, on the other hand, is characterised by a highly meshed system with shorter electrical distances between generating units and loads. These grids usually are much more robust in terms of transient stability, and present lower sensitivity of voltages with respect to load variations.

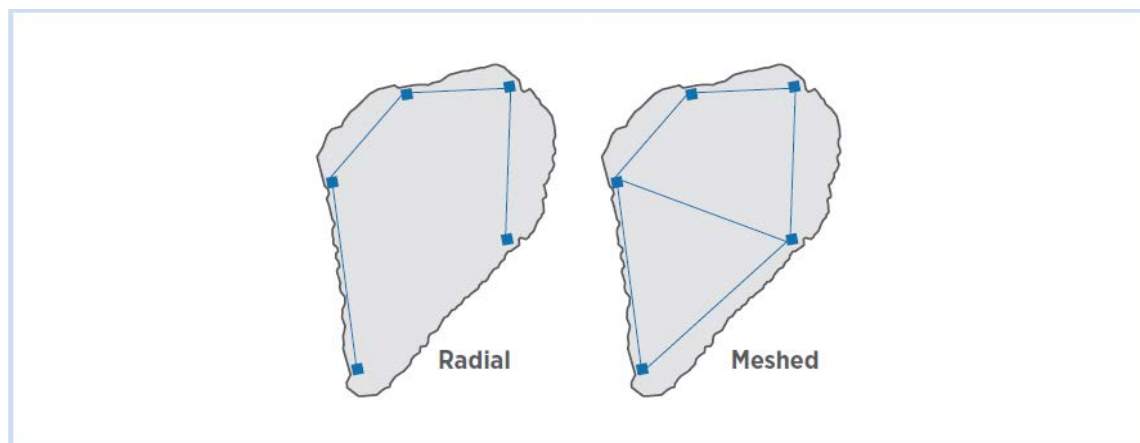

Figure 2 - Radial and meshed island grids (IRENA, 2018b)

The diagram below summarizes the VREs properties discussed earlier and their impact of the flexibility of the power system due to their stochastic nature and inherent intermittency. These features of VREs pose threats in meeting the energy demand and maintaining power system stability- voltage and frequency regulation.

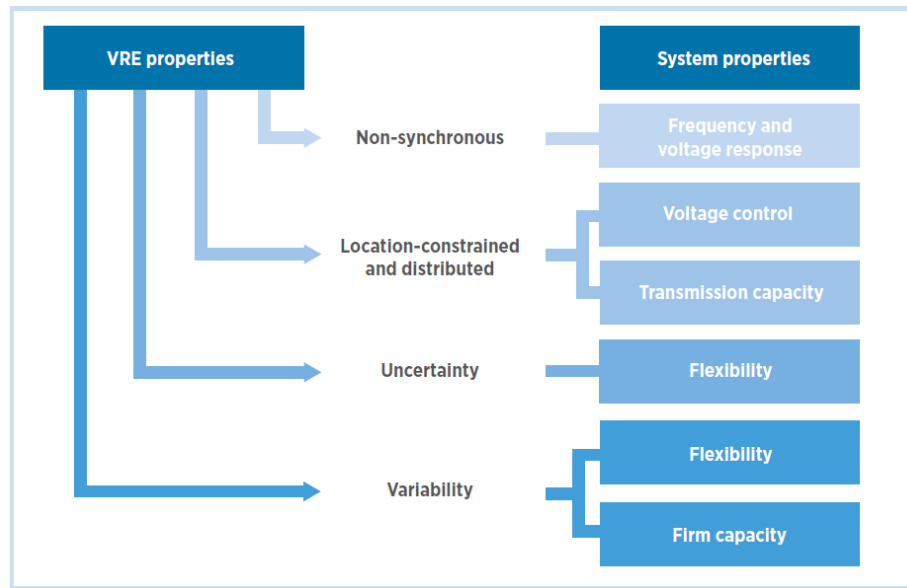

Figure 3 - Diagram showing the synergies between variable renewable energies and energy system properties (IRENA, 2018b)

With the uncertainty of VREs, production levels present deviations from the forecasted or expected levels. This highly impacts the challenges related to the stability, followed by generation adequacy, intraday flexibility and static thermal/voltage grid limits. In case of lack of flexibility in a system, there is a need to recourse to generation curtailment (mainly VRE curtailment) or load shedding in order to restore load and generation balance (IRENA, 2018b, 2021).

3.5. POTENTIAL SOURCES OF FLEXIBILITY

There are several well-proven supply and demand side flexibility measures that can be used to introduce a better flexibility into the traditional energy system: (1) institutional changes (policies), (2) the adaptation of operational methods and of the production mix (Adaptation to demand), and (3) storage, demand management, the introduction of a more flexible generation system, as well as many other mechanisms suitable to each situation are some to mention. In this section we further elaborate and present some of the aforementioned solutions.

It results that conventional flexibility sources alone cannot address this ever-growing need of flexibility. As the variability of VREs occurs at different timescales (seconds to years), different flexibility requirements should be addressed to ensure the reliability of supply. Different solutions, that cover all the constitutive parts of the energy system, should then be introduced. These could involve power generation to stronger transmission and distribution systems, electrical and thermal storage and demand-side management (cf. Figure 4) (IRENA, 2018a).

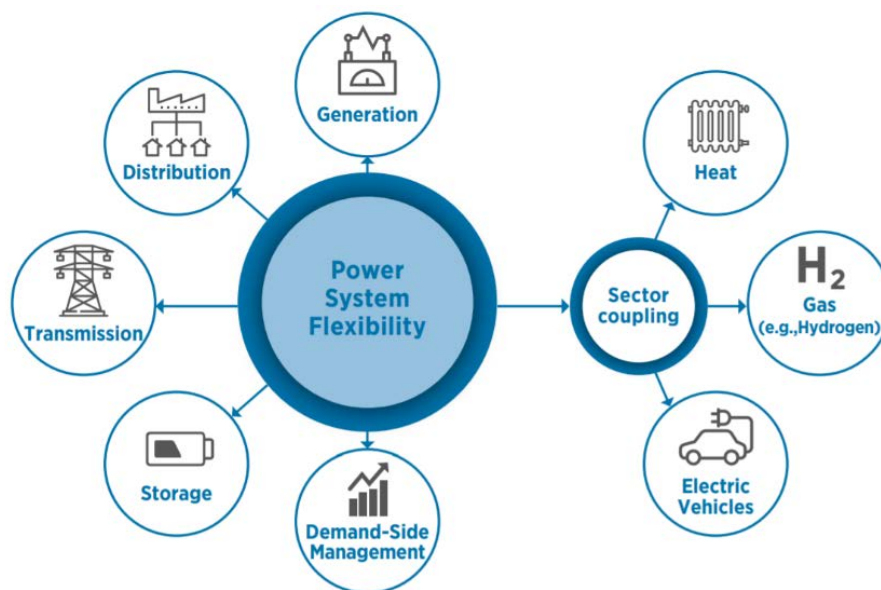

Figure 4 : Power system flexibility enablers in the energy sector (source: (IRENA, 2018a))

The combination of these solutions can lead to the increase of the overall system flexibility.

3.5.1. Storage

Electricity storage refers to technologies that store electrical energy and release it on demand when it is most needed through the conversion of electricity to other forms of energy and back again (IRENA, 2020b). Given their valuable potential contribution to the grid management, these technologies are considered a prominent solution to integrate large amounts of VREs in power systems.

The electricity storage can be installed at any level of the energy system: at the transmission or distribution grid, coupled with other generation facilities or used in behind-the meter applications (i.e. used by final consumers). According to its location and operational mode, the regulatory framework and the market, it can provide several different services to the grid (IRENA, 2020b). For example, if used at transmission or distribution level it can provide grid services (such as ancillary services or distribution network support), whereas if coupled with supply technologies it can provide bulk energy services (it can for example shift the electricity production of VREs to non-production times, supporting the integration of these sources in the electricity grid). It can also be used by final consumers for energy management services (i.e. self-consumption, that improves the bill management, power quality and reliability, other than supporting the deployment of VREs at distribution level). Electric batteries can also be used for electric vehicles in the transportation sector.

A summary of all the services that storage systems can provide to the energy system is shown in Figure 5.

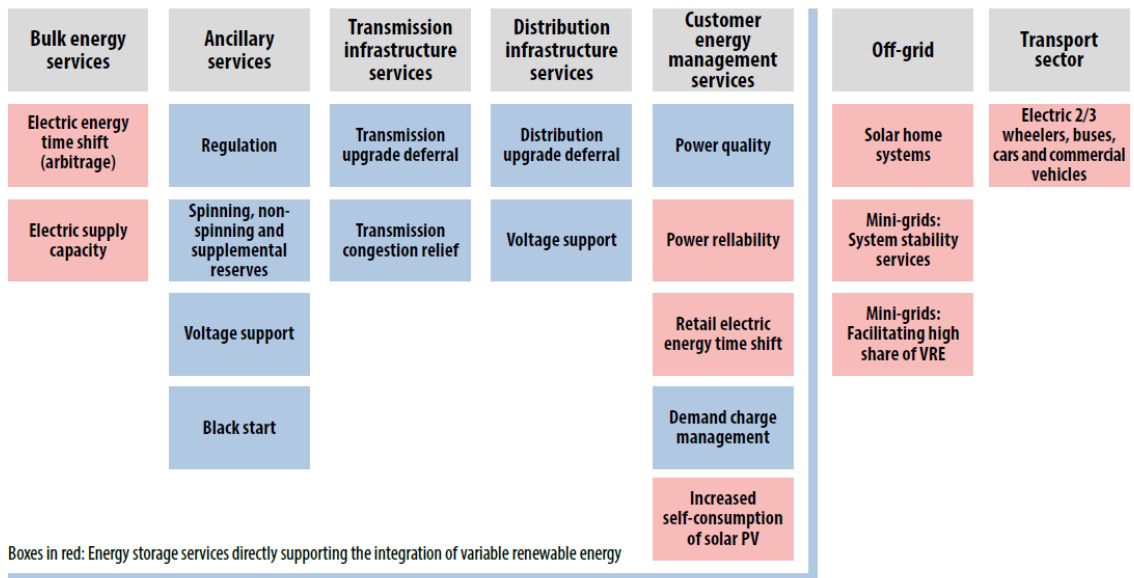
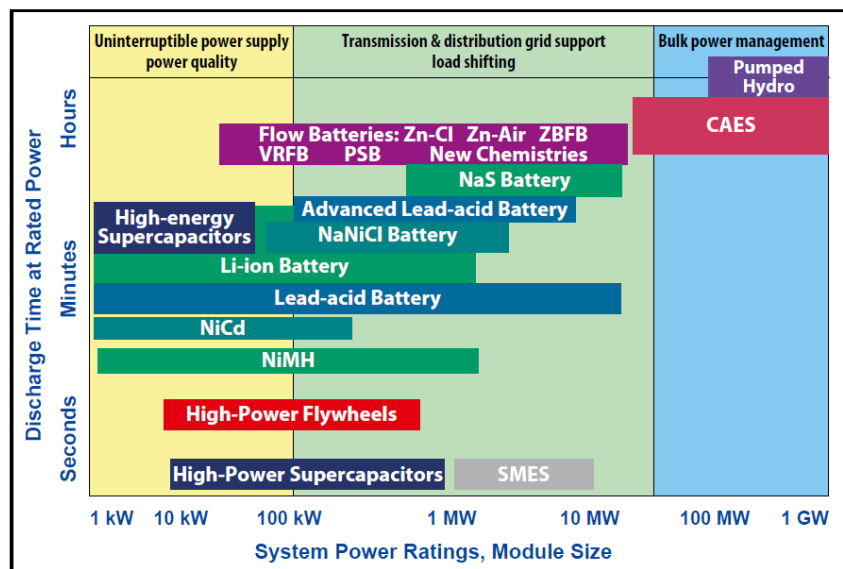

Figure 5: Range of services that can be provided by electricity storage (source: IRENA (IRENA, 2030))

There exist a large variety of different storage technologies, such as pumped hydro, solid batteries, flow batteries, flywheels and compressed air energy storage (CAES). Currently, pumped hydro is the more mature and most exploited one. However, the recent costs decrease of Li-ion batteries is making this technology a widespread one.

Each storage technology presents some specific features that make the technology suitable for specific applications. In particular, useful parameters to evaluate the suitability of a technology are the response time, the system size and the discharge time. As an example, the most suitable applications of a storage can be determined according to the system size and discharge time (cf. Figure 6).



Source: US DOE/EPRI, 2015.
 Note: Zn-Cl = zinc chlorine flow battery; Zn-Air = zinc air flow battery; ZBFB = zinc bromine flow battery; VRFB = vanadium redox flow battery; PSB= polysulfide bromine flow battery; NaS = sodium sulphur; NaNiCl = sodium nickel chloride; NiCd = nickel cadmium; NiMH = nickel-metal hydride; SMES = superconducting magnetic energy storage.

Figure 6: Positioning of different electricity storage technologies according to their size and discharge time (source: IRENA (IRENA, 2030), based on US DOE/EPRI)

Regarding flexibility requirements to ensure the reliability of supply, batteries have significant potential for providing short-term flexibility services, such as providing multiple ancillary services to the grid and



supporting self-consumption. Concerning long-term flexibility issues instead, such as seasonal imbalances in VRE production, other technologies may be used. In particular, one of the most relevant ones is pumped hydro storage, due to the maturity of the technology and the competitiveness of costs. However, this solution could not be feasible when dimensions constraints are important. In these cases, new technologies such as “power-to-X” where X refers to gas, hydrogen, heat, or synthetic fuels are emerging. For example, at high VREs share, storing hydrogen exploiting the electrolysis process could result as a valid solution to seasonally shift the electricity production. These devices could contribute the electrification of sectors that are otherwise difficult to decarbonise; nevertheless, at the current state of development these technologies are not cost-effective(IEA, 2019).

3.5.2. Flexible generation

The flexible generation refers to the ramping ability of power assets to match supply and demand quickly and efficiently and run at low power output levels (Cochran et al., 2014). This practice is typically provided by conventional power plants; however, the flexibility requirements become more and more strict as the share of VRE increases.

In this context, a viable solution could be the improvement of the operation of existing supply sources, to increase their ability to rapidly change plant output, to start and stop more quickly, to turn plant output down to lower levels avoiding shutdown risks(IEA, 2019). In the practice, this could be made either by equipping power plants with enhanced technologies or by improving their operational practices (Greening the Grid, 2014) . The first one could consist for example in the coupling of existing units with battery storage technologies. The improvement of operational practices instead could be easily implemented by improving data collection and real-time monitoring (IEA, 2019).

3.5.3. Flexible transmission and distribution grid

Grid flexibility refers to the capability of an electricity grid to efficiently and cost-effectively balance supply and demand in real time ensuring the reliability of supply even in case of high shares of VRE sources.

Both at transmission and distribution level, different options are available to improve the flexibility of the grid. In some cases, the most relevant solution is the reinforcement of the grid. However, this procedure is often avoided due to the high investment costs and the long time it could take. An easier solution to enhance the flexibility of the grid could be the improvement of grid operations, for example by introducing solutions to make the communication among system elements more efficient. This could be made by automating the control of generators, the demand response activation or the control of power flows(IRENA, 2018a). Additional solutions could include the introduction of market-based flexibility instruments and improved market designs. Both the system operation improvements and market instruments are cheaper options than grid reinforcement(Leisch and Cochran, 2015).

3.5.4. Demand-side management

Demand side management is one of the central methods used to improve the flexibility of the electrical system. It consists of using different techniques in order to influence the final electricity consumption according to the grid’s characteristics. Load levelling, valley filling, and load shifting are some of the demand management mechanisms. It consists in the *planning, implementing, and monitoring activities of electric utilities which are designed to encourage consumers to modify their level and pattern of electricity usage* (EIA, n.d.). Therefore, with this solution, the consumers become active participants in the energy system (i.e. they become prosumers).

Load levelling is one of the main methods used as it can reduce the peak of electricity consumption. It requires imposing time-of-use rates, to offer interruptible contracts to potential users, such as manufacturers, or to put into place programs for the removal of energy-consuming devices. On the other hand, when demand is low, it is possible to increase the consumption via valley filling or fill-in-times. Thus, it is possible to increase the consumption using the charging of electrical vehicles, for instance (Chen et al., 2014). It is also possible to shift the demand, such as shifting part of the peak-period demand towards off-



peak periods through tariff incentives (Sinha and De, 2016). The core objective is to flatten the diurnal electricity demand curve and avoid strong hourly load variations, i.e. peak and off-peak.

The implementation of these techniques, based on price signals, has two main benefits: for the consumers it can represent a saving in electricity bills, whereas for the grid it allows to shift the energy consumption from peak to non-peak hours. The target customers are typically residential and industrial ones. However, a proper market design should be assessed to make this solution a viable flexibility source for the system. At this aim, the introduction of a new figure called aggregator, whose role is to manage the energy potential coming from the demand side, is gaining pace in the electricity market.

In recent years, improvements coming from the automation of the demand side management and based on the Internet of Things (IoT) are emerging. For example, in smart homes different devices such as local battery storage, rooftop solar PV, home appliances and smart meters can be connected to exchange information at the aim of optimising the energy efficiency and the consumer's responsiveness to price signals (IRENA, 2019).

3.5.5. Sector coupling

Another source of flexibility in the demand side, particularly suitable when high shares of VRE are included in the energy systems, is sector coupling. It consists in the conversion of the power generated from VREs to different types of energy carriers for use across multiple sectors. Conversely, the process can be used to turn back energy carriers into power (IRENA, 2019). This practice results in an electrification of heating and transport, providing flexibility to the grid if well managed (Van Nuffel, 2018). Indeed, exploiting the electricity production surplus of VREs, this solution can avoid curtailment and decarbonise the energy system by avoiding the use of conventional generators.

In the practice, this is made through the implementation of power-to-X solutions. One of the possibilities is the coupling of power with heat (in this case it is called power-to-heat), that exploits VREs production to generate heat through heat pumps or electric boilers. This heat is then used for the climatization of buildings. With this technique the electricity can also be stored in thermal storages, that can operate at seasonal level. Another possible solution is power-to-gas, consisting in conversion of electricity from VRE into gas (methane or hydrogen). This is made through the use of electrolyzers, that convert water into hydrogen and oxygen (in the case of methane a second reaction with CO₂ takes place afterwards). The hydrogen produced by this reaction can then be stored and successively used in fuel cells to generate heat and electricity, operating as a seasonal storage or as a fuel for vehicles in the transportation sector.

3.5.6. Flexibility of the energy market

The structure of the electricity market can have an impact on the flexibility of the system (Lund et al., 2015). As wind and solar energy have a marginal cost close to zero, the price of electricity on the market could reach as low as zero or even negative when there is excess production. In a competitive and perfect electricity market, low electricity prices mean low revenue to VRE produces and less costs to consumers. In such instances, the revenue is not big enough to cover the investments costs of the VREs and hence a longer payback period. Thus, this phenomenon has triggered the introduction of capacity markets in many places across the world (Griffes, 2014). Besides, one may wonder if the market provides enough incentives on flexibility to producers. In other words, one may wonder if producers are being encouraged enough to vary their production in order to contribute to grid management.

3.5.7. Power system transformation

The integration of high shares of VREs requires therefore a real transformation towards more flexible and integrated energy systems. At this aim, the traditional energy system structure, characterised by unidirectional energy and monetary flows (the first ones from producers to consumers, the second ones from consumers to producers) and in which flexibility is only provided by the supply side, should be revised.

This could be made by introducing enabling technologies, but also innovative policy strategies, smart measures and efficient governance (Child et al., 2019). By doing so, it would be possible to unlock the full flexibility potential of the energy system, that comes both from the supply and demand side. Ultimately, these

innovations will lead to a more decentralised, efficient and flexible power system, in which energy and monetary flows become bidirectional (cf. Figure 7).

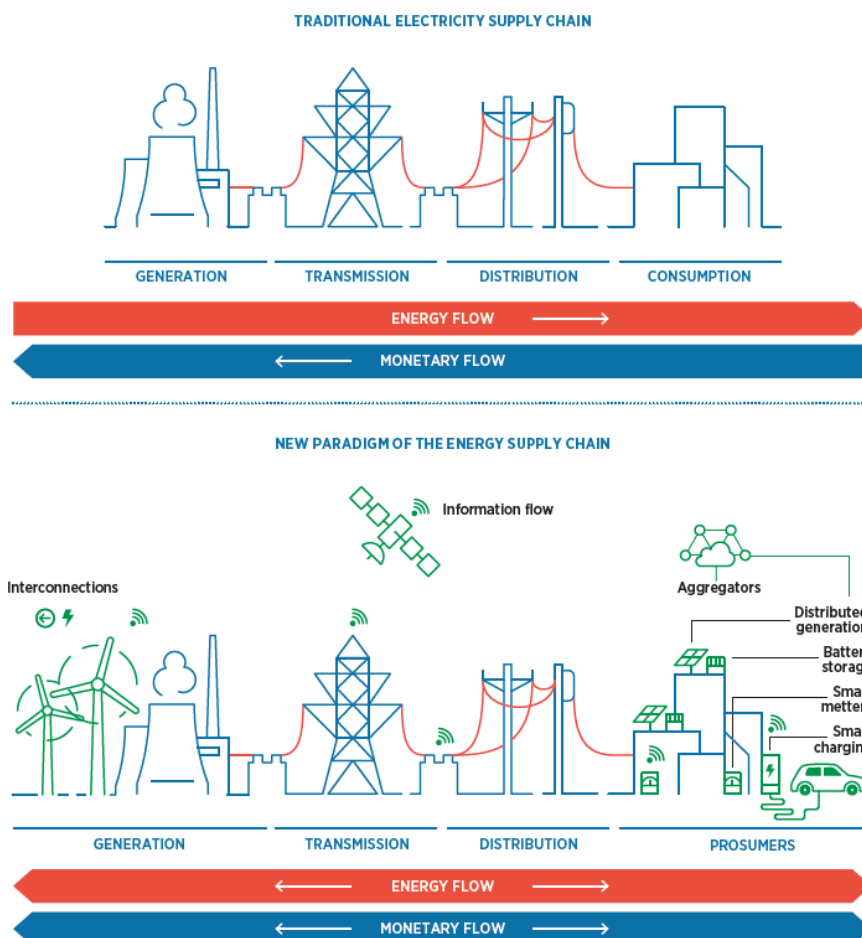

Figure 7: Innovations in the electricity supply chain (source: IRENA (IRENA, 2019))

4. GIFT SOLUTIONS FOR FLEXIBILITY

The GIFT project aims at decarbonising the energy mix of the islands through the development of different solutions. In particular, the ones considered for the project are:

- Virtual Power System
- Energy Management Systems for factories, harbours, homes
- Better prediction of supply and demand and visualisation of those data through a GIS platform
- Storage systems allowing the synergy between electrical, heating and transportation networks

The use of these solutions guarantees the increase of the flexibility of the system. Indeed, the new technologies that exchange energy with the electric grid (consumption or production) are provided with an Energy Management System (EMS), an informatic tool based on an automation system that allows monitoring, controlling, and optimizing the energy performance of the device. All the technologies are then integrated in a Virtual Power Plant (VPS), a decentralized automatic trading platform developed by INEA to implement the demand-response. The platform represents the meeting point between demand-response suppliers (consumers, producers, prosumers), intermediaries (aggregators, Virtual Power Plant) and users (network balancing manager, transmission and distribution system operator), that can trade energy capacities in real time. In practice, the integration of the new technologies in the VPS is made through the use of a Flex Agent (FA), an informatic solution that assures the flow of information about operational and



flexibility data between the two. The exchange of this information is assured by the FA through the use of a specific communication protocol named FLEX OFFER.

A diagram of the GIFT system architecture is shown in Figure 8.

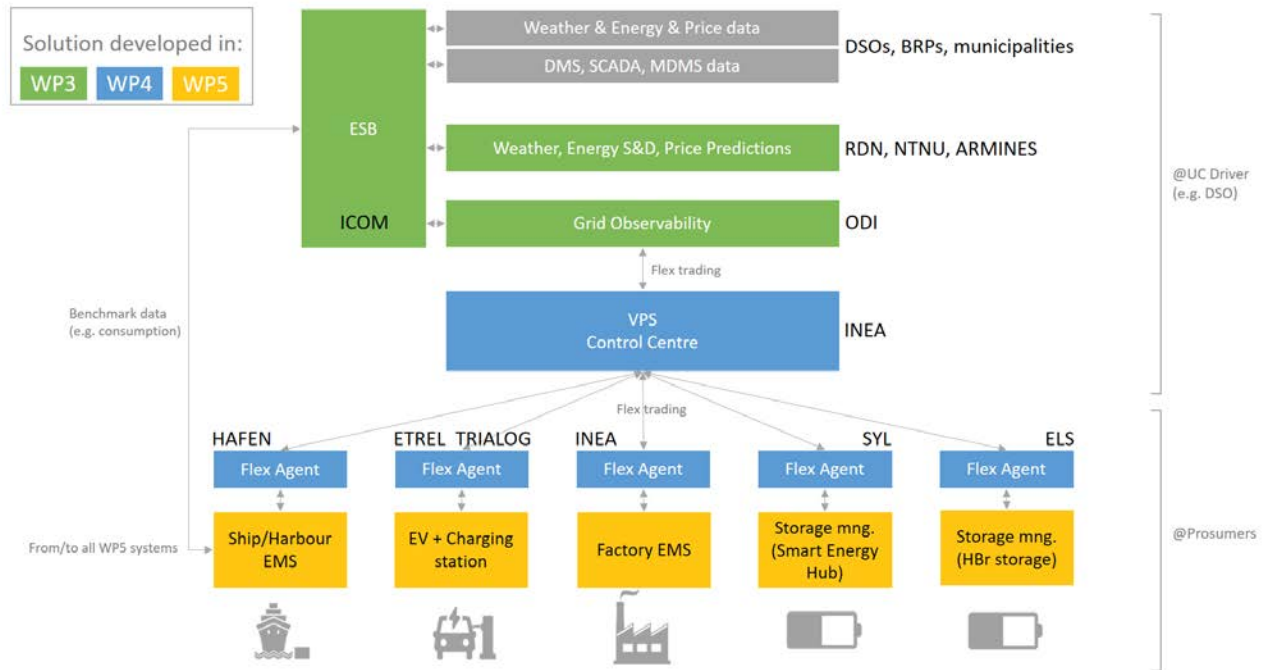

Figure 8 - Diagram of the GIFT system architecture

4.1.1. Grid observability

Increasing grid observability is one of the proposed solutions in the GIFT project. It could be implemented through algorithms and software based on IoT (Internet of Things) technologies, smart meter data, and existing historic data to build an empirical model of the distribution network. The model will then be used, among other things, to:

- Provide the state of the grid (state of active and reactive power, voltage and frequency) for each node.
- Provide a status forecast (load and voltage) for each node in real time or for the next day based on consumption and production forecasts.
- Predict the impact of new distributed energy resources (DER) and make recommendations for location optimization and/or network reinforcement.

The solution replaces the theoretical model with an empirical one. Instead of collecting unreliable and/or theoretical information on the network architecture, the model is built on real-time smart meter data. The building of the model goes through a stage of “training” of the distribution grid, drawn by machine learning algorithms. This stage is based on the charge and tension curves which have been collected by smart meters during a given period (generally one month). Other external data, such as meteorological data (temperature, hours of sunlight, etc.), can also be used in order to improve accuracy. Once the training stage is over, the model can be used to predict the impact on the network of any load or change in production. Since the model is built directly from field measurements, it recreates the real behaviour of the network. The predictions obtained are therefore much more accurate than those obtained by conventional methods.



4.1.2. Prevision and visualization of electricity demand and supply

The modelling of the energy supply, and the forecast of energy demand through physical approaches of machine learning and hybrids, will support decision-makers for the choice of energy mix and will allow the integration of wider renewables energies in the grid. This solution is being developed jointly by RDN⁶ and NTNU⁷.

4.1.3. Virtual Power plant System (VPS)

Developed by the INEA, VPS is a decentralized automatic Demand Response exchange platform, linking Demand Response suppliers (consumers, producers, and prosumers), intermediaries (aggregators, Virtual Power Plant) and users (network balancing manager, transmission and distribution system operator).

The basic functionality of VPS is the actual negotiation of energy flexibilities, described in time, energy and price, as well as several other technical and economic parameters. This allows the technical and economic optimization of the entire electrical system. The technology fully supports the cellular approach and places the role of the prosumer at the centre of the system. The trading algorithms integrated in the VPS allow the generalization of any producer or consumer, making it the ideal choice for holistic energy management at all levels. The VPS platform can be cloud-based or installed on site.

Flex Agent is a way to ensure common communication protocols, as well as a set of tools for the extraction, negotiation and execution of flexibilities. The use of Flex Agents will allow the generalization of every solution so that their flexible energy can be exchanged on the VPS platforms. Flex Agent grants a widespread adoption as many existing technologies can be reused without the costly installation or replacement of existing systems.

4.1.4. Energy management system at harbour

The energy management system at ports and on-board battery capacity of electric ferry/ships (E-Ferry) could potentially be used as a flexibility source. In Norway, some electric ferries are already operational. The E-ferry is expected to be a prosumer by offering electric flexibility during an individual charging session which is shifted during peak hours to release the stress on the distribution grid. The e-ferry charger is triggered by the ferry on arrival on the portside installation. To that end, HAFEN⁸ has developed a smart charging solution on ports.

4.1.5. Factory Energy Management System (FEMS)

FEMS (Factory EMS) is a solution that extracts flexibility from processes in different industries, especially when explicit storage/buffer or operation shifting in time is possible. The available energy capacities for flexibility depend on the industrial site.

4.1.6. Electric Vehicles Charging stations

In the project it is of interest to develop and test an electric vehicle charging energy management system (EVC-EMS) capable of exploiting the flexibility of the charge for different energy management purposes. The basic component of the system is one or more charging stations (clusters) installed in the low voltage grid of the final electricity customer (household, residential or commercial building, or industry).

The approach consists of the "EV+Recharging Station" couple as a Distributed Energy Network (DER) offering local flexibility. This DER can contribute to the regulation of voltage, frequency and power demand.

⁶ <http://www.rdnester.com/>

⁷ <https://www.ntnu.edu/>

⁸ <https://hafenstrom.com/>

4.1.7. Storage technologies

In the framework of the GIFT project two different storage technologies will be used to increase the system flexibility.

4.1.7.1. Smart Energy Hub (Sylfen)

The Smart Energy Hub is an energy system proposed by Sylfen⁹, composed by a reversible Solid Oxide Fuel Cell/Electrolyser Cell (rSOC) technology developed by the CEA¹⁰ coupled with a hydrogen storage unit and a Li-ion battery. A battery management system (BMS) is integrated to control the system operation.

In the rSOC module the system can work either as an electrolyser or as a fuel cell. In the first case an electrolysis process takes place, transforming water into oxygen and hydrogen in gaseous phase thanks to the passage of an electric current. When the device works as a fuel cell instead, hydrogen is used to produce electricity. Therefore, the first process corresponds to energy stock (in the form of hydrogen); the second one to energy release (in the form of electricity and heat).

The Li-ion battery (50 kWh) provides instead a short-cycle storage and is used to cover the peak power needs.

The Smart Energy Hub presents a modular design, adapted to cover a wide spectrum of power range, and it is designed to improve energy savings, autonomy and flexibility of buildings. It is conceived to allow:

- the storage of excess energy generated by solar panels
- the energy release to cover electricity and heating needs in periods of high demand or low renewable energy production

4.1.7.2. Flow battery (Elestor)

The Elestor flow battery is a HBr (hydrogen bromide) system designed to store the energy produced by renewable energy systems. It has a capacity of 250 kWh and it is composed by two bidirectional inverters that can achieve a total nominal power rating of 50 kW.

The electrolyte is a solution of hydrobromic acid (HBr) and bromine (Br_2) in water. A reversible chemical reaction between the two active components (hydrogen, H_2 , and bromine Br_2) taking place in the electrochemical cells allows the release or stock of electrical energy. The active materials are separated by a membrane and they circulate in a closed loop in their own respective space and with their own storage. The H_2 and the electrolyte are stored in two separate tanks (see Figure 9).

This technology is particularly well suited for large-scale, non-automotive and long-term electricity storage. As opposed to a closed battery, a flow battery parts are easily accessible and suitable for maintenance and upgrading such as the circulation pump, valves, electrochemical cells, and its control system. It is also modular in capacity suitable for upgrading and better use of economies of scale and hence, a reduced levelized cost of energy. The HBr battery will be connected to the EMS through a BMS.

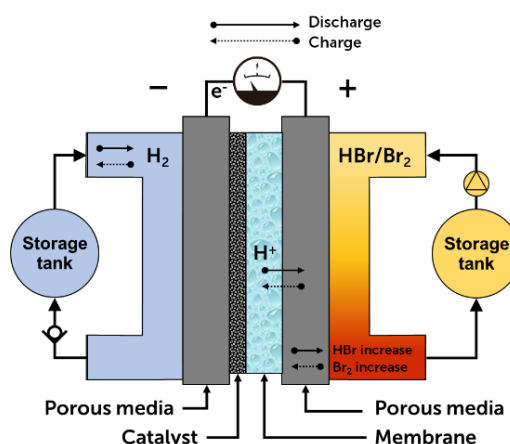

Figure 9: Diagram of the flow battery

5. LONG-TERM ENERGY PLANNING

⁹ <https://sylfen.com/fr/accueil/>

¹⁰ <http://www.cea.fr/>



5.1. OVERVIEW ON ENERGY PLANNING

Designing and building new transmission lines can take several years and often is expensive. Therefore, planning is a critical activity to ensure that the power system presents sufficient flexibility to accommodate the integration and growth of variable renewable energy, especially with the increasing concern of climate change and optima earmarking of limited energy resources (Cochran et al., 2014; Gaur et al., 2019).

The planning process is divided into two categories: expansion and operational planning according to the time horizon covered and type of decisions that it supports. The main tasks of each of these two categories are described as follows:

- a) Expansion planning (long-/mid-term):** determining the future expansion investment, at least possible cost, required in the power system to supply the forecasted demand while complying with techno-economic and environmental constraints. (IAEA, 1984).
- b) Operation planning (short-term):** determining the optimal generation schedule for the upcoming operation period. It involves network studies (load flow, stability, etc.) to evaluate whether the planned generation schedule would meet the forecasted load according to the technical limits of the equipment and system stability and security. Due to the short-term nature of this process, investment in new equipment is not feasible, thus system operation is made based on the control variables of the generating units (active and reactive power), transformers (tap position), reactor and capacitor banks (taps) and network topology (network switching). (IRENA, 2018b)

As minimizing the cost of the power supply system is a common objective, (IRENA, 2018b) points out the trade-off between reliability and cost. When considering variable renewable energy (VRE) integration, the target VRE share can be seen as a third dimension to this planning trade-off. Different strategies can be followed for long-term planning of the power system, depending on the objectives that one wants to achieve regarding these three dimensions.

Some of the most common approaches are broadly described below:

1. Set a targeted reliability level for the system and a target share of VRE in the energy mix (or even the planned VRE roll-out) and minimize the total future costs of the system to achieve these levels.
2. Set a targeted reliability level for the system and the allowed total cost of evolution of the system and maximize the share of VRE. If the allowed costs are set to zero, this consists in finding the maximum amount of VRE that can be integrated into the existing system (i. e., the hosting capacity).
3. Set a targeted reliability level for the system and optimize both the VRE deployment strategy and the other system evolutions in order to minimize total costs.
4. Set a targeted reliability level for the system and apply a multi-criteria evaluation to find a suitable trade-off between VRE share and total system costs.

5.2. LONG-TERM PROSPECTIVE MODELLING

Prospective modelling is a mathematical tool that can be used to support long-term strategic planning in the face of uncertainties related to future events. The analysis is based on the definition of possible future trajectories, or scenarios, with the aim to compare contrasted possible future outcomes (Postic, 2015). A scenario can be used to prove that a desirable future is attainable or to explore possible evolutions when adopting different strategies.

When applied to energy systems, prospective modelling can provide a valuable support for energy planning.



The long-term prospective modelling analysis of the islands investigated in the project is based on the use of a TIMES¹¹ model. It is an economic model generator that can be applied to systems of any dimension, which provides a technology-rich basis for representing energy dynamics over a multi-period time horizon (Richard Loulou et al., 2016).

A description of the model principles, based on (Richard Loulou et al., 2016), is presented in detail in section 5.2.1.

5.2.1. TIMES Modelling approach

The TIMES/MARKAL model developed since the 1970s as part of the IEA's ETSAP program¹² provides an economic representation of an energy system at the local, national, multi-regional or global level.

It is a bottom-up technology rich linear optimisation model that comprises of a high-level description of the system and its processes. In particular, each technology is explicitly identified and defined by a description of its inputs, outputs, unit costs, and other technology-specific technical and economic parameters. It is vertically and horizontally integrated model that all the technologies are linked with each other by their inputs and outputs to constitute the energy system.

More specifically, in TIMES the three types of entities are used:

- **Processes, *p***: representations of physical devices that transform one or more commodities into other commodities. These can be for example raw material extraction processes, power plants or vehicles.
- **Commodities, *c***: they can be consumed by processes or produced by them. Commodities include energy carriers, raw materials, financial flows or emissions.
- **Commodity flows**: link between process and commodities. A flow is of the same nature as a commodity but is attached to a particular process, and represents one input or one output of that process.

For the modelling purposes, the relationships between the technologies of the modelled energy system can be represented using a network diagram, referred to as a Reference Energy System (RES). **Figure 10** shows an example of RES. In this type of representation, the processes are pictured as boxes whereas the commodities as vertical lines. Commodity flows are the links between process boxes and commodity lines.

¹¹ TIMES is an acronym for The Integrated MARKAL-EFOM System

¹² <https://iea-etsap.org/>

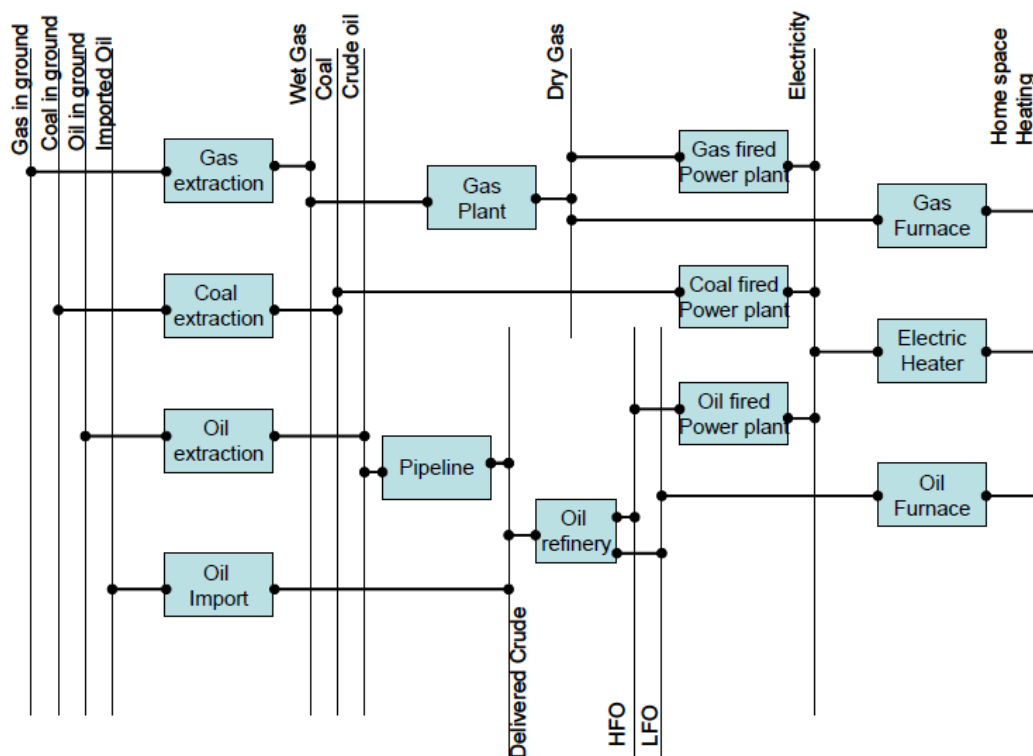

Figure 10: Example of Reference Energy System (source: (Richard Loulou et al., 2016))

Each process and flow of the RES should then be technically and economically defined in the model, by either quantitative or qualitative data. In particular, TIMES is said to be *data driven*, as the effective structure vary according to the data inputs used to define processes, commodities and commodity flows to be used in the underlying TIMES equations.

Moreover, a TIMES model is multi-regional, in the sense that several different regions can be defined in the same model, each of them characterised by its own commodities and processes variables. The model is also geographically integrated, as relationships between regions can be defined (e.g. trades). There are no constraints to the number of regions, the only ones being related to computational difficulty.

The temporal structure of the model should also be defined. At this aim, a long-time horizon is divided into periods, t , chosen by the user, which are in turn divided into years. These can be divided into time-slices, s , which can represent the seasons, day-night or week-weekend distinction.

Finally, a TIMES model is driven by scenarios. Each scenario can be obtained through the definition of energy supply and demand curves, the set of possible technologies and a policy setting. In general, a reference scenario is generated by running the model in absence of policy constraints, that is then compared to other scenarios that include additional constraints.

Ultimately, the model requires the following information as input:

- the estimates of end-use energy service demands
- the existing energy technologies
- the characteristics of available future technologies
- present and future sources of primary energy supply and their potentials

TIMES is a partial equilibrium linear programming optimization model. It assumes perfect competition between market actors and determines the supply-demand equilibrium¹³ or market clearing point that

¹³ A market is said to have reached an equilibrium at prices p^* and quantities q^* when no consumer wishes to purchase less than q^* and no producer wishes to produce more than q^* at price p^* (Richard Loulou et al., 2016)



maximizes the *net total surplus* (i.e. the sum of producers' and consumers' surpluses). It assumes competitive markets; this implies that, the model computes the commodity flows and their prices, in such a way that the suppliers of energy produce exactly the quantities demanded by the consumers. Moreover, TIMES considers that the demands for energy services are elastic to their own prices, meaning that the price of producing a commodity affects the demand for that commodity and at the same time the demand affects the commodity's price. The outputs of the problem are decision variables determining the equipment investment and operation; primary energy supply; and energy trade for each region.

A TIMES model presents the following properties:

- The outputs of a technology are linear functions of its inputs
- The total economic surplus is maximized over the entire horizon
- Energy markets are competitive, with perfect foresight (meaning that that all investment decisions are made in each period with full knowledge of future events)

The first property implies that the optimization problem can be computed with Linear Programming (LP) techniques. This means that the equations used in TIMES are linear. However, non-linear production functions can be modelled in TIMES by decomposing them into piecewise linear functions. The linearity property also implies that each technology can be have any allowed capacity (defined by constraints) without economies or diseconomies of scale. To avoid unrealistic situations, TIMES allows including discrete investments by introducing integer variables (and thus making the problem an integer LP).

Considering competitive energy markets instead implies that the market price of a commodity is assumed to be equal to its marginal value, and each economic agent is rational in the sense that it maximizes its profit or utility function.

According to the hypothesis, the *net total surplus* is equivalent to the sum of producers' and consumers' surpluses. The supply-demand balance can be visualized by plotting the marginal production cost of the commodity as a function of the quantity supplied. Indeed, for a given commodity, the supply-demand balance (Q_E, P_E) is the intersection of the inverse supply and demand curve (cf. **Figure 11**). The inverse supply curve is defined as an increasing stepwise constant function; each step represents the maximum production of a technology (the order is based on the production price, so that the cheapest ones are used first). The inverse demand curve could instead either be implicitly defined in the model or defined by the user. The supplier's surplus at point S (in blue) is the difference between total income and total supply price. Similarly, the consumer surplus at point C (in red) is the substantial gain of consumers who buy at a price lower than the one they were willing to pay for the same quantity.

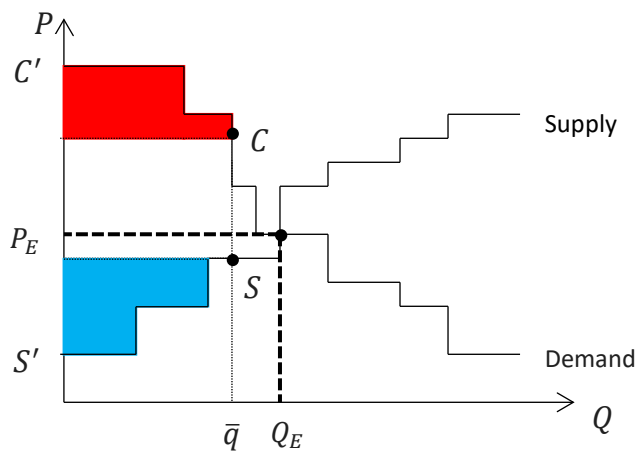

Figure 11: Supply-demand equilibrium for a given commodity (based on (Richard Loulou et al., 2016))

As the model assumes a perfect foresight the equilibrium is computed by maximizing total surplus in one pass for the entire set of periods (the balance point is then also called *inter-temporal dynamic equilibrium*).



5.2.2. TIMES Model decision variables

The decision variables are the unknowns of the model, to be determined with the optimization program. There exist many types of decision variables in the model. For a given region r , time period t (or vintage year v), process p , time-slice s , commodity c , the main ones are listed in **Table 2**.

Variable name	Description
VAR_NCAP(r,v,p)	New capacity addition (investment) for technology p , in period v and region r
VAR_RCAP(r,v,t,p)	Amount of capacity that is newly retired at period t . The new retirements will reduce the available capacity of vintage v in period t and in all successive periods $ti > t$ by the value of the variable
VAR_DRCAP(r,v,t,p,j)	Binary variables used in formulating the special early retirement equations
VAR_SCAP(r,v,t,p)	Total amount of capacity that has been retired at period t and periods preceding t
CAP(r,v,t,p)	Installed capacity of process p , in region r and period t , optionally with vintage v . It represents the total capacity available at period t , considering the residual capacity at the beginning of the modelling horizon and adding to it new investments made prior to and including period t that have not reached their technical lifetime, and subtracting retired capacity
VAR_CAP(r,t,p)	Total installed capacity of technology p , in region r and period t , all vintages together
VAR_ACT(r,v,t,p,s)	Activity level of technology p , in region r and period t (optionally vintage v and time-slice s)
VAR_FLO(r,v,t,p,c,s)	The quantity of commodity c consumed or produced by process p , in region r and period t (optionally with vintage v and time-slice s)
VAR_SIN(r,v,t,p,c,s) VAR_SOUT(r,v,t,p,c,s)	The quantity of commodity c stored or discharged by storage process p , in time-slice s , period t (optionally with vintage v), and region r
VAR_IRE(r,v,t,p,c,s,exp) VAR_IRE(r,v,t,p,c,s,imp)	Quantity of commodity c sold (exp) or purchased (imp) by region r through export (resp. import) process p in period t (optionally in time-slice s)
VAR_DEM(r,t,d)	Demand for end-use energy service d in region r and period t

Table 2: Summary of the main decision variables used in TIMES (based on (Richard Loulou et al., 2016))

5.2.3. TIMES Objective function



The maximization of the total surplus, calculated over all the regions and periods, can equivalently be expressed as a minimization of its negative value, that is the total system cost. The objective function is therefore expressed as:

$$\min(NPV) = \min(\sum_{r \in R} \sum_{y \in Y} (1 + d_{r,y})^{T_0 - y} \cdot ANNCOST(r, y))$$

Where NPV is the net present value of the total cost for all regions r and years y , R is the set of all the regions included in the model, Y is the whole time horizon, T_0 is the reference year, $d_{r,y}$ is the general discount rate in the region r and year y , $ANNCOST(r, y)$ is the total annual cost in region r and year y .

The annual cost, $ANNCOST(r, y)$, is defined at each year of the horizon (not only at each period), and includes 8 main cost (or revenue) components:

- Capital costs for *investing* into and/or *dismantling* processes
- Fixed and variable annual Operation and Maintenance (O&M) costs
- Costs incurred for exogenous imports and for domestic resource extraction and production
- Delivery costs for commodities
- Taxes and subsidies related to commodities consumption or production
- Decommissioning revenues (e.g. recycling of a commodity)
- Salvage value, to take into account monetary flows related to processes that exist even
- Welfare loss (in the case of elastic demand)

All cost elements are appropriately discounted to a specific year chosen by the modeller.

5.2.4. TIMES Model constraints

Several constraints can be defined in the model. The main ones are qualitatively described in the following. The mathematical formulation can be found in ANNEX III: TIMES modelling details (Richard Loulou et al., 2016).

- **Capacity transfer:** a constraint representing the fact that investing in a particular technology increases its installed capacity during its physical life, whereas at the end of its life, the total capacity is decreased by the same amount.
- **Process activity:** constraint that relates the activity variable to the appropriate set of flow variables properly weighted.
- **Use of capacity:** constraint that represents the fact that in each time period the model may partially or entirely use the installed capacity based on the Availability Factor (AF) of that technology.
- **Commodity balance:** constraint to indicate that in each time period the sum of production by a region and the imports from other regions of each commodity must balance the amount consumed in the region or exported to other regions.
- **Flow relationships:** constraint for processes, indicating the conservation of mass flows.
- **Flow share:** constraint to limit the share of each flow.
- **Peaking reserve:** constraint to bound the lower limit of the total capacity of all processes producing a commodity at each time period and in each region by a certain percentage, with respect to the average demand in the time-slice where peaking occurs.
- **Commodities constraints:** bound for the commodity variables in each period.
- **User defined bounds:** user defined constraints, that may involve any TIMES variable.



The variability and uncertainty related to VRE sources needs to be addressed across a wide range of timescales, from real-time operations to seasonal imbalances. The introduction of these sources in power systems can therefore give rise to important challenges in long-term energy planning models, as it requires appropriate investment decisions to ensure the flexibility of the system.

Long-term energy models are characterized by a simplified representation of the power system. However, to properly capture flexibility issues and requirements in energy system models a higher level of detail is required. This detail concerns both techno-economic and temporal aspects. Concerning the first one, it could result necessary to represent constraints of individual power plants (e.g., the minimum operating point, ramp-rate restrictions, start-up costs) as well as detailed system constraints to ensure the reliability of supply (e.g., operating-reserve requirements) (Poncelet et al., 2018). Concerning the time definition instead, it may be necessary to use a finer time resolution to properly account for VREs' daily and seasonal supply variations, as well as to better integrate techno-economic constraints.

The need to properly represent the power system becomes much more relevant as the share of VREs generation (and consequently the variability of supply) increases. Indeed, several studies (as for example (Welsch et al., 2014) and (Poncelet et al., 2016)) show that, at high shares of VRE, low levels of detail might lead to sub-optimal solutions. In particular, a low level of detail determines an overestimation of the baseload generation and an underestimation of operational costs related to the power system operations, especially when the time resolution is not properly defined. On the other hand, too strict operational constraints can result in an overestimation in the investments for conventional generators (Poncelet et al., 2016).

Nevertheless, the increase in the level of detail of the model implies an increase in the model complexity and thus a much higher computational cost, that could give rise to unsustainable running times. Finding a balance between the computational cost and the level of detail becomes therefore crucial to better integrate the flexibility requirements in long-term planning models (HIDALGO GONZÁLEZ et al., 2015).

In this context, two main approaches could be used to integrate flexibility in long-term planning models (HIDALGO GONZÁLEZ et al., 2015). The first one consists in increasing the level of detail of the energy system by increasing the number of time-slices and including technical and economic constraints. This could be done by solving the model either with a deterministic or with a stochastic approach (e.g. to determine the energy production of VREs). As an alternative, the long-term planning model could be soft-linked to a unit commitment model. With this second approach, the generation mix obtained in the long-term simulation at given years is extracted and included in the second dispatch model, operating at a higher time resolution and including constraints related to single unit's operation, to verify the feasibility of the solution (if the solution does not ensure a proper system flexibility the long-term model is modified to respect the requirements).

The two solutions present pros and cons. Increasing the time resolution and directly including techno-economic constraints can provide a consistent result using only one model, however this methodology is subjected to computational limits and it requires the knowledge of a large amount of information. This could lead to uncertainty, due to the assumptions that could be made to fill data gaps, especially for the estimation of renewable energy potentials and the projection of future demand profiles (HIDALGO GONZÁLEZ et al., 2015). The second method is the preferred one, as it allows not to excessively increasing the level of detail of the model, still considering additional requirements related to flexibility. However, this methodology requires an iterative approach and the solution could be a non-optimal one.

In general, it is therefore important to properly assess the assumptions made for the model and validate the hypothesis, for example with sensitivity analysis. Another scope for improvement is the representation of energy markets, to capture market signals that indicate lacks of flexibility (HIDALGO GONZÁLEZ et al., 2015).

Finally, additional considerations can be made for innovative flexibility solutions, such as storage ones. Introducing these technologies in long-term models to avoid the use of conventional synchronous generators could indeed represent a valuable alternative to ensure the reliability of supply. For these solutions, different studies (such as (Diaz et al., 2019; Poncelet et al., 2018)) have shown that technical constraints play an important role in the determination of the solution. For example, in (Diaz et al., 2019) a



difference of more than an order magnitude in the investments on storages are found when a more detailed model is used (i.e. hourly resolution and full consideration of technical constraints).

6. LONG-TERM DISCUSSION ON PROCIDA

6.1. DEMONSTRATION SITE: THE ITALIAN LIGHTHOUSE

6.1.1. Main territory aspects

Procida is the smallest of the three islands composing the Gulf of Naples, after Capri and Ischia. It has an area of 4.26 km² and is located 3.4 km from the mainland. The municipality of Procida covers the entire island as well as the small neighbouring island of Vivara (0.4 km²) which is a nature reserve ((see Figure 12 for the location). The island's population in October 2019 was estimated to be of 10,428 inhabitants (ISTAT, 2019a) with a density of 2,449.1 inhabitants per km².

Concerning the electricity supply, Procida is connected to Ischia, another island of the Gulf, by means of a 30 kV submarine electric cable. The island is strongly dependent on electricity imports, as the possibilities for local energy production are limited. Indeed, only a few distributed photovoltaics generation units are present in the island, and the coast is a protected marine area. The city hall is currently the only public building equipped with solar panels, presenting a power of 20 kW (soon to be increased to 60 kW). Procida is also a popular touristic location, especially during summer. This results in intensive seasonal loads that sometimes lead to grid congestions issues.



Figure 12. Procida's location

6.1.2. GIFT Specific Objectives

The most important electricity loads of the island are related to residential sector (private houses) and service sector (hotels). Therefore, the main solutions developed with the GIFT project concern demand-side flexibility solutions, especially for service sector (tertiary) buildings. Additional solutions include an innovative hydrogen storage technology, the Smart Energy Hub, that is a cogeneration unit that will be installed in the city hall building to enable sector coupling. The development of these solutions would enhance the flexibility of the system and prevent from grid congestion problems, other than supporting the self-consumption with photovoltaics in the island.

6.2. THE ITALIAN ELECTRIC SYSTEM

6.2.1. Supply and demand

6.2.1.1. Electricity generation

The Italian electricity system is in line with the European directives to open up to competition, therefore it is disintegrated. Italy has an installed capacity of 118 GW, including 40 GW of combined gas-fired combined cycle power, 22 GW of hydropower and 19 GW of photovoltaics, as well as 9 GW of wind power (Terna, 2018).

In 2005, 83% of the Italian electricity production mix was composed of natural gas, coal and oil. However, in the years that followed, wind, solar, biofuels and waste took an increasingly prominent place in the mix.



Solar energy has experienced the strongest growth thanks to lower associated costs and the will of public authorities (IEA and OECD, 2016). Natural gas has always played an important role in the Italian electricity mix, and even if its share has decreased in favour of solar and wind energy, it offers significant flexibility to compensate for the variability of renewables.

The available capacity for the peak is 69 GW, which offers the country a generation surplus. Among the main reasons for this surplus are the decline in demand due to the decline in economic activity and the increase in renewable energy capacity. However, Italy is the European country with the highest imports share, 15% of its total consumption, due to the cost competitiveness of imported electricity compared to electricity sold on the national wholesale market.

The company with the largest installed capacity is Enel (31%) producing 21% of Italian electricity, ahead of Eni (9.1%) and Edison (7.7%) (Montella et al., 2018).

6.2.1.2. Electricity consumption

The industry is the largest consumer of electricity, accounting for nearly 40% of demand and just ahead of the service sector. The residential sector is in third place as there is a decline in demand, unlike the transport sector, whose share in the consumption mix is constantly increasing (IEA and OECD, 2016).

6.2.1.3. The electricity grids

The Italian grid operator is Terna since 2005 and its separation from Enel in the context of the disintegration of the electricity market. Under its responsibility, the company has the largest high-voltage network in Europe with nearly 64,000 km of transmission lines.

Terna has significantly improved the transportation network in recent years (IEA and OECD, 2016) to reduce the risk of congestion. Indeed, electricity prices in northern Italy have traditionally been relatively low compared to the South and the islands (notably Sardinia and Sicily), which created a regional disparity in prices. Thus, in 2014, the improvement of the North-South transmission network and interconnections with Sardinia led to a better alignment of prices between the different regions so that all consumers could benefit from the reduction in prices on the wholesale market due to the fall in the price of natural gas (dominant in the Italian production mix) and demand (IEA and OECD, 2016).

The Italian distribution network is the second largest in Europe after France and is operated by nearly 139 groups, the main one being Enel through a subsidiary, E-distribuzione, which accounts for 85% of the volume of energy distributed (Montella et al., 2018).

Finally, Italy is also connected to the rest of Europe with 4 high-voltage lines connecting it to France, 12 with Switzerland, 2 with Austria, 2 with Slovenia and underwater connections with Corsica, Greece and Malta. Thus, the country imports most electricity from Switzerland and France, Slovenia and Austria.

6.2.2. The electricity markets

6.2.2.1. The trading markets

The Italian wholesale electricity market is divided into two main parts:

- The Borsa dell'Energia Elettrica or Italian Power Exchange spot market which, as we have seen previously with Norway, consists of a day-ahead market (Mercato del giorno prima -MPG) and an intraday market (Mercato infragioraliero - MI). The market had 271 Zen participants in 2018 (mercatoelettrico.org, 2019) and is managed by the market operator Gestore Mercati Energetici (GME, 2017). In addition, a market for system services is operated by the network operator Terna, which constitutes and activates balancing reserves provided by balancing actors: producers, consumers, other actors likely to inject or withdraw energy onto the network in order to ensure a balance between supply and demand at all times and to solve congestion problems on the network.



- The futures market (Mercato elettrico a termine dell'energia elettrica – MTE) also managed by GME, which is increasingly successful in terms of trading volumes and offers participants the opportunity to hedge against price volatility (Ausubel and Cramton, 2010).

In addition to these two major markets, producers and buyers can conclude bilateral contracts that must be registered on the PCE (Piattaforma conti energia).

The wholesale price is calculated for six major geographical areas and four limited production poles (production groups with interconnection capacity below their production capacity). These area prices are aggregated into a single national price per hour, which is the average price per area weighted by total purchases, the NUP (Prezzo Unico Nazionale).

In addition, since 2011, Italy has coupled its day-ahead trading market with that of Slovenia in order to rationalize electricity exchanges between the two countries, i.e. exchanges from where prices are the lowest to where they are the highest, and in synchronization with the coordination of the transmission system operators, the respective power exchanges. Thus, in 2012, prices between the two regions converged 20% of the time (IEA and OECD, 2016). Since 2015, Italy has an extended market coupling with other neighbouring countries such as France and Austria, followed by Switzerland and Greece.

6.2.2.2. Electricity retail market

Consumers are free to choose their own power supplier since 1 July 2007 according to Italian law and EU directives for deregulated electricity market. However, residential and small and medium-sized enterprises may choose to remain under a regulated tariff regime and be supplied with electricity by the local DSO under a transitional regime, *maggior tutela*, and under certain conditions (Stagnaro et al., 2018) :

- The supplier is a legally separate company belonging to the same conglomerate as the local DSO
- The contractual characteristics are standardized and set by the energy regulator
- The price is set by the regulator, based on the costs incurred by Acquirente Unico on the wholesale markets.
- In order to match competitors' costs and not to harm competition, Acquirente Unico's wholesale cost is increased by a certain amount set by the regulator to match the assumed entry and operating costs of a new entrant.

The majority of residential customers and nearly half of small and medium-sized businesses have chosen to be under this regulated regime (ARERA, 2015), even though the number of consumers turning to the competitive market is growing significantly (IEA and OECD, 2016).

As for electricity prices for consumers, they contain four main components: distribution system costs, taxes and other charges for residential customers that are constituted: the cost of phasing out nuclear power, the cost of incentives for the development of renewable energies, compensation for the cost advantages of electricity to the national railway company (Ferrovie dello Stato), the cost of research on improving the electricity system and finally compensation for the various advantages granted to certain consumers benefiting from reduced costs (IEA and OECD, 2016).

6.2.3. The regulatory framework

Italian national law transposes the Directives of the European Parliament and of the Council of December 19th 1996 concerning common rules for the internal market in electricity, including its liberalization. As in the case for Norway, which we have seen earlier, Italian policy is to a large extent influenced by European energy policy directives (Montella et al., 2018).

6.2.3.1. The main actors

- Regulatory authority for energy, networks and the environment



Founded in 1995, ARERA (formerly AEEG) is an independent regulatory entity for the energy markets. It ensures consumer protection, the smooth functioning of competition and the quality of service. To this end, it maintains a transparent tariff system (in particular, it is responsible for regulating the prices of distribution and transmission networks) and defines service quality standards.

- Ministry of Economic Development

The MSE is responsible for national energy policy. It deals in particular with the budget and strategy of the energy sector, the promotion of renewable energies and energy savings, the establishment of competition in the electricity supply market, the reduction of greenhouse gas emissions or the dismantling of nuclear power plants.

- Energy services Manager

GSE is a public company under the Ministry of Economy and Finance that promotes and supports renewable energy sources. In particular, it shall seek to promote sustainable development by supporting the production of renewable electricity and by taking measures to raise awareness of the environmentally efficient use of energy.

- Electricity market operator

GME is a company created by GSE with the aim of organising and managing the electricity market economically. It establishes the conditions for access to markets as well as the rules concerning their organisation and functioning, and is responsible for managing the availability of a sufficient reserve of capacity. In addition, it is also responsible for managing the issuance of green certificates and energy efficiency certificates.

There are also Acquirente Unico players as we have seen above, a branch of GSE responsible for buying electricity on the market and reselling it to suppliers within the regulated tariff offer. In addition, the competition authority (Autorità Garante della Concorrenza e del Mercato - AGCM), an independent entity established in 1990, fights against anti-competitive agreements between companies, abuses of dominant positions, mergers and acquisitions likely to create dominant positions detrimental to competition.

6.2.3.2. The legal framework

As part of the European climate and energy package, Italy has committed itself to reducing its emissions in the transport, agriculture, buildings and services sectors (IEA and OECD, 2016). Italian climate change policies have been developed in the context of European recommendations, and the government is responsible for implementing measures, although the regions have acquired more and more responsibilities. Thus, within the framework of the Covenant of Mayors, nearly 1,300 local administrations have implemented climate plans and measures.

Thus, in March 2013, Italy adopted a national action plan for the reduction of greenhouse gas emissions for the period 2013-2020 and the country adopted a number of measures and mechanisms to promote the development of renewable energies. More recently, the National Energy Strategy on which the national energy policy is based has set new objectives for 2030, including the abandonment of coal by 2025 and the development of renewable energies based on gas for the stabilisation of the electricity system (DG Treasury, 2019). Thus, the objectives set are a 30% share of renewables in the energy mix and a 33% reduction in greenhouse gas reductions compared to 2005. As regards electricity consumption, the plan envisages in particular a 55% share of electricity produced from renewable sources. The main mechanisms set up in Italy to promote renewables are as follows (IEA and OECD, 2016; Montella et al., 2018):

- The Conto Energia feed-in tariffs

Established in 2005, this mechanism provided incentive tariffs over 20 years from the date of entry into service of the installation concerned and allowed to cover investment and operating costs. This is the main



support mechanism for photovoltaic energy, and it has been stopped for new installations since the cost threshold was reached in 2013. In 2015, 17 GW of capacity was supported by feed-in tariffs.

- Green certificates

These certificates were issued to renewable energy producers for installations commissioned between April 1999 and December 2012. They could be sold with the obligation to inject a green electricity quota into the grid, with unsold certificates being bought by GSE. The implementation period was 15 years for plants installed from 2008 onwards. Since 2016, certificates have been replaced by a premium feed-in mechanism whereby producers sell electricity produced from renewable energy sources on the market and receive a premium in addition to the market price for their electricity production.

- All-inclusive feed-in tariffs

It is an alternative to the green certificates that have been abandoned and a mechanism specifically dedicated to small renewable energy installations (no more than 1 MW capacity) commissioned from 2008. The tariff is granted for a period of 15 years and includes incentives.

- Energy efficiency certificates

These certificates are issued in the case of energy end-use savings through energy efficiency improvement initiatives and projects. Electricity producers must meet annual primary energy saving targets and are rewarded with these certificates. In the event that they do not achieve these objectives, they are obliged to purchase certificates on the market specially dedicated and managed by GME.

- Net counting service

Electricity produced by small-scale production installations, in particular by private individuals (20 to 500 kW installations) and fed into the grid, is remunerated by GSE on the basis of electricity injections and withdrawals in a given calendar year, according to their respective market values. This system has enabled the development of small-scale photovoltaic installations. It should be noted that a tax credit has also been set up to allow the development of self-consumption and amounts to 36% of the cost of the photovoltaic system since 2016 (IEA and OECD, 2016).

The generous incentives for the development of renewable energies and mainly for photovoltaics have enabled a significant growth in the number of installations with good production levels linked to good management and improvement of the electricity grid to support this expansion. However, these incentives have a cost that is passed on to the final consumer, and a peak of €12.5 billion was reached on July 2014, pushing the government to reduce these incentives.

6.3. MODELLING FRAMEWORK: TIMES-PROCIDA

In this section, the general approach and methodology used to develop TIMES-Procida is presented. All the technical aspects of the implementation are presented in the Annex I (Chapter 9).

6.3.1. Model horizon and tempo-spatial representation

In the new version of the model the time horizon is extended to 2050, still considering 2018 as the base year. Several periods are then defined, with a timestep that becomes progressively less refined as the final year of the horizon is approached. Each period is then split into three different seasons (winter, summer and a complementary intermediate season), that are in turn split into five blocks to represent different periods of the day (night, morning, midday, afternoon and evening). The final time structure is graphically shown in Figure 13.

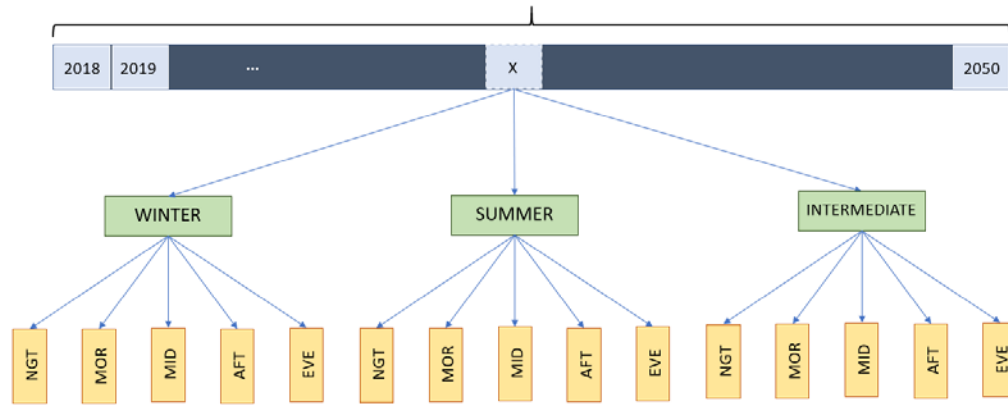

Figure 13: Time structure used for the model

6.3.2. Base year energy system

The energy system at the reference year (2018) is characterized by the definition of the demand and supply side.

In the practice, the characterization of the reference energy system is based on the data provided by E-Distribuzione for the island's electricity consumptions and production units (defined as an annual value for each of the users) and the one provided by the Municipality of Procida for the public electricity consumptions.

6.3.2.1. Demand side

The annual electricity demand in 2018 was 19,915,668 kWh.

For the characterization of the electricity demand for each end-use sector, as the data provided was not refined enough, the estimation is also based on the information provided in the PAES¹⁴ of Procida (the methodology used for the quantification is detailed in section 9.2.1.1).

The electricity demand is separately defined for the following end-use sectors:

- Agriculture
- Industry
- Tertiary
- Public
- Residential
- Transportation

The public sector is differentiated from the tertiary one as for this sector more refined data is available.

The estimated share of end-use consumptions by sector is shown in Figure 14.

¹⁴ The action plans proposed by the Municipality of Procida in 2015 within the European program of the Covenant of Mayors

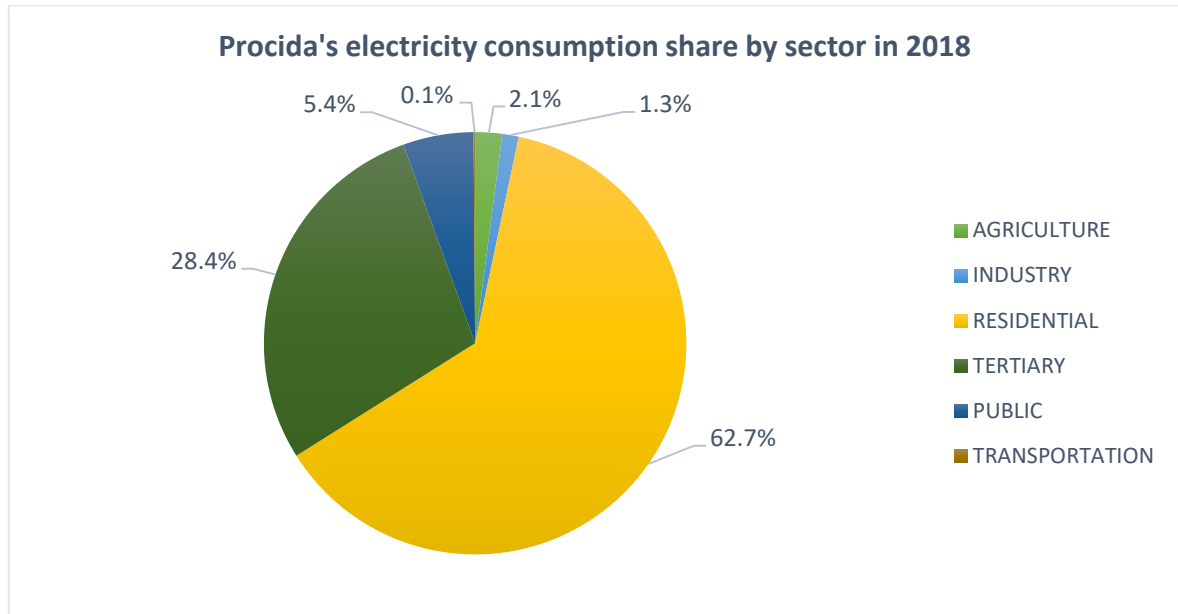

Figure 14: Estimated share of electricity consumption by end-use sector

For the modelling purposes it is necessary to allocate a share of the total annual load to each of the time-slices defined in the model. The definition of the load fraction at each time-slice is then based on assumptions, mostly based on the analogy with statistically-significant load curves. The methodology used to estimate the load fractions for each time-slice is explained in detail in section 9.2.1.

The electricity load fraction of the entire system per time-slice at daily level and distinguished by season is shown in Figure 15. As it can be seen, the peak of demand occurs in all the seasons during the evening, when the electricity production by photovoltaics is not available. However, care should be taken that at seasonal level the profile obtained is probably not representative of the island context because, as stated by the Municipality, grid congestion problems were faced during summer, suggesting that a greater load occurs in that season with respect to the other ones. This represents a major limit of the analysis.

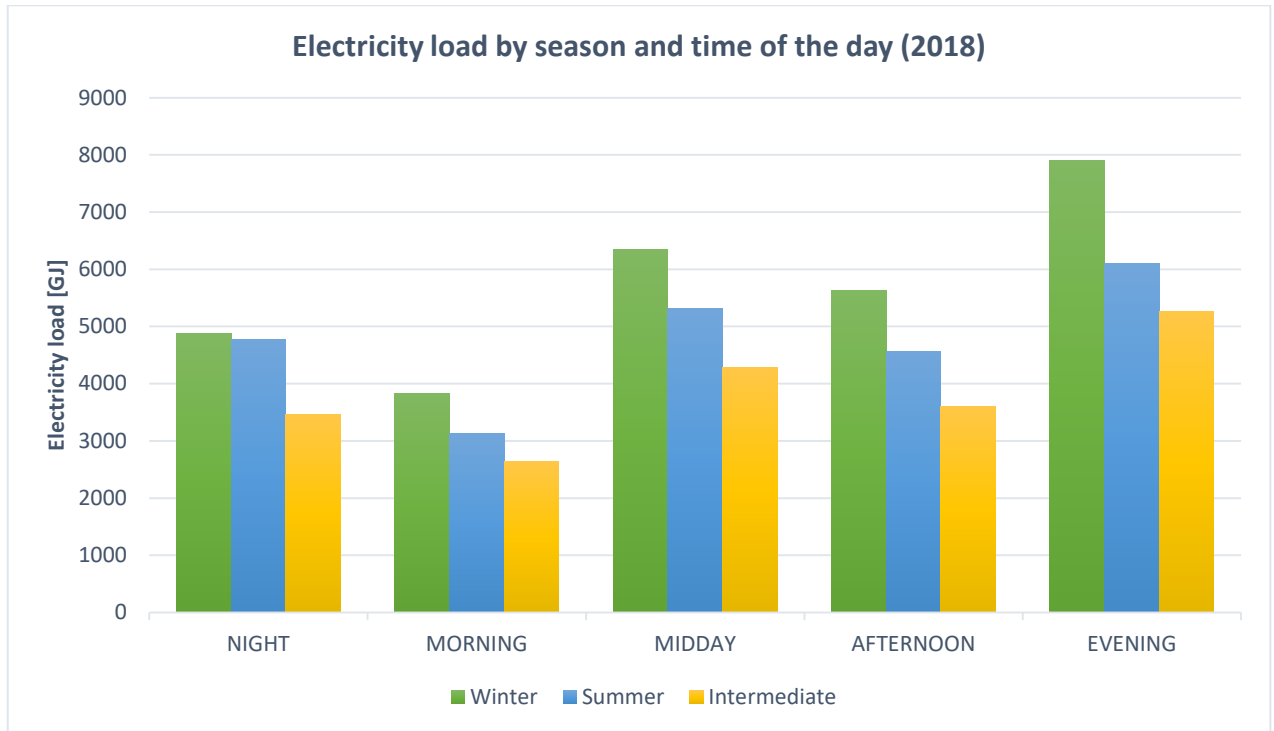

Figure 15. Estimated electricity load fraction per time-slice at daily level in 2018

6.3.2.2. Supply side

Concerning the supply, the island is strongly dependent on the imports from the mainland, that cover about 99% of the electricity demand. The only alternative electricity source is the photovoltaics, with a total installed capacity of 268 kW in 2018. Of these installations, the largest share in terms of capacity is used for residential applications (85%).

Figure 16 shows a summary of the supply mix in Procida in 2018.

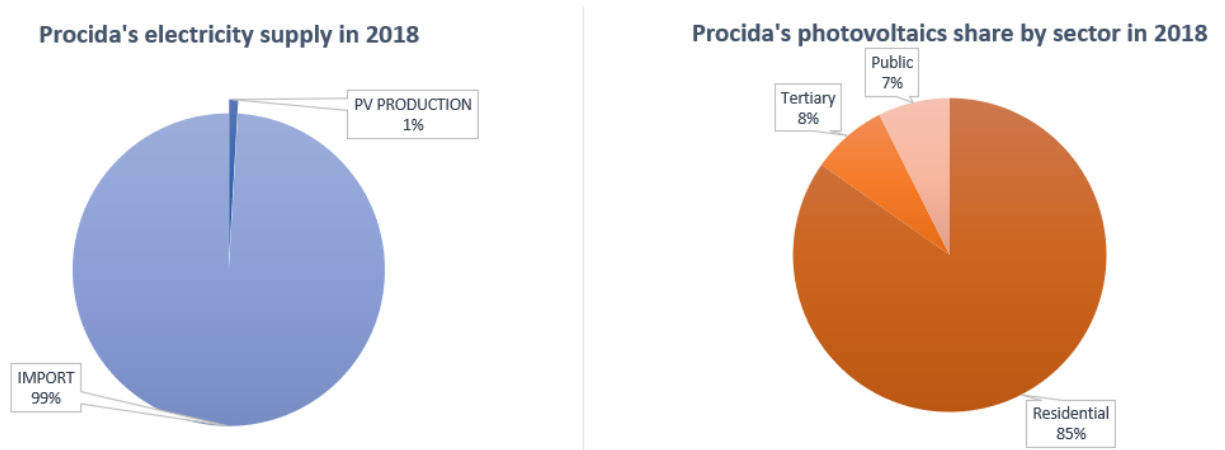

Figure 16. Procida's supply mix (on the left) and photovoltaics capacity share by sector (on the right) in 2018

Even for the electricity production by photovoltaics it is necessary to define the annual electricity production variation. This is made through the definition of a capacity factor for each time-slice. The methodology used to estimate this value, based on solar irradiance variation during the year, is detailed in section 9.2.2.1.

6.3.2.3. Base year model structure



As a summary, a simplified scheme of the reference energy system is presented in Figure 17.

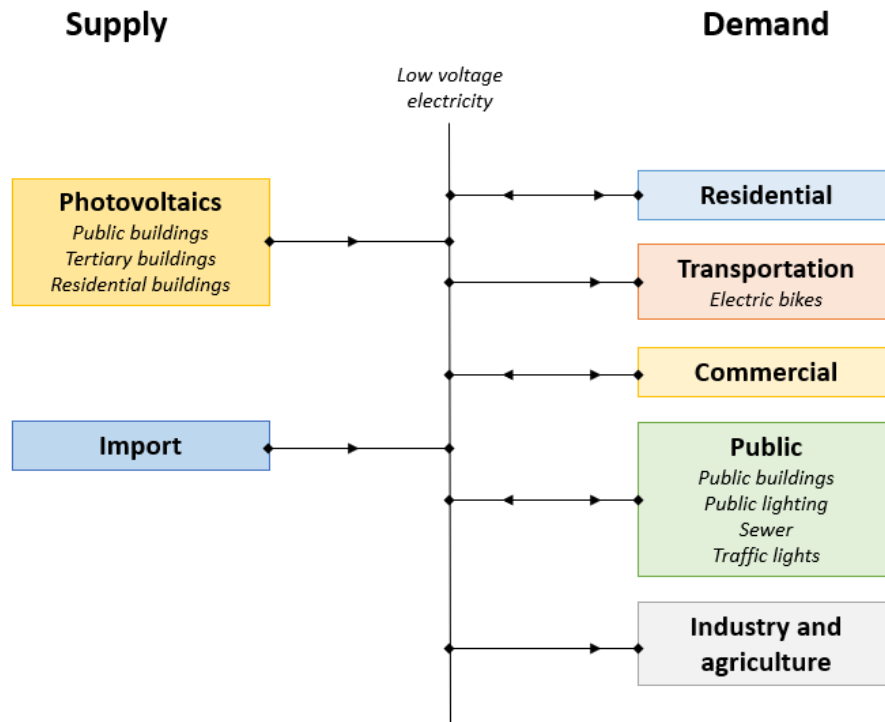

Figure 17. Simplified scheme of the reference energy system

It is relevant to mention that the model includes the possibility to reinject the excess of photovoltaics production in the low-voltage electricity grid. However, a price P_{inj} is assigned to this operation, that is defined as:

$$P_{inj} = P_{elec} - P_{spot}$$

Where P_{elec} is the price of electricity imports (see also 9.2.2.2) and P_{spot} is the average spot price of electricity in Italy in 2018 (61.31 €/MWh (Terna, 2019)). It is assumed that this price remains constant over the time horizon of the model. The electricity export is not considered.

6.3.3. Evolution in time

The estimation of the demand evolution over time and the choice of the new technologies to include in the model are detailed in the following.

6.3.3.1. Demand evolution

The evolution of the electricity load in time is based on the hypothesis that the driver for the electricity consumption is the Italian GDP. Indeed, this hypothesis results valid especially in recent years, as it can be observed in Figure 18.

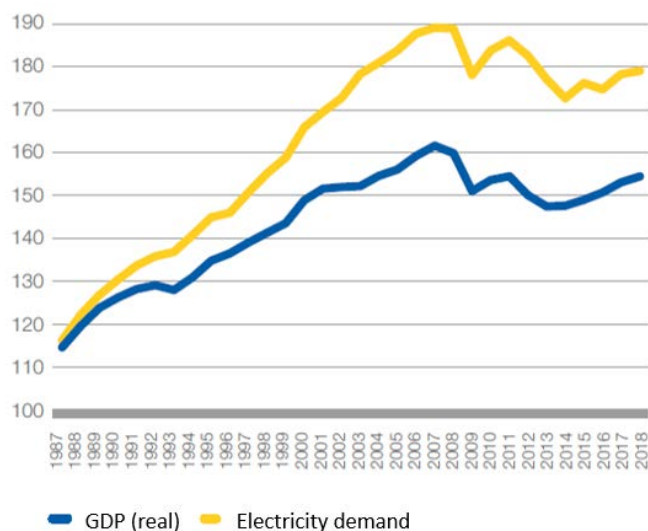

Figure 18. Comparison between Italian indexed GDP and electricity consumption trend (the reference year is 1987=100) (source: Terna, 2019 , based on Eurostat)

Based on this observation, it is assumed that the correlation between the electricity consumption and the GDP evolution is valid in future years too. The GDP value in Procida is assumed to grow by 0.5 per year, based on the choice made by (Terna, 2019) for moderate development scenarios in Italy.

It is assumed that the electricity consumption of all the sectors is proportional to the GDP value.

Exception is only made for public lighting consumptions, that are modelled as constant in time, because in the period between 2015 and 2018 Procida’s Municipality replaced the old light bulbs with LED ones reducing electricity consumptions of about 70% with respect to the ones in 2010 (that are reported in (Comune di Procida, 2015))

6.3.3.2. New technologies

The choice of the new technologies to include in the model is based on several considerations.

Concerning the electricity supply, only photovoltaics installed on buildings roofs are considered because of the constraints of the territory. The available area for installations in the island is indeed quite limited and the coast is a protected marine zone. Therefore, the final supply mix of the island is only constituted by photovoltaics and imports.

To increase the flexibility of the electricity grid other technologies are included in the model. In particular, both one of the solutions developed within the GIFT project, that is the Smart Energy Hub, and additional storage technologies are considered. However, as many different storage devices are available in the market, the most suitable ones shall be selected for cost and technical reasons.

Only distributed storage systems that can be coupled with photovoltaics are retained. Based on (Schmidt et al., 2019), the most suitable technologies designed for behind-the-meter applications are Li-ion, sodium-sulfur, lead-acid, redox flow and hydrogen batteries. Among these devices, based on (Zinaman et al., 2020), sodium-sulfur and lead-acid batteries are excluded, the first ones due to their stringent operating requirements (they operate at elevated temperatures), the second ones due to the fact that for this type of applications they are by now supplanted by li-ion batteries. Whereas li-ion batteries can retain the electricity for short periods (in the order of days), hydrogen storages and flow batteries used for behind-the-meter applications operate at seasonal level (Zinaman et al., 2020; Hydrogen Europe, n.d). As these two last devices are quite equivalent in terms of application and maturity of technology, it is chosen to only consider hydrogen (rSOC) systems as a long-term storage.



Finally, in accordance with the national context that promotes the decarbonisation of the transportation sector, electric vehicles are included in the model. Only vehicles operating with li-ion batteries are considered; hydrogen vehicles are not considered due to their high investment costs and early development/commercialization stage.

6.3.3.1. New photovoltaics installations

New photovoltaics are considered as a possible technology to install on buildings' roofs starting from 2019.

It is chosen to make a distinction between the PVs installed in residential, public and tertiary (private) buildings, in order to better analyse the contribution of the installation to the electricity supply of the sector it is referred to. In the case of public PV installations, the model is built in such a way to ensure that the electricity produced by the technology directly supplies only the energy needs of public buildings, excluding the other end-use electricity demands of the sector. For the other sectors instead, as the available data doesn't allow differentiating among the different end-uses, the photovoltaics electricity production can supply the entire sector demand.

The modelling approach as well as the input parameters used for this technology are detailed in section 9.3.2.1. It is relevant to mention that a lower investment cost is set for tertiary and public applications, due to economies of scale.

A constraint on the maximum installable capacity is set for each of the applications. The estimation of the maximum potential is detailed in section 9.5.1.

6.3.3.2. Li-ion battery

Li-ion batteries are considered for residential, tertiary and public applications to store electricity at daily level. The investment costs are lower for public and tertiary applications, due to economies of scale.

The modelling of li-ion batteries is detailed in section 9.3.2.2.

As for photovoltaics, a constraint is set on the maximum installable capacity for each sectorial application (see section 9.5.2). Moreover, an additional constraint is set on the maximum investments on batteries per year (detailed in section 9.5.3).

6.3.3.3. Smart Energy Hub

The Smart Energy Hub is composed by a li-ion battery and a rSOC system. The modelling approach as well as the input parameters used to define this technology are detailed in section 9.3.2.3.

6.3.3.4. Long-term storage

The long-term storage is defined according to the properties of the rSOC component of the Smart Energy Hub. In the model it is used for residential, tertiary and public applications.

The modelling approach and the input parameters used for this technology are detailed in section 9.3.2.4.

6.3.3.5. Electric vehicles

Electric vehicles (EVs) are included in the model as a demand technology, whose load depends on the fleet dimension, technical parameters and behavioural attitudes. Two different new electric vehicles are considered, namely electric cars and electric motorcycles. For electric bikes, already present in the island at the base year, it is assumed that the total amount does not change in time and that therefore the load remains the same.



For the modelling of EVs, technical parameters that characterise the performance should be fixed. The choice, based on average values and considering technology improvements in time, is detailed in section 9.3.2.5. Then, to estimate the new electricity load, a scenario is defined according to the fleet evolution in time and the users' behaviour.

Both for electric cars and motorcycles, it is assumed that all the vehicles belong to private residential users and that the charge only takes place at home. For electric cars, the definition of the fleet evolution in time is based on the Italian strategic plan for the energy system (PNIEC), that sets a target of 6 million passenger cars (electric+hybrid) by 2030 (about 12% of the total fleet in 2019). Starting from this objective, a trend¹⁵ for the Italian electric cars fleet is defined (see Figure 19). By analogy, the same evolution is then considered for Procida. The number of e-cars is then calculated by assuming that the total number of cars do not change with respect to 2018¹⁶.

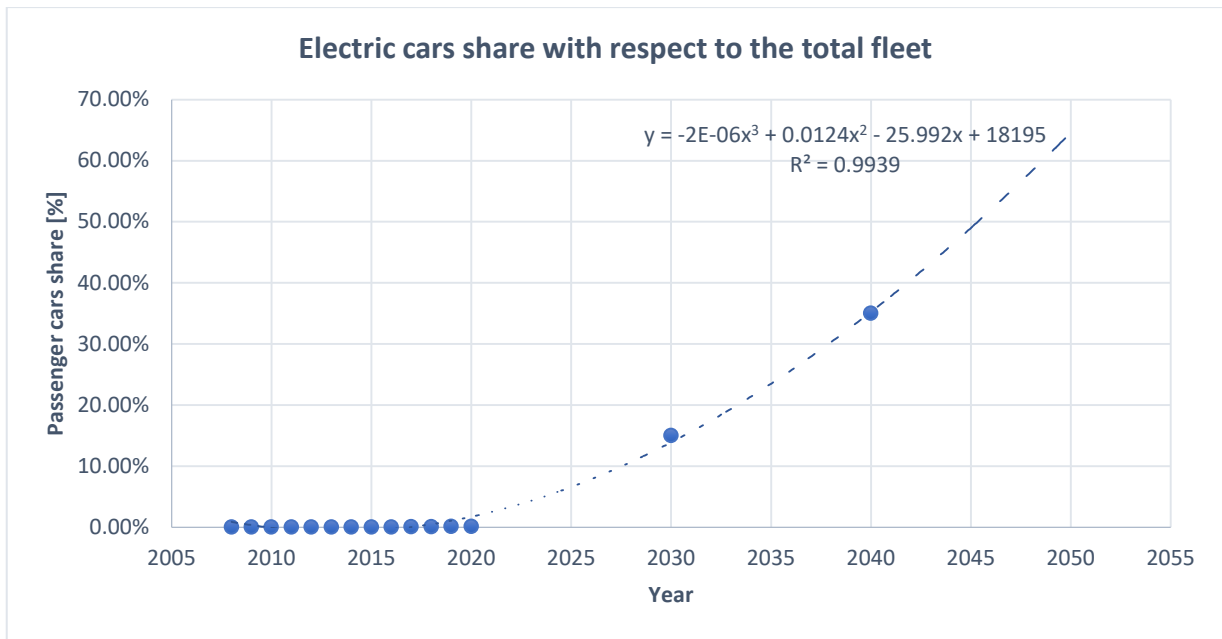

Figure 19. Scenario used to simulate the evolution of the electric cars share

Additional assumptions are then made for the users' behaviour. In particular, it is assumed that only one round trip and one charge per day and per vehicle are made, that the state of charge at depart is 100%, that the totality of the fleet is deployed each day and that the share of vehicles recharging at peak hours (evening (Robinson et al., 2013)) is 80%. The electricity load related to electric cars is then quantified with the calculation described in section 9.3.2.5.

For electric motorcycles the same methodology is applied. However, as in this case no reference was found to define the evolution of the fleet in time, some assumptions are made to define the share at specific years of the horizon. The evolution scenario is given in Figure 20. The same assumptions on the user's behaviour are made for the electric motorcycles and the electricity load calculation is based on the same methodology.

¹⁵ For the data for years before 2020 reference is made to (EAFO, 2020)

¹⁶ The total number of cars and motorcycles in Procida in 2018 is given by (ACI, 2019)

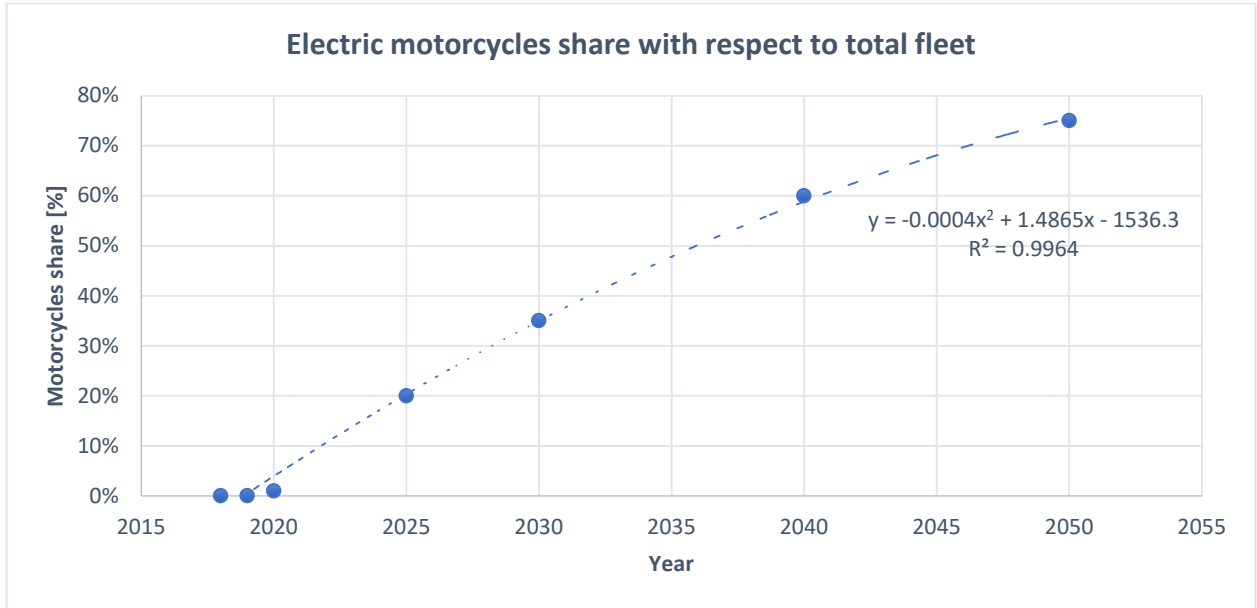

Figure 20. Scenario used to simulate the evolution of the electric motorcycles share

At high shares of electric vehicles in the total fleet significant changes in the electricity load during the day occur, especially at peak hours. Comparing the average daily load in 2018 and 2040 in Procida (Figure 21), the total load share during the evening increases by almost 4%. The introduction of EVs could then generate additional congestion problems, enhancing the need of flexibility solutions to manage load variations at peak hours.

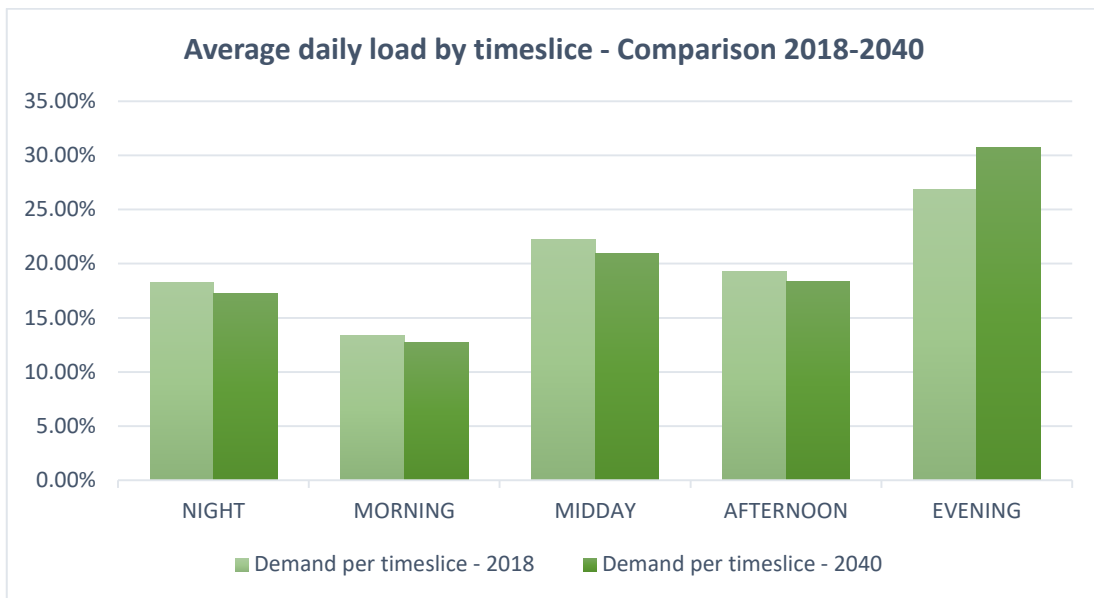

Figure 21. Comparison between the average daily load by timeslice in 2018 and 2040



As only two supply technologies are included in the model, in an optimal solution the use of the cheapest one is maximised. In the case of Procida it is the photovoltaics. The constraint on the maximum capacity of new annual photovoltaics installations results therefore decisive for the determination of the solution.

Due to this observation, it is chosen to consider two different scenarios for the future photovoltaics development in the island: a case of modest PVs deployment on the long-term (scenario *LOW*) and a case of large deployment (scenario *HIGH*). This is equivalent to analyse the effect of different local policies for the penetration of photovoltaics in the island (that are assumed to take place from 2020).

In the practice, the definition of the scenarios is made by imposing a constraint on the maximum amount of annual investments on photovoltaics at each year of the horizon. Moreover, an additional constraint is defined for each sectorial photovoltaic application to avoid investments on only one sector at the first years of the horizon. The definition of the constraints is better detailed in section 9.4.1 and 9.4.2.

The constraint used to define the two scenarios is graphically shown in Figure 22.

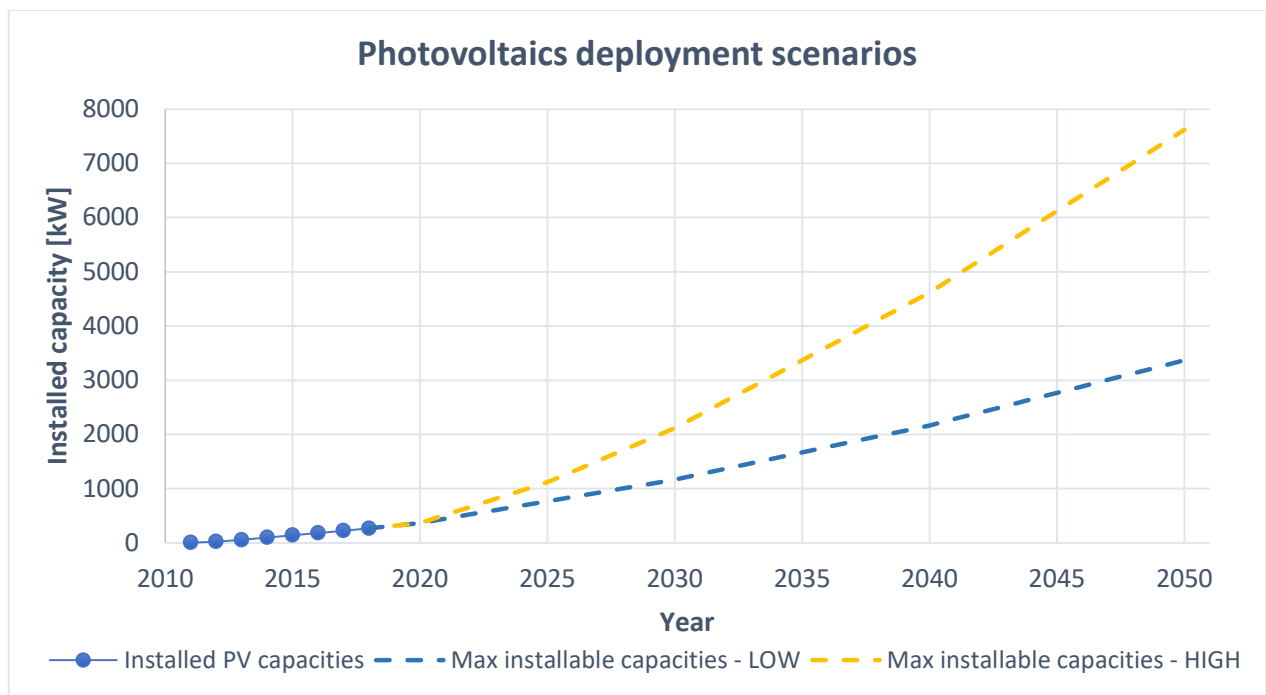

Figure 22. Max installable capacities constraint used to define the LOW and HIGH scenario

For the *LOW* and *HIGH* scenario only, photovoltaics installations and EVs (with the penetration scenario defined in section 6.3.3.5) are included in the model as new technologies. Another scenario that includes all the storage technologies is separately defined, with the objective to better evaluate the storage effects on the energy system evolution (scenario *HIGH_STG*). The comparison is made with respect to the high photovoltaics development scenario, as storage technologies are more meaningful with high shares of variable renewable sources.

Finally, an additional scenario in which electricity efficiency policies for the residential and tertiary sector (the most energy-intensive ones) are supported is considered (scenario *HIGH_STG_EFF*). The aim is to evaluate the advantages of such policies on the decarbonisation of the energy system of the island. However, since electricity devices already have quite high efficiencies, it is assumed that the improvement is quite modest, and that is made for example by promoting the use of heat pumps instead of other types of air conditioning systems. In the practice, this scenario consists in decreasing the electricity demand of the residential and tertiary sector over time by a fraction with respect to a reference year in which the policy is applied. In particular, it is assumed a consumption decrease of 0.25% with respect to the one in 2020 for 10 years and a decrease of 0.10% with respect to the one in 2030 for 20 years. The calculation of the new electricity demand for these sectors is better detailed in section 9.4.3.



A summary of the scenarios considered for the analysis is presented in Table 3.

Table 3 - Summary of the scenarios considered for the analysis

SCENARIO NAME	DESCRIPTION
LOW	Low renewables penetration scenario. The only possible investment is on PVs.
HIGH	High renewables development scenario. The only possible investment is on PVs.
HIGH_STG	High renewables development scenario. Investments on storage technologies are allowed.
HIGH_STG_EFF	High renewables development scenario. Investments on storage technologies are allowed. Electricity efficiency policies are implemented.

6.4. RESULTS

▪ Total discounted system cost

The total discounted system cost (in millions €) of the four scenarios is shown in **Figure 23**.

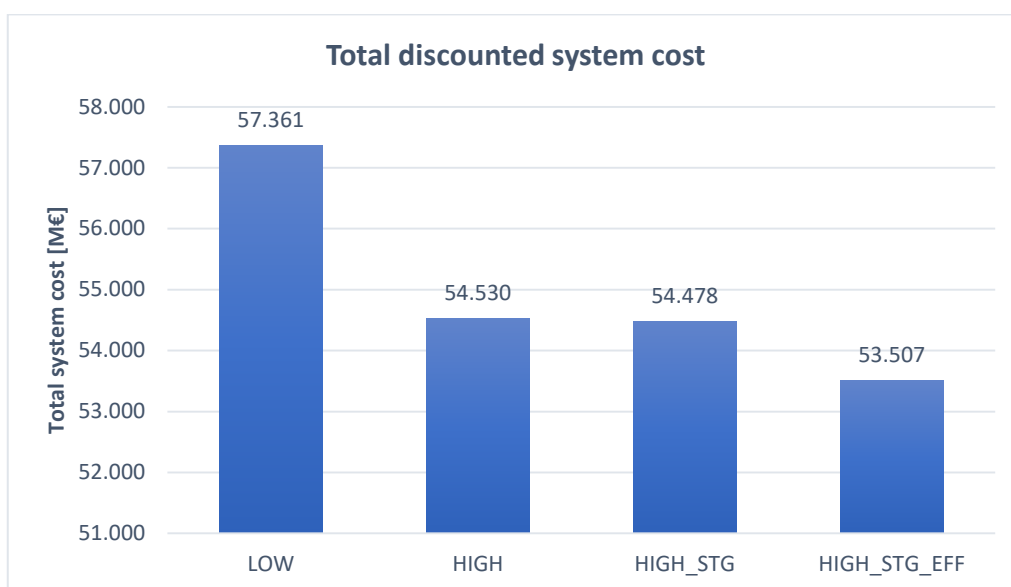

Figure 23. Total discounted system cost in the four investigated scenarios

The total cost of the system is higher in the *LOW* scenario (+5.2%), as in this case the island is more dependent on imports from the mainland, the most expensive electricity supply alternative. The difference is instead much less significant with the introduction of storage technologies and efficiency policies (-0.09% and -1.9% respectively), although in both cases the total system cost is lower. These results suggest that it could be economically convenient to promote self-consumption in the island.

▪ Investments in new technologies



As expected, the investments in new supply technologies tend to maximise the use of photovoltaics in all the scenarios, as the maximum number of installations per year is always attained (see **Figure 24**). Moreover, public and tertiary installations are preferred in the first years of the horizon, since their investment cost is lower with respect to residential ones due to economies of scale.

However, it is relevant to notice that in the cases in which investments on storage technologies are allowed the optimal choice for PVs investments changes. In this case, investments on photovoltaics installed on public buildings are preferred, as a larger amount is installed at the first years of the horizon.

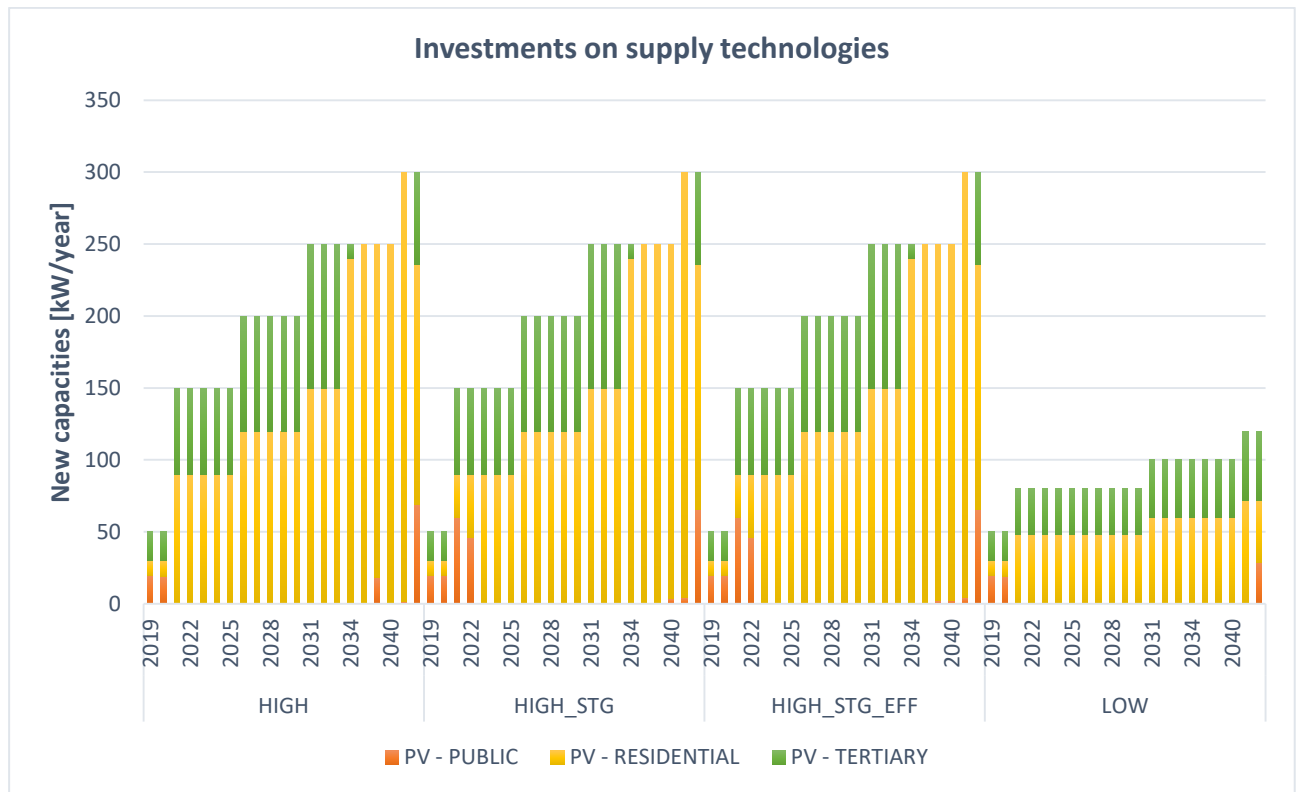

Figure 24. Optimal investments on supply technologies in the four investigated scenarios

The resulting optimal total installed capacities evolution is shown in **Figure 25**. As it can be noticed, the model maximises the photovoltaics for tertiary applications, reaching the maximum capacity (1.05 MW) in about 15 years in the high renewables' development scenarios.

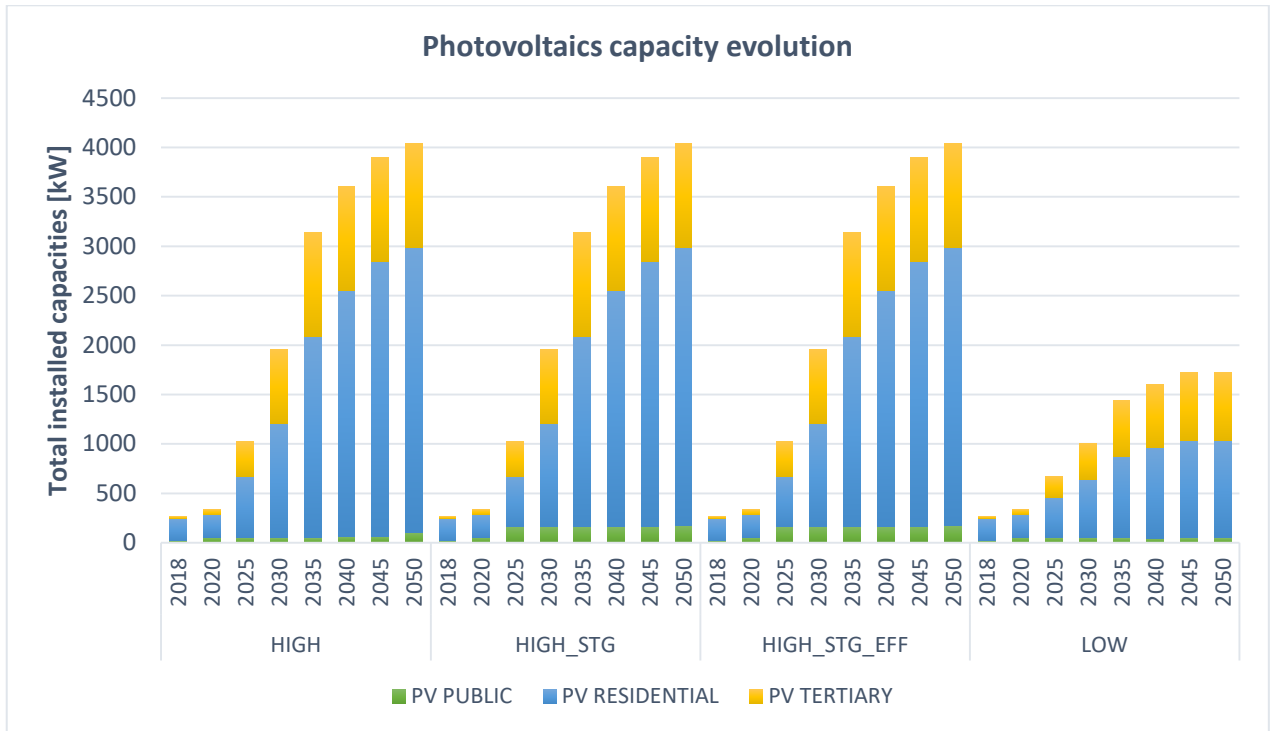

Figure 25. Optimal photovoltaics capacities evolution in the four investigated scenarios

Focusing on storage systems instead, exception made for the Smart Energy Hub (whose installation was forced with a constraint), investments are only made for batteries and in particular the ones for public and residential applications. Long-term storage technologies are not considered despite their lower price per unit of energy. This is probably due to the large conversion losses related to these processes (the efficiency of a charge/discharge cycle is only 37.5%), that makes these technologies energetically not convenient in a context in which local sources electricity production is already quite limited. This is also confirmed by the observation that the rSOC component of the Smart Energy Hub, that the model is forced to install in 2022, is not much used.

The investments are the same in the two scenarios including storage systems (*HIGH_STG* and *HIGH_STG_EFF*). The results, in terms of installed capacities evolution are shown in *Figure 26*. In the case of public buildings, batteries are installed from the first year in which the technology is available. Moreover, the investments are mostly made in the first 10 years of the horizon. On the other hand, for the residential sector batteries are only used through the end of the horizon. This difference is probably related to the cost of public batteries, that are cheaper than residential ones (again due to economies of scale), but also to photovoltaics production with respect to the total load. Indeed, in the case of public buildings an overproduction with respect to the load at peak photovoltaics production hours (midday) when no storage technologies are included in the model (the electricity is in that case injected in the system grid). In general, despite the consideration of the high photovoltaics penetration scenario, storages deployment is not much intensive. The installed capacities are indeed much lower than the maximum amount set as a constraint (about 16.5% and 1% only of the maximum capacity is installed at most in public buildings and residential ones, respectively).

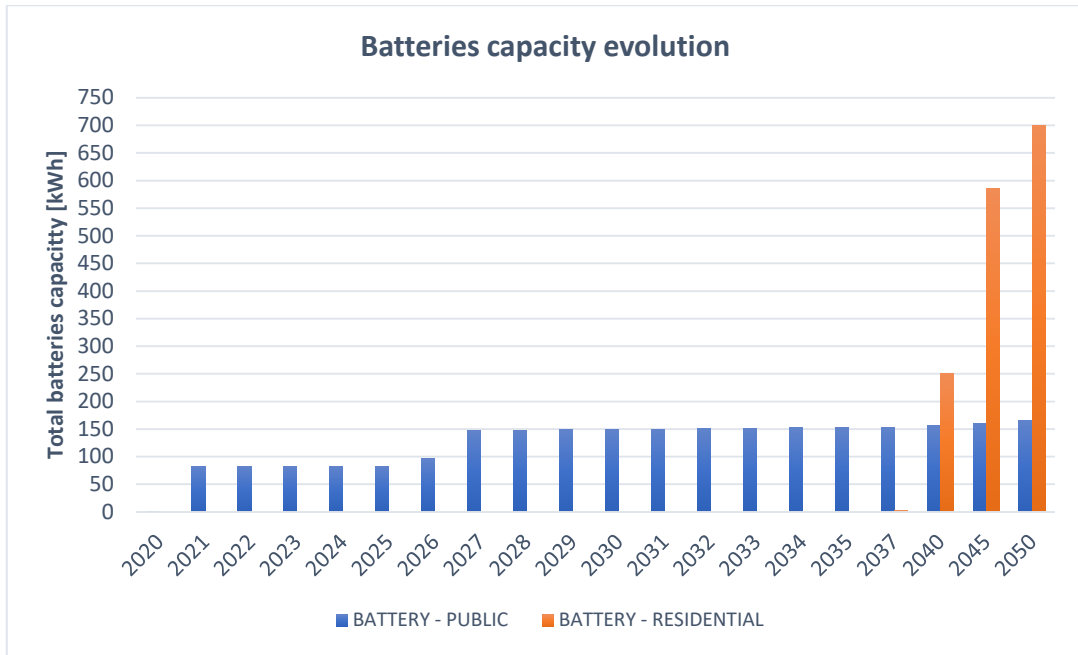

Figure 26. Batteries capacity evolution over the time horizon (HIGH_STG and HIGH_STG_EFF scenarios)

▪ **Renewables share in end-use consumptions**

The main objective of the GIFT project is the decarbonisation of the energy mix of European islands. As the only possible supply solutions are the photovoltaics and imports, there is no CO₂ emissions related to power production and supply in the island. However, important prospective for decarbonisation concern the demand side. It can therefore be relevant to evaluate the possible decarbonisation levels that can be reached with the different photovoltaics deployment scenarios considered for the analysis.

To do so, the renewables share in total end-use electricity consumptions is quantified and compared among all the scenarios. The results are shown in *Figure 27*.

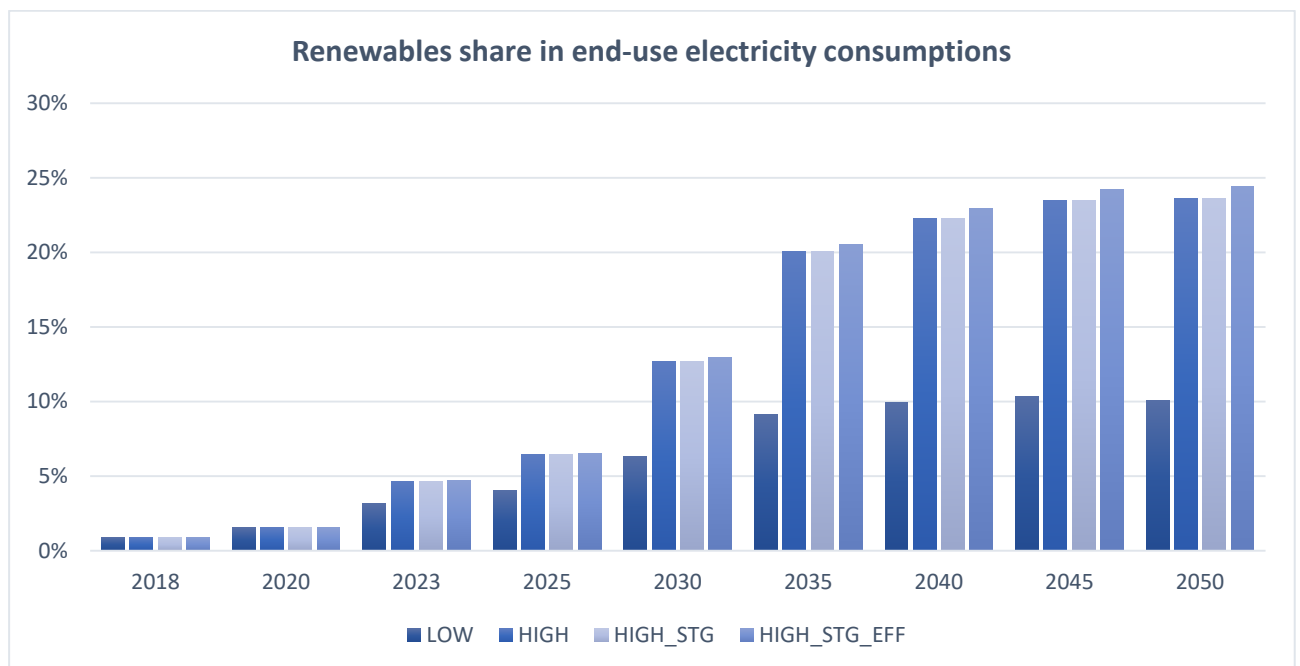

Figure 27. Renewables share in end-use electricity consumptions for different scenarios

Of course, in the high photovoltaics penetration scenarios the renewables share in the end-use electricity consumption is higher. What is relevant to notice though is that especially in the first two decades of the



horizon important improvements in terms of decarbonisation are possible, even with the low PVs penetration scenario (the renewables share, that is less than 1% in 2018, is 10-fold higher in 2040). The decarbonisation possibilities are much more significant with the high deployment scenario, that allows a decarbonisation of about 22.3% in about 20 years. In the last years of the horizon instead the increase is much slower, due to the larger deployment of electric vehicles in the island and the larger annual increase in the electricity demand. There is no difference between the *HIGH* scenario and the *HIGH_STG* one, since the same amount of total PVs investments is made over the time. Moreover, as expected, the scenario with efficiency policies allows increasing the share of renewables in the end-use electricity consumptions.

However, this evaluation is made with respect to the total electricity consumptions of the island. A more refined analysis can be made by focusing on the decarbonisation of the sectors in which photovoltaics are installed¹⁷. The results of this study, made for the *HIGH* scenario, are shown in **Figure 28**. The results are the same for the *HIGH_STG* scenario, as the electricity produced by photovoltaics are entirely used to cover the load of the sector of production. This suggests that a larger share of photovoltaics should be used to appreciate the use of storage systems.

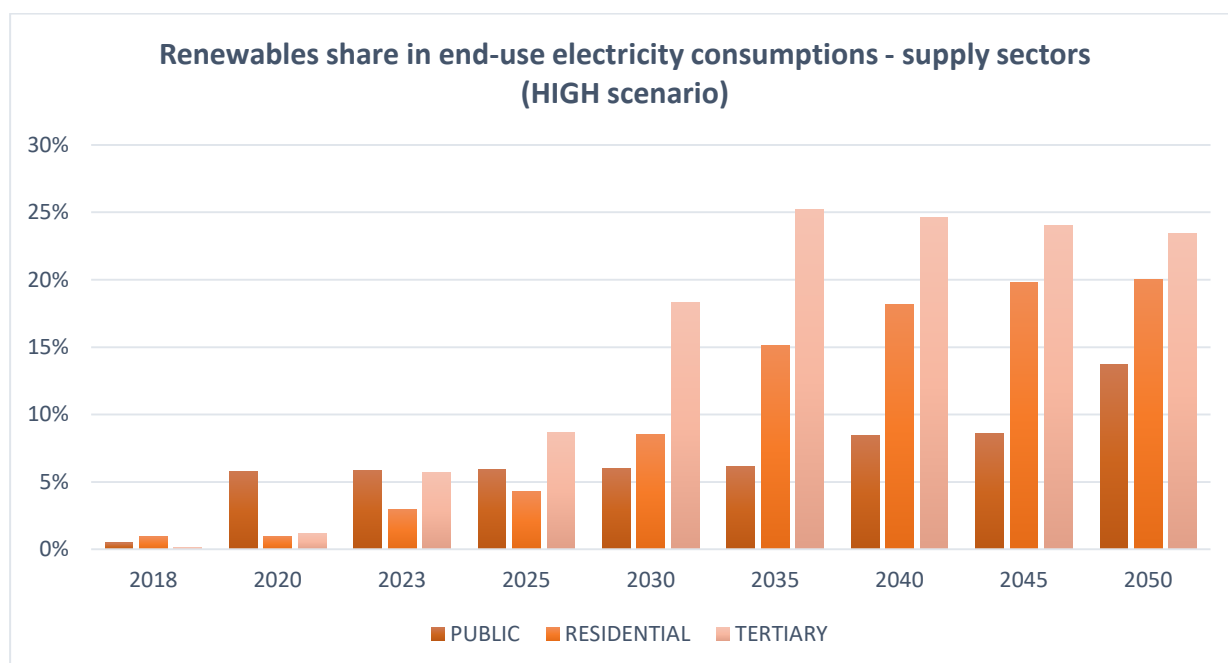

Figure 28. Renewables share in end-use electricity consumptions for supply sectors (HIGH scenario)

The results show that in the optimal solution the tertiary sector is the one that reaches the largest decarbonisation level over the time horizon. The peak is reached in 2035, when the maximum installable capacity is attained; the share decreases thereafter, mainly due to the increase of electricity demand. This can suggest that for this sector, if larger shares of renewables in final consumptions should be attained, additional solutions, such as energy efficiency policies should be pursued.

▪ Imports evolution

¹⁷ For the renewables share in the residential sector consumptions also the demand for transportation sector is included, since it was assumed that EVs are used by residential users and mostly recharged in the evening at home.



As a complement to the analysis, the evolution of the electricity imports over time is examined in the four different scenarios (**Figure 29**).

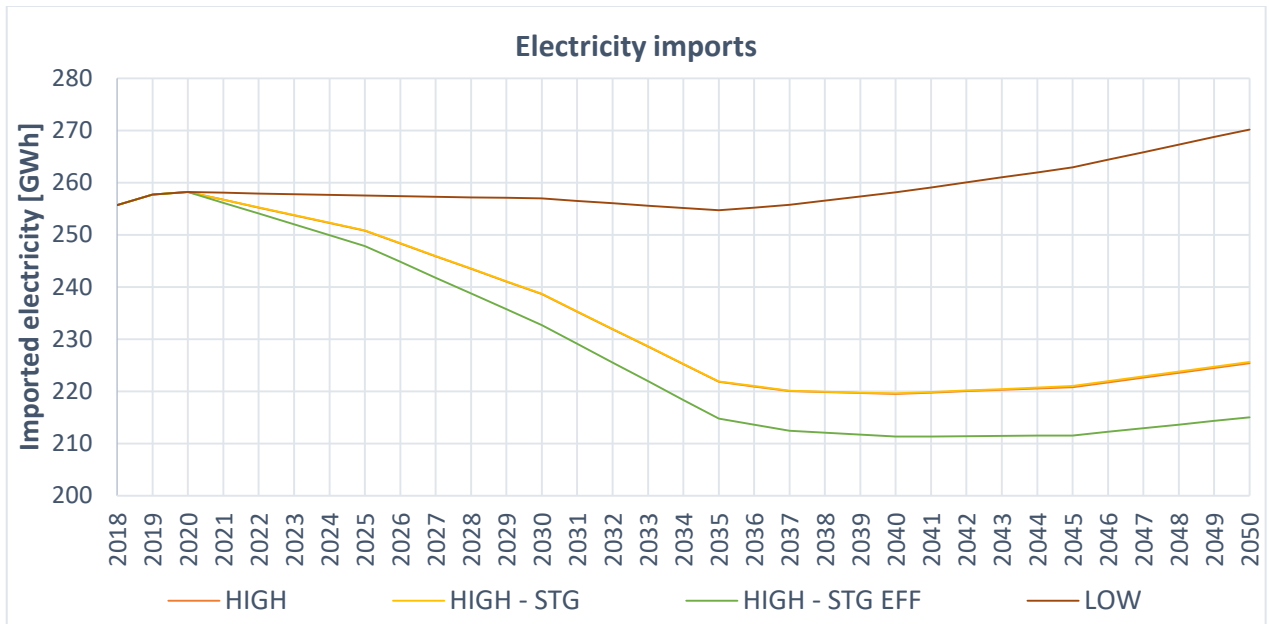

Figure 29. Electricity import evolution over the time horizon

The results show that all the scenarios with high renewables deployment allow a large decrease until about 2035. Later on, as the total electricity demand increases, the photovoltaics do not manage anymore to decrease the dependency on importations despite the installed capacity increases over time. As a consequence, the results suggest that the photovoltaics alone cannot guarantee the decarbonisation of the island on the long-term. Energy efficiency policies could contribute to limit the imports, even if the ones considered for the scenario seem not to be enough to prevent from the imports increase in the last years of the horizon. No imports reductions can instead be detected in the scenario with storage deployment.

▪ **Storage technologies**

At a first sight, the results obtained for the renewables share in final consumptions and the imports seem to suggest that the use of storage technologies does not significantly foster the increase of renewables. However, a closer look at the results can show the benefits of these devices on the energy system of the island.

At a system level, one of the main advantages is the grid congestion relief at peak hours. Indeed, the results show that the use of batteries allows decreasing the electricity imports at peak hours, when the grid is more subjected to congestion problems. The comparison between the scenario with high renewables development with and without storage technologies in terms of imports at peak hours in Procida is shown in **Figure 30**. In this case the decrease is quite low (-0.61% at most), since the investments on batteries obtained with the optimal solution are not much. However, the results could probably be more significative if requirements related to grid congestion relief are integrated in the model or in cases of larger renewables penetration, as in this case a larger amount of energy produced by photovoltaics could be shifted from high production hours (midday) to no production hours (especially in the evening, when the peak of demand occurs). Moreover, care should be noticed that a better estimation of the seasonal consumptions shares, that considers the load increase in summer, could result in a higher deployment of storage technologies, as a higher electricity production is possible during this season.

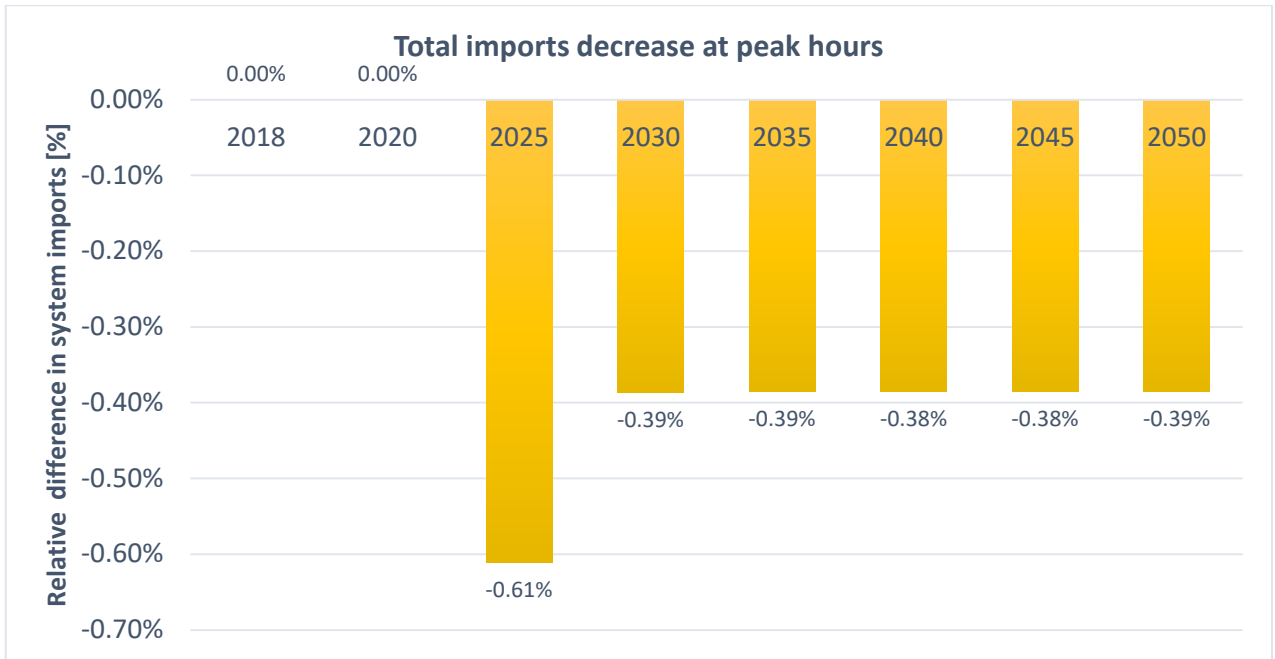

Figure 30. Effect of storage on electricity imports at peak hours

Another advantage is related to the possibilities of self-consumption. Considering public buildings, that are the ones in which the most important investments on batteries are made in the model, the results show that the use of batteries enables to decrease the electricity imports up to about 55% (in 2035, see [Figure 31](#)). This implies important economic advantages for the users, as well as advantages for grid congestion relief and grid flexibility, especially at peak hours, as the grid has to manage a lower amount of electricity flows (the improvements noticed at system level are probably mostly due to the public sector).

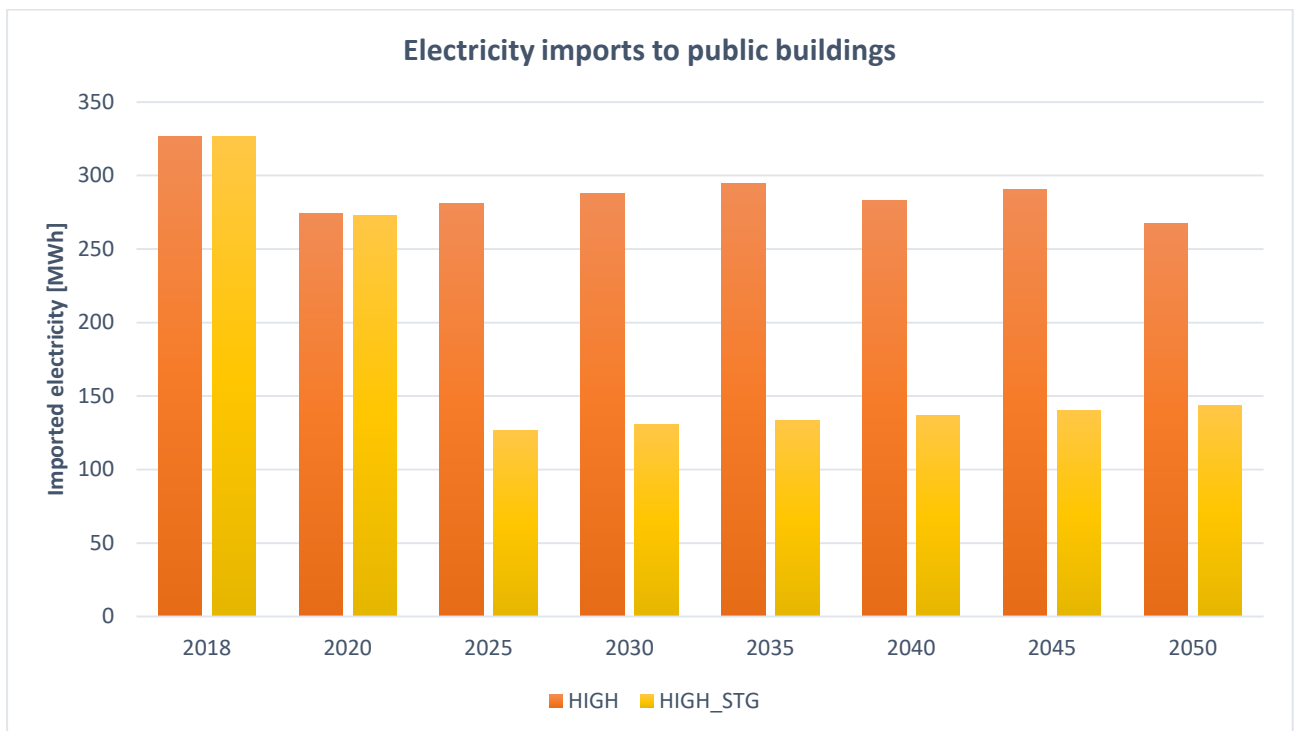

Figure 31. Effect of storage on public buildings electricity imports



- **V1G scenario**

Finally, another simulation has been carried out in order to include additional flexibility solutions in the demand side in the *HIGH_STG* scenario. In particular, a V1G scenario has been considered.

The V1G is a flexible solution that could be used by DSOs to better manage the electricity load due to electric vehicles that are connected to the grid. It consists in a modification in the recharge profile of a part of the EVs that is made through a modification of the input current that feeds the vehicle. In this way, it is possible to decrease a part of the demand of EVs that occurs at peak hours by shifting this load in off-peak hours. In the model, this is made by estimating a new load profile that assumes 70% of the users that are charging the vehicle at peak hours (evening) are participating in the V1G program. Moreover, it is assumed that the V1G can be made starting from 2025. The calculation used to estimate the new load is detailed in section 9.4.5. The new daily load profile, that is obtained by considering a load shift from evening hours to night ones, is shown in **Figure 32**.

The results of the simulation are not different from the ones obtained for the *HIGH_STG* scenario in terms of renewables share in final consumption (and therefore also in terms of savings in imports). This confirms that the electricity produced by photovoltaics is only used in the sector it is produced, and therefore that the share of VREs integrated in the energy system is not high enough to appreciate the advantages of shifting the load to off-peak hours. As in the case of storage technologies, this practice could result more effective if grid reliability requirements were introduced in the model.

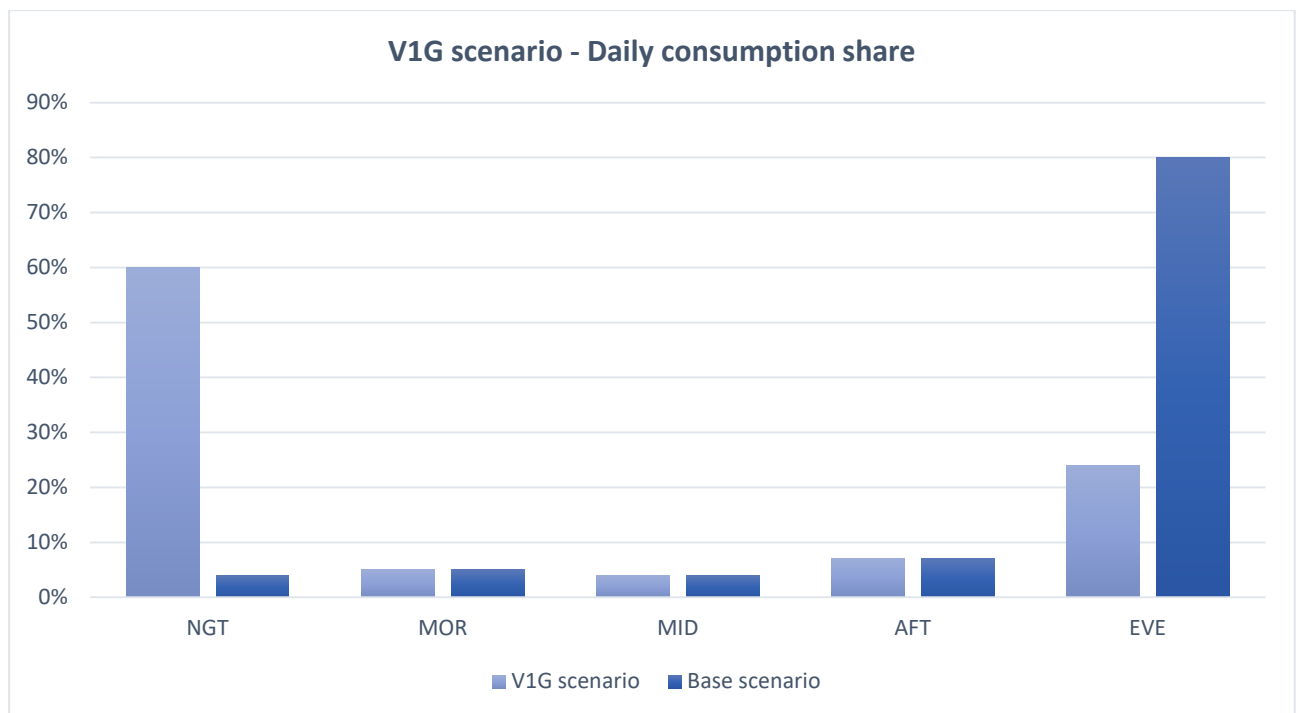

Figure 32. Comparison between the daily consumption share in the base case and V1G scenario (electric cars)



The results obtained with the TIMES-Procida model configuration allow to draw several conclusions. The results obtained considering different realistic renewables' integration scenarios show that promoting the use of photovoltaics in the island could lead to important improvements both in terms of costs, energy independence of the island and grid congestion relief. Improvements could be detected even in cases of low renewables deployment, suggesting that the energy system could benefit from the policies supporting local energy production. However, the results also showed that in the long-term the use of photovoltaics alone is not enough to cope with the increase of electricity consumptions. Additional solutions should then be considered, such as policies supporting energy efficiency.

This analysis also attempted to evaluate the potential benefits coming from the use of the flexibility solutions integrated in the model. Concerning storage solutions, the results showed that the use of these devices is strictly related to the amount of renewable energy integrated in the energy system, as the investments in these devices increase with the share of photovoltaics. From the economical point of view, investing in storage solutions seems not attractive as the total system cost remains quite the same. As in the case of low renewables' integration in the system storage is not invested in the model solution; it also suggests that there exists a lower limit over which storage becomes competitive. The only investments on storage solutions concern electricity batteries, probably due to the fact that seasonal storages present high energy losses that make their deployment inconvenient in an energy system with scarce possibilities of local production. Nevertheless, these technologies result a valid solution when considering the energy system as a whole. Indeed, improvements with regard to grid congestion relief and self-consumptions can be observed even when limited investments in these devices are made. The improvements could be much more relevant when higher shares of renewables are integrated in the power system. At higher shares even other flexibility solutions, such as the V1G, could result more effective.

It is however important to notice that these results are subjected to different limitations. The most important one concerns the assumptions made to cope with the lack of information about the energy system of the island. In fact, the energy use by sector is not reflected in the available data and consequently assumptions were made on Italian statistical values, that differ from the local context of the island. This did not allow to properly represent the seasonal variation in electricity consumptions, that in Procida represent a major issue. Integrating more representative data may lead to different investment choices for the flexibility solutions, as for example in the case of the seasonal storages. Additionally, it is relevant to mention that the model is based on an economic optimization approach. The investment decisions are then influenced by economic considerations, whereas technical aspects such as flexibility requirements to ensure the reliability at peak hours are not included. These requirements are however dependent on the information about the consumptions and congestion problems during summer.

In conclusion, the analysis showed that ensuring the decarbonisation of the island is possible, but for this scope other solutions are needed (e.g. efficiency, storage technologies or other flexibility solutions when high shares of renewables are included in the power system). However, improvements to better define the energy system of the island should be made.



7. LONG-TERM DISCUSSION ON HINNOYA ISLAND CLUSTER

7.1. DEMONSTRATION SITE: THE NORWEGIAN LIGHTHOUSE

7.1.1. Main territory aspects

Hinnøya is the fourth largest island in Norway, with a surface of 2,204 km² and 32,000 inhabitants. Administratively, the island is composed by eight municipalities (Andøy, Hadsel, Lødingen, Sortland, Tjeldsund, Vågan, Harstad, Kvæfjord). Harstad is the most populous city on the island. The geographical location of Hinnøya is shown in Figure 33.

The Municipality of Harstad does not only contain parts of the main island of Hinnøya, but also other smaller islands which are situated at the outskirts of the Harstad city such as: Grytøya, Bjarkøya, Sandsøya, Helløya, Flatøya and Krøttøya and many even smaller islands.

The **Hinnøya island cluster** includes the islands of Hinnøya, Grytøya, Bjarkøya and Sandsøya.



Figure 33 : Hinnøva's location

7.1.2. GIFT Specific objectives

The solutions developed by the GIFT project will be installed in a specific island that is under the Harstad Municipality, that is Grytøya (located in the north of Hinnøya). This island has reached its full capacity in terms of connections to the network, thus new applications are currently rejected by the local Distribution System Operator (DSO). Among these rejected users there are fish farms, that are one of the main consumers in the island. Consequently, these fish farms are highly dependent on diesel generators. Concerning transports, the second major source of pollution, the Municipality is considering the introduction of new means of transportation, such as electric ferries, to decarbonise the sector.

In this context, the GIFT project aims to integrate flexibility solutions to support the decarbonisation of the island. In particular, the solutions involve demand-side management measures for fish farms, e-ferries, e-vehicles, harbours, as well as stationary storage technologies, among which an HBr flow battery installed at distribution level. These solutions would allow deferring investments into transmission grid and simultaneously supporting the local electricity production from renewables.

7.2. THE NORWEGIAN ELECTRICAL SYSTEM

7.2.1. Energy production and consumption

7.2.1.1. Energy production

The Norwegian electricity production mix is dominated by renewable energy sources with more than 95% originating from hydropower alone, and it is the largest share in continent Europe.

The installed total capacity is 33.8 GW with a total electricity production of 143.9 TWh (IEA, 2019). Hydroelectric power accounts for a large part of the total annual production with more than 1,660 hydroelectric power plants installed and a 96% share of installed capacity (IEA, 2019). Thus, production is largely determined by water inflows and installed capacity.

The seasonal and yearly variation of water inflows is very significant. The inflow is not in phase with the power demand in Norway with the inflow being high during summer and low during winter while the power demand is peak during most of the winter periods. The large reservoir hydropower plants, however,



with a total storage capacity of 86.5 TWh could provide the peak demand during winter periods, which corresponds to 70% of the total annual electricity demand. The storage facilities are thus a major source of the flexibility in the Norwegian electrical energy system, allowing electricity to be generated even when precipitation and flows are low, by balancing the demand and inflows. The flexibility is achieved at several scales. Usually small reservoirs are used to balance load fluctuations in a short term while large reservoirs are used mostly for seasonal balancing following the electricity price pattern.

The total wind power installed capacity is around 3.97 GW which accounts for approximately 10.53% of the total installed capacity, while thermal power plants accounts for 1.85% (NVE, 2021, 2020). Thermal power plants are mainly used in large industrial installations generating their own electricity (Energifaktanorge.no, 2019). Nevertheless, despite the high installed capacity utilisation and production in Normal precipitation years and/ or wet years, in dry years and/or winter periods, the available capacity represents around 80% of the total installed capacity and forced to import electricity to balance the deficit through the regionally integrated Nordpool electricity market (IEA and OECD, 2017).

7.2.1.2. The consumption

The share of electricity in the final total energy consumption in Norway (46%) as well as its per capita consumption of electricity (22 600 kWh) is the highest in Europe (IEA and OECD, 2017). The industrial sector is the largest electricity consumer (especially aluminium production), followed by the residential and service industry sector. The two latter have had an increasing share in total consumption over the last few years. The annual peak demand is typically found during winter, especially in January with an average power demand of 24 GW. Electricity consumption in the transport sector is increasing due to the extended incentives for electric vehicles in Norway. Nevertheless, the share of electricity in transportation remains relatively small but expected to increase in the years to come (NVE, 2016).

7.2.1.3. The electricity grid

Since the sources of production are often located far from the sources of consumption, the grid plays a key role in the transmission and distribution of electricity to the various consumer groups.

The Norwegian electricity grid is divided into three levels:

- The high voltage main transmission network connects large producers and consumers at the national level and connects Norway to neighbouring countries. The voltage ranges from 300 to 420 kV, and 132 kV in some parts of the country. Statnett is the main operator of the transmission network (IEA and OECD, 2017).
- The regional transmission network links the main transmission system and the regional distribution system. The voltage ranges from 33 to 132 kV. The largest consumer groups (electro-intensive or petroleum industries) are directly connected to the transmission grid.
- The regional distribution network operates at the local level by municipalities and counties and supply low voltage electricity to various small consumer groups such as residential customers. The voltage is up to 22 kV. Small producers are usually connected to the regional distribution grid.

Norway is planning to upgrade the existing 6.3 GW its interconnection capacity with continent Europe to 9.1 GW by 2021.

7.2.2. The Nordpool electricity market

7.2.2.1. Trading markets

Norway introduced a deregulated electricity market in 1991. Currently more than 90% of electricity trade is through NordPool electricity market. It is one of the largest electricity markets in Europe that comprises of Norway, Sweden, Finland, Denmark, Estonia, Lithuania and Latvia. For an optimal running of the market, the regulatory frameworks are harmonised between the different countries.

The NordPool electricity market is normally divided into two physical markets:



- Elspot: It is a day-ahead electricity market where most of the trade is taking place. Producers and consumers/wholesalers make offers and bids on the market specifying how much they are willing to supply and buy and at what cost. The TSO is therefore responsible for calculating a balance that sets the market price and determines the capacity required at hourly intervals for each producer the next day. This market is also coupled with the day-ahead markets of other European markets.
- Elbas: It is an intra-day market used to balance production or consumption variations after the closure of the day-ahead market, thus maintaining the balance with continuous trading.

Normally the Elspot and Elbas markets would allow the smooth functioning of system balance but in certain unforeseen events that disrupt the system balance, Statnett uses service systems and adjustment mechanisms to regulate consumption upwards or downwards according to its needs in order to maintain the reliability of the network, particularly to control the frequency.

7.2.2.2. Market clearing prices

In a perfect competitive market, the market clearing equilibrium price is determined at the intersection of the supply and demand curves or the price that all bids and offers are completely traded. Since Norway's trading capacities are significant, the prices in Norway tend to be influenced by the high production costs of thermal-dominated market regions, i.e. oil, coal and/or gas-based power plants as much as the high hydropower production in Norway and Sweden tends to lower electricity prices in thereof.

However, in addition to this pricing system used on NordPool, there are regional prices which consider congestion on the network and allow for balancing between the different auction zones. Thus, there are 5 auction areas in Norway.

This price gap between regions is the result of disparities between the territories' energy situations. When electricity has to be transmitted from one region to another, congestion may occur if there is insufficient grid capacity. The price is higher in areas where there is a deficit and electricity is therefore transmitted from low price areas to high price areas. In addition to providing a balance, these prices also indicate where there is a need to vary production or consumption in the short term, and where the need for new capacity is located in the long term.

7.2.2.3. Electricity retail market

The electricity retail market in Norway is highly competitive, and is one of the most competitive markets in Europe after Finland, Sweden and the United Kingdom (IEA and OECD, 2017). Indeed, the market share of the three largest suppliers is below 40%. There are no regulated prices for consumers except in very special cases. Consumers can choose different contract options either with a fixed price, variable prices or market prices (60% of consumers have this option).

The price of electricity for final consumers is composed of: the price of electricity, the grid tariff, the electricity tax, the value added tax, as well as a payment for the Energy Fund (Enova) and electricity certificates.

Table 4. Electricity prices for households in 2018 (ssb.no, 2019).

Electricity price before tax (€/kWh)	Electricity price after VAT ^{18,19}	Grid tariff before tax	Grid tariff after	Total price (elec. + grid) before tax	Total price (elec. +	Tax on electricity consumption	Value Added Tax

¹⁸ NOK (Norwegian krone) = 100 øre ≈ 0,10 €



	(€/kWh)		tax	(€/kWh)	grid after tax (€/kWh)	(€/kWh)	(%)
0,0486	0,0593	0,0287	0.0556	0.0773	0,1149	0.0166	25

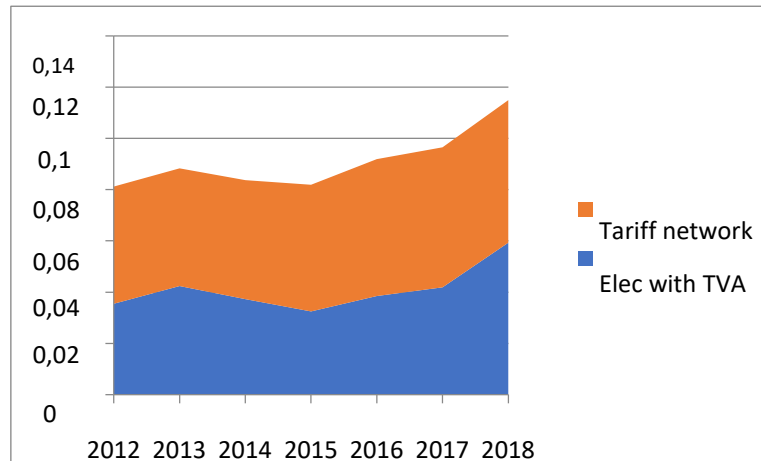

Figure 34 - Evolution of the electricity price for households in €/kWh (SSB, 2019)

7.2.3. The regulatory framework

7.2.3.1. The main actors

Norway is part of the European internal energy market through the European Economic Area Agreement (1994). Originally, European energy policy was mainly focused on creating competition in European energy markets. Today, notably through the Lisbon Treaty of 2009, a stronger supranational framework has been put into place by setting targets or guidelines on the functioning of the energy market, security of supply, energy efficiency or the development of renewable energies. The country is therefore strongly influenced by European directives on energy policy.

- Ministry of Petroleum and Energy

The MEP is responsible for energy policies and water resources management and must ensure that management in the sector is in line with the guidelines of the government and of the Storting (sole chamber of the Norwegian Parliament).

- The Norwegian Water Resources and Energy Directorate

The Directorate operates under the authority of the MEP and is responsible for the management of the country's energy resources. In particular, it is responsible, among other things, for issuing licenses for the installation of new capacities and for maintaining the safety of installations, especially dams. The Directorate is the national expert in hydraulic matters.

¹⁹ Since 1 January 2004, the tax on electricity consumption has been collected by the grid operator. As a result, the tax on electricity consumption is included in the electricity price before 2004 and in the grid tariff after that date. Consumption tax is not collected in Finnmark and in some municipalities in the North Tross, Nordland, Tross and Finnmark do not pay VAT.



However, its main activity is to act as the regulator of the energy sector in Norway.

- Statnett

Statnett, a public company, is the Norwegian network operator. It is responsible for managing the high-voltage transmission network (of which it owns 90%) and operating on the network from a national control centre and three regional control centres.

- Enova

Enova is a public company which provides funds and policy advice for energy and climate projects. Its objective is to promote more environmentally friendly consumption and the development of clean energy technologies.

There are also other actors indirectly linked to the energy sector but whose role is essential, including the Norwegian Research Council, which manages the energy R&D funding allocated by the ministries, the Ministry of Finance, which is responsible for economic policy, the Ministry of Climate and Environment, which is responsible for achieving the national climate objectives set by the European Union, and finally Statkraft SF, a public company of the Ministry of Trade, Industry and Fisheries which owns most of the country's hydropower plants.

7.2.3.2. The legal framework

The Norwegian legal energy framework aims to consider and harmonize the interests of the various economic actors and environmental issues, on the one hand, and to ensure efficient resource management and the proper functioning of the system, on the other hand.

- Waterfall Rights Act

To be able to produce hydroelectric power, a private agent must hold a license (except for small farms). The objective is to ensure that water resources are managed in the interests of the country. In practice, today these licenses are only issued to public entities such as public companies, municipalities or regional authorities, and companies' two-thirds owned by one of the latter two entities.

- Watercourse Regulation Act

In order to regulate flows between the various watercourses and the transfers between them for electricity production, a license must be obtained for run-of-river power plants generating more than 40 GWh per year. In addition, these licenses impose minimum and maximum water levels for tanks and may include obligations to sell electricity.

- Energy Act

Norway's energy policies are mainly governed by the Energy Act (1990). Its objective is to ensure that energy is produced, transmitted, exchanged and used in a rational manner and for the common good. The Energy Act is behind the deregulation of the electricity market.

Since the development and management of the network is a natural monopoly, it provides a legal framework for regulating these activities. It also regulates marketplaces and foreign trade. In addition, through licensing, it allows the installation of new capacities such as wind farms and transmission lines, and distribution operators must also hold a license to operate within a region.

For the electricity market, the national authority in charge of its application is the NVE.

7.2.3.3. Measures in favour of renewable energies & emission reduction

By 2020, Norway aims to reduce its greenhouse gas emissions by 30% compared to 1990 levels (Norwegian Environment Agency et al., 2017) and by 40% by 2030. In addition, the country wishes to reach carbon



neutrality by this date. Finally, by 2050, Norway aims to be a low-emission country with an 80-95% reduction compared to 1990. Report 13 (2014-2015), "New emission obligation for 2030 - a common solution with the EU", sets the following emission requirements:

- Norwegian climate policy aims to contribute to reducing emissions at home and abroad, so that an increase in the global average temperature does not exceed 2 degrees. The objective is to reduce emissions by at least 40% of 1990 emissions by 2030.
- The long-term goal is to make Norway a low-emission society by 2050.

These objectives are now written into the Climate Change Act, which came into force on January 1, 2018. The Act aims to promote the implementation of Norway's climate change objectives as part of the transition to a low-emission society in 2050. The target of a 40% reduction in emissions by 2030 is also the target part of Norway's obligations under the Paris Agreement. Thus, the cornerstone of Norwegian emission reduction policies, as highlighted in (Norwegian Ministry of Climate and Environment, 2017), is the emission allowance trading market and taxes which between both of them cover 80% of the country's emissions.

CO2 taxes were introduced in 1991 in the offshore oil and gas sector, the transport sector and the heating sector. In 2018, the tax is 500 NOK per ton, and the State plans to introduce by 2030 a flat-rate tax on emissions which are not part of the European Trading System.

In 2005, Norway introduced a national emissions trading scheme covering 11% of national emissions. In 2008, the country joined the European Emissions Trading Scheme, which now extends emissions coverage to 50%.

In addition, Norway participates in the Clean Development Mechanism through Certified Emission Reduction Units. These credits or allowances are granted when emissions are reduced by one ton of CO2 equivalent and can be bought or sold on the market.

"Every person has the right to an environment that is conducive to health and to a natural environment whose productivity and diversity are maintained. Natural resources shall be managed on the basis of comprehensive long-term considerations which will safeguard this right for future generations as well. In order to safeguard their right in accordance with the foregoing paragraph, citizens are entitled to information on the state of the natural environment and on the effects of any encroachment on nature that is planned or carried out. The authorities of the state shall take measures for the implementation of these principles."

The Constitution stipulates that the authorities must implement measures to ensure that nature's resources are preserved overnight. He also stressed that informing citizens is important.

- Climate and energy planning for municipalities

The plan "State Planning Guidelines for Climate and Energy Planning in Municipalities" of September 4th 2009 provides the following guidance for climate planning in municipalities:

- All municipalities must have an energy and climate plan or an energy/climate part in their municipal plan.
- The plan should include information on the municipality's greenhouse gas emissions, emission reduction targets and the measures for more efficient energy use and environmentally friendly energy conversion.
- The plan must be launched every 4 years.

- Electricity certificates

The electricity certificate system was introduced in 2012 together with Sweden. The objective is to promote the increase of electricity production from renewable sources.



An electricity certificate is a label issued by the State ensuring that one MWh has been generated by a renewable source.

All producers and some consumers are forced to buy certificates for a certain percentage of their production (or consumption). This percentage is gradually increased until 2020 before decreasing until 2035 when the system is withdrawn. The idea is to create a demand for these certificates so that they acquire value (determined by the market) and renewable electricity producers receive income from these certificates.

The objective is to encourage the production of renewable electricity and, in the long term, to increase its share in the Norwegian and Swedish mixes.

- Development of electric transport

Norway is a world leader in electric vehicles. Indeed, in 2016, they already represented 29% of new cars sold, with a market share of 6.3%, 75% of which are pure electric vehicles (different from other countries where hybrids are more common) (IEA and OECD, 2017)

The progress in sales of electric vehicles in Norway is linked, on the one hand, to technological progress for batteries with higher storage capacities and reduced costs, and on the other hand, to strong political incentives. Indeed, the Norwegian Parliament has set a target of limiting CO₂ emissions for new vehicles to an average of 85gCO₂/km by 2020 (in comparison, Europe has a target of 95 gCO₂/km by 2021), and expects new vehicles sold by 2025 to be only zero emissions vehicles.

As a result, Norway has set up a system to promote electric vehicles that includes both financial and non-financial incentives (with stronger incentives for pure electric vehicles than for hybrids, which explains their dominance).

Zero emission incentives for electric vehicles still in place today include (elbil.no, 2019):

- No registration fees (1990-)
- No annual road tax (1996-)
- Exemption from VAT on purchase and leasing up to 25%.
- Introduction of charges on toll roads and ferries with an upper limit of 50% of the total price (2018)
- Access to bus lanes (2005)
- Authorization for local authorities to limit access to areas by accepting only electric vehicles (2016)
- Reduction of the tax on professional vehicles to 40% (2018)
- Financial compensation for any change from an ICE van to a zero-emission vehicle (2018)
- Authorization for drivers with a B license to drive electric heavy vehicles (class c1) up to 2,450 tons (2019)
- An upper limit of 50% of the total price for parking taxes for electric vehicles (2018 - free from 1999 to 2017)

The Government has chosen to maintain these incentives until 2021, after when they will be revised to adjust to market development.

Since charging infrastructure is a key element in the development of electric vehicles, the installation of the 10,000 public charging stations has received strong financial support from the government and municipalities. In addition, the government has put in place a program to finance the installation of at least two rapid charging points every 50 km on main roads.

Thus, the idea of successive governments in Norway has been to make electric vehicles competitive with conventional vehicles. This has been achieved by introducing the "polluter pays" principle by exempting zero emission vehicles from taxes and imposing heavier charges on the most polluting vehicles.



In addition, in order to alleviate congestion on the roads, Norway has also put in place programs for the development of public transport. There is therefore a growing phenomenon of electrification of bus lines, but also of public ferries, which are now required to use low-emission technologies.

7.3. TIMES-HINNOYA MODEL DEVELOPMENT

The use cases of the GIFT projects are implemented and explored in a long-term energy system development perspective. The objective function minimizes the total discounted system cost for the entire model horizon (2015-2050) making investments and operational decisions at each period or year of interest at a given general discount rate (d); in this model a general discount rate of 6.5% is used. This rate is also used to shape the capacity depreciation level of all investments (NTNU, 2020)²⁰.

7.3.1. Model horizon and tempo-spatial representation

7.3.1.1. Timeslices

The temporal resolution is formed by an aggregation of similar load pattern periods and called timeslice. According to the technologies existing energy system of Hinnøya, the demand and supply dynamics in addition to the characteristics of energy commodities and last but not least the data availability, the timeslices are sorted in the below structure. The three levels that were input in the TIMES model are specified in seasonal level as the twelve months of the year (representing winter, spring, summer and autumn fluctuations). Monthly is a parent timeslice for weekly (the five working days are represented by WD and the weekend by NWD), and subsequently, weekly to daynite timeslice. In general, hence the time resolution is high with 576 time- steps representing a year; $12 \times 2 \times 24$ which helps capturing supply and demand dynamics.

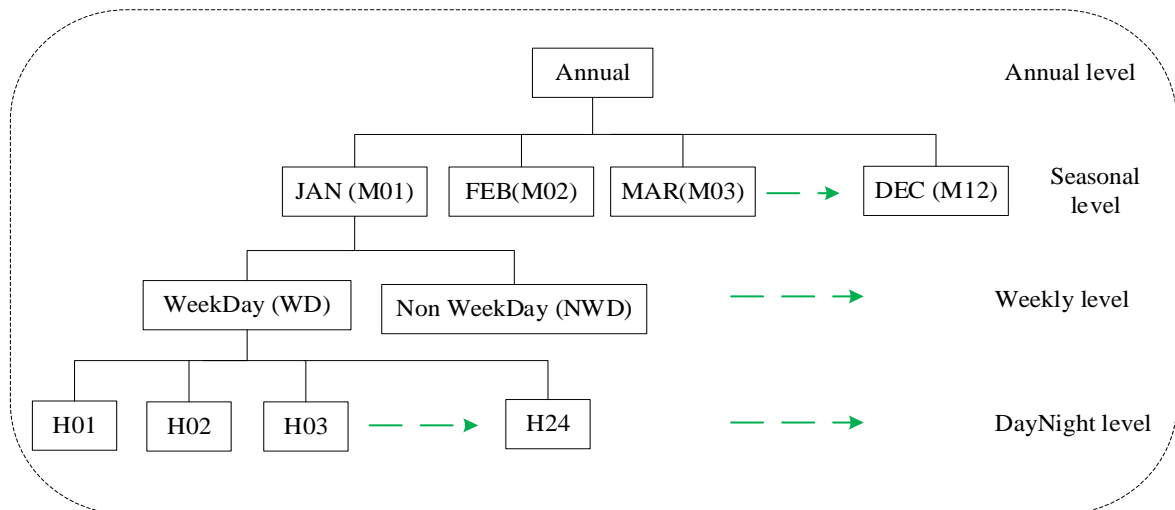

Figure 35 - Temporal representation of the model (NTNU, 2020)

7.3.1.2. Regions

The TIMES-Hinnøya model is spatially calibrated by three regions: Harstad, the remaining Hinnøya, and Grytøya, in that way it represents the Hinnøya island cluster considered in GIFT project. According to NTNU, 80% of the settlement is in Harstad city alone and the use cases have explicit interaction with Harstad city and Grytøya.

²⁰ This analysis was conducted using the TIMES-HINNOYA model developed by NTNU (Lizhen HUANG, Dejene Assefa HAGOS Wenji ZHOU and Yongping LIU), to which we then integrated GIFT technologies.



In Figure 36, we see the spatial representation of the TIMES-Hinnøya model with its interaction with the electricity market NO4 of Nordpool since the island is completely located in this region. Based on this, the model allows to trade electricity with thereof with a maximum capacity of 700 MW. The connection between Harstad and Grytøya is 3-4 MW, and were included in the model accordingly. There exists also a connection between the Rest Hinnøya and Grytøya, but the exact capacity is not known yet, and hence, it was assumed to be 3-4 MW in this case also.

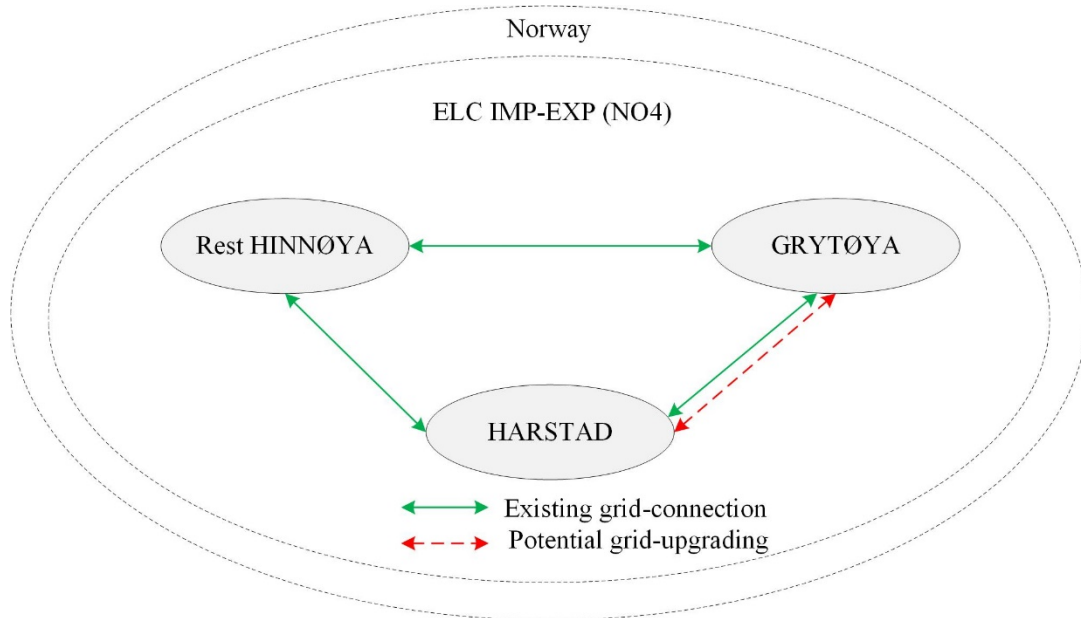

Figure 36 - Geographical representation of the model (NTNU, 2020)

7.3.2. Base year energy system

7.3.2.1. Energy Supply

Electricity is the main energy commodity in the reference energy system as it is in whole Norway. Electricity make up more than 61% of the total energy supply while transport fossil fuel makes up 30%, non-transport fossil fuel 4%, and wood-based resources 5%. (NTNU, 2020)

The diagram below shows the repartition between the energy commodities of the energy mix of the Hinnøya cluster island in 2015 as per data provided by (Zhou W. and Assefa Hagos D. et al., 2020)

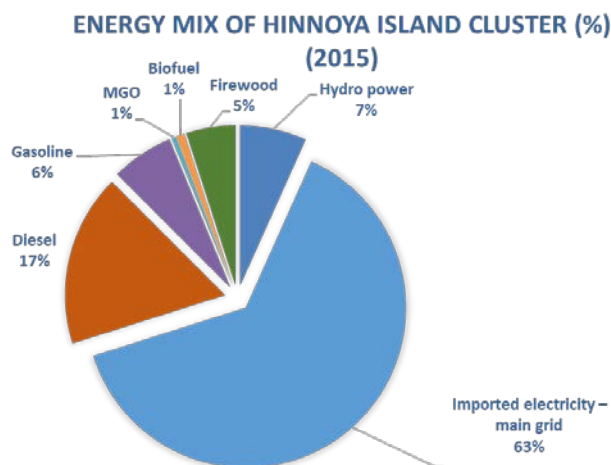

Figure 37 – Energy mix of Hinnøya island cluster in 2015



As seen in the diagram, hydropower exists on the island cluster representing a total of 18.35MW installed capacity run-of-river (ROR) (3.95 MW in Harstad and 14.4 MW in remaining Hinnøya). The annual capacity factor of the ROR hydro plants in Harstad is 53% while in rest Hinnøya is 47%. As for the electricity imports, the 700 MW grid connection within the electricity market region NO4 would balance the demand and supply in the island as explained in section 7.3.1.2

7.3.2.2. End-use demand

On the demand side, the sectors modeled are the residential, industry (primary, secondary, tertiary), and transportation. Details about these sectors and their load profiles by timeslice and season for the base year of the model are presented in the Annex II. The total energy demand by energy source is shown in Table 5. Since the electricity demand is met at a large extent by the hydro dominated power system of Norway (95% hydropower), transportation is the main source of GHG emissions in the island. The electricity demand and its diurnal pattern are modeled exogenously as input parameters.

Table 5 - Total energy demand in Hinnøya by energy source in 2015 (TJ).

Fuel	Harstad	Rest-Hinnøya	Grytøya
Electricity	1439	938	27
Fossil fuel in transport	719.51	469	13.51
Fossil fuel in non-transport	100.73	65.66	1.89
Wood	115.12	75.04	2.16

The main economic sectors on the Hinnøya island cluster are using the electricity from the grid for their processes. The consumption repartition by sector shows that the residential sector is the biggest consumer of electricity, this is due mostly to the heating of households. It is followed by the services sector which activities include storage of wholesale food, grocery stores and tourism activities.

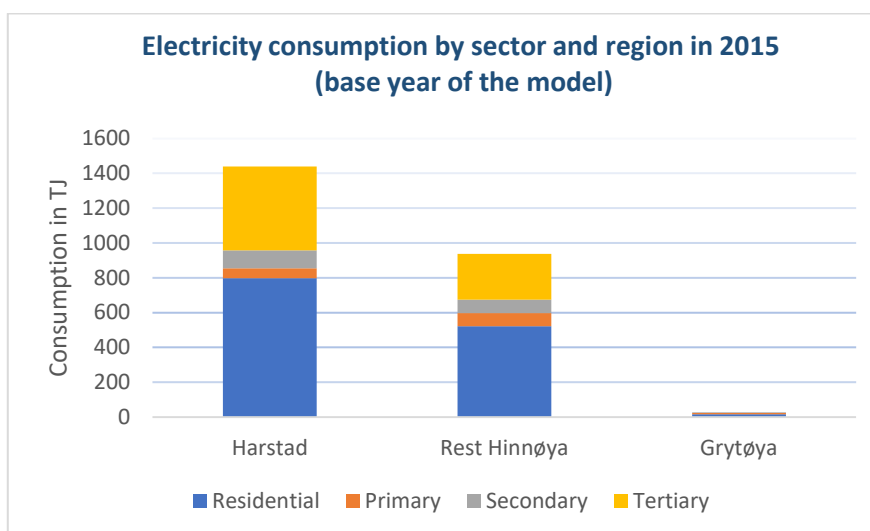

Figure 38 - Electricity consumption by sector and region in 2015



As for the fish farms that are concerned within the GIFT project, they are represented in the region of Grytøya as demand appliances and their consumption of electricity through diesel supply is separated from the other sectors. The fish farms' demand is 2.28 TJ in year 2015 (NTNU, 2020) and accounts for 7.8% of the electricity needs of Grytøya and 25% of the primary sector electricity consumption.

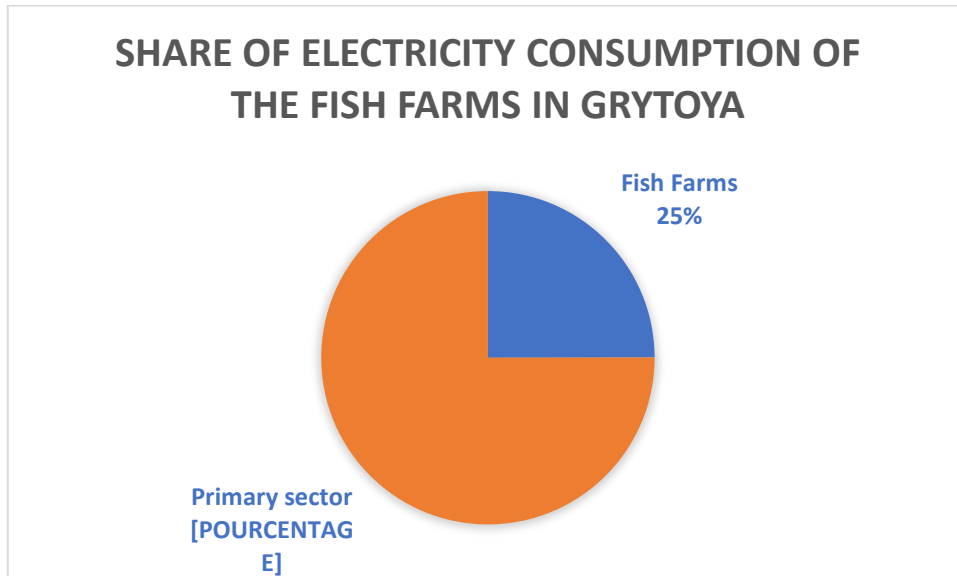

Figure 39 – Share of electricity consumption of the fish farms in Grytøya

7.3.2.3. Base year model structure

The final base year model structure is found in (Zhou W. and Assefa Hagos D. et al., 2020) it represents the distribution of the different components studies in the energy system. We can see that the fish farms are separated as industry so that they reflect the according use case. In the model, we find them only represented in Grytøya since they are located off-shore near this island.

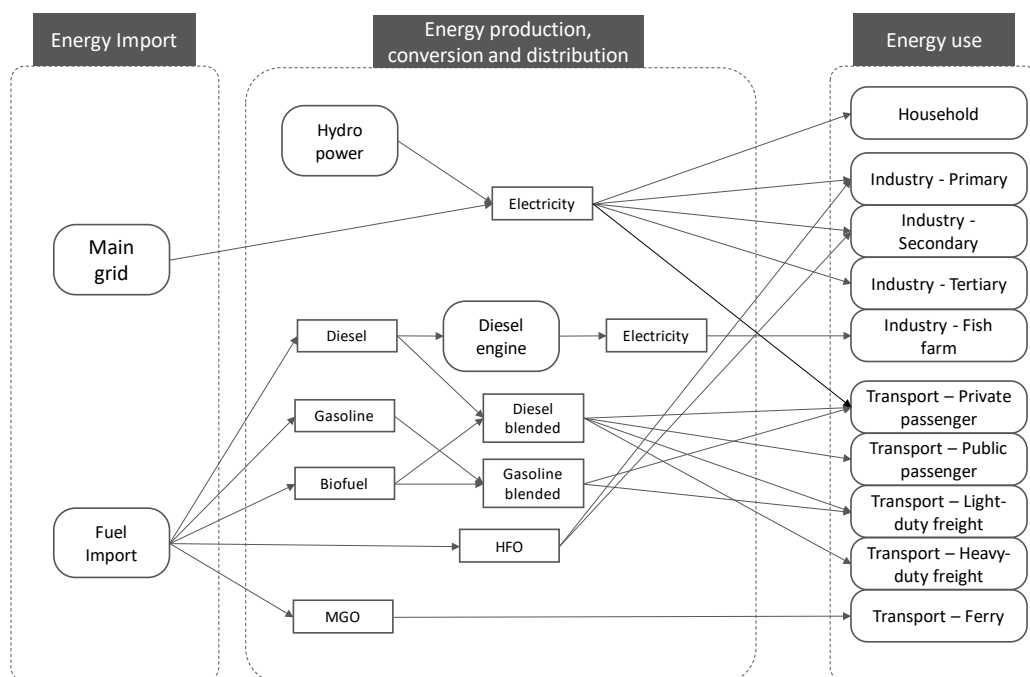

Figure 40 – Reference Energy System for TIMES-Hinnøya (Zhou W. and Assefa Hagos D. et al., 2020)



7.4. DATA SOURCES AND ASSUMPTIONS

7.4.1. Demand and electricity prices evolution

7.4.1.1. Demand growth drivers

Demand evolution is inserted as driver in the model. In fact, the future energy demand growth in residential sector is merely based on the population growth forecast of Statistics Norway (SSB) for the medium growth in fertility, life expectancy, internal migration, and immigration called MMMM scenario (SSB, 2018). As for the primary, secondary, and tertiary sectors it is based on GDP growth shown in Table 6. It should be noted that in the model, the evolution of Grytøya energy demand only represents the fish farms.

Table 6 - The total national GDP growth forecast (index 100=2013)

Year	2013	2014	2015	2020	2030	2040	2050	2060
GDP	100	102.22	103.85	111.28	131.99	150.48	175.46	205.79

The future transport service demand, or mobility demand, however, is based on the national transport model of Norway (NTM) in (Madslie et al., 2019). The future transport demands are presented in Table 7 by region.

Table 7 - Annual transport service demand growth by transport mode. It shows the annual growth for both short and long-distance trips (Madslie et al., 2019)

Demand	Harstad		Rest Hinnøya	
	Yearly growth rate		Yearly growth rate	
	2018-2030	2030-2050	2018-2030	2030-2050
Car (short)	0.56 %	0.47 %	0.44 %	0.57 %
Car (long)	0.21 %	0.74 %	1.20 %	0.9 %
Vans& small lorries (short)	2.01 %	1.6 %	1.95 %	1.91 %
Vans& small lorries (long)	2.01 %	1.6 %	1.95 %	1.91 %
Large Lorries (short)	2.01 %	1.6 %	1.95 %	1.91 %
Large Lorries (long)	2.01 %	1.6 %	1.95 %	1.91 %
Busses (short)	0.54 %	0.43 %	0.54 %	0.43 %
Busses (long)	0.30 %	0.41 %	0.30 %	0.41 %
Passenger vessel	2.05%	0.96%	2.05%	0.96%
Freight vessel	2.05%	0.96%	2.05%	0.96%

Based on the above table, transport drivers for the road transport are calculated according to the following equation:

$$\text{Transport driver}_t = \text{Base index} * (1 + \text{growth rate}_t)^{t-t_0}$$



Consequently, the resulting calculation can be represented below,

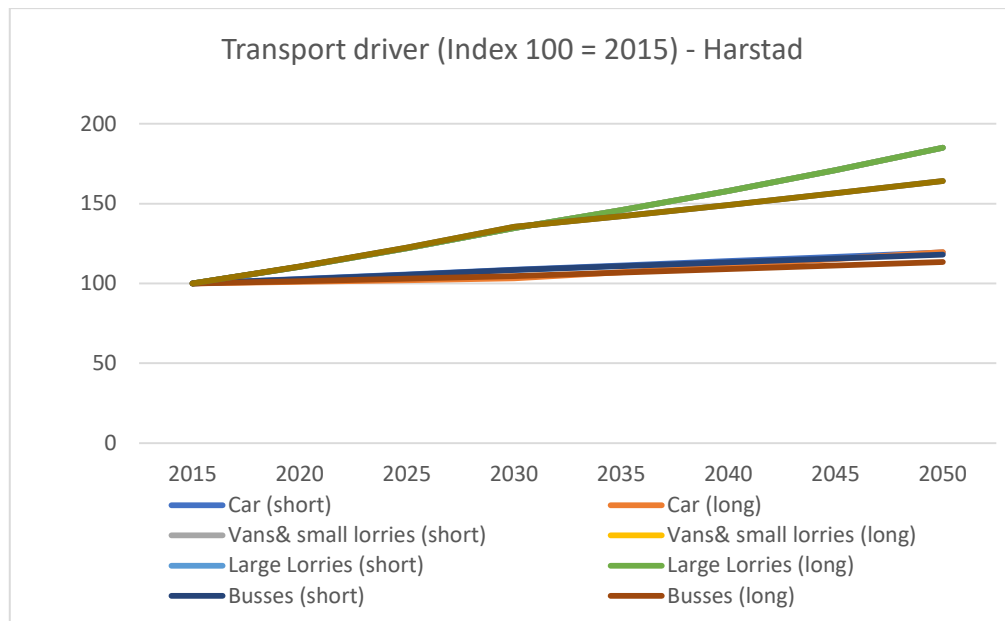

Figure 41 - Transport driver (Index 100 = 2015) - Harstad

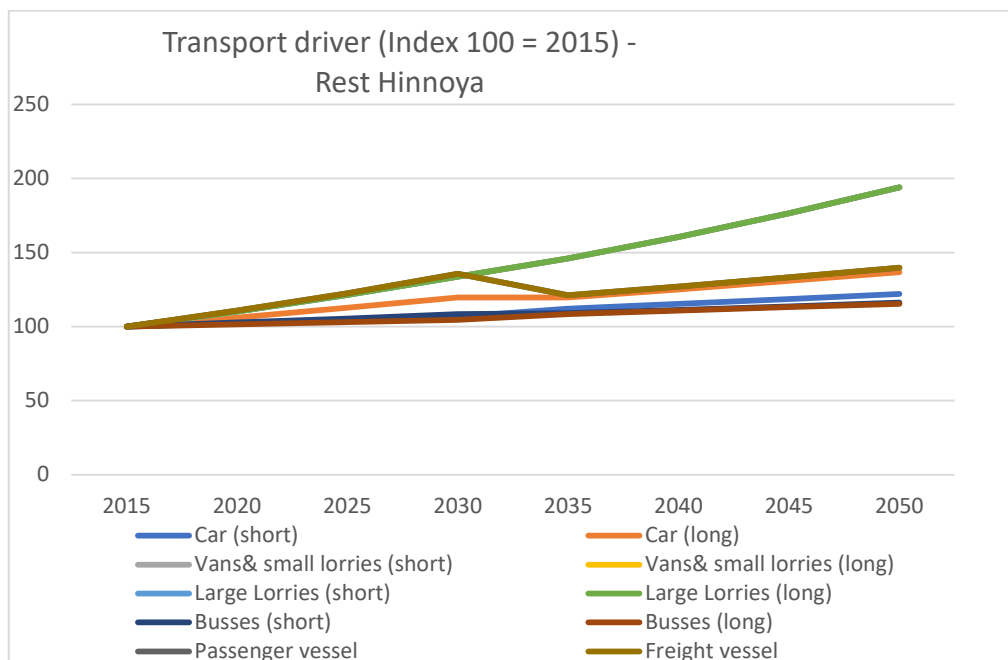

Figure 42 - Transport driver (Index 100 = 2015) - Rest Hinnøya

7.4.1.2. Electricity Prices forecast

Hinnøya is connected with NO4 market region with a total of 700 MW transmission capacity. The connection between Hinnøya and Grytøya is also 3-4MW. Since NO4 is connected with neighboring market region SE1 (Sweden), the island will export when the electricity market price in SE1 is higher than NO4 and vice versa, if any. The import-exports are calibrated based on the actual 2015 prices of the Nordpool database. The future electricity prices are based on NVE forecasts in between 2020 and 2040; 39 €/MWh, 36 €/MWh, and 42 €/MWh in 2022, 2030, and 2040, respectively (NVE, 2019a).

7.4.2. New technologies

Processes were added into the model to respond to the project's goals and targets as well as well to propose additional solutions that would be viable on the long-term.



Concerning the electricity supply, the Norwegian Water Resources and Energy Directorate (NVE) presented a GIS atlas where it was shown that there is a potential for new hydroelectricity power plants (Model documentation). As such, wind potential is explored in the model with two choices for implementation: on-shore and off-shore, the latter being a proposal for a decarbonisation of the electricity supply for the fish farmers. However, these technologies are not implemented on the territory in context of GIFT, but it would be interesting to explore their impact on the energy system in terms of decarbonization and flexibility.

Regarding the transport sector decarbonization, the project GIFT proposes the EMS and EV chargers to facilitate and ensure the transition to zero emission vehicles. This goes in line with the Norwegian government dedicated policies for the decarbonization of the transport sector. In addition, the EV smart chargers require as a pre-requisite a deployment of EVs to ensure their economic viability (Norwegian Electric Vehicle Association, 2021). These policies target the road transport and maritime transport. In a white paper from 2017 (Meld. St. 41 (2016–2017)), the Government set a working target of a cut of 35–40 % (plans to increase the cuts to 50% with a contingency on the technology maturity) in emissions from the transport sector by 2030 compared with 2005 in order to support efforts to reduce emissions in the transport sector.

For road transport, the White Paper on Transportation (NTP) (Meld. St. 33 (2016–2017)) (Norwegian Ministry and of Climate and Environment, 2016) sets new targets for the sales of zero emission vehicles. For instance, all new passenger cars and light vans should be zero emission in 2025. For maritime transport, domestic shipping and fishing account for around 8.6 per cent of Norwegian emissions. The government has an ambition to halve these emissions by 2030. In its action plan for green shipping³⁶, the government highlighted the maritime industry's opportunity to reduce emissions and increase value by developing and commercialising zero and low emission solutions (Norwegian Ministry of Petroleum and Energy and Norwegian Ministry of Climate and Environment, 2020). Furthermore, incentives like tax Exemption on registration of the new vehicles, traffic insurance and the re-registration, road usage (Norway's Fourth Biennial Report 2020, Framework Convention on Climate Change).

On another hand, there are several measures in place that are affecting greenhouse gas emissions from the transport sector. The tax policy is central, and the most important measure is the CO₂ tax, which is a cross-sectoral measure. The Norwegian government released in (*White paper Norway's Climate Action Plan (Meld. St. 13 (2020-2021))*) the gradual increase of taxation on ETS and non-ETS emissions. This will include the transport sector.

These policies are pivotal enablers for the deployment of EVs in Norway and for low emission ships, which are both included in the framework of GIFT. Accordingly, studying the impact of their deployment on the power system in a long-term perspective is thought to be relevant.

Storage technologies were also implemented in the model. In context of the project, the Elestor HBr flow battery is going to be installed in Harstad. Furthermore, for the fish farms, it is proposed to use Li-ion batteries which are used as decentralized storage technologies.

7.4.2.1. Potential renewable energy production

a) Hydropower plants

NVE has presented a GIS atlas showing the availability of feasible small-scale hydropower plants potential in whole Norway under 0.30 €/kWh and between 0.3 and 0.5 €/kWh (NVE, 2019). The corresponding potentials in Harstad, rest Hinnøya, and Grytøya were 2.41 MW, 16.34 MW, and 1.24 MW, respectively. The annual capacity factors were 55% in Harstad and 48% in Rest Hinnøya and Grytøya. These potentials are used to limit new investments in the model (NTNU, 2020).

b) Wind power plants

A study was conducted by team NTNU on the choice of power for wind turbine. It concluded, and by considering factors related to investment costs, types of wind turbines available in the market and finally, the turbine size is 50 kW for both onshore and offshore wind farms with various cost components with



declining rates throughout the horizon of the study. The capacity factor that was taken from the nearest wind farm to the island (with a total capacity of 32.5 MW) (NVE, 2019) and used for modelling potential wind turbine installation.

Technical parameters are found in section 10.2.1.1.

7.4.2.2. Low emission transport technologies

All the transportation fleet’s evolution is modelled in TIMES-Hinnøya. In the private passenger transport segment, a variety of low-carbon technologies are included: conventional diesel/gasoline engine vehicles with blended fuels of oil and biofuels, battery electric vehicles (BEV), plug-in hybrid electric vehicles (PHEV), hydrogen fuel cell Vehicles (HFCV). All the vehicles are characterized by size (small, medium and large), as well as driving range (short, medium and long). Key parameters including fuel economy, capital costs and O&M costs are included in the model covering all the vehicle sizes and transport distances. The freight transport is also included in the model, including buses and vans, light and heavy lorries with including electrification or the use of hydrogen as fuel. All parameters are available in section 10.2.1.

Battery electric vehicles (private cars) is on an increasing trend in Harstad (Deliverable D7.2 HLK, 2020), the deployment of EVs is seen all over Norway as the policies put in place by the Norwegian Ministry of Transport offer proper incentives and government taxation rules that foster this deployment (see section 7.4.2) In addition they are related to the solutions proposed in GIFT.

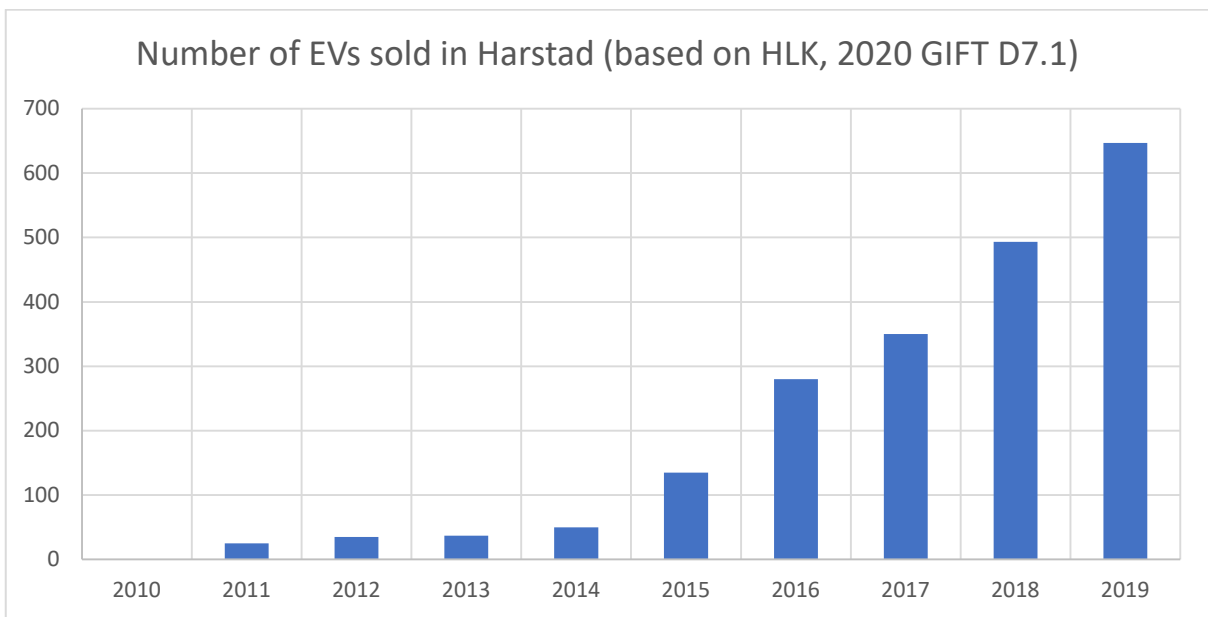

Figure 43- Number of EVs sold in Harstad (based on HLK, 2020 GIFT D7.1)

In this context, the Norwegian Electric Vehicle Association has looked at the experiences with charging infrastructure in Norway. The study also shows that electric car users prefer to charge the car at home, given the low price of electricity in Norway. It was noted also that most users use regular home sockets which constitutes a fire hazard. Hence, the municipality within the context of GIFT project projects that the need for home and public chargers is necessary for the future.

For the modelling of electric vehicles, it was chosen to model these as batteries so that the charging time can be manipulated and deferred to the off-peak hours in the TIMES-Hinnøya (as a standard timeslice storage process operating at daynite level). Furthermore, it exists three types of Battery Electric Vehicles (BEVs) with capacities of 15 kWh, 30 kWh and 60 kWh. This is due to the fact that the transportation sector for private passengers is divided by 3 segments, long trips are for distances longer than 70 km. Short distance trips are divided by extra short and medium trips with a 50% share each with a total share accounting for 73%.



The technical parameters for years 2020, 2030 and 2050 that are relevant to the Battery Electric Vehicles that can be deployed in Hinnøya island cluster, are summarized in the table below:

Table 8 - Technical parameters for years 2020, 2030 and 2050 of the Battery Electric Vehicles

Parameter	Value
Battery storage capacity per vehicle by size	Small: 15 kWh Medium: 30 kWh Large: 60 kWh
Lifetime	2020: 6 years 2030: 6 years 2050: 6 years
Specific investment costs	<i>Small:</i> 2020: 249 €/kWh 2030: 180 €/kWh 2050: 121 €/kWh <i>Medium:</i> 2020: 200 €/kWh 2030: 145 €/kWh 2050: 97 €/kWh <i>Large:</i> 2020: 155 €/kWh 2030: 113 €/kWh 2050: 75 €/kWh
Round trip efficiency	95%

Further to that, the charging stations are also included in the model with their technical parameters related to cost of investment.

Table 9 - Charging stations technical parameters found in (NTNU, 2020)

Parameter	Value
Capacity	Home Charging: 7.2 kW Public Charging: 22 kW
Lifetime	20 years
Investment cost	1752 €/kWh
O&M costs	350 €/kWh



7.4.2.3. Stationary battery and flow storage

There are two types of storage technologies implemented in the model but each one is used for different purposes. In fact, energy storage can play many roles in electricity systems including arbitrage, capacity contributions, and ancillary services provision as mentioned in section 3.5.1. In this sense, the different possibilities of using storage in addition to the changing market and regulatory aspects makes the modelling of storage challenging in the long-term energy planning. Furthermore, storage technologies are sensitive to temporal and spatial resolutions and their value is dependent on capturing other system generation resources for charging (Bistline et al., 2020).

In context of GIFT, the flow battery from Elestor is used in Harstad where it will be installed with the EMS and will be considered as part of the grid providing support. And so, it will be storing the electricity from the grid during off-peak hours and discharging needed.

The Elestor flow battery is a HBr (hydrogen bromide) system designed to store the energy produced by renewable energy systems. It has a capacity of 250 kWh and it is composed by two bidirectional inverters that can achieve a total nominal power rating of 50 kW.

Details provided by Elestor regarding the material, power and energy are gathered in the table below.

Table 10 – Technical parameters of ELESTOR flow battery

		ELESTOR flow battery																																																																																																																																																																																																																																																																						
Materials		HBr (hydrogen bromide, as electrolyte)																																																																																																																																																																																																																																																																						
Power capacity (kW)		50																																																																																																																																																																																																																																																																						
Energy capacity (kWh)		250 (Negligible loss of energy capacity during lifetime)																																																																																																																																																																																																																																																																						
Efficiency (%)		charging or discharging efficiency of around 80% (to be confirmed with practical tests 2020Q4); 64% for the roundtrip efficiency																																																																																																																																																																																																																																																																						
		<p><i>NB efficiency depends on the operational mode of the system, that is variable. Please see below example how such efficiency picture will look like. It will be a table with efficiencies depending on SoC and power.</i></p> <table border="1"> <thead> <tr> <th colspan="2"></th> <th colspan="10">Electrolyte SoC [%]</th> </tr> <tr> <th colspan="2"></th> <th>0 - 10</th> <th>11 - 20</th> <th>21 - 30</th> <th>31 - 40</th> <th>41 - 50</th> <th>51 - 60</th> <th>61 - 70</th> <th>71 - 80</th> <th>81 - 90</th> <th>91 - 100</th> </tr> </thead> <tbody> <tr> <td rowspan="2">10</td> <td>Charge</td> <td></td><td></td><td></td><td></td><td></td><td></td><td></td><td></td><td></td><td></td> </tr> <tr> <td>Discharge</td> <td></td><td></td><td></td><td></td><td></td><td></td><td></td><td></td><td></td><td></td> </tr> <tr> <td rowspan="2">20</td> <td>Charge</td> <td></td><td></td><td></td><td></td><td></td><td></td><td></td><td></td><td></td><td></td> </tr> <tr> <td>Discharge</td> <td></td><td></td><td></td><td></td><td></td><td></td><td></td><td></td><td></td><td></td> </tr> <tr> <td rowspan="2">30</td> <td>Charge</td> <td></td><td></td><td></td><td></td><td></td><td></td><td>95</td><td>97</td><td>98</td><td>99</td> </tr> <tr> <td>Discharge</td> <td></td><td></td><td></td><td></td><td></td><td></td><td></td><td></td><td></td><td></td> </tr> <tr> <td rowspan="2">40</td> <td>Charge</td> <td></td><td></td><td></td><td></td><td>88</td><td>90</td><td></td><td></td><td></td><td></td> </tr> <tr> <td>Discharge</td> <td></td><td></td><td></td><td></td><td></td><td></td><td></td><td></td><td></td><td></td> </tr> <tr> <td rowspan="2">50</td> <td>Charge</td> <td></td><td></td><td></td><td></td><td></td><td></td><td></td><td></td><td></td><td></td> </tr> <tr> <td>Discharge</td> <td></td><td></td><td></td><td></td><td></td><td></td><td></td><td></td><td></td><td></td> </tr> <tr> <td rowspan="2">60</td> <td>Charge</td> <td></td><td></td><td>77</td><td>79</td><td></td><td></td><td></td><td></td><td></td><td></td> </tr> <tr> <td>Discharge</td> <td></td><td></td><td></td><td></td><td></td><td></td><td></td><td></td><td></td><td></td> </tr> <tr> <td rowspan="2">70</td> <td>Charge</td> <td></td><td></td><td></td><td></td><td></td><td></td><td></td><td></td><td></td><td></td> </tr> <tr> <td>Discharge</td> <td></td><td></td><td>74</td><td>75</td><td>76</td><td></td><td></td><td></td><td></td><td></td> </tr> <tr> <td rowspan="2">80</td> <td>Charge</td> <td></td><td></td><td></td><td></td><td></td><td></td><td></td><td></td><td></td><td></td> </tr> <tr> <td>Discharge</td> <td></td><td></td><td></td><td></td><td></td><td></td><td></td><td></td><td></td><td></td> </tr> <tr> <td rowspan="2">90</td> <td>Charge</td> <td></td><td></td><td></td><td></td><td></td><td></td><td></td><td></td><td></td><td></td> </tr> <tr> <td>Discharge</td> <td>61</td><td>63</td><td>66</td><td>67</td><td>68</td><td>70</td><td>75</td><td>78</td><td>89</td><td>98</td> </tr> <tr> <td rowspan="2">100</td> <td>Charge</td> <td></td><td></td><td></td><td></td><td></td><td></td><td></td><td></td><td>NA</td><td>NA</td> </tr> <tr> <td>Discharge</td> <td></td><td></td><td></td><td></td><td></td><td></td><td></td><td></td><td>97</td><td>99</td> </tr> </tbody> </table>												Electrolyte SoC [%]												0 - 10	11 - 20	21 - 30	31 - 40	41 - 50	51 - 60	61 - 70	71 - 80	81 - 90	91 - 100	10	Charge											Discharge											20	Charge											Discharge											30	Charge							95	97	98	99	Discharge											40	Charge					88	90					Discharge											50	Charge											Discharge											60	Charge			77	79							Discharge											70	Charge											Discharge			74	75	76						80	Charge											Discharge											90	Charge											Discharge	61	63	66	67	68	70	75	78	89	98	100	Charge									NA	NA	Discharge									97
		Electrolyte SoC [%]																																																																																																																																																																																																																																																																						
		0 - 10	11 - 20	21 - 30	31 - 40	41 - 50	51 - 60	61 - 70	71 - 80	81 - 90	91 - 100																																																																																																																																																																																																																																																													
10	Charge																																																																																																																																																																																																																																																																							
	Discharge																																																																																																																																																																																																																																																																							
20	Charge																																																																																																																																																																																																																																																																							
	Discharge																																																																																																																																																																																																																																																																							
30	Charge							95	97	98	99																																																																																																																																																																																																																																																													
	Discharge																																																																																																																																																																																																																																																																							
40	Charge					88	90																																																																																																																																																																																																																																																																	
	Discharge																																																																																																																																																																																																																																																																							
50	Charge																																																																																																																																																																																																																																																																							
	Discharge																																																																																																																																																																																																																																																																							
60	Charge			77	79																																																																																																																																																																																																																																																																			
	Discharge																																																																																																																																																																																																																																																																							
70	Charge																																																																																																																																																																																																																																																																							
	Discharge			74	75	76																																																																																																																																																																																																																																																																		
80	Charge																																																																																																																																																																																																																																																																							
	Discharge																																																																																																																																																																																																																																																																							
90	Charge																																																																																																																																																																																																																																																																							
	Discharge	61	63	66	67	68	70	75	78	89	98																																																																																																																																																																																																																																																													
100	Charge									NA	NA																																																																																																																																																																																																																																																													
	Discharge									97	99																																																																																																																																																																																																																																																													
		<p><i>This list will be finetuned over time and will be included inside the battery model</i></p>																																																																																																																																																																																																																																																																						



Ramp constraints (p.u. per min)	<i>In principle direct ramp-up/ramp-down to full charge power shall be possible. Further experiments needed to confirm this. Further measurements to be done on pilot models, more info expected by end 2020</i>
Time of charge/discharge (s)	Fast switching operation possible to change over (milliseconds).
Lifetime (years)	<i>T.b.d. (Target 20 years)</i>
Max cycles	15,000 charge/discharge cycles (expected)
Losses	Some losses will occur (e.g. hydrogen leakage, parasitic power) <i>To be quantified during project</i>
Energy cost (€/kWh)	Target 50 €/MWh (LCOS)
Total project cost	2025: 300 €/kWh + 3000 €/kW 2035 : 80€/kWh + 800 €/kW

As for the Li-Ion battery, it is a solution evaluated for the fish farms in Grytøya to study its impact on reducing their dependency on the diesel generators, but also to have a reliable source of electricity without causing a competition vis-à-vis the residents of this small island. These batteries can be installed on the island and/or be used by the farmers and installed on their barges; in that case an additional installation cost in the existing barge needs to be added. The whole system costs of Li-Ion batteries are shown in section 10.2.1.3.

7.4.2.4. Electric ferry (E-Ferry)

Norway has been recently investing more and more in finding sustainable solutions for the speed boat and ferry transportation sector (Hafenstrom, 2020). Indeed, the first full electrical passenger-car ferry was launched in Norway on October 2019. Grytøya receives electricity through two radial submarine cables of 2.9 km long and only carry 22 kV. Since the submarine cable presents vulnerability and that Grytøya is faced voltage issues, the only charger will be set up at Stornes port in Hinnøya from the Harstad side. To deal with the spikes on the grid caused by the electric ferry recharging, the DSO will invest in a battery buffer of 1 MW to allow for the ferry to recharge whenever it arrives portside without having to connect to the grid.

According to (Hafenstrom, 2020) it is estimated that the electric ferry will spend between 130 and 140 kWh traversing between the ports of Stornes at Hinnøya and Bjørnerå at Grytøya depending on the level of electrification of the ship. Consequently, an e-ferry can be either fully, 50% or 75% electric where the remaining power is provided by marine gasoil (MGO). The fuel economy of the ferry in MGO and full electric mode are assumed to be 2.8 km/GJ and 6.3 km/GJ, respectively.

There are three types of e-ferries that are included in the model as demand technologies through technical parameters, investment and O&M costs and lifetime and are summarized in the table below. It should be noted that fossil fuel-based ferries such as the direct injection and compression ignition (DICI), port injection spark ignition (PISI), port injection dual-fuel (PIDF), and high-pressure direct injection (HPDI) gas (NTNU, 2020) were considered in the model keeping in mind that the transport GHG emissions are subject to taxation and explained in section 7.4.3.

Table 11- Parameters and assumptions related to the ferry transport (NTNU, 2020)

Technology	Fuel	Fuel economy	Capital cost	O&M cost	Lifetime
------------	------	--------------	--------------	----------	----------



		(kvehicle- km/TJ)	(MEUR/vehicle)	(MEUR/vehicle/yr)	(years)
DICI engine	MGO	2.81	6.5	0.227	35
PISI engine	LNG	2.18	7.15	0.250	35
PIDF engine	LNG	2.81	6.82	0.239	35
	MGO				
HPDI engine	LNG	2.81	7.47	0.262	35
	MGO				
Electric engine (100%)	Electricity	6.3	10.82	0.379	35
Electric engine (50%)	Electricity MGO	6.3 2.81	10.03	0.351	35
Electric engine (75%)	Electricity MGO	6.3 2.81	10.43	0.365	35

N.B These parameters are assumed to be constant over the period of the horizon.

7.4.3. Scenarios

The main scenarios were developed in order to consider different possible evolution of the energy system while integrating GIFT project's objectives. The base model interprets the current state of the energy system as well as the policies enforced by the national authorities, constraints related to the taxation of the use of oil products in the transport sector and GHG emissions (CO₂ and NO_x) from diesel and gasoline were implemented and used throughout the study. This taxation is represented by an additional cost for the processes using these oil products and were modelled as follows:

$$TAX = C_{emission_i} \times \sum Emission_c$$

Where $C_{emission_{CO_2}} = 50 \text{ euros}/tCO_2$ and $C_{emission_{NO_x}} = 2280 \text{ euros}/tNO_x$

And c is the emitting commodity which emission is defined in the model in terms of kt/TJ. The taxation is set on the net amount of the commodity used in all three regions of the model and for every year of the horizon.

Table 12- Emission values in kt/TJ based on IPCC 2006 (Guidelines for National Greenhouse Gas)

Commodity c	Diesel	Gasoline	LPG	Nat. Gas	Heavy Fuel Oil	LNG	MGO
Units	kt/TJ	kt/TJ	kt/TJ	kt/TJ	kt/TJ	kt/TJ	kt/TJ
CO₂	0.074	0.069	0.063	0.056	0.077	0.056	0.074
NO_x							0.00025

As for the fuel tax, it is applied on the process using the fuel commodities in the transport sector. As for the diesel used for the generators to provide electricity for the fish farms, the current policies in Norway still are excluding this sector from the tax scheme.

FLEX scenario: The purpose of this scenario is to implement the proposed solutions of flexibility of the prosumers found in GIFT by introducing the EV charging, E-ferry, VPS and Factory EMS. In this scenario, EV charging is implemented with modelling the EVs as battery storage devices and the charging stations as processes as explained in subsection 7.4.2.2. We interpret the flexibility depending on the off-peak charging that could be offered by EV owners if they all participate in the flexibility operation which is the "smart charging". The fact that the EVs are represented as storage devices (with technical parameters



inserted in the model) ensures their charging in a way to meet the service demand for transport and the demand pattern which are exogenous input. As the decarbonisation of the transport sector is one main concern of the Norwegian government as detailed in section 7.4.2, we study the evolution of BEV deployment which is also enhanced by the decrease in costs of the batteries used in the vehicles. Since TIMES chooses a least cost solution and to avoid an increased investment in small cars, a constraint on the investment in the types of vehicles was implemented in order to distribute the vehicles between small, medium and large ones. Accordingly, EV chargers were added as processes connected to these batteries.

As for the e-ferry, two types were implemented fully electric and hybrid e-ferry (electric with MGO) connecting it to a charger, investments in ships that do not use electricity as commodity were set to zero by a constraint on new investments after 2023, the assumed year when the e-ferry is operational for service just after the end of the project. This scenario represents the demand-side management impact with the additional decarbonization of the shipping sector.

ELSTR scenario:

The Elestor HBr Battery is modelled as a standard storage, and since it is placed in Harstad in context of GIFT, it will only be used in the Harstad region of the model and its capacity is fixed for the horizon of the model as given in the project.

HyWin scenario: Utilisation of local renewable energy

It is proposed here to exploit the natural resources available in the island. This is represented by including wind turbines and ROR hydro power which parameters were presented in section 7.4.2.1. Wind power is coupled to the Li-ion battery for Grytøya region which represents the fish farms in the TIMES-Hinnøya.

The three defined scenarios are mixed for studying the different possible evolutions of the energy system with the implementation of the flexibility solutions.

7.5. RESULTS

7.5.1. Final energy mix

The energy mix of the island cluster is analyzed according to the four scenarios that we chose. We notice that the integration of renewable energy in the case of the first two scenarios depends on the increase of imports. In FLEX and FLEX+ELSTR the imports at the end of the horizon constitute 81% of the total energy mix. With the introduction of local renewable sources, the imports share from the energy supply decreases and reaches 73% and 74% for HyWin+FLEX and HyWin+FLEX+ELSTR, respectively. This is a clear indication that the storage technologies can be utilized for different purposes, which necessitates to look at the results at a global as well as detailed level. Further elaboration on the storage are found in section 7.5.3.1. All four scenarios reduce drastically the share of diesel in the final energy mix. With FLEX+ELSTR the diesel accounts for 0.3% keeping in mind that it is a blended fuel with biodiesel. With the coupling of wind and storage we see that this share reaches nearly zero.

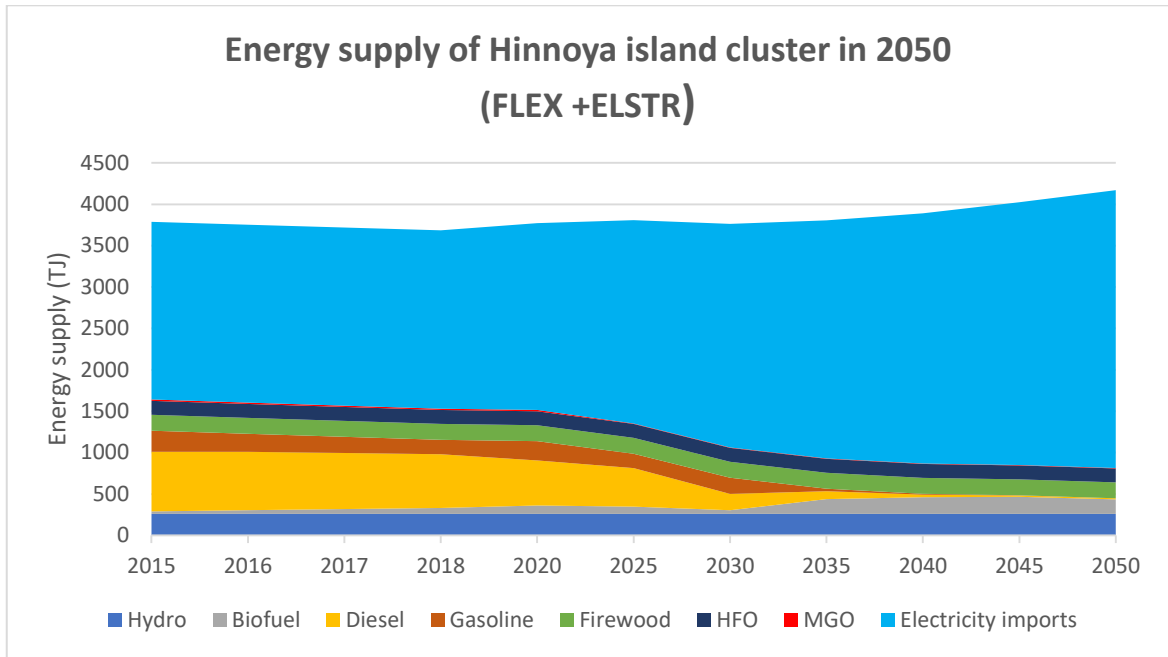

Figure 44 - Energy supply of Hinnoya island cluster in 2050 (FLEX + ELSTR)

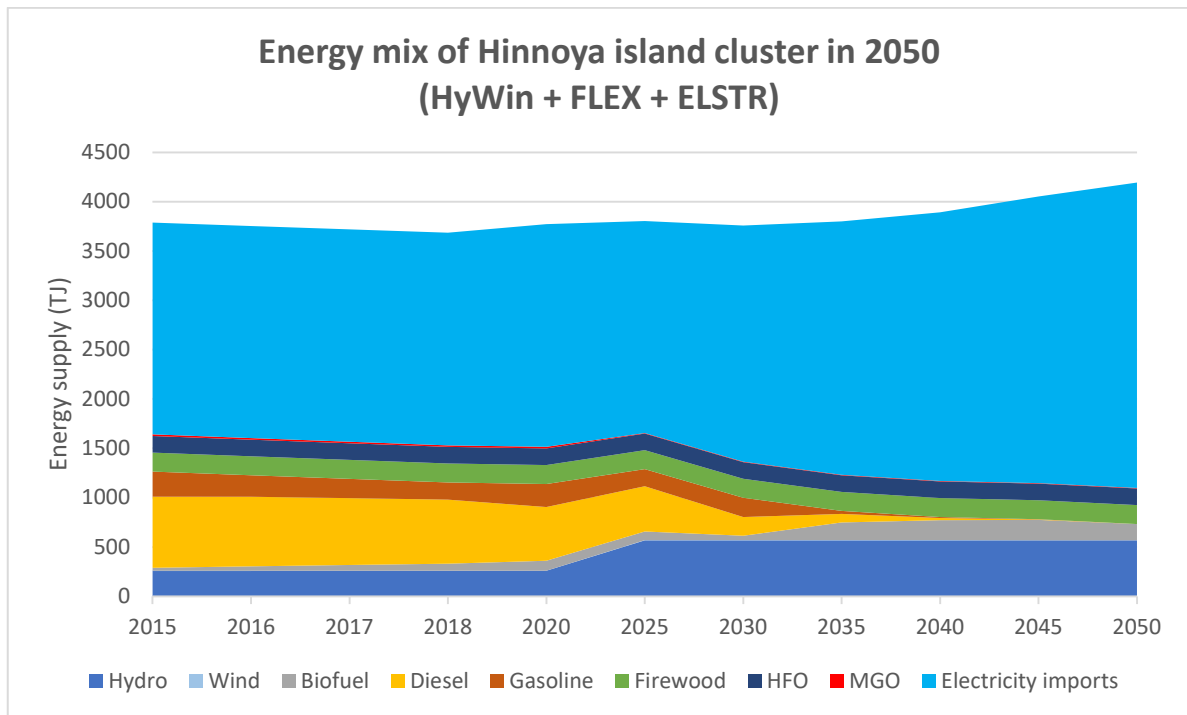

Figure 45 - Energy mix of Hinnoya island cluster in 2050 (HyWin + FLEX + ELSTR)

When comparing the results obtained with the HyWin scenario with or without storage technologies, the investment in the hydro and wind power plant starts earlier, in year 2025, in the first case whereas for the latter it is until year 2030 that the investment is made. This denotes that local energy production from variable renewable resources facilitates their integration in the energy mix.

7.5.2. System cost



The total discounted system cost (in millions €) of the four scenarios is shown in Figure 46.

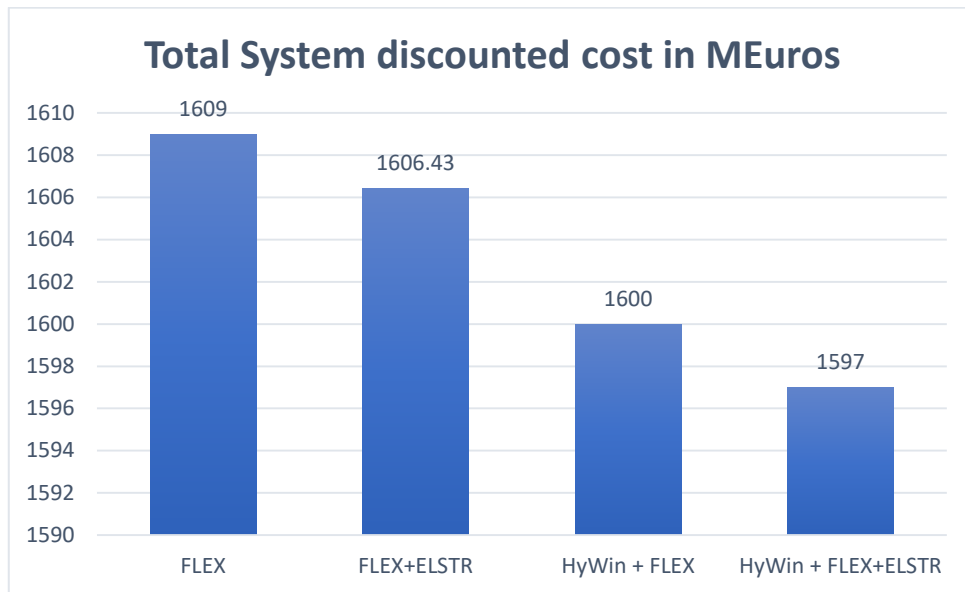

Figure 46 – Total discounted costs under different scenarios

In the FLEX+ELSTR, we find here the mix of the technical solutions and techniques of flexibility provided by GIFT project. We notice the decrease in costs with the introduction of storage in the system as it has the ability to store electricity from the imports from the main grid during off-peak hours which are at low prices. Exploiting renewable energy resources has however a greater impact in terms of cost decrease with 0.56% reduction in total system cost compared to a scenario only implementing flexibility strategies (scenario FLEX). This is translated by a reduction of imports (see section 7.5.1) and hence an increased independency of the island when investing in local renewable energy.

7.5.3. Flexibility of the prosumers

7.5.3.1. Chargers' control – "Smart charging"

- **Electric Vehicles Charging**

Based on (Knezović, 2016), there exist three types of charging strategies for electric vehicles. The uncontrolled charging consists of charging the vehicle at maximum power as soon as it connects to the grid. For passive control, only encouragements are given to owners to charge during low tariffs of electricity. For active control or smart charging, the charging is mostly made during low tariffs or off-peak periods in addition to a modulation of the charging power. Two possibilities for smart charging exist: unidirectional or bidirectional which consists of injecting power back to the grid. Below is a schematic summarizing the EV charging strategies.

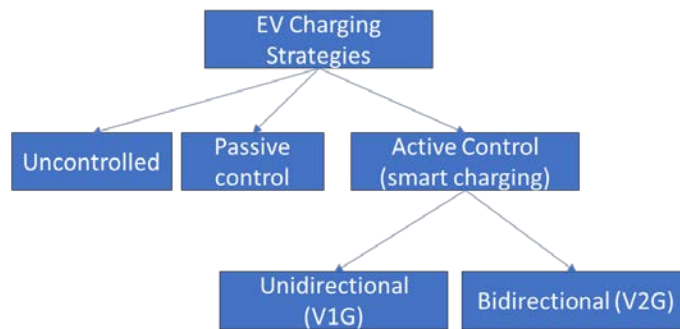

Figure 47 – Schematic summarizing the EV charging strategies adapted from (Knezović, 2016)

In Hinnøya island cluster the EVs will act in unidirectional mode and therefore provide flexibility to the grid through the VPS system which will assess the potential of the offered flexibility and shift from peak hours to off-peak hours to release the stress on the distribution grid. (Deliverable D7.1)

The results are shown for a typical winter working day under the FLEX scenario, showcasing the proposed charging curve of TIMES. To be coherent with GIFT solutions where EV chargers are deployed for private and public usage and to see the impact of the whole BEVs fleet, we aggregate the charging that can be done from private chargers (residential) or public (during working hours). The charging control strategy provided by TIMES consists of choosing the low electricity tariffs to charge the vehicles while meeting the demand for mobility represented by the discharge curve.

Prosumers are expected to charge their BEVs during the night period. Since the working hours on the land begin at 7:30 am (Deliverable D7.2), the owners of BEVs will tend to plug their vehicles when arriving to work. However, with the project’s initiative, awareness is made to offer flexibility during the first hour of work which is the beginning of the increase of the prices of electricity and the increase of demand (as seen in the below graph). This coincides with the results obtained where we see a gradual decrease in the charging curve starting 7:00 am.

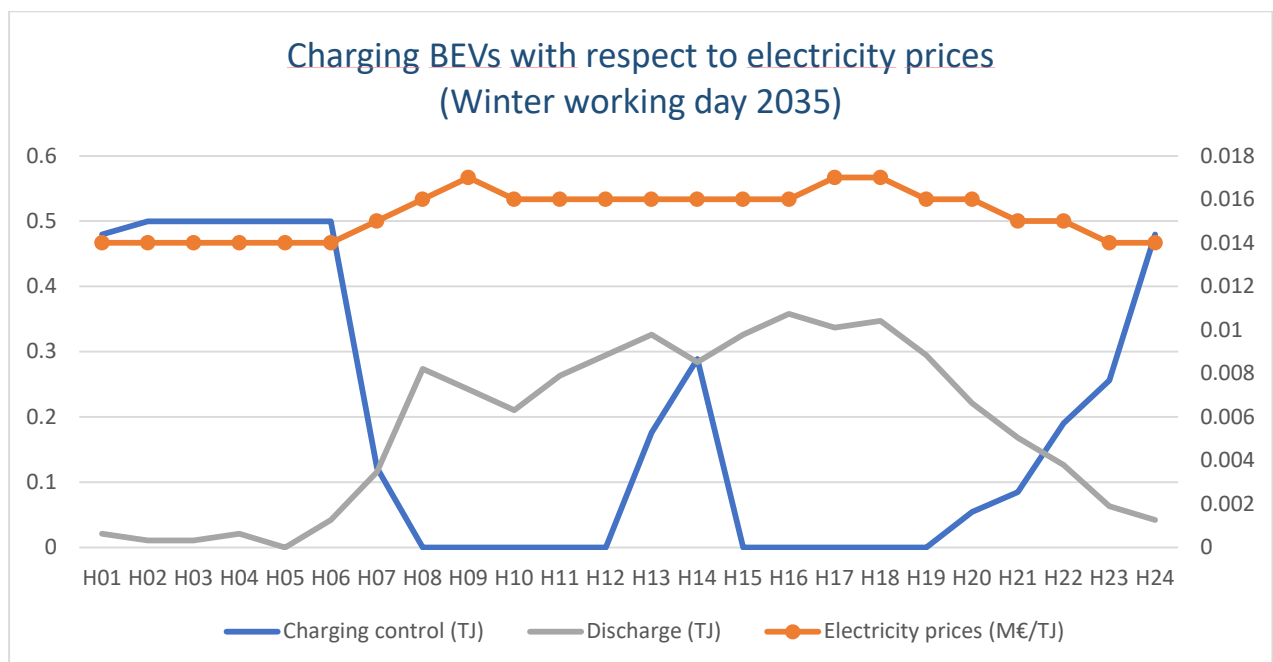

Figure 48 - Charging BEVs with respect to electricity prices (Winter working day 2035)

During hours 13 and 14 pm, we notice that a charging is being made. Looking closely at the results, we found that this charging is from the vehicles with 30 kWh capacity. These vehicles are used for the medium trips meeting the needs of the commuters in Hinnøya island cluster since the average distance per day is 30 km and this segment of vehicles can meet this demand.

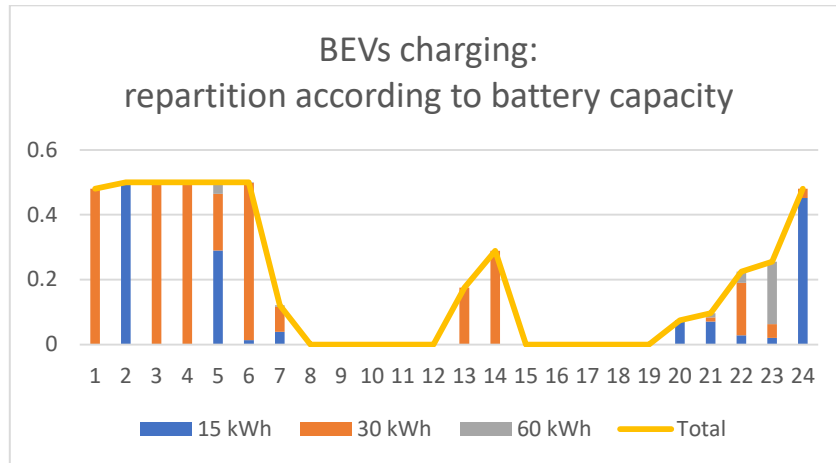

Figure 49 - BEVs charging: repartition according to battery capacity

According to (Turton and Moura, 2008) private vehicles are parked on average 93–96% of their lifetime, during which time each represents an idle asset. This means that the hours of utilisation over a year will be between 350 and 701 hours, non-utilisation hours will be around 8059 and 8409 hours. In case of home charging, 8 hours per day will be possible assuming that the vehicle is stationed near the residence of the consumers, this means for 2920 hours per year. In that sense, investments in home chargers would be required to enable the smart charging strategy effectively.

Looking at the impact of smart EV charging on the load curve, we find that the charging is able to smooth the load curve by the phenomena of valley filling during the night and the early morning hours from midnight till 7 AM. No additional demand is created during peak hours.

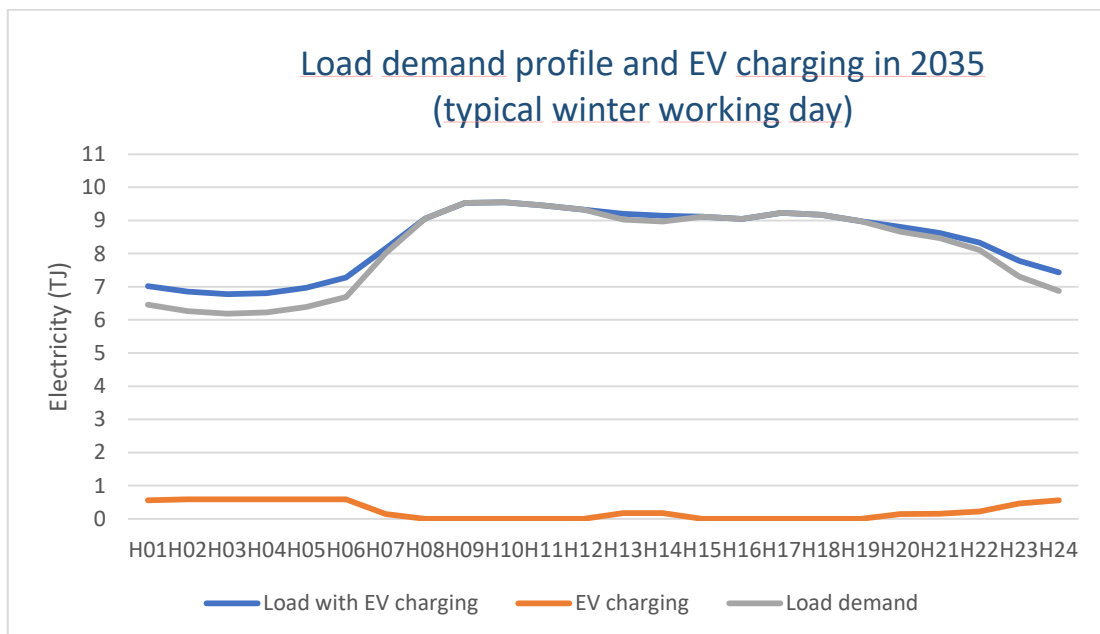

Figure 50 - Load demand profile and EV charging in 2035 (typical winter working day)

However, we note that the charging pattern presents dependency on price signals. In fact, during summer working days where the prices of electricity are lower than winter owing to the hydro dominated electricity in Norway, charging was done during the afternoon coinciding with peaks. Hence, the demand-side management needs a proper strategy to avoid additional demand during this time with power control.

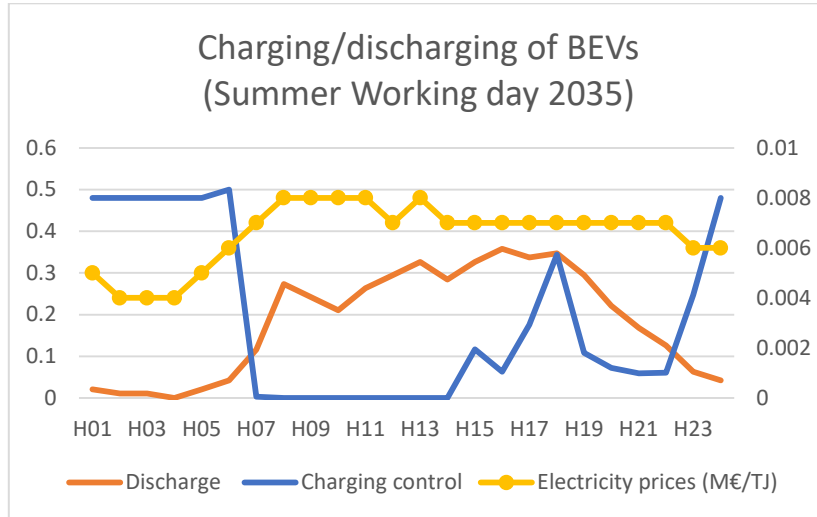

Figure 51 - Charging/discharging of BEVs (Summer Working day 2035)

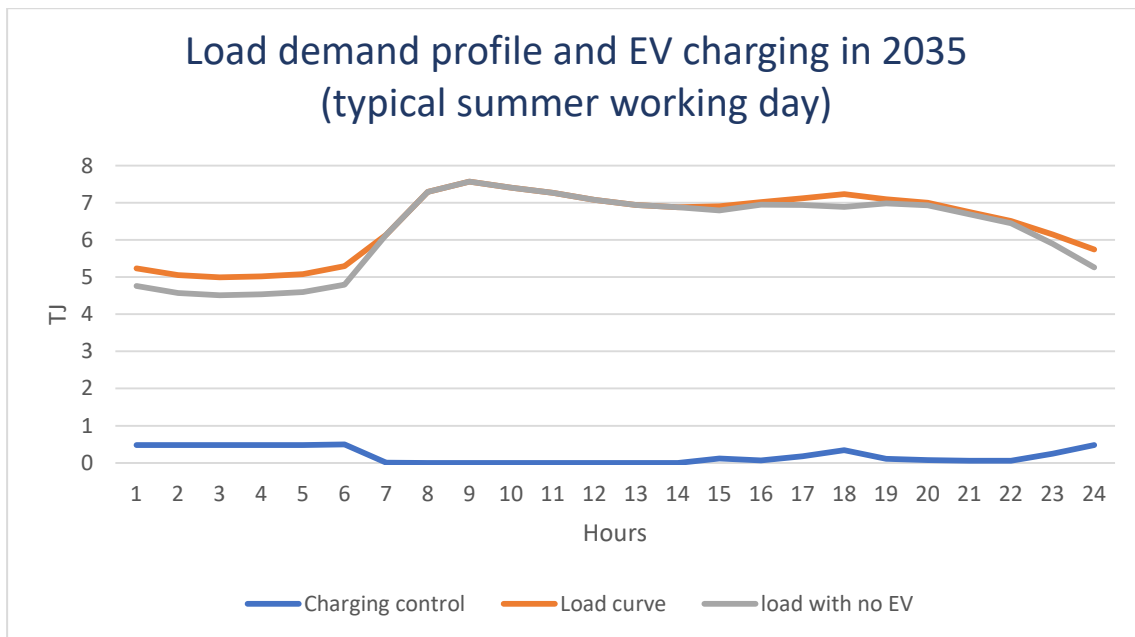

Figure 52- Load demand profile and EV charging in 2035 (typical summer working day)

- **E-Ferry Charging**

We notice that the MGO is still existing in the final year of the horizon, but this is based on the assumption that one investment is made for the e-ferry in 2023. In fact, the results show that the hybrid ferry at 50% electricity is chosen by the model and therefore explain the persistent MGO in the energy mix of the transport sector. When forcing the investment of the e-ferry with full electrification into the model, the MGO disappears from the final energy mix starting year of the investment.

We also analyse the charging pattern in order to assess the time the ferry would be connected to the charger. During these hours, the ferry through the connected EMS would be controlled in order to reduce or increase its charging and thus offering flexibility.

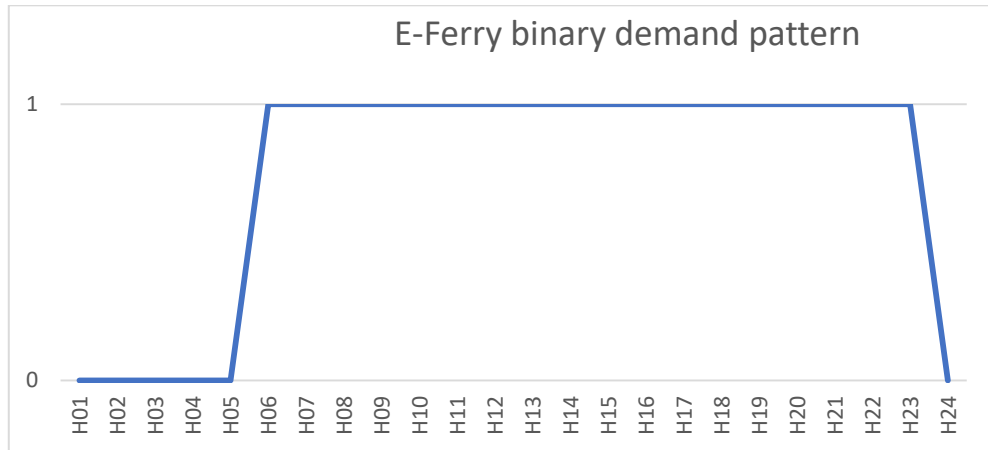

Figure 53 – E-Ferry binary charging

7.5.3.1. Flow battery results

In the FLEX+ELSTR scenario, we implement the Elestor HBr battery in the region of Harstad with a power capacity of 50 kW through setting a constraint on its capacity while its investment is enforced in year 2025 since cost-related data are available from this year.

Accordingly, we look at the results of charging and discharging of the process on the seasonal and daynite level of the model. We notice that the battery is functional from a least-cost perspective from June (month 06) till December (month 12), charging during the second and fourth hour of the day and discharging from 8 till 12 and at 1 pm so in total of 5 hours ($50\text{kW} * 5 \text{ hours} = 250 \text{ kWh}$) following the peak hours where the grid needs support. The charging/discharging pattern on the daynite level follows the low prices of the imported electricity. In the context of the project, it should provide grid support and this can be seen on finer timescales than the hour scale of the TIMES-Hinnøya.

In another part, we let the model choose the capacity of the battery for the 3 regions represented in the model. However, this assumption is dependent on the evolving design of the battery which is in real life a constraint on its location due to its size which is currently 100 m^2 . The graph Figure 55 shows a concentration of investments in Grytøya. However, this does not imply that the small island needs this amount of storage to meet its demand. The fact that the results are based on economic optimization and that Grytøya only represents the fish farms in the evolution of the system should be considered in the analysis. Nevertheless, some conclusions can be made regarding the electricity trade. In fact, Harstad and Grytøya trade electricity through the submarine cables connecting these territories. With the implementation of storage, we notice larger shares of imports from NO4 to Harstad are made possible during months 6 to 12, since they are in consequence stored in Grytøya for later trade back during peak hours. We note that in the case of deployment of storage on the small island cluster, the DSO would benefit from the EMS, VPS and grid observability if connected to monitor and manage this trade avoiding congestion issues.

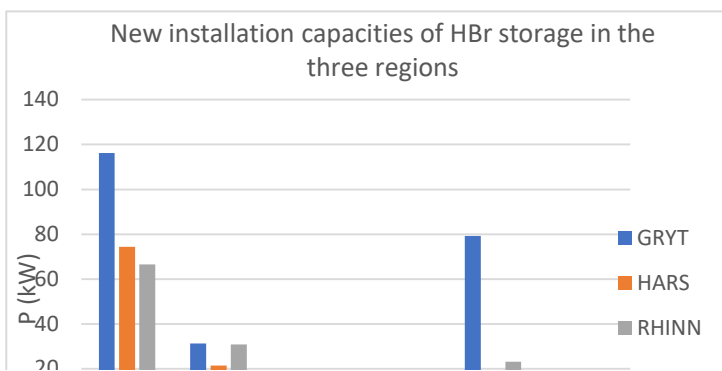

Figure 55- Assumed New installation capacities of HBr storage in the three regions

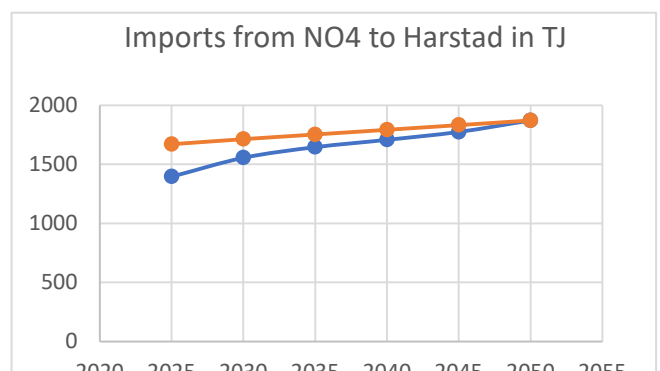

Figure 54 - Imports from NO4 to Harstad in TJ



7.5.4. Fish farms alternative power solutions

It is proposed to use local renewable energy resources for the decarbonization of the fish farms which consequently implies the use of alternative power solutions. This includes the investments in wind technologies coupled with Li-ion battery in order to limit the impact of the uncertainty and variability of wind. Moreover, this storage can be used also during the night during off-peak hours to charge from the electricity grid and discharging during peak hours thus replacing the need of consuming from the grid during these hours. Investment in the onshore wind (turbine of 50 kW capacity) with a total of capacity installed of 700kW for the whole horizon with 500kW in 2025. Nevertheless, investments in wind farms are multi-faceted as they are usually subject to questions related to environmental concerns and social acceptability and thus play an important role on the decision-making done by the local authorities.

We notice that even with the investments in wind energy and the battery, diesel (ELCDSL) is still used but a low value in 2045 and 2050 which implies that diesel generators would be needed. Since the diesel generators have minimum running time and level of delivered energy requirements per year, they would always need to be supplied by diesel.

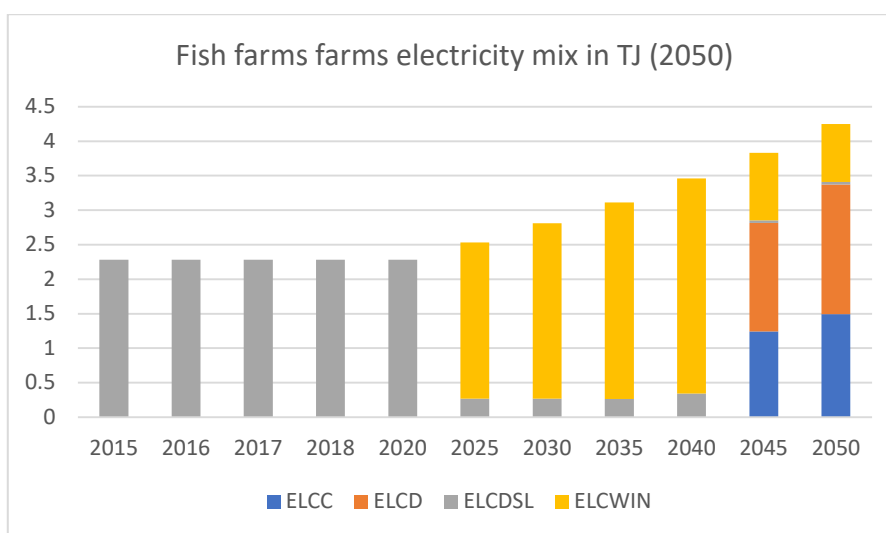

Figure 56 - Fish farms electricity mix (2050)

7.6. DISCUSSION

The TIMES-Hinnøya model configuration and the scenarios that replicate the solutions related to flexibility allow to draw several conclusions for the Norwegian demonstration site. First of all, the results obtained considering the proposed flexibility solutions of GIFT project promote the use of renewable energy through sector coupling with the transport sector, the main source of emission in the island. These solutions could lead to important improvements both in terms of costs and integration of renewable energy in the system while avoiding additional electricity demands during peak time. When local variable renewables deployment is supported and is coupled with the storage technologies, the system becomes more cost-effective and reduces its dependency to imports by 7% compared to a scenario with flexibility solutions. The analysis also allowed us to evaluate the use of these technologies used for different purposes: grid support and distributed solution.

The integration of renewable energy in the island's energy mix is done through the electrification of the transport sector which is majorly impacted by the policies of the national authorities of Norway in terms of incentives and applied taxation schemes. Also, it is enhanced by the projected reduction in costs and improvements in the efficiency of the batteries used in the electric vehicles, the light and heavy freight transportation. As for the shipping, constraints were added to the model in order to increase the cost



competitiveness of the e-ferry. In terms of the whole energy system, the integration of renewable energy in this sector replaces the fossil fuels by electricity, with the transport passenger car sector being the most effective one with full electrification at the end of the horizon. With this integration of renewable energy in the transport sector, flexibility solutions are analysed. The analysis was focused on the V1G methods that are proposed by GIFT. It showed that V1G demonstrates the positive impact of the implementation of the cross-sectoral flexibility solution by introducing charging techniques that ensure it during off-peak hours while modulating the power of charging and meeting the demand of the prosumers. Nevertheless, engagement and raising awareness of the prosumers ought to be necessary for the success of this strategy during all timescales, to fully grasp the benefit of smart charging for the benefit of the energy system.

Storage is one solution used to provide flexibility and it is also connected with the EMS in this project. First finding concern the investment where storage solutions are in all cases more economical especially with the variability of the electricity prices implemented in the TIMES-Hinnøya model that try to approach the dynamics of the energy market. Hence, storage is encouraged during low prices. Two uses and technologies of storage were implemented. In the first case the HBr flow battery is applied in context of GIFT project the storage provides grid support as it is being used as part of the grid. The integration of storage in Harstad enables storing electricity at low prices of electricity so that it will be available when needed. For the second case, Li-ion batteries are used as distributed power. Coupled with wind energy, they are a prominent solution for the decentralization of the fish farms in Grytøya. They are implemented in the model for storing electricity from both wind during high production periods, and the grid during off-peak hours, and releasing during peak demand. They provide a solution for the decarbonization of this sector. Finally, the use of both of these storage technologies enhance harnessing the potential of renewable energy in case of investments in hydro and wind, with the decrease of imports from the main grid. However, in reality, the investment decisions in wind technologies would largely depend on the social acceptability as it raises concerns regarding the environment and biodiversity impact.

Similarly, to the case of Procida, the model is based on an economic optimization approach and consequently investment decisions are influenced by economic considerations. The use of fine timescales was helpful for visualizing and analysing the load curve for flexibility but this is a trade-off with the computational time for resolving the optimization problem. Reducing the timeslices alone allow catching the variability of the load and the value of flexibility but not operational constraints concerning frequency, voltage and stability of the energy system. Finally, the data availability plays an important role in defining the model's temporal and geographical resolutions.

8. CONCLUSIONS & RECOMMENDATIONS

Climate change mitigation measures include the reduction of greenhouse gas emissions (UN Environment, 2017), which translates in the decarbonization of the energy systems. In such a context, the increase in the share of renewable energy sources in the production mix appears to be a valid solution. First and foremost, these technologies can ensure energy production at low (or null) carbon emissions. Second, in terms of electric power generation, they represent fast-paced growing resources and finally, in many cases, have already become cost-competitive with fossil-fuel-based generation. The European Commission offers a favourable framework for the development of renewable energy, through the policy support of the Clean energy for all Europeans package where EU islands are specially concerned with this package with the dedicated initiative. Nevertheless, variable renewables have a stochastic nature, i.e. they depend on natural sources and weather which explains the growing need of flexibility. Power system flexibility does not have one specific definition but rather concerns many aspects of the system: the ability to maintain the system's stability, managing the variability and uncertainty of renewable energy and deal with the operation of the energy system with instantaneous stability and long-term security of supply and ensuring the balance between supply and demand.

In GIFT (*Geographical Islands Flexibility*), the main goal is to decarbonize the energy system of two demonstrator islands. With the consortium of the 17 partners, flexibility needs are addressed from an over-



all perspective straddling the operation and the planning of the energy system. In fact, solutions dedicated for flexibility support should be considered focusing on both the short-term with timescales of the minutes, and on the long-term with timescales of the months and years. The latter was the subject of the present study. With long-term prospective modelling using the TIMES model generator, discussion on the plausibility of the different possible future evolutions is enabled for least cost investments considering environmental and political constraints ending with recommendations for knowledge-based decision making for planning the evolution of the energy system. The ensuing recommendations for each island were presented in the dedicated long-term discussion for Procida (section 6.5) and Hinnøya island cluster (section 7.6) and comprehensive recommendations that are based on the results, research, analysis and participation in the project are detailed below.

Allowing higher shares of renewable energy in power systems of islands while meeting flexibility needs is dependent on the local context.

With the power system transformation towards integrating higher shares of renewable energy sources, the notion of flexibility becomes a central concern in studying energy systems. It is even more relevant in the case of islands where attention needs to be given on the physical and economic aspects. These territories are constrained with geographical limitation which reduces the variety of solutions available in the market to few ones that are adequate to the island's situation. For example, Procida is surrounded by a protected marine area which limits the energy sources to imports and solar photovoltaics on buildings. Their marginality also tends to increase the cost of investments in new solutions as they need to be specific to the context. In that sense, research and innovation plays an eminent role in pushing forward technological advancement, providing appropriate and cost-effective solutions. This aspect is promoted by the project GIFT through the targeted design and implementation of the solutions by the technology providers as per the specific requirements for the energy system of the demonstrators. This could not be done without the engagement of the local authorities who provide energy-related data and tangible information regarding the issues of the energy system and the collaboration between different entities which in turn builds up their capacities.

Analysing the decarbonization on the level of the whole energy system paves the way for examining the flexibility opportunities.

Several flexibility opportunities can be found in energy systems but they should go along the main target of decarbonization. Creating synergies between the sectors sheds the light on these possibilities. This was the case of the Norwegian lighthouse, where the electrification of the transport sector allows the integration of renewable energy coming from the grid. For the Italian lighthouse, the integration of renewable energy translates in investing in local resources through self-consumption via solar power to be used in the different sectors. Further to that, the way how islands acquire their electricity and energy services is important for studying energy systems of islands. We note that the islands presented similarities with their interconnection to the mainland and the inevitable dependency on imports through submarine cables. Increasing or decreasing this dependency is critical for determining the evolution of the energy system and the type and timing of new investments.

Necessity of involvement of the consumers that become “prosumers” thus participating in the energy transition.

Public and tertiary sectors are another source of demand-side flexibility on the islands as noticed by the use of the project's factory energy management system. The trend towards relying on electricity in the activities of these economic sectors is leading to harnessing the existing or new possibilities of flexible load. In general, this requires an increasing roll-out of smart meters, grid connected devices and the introduction of decentralized renewable energy and storage technologies, so that demand-side and thus “prosumers” participation is enhanced.

Permissible regulatory framework and the use of properly designed systems for demand-response are needed for the sustainability and replicability of the solutions.

The most suitable flexibility solution is dependent not only on the need, but also on situational restrictions and regulations. For enabling a long-term use of energy management systems, demand-response



mechanisms and the operation of storage devices that are key solutions of flexibility, are required to have proper legislation for the presence of aggregators with defined technical modalities, allowing the entry of the load produced by prosumers to compete with production assets in all markets. It is also enhanced by increasing the access of the participants to the auxiliary markets and balancing services, the wholesale market and to information about their consumption. However, these criteria are different from territory to another so they impact the replicability of the solutions.

Also, the technical modalities are another aspect for consideration in the scalability and replicability analysis (SRA) carried out by the task of WP9. We find a relevant example in the EU project InterFlex the concept of islanding by using micro-grid which was incorporated through the scalability and replicability analysis (SRA) of the French demo in the two islands of Lérins, which are located close to the main island of Cannes. (Herndler et al., 2020) The Lérins islands are connected to the mainland by submarine power cables, and it is not uncommon for them to be damaged by boat anchors. This causes power cuts on the islands, which handicap the local populations. (Meyer, 2020) With respect to islanding operation, the study included power generation (PV), storage capacity (consisting of Grid forming units GFU and Grid support unit GSU) and demand side management. The theoretical goal of islanding 21 days was shown to be achievable through the SRA but with a cost would be expensive for the islands. A possibility of 72 hours islanding was presented as least costly with scaling down the capacity of storage leaving the system reliable and avoiding blackouts until gensets are sent to islands in the case of emergency.



9. ANNEX I: TIMES PROCIDA – TECHNICAL DEVELOPMENT

9.1. MODEL DEVELOPMENT

9.1.1. General settings

Only one region is used to represent the entire energy system of the island.

The currency is set to Euro (€); the discount rate is 6%.

9.1.2. Time definition

The starting year of the model is 2018. A 32-years horizon is considered, up to 2050.

This period has been divided into sub-periods of 1 year each up to 2035, then the timestep becomes wider, as shown in *Figure 57*.

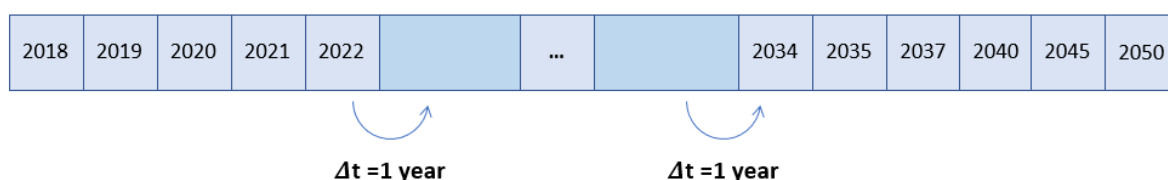

Figure 57. Time horizon breakdown representation

Each period is disaggregated into 15 time-slices, defined according to the season and time of the day. In particular, three different seasons are considered, namely *Winter*, *Summer* and *Intermediate*. The first one, that ranges from the 15th of November up to the 31st of March, is set according to an Italian decree²¹ that contains a definition of the buildings' heating period at different locations according to their climatic zone (Procida is in the climatic zone C). The *Summer* season ranges from the 15th of May to the 15th of September. This choice is based on the observation of the average irradiation values²² in Procida for different months of the year, that is the highest from April to September (see *Figure 58*). The *Intermediate* season corresponds to the rest of the year (1st of April-14th of May, 16th of September-14th of November).

²¹ DPR n. 412 del 26 agosto 1993

²² The considered radiation database is PVGIS-SARAH, as recommended by PVGIS for Procida's location (JRC, 2019a)

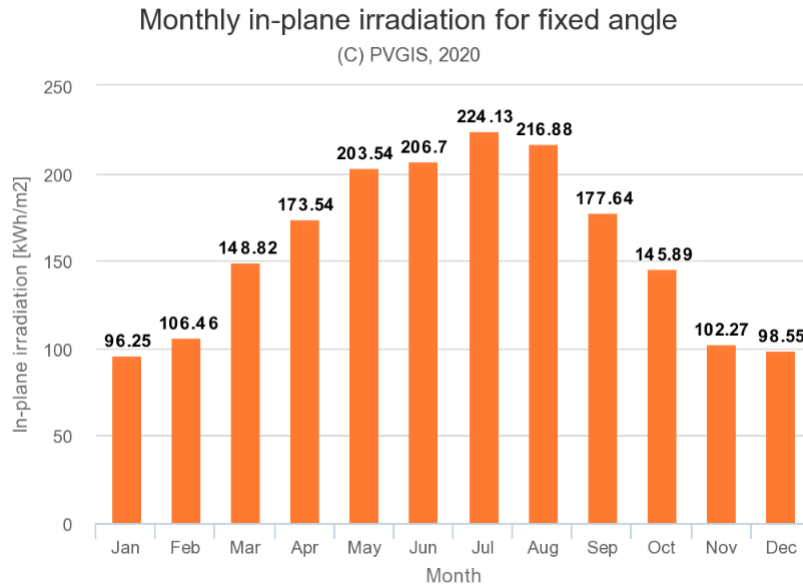

Figure 58. Mean monthly solar irradiation value on an optimally oriented PV in Procida (source: PVGIS (JRC, 2019b))

The definition of the time-slices on a daily basis is instead based on comparison between the annual average load curve of the residential sector (that is the most energy-intensive one in Procida) and the annual average global clear-sky irradiance curve for Procida, both of them defined on a daily basis.

For the calculation of the average annual solar irradiance on a daily basis, the global clear-sky irradiance is considered. This choice is made in order to avoid bias deriving from weather conditions variations at specific years. The data is provided by PVGIS tool on an hourly basis for each month of the year. The annual mean value at each hour i , G_{cs_i} , is then obtained as the average between the global clear-sky irradiance value of each month j :

$$G_{cs_i} = \frac{\sum_{j=1}^{12} G_{cs_{i,j}}}{12}$$

The methodology applied to obtain the annual residential load curve on a daily basis is instead detailed in section 9.2.1.

The comparison is graphically shown in **Figure 59**.

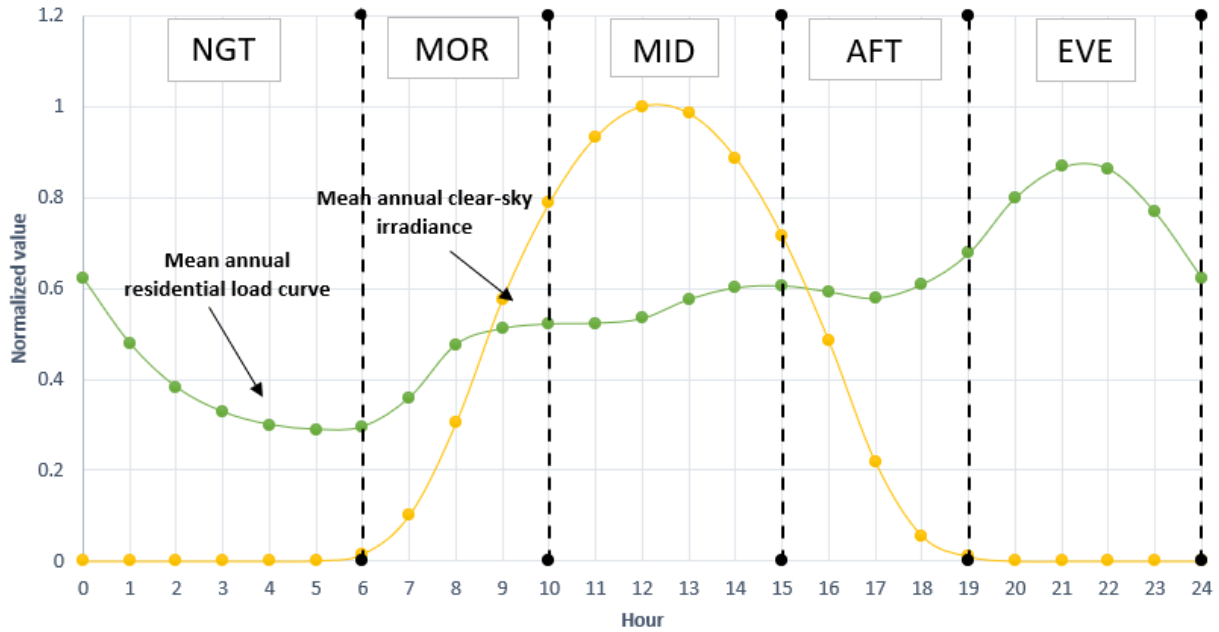

Figure 59. Comparison between the annual average clear-sky solar irradiance and the residential load curve on a daily basis (normalization with respect to the peak irradiance value)

9.2. BASE YEAR ENERGY SYSTEM

The reference energy system at the base year is defined based on the available data. For missing values hypothesis have been made, as explained in the following.

9.2.1. Demand side

Six different energy sectors are modelled, namely:

- Agriculture
- Industry
- Residential
- Tertiary
- Public
- Transportation

The public sector is independently modelled with respect to the tertiary one because for this sector more detailed data is available.

The definition of the consumption value at annual level and for each time-slice is obtained through hypothesis.

9.2.1.1. Estimation of the annual consumptions per sector

The data provided by E-Distribuzione only allows to differentiate between residential and non-residential users, without additional information on non-residential uses. The total consumption for the residential sector, E_{RES} , is then obtained from this data by subtracting the one for transportation (exclusively related to e-bikes in 2018, that are assumed to be only used by residential users):

$$E_{RES} = E_{RES+TRA} - E_{TRA}$$



Where $E_{RES+TRA}$ is the total energy consumption of residential users reported by E-Distribuzione, E_{TRA} is the total electricity consumption for e-bikes, estimated in section 9.2.1.7.

For the other sectors instead, additional hypothesis should be made. In particular, the estimation is based on some hypothesis made starting from the PAES of Procida, that contains information about the electricity consumptions of the island in 2010. The electricity consumption for the agriculture and industrial sector are assumed to be the same of the ones reported in the document. With this hypothesis, as the electricity consumption of the public sector are provided by the Municipality of Procida for 2018, the final electricity demand of the tertiary sector, E_{TER} , can be calculated as the difference with respect to the other sectors:

$$E_{TER} = E_{non-res} - E_{PUB} - E_{AGR} - E_{IND}$$

Where $E_{non-res}$ is the total electricity consumption of non-residential users, E_{PUB} is the electricity consumption of the public sector, E_{AGR} the one for agriculture, E_{IND} the one for industry.

9.2.1.2. Residential sector daily load variations

The load curve for the residential sector is obtained considering an average daily load curve defined for each of the seasons of the model.

For the definition of the load curve reference is made to statistically-based electricity load curves estimated for the residential sector in Italy in 2012

(Maggiore et al., 2012). In this study, the load curves are defined based on the day of the week (weekdays, Saturdays, Sundays and holidays) and the season of the year. As an example, the load curve for a weekday in different seasons is shown in **Figure 60**.

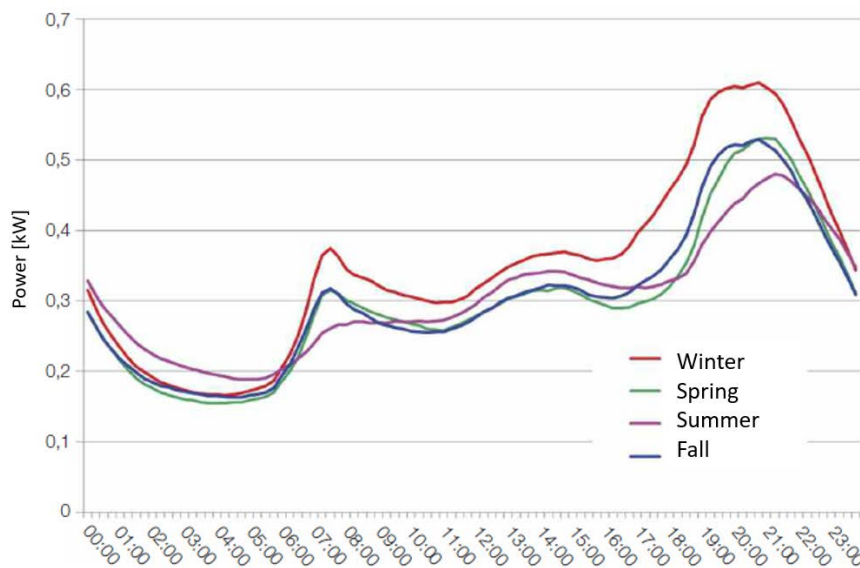

Figure 60. Italian typical residential load curve for a weekday and for different seasons (source: RSE (Maggiore et al., 2012))

For the purposes of the analysis, the load curves data is extracted and normalized with respect to the peak value. Then, the data is aggregated within the modelled seasons by taking into account an approximate number of weekdays, Saturdays, Sundays and holidays in one year.

The final load curve defined for each season of the model is shown in **Figure 61**.

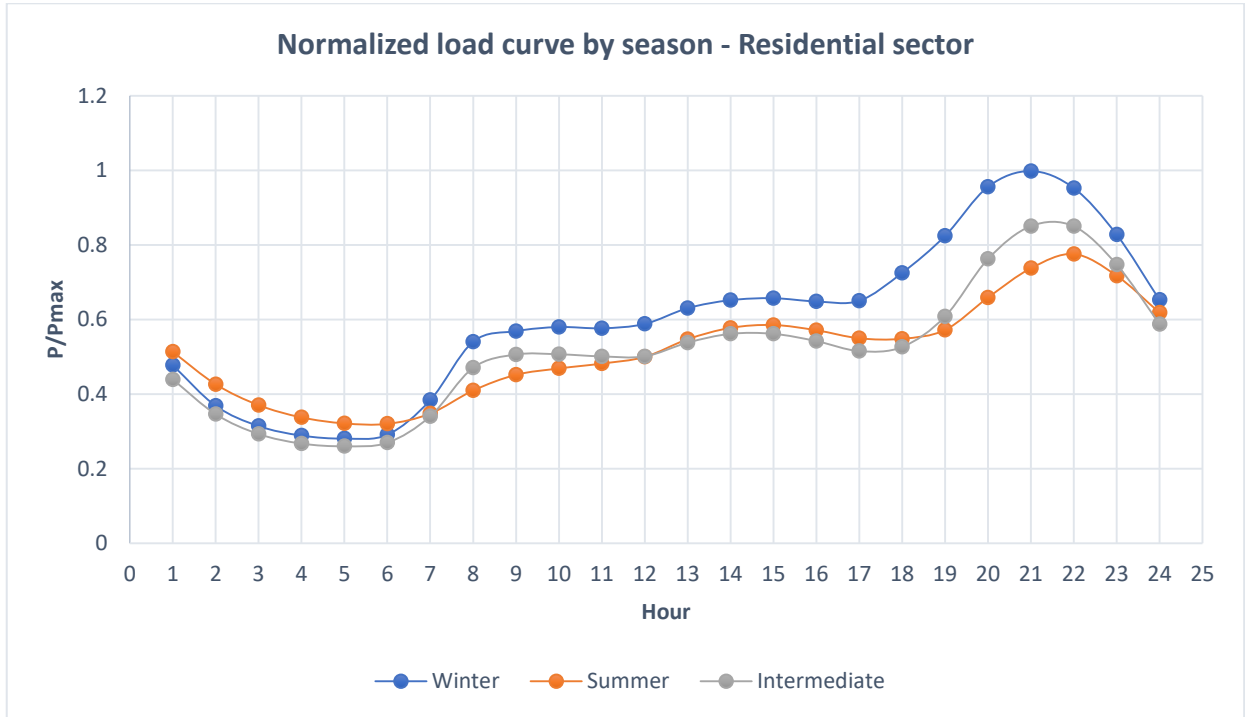

Figure 61. Residential load curve for different model seasons

As the load curve represents a daily power load, the energy consumption at each time-slice t , $E_{RES,j,t}$, is proportional to the integral of the load curve, that is:

$$E_{RES,j,t} = \int_a^b f_j(h) dh$$

Where a and b are the integration boundaries (that correspond to the first and last hour defining the time-slice), $f_j(h)$ is the electricity load curve in season j .

In practice, the curve was approximated to a piecewise linear function between all the hours of the day to estimate the energy quantity corresponding to each 1h-timestep. This is equivalent to calculate the area of a trapezoid. Then, the energy consumption was summed up over all the hours constituting the time-slice at each season. In mathematical terms:

$$E_{RES,j,t} = \sum_{h=a}^b \frac{[f_j(a) + f_j(b)] \cdot (b - a)}{2}$$

The fraction of energy consumption at each time-slice, $\%E_{RES,j,t}$, could then be estimated as:

$$\%E_{RES,j,t} = \frac{E_{res,j,t} \cdot N_j}{\sum_{j=1}^3 (\sum_{t=1}^5 (E_{res,j,t} \cdot N_j))}$$

With N_j the number of days in season j .

9.2.1.3. Tertiary sector daily load variations

A similar methodology is used to estimate the consumption fraction for the tertiary sector. In this case, for the evaluation of the electricity load curve trend reference is made to (GSE, 2019) for the seasonal variation and to (Hayes et al., 2013) for the daily variation. In particular, for the seasonal variation reference is made to an average statistically-based monthly electricity load curve in Italy. The graph, based on (GSE, 2019) is represented in **Figure 62**.

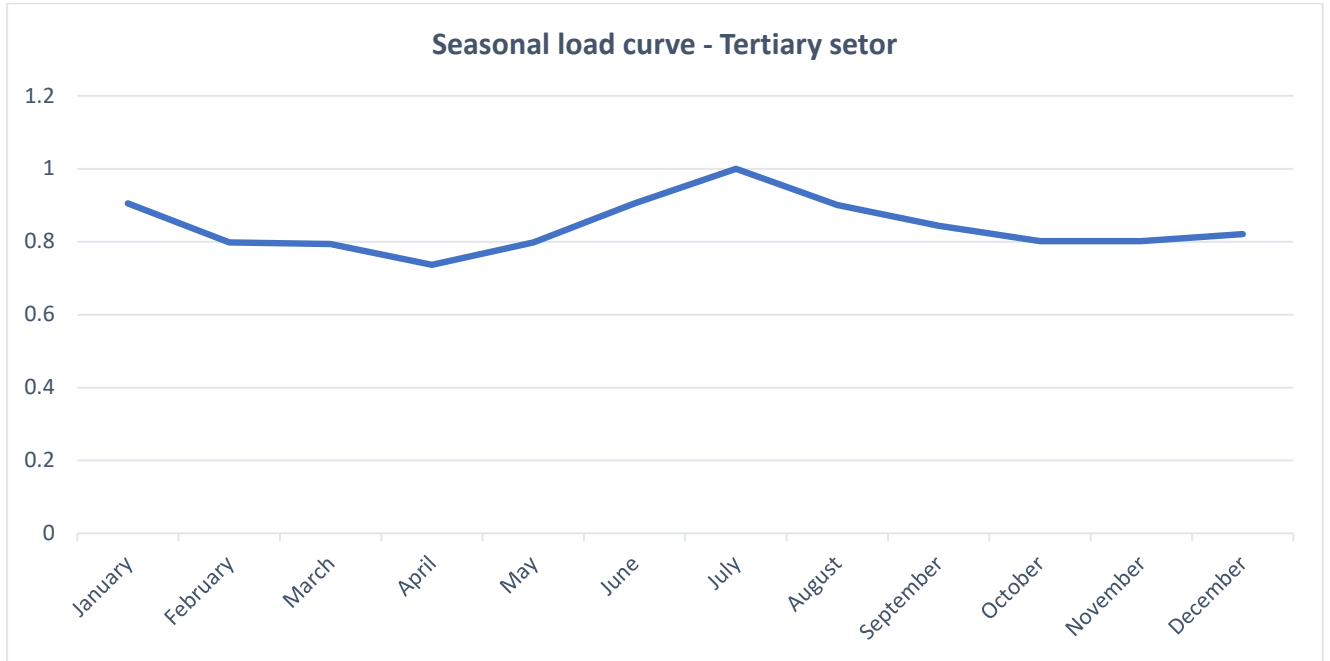

Figure 62. Seasonal load curve used for the tertiary sector (based on (GSE, 2019))

The monthly consumption given by this load curve is then aggregated to evaluate the total electricity consumption $E_{TER,j}$ at each season j defined in the model as it follows:

$$E_{TER,j} = \sum_{i=1}^m E_i \cdot f_{i,j}$$

Where E_i is the normalized electricity consumption at month i , m is the total number of months that are included in the season (ex. *Winter* includes the months from November to March), $f_{i,j}$ is the fraction of days that are included the season definition for each specific month (ex. *Winter* only includes 16 days in November, so $f_{1,Winter} = 0.533$).

The fraction of consumption at each season is then calculated with respect to the total annual consumption:

$$\%E_{TER,j} = \frac{E_{TER,j}}{\sum_{j=1}^3 E_{TER,j}}$$

To define the time-slices at daily level instead, reference is made to a statistically-based annual electricity load curve in England provided by (Hayes et al., 2013) on a daily basis (no information was found for the Italian daily trend). The normalized daily trend is shown in **Figure 63**.



Figure 63. Annual load curve on daily basis used for the tertiary sector (based on Hayes et al., 2013)

The daily energy consumed at each time-slice t , $E_{TER,t}$, is calculated by summing up all the 1h-timestep and electricity consumptions by approximation of the load-curve to a piecewise linear function, as made in the case of the residential sector. The fraction of consumption in each daily time-slice is then evaluated with respect to the total consumption during the day:

$$\%E_{TER,t} = \frac{E_{TER,t}}{\sum_{j=1}^{24} E_{TER,t}}$$

The fraction of consumption at each time-slice is then given by the product between the fraction of consumption at seasonal level and the one evaluated on a daily level:

$$\%E_{TER,j,t} = \%E_{TER,j} \cdot \%E_{TER,t}$$

9.2.1.4. Public sector daily load variations

For the public sector data concerning the electricity consumption of public buildings, public lighting, sewers and traffic lights is available.

However, only for some public buildings and sewers the consumption is available on hour basis; for the others data is expressed according to a specific daily time slots defined based on different electricity tariffs (named F1, F2, F3 and corresponding to peak and off-peak electricity demand hours²³). For the first ones, the consumption fraction at each time-slice is calculated as a percentage of the total annual consumption. When hourly data is missing instead, the consumption is proportional to the length of time-slice and evenly assigned to each season.

For the City hall, that has a PV installation on the roof, the total consumption is evaluated as the sum of the measured consumption and the PV electricity production.

9.2.1.5. Industrial sector daily load variations

²³ As established in the ARERA deliberation, *Deliberazione 9 maggio 2008 - ARG/elt 56/08*



The industrial sector load is only defined at annual level by setting the total consumption in the year, whereas no variations in the load are taken into account at daily or seasonal level. The electricity consumption in each time-slice is then proportional to the length of the time-slice itself.

9.2.1.6. Agriculture daily load variations

For the primary sector no variations in the load are taken into account at daily or seasonal level, as for the industrial sector. Even in this case then, the electricity consumption in each time-slice is proportional to the length of the time-slice itself.

9.2.1.7. Transportation demand

At the reference year only electric bikes, that according to Procida's municipality represent an important fleet in the island, are modelled. As no information about the electricity consumption is available, the estimation of the electricity consumption for this means of transport is based on several hypothesis.

First of all, it is assumed that all the bikes use a standard battery having the following characteristics (McCarran et al., 2018) : 36 V and 12.75 Ah, 5 hours for a full charge of the battery, 85% efficiency at the charge. In addition, it is considered for each of the bikes an average daily distance travelled of 6.4 km/day with an average consumption of 6.2 Wh/km (McCarran et al., 2018).

For the estimation of the electricity consumption from e-bikes, the behavior of the users should be taken into account too. Some studies, such as in Gorenflo et al., 2017 and (Rios, 2016), which analyze the users behavior in terms of bicycles' battery management, show that people tend to charge their battery even if it is still at more than 90% (**Figure 64**).

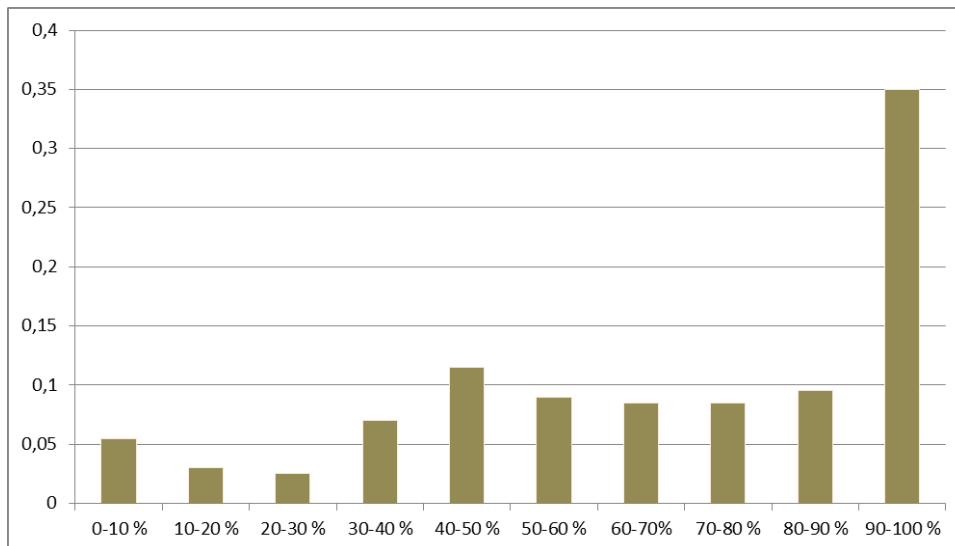

Figure 64. Statistical distribution of the beginning of charge with respect to the battery state of charge

Moreover, according to (Rios, 2016), there is a tendency to stay plugged in for a long time or to do a quick charge in less than an hour (see **Figure 65. Charging time distribution**).

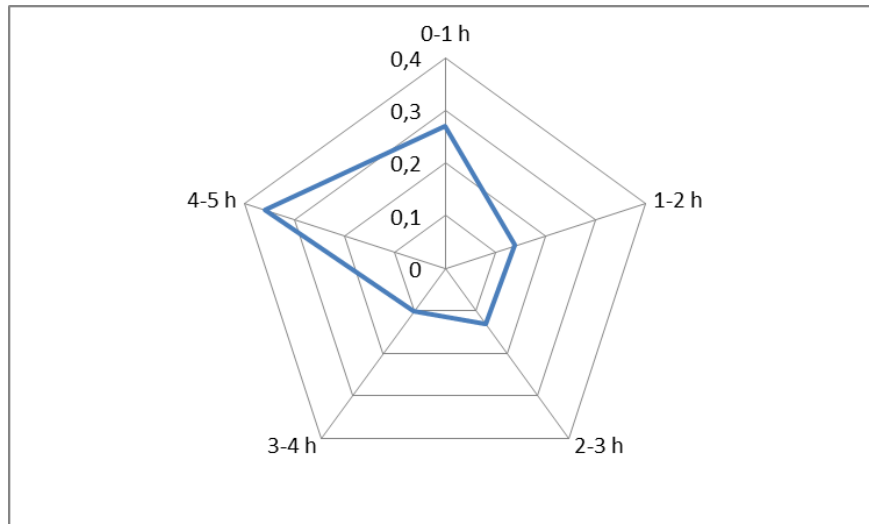

Figure 65. Charging time distribution

It is therefore possible to estimate the distribution of the number of people according to the state of charge of the battery and the recharge time. However, this is made under the (not empirically verified) assumption that the charging time was independent of the battery charge level at the time of connection.

Based on Efaz et al., 2017, the percentage of charge is not linear over time (i.e. the battery recharges more quickly when it is empty, as shown in Figure 66). It is possible to determine for each of the following cases the charging capacity of the battery at the end of charging (Figure 67).

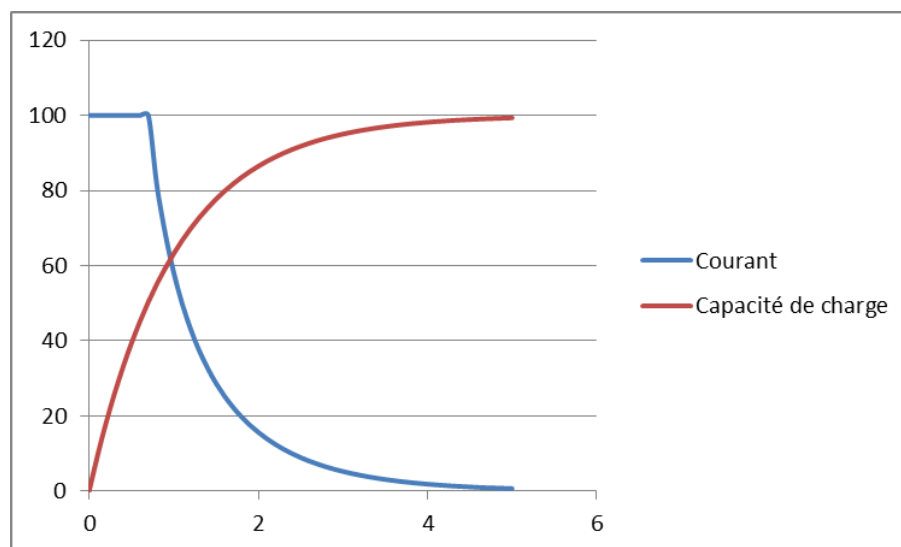

Figure 66. Charging capacity and current in percentage, as a function of the charging time



	0-1 h	1-2 h	2-3 h	3-4 h	4-5 h
0-10 %	0,63	0,86	0,95	0,98	0,99
10-20 %	0,69	0,88	0,95	0,98	0,99
20-30 %	0,72	0,9	0,96	0,98	0,99
30-40 %	0,77	0,92	0,97	0,987	0,99
40-50 %	0,8	0,92	0,97	0,99	0,99
50-60 %	0,83	0,93	0,98	0,99	0,99
60-70 %	0,87	0,95	0,98	0,99	0,99
70-80 %	0,9	0,96	0,99	0,99	0,99
80-90 %	0,94	0,97	0,99	0,99	0,99
90-100 %	0,98	0,99	0,99	0,99	0,99

Figure 67. Battery state of charge at the end of charging depending on the state at the beginning of the charge

By noting E_0 the state of charge of the battery at the start of charging (different values have been considered, such as 5%, 15%, 25%, etc.) and by noting \check{E} the state of charge at the end of charging, for each of the cases the following calculation was performed:

$$E_{c,i} = 12,75 \times 36 \times (\check{E} - E_0)$$

which allowed to determine the electricity consumption $E_{c,i}$ in each case (Figure 68).

	0-1 h	1-2h	2-3 h	3-4 h	4-5 h
0-10 %	266,22	371,79	413,1	426,87	431,46
10-20 %	247,86	335,07	367,2	380,97	385,56
20-30 %	215,73	298,35	325,89	335,07	339,66
30-40 %	192,78	261,63	284,58	292,383	293,76
40-50 %	160,65	215,73	238,68	247,86	247,86
50-60 %	128,52	174,42	197,37	201,96	201,96
60-70 %	100,98	137,7	151,47	156,06	156,06
70-80 %	68,85	96,39	110,16	110,16	110,16
80-90 %	41,31	55,08	64,26	64,26	64,26
90-100 %	13,77	18,36	18,36	18,36	18,36

Figure 68. Consumption (in Wh) depending on the starting charge level and charging time

In addition, considering a consumption of 6.2 Wh/km and an average daily distance of 6.4 km/day, it was possible to determine the number of days of use before charging and therefore the average number of charges per month for each case (Figure 69).



	Nombre de jours avant charge	Nombre de charges en moyenne par mois
0-10 %	10,98916331	2,767878301
10-20 %	9,832409274	3,093511043
20-30 %	8,675655242	3,505979182
30-40 %	7,51890121	4,045360594
40-50 %	6,362147177	4,780880702
50-60 %	5,205393145	5,843298636
60-70 %	4,048639113	7,512812532
70-80 %	2,891885081	10,51793755
80-90 %	1,735131048	17,52989591
90-100 %	0,578377016	30,41666667

Figure 69: Number of days of use before loading

It is assumed that the number of bikes is 3400 in the summer (when the peak of tourism occurs) and 1000 during the rest of the year. Moreover, assuming that the number of bicycles in use is linearly correlated to the number of tourists (data referring to Italy (ISTAT, 2019b), it was possible to evaluate the number of bicycles in circulation per month (**Figure 70**).

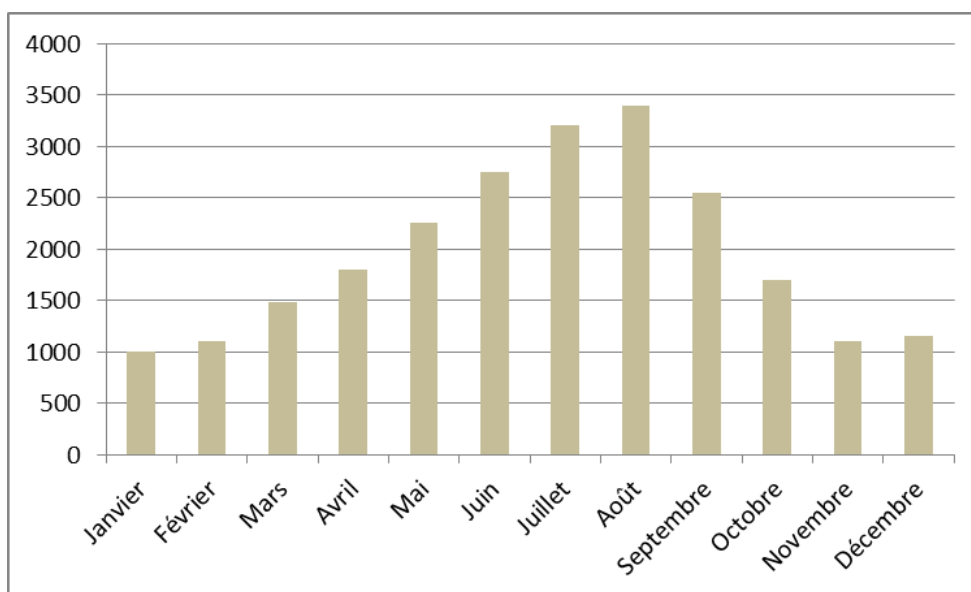

Figure 70. Number of bikes in circulation per month

Using the distribution of the beginnings of charge versus the charge rates (**Figure 64**), the number of charges per month (**Figure 69**), the consumption in Wh as a function of the starting charge level and charging time and taking into account a charging efficiency of 85%, we were able to build a monthly demand for electricity (**Figure 71**).

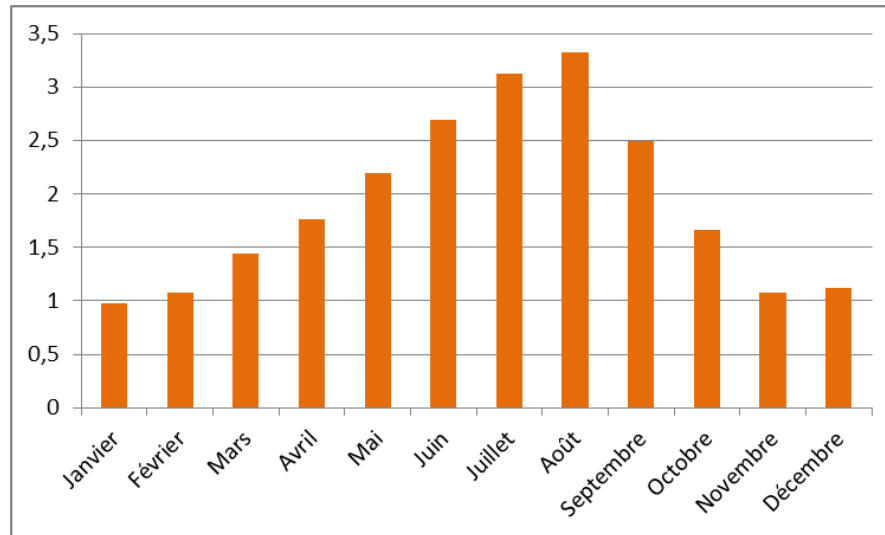

Figure 71. Monthly consumption (in MWh) for electric bikes mobility

The electricity consumption is linearly correlated to the number of bicycles in the island, since no distinction between the behavior of the local population and tourists is made. The annual electricity demand for electric bikes that is obtained with this methodology is then 33,4 MWh.

It should be noticed that the degradation of the battery is not taken into account in the modeling (ex: loss of 30% of the total capacity of the battery after 500 charges (Efaz et al., 2017)).

9.2.2. Supply side

At the reference year the only technology installed on the island for energy production is photovoltaics, namely in private and public buildings. However, the energy produced by this source only covers about 1% of the demand; the rest is supplied by the electric grid that connects the island with the mainland.

9.2.2.1. Photovoltaics installations

The photovoltaics are separately modelled for the residential, tertiary and public sector, in order to better evaluate the contribution of this technology to the supply of each of them. As no information on the date of installation is available, it is assumed that they have a lifespan of 20 years and that the technology activity linearly decreases with the passing of time.

The data provided by E-Distribuzione only concern the annual energy output (in kWh) of each installation and their rated power.

For the purposes of the model, the capacity factor of each PV should be defined at each time-slice. This is made starting from the definition of this quantity²⁴:

$$CF = \frac{E}{E_{\max}}$$

With E the net electricity generated by the system, E_{\max} the energy that could have been generated at continuous full-power operation considering the same period of time.

▪ E calculation

²⁴ Based on US NRC definition: <https://www.nrc.gov/reading-rm/basic-ref/glossary/capacity-factor-net.html>



The quantification of the energy output of the system at each time-slice is based on the assumption of an optimally-oriented crystalline silicon PV installation with unitary rated power ($C_{PV} = 1 \text{ kW}_p$) and a system loss of 14%.

First of all, the monthly average energy output (in kWh) in Procida is obtained using the PVGIS tool (**Figure 72**). This data is then aggregated for all the seasons considered in the model by summing up the energy output of each month constituting the season, E_j (it is assumed that the energy output at each day of a month is constant).

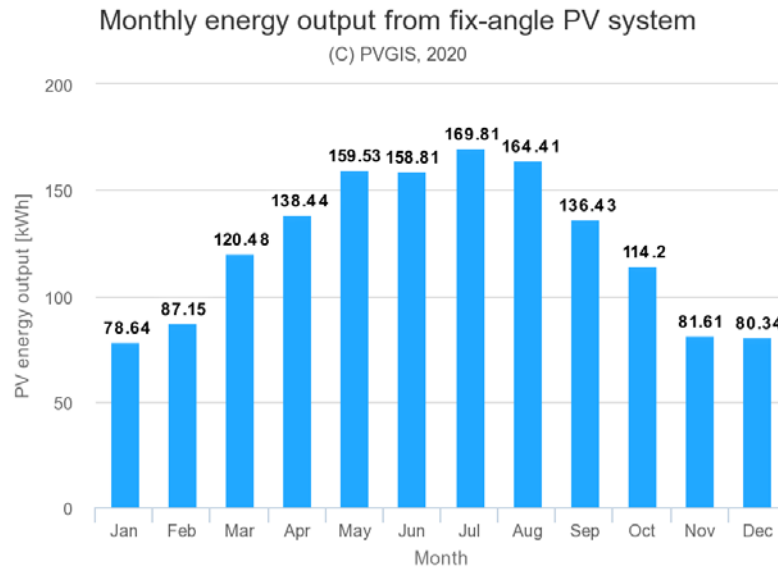

Figure 72. Monthly energy output from a fix-angle PV system in Procida(JRC, 2019b) (JRC, 2020b)

The estimation of the energy output in each time-slice is then made considering the direct irradiance, G_b , again obtained using PVGIS for a fixed plane. This value is firstly obtained for each considered season and for each hour of the day by aggregating the values provided by PVGIS for each month of the year.

Assuming that the energy output is proportional to the direct irradiance, the fraction of energy production in a specific time-slice t and season j , $\%E_{t,j}$, is estimated as:

$$\%E_{t,j} = \frac{\sum_{i=1}^n G_{b_i}}{\sum_{i=1}^{24} G_{b_i}}$$

With G_{b_i} the direct irradiance at the hour i , n the number of hours constituting the considered time-slice.

The energy output in each time-slice and for each season is then obtained by multiplying the total energy output estimated with PVGIS in each season j , E_j , for the fraction of energy production, $\%E_{t,j}$:

$$E_{t,j} = \%E_{t,j} \cdot E_j$$

▪ **E_{max} calculation**

E_{max} is calculated for each time-slice t as the product between the number of hours constituting the time-slice, h_t , and the rated power of the installation:

$$E_{max} = C_{PV} \cdot h_t$$



For the imports no variations in the electricity price during the day are considered. This choice is made to avoid bias in the results due to economic advantages in specific hours of the day. The price is fixed to 184.7 €/MWh, resulting from the average between the mean final electricity price for residential (216.9 €/MWh) and non-residential users (152.5 €/MWh) in 2018 as provided by ARERA, 2019.

9.3. ENERGY SYSTEM EVOLUTION

Different assumptions are made to take into account the evolution of the energy system in time. These hypothesis concern both the demand and supply side.

9.3.1. Demand projection

The electricity demand for a given sector and at a given year t , D_t , is calculated as:

$$D_t = D_{t-1} \cdot \left(1 + \frac{GDP_t - GDP_{t-1}}{GDP_{t-1}}\right)$$

Where D_{t-1} is the electricity demand at $t-1$, GDP_t and GDP_{t-1} the GDP value at year t and $t-1$, respectively.

9.3.2. New technologies

Several new technologies are included in the model, namely:

- New PV installations
- Li-ion batteries
- Smart Energy Hub (system developed within the GIFT project)
- rSOC storage
- Electric vehicles

The modelling approach for each of them is detailed in the following.

9.3.2.1. New photovoltaics installations

It is assumed that the PV installations for all the sectors are built in crystalline silicon (in Italy 94% of PV installations are made in silicon (GSE, 2019)) and that they have an unitary nominal capacity (1 kWp), with system losses are equal to 14%.

The lifespan is fixed to 30 years (IRENA, 2019). For the investment cost, the price is assumed to decrease with time. The value in 2018 is set according to (IRENA, 2020), the one in future years according to IRENA, 2019. The operation and maintenance costs are instead assumed to be constant in time and fixed according to (IRENA, 2020).

It is assumed that all the new PVs are installed with an optimal slope and plane orientation (35° and 0° in Procida, respectively²⁵). With this hypothesis, the capacity factor at each time-slice is estimated using the same methodology applied for the existing PV installations and detailed in section 9.2.2.1.

The summary of the parameters used to model the new photovoltaics installations is summarised in **Table 13**.

²⁵ Values obtained with PVGIS simulations in Procida



Parameter	Value
Life	30 years
Investment costs	<i>Residential:</i> 2018: 1374 €/kW 2030: 750 €/kW 2050: 433 €/kW <i>Tertiary/public:</i> 2018: 1060 €/kW 2030: 530 €/kW 2050: 291 €/kW
Fixed O&M costs	8.58 €/kW
Capacity factor	According to solar irradiance (see 9.2.2.1)

Table 13. Summary of the input parameters for new PV installations

9.3.2.2. Li-ion batteries

Li-ion batteries are coupled to photovoltaics to better manage the energy potential of the solar installation. This device is modelled in TIMES as a *standard timeslice storage* process operating at daynite level. Three different Li-ion battery technologies are defined, one for each of the sectors that have photovoltaics installed on buildings.

It is assumed that new investments for this technology will only be available starting from 2020.

The lifespan of all the batteries is set to 10 years in 2020, based on the average value indicated in EASE, 2020. As technology improvements are expected for this technology (Tsiropoulos et al., 2018), the lifetime of the system is increased to 15 years in 2030 (IRENA, 2017). The investments costs are separately defined for residential applications and public and tertiary ones. Moreover, as the investment costs are expected to decrease in the near future, different values are defined for different years. Both for the definition of the costs and their evolution up to 2040 reference is made to Tsiropoulos et al., 2018. As the analysis considers different scenarios of Li-ion batteries penetration in the market, reference is made to the values for a moderate deployment of these systems. It is assumed that for residential applications the batteries have a C-rate²⁶ equal to 0.35; for the tertiary and public one instead the C-rate is assumed to be 0.25. For 2050 instead, a hypothesis is made on the investment costs (about 288 €/kWh for residential applications, 180 €/kWh for tertiary and public ones). No fixed operation and maintenance costs are considered for batteries.

Finally, it is assumed that the cost of the battery is equal to the cost of the entire battery system. However in general the battery energy system cost breakdown other costs should be considered (Tsiropoulos et al., 2018). These additional costs are not taken into account as they are system-specific.

Table 14 contains a summary of the inputs used to model li-ion batteries.

²⁶ The C-rate represents the discharge rate of a battery. *The capacity of a battery rated at 1C means that a fully charged battery will be completely discharged in 1 hour. 2C rate means that the battery can be fully discharged in half an hour. ½C rate means that the battery can be fully discharged in 2 hours.* (JRC, 2020a)



Parameter	Value
Max capacity per installation	Residential: 25 kWh Tertiary/public: 50 kWh
Life	2020: 10 years 2030: 15 years
Investment costs	<i>Residential:</i> 2020: 590 €/kWh 2025: 486 €/kWh 2030: 427 €/kWh 2035: 354 €/kWh 2040: 313 €/kWh 2050: 288 €/kWh <i>Tertiary/public:</i> 2020: 393 €/kWh 2025: 323 €/kWh 2030: 284 €/kWh 2035: 233 €/kWh 2040: 206 €/kWh 2050: 180 €/kWh
Efficiency	2020: 92% 2030: 94%
Capacity factor	According to solar irradiance (see 9.2.2.1)

Table 14. Summary of the input parameters for new Li-ion battery installations

9.3.2.3. Smart Energy Hub

The Smart Energy Hub is a hybrid system composed by two different technologies, namely a rSOC (reversible Solid Oxide Cells) and a Li-ion battery. According to the project planning, the system will be installed in the city hall building by June 2021; consequently, in the model, the technology is only taken into account starting from 2022.

The input parameters used for the modelling of the system are chosen according to the technical parameters provided by the technology developer, Sylfen. All the parameters are summarised in **Table 15**.

	Smart Energy Hub (SYLFEN)	
	rSOC	Battery



	electrolysis mode	fuel cell mode	
Materials	max storage: 50 kg of compress hydrogen 200 bar		Li-Ion
Capacity (kW)	11-40 kW _e + 4 kW _{th} (produced, max)	1.6 to 5 kW _e + 4 kW _{th} (produced, max)	maximum peak charge/discharge power of +/-50kW permanent charge/discharge power of +/- 25kW
Energy (kWh)	1970 (possibility to have 0% of state of charge)		50 kWh (but useful capacity of 40 kWh) (keep 10% of state of charge in order to avoid deep discharge)
Efficiency (-)	75% electrical 80% thermal + electric	50%	90%
Ramp constraints (p.u. per min)	Switching time between power set point lower than 10' but must remain stable for 1 hour (thermal stability is required)		Fast switching between power set point including charge and discharge switching mode. The switching time is of some seconds
Lifetime (years)	20 years (expected)		5 years at the time of installation 10 years expected in 2025 with technology development
Max cycles	No limitations except that it is not possible to change the mode more than 6 times per day		1 cycle per day preferably, 2 cycles possible if not complete discharge to DoD
Losses	Negligible		Negligible
Energy cost (€/kWh)	76 €/kWh		
Capacity cost (€/kW)	1700 €/kW in charging mode 2780 €/kW in discharging mode		

Table 15. Summary of technical characteristics of the Smart Energy Hub

Each component of the rSOC system (electrolyser, H₂ tank, fuel cells) has been separately modelled in TIMES. The H₂ tank represents the core of the system and it is modelled as a storage process. The other components have instead been defined as general processes. A schematic representation of the system model and flows is shown in *Figure 73*.

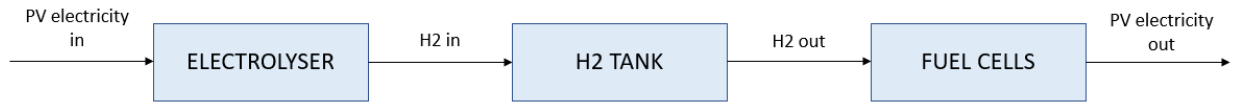

Figure 73. Schematic representation of the rSOC component of the Smart Energy Hub in TIMES

The cost of the technology provided by Sylfen refers to the total system, composed by the rSOC and the battery. To estimate the cost of the rSOC (composed by the electrolyser, the H2 tank and fuel cells), a split is made with respect to the cost of Li-ion batteries. Assuming a cost of 1000 €/kWh for the Li-ion battery (average between the price values indicated by EASE²⁷ in EASE, 2020), the cost of the rSOC is calculated according to the following equation:

$$c_{Li-ion} \cdot C_{Li-ion} + c_{rSOC} \cdot C_{rSOC} = c_{SEH} \cdot C_{SEH}$$

With c_{Li-ion} and c_{rSOC} the cost of the Li-ion battery and rSOC per unit of energy (€/kWh) respectively, C_{Li-ion} and C_{rSOC} the capacity of the Li-ion battery and rSOC (expressed in kWh), c_{SEH} the total cost of the Smart Energy Hub per unit of energy (€/kWh), C_{SEH} the total capacity of the Smart Energy Hub (in kWh).

The price of the rSOC, c_{rSOC} , is thus estimated to 52.55 €/kWh.

In order to avoid the investment of the model only on one of the components, the total cost of the system is evenly assigned to the electrolyser and the fuel cell, setting the cost of the H2 storage system to 0 €/kWh.

As no additional information is provided, the performance of the technology in terms of efficiency is assumed to remain constant in time.

9.3.2.4. Long-term (rSOC) storage

The rSOC storage is also considered as a separate technology that can operate at a seasonal level, giving the possibility to “shift” the electricity supply from one season to another. In TIMES, it is modelled as a *standard timeslice storage* process operating at seasonal level.

The technical characteristics of this technology are defined on the basis of the ones used for the rSOC of the Smart Energy Hub. However, in this case the system is modelled as a unique process, with an efficiency η_{LTSTG} that is given by the product between the one of the electrolyser, η_{elysr} , and the one of the fuel cell, η_{FC} :

$$\eta_{LTSTG} = \eta_{elysr} \cdot \eta_{FC}$$

A summary of the values used to model the technology is shown in **Table 16**.

²⁷ European Association for Storage of Energy



Parameter	Value
Life	20 years
Efficiency	37.5%
Investment costs	52.55 €/kWh

Table 16. Summary of the input parameters for new seasonal storage installations

9.3.2.5. Electric vehicles

Electric vehicles are included in the model as additional consumption demands for the transportation sector. The investment costs, the fixed and variable costs for this technology are set to zero.

It is chosen to model electric cars and electric motorcycles, because these types of vehicles represent the most numerous ones in the island (4443 cars and 3096 motorcycles (ACI, 2019)).

For the estimation of the additional electricity demand of each type of new vehicle different hypothesis are made. For electric cars, the consumption per unit of distance is assumed to be 0.2 kWh/km, (Pasaoglu et al., 2013) is the max electricity consumption for this type of vehicle. The average distance travelled per day is set to 10 km, based on the fact that statistically in Italy more than 75% of the displacements are less that distance (ISFORT, 2019). Concerning the battery capacity, it is defined an increasing value with time, given the expected technology improvements in the near future. The values are set according to IEA, 2020. Assuming that the e-cars fleet is only used by residential users, the charging station capacity is typically a slow charging one. The capacity is then set to 3.5 kW (Azzone et al., 2016).

The main technical assumptions for electric cars are shown in **Table 17**.

Electric cars modelling - main hypothesis	
Consumption [kWh/km]	0.2
Distance per day [km]	10
Charging station capacity [kW]	3.5
Battery capacity [kWh]	2020: 35
	2025: 50
	2030: 75
	2040: 80

Table 17. Summary of the hypothesis made for the electric cars' technical parameters

Similar hypothesis is made for the electric motorcycles (cf. **Table 18**). However, in this case the electricity consumption per unit of distance is lower, still based on (Pasaoglu et al., 2013). In this case no battery capacity improvements are considered.

Electric motorcycles modelling - main hypothesis
--



Consumption [kWh/km]	0.13
Distance per day [km]	10
Charging station capacity [kW]	3.5
Battery capacity [kWh]	15

Table 18. Summary of the hypothesis made for the electric motorcycles' technical parameters

Starting from these assumptions the additional electricity load can be defined by defining the deployment scenario (number of vehicles, travel routine, battery state of charge at depart, users charge behaviour). The calculation, based on the hypothesis of one charge per day, is explained in the following.

First of all, the electricity consumption per EV i and per day d , $E_{EV,i,d}$, is determined:

$$E_{EV,i,d} = c_i \cdot d_i$$

With c_i the specific electricity consumption (kWh/km) and d_i the distance travelled per day.

Then, the electricity consumption of the total fleet per day, $E_{EV,d}$, is estimated by considering the number of deployed EV:

$$E_{EV,d} = E_{EV,i,d} \cdot SH_d \cdot n_{EV}$$

With SH_d the share of EVs used per day, n_{EV} the number of EVs present on the island.

The EVs electricity load is defined both for peak and off-peak consumption periods. For the peak period the daily load $E_{EV,peak,d}$ is defined as:

$$E_{EV,peak,d} = E_{EV,d} \cdot SH_{peak}$$

With SH_{peak} the share of EVs that are charged at the peak electricity consumption period.

The same applies for the daily off-peak period consumption, $E_{EV,offpeak,d}$:

$$E_{EV,offpeak,d} = E_{EV,d} \cdot SH_{offpeak}$$

With $SH_{offpeak}$ the share of electric vehicles recharged in the off-peak period ($SH_{offpeak} = 1 - SH_{peak}$).

Finally, the annual consumption can be estimated both for the peak and off-peak period as:

$$E_{EV,peak} = E_{EV,peak,d} \cdot 365$$

$$E_{EV,offpeak} = E_{EV,offpeak,d} \cdot 365$$

For the definition of the EVs electricity load at each time-slice it is assumed that only one recharge per day occurs. With this hypothesis, different scenarios could be defined according to the users charge behaviour. This is equivalent to define the share of EVs charged at each time-slice.

The time-slice consumption fraction at each time-slice t , $\%E_{EV,t}$, is defined as:

$$\%E_{EV,t} = \frac{(SH_{t,peak} \cdot E_{EV,peak,d} + SH_{t,offpeak} \cdot E_{EV,offpeak,d}) \cdot N_j}{E_{EV,peak} + E_{EV,offpeak}}$$

With $SH_{t,peak}$ and $SH_{t,offpeak}$ the share of electric vehicles charged at the time-slice t of the peak and off-peak period respectively, N_j the number of days in the considered season j .



9.4. SCENARIOS DEFINITION

At a first attempt, two main scenarios are considered in the analysis, namely a case with low photovoltaics penetration (*LOW*) scenario and a scenario with higher PV penetration (*HIGH*). Then, two additional scenarios are considered: one in which storage technologies are included in the model (*HIGH_STG*) and another one in which efficiency policies are included as well (*HIGH_STG_EFF*).

The calculations made to define these scenarios in the model are presented in the following.

9.4.1. Annual photovoltaics investments

To avoid excessive investments on photovoltaics at a given year, annual growth rate constraints are included in the model. In particular, a constraint on the maximum amount of PVs installations $N_{max,t}$ is set at each year t of the horizon according to the following equation:

$$N_{max,t} = c_t$$

Where c_t is the integer value defining the maximum amount of new photovoltaics installations at year t .

The different bound values c_t used to define the two PVs deployment scenarios (*LOW* and *HIGH*) are shown in **Table 19**.

Table 19. Summary of the values used to define the constraints on maximum annual PV investments

Year	LOW [kW/year]	HIGH [kW/year]
2018-2020	50	50
2020-2025	80	150
2025-2030	80	200
2030-2040	100	250
2040-2050	120	300

The value set for 2018-2020 is set in accordance with the observations on the Italian capacities trend, that increased quite linearly between 2013 and 2018 (see **Figure 74**) and knowing that 97.5% of the installations are connected to the low voltage grid (GSE, 2019). The reference values used to obtain the trend are the capacities installed in 2013 (57.6 kW)²⁸ and 2018 (268 kW). The values start to differ instead from 2020.

²⁸ The information about the capacity installed in 2013 in Procida is available at <http://atlasole.gse.it/atlasole/>



Figure 74: Evolution of photovoltaics installations in Italy (source: GSE, 2019)

9.4.2. Annual PV investments by sector

In both scenarios an additional constraint on the maximum share of new installations per sector is imposed. In particular, it is assumed that 100% of the new installations can be residential, whereas for the other sectors it is 40%. This is made to make the model more realistic, still ensuring the optimization of the PVs mix in time.

Mathematically, the equation of the constraint is the following:

$$N_{max,s,t} = c_t \cdot SH_{PV,s}$$

Where $N_{max,s,t}$ is the integer value of maximum new photovoltaics installations for the sector s at year t , $SH_{PV,s}$ is the maximum share of new investments on PVs used to supply the sector s .

9.4.3. Efficiency improvement

Efficiency improvements for the residential and tertiary sector are taken into account to define the *HIGH_STG_EFF* scenario. From the modelling point of view, this is equivalent to a decrease in the electricity demand according to a fixed decrease coefficient with respect to the reference year in which energy efficiency policy is applied.

In mathematical terms, the new electricity demand, D'_t , is given by the equation:

$$D'_t = D_t - D_t \cdot d_t \cdot (t - t_{ref})$$

Where D_t is the electricity demand at year t , d_t is the electricity decrease coefficient, t_{ref} is the reference year.

As an example, the comparison between the electricity load with efficiency policies and without them in the tertiary sector is shown in *Figure 75*. In this case, it is assumed a consumption decrease of 0.25% with respect to the one in 2020 for 10 years and a decrease of 0.10% with respect to the one in 2030 for 20 years.

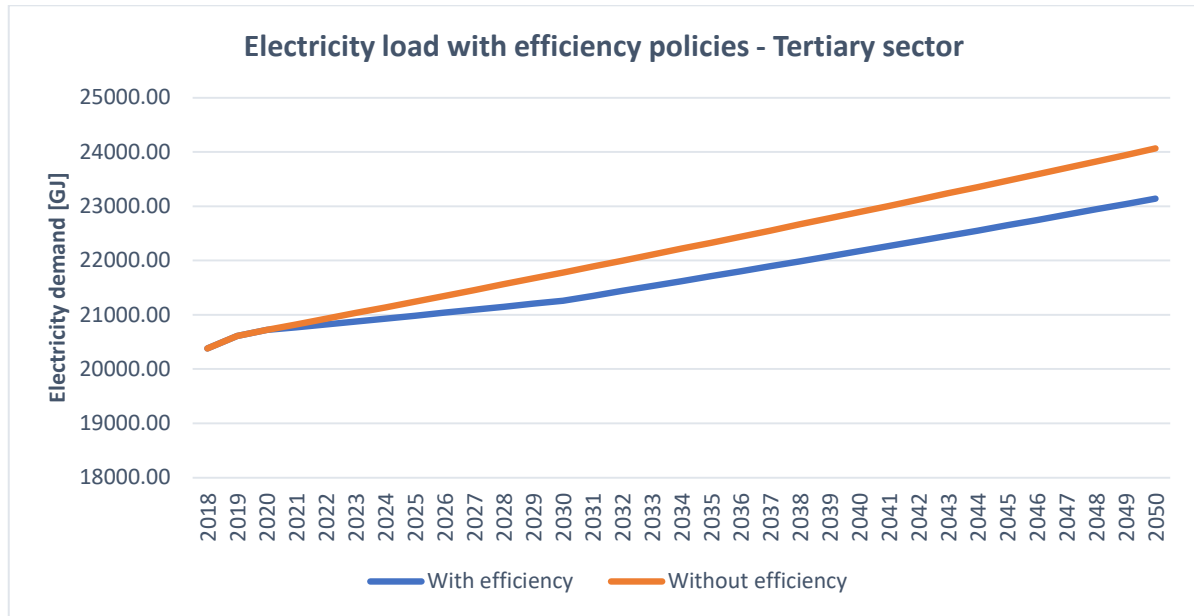

Figure 75. Tertiary sector electricity load with and without efficiency policies

9.4.4. Electric vehicles deployment

To define the electric vehicles deployment scenario, it is assumed that the entire new fleet is used by residential users only.

The total number of EVs in the island is then quantified with respect to the total fleet in Procida in 2018, whose information is provided by (ACI, 2019), by imposing some targets for the penetration share at specific years (namely 2025, 2030, 2040, 2050).

To define the deployment scenario, additional assumptions should be made, in particular:

- the share of recharging vehicles at peak hours
- the state of charge at depart
- the number of recharges per day
- the share of EVs used per day

The evaluation of the electricity load is then estimated based on the methodology presented in section 9.3.2.5.

9.4.5. V1G scenario

The V1G is a technique that allows to better manage the EVs load. This method can be used by TSOs or DSOs to shift a part of the electricity load due to electric vehicles from peak hours to off-peak ones.

For the purposes of the modelling, this is made by modifying the amount of electricity demand at peak and off-peak hours (and thus at the different time-slices). To do this, a new parameter should be included in the calculation, that is the share of EVs participating to the V1G, SH_{V1G} . The total electricity demand remains constant instead.

Assuming only one charge per vehicle and per day, the new daily electricity demand in peak hours, $E'_{EV,peak,d}$, is estimated as:

$$E'_{EV,peak,d} = E_{EV,d} \cdot SH_{peak} - E_{EV,peak,d} \cdot SH_{V1G}$$



The one at off-peak hours, $E'_{EV,offpeak,d}$, is instead equal to:

$$E'_{EV,offpeak,d} = (1 - SH_{peak}) \cdot E_{EV,d} + E_{EV,peak,d} \cdot SH_{V1G}$$

The annual electricity consumption at peak and off-peak hours can then be estimated as:

$$E'_{EV,peak} = E'_{EV,peak,d} \cdot 365$$

$$E'_{EV,offpeak} = E'_{EV,offpeak,d} \cdot 365$$

To allocate the annual electricity consumption at different time-slices, an additional hypothesis should be made concerning the distribution of the “shifted load” in the off-peak time-slices.

In the case of this model, it is assumed that all the electricity is shifted from the evening (EVE) to the night (NGT).

9.5. OTHER CONSTRAINTS DEFINITION

9.5.1. Max photovoltaics capacity constraints

A constraint on the max capacity of PVs in the island is defined in the model. As the photovoltaics installations are separately defined for the residential, tertiary and public sector, the estimation of the max amount of installable capacity must be independently defined for the three PV types as well.

The methodology applied to estimate the maximum amount of photovoltaics’ capacity for each sector is explained in the following.

9.5.1.1. Residential PV installations

For the residential sector, it is assumed that the PV technology can only be installed on roofs to ease the calculation (but in reality it is not the case in Procida).

Starting from this hypothesis, the max potential for PVs capacities is evaluated by means of *PVWatts Calculator*²⁹, a tool developed by NREL.

It is observed that in Procida there are different sizes of the buildings, according to the zone. Due to this, an assumption on the average roofs dimension is made. In particular, the buildings are divided into small and large ones, and an average roof dimension is defined for each of them based on observations.

For the first ones, the average dimension is assumed to be 20 m², that according to the NREL tool corresponds to a PV power rate of about 3.0 kWp. For the second ones the value is set to 105 m², that is equivalent to a system capacity of about 16 kWp. **Figure 76** shows an example of roof capacity estimation with *PVWatts Calculator*.

²⁹ <https://pvwatts.nrel.gov/pvwatts.php>



Figure 76. Example of roof surface estimation with PVWatts Calculator tool

Assuming that the buildings are equally divided into large and small ones, the average max capacity for a residential building in Procida, $C_{max,building}$, is estimated:

$$C_{max,building} = \frac{C_{max,large} + C_{max,small}}{2} = \frac{16 + 3}{2} = 9.5 \text{ kW/building}$$

Where $C_{max,large}$ and $C_{max,small}$ are the equivalent capacity for large and small buildings respectively.

In the practice, this approach is equivalent to assume an average roof dimension of 65.2 m².

Considering the total number of residential buildings provided by ISTAT, n_{RES} , the max installable capacity on residential roofs, $C_{max,RES}$, can be estimated:

$$C_{max,RES} = C_{max,building} \cdot n_{RES} = 9.5 \cdot 2807 = 19826.5 \text{ kW} \approx 19.83 \text{ MW}$$

However, as it is not realistic that all the roofs are covered by PVs, it is assumed that at most only 2/3 of the roof are used for PVs:

$$C'_{max,RES} = C_{max,RES} \cdot \frac{2}{3} = 19826.5 \text{ kW} \cdot \frac{2}{3} = 13217.7 \text{ kW} \approx \mathbf{13.22 \text{ MW}}$$

This value is compared to the one obtained with a gross estimation of the capacity potential can be made knowing that in Italy the average capacity for residential users is 4.8 kWp (GSE, 2019):

$$C'_{max,RES} = 4.8 \cdot 2807 = 13473.6 \text{ kW} \approx 13.47 \text{ MW}$$

The two values being quite close, the estimation is assumed to be quite significative.

9.5.1.2. Public PV installations

PVWatts Calculator is also used to estimate the total installable capacity on public buildings' roofs. In this case, the estimation is made by summing up the installable capacity of the buildings whose address is known.

The maximum amount of installable capacity is estimated as:

$$C'_{max,PUB} = 432 \text{ kW} \cdot \frac{2}{3} = 288 \text{ kW} \approx \mathbf{0.29 \text{ MW}}$$



9.5.1.3. Tertiary PV installations

For the estimation of the tertiary maximum PV capacity care should be taken for the definition of the buildings' roofs on which to install the PV systems. Indeed, it is observed that in Procida several tertiary buildings (and in particular several shops and restaurants) are integrated in residential ones.

The estimation of the total number of buildings on which it is possible to install PV systems is based on the data provided by ISTAT concerning the type of enterprises that were present in Procida in 2017. Starting from this data, a classification is made between the shops that are considered as integrated in residential buildings and the ones that are self-contained.

The list of enterprises comprises industrial and tertiary ones. Due to this reason, a first classification is made to distinguish the first from the second. Then, for both the sectors a classification is made to distinguish the businesses that are considered as integrated in residential buildings and self-contained ones. At the end, on 577 businesses present on the territory, only 87 are assumed not to be integrated in other buildings. A summary is shown in **Table 20**.

Table 20. Summary of the enterprises in Procida classified by building type

Businesses in Procida by estimated building type	
Businesses integrated in residential buildings	490
Self-contained buildings - tertiary	78
Self-contained buildings - industry	9
TOTAL	577

As the aim of the evaluation is to estimate the installable capacity on tertiary buildings, the industrial ones are excluded from the analysis.

For the 78 tertiary buildings available for PV installations, the max capacity is estimated based on assumptions on the available surface. It is assumed an average surface of 50 m² for businesses belonging to the *wholesale and retail, motor vehicle and motorcycle repair and professional, scientific and technical activities* category, and 100 m² for the *transport and storage and accommodation and food services* category. The equivalent installable capacity per type of building is then estimated with *PVWatts Calculator*. At the end, a final value of 1050 kW is obtained for the tertiary sector.

The summary of the assumptions for the total installable PV capacity is shown in **Table 21**.

Table 21. Summary of the values used for the estimation of the total installable PV capacity in the tertiary sector

Type of business	Nb of buildings	Assumed average surface [m2]	Equivalent installable capacity per building [kW/building]	Total installable capacity [kW]
Wholesale and retail, motor vehicle and motorcycle repair	15	50	7.5	112.5
Transport and storage	22	100	15	330
Accommodation and food services	40	100	15	600



Professional, scientific and technical activities	1	50	7.5	7.5
Total				1050 kW

9.5.2. Max batteries capacity constraint

Another constraint is set for the maximum capacity of the batteries, that is separately defined for each of the sectors of application. For the residential, tertiary and public sector the maximum capacity is defined as it follows:

$$C_{max,BAT,s} = \overline{C_{BAT,s}} \cdot N_{B,s}$$

Where $\overline{C_{BAT,s}}$ is an average capacity size of a battery used in the specific sector s , $N_{B,s}$ the total number of buildings of the considered sector s in the island.

The summary of the values used for $\overline{C_{BAT,s}}$ and $N_{B,s}$ for each sector are summarised in **Table 22**.

Application (s)	$\overline{C_{BAT,s}}$ [kWh]	$N_{B,s}$ [-]	$C_{max,BAT,s}$ [kWh]
Residential	25	2807	70175
Tertiary	50	~80	4000
Public	50	20	1000

Table 22. Summary of the values used to define the max batteries capacity constraint

9.5.3. Constraint on new batteries investments

An additional constraint is imposed on the maximum amount of new batteries investments at each year of the horizon. The values used for this constraint, specified for each sector of application and kept constant for all the years, are summarized in **Table 23**.

Table 23. Summary of the values used as maximum amount of new investments on batteries

Application	Max capacity increase [GJ/year]
Residential	40
Tertiary	3
Public	1

9.5.4. Smart Energy Hub investments

A constraint is also imposed on the Smart Energy Hub investments. Indeed, as according to the project planning this device will be installed in June 2021, the installation of the Smart Energy Hub is forced at 2022. No constraints are set for later years instead.



10. ANNEX II: TIMES-HINNOYA

The information in this annex are excerpts from the TIMES-Hinnøya model documentation.

10.1. BASE YEAR ENERGY SYSTEM

10.1.1. Demand side – Load profiles

Based on measured data, the monthly average diurnal electricity demand in southern part of Norway for residential, primary (agriculture and forestry, fishing, and fish farming), secondary (industry and mining), and Tertiary (service) sectors were found in (Ericson and Halvorsen, 2008). Assuming that the consumption pattern would be similar in the Northern part as well, the normalized hourly aggregate diurnal electricity consumption profile for the aforementioned energy sectors in Hinnøya were used as well. The normalization is the share of each timeslice in total annual production or consumption. That is hour x value divided by total annual x consumption keeping in mind that the model includes 576 timeslices which are not continuous in TIMES. The aggregate annual electric energy consumption in 2015 is provided in Table 4, and the normalized load profile for each sector is also provided in Figure 3-Figure 10.

Table 4: Electricity demand in residential and industry sectors in 2015 (TJ).

Region	Residential	Primary	Secondary	Tertiary
Harstad	797	58	103	481
Rest Hinnøya	522	76	77	263
Grytøya	16.92	6.85	3.24	0

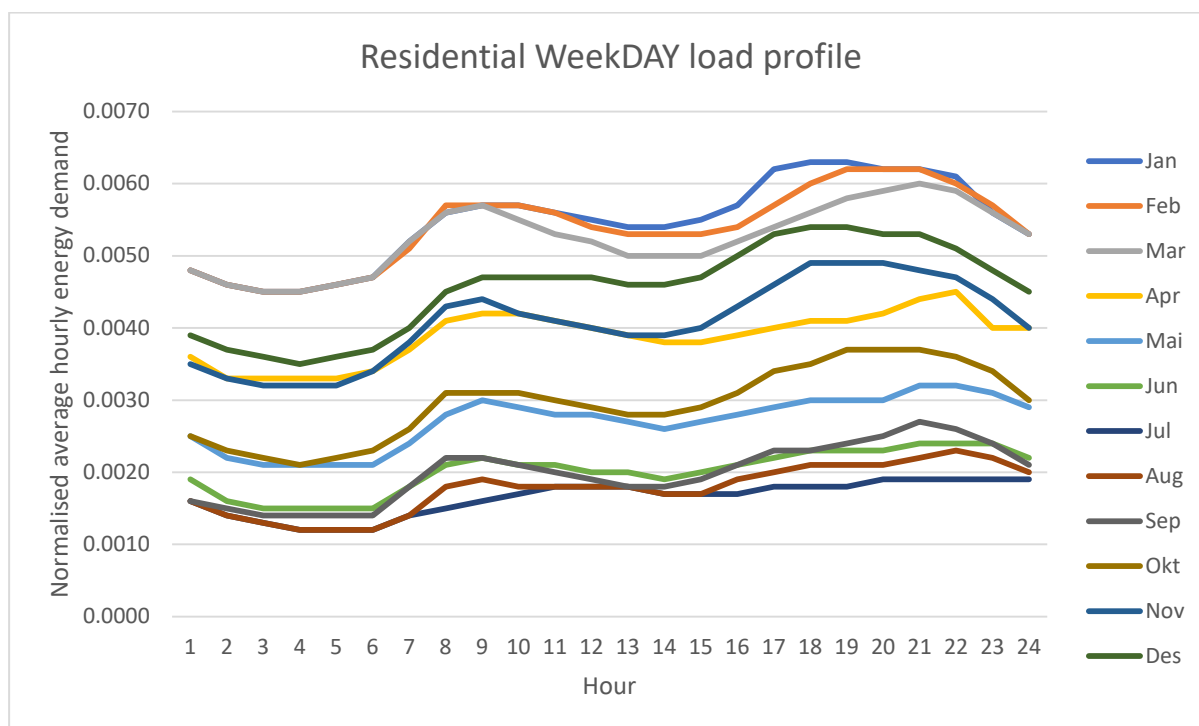

Figure 3: The normalized monthly average diurnal electricity demand profile of the residential sector in a weekday

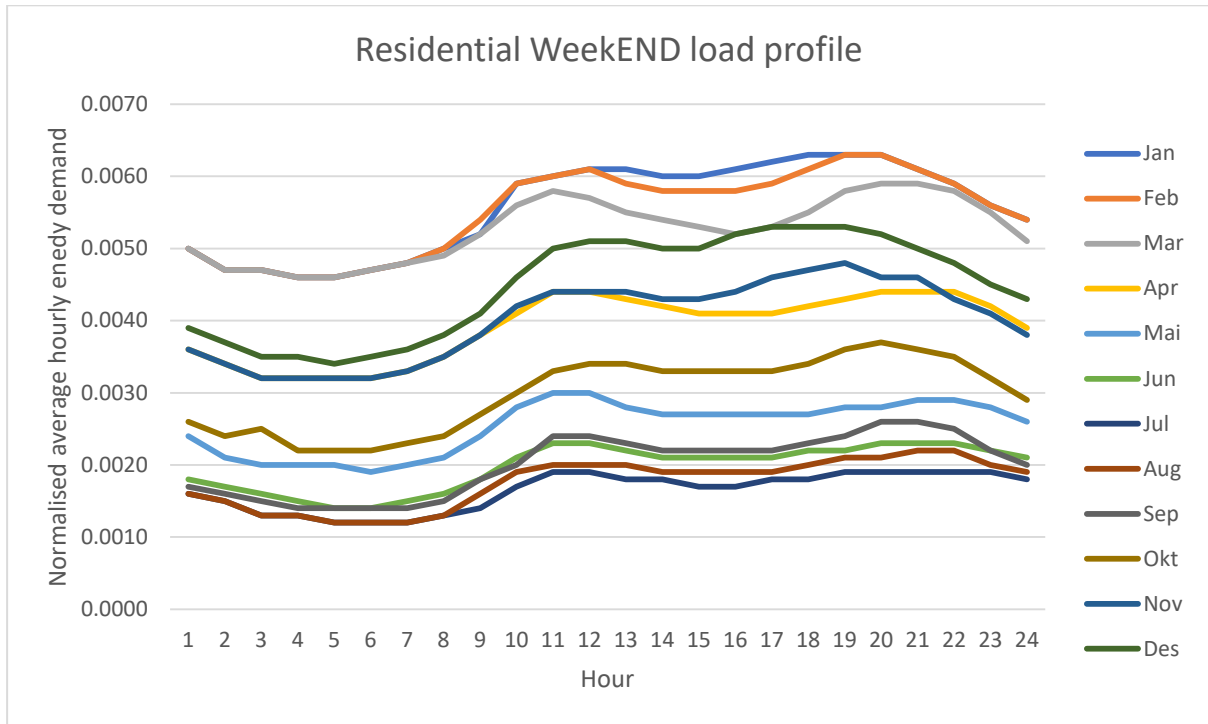

Figure 4: The normalized monthly average diurnal electricity demand profile of the residential sector in a weekend.

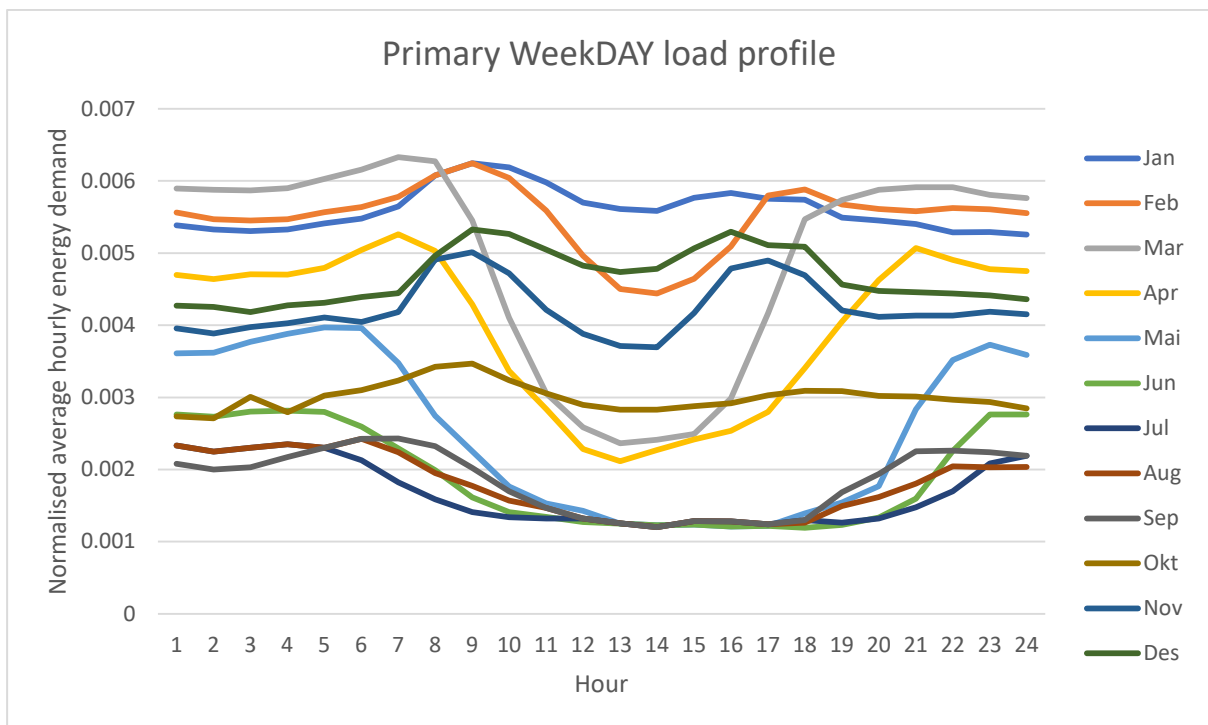

Figure 5: The normalized monthly average diurnal electricity demand profile of the primary sector (agriculture and forestry, fishing, and fish farming) in a weekday.

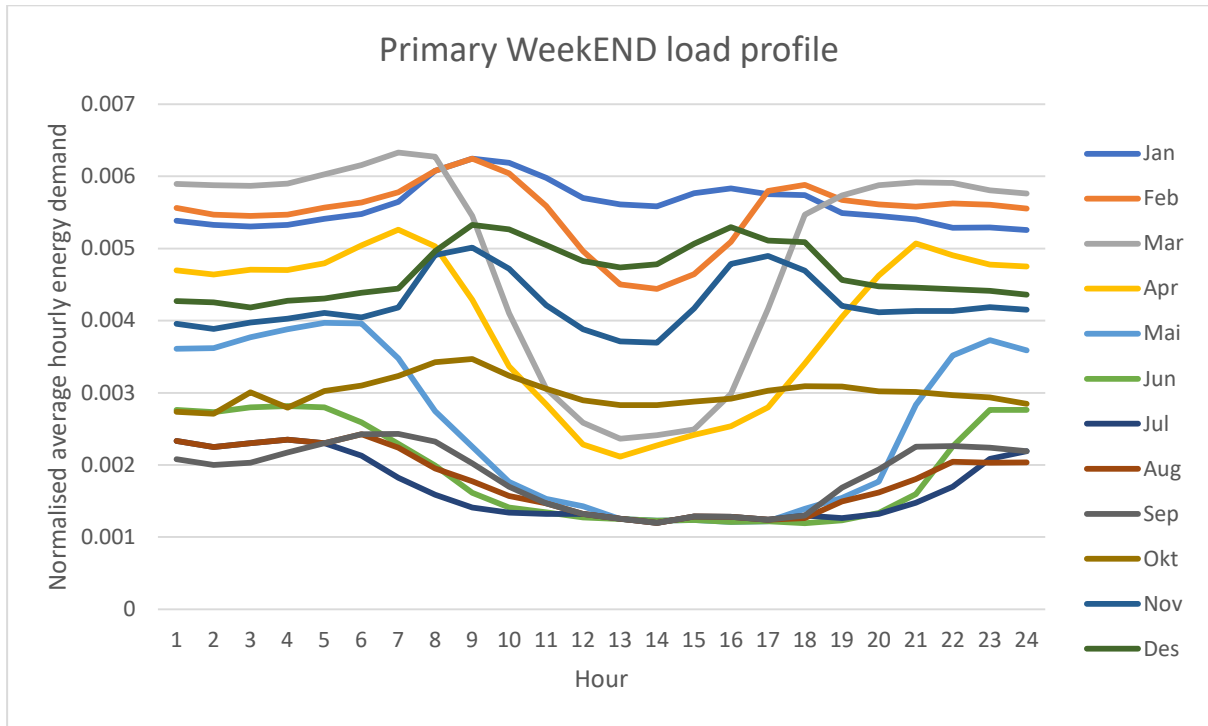

Figure 6: The normalized monthly average diurnal electricity demand profile of the primary sector (agriculture and forestry, fishing, and fish farming) in a weekend.

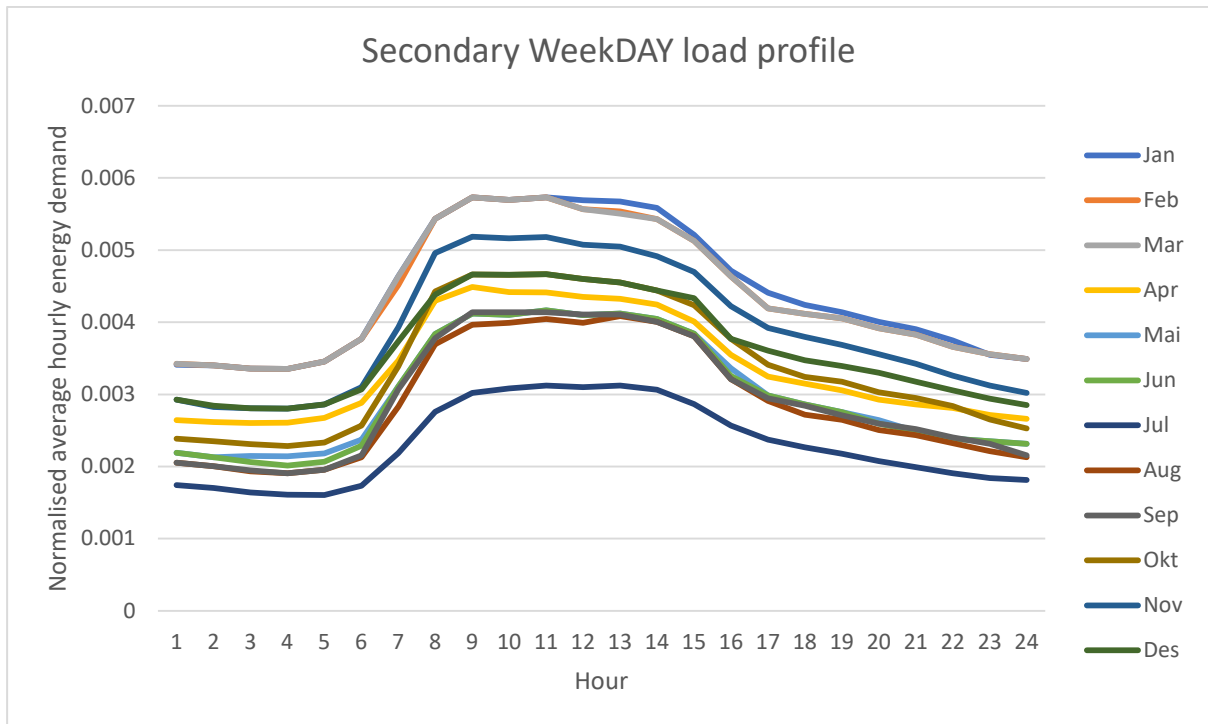

Figure 7: The normalized monthly average diurnal electricity demand profile of the secondary sector (industry and mining) in a weekday.

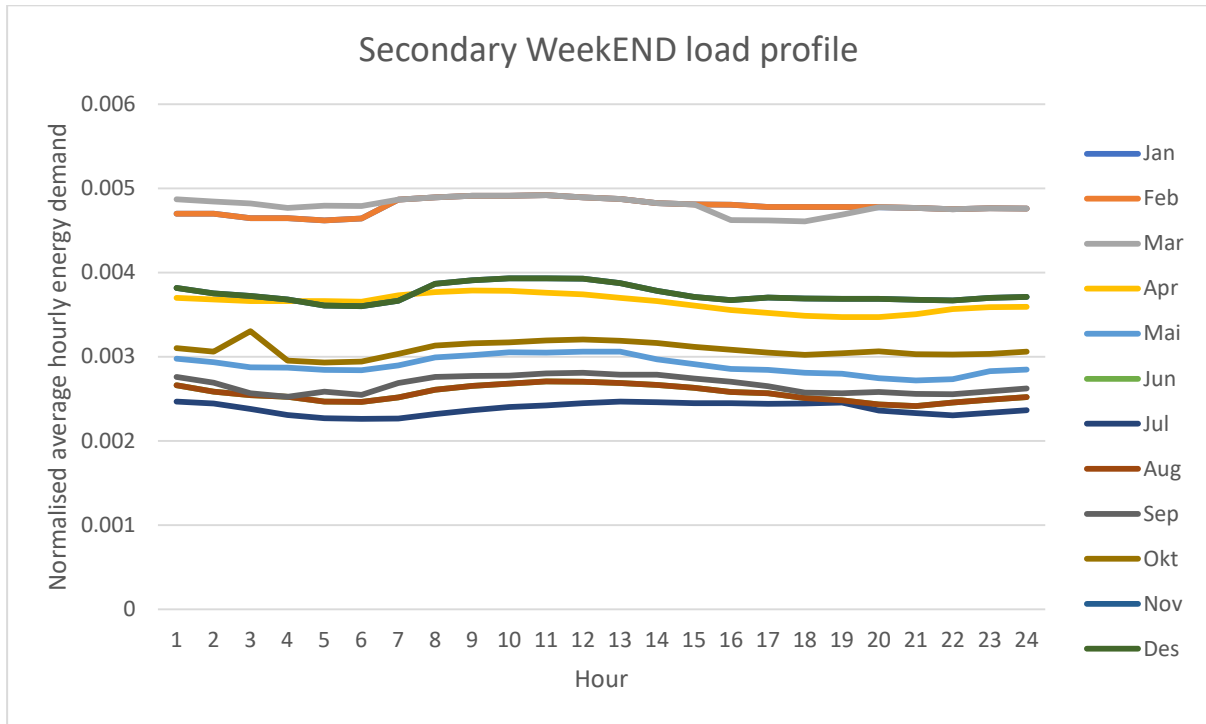

Figure 8: The normalized monthly average diurnal electricity demand profile of the secondary sector (industry and mining) in a weekend.

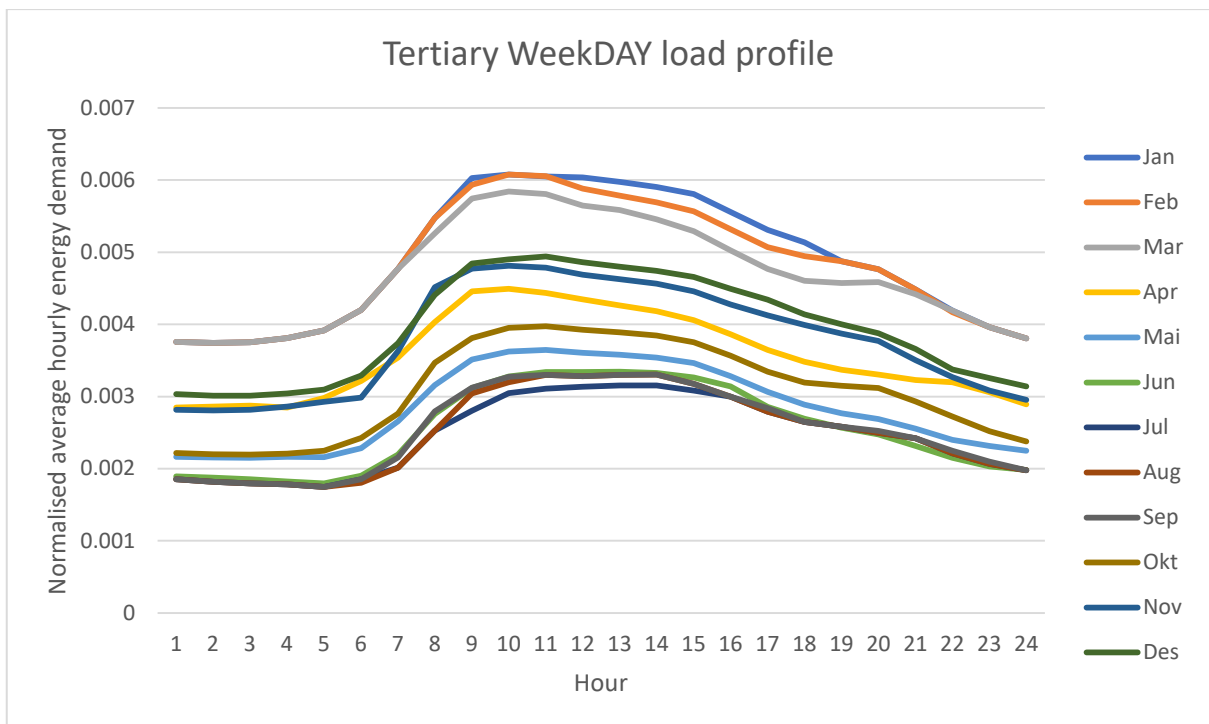

Figure 9: The normalized monthly average diurnal electricity demand profile of the tertiary sector (service) in a weekday.

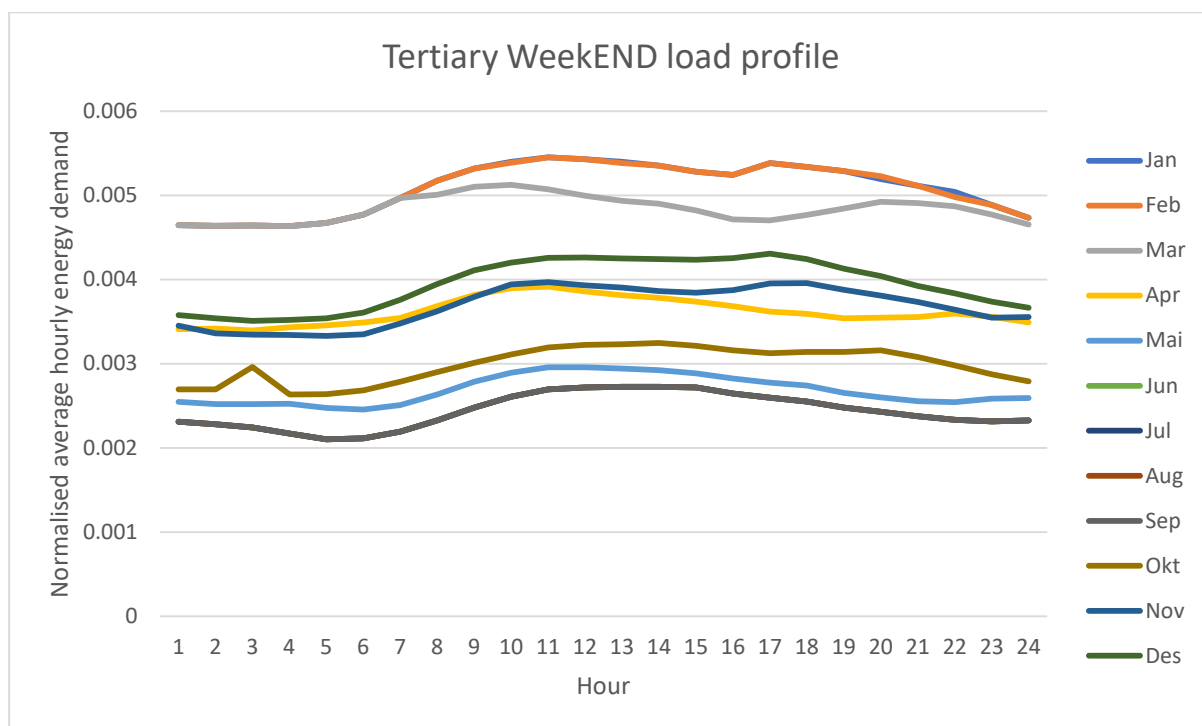

Figure 10: The normalized monthly average diurnal electricity demand profile of the tertiary sector (service) in a weekend.

10.2. ENERGY SYSTEM EVOLUTION

10.2.1. New technologies

10.2.1.1. Renewable energy technology

The technical parameters of both technologies (wind and hydro) are summarized in the below table and based on (Danish Energy Agency, 2018a; NVE, 2019b)

Table 24 – Technical parameters of VREs technologies used in TIMES-Hinnøya

Technology	Efficiency/Capacity factor (%)	Investment cost (M€/MW)			Fixed O&M cost (1000€/MW/year)	Variable cost (€/MWh)	Technical life time (year)
	2020/2030/2050	2020	2030	2050	2020/2030/2050	2020/2030/2050	
Onshore wind turbine	32	1.07	1	0.91	14/12.6/11.34	1.5/1.35/1.22	30
Offshore wind turbine (near-shore)	43	1.48	1.41	1.34	36/34.25/32.54	2.67/2.67/2.3	30



Run of river hydro	47-53	1.25	1.25	1.25	-	6.84	40
--------------------	-------	------	------	------	---	------	----

10.2.1.2. Transport technologies

The market share of new registered cars by car size is shown in Table 10. Based on their curb weight and European market segmentation, in the model, the market share of new cars is constrained as small (<1.3 ton), medium (1.3-1.8ton) and large (>1.8 ton) with the average market share in between 2009 and 2011 as shown in Table 7 with a 10-15% relaxation factor towards 2050.

Table 10: Market share of new cars by car size in Norway in 2012.

Size	2011	2010	2009	2008	2007	2006	2005
Small (<1.3ton)	31.40 %	31.66 %	29.82 %	29.82 %	33.51 %	35.36 %	31.40 %
Medium (1.3-1.8ton)	65.96 %	65.70 %	68.07 %	67.81 %	63.85 %	57.78 %	65.96 %
Large(>1.8ton)	2.64 %	2.64 %	2.11 %	2.37 %	2.64 %	6.86 %	2.64 %

Table 11: Relative fuel economy of small and large cars compared to a medium car in Norway.

Fuel	Size	Type approved emission (g/km)	Normalised fuel economy compared to medium car.
Diesel	Small (<1.3ton)	108	0.76
	Medium (1.3-1.8ton)	143	1
	Large(>1.8ton)	200	1.39
Petrol	Small (<1.3ton)	130	0.76
	Medium (1.3-1.8ton)	171	1
	Large(>1.8ton)	235	1.37

The annual traffic volume for new cars is assumed to be the average value between 2015 and 2018 in each region. Thus 12000 km in Harstad and 11000 km in Rest Hinnøya is assumed for all types of cars irrespective of technology. Fuel economy of cars for short, medium, and long driving is adjusted based on type approved data shown in Table 11. Segment A/B are dedicated for mini and small cars, C/D for the medium and large ones and finally J for sport utility cars including off-road vehicles according to the European car classification (EAFO, 2019).

Table 12: Techno-economic data of passenger cars by segment in 2019 price level [18-21].

Vehicle type	Vehicle segment	Fuel economy-mixed driving (MJ/km)	Investment cost including VAT (€)			Maintenance & operation cost (€/km)		
		2020/2030/2050	2020	2030	2050	2020	2030	2050
ICE-gasoline	A/B	1.6/1.14/1.14	23539	23123	22498	0,016	0,017	0,016
	C/D	2.11/1.5/1.5	47019	46360	45042	0,027	0,030	0,028
	J	2.89/2.05/2.05	55905	55513	54728	0,037	0,039	0,038
ICE-diesel	A/B	1.24/0.89/0.89	24207	23993	23565	0,017	0,017	0,016
	C/D	1.63/1.18/1.18	47125	46479	45618	0,032	0,031	0,030
	J	2.26/1.64/1.64	56646	55877	55109	0,042	0,041	0,040
HFCV	A/B	0.57/0.41/0.41	64618	51695	46202	0,031	0,014	0,013
	C/D	0.75/0.54/0.54	92291	76760	70786	0,025	0,023	0,022
	J	1.03/0.74/0.74	105404	88605	82372	0,016	0,029	0,028
BEV	A/B	0.39/0.29/0.29	23771	21379	18848	0,013	0,012	0,012
	C/D	0.52/0.38/0.38	40437	36799	32882	0,021	0,020	0,019
	J	0.71/0.52/0.52	50138	45613	39866	0,030	0,029	0,037
PHEV20s-	A/B	0.87/0.58/0.58	35121	32732	30582	0,016	0,016	0,016



gasoline	C/D	1.15/0.77/0.77	45358	42312	39773	0,027	0,027	0,027
	J	1.58/1.05/1.05	56030	52547	49367	0,037	0,037	0,037
Hybrid-gasoline	A/B	1.08/0.71/0.71	25422	24972	24297	0,016	0,017	0,016
	C/D	1.42/0.93/0.93	58304	57487	55852	0,027	0,030	0,028
	J	1.94/1.27/1.27	63731	63284	62390	0,037	0,039	0,038
Hybrid-diesel	A/B	0.97/0.66/0.66	26144	25912	25450	0,017	0,017	0,016
	C/D	1.28/0.87/0.87	58435	57634	56567	0,032	0,031	0,030
	J	1.78/1.21/1.21	64576	63700	62825	0,042	0,041	0,040

Table 13: Techno-economic data of light- and heavy duty vehicles by segment in 2015 price level [18, 19, 22]

Vehicle type	Vehicle segment	Fuel economy- Average (MJ/km)	Investment cost (1000€)			Maintenance & operation cost (€/km)	Referenc e
		2020/2030/2050	2020	2030	2050	2020/2030/2050	
ICE-Diesel	Van (1-3.5 ton)	3.35	25.7	25.7	25.7	0.46	[23, 24]
	City bus (12m)	15	197	197	197	0.18	
	Light duty truck (<12 ton)	8	96.5	96.50	96.5	0.41	
	Heavy duty truck (>12 ton)	11	123	123	123	0.52	
BEV	Van (1-3.5 ton)	1	54	49	43	0.17	
	City bus (12m)	8.28/7.2	442	403	352	0.2/0.15	
	Light duty truck (<12 ton)	2.4	207	189	165	0.18	
	Heavy duty truck (>12 ton)	3.24	246	225	196	0.19	
HFCV	Van (1-3.5 ton)	1.7	90	76	71	0.16	
	City bus (12m)	12	786	660	614	0.3/0.2	
	Light duty truck (<12 ton)	4.2	338	284	264	0.16	
	Heavy duty truck (>12 ton)	5.64	394	331	307	0.21	

Note: In the model, the fuel economies provided in Table A2 might be adjusted to fit the reference energy system fuel consumption in 2010. After 2020, based on [25], overall efficiency of ICES assumed to increase by 37% and 41% for diesel and gasoline engines in all vehicle segments. In the absence of suitable data, the cost ratios between conventional and ETTs in passenger car segment were applied in van, buss, and trucks segments whenever required.

10.2.1.3. Storage

Technical parameters of Li-Ion battery system cost used in TIMES-Hinnøya model are found below.



Table 25 – Parameters of Li-Ion system cost used in the TIMES-Hinnøya model (Danish Energy Agency, 2018b; European Commission. Joint Research Centre., 2018)

Technology	Efficiency (%)	Investment cost (€/kWh)	Variable cost(€/MWh)	Technical life time (year)
	2020/2030/2050	2020/2030/2050	2020/2030/2050	2020/2030/2050
Li-ion storage battery system	95	1120/672/280	2/1.8/1.6	20/25/30

11. ANNEX III: TIMES MODELLING DETAILS

11.1. THE CONSTRAINTS OF TIMES MODEL

The detail of these that can be found in (R. Loulou et al., 2016).

11.1.1. Capacity transfer

The total capacity installed at time t for the process p must be equal to the capacities already installed before the start of the model period as well as the new capacities installed before the moment t whose lifetime has not ended. If we denote by P the set of processes and T the set of periods, then $\forall r \in R, \forall t \in T$ and $\forall p \in P, \forall r \in R, \forall t \in T$ et $\forall p \in P$,

$$CAP(r, t, p) = \sum_{t' < t} NCAP(r, t', p) \mathbb{1}_{t-t' < LIFE(r, t', p)} + RESID(r, t, p) ,$$

with:

- $RESID(r, t, p)$ = installed capabilities for p technology before the first model period and still running at t
- $LIFE(r, t', p)$ = lifetime of the technology p .

11.1.2. Link between activity and flow

It is a question of linking the flow of commodities consumed or produced by a process p at time t to the activity of the same process. If we note S all the time-slices, we have then $\forall r \in R, \forall t \in T, \forall p \in P$ et $\forall s \in S$,

$$ACT(r, t, p, s) = \sum_{c \in pcg} \frac{FLO(r, t, p, c, s)}{ACTFLO(r, p, c)} ,$$

with:

- pcg = primary commodity group i.e. all the amenities entering or leaving the process, necessary to define to which set is fixed the conversion factor.
- $ACTFLO(r, p, c)$ = conversion factor (often equal to 1) from the activity of the technology to the flow of a commodity c belonging to the pcg . This factor defines a kind of relative efficiency of the technology for each convenience.

11.1.3. Capacity utilization

The activity of a technology cannot be higher than what can be produced by the installed capacity, in which case it is defined $\forall r \in R, \forall t \in T, \forall p \in P$ et $\forall s \in S$,



$$ACT(r, t, p, s) \leq AF(r, t, p, s) PRC_CAPACT(r, p) FR(r, s) CAP(r, t, p)$$

with:

- $AF(r, t, p, s)$ = process availability factor p at period t and time-slice s
- $PRC_CAPACT(r, p)$ = conversion factor between the units defined for process capacity and activity. Thus, for an activity in PJ and a capacity in GW, we will have $PRC_CAPACT(r, p) = 31.536$ over one year
- $FR(r, s)$ = fraction of the duration of the time-slice over a year. So if the time-slice represents a season, then $FR(r, s) = 0.25$

11.1.4. Production/consumption balance

Production in a region and its imports for a given commodity must be in balance with the quantity consumed and exported. In the case of energy carriers, an inequality constraint is used to allow a surplus of production. If we denote C all the amenities, then we have $\forall r \in R, \forall t \in T, \forall c \in C$ et $\forall s \in S$,

$$\left[\begin{aligned} & \sum_{\substack{p \in P \\ c \in TOP(r,p,c,out)}} (\mathbf{FLO}(r, t, p, c, s) + \mathbf{SOUT}(r, t, p, c, s) STG_EFF(r, p)) \\ & + \sum_{\substack{p \in P \\ c \in RPC_IRE(r,p,c,imp)}} \mathbf{IRE}(r, t, p, c, s, imp) + \sum_{p \in P} Release(r, t, p, c) \mathbf{NCAP}(r, t, p, c) \\ & * COM_IE(r, t, c, s) \\ & \geq \sum_{\substack{p \in P \\ c \in TOP(r,p,c,in)}} (\mathbf{FLO}(r, t, p, c, s) + \mathbf{SIN}(r, t, p, c, s)) \\ & + \sum_{\substack{p \in P \\ c \in RPC_IRE(r,p,c,exp)}} \mathbf{IRE}(r, t, p, c, s, exp) \\ & + \sum_{p \in P} Sink(r, t, p, c) \mathbf{NCAP}(r, t, p, c) + FR(r, c, s) \mathbf{DEM}(c, t) \end{aligned} \right]$$

with :

- $TOP(r, p, c, out/in)$ = all the commodities entering or leaving the process p
- STG_EFF = efficiency of storage technology p
- $RPC_IRE(r, p, c, imp/exp)$ = all imported or exported commodities bring the process to life p
- $COM_IE(r, t, c, s)$ = efficiency of infrastructure for the transmission of commodity c , the transport network for example for electricity
- $Release(r, t, p, c)$ = amount of commodity c recovered per unit of process capacity p dismantled
- $Sink(r, t, p, c)$ = amount of commodity c required per unit of new process capacity p (useful to represent the consumption of materials or energy for the construction of a unit).

11.1.5. Relationship between flows

A process is defined by the flows of commodities entering and leaving it, so it is necessary to establish a relationship between these two quantities to be able to link them through the process. We then define the relationship constraint between the flows specifying that the ratio of the sum of the flows of commodities of the same type (energy carriers, emissions...) inputs on the sum of the outputs must be equal to a



constant (in the case of a single input commodity and a single output, this defines the efficiency of the process. So, $\forall r \in R, \forall t \in T, \forall c \in C$ et $\forall s \in S$,

$$\sum_{c \in cg_2} \mathbf{FLO}(r, t, p, c, s) = \mathbf{FLO_FUNC}(r, cg_1, cg_2) * \sum_{c \in cg_1} \mathbf{COEFF}(r, p, cg_1, c, cg_2, s) \mathbf{FLO}(r, t, p, c, s) ,$$

with:

- cg_1/cg_2 = all the commodities entering or leaving the process
- $\mathbf{FLO_FUNC}(r, cg_1, cg_2)$ = efficiency of the technology in relation to the sum of the group's commodities cg_1
- $\mathbf{COEFF}(r, p, cg_1, c, cg_2, s)$ = process efficiency in relation to commodities c and taking into account the coherence of flows between different time-slices.

11.1.6. Limit values of flows

The previous constraint offers great flexibility in the values of incoming and outgoing commodity flows in cases where cg_1 and cg_2 contain more than one element. A flow value limit constraint in flexible processes limits this flexibility by constraining the value of a flow entering or leaving a technology. For example, for a technology whose output consists of different commodities, each of them can be required to represent a limited part of the total process output. We define the constraint $\forall r \in R, \forall t \in T, \forall p \in P$ et $\forall s \in S$ par

$$\mathbf{FLO}(c) \{ \leq, \geq \} \mathbf{FLO_SHAR}(c) \sum_{c' \in cg} \mathbf{FLO}(c') ,$$

with:

- cg = a group of commodities entering or leaving the technology
- $\mathbf{FLO_SHAR}(c)$ = coefficient imposing a lower or upper bound on the share of commodity c in the mix of commodities entering or leaving the process p .

11.1.7. Operational reserve

For technologies with different levels of production or consumption according to time-slices, the installed capacity of technologies producing a commodity c at each period t and in each region r must be higher than the average demand, i.e. the average power demand during the timeslice when the peak of high demand occurs. It is a question of oversizing the system in order to deal with any unforeseen production problems. Thus $\forall r \in R, \forall t \in T$ et $\forall c \in C$

$$\begin{aligned} & \sum_{c \in P|_{c \in pcg(p)}} (\mathbf{PRC_CAPACT}(r, p) \mathbf{Peak}(r, p, c, s) \mathbf{FR}(s) \mathbf{CAP}(r, t, p) \mathbf{ACTFLO}(r, p, c)) + \\ & \quad \mathbf{IRE}(r, t, p, c, s, imp) + \\ & \quad \sum_{c \in P|_{c \notin pcg(p)}} \mathbf{NCAP_PKCNT}(r, p, c, s) \mathbf{FLO}(r, t, p, c, s) \geq \\ & (1 + \mathbf{COM_PKRSV}(r, t, c, s)) \sum_{p \in P(c)} (\mathbf{FLO}(r, t, p, c, s) + \mathbf{IRE}(r, t, p, c, s, exp)) , \end{aligned}$$

with:

- $P|_{c \in pcg(p)}$ = all processes producing commodity c with $c \in pcg$
- $P|_{c \notin pcg(p)}$ = all processes producing commodity c with $c \notin pcg$
- $P(c)$ = all processes consuming commodity c
- $\mathbf{NCAP_PKCNT}$ = fraction of the capacity of the process p available during the peak period, which makes it possible to differentiate the participation in the reserve of the different processes. Thus, for electricity, this coefficient is close to 1 for hydroelectric, nuclear or gas power plants, and around 0.25 for intermittent renewable production.
- $\mathbf{COM_PKRSV}$ = peak reserve factor for commodity given c at time slice s .



11.1.1.8. Constraints on commodities

It is also possible to add a number of commodity constraints such as annual or cumulative bounds over several periods on quantities associated with commodities. It is therefore possible to impose emission limits, for example, from certain sectors or globally on the entire system (this can also be done through taxes or penalties for each unit produced or consumed). In addition, constraints can be defined to limit the share of a technology p in the total production of a commodity c . Thus, the commodity flow c into or out of the process p can be limited to a fraction of the total production of c .

11.1.1.9. User constraints

TIMES allows adding a wide variety of user constraints involving the decision variables of the model and thus allowing to better representing the specificities of the studied system. Thus, it is possible to add constraints limiting investments in a particular technology, imposing a percentage of renewable energy in the electricity production mix.

In addition, it is possible or even recommended to use growth constraints that constitute a particular case of user constraints and that make it possible to limit the growth or decrease in the capacity of a technology in order to avoid excessively large investments abruptly. Classically, such a constraint is written as follows

$$CAP(t + 1) \{ \leq, \geq \} (1 + GROWTH(p))^{M(t+1)-M(t)} CAP(t) + K ,$$

With:

- $GROWTH(p)$ = maximum annual growth allowed for the technology p
- $M(t + 1) - M(t)$ = number of years in the time interval between periods t et $t + 1$
- K = necessary in the case where the process has no initial installed capacity, the constraint preventing the installation of this technology in the absence of K .

The model also allows technologies to be withdrawn even before the end of their operating period through the constraint of premature withdrawal of capacity (see (R. Loulou et al., 2016)).

11.2. RESOLUTION OF THE MATHEMATICAL PROGRAM

The mathematical program solved in TIMES is part of the family of linear integer programs (MILP). We propose here to first expose the theory of linear programming, and then to explain the main algorithms used by commercial solvers to solve these problems in whole numbers.

11.2.1. The notion of duality

Consider the following optimization problem,

$$\begin{cases} \min_{x \in \mathbb{R}^n} f(x) \\ f_i(x) \leq 0 \quad i=1, \dots, m \\ h_i(x) = 0 \quad i=1, \dots, p \end{cases}$$

We assume that his domain $\mathcal{D} = \bigcap_{i=1}^m \text{dom } f_i \cap \bigcap_{i=1}^p \text{dom } h_i$ is not empty and we note f^* the optimal value.

The underlying idea in duality theory is to take constraints into consideration by increasing the objective function with a weighted sum of these constraints.

Thus Lagrangian is defined as $L: \mathbb{R}^n \times \mathbb{R}^m \times \mathbb{R}^p \rightarrow \mathbb{R}$ by

$$L(x, \lambda, v) = f(x) + \sum_{i=1}^m \lambda_i f_i(x) + \sum_{i=1}^p v_i h_i(x) ,$$

with $\text{dom } L = \mathcal{D} \times \mathbb{R}^m \times \mathbb{R}^p$. The Lagrange multipliers or dual variables will be called λ and v .

The Lagrange dual function is defined $g: \mathbb{R}^m \times \mathbb{R}^p \rightarrow \mathbb{R}$ as the minimum value of L on x , then for $\lambda \in \mathbb{R}^m$, $v \in \mathbb{R}^p$,



$$g(\lambda, \nu) = \inf_{x \in \mathcal{D}} L(x, \lambda, \nu).$$

Proposal

The dual function g gives a lower bound for the optimal value f^* , in other words for all $\lambda \geq 0$ and for all ν , we have $g(\lambda, \nu) \leq f^*$.

evidence. Suppose that \tilde{x} is a feasible solution for the problem. So we have,

$$\sum_{i=0}^m \lambda_i f_i(\tilde{x}) + \sum_{i=0}^p \nu_i h_i(\tilde{x}) \leq 0 .$$

This suggests that $L(\tilde{x}, \lambda, \nu) \leq f(\tilde{x})$ and therefore by definition $g(\lambda, \nu) \leq f(\tilde{x})$. Since this is true for any achievable point \tilde{x} , then this is true for the optimal solution, hence $g(\lambda, \nu) \leq f^*$.

Consider the following mathematical program,

$$\min\{c^T x : Ax = b, x \in \mathbb{R}_+^n\} ,$$

which is a linear program in standard form.

The Lagrangian is then defined as,

$$L(x, \lambda, \nu) = c^T x - \lambda x + \nu^T (Ax - b) = -b^T \nu + (c + A^T \nu - \lambda)^T x .$$

Thus the dual function g is,

$$g(\lambda, \nu) = \inf_x L(x, \lambda, \nu) = -b^T \nu + \inf_x (c + A^T \nu - \lambda)^T x ,$$

So,

$$g(\lambda, \nu) = \begin{cases} -b^T \nu & \text{si } A^T \nu - \lambda + c = 0 \\ -\infty & \text{sinon} \end{cases}$$

Thus the best lower bound that can be obtained by the dual function is given by,

$$\max_{\lambda \geq 0} g(\lambda, \nu) .$$

Rewritten differently, we have the problem,

$$\max_{\substack{A^T \nu + c \geq 0 \\ \nu \in \mathbb{R}^p}} -b^T \nu .$$

The above problem is called the dual (Lagrange) problem. The initial problem is then called primal. Thus the optimal value of the dual d^* is by definition the best lower bound for f^* i.e. $d^* \leq f^*$, this property is called the weak duality.

11.2.2. The simplex algorithm

Consider the following mathematical program,

$$(LP) \quad \max\{c^T x : Ax = b, x \in \mathbb{R}_+^n\} ,$$

With A a matrix $m \times n$, c a matrix $1 \times n$ et b a matrix $m \times 1$ with $m \leq n$.

We assume that $\text{rg } A = m$. Thus, if this assumption is rarely met in practical cases, matrix A can be reduced to a matrix of rank m .

It should be noted that all the feasible solutions $S = \{x \in \mathbb{R}_+^n : Ax = b\}$ forms a convex polyhedron.

The linear program will be considered feasible if S is not empty. In addition, a feasible program is said to be limited if the objective is limited to S .



A point x is an extreme point of the convex polyhedron S if there are not two points $y, z \in S$ different from x and a scalar $\lambda \in [0,1]$ tel que $x = \lambda y + (1 - \lambda)z$. In other words, x cannot be written as a strict convex combination of two points of S .

The two main methods for solving linear programs are the internal point methods (Roos et al., 2006) and the simplex method proposed in 1947 by Dantzig (Dantzig, 1998). While the first has better results in theory, the second has proved to be the most effective and widely used in practice. This is based on the following observations, the demonstrations of which are not given here and can be found in (Chvatal, 1983).

Another characterization of an extreme point is as follows: a point x is an extreme point of S if and only if the columns $\{a_j: x_j > 0\}$ of A are linearly independent. In other words, the vectors of $A = \{a_1, a_2, \dots, a_n\}$ with a_j the j^{th} column of A associated with the non-zero components of x form a set of linearly independent vectors.

In addition, a feasible and limited linear program has an optimal solution at an extreme point of the convex polyhedron S .

These two observations constitute the central theory on which the simplex algorithm is based.

Definition

A base of A is any submatrix A_B formed by m linearly independent columns.

Let $A_B = \{a_{B_1}, \dots, a_{B_m}\}$ with $B = \{B_1, \dots, B_m\}$ and let $N = \{1, \dots, n\} \setminus B$. The equation $Ax = b$ can be rewritten,

$$A_B x_B + A_N x_N = b ,$$

with $x = (x_B, x_N)$. Thus a solution to $Ax = b$ which is called a basic solution associated with A_B is the point $x = (x_B, x_N)$ such as,

$$\begin{aligned} x_B &= A_B^{-1} b , \\ x_N &= 0 . \end{aligned}$$

In addition to this, if $x_B \geq 0$, the basic solution is said to be feasible.

A basic solution that can be implemented in the system $Ax = b$ corresponds to an extreme point of the convex polyhedron. In addition, at any extreme point there is at least one achievable basis.

Thus, the simplex method iterates from one achievable base to another adjacent achievable base, geometrically it passes from one vertex of the polyhedron S to another neighbouring vertex allowing reducing the value of the objective function.

A detailed explanation of the simplex algorithm can be found in (Bertsimas and Tsitsiklis, 1997).

11.3. LINEAR PROGRAMMING IN INTEGER NUMBERS

Let's consider the following linear program in integer numbers,

$$(P) \quad J = \max\{c^T x + h^T y: (x, y) \in S\} ,$$

with $S = \{x \in \mathbb{R}_+^n, y \in \mathbb{Z}^p : Ax + Gy \leq b\}$.

11.3.1. Branch & Bound

The branch & bound method was introduced by (Land and Doig, 1960) and is generally part of a family of algorithms based on the same procedure that constitutes a list of all the feasible solutions to the problem also called "divide and conquer" (D&C) (Morrison et al., 2016).

Definition 1



It is said that $\{S^i: i = 1, \dots, k\}$ is a division of S if $\bigcup_{i=1}^k S^i = S$. In addition, a division is called a partition if $S^i \cap S^j = \emptyset$ for $i, j = 1, \dots, k, i \neq j$.

The "divide and conquer" Principle is essentially based on the following proposal.

Proposition 1

Let the problem,

$$(P^i) \quad J^i = \max\{c^T x + h^T y: (x, y) \in S^i\} ,$$

with $\{S^i\}_{i=1}^k$ a division of S . So $J = \max_{i=1, \dots, k} J^i$.

Thus, if optimization on S is too complex, then it may be more obvious to optimize on subsets. We therefore divide the set of feasible solutions to the problem recursively into a partition of subsets generating sub-problems that we solve in order to compare the solutions.

In an extreme way, these divisions can be seen as a complete enumeration of the elements of S . With the exception of small problems, this enumeration is not viable and such a division should be avoided. Thus, let's suppose that S is divided into subsets $\{S^1, \dots, S^k\}$, we then want to find a rule specifying that no further division of a subset S^i is necessary. We will then say that the enumeration tree is pruned at the node S^i .

Proposition 2

The enumeration tree can be pruned to the node corresponding to S^i if one of the following conditions is verified

- i. Infeasibility: $S^i = \emptyset$.
- ii. Optimality: an optimal solution is found for (P^i)
- iii. Domination: $J^i \leq J$

However, the problem (P^i) remains an integer problem; one would therefore like to be able to use Proposal 2 without having to solve it. It is therefore classic to use the linear relaxation of the problem that we will note (P_R^i) defined by,

$$(P_R^i) \quad J_R^i = \max\{c^T x + h^T y: (x, y) \in S_R^i\} .$$

Thus, since $S^i \subset S_R^i$, we have,

$$J_R^i \geq J^i .$$

This allows us to determine a new pruning rule.

Proposition 3

The enumeration tree can be pruned to the node corresponding to S^i if one of the following conditions is verified

- i. (P_R^i) does not admit a solution
- ii. An optimal solution (x_R^i, y_R^i) de (P_R^i) satisfy $y_R^i \in S^i$ i.e. y_R^i is integer
- iii. $J_R^i < \underline{J}$ with \underline{J} a lower bound of (P) i.e. the value of a workable solution to the problem.

A general presentation of how the branch & bound algorithm works is as follows. Either L a collection of linear problems of form $J^i = \max\{c^T x + h^T y: (x, y) \in S^i\}$.

Stage 1. Initialisation. $L = (P)$ i.e. the root of the tree is determined as the initial problem. We fix the lower limit $\underline{J} = -\infty$ and upper $\bar{J} = +\infty$.

Stage 2. Termination test. If $L = \{\emptyset\}$, then the solution (x, y) which led to $\underline{J} = c^T x + h^T y$ is optimal.



Stage 3. Problem selection and relaxation. Choose a problem $(P^i) \in L$ and remove it from the collection i.e. we update L such that $L = L \setminus (P^i)$. Resolve its continuous relaxation (P_R^i) .

- If the problem does not admit a solution, go to step 2
- Either J_R^{i*} the objective value for the optimal solution (x_R^i, y_R^i) , go to step 4.

Stage 4. Pruning. Two cases can be distinguished here,

- if $J_R^{i*} \leq \underline{J}$ go to step 2
- otherwise
 - o if $y_R^i \notin S^i$, go to step 5
 - o if $y_R^i \in S^i$, so we have a better lower bound of the problem, so we fix $\underline{J} = J_R^{i*}$. We then delete all the other sub-problems dominated, in other words, those whose solution is lower than the new lower bound. Go to step 2.

Stage 5. Connection. Either $\{S^{ij}\}_{j=1}^k$ a division of $\{S^i\}$. Add problems $(P^{ij})_{j=1}^k$ to L i.e. we update L in such a way $L = L \cup (P^{ij})_{j=1}^k$ and go to step 2.

The algorithm exposed in this way therefore leaves a number of choices for the user (Bertsimas and Tsitsiklis, 1997; Wolsey and Nemhauser, 1999). We propose here to present the main methods used, it is necessary to see (Morrison et al., 2016) for a more detailed list.

11.3.1.1. Connection

Since at each node we use a continuous relaxation of the problem, the connection, in other words the division of the set S^i is done by adding linear constraints. To do this, a classical method is to divide $S^i = S^{i1} \cup S^{i2}$ by selecting a variable $y_j^i \in S_R^i$ optimal solution of continuous relaxation such that $y_j^i \notin S$ i.e. y_j^i is a fractional solution of continuous relaxation, then

$$S^{i1} = S^i \cap \{y_j \leq \lfloor y_j^i \rfloor\}$$

$$S^{i2} = S^i \cap \{y_j \geq \lceil y_j^i \rceil\}$$

This method is called variable dichotomy (Wolsey and Nemhauser, 1999) and is practical since it allows to add simple constraints of lower or upper bounds on a variable.

11.3.1.2. Selection of nodes

We have seen that in step 3 of the algorithm that it is necessary to choose a sub-problem from the list L i.e. a node. There are different methods of node selection (Wolsey and Nemhauser, 1999) that can be classified into two groups: a priori rules that are determined in advance and adaptive rules by which node selection is made based on the active node (Wolsey and Nemhauser, 1999).

One of the most commonly used a priori methods is the depth-first search (plus backtracking): if the active node is not abandoned, the next node considered is one of its descendants. Thus, it is a question of sinking as deeply as possible into the tree. The following figure illustrates the exploration of a tree by this method by choosing the leftmost descendant each time and applying backtracking (when a node is abandoned, one goes up the tree until reaching a node from which a descendant has not been explored).

The opposite method is the breadth-first search method, which consists in exploring all the nodes of a level before looking at the nodes of the next level.

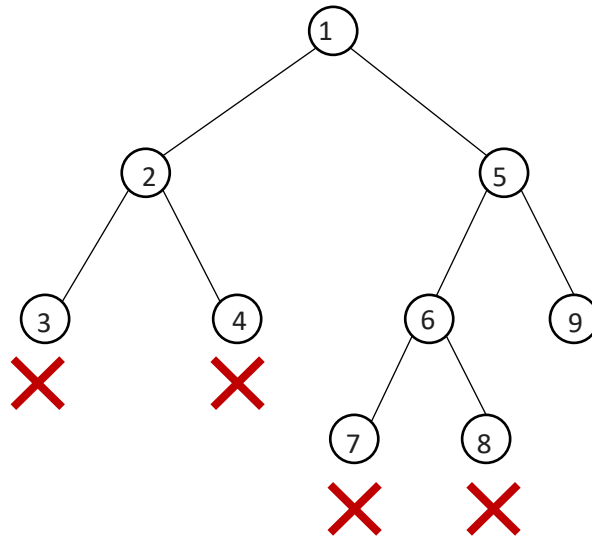

Figure 77. Depth-first search with backtracking

11.3.2. Cutting plane

The main idea in the secant plane method is to solve the problem (P) by solving a sequence of linear programs as follows: first of all, the continuous relaxation of the problem i.e. the problem (P_R) whose optimal solution is (x^*, y^*) is solved. If $y^* \in \mathbb{Z}^p$, then it is an optimal solution for (P) . Otherwise, we add to the problem an inequality constraint satisfied by any complete solution of the problem but violated by (x^*, y^*) . Thus, it is a question of obtaining a linear program with an increasingly narrow set of feasible solutions

A generic algorithm of the secant plane method is given as follows,

Stage 1. Initialisation. We consider the continuation of continuous relaxations of the problem $\{(P_R)^t\}_t$ and we note $S_R^0 = \{x \in \mathbb{R}_+^n, y \in \mathbb{R}^p, Ax + Gy \leq b\}$. We solve the program $(P_R)^0$ with (x^0, y^0) the optimal solution.

Stage 2. Refinement. We define the problem $(P_R)^t$ that we want to solve as $\max\{c^T x + h^T y : (x, y) \in S_R^t\}$ with $S_R^t = S_R^{t-1} \cap \{y \in \mathbb{R}^p : \pi^{t-1} y \leq \pi_0^{t-1}\}$ where (π^{t-1}, π_0^{t-1}) defines a valid inequality for S (or a valid cut) i.e. if (x^{t-1}, y^{t-1}) is an optimal solution for $(P_R)^{t-1}$, then $\pi^{t-1} y^{t-1} > \pi_0^{t-1}$.

Thus, the key element of the method is the choice of valid cuts. There are many possible cuts (Cornuéjols, 2007), the most famous being the Gomory cutting method introduced in 1958.

11.3.3. Branch & cut

In practice today, the most commonly used method is the branch & cut method, which combines the two methods seen above. Thus, it is a question of using cuts when solving sub-problems in the tree in order to improve the limits obtained by continuous relaxation (Padberg and Rinaldi, 1991).

12. REFERENCES

Akrami, A., Doostizadeh, M., Aminifar, F., 2019. Power system flexibility: an overview of emergence to evolution. J. Mod. Power Syst. Clean Energy 7, 987–1007. <https://doi.org/10.1007/s40565-019-0527-4>



- Bertsimas, D., Tsitsiklis, J.N., 1997. Introduction to linear optimization. Athena Scientific.
- Bistline, J., Cole, W., Damato, G., DeCarolis, J., Frazier, W., Linga, V., Marcy, C., Namovicz, C., Podkaminer, K., Sims, R., Sukunta, M., Young, D., 2020. Energy storage in long-term system models: a review of considerations, best practices, and research needs. *Prog. Energy* 2, 032001. <https://doi.org/10.1088/2516-1083/ab9894>
- Child, M., Kemfert, C., Bogdanov, D., Breyer, C., 2019. Flexible electricity generation, grid exchange and storage for the transition to a 100% renewable energy system in Europe. *Renew. Energy* 139, 80–101. <https://doi.org/10.1016/j.renene.2019.02.077>
- Cochran, J., Miller, M., Zinaman, O., Milligan, M., Arent, D., Palmintier, B., O'Malley, M., Mueller, S., Lannoye, E., Tuohy, A., Kujala, B., Sommer, M., Holttinen, H., Kiviluoma, J., Soonee, S.K., 2014. Flexibility in 21st Century Power Systems (No. NREL/TP-6A20-61721, 1130630). <https://doi.org/10.2172/1130630>
- Cornuéjols, G., 2007. Valid inequalities for mixed integer linear programs. *Math. Program.* 112, 3–44. <https://doi.org/10.1007/s10107-006-0086-0>
- Danish Energy Agency, 2018a. Technology Data for Generation of Electricity and District Heating [WWW Document]. Energistyrelsen. URL <https://ens.dk/en/our-services/projections-and-models/technology-data/technology-data-generation-electricity-and> (accessed 6.22.21).
- Danish Energy Agency, 2018b. Technology Data for Energy Storage [WWW Document]. Energistyrelsen. URL <https://ens.dk/en/our-services/projections-and-models/technology-data/technology-data-energy-storage> (accessed 6.22.21).
- de Groot, M., Crijns-Graus, W., Harmsen, R., 2017. The effects of variable renewable electricity on energy efficiency and full load hours of fossil-fired power plants in the European Union. *Energy* 138, 575–589. <https://doi.org/10.1016/j.energy.2017.07.085>
- Denholm, P., O'Connell, M., Brinkman, G., Jorgenson, J., 2015. Overgeneration from Solar Energy in California: A Field Guide to the Duck Chart. National Renewable Energy Laboratory.
- Diaz, G., Inzunza, A., Moreno, R., 2019. The importance of time resolution, operational flexibility and risk aversion in quantifying the value of energy storage in long-term energy planning studies. *Renew. Sustain. Energy Rev.* 112, 797–812. <https://doi.org/10.1016/j.rser.2019.06.002>
- EAFO, 2019. European vehicle categories [WWW Document]. URL <https://www.eafo.eu/knowledge-center/european-vehicle-categories> (accessed 6.21.21).
- EASE, 2020. EASE Study on Power System Challenges of Islands and Isolated Systems with High Shares of Variable Renewables. European Association for Storage of Energy, Brussels.
- EIA, n.d. Electric Utility Demand Side Management [WWW Document]. URL <https://www.eia.gov/electricity/data/eia861/dsm/>
- Ericson, T., Halvorsen, B., 2008. Kortsiktige variasjoner i strømforbruket i alminnelig forsyning - Forbrukskurver basert på timesmålte data fra Skagerak Nett [WWW Document]. ssb.no. URL <https://www.ssb.no/energi-og-industri/artikler-og-publikasjoner/kortsiktige-variasjoner-i-stromforbruket-i-alminnelig-forsyning> (accessed 6.21.21).
- European Commission, 2018. Clean Energy for Islands Initiative.
- European Commission, 2017. Clean energy for EU islands [WWW Document]. *Energy - Eur. Comm.* URL https://ec.europa.eu/energy/topics/markets-and-consumers/clean-energy-eu-islands_en (accessed 3.13.21).
- European Commission. Joint Research Centre., 2018. Li-ion batteries for mobility and stationary storage applications: scenarios for costs and market growth. Publications Office, LU.
- European Union, 2019. Clean energy for all Europeans. Publications Office of the European Union, Luxembourg.



- Greening the Grid, 2014. Ancillary Services [WWW Document]. URL <https://greeningthegrid.org/integration-in-depth/ancillary-services> (accessed 6.19.21).
- Guerassimoff, G., Maizi, N., Mastère OSE, 2008, 2008. *Iles et Energies: un paysage de contrastes*, Collection Développement Durable. Presses des MINES.
- Hafenstrom, 2020. E-ferry battery and charging (GIFT project). URL <https://hafenstrom.com/e-ferry-battery-and-charging-gift-project/> (accessed 6.29.21).
- HIDALGO GONZÁLEZ, I., RUIZ CASTELLO, P., SGOBBI, A., NIJS, W., QUOILIN, S., ZUCKER, A., THIEL, C., 2015. Addressing flexibility in energy system models (No. Report EUR 27183 EN). Publications Office of the European Union, LU.
- HLK, 2020 GIFT Deliverable D7.1 Report on Requirement and Prosumer Analysis with installation project documentation <https://www.gift-h2020.eu/wp-content/uploads/2021/02/D7.1-Report-on-Requirement-and-Prosumer-Analysis-with-installation-project-documentation.pdf>
- IEA, 2020. Introduction to System Integration of Renewables. International Energy Agency, Paris.
- IEA, 2019. Status of Power System Transformation 2019 32.
- IRENA, 2030. Electricity storage and renewables: Costs and markets to 2030. International Renewable Energy Agency, Abu Dhabi.
- IRENA, 2020a. Renewable Power Generation Costs in 2019. International Renewable Energy Agency, Abu Dhabi.
- IRENA, 2020b. Electricity Storage Valuation Framework [WWW Document]. Publ.-Storage-Valuat.-Framew.-2020. URL </publications/2020/Mar/Electricity-Storage-Valuation-Framework-2020> (accessed 3.24.21).
- IRENA, 2019. Innovation landscape for a renewable-powered future: solutions to integrate variable renewables. International Renewable Energy Agency, Abu Dhabi.
- IRENA, 2018a. Power system flexibility for the energy transition [WWW Document]. Publ.-Syst.-Flex.---Energy-Transit. URL </publications/2018/Nov/Power-system-flexibility-for-the-energy-transition> (accessed 1.21.21).
- IRENA, 2018b. Transforming Small-Island Power Systems 150.
- ISTAT, 2019. Statistiche ISTAT [WWW Document]. URL <http://dati.istat.it/?lang=en>
- JRC, 2019a. PVGIS users manual [WWW Document]. EU Sci. Hub - Eur. Comm. URL <https://ec.europa.eu/jrc/en/PVGIS/docs/usermanual> (accessed 6.19.21).
- JRC, 2019b. JRC Photovoltaic Geographical Information System (PVGIS) - European Commission [WWW Document]. URL https://re.jrc.ec.europa.eu/pvg_tools/fr/ (accessed 6.19.21).
- Knezović, K., 2016. Active integration of electric vehicles in the distribution network – theory, modelling and practice 229.
- Leisch, J., Cochran, J., 2015. Sources of operational flexibility 2.
- Loulou, Richard, Goldstein, G., Kanudia, A., Lettila, A., Remme, U., 2016. Documentation for the TIMES Model - Part I.
- Loulou, R., Remme, U., Kanudia, A., Lehtila, A., Goldstein, G., 2016. Documentation for the TIMES Model. Part I&II.
- Madslie, A., Hulleberg, N., Kwong, C.K., 2019. Framtidens transportbehov Framskrivinger for person- og godstransport 2018-2050 (in Norwegian). Transport in the future. Projections for passenger and freight transport 2018-2050. The Institute of Transport Economics (TØI) Oslo, Norway. p. 64.
- Morrison, D.R., Jacobson, S.H., Sauppe, J.J., Sewell, E.C., 2016. Branch-and-bound algorithms: A survey of recent advances in searching, branching, and pruning. *Discrete Optim.* 19, 79–102. <https://doi.org/10.1016/j.disopt.2016.01.005>



- Norwegian Electric Vehicle Association, 2021. Norwegian EV policy and market [WWW Document]. URL <https://elbil.no/english/> (accessed 6.19.21).
- Norwegian Ministry, of Climate and Environment, 2016. Meld. St. 41 (2016 – 2017) Report to the Storting (white paper) 118.
- Norwegian Ministry of Petroleum and Energy, Norwegian Ministry of Climate and Environment, 2020. The Norwegian Government's hydrogen strategy 56.
- NTNU, 2020. TIMES Hinnoya model documentation v4.
- NVE, 2021. Kraftproduksjon [WWW Document]. URL <https://www.nve.no/energiforsyning/kraftproduksjon/?ref=mainmenu> (accessed 6.29.21).
- NVE, 2020. Vindkraftdata [WWW Document]. URL <https://www.nve.no/energiforsyning/kraftproduksjon/vindkraft/vindkraftdata/> (accessed 6.29.21).
- NVE, 2019a. Langsiktig kraftmarkedsanalyse - Long-Term Power Market Analysis [WWW Document]. URL <https://www.nve.no/energiforsyning/kraftmarkedsdata-og-analyser/langsiktig-kraftmarkedsanalyse/?ref=mainmenu> (accessed 6.21.21).
- NVE, 2019b. Kostnader for kraftproduksjon [WWW Document]. URL <https://www.nve.no/energiforsyning/kraftmarkedsdata-og-analyser/kostnader-for-kraftproduksjon/?ref=mainmenu> (accessed 6.22.21).
- Terna, 2019. Documento di Descrizione degli Scenari 2019.
- Padberg, M., Rinaldi, G., 1991. A Branch-and-Cut Algorithm for the Resolution of Large-Scale Symmetric Traveling Salesman Problems. *SIAM Rev.* 33, 60–100.
- Pasaoglu, G., Fiorello, D., Zani, L., Martino, A., Zubaryeva, A., Thiel, C., 2013. Projections for Electric Vehicle Load Profiles in Europe Based on Travel Survey Data. Publications Office of the European Union, Luxembourg.
- Poncelet, K., Delarue, E., D'haeseleer, W., 2018. Integrating flexibility constraints in long-term planning models: impact, pitfalls and modeling recommendations 16.
- Poncelet, K., Delarue, E., Six, D., Duerinck, J., D'haeseleer, W., 2016. Impact of the level of temporal and operational detail in energy-system planning models. *Appl. Energy* 162, 631–643. <https://doi.org/10.1016/j.apenergy.2015.10.100>
- Postic, S., 2015. Long-term energy prospective modeling for South America - Application to international climate negotiations (Environmental Engineering). Ecole Nationale Supérieure des Mines de Paris.
- Rios, I., 2016. Analyzing the Usage Patterns of Electric Bikes.
- SSB, 2019. 10314: Net consumption of electricity, by consumer group (GWh) (M) 2010 - 2019 [WWW Document]. PX-Web SSB. URL <http://www.ssb.no/en/statbanken/statbank/table/10314/> (accessed 6.29.21).
- SSB, 2018. Lower population growth in future [WWW Document]. ssb.no. URL <https://www.ssb.no/en/befolkning/artikler-og-publikasjoner/lower-population-growth-in-future> (accessed 6.21.21).
- Turton, H., Moura, F., 2008. Vehicle-to-grid systems for sustainable development: An integrated energy analysis. *Technol. Forecast. Soc. Change* 75, 1091–1108. <https://doi.org/10.1016/j.techfore.2007.11.013>
- UN Environment, 2017. Mitigation [WWW Document]. UNEP - UN Environ. Programme. URL <http://www.unep.org/explore-topics/climate-action/what-we-do/mitigation> (accessed 6.24.21).
- Van Nuffel, L., 2018. Sector coupling: how can it be enhanced in the EU to foster grid stability and decarbonise? 64.



- Welsch, M., Deane, P., Howells, M., Ó Gallachóir, B., Rogan, F., Bazilian, M., Rogner, H.-H., 2014. Incorporating flexibility requirements into long-term energy system models – A case study on high levels of renewable electricity penetration in Ireland. *Appl. Energy* 135, 600–615. <https://doi.org/10.1016/j.apenergy.2014.08.072>
- Wolsey, L.A., Nemhauser, G.L., 1999. *Integer and Combinatorial Optimization*, Wiley Series in Discrete Mathematics & Optimization. Wiley-Blackwell.
- Zhou W. and Assefa Hagos D., W., Assefa Hagos, D., Stikbakke, S., Liu, Y., Huang, L., Cheng, X., Onstein, E., 2020. Achieving deep decarbonization of Norway’s island energy system and its policy implications – the case of the Hinnøya island.