



HAL
open science

The dimension of the moduli spaces of curves defined by topologically non quasi-homogeneous functions

Jinan Loubani

► **To cite this version:**

Jinan Loubani. The dimension of the moduli spaces of curves defined by topologically non quasi-homogeneous functions. *Journal of Symbolic Computation*, 2021, 104, pp.207 - 235. 10.1016/j.jsc.2020.04.014 . hal-03493773

HAL Id: hal-03493773

<https://hal.science/hal-03493773>

Submitted on 15 Dec 2022

HAL is a multi-disciplinary open access archive for the deposit and dissemination of scientific research documents, whether they are published or not. The documents may come from teaching and research institutions in France or abroad, or from public or private research centers.

L'archive ouverte pluridisciplinaire **HAL**, est destinée au dépôt et à la diffusion de documents scientifiques de niveau recherche, publiés ou non, émanant des établissements d'enseignement et de recherche français ou étrangers, des laboratoires publics ou privés.



Distributed under a Creative Commons Attribution - NonCommercial 4.0 International License

The dimension of the moduli spaces of curves defined by topologically non quasi-homogeneous functions.

Jinan Loubani

Institut de Mathématiques de Toulouse, Université Paul Sabatier, 118 route de Narbonne, 31062 Toulouse cedex 9, France.

Dipartimento di Matematica "F. Casorati", Università degli Studi di Pavia, Via Ferrata, 5 - 27100 Pavia, Italy.

Abstract

We consider a topological class of a germ of complex analytic function in two variables which does not belong to its jacobian ideal. Such a function is not quasi homogeneous. The 0-level of such a function defines a germ of analytic curve. Proceeding similarly to the homogeneous case [Genzmer and Paul \(2011\)](#) and the quasi homogeneous case [Genzmer and Paul \(2016\)](#), we describe an algorithm which computes the dimension of the generic strata of the local moduli space of curves.

Keywords: moduli of curve, singularities.

1. Introduction.

A germ of holomorphic function $f : (\mathbb{C}^2, 0) \rightarrow (\mathbb{C}, 0)$ is said to be *quasi-homogeneous* if and only if f belongs to its jacobian ideal $J(f) = (\frac{\partial f}{\partial x}, \frac{\partial f}{\partial y})$. If f is quasi-homogeneous, then there exist coordinates (x, y) and positive coprime integers k and l such that the quasi-radial vector field $R = kx\frac{\partial}{\partial x} + ly\frac{\partial}{\partial y}$ satisfies $R(f) = d \cdot f$, where the integer d is the *quasi-homogeneous* (k, l) -degree of f [Saito \(1971\)](#). Based on that, the following family of functions

$$f_{M,N} = \prod_{i=1}^N (y + a_i x) \prod_{i=1}^M (y + b_i x^2)$$

is not quasi homogeneous. We denote by $\mathcal{T}_{M,N}$ the set of holomorphic functions which are topologically equivalent to $f_{M,N}$. This topological class is the simplest one beyond the quasi-homogeneous singularities. In [Loubani \(2019\)](#), we described the moduli space $\mathcal{M}_{M,N}$ of foliations, which is the topological class $\mathcal{T}_{M,N}$ up to right-left equivalence, and gave local analytic normal forms. In this article, we study the dimension of the moduli space of the curve $S = \{f_{M,N} = 0\}$.

This problem is a particular case of an open problem known as the *Zariski problem*. Zariski problem has only some answers: [Zariski \(1986\)](#) for the very first treatment of some particular cases,

Email addresses: Jinan.Loubani@math.univ-toulouse.fr (Jinan Loubani),
jinan.loubani01@universitadipavia.it (Jinan Loubani)

Preprint submitted to Elsevier

April 24, 2020

Hefez and Hernandez (2009), Hefez and Hernandez (2011) and Hefez and Hernandez (2013) for the irreducible curves, Granger (1979) and Genzmer and Paul (2011) for the homogeneous topological class and J. Briancon and Maisonobe (1988) for some results which are particular cases of the quasi homogeneous topological class treated later by Genzmer and Paul (2016).

Since the topological class $\mathcal{T}_{M,N}$ is the simplest one beyond the quasi-homogeneous singularities, solving Zariski problem for this class would be the first step towards solving it for the remaining cases and consequently for the general case. In our work, we follow the strategy introduced by Genzmer and Paul: on the moduli space of foliations $\mathcal{M}_{M,N}$, we consider the integrable distribution \mathcal{C} related to the following equivalence relation: two points in $\mathcal{M}_{M,N}$ are equivalent if and only if the separatrices of the corresponding class of foliations are in the same analytic class of curves. In section 3, we describe the infinitesimal generators of the distribution \mathcal{C} . The main result of this section is proposition 3.2 in which we show the algebraic independence of some coefficients of the \mathcal{O}_2 -generator of \mathcal{C} . Section 4 presents an algorithm to compute the dimension of the generic strata of the local moduli space of curves (Theorem A). Finally, we give some examples in section 5. Section 2 is devoted to recalling some needed definitions and notions.

2. Definitions and Notions.

The strategy introduced by Genzmer and Paul Genzmer and Paul (2016) is based on the deformation theory introduced by Jean-François Mattei in Mattei (1991). In view of that, we need to recall the following concepts.

Definition 2.1. *Let \mathcal{F}_0 be a germ of holomorphic foliation at $0 \in \mathbb{C}^2$ with isolated singularity 0. An unfolding of \mathcal{F}_0 of base $P = (\mathbb{C}^p, 0)$ is the data of a germ of saturated foliation \mathcal{F}_p of codimension 1 at the origin of $(\mathbb{C}^{2+p}, 0)$ of singular set $\Sigma(\mathcal{F}_p)$ such that the leaves of \mathcal{F}_p are transverse to the fibers of the projection*

$$\Pi : (\mathbb{C}^{2+p}, 0) \rightarrow P, \quad \Pi(x, t) = t,$$

with $x = (x_1, x_2), t = (t_1, \dots, t_p)$, and such that we have the equality

$$i^*(\mathcal{F}_p) = \mathcal{F}_0,$$

where $i : (\mathbb{C}^2, 0) \hookrightarrow (\mathbb{C}^{2+p}, 0)$ designs the embedding $i(x) = (x, 0)$.

In other words, it is the data of a germ of holomorphic 1-form

$$\Omega = A_1(x, t)dx_1 + A_2(x, t)dx_2 + \sum_{j=1}^p C_j(x, t)dt_j, \quad (1)$$

such that

1. A_1, A_2 and C_1, \dots, C_p are germs of holomorphic functions at a neighborhood of $\{0\}$,
2. Ω is integrable, i.e. $\Omega \wedge d\Omega \equiv 0$,
3. The singular set $\Sigma(\mathcal{F}_p)$ is the zero set of the ideal $(A_1, A_2, C_1, \dots, C_p) \subset \mathcal{O}_{2+p}$,
4. (C_1, \dots, C_p) is a sub-ideal of $\sqrt{(A_1, A_2)}$.

The last condition corresponds to the transversality of the leaves and the fibers.

Two unfoldings \mathcal{F}_p and \mathcal{F}'_p of the same base P are said to be *holomorphically conjugated*, or *equivalent*, if there exists a germ of holomorphic automorphism ϕ of $(\mathbb{C}^{2+p}, 0)$ such that

$$\phi^*\mathcal{F}_p = \mathcal{F}'_p \text{ and } \Pi \circ \phi = \Pi.$$

When ϕ is only a C^k -homeomorphism, we say that \mathcal{F}_p and \mathcal{F}'_p are C^k -conjugated. An unfolding \mathcal{F}_p is said to be trivial if it is conjugated to a constant unfolding $\mathcal{F}_0 \times P$, i.e. defined by (1) with

$$A_i(x, t) \equiv A_i(x, 0), \quad C_j(x, t) \equiv 0, \quad i = 1, 2, \quad j = 1, \dots, p.$$

The equireducibility of an unfolding corresponds to the existence of reduction of singularities in family as precised in [Mattei \(1991\)](#). An equireducible unfolding is in particular a topologically trivial deformation [Mattei \(1991\)](#). This property is essential and is the only property we need here about equireducible unfoldings because as we work with a fixed topological class, we have to make sure that any deformation we consider does not change the class.

3. The infinitesimal generators of \mathcal{C} .

We first recall general facts proved in [Genzmer and Paul \(2011\)](#), which are valid in every topological class. Let \mathcal{F} be a foliation defined by a holomorphic function f (or more generally by any generic non dicritical differential form ω), and let S be the curve defined by $f = 0$ (or by the separatrix set of ω). Let $E : M \rightarrow (\mathbb{C}^2, 0)$ be the desingularization map of the foliation, and D its exceptional divisor. We denote by \tilde{f} , $\tilde{\mathcal{F}}$ and \tilde{S} the pull back by E on M of f , \mathcal{F} and S . The tangent space to the point $[S]$ in the moduli space of curves is the first Čech cohomology group $H^1(D, \Theta_S)$ where Θ_S is the sheaf on D of germs of vector fields tangent to \tilde{S} [Mattei \(2000\)](#). Denoting by $\Theta_{\mathcal{F}}$ the sheaf of germs of vector fields tangent to the desingularized foliation $\tilde{\mathcal{F}}$, the inclusion of $\Theta_{\mathcal{F}}$ into Θ_S induces a map i :

$$H^1(D, \Theta_{\mathcal{F}}) \xrightarrow{i} H^1(D, \Theta_S)$$

whose kernel represents the directions of unfolding of foliations with trivial associate unfolding of curves. We recall that according to [Mattei \(1991\)](#), the tangent space to the moduli space of foliations is given by the cohomology group $H^1(D, \Theta_{\mathcal{F}})$. Therefore, to compute the dimension of the generic strata of the local moduli space of curves, which is equivalent to computing the dimension of the cohomology group $H^1(D, \Theta_S)$, we need to study two objects: the cohomology group $H^1(D, \Theta_{\mathcal{F}})$ and the kernel of the map i .

To study the kernel of the map i , we shall make use of a result by Genzmer and Paul [Genzmer and Paul \(2011\)](#). Before stating this result, we need the following definition:

Definition 3.1. *An open set U of M is a quasi-homogeneous open set (relatively to f) if there exists a holomorphic vector field R_U on U such that $R_U(\tilde{f}) = \tilde{f}$.*

The foliations induced by the elements of $\mathcal{T}_{M,N}$ can be desingularized after two standard blow-ups of points.

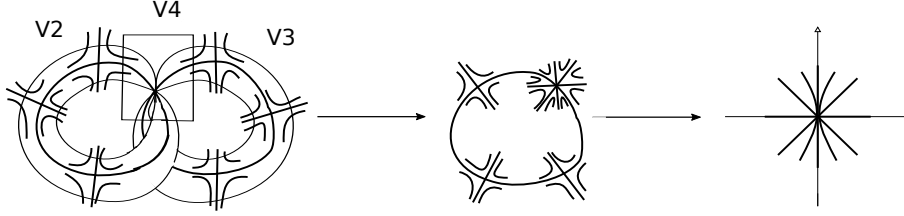

Figure 1: Desingularization of $f_{M,N}$ for $M = N = 3$

Since the invariant curves of the desingularized foliations are smooth, we can always cover D by three quasi-homogeneous open sets V_2 , V_3 and V_4 . For $i=2,3,4$, we denote the corresponding holomorphic vector field R_{V_i} by R_i to simplify the notation. The cocycle of the quasi-homogeneity $[R_{3,4}, R_{2,4}]$ of \mathcal{F} is the element of $H^1(D, \Theta_{\mathcal{F}})$ induced by $(R_3 - R_4, R_2 - R_4)$.

Noting that $H^1(D, \Theta_{\mathcal{F}})$ has a natural structure of \mathcal{O}_2 -module, we have:

Theorem (Genzmer and Paul (2011)). *The kernel of the map i is generated by the cocycle of quasi-homogeneity, i.e.:*

$$\ker(i) = \{h \cdot [R_{3,4}, R_{2,4}], h \in \mathcal{O}_2\}.$$

In particular, the distribution induced by these directions is integrable and defines a singular foliation \mathcal{C} on $H^1(D, \Theta_{\mathcal{F}})$.

For $H^1(D, \Theta_{\mathcal{F}})$, we know from Loubani (2019) that its basis is in bijection with \mathcal{P} which is the open set of \mathbb{C}^δ defined by

$$\mathcal{P} = \left\{ (\dots, a_{k,i}, \dots, b_{k',i'}, \dots) \text{ such that } a_{1,i} \neq 0, b_{1,j} \neq 0, 1 \text{ and} \right. \\ \left. a_{1,i} \neq a_{1,j}, b_{1,i'} \neq b_{1,j'} \text{ for } i \neq j \text{ and } i' \neq j' \right\},$$

where the indexes k, i, k' and i' satisfy the following system of inequalities

$$\begin{cases} 0 \leq k-1 \leq i-1 \\ -(N-2) \leq 2k-i-1 \leq 2i-2 \\ -(M-2) \leq k'-i'-1 \leq N-3+2i' \\ 0 \leq k'-1 \leq N-2+2i'. \end{cases}$$

We also know from the same work that the dimension δ of $H^1(D, \Theta_{\mathcal{F}})$ is equal to the number of the integer points in the region $\mathcal{Q}_{M,N}$ in the union of the real half planes (X, Y) , $X \geq 0$ and $Y \geq 0$, delimited by $Y - X + (M - 1) > 0$ and $2Y - X - (N - 1) < 0$.

For $p \in \mathcal{P}$, we consider the saturated foliation $\mathcal{F}_p^{(M,N)}$ defined by the one-form $dN_p^{(M,N)}$ on $\mathbb{C}^{2+\delta}$, where

$$N_p^{(M,N)} = xy(y+x^2) \prod_{i=1}^{N-1} \left(y + \sum_{k=1}^i a_{k,i} xy^{k-1} \right) \prod_{i=1}^{M-2} \left(y + \sum_{k=1}^{N-1+2i} b_{k,i} x^{k+1} \right).$$

We would make use of the following result:

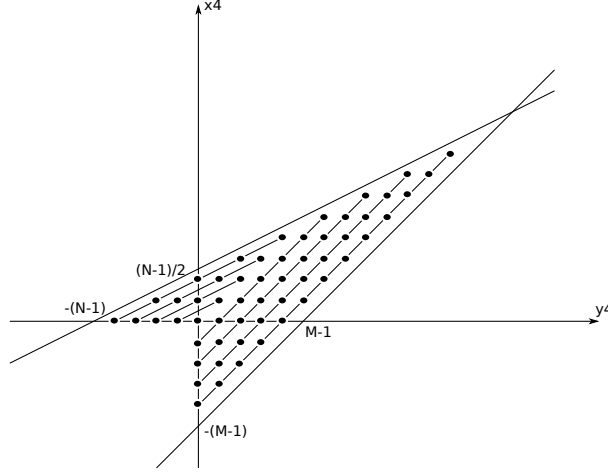

Figure 2: The region $Q_{M,N}$ for $M = N = 6$

Theorem 3.1 (Loubani (2019)). *For any p_0 in \mathcal{P} the germ of unfolding $\{\mathcal{F}_p^{(M,N)}, p \in (\mathcal{P}, p_0)\}$ is a universal equireducible unfolding of the foliation $\mathcal{F}_{p_0}^{(M,N)}$.*

The universality means that for any equireducible unfolding \mathcal{F}_t , $t \in (\mathcal{T}, t_0)$ which defines $\mathcal{F}_{p_0}^{(M,N)}$ for $t = t_0$, there exists a map $\lambda : (\mathcal{T}, t_0) \rightarrow (\mathcal{P}, p_0)$ such that the family \mathcal{F}_t is analytically equivalent to $N_{\lambda(t)}^{(M,N)}$. Furthermore, the differential of λ at the point t_0 is unique. As for the uniqueness of the map λ , it follows from the uniqueness of the normal forms which is proved in Loubani (2019).

This theorem shows that the family of foliations $(dN_p^{(M,N)})_{p \in \mathcal{P}}$ defines the moduli space of foliations $\mathcal{M}_{M,N}$ locally, or equivalently the family of germs of vector fields induced by the family of germs of functions $(N_p^{(M,N)})_{p \in \mathcal{P}}$ defines the space $H^1(D, \Theta_{\mathcal{F}})$. Thus, our study reduces to studying the action of the distribution \mathcal{C} on this family of functions.

Let $X_{m,n}$ be the vector fields on \mathcal{P} generated by $x^m y^n \cdot [R_{3,4}, R_{2,4}]$. We give the expression of $X_{0,0}$ in the basis $\left\{ \frac{\partial}{\partial a_{k,i}}, \frac{\partial}{\partial b_{k,i}} \right\}_{k,i}$ of the vector space generated by the set \mathcal{P} :

Proposition 3.1. *The \mathcal{O}_2 -generator of \mathcal{C} is given by:*

$$\begin{aligned} X_{0,0} &= [R_3 - R_4, R_2 - R_4] \\ &= \frac{-1}{2M+2N-1} \left(\sum_{i=1}^{N-1} \sum_{k=1}^i (2k-3) a_{k,i} \frac{\partial}{\partial a_{k,i}} + \sum_{i=1}^{M-2} \sum_{k=1}^{N-1+2i} (k-1) b_{k,i} \frac{\partial}{\partial b_{k,i}} \right). \end{aligned}$$

Proof. Let p be in \mathcal{P} and consider the following deformation

$$(\lambda, p) \in (\mathbb{C}, 1) \times (\mathcal{P}, p) \mapsto N_{p,\lambda}(x, y) = N_p(\lambda x, \lambda^2 y) = \lambda^{2M+2N-1} N_{\lambda \cdot p}(x, y),$$

where $\lambda \cdot p = \lambda \cdot (a_{k,i}, b_{k,i}) = (\lambda^{2k-3} a_{k,i}, \lambda^{k-1} b_{k,i})$ and we denote the normal form $N_p^{(M,N)}$ by N_p for simplicity. This deformation is analytically trivial in λ . Hence, its related cocycle is trivial.

Blowing the deformation up yields

$$\tilde{N}_{p,\lambda}(x_4, y_4) = \lambda^{2M+2N-1} x_4^{M+N} y_4^{2M+N} (1+x_4) \prod_{i=1}^{N-1} \left(y_4 + \sum_{k=1}^i \lambda^{2k-3} a_{k,i} x_4^{k-1} y_4^{2k-2} \right) \prod_{i=1}^{M-2} \left(1 + \sum_{k=1}^{N-1+2i} \lambda^{k-1} b_{k,i} x_4^k y_4^{k-1} \right),$$

and so we have

$$\tilde{N}_{p,\lambda}^{-1} \frac{\partial \tilde{N}_{p,\lambda}}{\partial \lambda} = (2M+2N-1)\lambda^{-1} + \sum_{i=1}^{N-1} \frac{\sum_{k=1}^i (2k-3) \lambda^{2k-4} a_{k,i} x_4^{k-1} y_4^{2k-2}}{y_4 + \sum_{k=1}^i \lambda^{2k-3} a_{k,i} x_4^{k-1} y_4^{2k-2}} + \sum_{i=1}^{M-2} \frac{\sum_{k=1}^{N-1+2i} (k-1) \lambda^{k-2} b_{k,i} x_4^k y_4^{k-1}}{1 + \sum_{k=1}^{N-1+2i} \lambda^{k-1} b_{k,i} x_4^k y_4^{k-1}}.$$

The vector field R_4 is defined as a solution on V_4 of $R_4 \tilde{N}_p = \tilde{N}_p$. Moreover, according to [Loubani \(2019\)](#), $\frac{\partial}{\partial a_{k,i}}$ and $\frac{\partial}{\partial b_{k,i}}$ are defined by the cocycle related to the vector fields $X_{k,i}^{(j)}$ and $Y_{k,i}^{(j)}$ respectively such that $X_{k,i}^{(j)} \tilde{N}_p = \frac{\partial \tilde{N}_p}{\partial a_{k,i}}$ and $Y_{k,i}^{(j)} \tilde{N}_p = \frac{\partial \tilde{N}_p}{\partial b_{k,i}}$. Setting $\lambda = 1$, we obtain

$$\begin{aligned} \frac{\partial \tilde{N}_{p,\lambda}}{\partial \lambda} \Big|_{\lambda=1} &= \left((2M+2N-1)R_4 + \sum_{i=1}^{N-1} \sum_{k=1}^i (2k-3) a_{k,i} X_{k,i}^{(4)} \right. \\ &\quad \left. + \sum_{i=1}^{M-2} \sum_{k=1}^{N-1+2i} (k-1) b_{k,i} Y_{k,i}^{(4)} \right) \tilde{N}_{p,\lambda} \\ &= C^{(4)} \tilde{N}_{p,\lambda}. \end{aligned}$$

The same computation in the other two charts leads to

$$\begin{aligned} C^{(3)} &= \left((2M+2N-1)R_3 + \sum_{i=1}^{N-1} \sum_{k=1}^i (2k-3) a_{k,i} X_{k,i}^{(3)} + \sum_{i=1}^{M-2} \sum_{k=1}^{N-1+2i} (k-1) b_{k,i} Y_{k,i}^{(3)} \right) \\ C^{(2)} &= \left((2M+2N-1)R_2 + \sum_{i=1}^{N-1} \sum_{k=1}^i (2k-3) a_{k,i} X_{k,i}^{(2)} + \sum_{i=1}^{M-2} \sum_{k=1}^{N-1+2i} (k-1) b_{k,i} Y_{k,i}^{(2)} \right). \end{aligned}$$

The triviality of the cocycle induced by $(C^{(3)} - C^{(4)}, C^{(2)} - C^{(4)})$ ends the proof. \square

From now on, we denote by $q_k = \left\lfloor \frac{k+N-2}{2} \right\rfloor + M - k$ the number of integer points in the intersection between the region $\mathcal{Q}_{M,N}$ of moduli and the straight line of equation $(y_4 = k-1)$ if $N \leq k \leq N+2M-5$.

We consider the following two subspaces of the vector space generated by the set \mathcal{P}

$$\mathcal{P}_a = \text{Vect} \left\{ \frac{\partial}{\partial a_{k,i}} \right\}_{\substack{i=1, \dots, N-1 \\ k=1, \dots, i}} \quad \text{and} \quad \mathcal{P}_b = \text{Vect} \left\{ \frac{\partial}{\partial b_{k,i}} \right\}_{\substack{i=1, \dots, M-2 \\ k=1, \dots, N-1+2i}}.$$

For $1 \leq l_a \leq N - 1$ (respectively $1 \leq l_b \leq N + 2M - 5$), we denote by $\mathcal{P}_a^{l_a}$ (respectively $\mathcal{P}_b^{l_b}$) the level of height l_a (respectively l_b) of the subspace \mathcal{P}_a (respectively \mathcal{P}_b), i.e.

$$\mathcal{P}_a^{l_a} = \text{Vect} \left\{ \frac{\partial}{\partial a_{l_a, i}} \right\}_{i=l_a, \dots, N-1}$$

$$\mathcal{P}_b^{l_b} = \begin{cases} \text{Vect} \left\{ \frac{\partial}{\partial b_{l_b, i}} \right\}_{i=1, \dots, M-2} & \text{if } 1 \leq l_b \leq N \\ \text{Vect} \left\{ \frac{\partial}{\partial b_{l_b, i}} \right\}_{i=M-1-q_{l_b}, \dots, M-2} & \text{if } N+1 \leq l_b \leq N+2M-5. \end{cases}$$

We have the following direct decomposition of \mathcal{P}

$$\mathcal{P} = \bigoplus_{\substack{1 \leq l_b \leq N-1 \\ l_a=l_b}} \text{Vect} \left\{ \mathcal{P}_a^{l_a}, \mathcal{P}_b^{l_b} \right\} \oplus_{l_b=N}^{l_b=N+2M-5} \mathcal{P}_b^{l_b}.$$

Now, we consider the following two subsets of the region $Q_{M,N}$ corresponding to the subspaces \mathcal{P}_a and \mathcal{P}_b respectively

$$I_a = \left\{ (i, j) \mid 0 \leq i \leq N-2 \text{ and } -(N-2) + 2i \leq j \leq i \right\}$$

$$I_b = \left\{ (i, j) \mid 0 \leq j \leq N-1 \text{ and } -(M-2) + j \leq i \leq j-1 \right. \\ \left. N \leq j \leq N+2M-6 \text{ and } -(M-2) + j \leq i \leq j-1 - (M-2 - q_{j+1}) \right\},$$

where the levels l_a and l_b are given by the straight lines of equations $x_4 = l_a - 1$ and $y_4 = l_b - 1$ respectively.

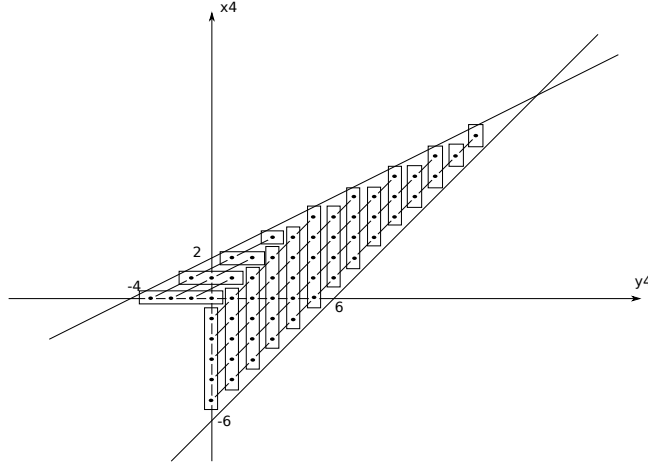

Figure 3: The Corresponding decomposition of the region $Q_{M,N}$ for $N = 5, M = 7$

Let Θ_0 be a holomorphic vector field with isolated singularities defining $\tilde{\mathcal{F}}_{p_0}^{(M,N)}$ on the two intersections $V_2 \cap V_4$ and $V_3 \cap V_4$. We denote by $[x_4^i y_4^j]$ the class of $x_4^i y_4^j (\Theta_0, 0)$ (respectively $x_4^i y_4^j (0, \Theta_0)$) in $H^1(D, \Theta_{\mathcal{F}_{p_0}^{(M,N)}})$ if $(i, j) \in I_a$ (respectively $(i, j) \in I_b$).

We can write the standard basis of $H^1(D, \Theta_{\mathcal{F}_{p_0}^{(M,N)}})$ as $B = B_a \cup B_b$ where

$$\begin{aligned} B_a &= \left\{ \left[x_4^i y_4^j \right] \mid (i, j) \in I_a \right\} \\ B_b &= \left\{ \left[x_4^i y_4^j \right] \mid (i, j) \in I_b \right\}. \end{aligned}$$

The following proposition is the basic tool for the proof of the main result of this article.

Proposition 3.2. *If we decompose the vector field $X_{0,0}$*

$$X_{0,0} = \frac{-1}{2M + 2N - 1} \left(\sum_{j=0}^{N-1} X_{0,0}^{a,j} \left[\frac{1}{y_4^j} \right] + \sum_{i=1}^{M-2} X_{0,0}^{b,i} \left[\frac{y_4}{x_4^{i-1}} \right] + \sum_{j=0}^{N-3} Y_{0,0}^{a,j} \left[\frac{x_4}{y_4^{j-1}} \right] \right) + \dots$$

where the dots correspond to the decomposition of $X_{0,0}$ at the levels l_a and l_b with $l_a \geq 3$ and $l_b \geq 3$, then the functions $X_{0,0}^{a,j}$ are the zero functions for $1 \leq j \leq N - 2$ and the functions $\{X_{0,0}^{a,0}, X_{0,0}^{b,i}, Y_{0,0}^{a,j}\}_{\substack{i=1,\dots,M-2 \\ j=0,\dots,N-3}}$ are algebraically independent.

Proof. Let us write the decomposition of the first term of the cocycle $\left\{ \frac{\partial}{\partial a_{1,l}}, \frac{\partial}{\partial b_{1,l}} \right\}$ in the standard basis of $H^1(D, \Theta_{\mathcal{F}_{p_0}^{(M,N)}})$

$$\frac{\partial}{\partial a_{1,l}} = \sum_{i,j \in B} R_{ij}^l(p) \left[x_4^i y_4^j \right],$$

where $p \in \mathcal{P}$. In view of theorem 3.1 and using the notation introduced in its proof, the first term of the cocycle associated to $\frac{\partial}{\partial a_{1,l}}$ is written $\{\Phi_{1,l}^{(3,4)}, \Phi_{1,l}^{(2,4)}\}$ where

$$\begin{aligned} \Phi_{1,l}^{(3,4)} &= \frac{1}{(2M+N)a_{1,l} \prod_{s=1}^{N-1} a_{1,s}} \left[\frac{\tilde{U}(x_4)}{x_4^{2M-2}} + W(x_4) \right] + y_4(\dots) \\ \Phi_{1,l}^{(2,4)} &= \frac{-1}{(M+N)(y_4+a_{1,l})} \left[\frac{\tilde{K}(y_4)}{y_4^{2N-2}} + B(y_4) \right] + x_4(\dots), \end{aligned}$$

with W is the polynomial function of degree $M - 1$ satisfying the Bezout identity

$$Q \wedge Q' = WQ' + ZQ, \quad Q(x_4) = x_4^{M+N} (1 + x_4) \prod_{j=1}^{N-1} a_{1,j} \prod_{j=1}^{M-2} (1 + b_{1,j} x_4),$$

\tilde{U} is a polynomial function in x_4 defined by the equality

$$\tilde{U}(x_4) = x_4^{M-1} U(y_3),$$

where U is the polynomial function of degree $M - 1$ satisfying the Bezout identity

$$P \wedge P' = UP' + VP, \quad P(y_3) = y_3(y_3 + 1) \prod_{j=1}^{N-1} a_{1,j} \prod_{j=1}^{M-2} (y_3 + b_{1,j}),$$

and B and \tilde{K} are polynomial functions of degree $N - 1$ in the variable y_4 satisfying relations similar to those satisfied by W and \tilde{U} .

In fact, $R_{-i,0}^l(p)$ is the coefficient of $\frac{1}{x_4^i}$ in the development of $\Phi_{1,l}^{(3,4)}$ in Laurent series, which is

zero for all $1 \leq i \leq M-2$ and $R_{0,-j}^l(p)$ is the coefficient of $\frac{1}{y_4^j}$ in the development of $\Phi_{1,l}^{(2,4)}$ which can be written as

$$\Phi_{1,l}^{(2,4)} = \frac{-1}{M+N} \left[\sum_{j=1}^{N-1} \frac{(-1)^{N+j-1} \tilde{K}(-a_{1,l})}{a_{1,l}^{N+j}} \frac{1}{y_4^{N-j-1}} + \frac{B(0)}{a_{1,l}} + \frac{R(y_4)}{y_4^{2N-2}} + y_4(\dots) \right] + x_4(\dots),$$

where R is a polynomial function of degree $N-1$.

For simplicity, we will replace the notation $R_{0,-j}^l(p)$ by $R_{0,j}^l(p)$. So, we can write $R_{0,j}^l(p)$ as follows

$$R_{0,j}^l(p) = \begin{cases} \frac{-1}{M+N} \left[\frac{\tilde{K}(-a_{1,l})}{a_{1,l}^{2N-1}} + \frac{B(0)}{a_{1,l}} \right] & \text{if } j=0 \\ \frac{1}{M+N} \frac{(-1)^{j-1} \tilde{K}(-a_{1,l})}{a_{1,l}^{2N-j-1}} & \text{if } 1 \leq j \leq N-2. \end{cases}$$

It is clear that $R_{0,j}^l(p)$ satisfies the following relation

$$\begin{cases} R_{0,0}^l(p) = -\frac{R_{0,1}^l(p)}{a_{1,l}} - \frac{1}{M+N} \frac{B(0)}{a_{1,l}} \\ R_{0,j}^l(p) = (-1)^{j-1} a_{1,l}^{j-1} R_{0,1}^l(p) \end{cases} \quad \text{if } 1 \leq j \leq N-2.$$

Thus, we obtain the following equality

$$\begin{aligned} \frac{\partial}{\partial a_{1,l}} &= -\frac{1}{M+N} \frac{B(0)}{a_{1,l}} + \sum_{j=0}^{N-2} (-a_{1,l})^{j-1} R_{0,1}^l(p) \left[\frac{1}{y_4^j} \right] + \sum_{\substack{B_a \\ i \neq 0}} \left\langle \frac{\partial}{\partial a_{1,l}}, x_4^i y_4^j \right\rangle [x_4^i y_4^j] \\ &+ \sum_{\substack{B_b \\ j \neq 0}} \left\langle \frac{\partial}{\partial a_{1,l}}, x_4^i y_4^j \right\rangle [x_4^i y_4^j]. \end{aligned}$$

where $\left\langle \frac{\partial}{\partial a_{1,l}}, x_4^i y_4^j \right\rangle$ denotes the coefficient of $[x_4^i y_4^j]$ in the decomposition of $\frac{\partial}{\partial a_{1,l}}$ on the standard basis of $H^1(D, \Theta_{\mathcal{F}_{p_0}}^{(M,N)})$.

Proposition 3.1 yields a decomposition of the cocycle $X_{0,0}$ in the standard basis which can be written as

$$\begin{aligned} X_{0,0} &= c \left(\sum_{j=0}^{N-2} X_{0,0}^{a,j} \left[\frac{1}{y_4^j} \right] + \sum_{i=1}^{M-2} X_{0,0}^{b,i} \left[\frac{y_4}{x_4^{i-1}} \right] + \sum_{j=0}^{N-3} Y_{0,0}^{a,j} \left[\frac{x_4}{y_4^{j-1}} \right] \right) \\ &+ c \left(\sum_{\substack{B_a, i \neq 0, 1 \\ B_b, j \neq 0, 1}} \sum_{l=1}^{N-1} -a_{1,l} \left\langle \frac{\partial}{\partial a_{1,l}}, x_4^i y_4^j \right\rangle [x_4^i y_4^j] + \sum_{\substack{B_a, i \neq 0, 1 \\ B_b, j \neq 0, 1}} \sum_{l=2}^{N-1} a_{2,l} \left\langle \frac{\partial}{\partial a_{2,l}}, x_4^i y_4^j \right\rangle [x_4^i y_4^j] \right. \\ &+ \sum_{\substack{B_b, j \neq 0 \\ B_a, i \neq 0, 1}} \sum_{l=1}^{M-2} b_{2,l} \left\langle \frac{\partial}{\partial b_{2,l}}, x_4^i y_4^j \right\rangle [x_4^i y_4^j] + \sum_{l=3}^{N-1} \sum_{k=3}^l (2k-3) a_{k,l} \frac{\partial}{\partial a_{k,l}} \\ &\left. + \sum_{l=1}^{M-2} \sum_{k=3}^{N-1+2l} (k-1) b_{k,l} \frac{\partial}{\partial b_{k,l}} \right) \end{aligned}$$

where

$$\begin{aligned}
X_{0,0}^{a,0} &= \frac{N-1}{M+N} B(0) + \sum_{l=1}^{N-1} R_{0,1}^l(p) \\
X_{0,0}^{a,j} &= \sum_{l=1}^{N-1} (-a_{1,l})^j R_{0,1}^l(p) \\
X_{0,0}^{b,i} &= \sum_{l=1}^{M-2} b_{2,l} \left\langle \frac{\partial}{\partial b_{2,l}}, \frac{y_4}{x_4^{i-1}} \right\rangle + \sum_{l=1}^{N-1} -a_{1,l} \left\langle \frac{\partial}{\partial a_{1,l}}, \frac{y_4}{x_4^{i-1}} \right\rangle \\
Y_{0,0}^{a,j} &= \sum_{l=1}^{M-2} b_{2,l} \left\langle \frac{\partial}{\partial b_{2,l}}, \frac{x_4}{y_4^{j-1}} \right\rangle + \sum_{l=2}^{N-1} a_{2,l} \left\langle \frac{\partial}{\partial a_{2,l}}, \frac{x_4}{y_4^{j-1}} \right\rangle + \sum_{l=1}^{N-1} -a_{1,l} \left\langle \frac{\partial}{\partial a_{1,l}}, \frac{x_4}{y_4^{j-1}} \right\rangle
\end{aligned}$$

and c is a constant given by

$$c = \frac{-1}{2M + 2N - 1}.$$

We note that the term $\left\langle \frac{\partial}{\partial a_{2,i}}, \frac{y_4}{x_4^{i-1}} \right\rangle$ is equal to zero for all $1 \leq i \leq M - 2$.

Now, according to the proof of theorem 3.1, $R_{0,1}^l(p)$ can be written as

$$R_{0,1}^l(p) = \frac{1}{M+N} \frac{(-1)^N}{a_{1,l} \prod_{\substack{j=1 \\ j \neq l}}^{N-1} (a_{1,l} - a_{1,j})}.$$

To compute the term $X_{0,0}^{a,0}$, we introduce the polynomial F_0 in the variable x_4 defined by

$$F_0(x_4) = \prod_{j=1}^{N-1} (x_4 - a_{1,j}).$$

Clearly, we have the following equality

$$\frac{1}{F_0(x_4)} = \sum_{j=1}^{N-1} \frac{1}{(x_4 - a_{1,j}) \prod_{\substack{j'=1 \\ j' \neq j}}^{N-1} (a_{1,j} - a_{1,j'})}.$$

So, we can write $X_{0,0}^{a,0}$ as

$$\begin{aligned}
X_{0,0}^{a,0} &= \frac{N-1}{M+N} B(0) + \frac{1}{M+N} \sum_{l=1}^{N-1} \frac{(-1)^N}{a_{1,l} \prod_{\substack{j=1 \\ j \neq l}}^{N-1} (a_{1,l} - a_{1,j})} \\
&= \frac{N-1}{M+N} B(0) + \frac{(-1)^{N+1}}{M+N} \frac{1}{F_0(0)}.
\end{aligned}$$

The initial expression of $F_0(x_4)$ implies that $F_0(0) = \prod_{j=1}^{N-1} (-a_{1,j})$. Since, from the proof of theorem 3.1, we have $B(0) = \frac{1}{(2M+N) \prod_{j=1}^{N-1} a_{1,j}}$, we obtain the following expression of $X_{0,0}^{a,0}$

$$X_{0,0}^{a,0} = \frac{2M + 2N - 1}{M + N} B(0),$$

which is different from zero.

Similarly, to compute the term $X_{0,0}^{a,j}$, we introduce the polynomial F_j in the variable x_4 defined by

$$F_j(x_4) = \frac{Q(x_4)}{P_j(x_4)}$$

where $Q(x_4) = \prod_{i=1}^{N-1} (x_4 - a_{1,i})$ and $P_j(x_4) = (-x_4)^j$ for all $1 \leq j \leq N-2$. Also, we have the following equality

$$\frac{1}{F_j(x_4)} = \sum_{i=1}^{N-1} \frac{(-a_{1,i})^j}{(x_4 - a_{1,i}) \prod_{\substack{i'=1 \\ i' \neq i}}^{N-1} (a_{1,i} - a_{1,i'})}$$

So, we can write $X_{0,0}^{a,j}$ as

$$X_{0,0}^{a,j} = \frac{(-1)^N}{M+N} \sum_{l=1}^{N-1} \frac{(-a_{1,l})^j}{a_{1,l} \prod_{\substack{j=1 \\ j \neq l}}^{N-1} (a_{1,l} - a_{1,j})} = \frac{(-1)^{N+1}}{F_j(0)}.$$

The initial expression of $F_j(x_4)$ implies that $X_{0,0}^{a,j} = 0$ for all $1 \leq j \leq N-2$.

Now, for the terms $X_{0,0}^{b,i}$, proceeding similarly to the proof of theorem 3.1, we can show that the term $\sum_{l=1}^{N-1} -a_{1,l} \left\langle \frac{\partial}{\partial a_{1,l}}, \frac{y_4}{x_4^{i-1}} \right\rangle$ is equal to the coefficient of $\frac{1}{x_4^i}$ in the development of $\sum_{l=1}^{N-1} -a_{1,l} \Phi_l(x_4)$ in Laurent series where $\Phi_l(x_4)$ is given by

$$\begin{aligned} \Phi_l(x_4) = & \frac{-(2M+N+1)}{(2M+N)^2 a_{1,l} \prod_{j=1}^{N-1} a_{1,j} (1+x_4)} \left(\frac{\tilde{U}(x_4)}{x_4^{2M-2}} + W(x_4) \right) \\ & \left(\frac{x_4}{\prod_{j=1}^{M-1} (1+b_{1,j}x_4)} \sum_{j=1}^{M-2} \frac{b_{2,j}}{1+b_{1,j}x_4} + \frac{\sum_{i=1}^{N-1} \frac{1}{a_{1,i}}}{x_4 \prod_{j=1}^{M-2} (1+b_{1,j}x_4)} \right) \\ & - \frac{1}{(2M+N)a_{1,l}^2 \prod_{j=1}^{N-1} a_{1,j}} \left(\frac{\tilde{U}(x_4)}{x_4^{2M-2}} + W(x_4) \right). \end{aligned}$$

Since $\frac{\partial}{\partial b_{2,l}} = x_4 y_4 \frac{\partial}{\partial b_{1,l}}$, then we have the following relation

$$\left\langle \frac{\partial}{\partial b_{2,l}}, \frac{y_4}{x_4^{i-1}} \right\rangle = \left\langle \frac{\partial}{\partial b_{1,l}}, \frac{1}{x_4^i} \right\rangle,$$

and so in view of the proof of theorem 3.1, the term $\sum_{l=1}^{M-2} b_{2,l} \left\langle \frac{\partial}{\partial b_{2,l}}, \frac{y_4}{x_4^{i-1}} \right\rangle$ is equal to the coefficient

of $\frac{1}{x_4^i}$ in the development of $\sum_{l=1}^{M-2} b_{2,l} x_4 \Psi_{1,l}^{(3,4)}(x_4)$ in Laurent series where $\Psi_{1,l}^{(3,4)}(x_4)$ is given by

$$\Psi_{1,l}^{(3,4)} = \frac{1}{(2M+N) \prod_{j=1}^{N-1} a_{1,j} (1+b_{1,l}x_4)} \left[\frac{\tilde{U}(x_4)}{x_4^{2M-3}} + x_4 W(x_4) \right] + y_4(\dots).$$

We can write

$$\begin{aligned} \prod_{j=1}^{N-1} a_{1,j} \sum_{l=1}^{N-1} -a_{1,l} \Phi_l(x_4) &= \frac{c_1}{(1+x_4) \prod_{j=1}^{M-2} (1+b_{1,j}x_4)} \frac{\tilde{U}(x_4)}{x_4^{2M-3}} \sum_{j=1}^{M-2} \frac{b_{2,j}}{1+b_{1,j}x_4} \\ &\quad + x_4(\dots) + \text{cst} + \dots \\ \prod_{j=1}^{N-1} a_{1,j} \sum_{l=1}^{M-2} b_{2,l} x_4 \Psi_{1,l}^{(3,4)}(x_4) &= \sum_{l=1}^{M-2} \frac{b_{2,l} x_4}{(2M+N)(1+b_{1,l}x_4)} \frac{\tilde{U}(x_4)}{x_4^{2M-3}} + x_4(\dots) + y_4(\dots), \end{aligned}$$

where $c_1 = \frac{(2M+N+1)(N-1)}{(2M+N)^2}$ and the dots stand for terms which do not contain $b_{2,j}$.

The coefficient of $b_{2,l}$ in the sum $\prod_{j=1}^{N-1} a_{1,j} \sum_{l=1}^{N-1} -a_{1,l} \Phi_l(x_4) + \prod_{j=1}^{N-1} a_{1,j} \sum_{l=1}^{M-2} b_{2,l} x_4 \Psi_{1,l}^{(3,4)}(x_4)$ is given by

$$E(x_4) = \frac{1}{x_4^{2M-3}} \frac{\tilde{U}(x_4)}{(1+b_{1,l}x_4)} \left[\frac{c_1}{(1+x_4) \prod_{j=1}^{M-2} (1+b_{1,j}x_4)} + c_2 x_4 \right]$$

where $c_2 = \frac{1}{2M+N}$. This implies that the coefficient of $b_{2,l}$ in the expression of $X_{0,0}^{b,i}$ is equal to the coefficient of $\frac{1}{x_4^{i-1}}$ in the previous expression.

The next part of the proof is devoted to showing that if we consider the functions $X_{0,0}^{b,i}$ as linear functions of the $M-2$ variables $b_{2,l}$, where $1 \leq l \leq M-2$, then their determinant is not the zero function. Hence, for a generic choice of the variables $b_{2,1}, \dots, b_{2,M-2}$, these $M-2$ linear functions are independent as linear functions of $M-2$ variables. Thus they are algebraically independent. In fact, we know that \tilde{U} is a polynomial function in x_4 defined by the equality

$$\tilde{U}(x_4) = x_4^{M-1} U(y_3)$$

where U is the polynomial function of degree $M-1$ satisfying the Bezout identity

$$P \wedge P' = UP' + VP.$$

Since we are interested in the generic independence, we restrict the proof to the following case

$$\begin{cases} \prod_{j=1}^{M-2} b_{1,j} = 1 & \text{and } (-b_{1,j})^{M-1} = -1 \quad \forall 1 \leq j \leq M-2 & \text{if } M \text{ is even} \\ \prod_{j=1}^{M-2} b_{1,j} = -1 & \text{and } (-b_{1,j})^{M-1} = 1 \quad \forall 1 \leq j \leq M-2 & \text{if } M \text{ is odd.} \end{cases}$$

So, the function P can be written as

$$P(y_3) = \begin{cases} \prod_{i=1}^{N-1} a_{1,i} y_3 (y_3^{M-1} + 1) & \text{if } M \text{ is even} \\ \prod_{i=1}^{N-1} a_{1,i} y_3 (y_3^{M-1} - 1) & \text{if } M \text{ is odd.} \end{cases}$$

If M is even, then using euclidean division, we find that \tilde{U} is given by

$$\tilde{U}(x_4) = x_4^{M-1} + \frac{M}{M-1}.$$

In this case, the expression E is equal to

$$E(x_4) = \frac{1}{x_4^{2M-3}} \frac{\tilde{U}(x_4)}{(1 + b_{1,l}x_4)} \left[\frac{c_1}{1 + x_4^{M-1}} + c_2x_4 \right].$$

From the proof of theorem 3.1, we have the following equality

$$\frac{\tilde{U}(x_4)}{(1 + b_{1,l}x_4)x_4^{2M-3}} = \sum_{j=0}^{M-2} d_{jl} \frac{1}{x_4^j} + \frac{T(x_4)}{x_4^{2M-3}} + x_4(\dots),$$

where T is a polynomial function in x_4 of degree $M-2$ and d_{jl} is given by

$$d_{jl} = (-1)^{j+1} b_{1,l}^{2M-j-3} \tilde{U} \left(\frac{-1}{b_{1,l}} \right).$$

In this case, we have

$$d_{jl} = \frac{(-1)^{j+1}}{M-1} b_{1,l}^{2M-j-3}$$

and the polynomial T satisfies the equality

$$\frac{T(x_4)}{x_4^{2M-3}} = \sum_{j=M-1}^{2M-3} c_{jl} \frac{1}{x_4^j},$$

where

$$c_{jl} = (-1)^{j-1} b_{1,l}^{2M-3-j} \frac{M}{M-1}.$$

Thus, the decomposition of $X_{0,0}^{b,i}$, where $1 \leq i \leq M-2$, on the family $b_{2,l}$, where $1 \leq l \leq M-2$, is given by the matrix

$$\begin{matrix} b_{2,1} \\ b_{2,2} \\ \vdots \\ b_{2,M-2} \end{matrix} \begin{pmatrix} X_{0,0}^{b,1} & X_{0,0}^{b,2} & \dots & X_{0,0}^{b,M-2} \\ c_2d_{1,1} + c_1d_{0,1} - c_1c_{M-1,1} & c_2d_{2,1} + c_1d_{1,1} - c_1c_{M,1} & \dots & c_2d_{M-2,1} + c_1d_{M-3,1} - c_1c_{2M-4,1} \\ c_2d_{1,2} + c_1d_{0,2} - c_1c_{M-1,2} & c_2d_{2,2} + c_1d_{1,2} - c_1c_{M,2} & \dots & c_2d_{M-2,2} + c_1d_{M-3,2} - c_1c_{2M-4,2} \\ \vdots & \vdots & \ddots & \vdots \\ c_2d_{1,M-2} + c_1d_{0,M-2} - c_1c_{M-1,M-2} & c_2d_{2,M-2} + c_1d_{1,M-2} - c_1c_{M,M-2} & \dots & c_2d_{M-2,M-2} + c_1d_{M-3,M-2} - c_1c_{2M-4,M-2} \end{pmatrix}.$$

From the expressions of $c_{i+M-2,l}$ and $d_{i-1,l}$, we have the following relation

$$d_{i-1,l} = -\frac{1}{M} c_{i+M-2,l}.$$

Since $d_{i,l} = -1/b_{1,l}d_{i-1,l}$, we can write the following

$$c_2d_{i,l} + c_1d_{i-1,l} - c_1c_{i+M-2,l} = \left[-\frac{1}{M} \left(c_1 - \frac{c_2}{b_{1,l}} \right) - c_1 \right] c_{i+M-2,l}.$$

Thus, the determinant of the above matrix is equal to

$$\left(\frac{M}{M-1}\right)^{M-2} \prod_{l=1}^{M-2} \left[\frac{1}{M} \left(c_1 - \frac{c_2}{b_{1,l}} \right) + c_1 \right] \text{Vand}(-b_{1,1}, \dots, -b_{1,M-2}),$$

which is not the zero function since $b_{1,i} \neq b_{1,j}$ for $i \neq j$.

The case where M is odd can be treated similarly.

Now, for the terms $Y_{0,0}^{a,j}$, we have

$$\left\langle \frac{\partial}{\partial b_{2,l}}, \frac{x_4}{y_4^{j-1}} \right\rangle = \left\langle \frac{\partial}{\partial b_{1,l}}, \frac{1}{y_4^j} \right\rangle = 0$$

for all $0 \leq j \leq N-3$. Since $\frac{\partial}{\partial a_{2,l}} = x_4 y_4^2 \frac{\partial}{\partial a_{1,l}}$, we have

$$\left\langle \frac{\partial}{\partial a_{2,l}}, \frac{x_4}{y_4^{j-1}} \right\rangle = \left\langle \frac{\partial}{\partial a_{1,l}}, \frac{1}{y_4^{j+1}} \right\rangle = (-a_{1,l})^j R_{0,1}^l(p)$$

for all $0 \leq j \leq N-3$.

Computations similar to those in the proof of theorem 3.1 show that the term

$\sum_{l=1}^{N-1} -a_{1,l} \left\langle \frac{\partial}{\partial a_{1,l}}, \frac{x_4}{y_4^{j-1}} \right\rangle$ is equal to the coefficient of $\frac{1}{y_4^{j-1}}$ in the development of $\sum_{l=1}^{N-1} -a_{1,l} \Psi_l(y_4)$ in Laurent series where $\Psi_l(y_4)$ is given by

$$\begin{aligned} \Psi_l(y_4) = & \frac{(M+N+1)}{(M+N)^2(y_4+a_{1,l})} \left[1 + \sum_{i=1}^{M-2} b_{1,i} + \sum_{i=2}^{N-1} \frac{a_{2,i} y_4^2}{y_4 + a_{1,i}} \right] \left[\frac{\tilde{K}(y_4)}{y_4^{2N-2}} + B(y_4) \right] \\ & + \frac{a_{2,l}}{(M+N)(y_4+a_{1,l})^2} \left[\frac{\tilde{K}(y_4)}{y_4^{2N-4}} + y_4^2 B(y_4) \right]. \end{aligned}$$

The coefficient of $a_{2,l}$ in the expression of $\sum_{l=2}^{N-1} -a_{1,l} \Psi_l(y_4)$ is given by

$$-c a_{1,l} \frac{\tilde{K}(y_4)}{(y_4 + a_{1,l})^2 y_4^{2N-4}}$$

where $c = \frac{2M+2N+1}{(M+N)^2}$. Thus, the coefficient of $a_{2,l}$ in $Y_{0,0}^{a,j}$ is equal to $(-a_{1,l})^j R_{0,1}^l(p)$ added to the coefficient of $\frac{1}{y_4^{j-1}}$ in the previous expression. We can easily check that it is given by

$$\left(\frac{1}{M+N} + c(2N-2-j) \right) \frac{(-1)^j \tilde{K}(-a_{1,l})}{a_{1,l}^{2N-2-j}} - c \frac{(-1)^j}{a_{1,l}^{2N-2-j}} \sum_{i=0}^{N-1} (-1)^i i a_{1,l}^i k_i$$

where the complex numbers k_i are such that $\tilde{K}(y_4) = \sum_{i=0}^{N-1} k_i y_4^i$. Similarly, we can show that if we consider the functions $Y_{0,0}^{a,j}$ as linear functions of the $N-2$ variables $a_{2,l}$, where $2 \leq l \leq N-1$, then their determinant is not the zero function. Hence, they are algebraically independent. Finally, it is clear that considering the functions $X_{0,0}^{a,0}$, $X_{0,0}^{b,i}$ and $Y_{0,0}^{a,j}$ where $1 \leq i \leq M-2$ and $0 \leq j \leq N-3$ as linear functions of $1, a_{2,l}$ and $b_{2,l'}$ where $2 \leq l \leq N-1$ and $1 \leq l' \leq M-2$, we can deduce that they are algebraically independent. \square

4. The dimension of the generic strata.

The dimension τ of the generic strata of the local moduli space of curves corresponds to the codimension of the distribution \mathcal{C} at a generic point of M . According to proposition 3.2, the family of coefficients $\{X_{0,0}^{a,0}, X_{0,0}^{b,i}, Y_{0,0}^{a,j}\}_{\substack{i=1,\dots,M-2 \\ j=0,\dots,N-3}}$ of $X_{0,0}$ is functionally independent: thus, any family of r vector fields in dimension r whose coefficients are chosen among $\{X_{0,0}^{a,0}, X_{0,0}^{b,i}, Y_{0,0}^{a,j}\}_{\substack{i=1,\dots,M-2 \\ j=0,\dots,N-3}}$ is generically free: indeed, their determinant cannot identically vanish since it would produce a functional relation between $\{X_{0,0}^{a,0}, X_{0,0}^{b,i}, Y_{0,0}^{a,j}\}_{\substack{i=1,\dots,M-2 \\ j=0,\dots,N-3}}$. Thus, to compute the dimension of the generic strata, we just have to browse the region of moduli and to compute at each level how many moduli can actually be reached by the vector fields $X_{m,n}$. For the following considerations, we recommend to refer at each step to Example 3 in section 5.

From now on, we denote by l the levels of the region of moduli in correspondence with the decomposition of the set \mathcal{P} introduced before. In fact, for $1 \leq l_b \leq N - 1$, it implies that it is the level formed by $l_a = l_b$ of the subspace \mathcal{P}_a and l_b of the subspace \mathcal{P}_b , and for $N \leq l_b \leq N + 2M - 5$, it is just the level formed by l_b . The previous proposition shows that the first level at which the vector field $X_{0,0}$ starts action is $l = 1$. We note that we say a vector field $X_{m,n}$ starts action at a level l if there is at least one non zero coefficient in its decomposition on this level and all the coefficients in its decomposition on the previous levels are zero. The main purpose of this section is to show:

Lemma 4.1. *If $M, N > 2$, then the vector space generated by the vector fields $X_{m,n}$ which act at*

the level $l = 1, \dots, N + 2M - 5$ admits as a basis:

$$\left\{ \begin{array}{ll} l = 1 & \{X_{0,0}\} \\ l = 2 & \{X_{1,0}\} \\ l = 3 & \{X_{2,0}, X_{0,1}\} \\ 4 \leq l \leq \left\lfloor \frac{N}{2} \right\rfloor + 1 & \{X_{l-1,0}, X_{l-3,1}, X_{0,l-2}, \dots, X_{l-4,2}\} \\ l = \left\lfloor \frac{N}{2} \right\rfloor + 2 & \{X_{l-1,0}, X_{l-3,1}, X_{0,l-2}, \dots, X_{N-l-2,2l-N}\} \\ l = \frac{N}{2} + 3 + i, \quad 0 \leq i \leq \frac{N}{2} - 5, & \{X_{l-1,0}, X_{l-3,1}, X_{0,l-2}, \dots, X_{N-l-2,2l-N}, \\ & \quad N \text{ even} \quad X_{\frac{N}{2}-2+i,2}, X_{\frac{N}{2}-4+i,3}, \dots, X_{\frac{N}{2}+i-2m_1,m_1+1}\} \\ l = \frac{N+1}{2} + 2 + i, \quad 0 \leq i \leq \frac{N+1}{2} - 5, & \{X_{l-1,0}, X_{l-3,1}, X_{0,l-2}, \dots, X_{N-l-2,2l-N}, \\ & \quad N \text{ odd} \quad X_{\frac{N-1}{2}-2+i,2}, X_{\frac{N-1}{2}-4+i,3}, \dots, X_{\frac{N-1}{2}+i-2m_2,m_2+1}\} \\ l = N - 1 & \{X_{l-1,0}, X_{l-3,1}, X_{N-6,2}, X_{N-8,3}, \dots, \\ & \quad X_{N-4-2\min(\lfloor \frac{N-7}{3} \rfloor + 1, M-3), \min(\lfloor \frac{N-7}{3} \rfloor + 1, M-3)+1}\} \\ l = N & \{X_{l-3,1}, X_{N-5,2}, X_{N-7,3}, \dots, \\ & \quad X_{N-3-2\min(\lfloor \frac{N-5}{3} \rfloor + 1, M-3), \min(\lfloor \frac{N-5}{3} \rfloor + 1, M-3)+1}\} \\ l = N + 1 + r, \quad 0 \leq r \leq N - 4 & \{X_{N-3, \frac{r+1}{2}+1}, X_{N-5, \frac{r+1}{2}+2}, \dots, X_{N+r-2n_1, n_1}, \\ & \quad r \text{ odd} \quad X_{N-1+r,0}, X_{N-3+r,1}, \dots, X_{N, \frac{r-1}{2}}\}^* \\ l = N + 1 + r, \quad 0 \leq r \leq N - 4, & \{X_{N-2, \frac{r}{2}+1}, X_{N-4, \frac{r}{2}+2}, \dots, X_{N+r-2n_2+2, n_2-1}, \\ & \quad r \text{ even} \quad X_{N-1+r,0}, X_{N-3+r,1}, \dots, X_{N-1, \frac{r}{2}}\}^* \\ l = N + 1 + r, \quad N - 3 \leq r \leq 2M - 6, & \{X_{N-3, \frac{r+1}{2}+1}, X_{N-5, \frac{r+1}{2}+2}, \dots, X_{N+r-2n_3, n_3}, \\ & \quad r \text{ odd} \quad X_{N-1+r,0}, X_{N-3+r,1}, \dots, X_{N, \frac{r-1}{2}}\}^* \\ l = N + 1 + r, \quad N - 3 \leq r \leq 2M - 6, & \{X_{N-2, \frac{r}{2}+1}, X_{N-4, \frac{r}{2}+2}, \dots, X_{N+r-2n_4+2, n_4-1}, \\ & \quad r \text{ even} \quad X_{N-1+r,0}, X_{N-3+r,1}, \dots, X_{N-1, \frac{r}{2}}\}^* \end{array} \right.$$

where $m_1 = \min(\lfloor \frac{2i+1}{3} \rfloor + 1, M - 3)$, $m_2 = \min(\lfloor \frac{2i}{3} \rfloor + 1, M - 3)$, $n_1 = \lfloor \frac{N-3+2r}{3} \rfloor + 2$, $n_2 = \lfloor \frac{N-3+2r}{3} \rfloor + 3$, $n_3 = \lfloor \frac{r-N+4}{2} \rfloor + N - 2$ and $n_4 = \lfloor \frac{r-N+4}{2} \rfloor + N - 1$. The asterisk (*) means that this family is a basis if its cardinal is less than or equal to q_l , otherwise, any subfamily of cardinal q_l form a basis.

Since $X_{0,0}^{a,0}$ is a non zero coefficient among the coefficients $\{X_{0,0}^{a,j}\}$ in the decomposition of $X_{0,0}$, the vector fields $X_{m,0}$ may start action on the subspace \mathcal{P}_a . The first level of the subspace \mathcal{P}_a at which $X_{m,0}$ may have an action is $l_a = m + 1$ and that of the subspace \mathcal{P}_b is $l_b = m + 2$: this is because $X_{m,0} = x^m X_{0,0} = x_4^m y_4^m X_{0,0}$ and the levels of the subspace \mathcal{P}_a are determined by the powers of x_4 and those of the subspace \mathcal{P}_b are determined by the powers of y_4 and since $X_{m,0} = x^m X_{0,0}$, its projection on the previous levels vanish. For $1 \leq l_b \leq N - 1$, $l_a = l_b$, the vector fields $X_{m,0}$ can be used to kill only one modulus at each level $l_a = m + 1$ of the subspace \mathcal{P}_a . For $N \leq l_b \leq N + 2M - 5$, the monomial term having $X_{0,0}^{a,0}$ as a coefficient in the decomposition of $X_{m,0}$ is outside the region of moduli (at these levels we are outside the subspace \mathcal{P}_a) and so we will see that the vector field $X_{m,0}$ acts only on the subspace \mathcal{P}_b starting precisely at the level $l_b = m + 2$.

The vector fields $X_{m,1}$ may start action on the subspaces \mathcal{P}_a and \mathcal{P}_b . The first level of the subspace \mathcal{P}_a at which $X_{m,1}$ may have an action is $l_a = m + 3$ and that of the subspace \mathcal{P}_b is $l_b = m + 3$ as well. If $M = 2$, then there are no moduli in the region associated to the subspace \mathcal{P}_b , and so we can use the vector field $X_{m,1}$ to kill one modulus at each level $l_a = m + 3$ of the subspace \mathcal{P}_a . If

$M > 2$, then for $3 \leq l_b \leq N + 1$, $l_a = l_b$, the vector fields $X_{m,1}$ can be used to kill one modulus at each level $l_b = m + 3$ of the subspace \mathcal{P}_b . For $N + 2 \leq l_b \leq N + 2M - 5$, the monomial term having $X_{0,0}^{a,0}$ as a coefficient in the decomposition of $X_{m,1}$ is outside the region of moduli, and so we will see that this vector field acts only on the subspace \mathcal{P}_b starting precisely at the level $l_b = m + 4$.

For $n \neq 0, 1$, the vector fields $X_{m,n}$ may start action on the subspace \mathcal{P}_a . The first level of the subspace \mathcal{P}_a at which $X_{m,n}$ may have an action is $l_a = m + n + 2$ and that of the subspace \mathcal{P}_b is $l_b = m + 2n + 1$ which is strictly greater than $m + n + 2$ as $n \geq 2$: in fact, $X_{m,n} = x^m y^n X_{0,0} = x_4^{m+n} y_4^{m+2n} X_{0,0}$ and the levels of the subspace \mathcal{P}_a are determined by the powers of x_4 and those of the subspace \mathcal{P}_b are determined by the powers of y_4 . For $l_a \geq 4$, $X_{m,n}$ can be used to kill a modulus which is exactly at the level $l_a = m + n + 2$ of the subspace \mathcal{P}_a . However, once all the moduli at a certain level are killed, the extra vector fields acting at this level can be used to kill moduli at the level $l_b = m + 2n + 1$ of the subspace \mathcal{P}_b if the monomial term having $X_{0,0}^{a,0}$ as a coefficient in the decomposition of $X_{m,n}$ is inside the region of moduli. Otherwise, if it is outside the region of moduli, then either the extra vector fields $X_{m,n}$ do not act at the level $l_b = m + 2n + 1$ but act and can be used to kill moduli at the level $l_b = m + 2n + 2$ of the subspace \mathcal{P}_b , or they actually act at the level $l_b = m + 2n + 1$ of the subspace \mathcal{P}_b but all the moduli at this level and the next levels are killed. This also works for the extra vector fields acting at the higher levels of the subspace \mathcal{P}_a .

Based on that, we denote by $\nu_{m,n} + 1 = m + 2n + 1$ the first level of the subspace \mathcal{P}_b at which a vector field $X_{m,n}$ may have an action.

We note that if $M > 2$, then killing moduli on the subspace \mathcal{P}_b always starts at the level $l_b = 3$ and this is because we use $X_{0,0}$ to kill a modulus at the first level of the subspace \mathcal{P}_a and $X_{1,0}$ to kill a modulus at the second level (if it exists, i.e. $N > 2$), so $X_{0,1}$ will be used at the third level of the subspace \mathcal{P}_b (if $N = 2$ then both $X_{1,0}$ and $X_{0,1}$ will be used at the third level of the subspace \mathcal{P}_b).

Using the equations of the edges of the region of moduli, we find that the monomial term having $X_{0,0}^{a,0}$ as a coefficient in the decomposition of $X_{m,n}$, which is $x_4^{m+n} y_4^{m+2n}$, is inside the region of moduli when m and n satisfy the following inequalities

$$\begin{cases} n + 1 & \leq M - 1 \\ m + 1 & \leq N - 1. \end{cases}$$

The vector fields $X_{m,n}$ such that $m \geq N - 1$ and $n \neq 0$ do not actually act at the level $\nu_{m,n} + 1$ of the subspace \mathcal{P}_b . The following lemma shows that they act at the next level. We note that they do not even act on the subspace \mathcal{P}_a .

Lemma 4.2. *For a fixed integer d , the vector fields $X_{m,n}$ such that $\nu_{m,n} + 1 = d + 1$ and $m \geq N - 1$ act at the level $\nu_{m,n} + 2 = m + 2n + 2 = d + 2$ of the subspace \mathcal{P}_b when there are moduli at this level.*

Proof. If $m \geq N - 1$, then the vector fields $X_{m,n}$ such that $\nu_{m,n} + 1 = d + 1$ do not act at the level $\nu_{m,n} + 1 = N + 1 + i$ where $-1 \leq i \leq 2M - 6$: $X_{m,0}$ does not act at the level $\nu_{m,n} + 1$ of the subspace \mathcal{P}_a and $X_{m,n}$ such that $n \neq 0$ does not act at the level $\nu_{m,n} + 1$ of the subspace \mathcal{P}_b . They are given by

$$\begin{cases} \left\{ X_{N-1+2j, \frac{i+1}{2}-j} \right\}_{0 \leq j \leq \frac{i+1}{2}} & \text{if } i \text{ is odd} \\ \left\{ X_{N+2j, \frac{i}{2}-j} \right\}_{0 \leq j \leq \frac{i}{2}} & \text{if } i \text{ is even.} \end{cases}$$

If $i = -1$, then $X_{N-1,0} = x_4^{N-1} y_4^{N-1} X_{0,0}$ is the only vector field $X_{m,n}$ such that $m \geq N-1$ and $v_{m,n} + 1 = N$ which does not act at the level N of the subspace \mathcal{P}_a (because it does not exist actually): indeed it is the first vector field for which the monomial term having $X_{0,0}^{a,0}$ as a coefficient in its decomposition, which is $x_4^{N-1} y_4^{N-1}$, is outside the region of moduli: it is actually at the edge of equation $(2x_4 - y_4 - (N-1) = 0)$ of the region. Supposing that $M > 2$ (otherwise there are no moduli in the region associated to the subspace \mathcal{P}_b), the coefficient of y_4 in the decomposition of $X_{0,0}$, which is $X_{0,0}^{b,1}$, is different from zero. So, the vector field $X_{N-1,0}$ acts at the level $N+1$ of the subspace \mathcal{P}_b : in its decomposition, $X_{0,0}^{b,1}$ is the coefficient of $x_4^{N-1} y_4^N$ which is the first monomial term inside the region of moduli at the level $N+1$.

If $0 \leq i \leq 2M-6$, such that i is odd, then since $X_{N-1, \frac{i+1}{2}} = y_4^{\frac{i+1}{2}} X_{N-1,0}$, the monomial term having $X_{0,0}^{a,0}$ as a coefficient in the decomposition of $X_{N-1, \frac{i+1}{2}}$ is also at the edge of equation $(2x_4 - y_4 - (N-1) = 0)$ of the region of moduli (as $y = x_4 y_4^2$). Again since $M > 2$, the vector field $X_{N-1, \frac{i+1}{2}}$, which does not act at the level $N+1+i$ of the subspace \mathcal{P}_b , acts at the level $N+1+(i+1)$: also in its decomposition, $X_{0,0}^{b,1}$ is the coefficient of $x_4^{N-1+\frac{i+1}{2}} y_4^{N-1+i+2}$ which is the first monomial term inside the region of moduli at the level $N+1+(i+1)$. Now, for the other vector fields, we have

$$X_{N-1+2j, \frac{i+1}{2}-j} = \frac{x_4^{2j}}{y_4^j} X_{N-1, \frac{i+1}{2}} = x_4^j X_{N-1, \frac{i+1}{2}}.$$

If $j+1 \leq M-2$, then the coefficient of $\frac{y_4}{x_4^j}$ in the decomposition of $X_{0,0}$, which is $X_{0,0}^{b,j+1}$, is different from zero, and so the first monomial term inside the region at the level $N+1+(i+1)$ which is $x_4^{N-1+\frac{i+1}{2}} y_4^{N-1+i+2}$ will have $X_{0,0}^{b,j+1}$ as a coefficient in the decomposition of $X_{N-1+2j, \frac{i+1}{2}-j}$. This means that to show that the vector fields $\{X_{N-1+2j, \frac{i+1}{2}-j}\}_{0 \leq j \leq \frac{i+1}{2}}$ act at the level $N+1+(i+1)$, it is enough to show that we have the following inequality

$$j+1 \leq M-2$$

for $0 \leq j \leq \frac{i+1}{2}$, which ensures the existence of $\frac{y_4}{x_4^j}$ for all $0 \leq j \leq \frac{i+1}{2}$ in the decomposition of $X_{0,0}$. In fact, it is enough to show that these vector fields act at the level $v_{m,n} + 2 = N+1+(i+1) = d+2$ when there are moduli at this level. More precisely, we need to consider the action of the r vector fields $\{X_{N-1+2j, \frac{i+1}{2}-j}\}_{0 \leq j \leq r-1}$ at the level $d+2$ if the number of points at this level is greater than or equal to r i.e. if we have the following inequality $q_{d+2} \geq r$ where $q_{d+2} = \left\lceil \frac{d+N}{2} \right\rceil + M - (d+2)$. It clearly implies that $j+1 \leq M-2$ for all $0 \leq j \leq r-1$.

The case where i is even can be treated similarly. □

If $M > 2$, then the vector fields $X_{m,n}$ such that $n \geq M-1$, which are extra from the region associated to the subspace \mathcal{P}_a , may start action at the level $v_{m,n} + 1$ of the subspace \mathcal{P}_b . In the next lemma, which deals with the generic dimension of the distribution C , we will see that all the moduli at such a level as well as the next levels are killed. Lemma 4.1 is equivalent to:

Lemma 4.3. *If $M > 2$ and $N \geq 6$, then for any $d = 0, \dots, N+2M-6$, the dimension of the vector*

space generated by the vector fields $X_{m,n}$ which act at the level $l = d + 1$ is given by:

$$\left\{ \begin{array}{ll} 1 & \text{if } d = 0, 1 \\ 2 & \text{if } d = 2 \\ 1 + \min(N - d - 1, d - 1) & \text{if } 3 \leq d \leq \left\lfloor \frac{N+2}{2} \right\rfloor \\ N - d + \min\left(M - 3, \left\lfloor \frac{2i+1}{3} \right\rfloor + 1\right) & \text{if } d = \frac{N}{2} + 2 + i \text{ where} \\ & 0 \leq i \leq \frac{N}{2} - 3 \text{ and } N \text{ is even} \\ N - d + \min\left(M - 3, \left\lfloor \frac{2i}{3} \right\rfloor + 1\right) & \text{if } d = \frac{N+1}{2} + 1 + i \text{ where} \\ & 0 \leq i \leq \frac{N+1}{2} - 3 \text{ and } N \text{ is odd} \\ 1 + \min\left(M - 3, \left\lfloor \frac{N-3}{3} \right\rfloor + 2\right) & \text{if } d = N \\ \min\left(q_{N+1+r}, \left\lfloor \frac{N-3+2r}{3} \right\rfloor + \left\lfloor \frac{r}{2} \right\rfloor - \left\lfloor \frac{r-1}{2} \right\rfloor + 2\right) & \text{if } d = N + r \text{ where } 1 \leq r \leq N - 4 \\ \min\left(q_{N+1+r}, N - 2 + \left\lfloor \frac{r-N+4}{2} \right\rfloor + \left\lfloor \frac{r}{2} \right\rfloor - \left\lfloor \frac{r-1}{2} \right\rfloor\right) & \text{if } d = N + r \text{ where} \\ & N - 3 \leq r \leq 2M - 6. \end{array} \right.$$

Proof. It is clear that only $X_{0,0}$ acts at the level $l = 1$ and $X_{1,0}$ acts at the level $l = 2$. The vector fields $X_{2,0}$ and $X_{0,1}$ act at the level $l = 3$ and they are linearly independent. In fact, their decomposition is given by the following invertible matrix

$$\begin{array}{cc} & X_{2,0} \quad X_{0,1} \\ \begin{array}{c} x_4^2 y_4^2 \\ x_4 y_4^2 \end{array} & \begin{pmatrix} X_{0,0}^{a,0} & Y_{0,0}^{a,1} \\ 0 & X_{0,0}^{a,0} \end{pmatrix}. \end{array}$$

For $d \geq 3$, the vector field $X_{m,0}$ such that $m + 1 = d + 1$ acts at the level $l_a = d + 1$ of the subspace \mathcal{P}_a . The vector field $X_{m,1}$ such that $m + 3 = d + 1$ acts at the level $l_b = d + 1$ of the subspace \mathcal{P}_b (it also acts at the level $l_a = d + 1$ of the subspace \mathcal{P}_a but we will consider its action on the subspace \mathcal{P}_b as $M > 2$). The number of vector fields $X_{m,n}$ such that $n \neq 0, 1$ and $m + n + 2 = d + 1$ is equal to $d - 2$ and the number of points at the level $l_a = d + 1$ of the subspace \mathcal{P}_a is equal to $N - d - 1$. If N is even, then the first level of the subspace \mathcal{P}_a having all the moduli killed corresponds to $d = \frac{N}{2}$ and there are no extra vector fields at this level. For $d = \frac{N}{2} + 1$, there are two extra vector fields acting at the level $l_a = d + 1$. Among them, the vector field $X_{m,n}$ with the smallest n is given by $X_{\frac{N}{2}-2,2}$. This vector field acts on the subspace \mathcal{P}_b starting precisely at the level $l_b = \frac{N}{2} + 3$. Thus, if $3 \leq d \leq \frac{N}{2} + 1$, then the dimension of the vector space generated by the vector fields $X_{m,n}$ which act at the level $l = d + 1$ is equal to $1 + \min(N - d - 1, d - 1)$. In fact, if $3 \leq d \leq \frac{N}{2}$, then their decomposition is given by the matrix

$$\begin{array}{c} x_4^d y_4^2 \\ \vdots \\ x_4^d y_4^{d-1} \\ x_4^d y_4^d \\ x_4^{d-1} y_4^d \end{array} \begin{pmatrix} X_{0,d-1} & X_{1,d-2} & \cdots & X_{d-3,2} & X_{d,0} & X_{d-2,1} \\ Y_{0,0}^{a,2d-3} & Y_{0,0}^{a,2d-4} & \cdots & Y_{0,0}^{a,d} & 0 & Y_{0,0}^{a,d-1} \\ \vdots & \vdots & & \vdots & \vdots & \vdots \\ Y_{0,0}^{a,d} & Y_{0,0}^{a,d-1} & \cdots & Y_{0,0}^{a,3} & 0 & Y_{0,0}^{a,2} \\ Y_{0,0}^{a,d-1} & Y_{0,0}^{a,d-2} & \cdots & Y_{0,0}^{a,2} & X_{0,0}^{a,0} & Y_{0,0}^{a,1} \\ 0 & 0 & \cdots & 0 & 0 & X_{0,0}^{a,0} \end{pmatrix}$$

which is clearly invertible. If $d = \frac{N}{2} + 1$ and $d \neq N - 2$, then their decomposition is given by the

matrix

$$\begin{matrix}
x_4^d y_4^{2d-N+2} \\
\vdots \\
x_4^d y_4^{d-1} \\
x_4^d y_4^d \\
x_4^{d-1} y_4^d
\end{matrix}
\begin{pmatrix}
X_{0,d-1} & X_{1,d-2} & \cdots & X_{N-d-3,2d-N+2} & X_{d,0} & X_{d-2,1} \\
Y_{0,0}^{a,N-3} & Y_{0,0}^{a,N-4} & \cdots & Y_{0,0}^{a,d} & 0 & Y_{0,0}^{a,N-d-1} \\
\vdots & \vdots & & \vdots & \vdots & \vdots \\
Y_{0,0}^{a,d} & Y_{0,0}^{a,d-1} & \cdots & Y_{0,0}^{a,2d-N+3} & 0 & Y_{0,0}^{a,2} \\
Y_{0,0}^{a,d-1} & Y_{0,0}^{a,d-2} & \cdots & Y_{0,0}^{a,2d-N+2} & X_{0,0}^{a,0} & Y_{0,0}^{a,1} \\
0 & 0 & \cdots & 0 & 0 & X_{0,0}^{a,0}
\end{pmatrix}$$

which is clearly invertible as well. We note that if $d = \frac{N}{2} + 1 = N - 2$, then the associated matrix is the principle submatrix of the above matrix corresponding to the vector fields $X_{d,0}$ and $X_{d-2,1}$. To know the number of vector fields which act at the level l_b of the subspace \mathcal{P}_b for $\frac{N}{2} + 3 \leq l_b \leq N$, we have to count the extra vector fields acting at the levels $\frac{N}{2} + 2 \leq l_a \leq N - 1$ of the subspace \mathcal{P}_a . For that we write $d = \frac{N}{2} + j$ where $1 \leq j \leq \frac{N}{2} - 2$, and so the number of the extra vector fields acting at the level $l_a = d + 1$ is equal to $2j$. We can easily check that among them the number of those which act at the level $l_b = \frac{N}{2} + 3 + i$ where $0 \leq i \leq \frac{N}{2} - 3$ is equal to $\left\lfloor \frac{2i+1}{3} \right\rfloor + 1$. We note that at the levels $\frac{N}{2} + 3 \leq l_a \leq N$, all the moduli are killed. Thus, if $\frac{N}{2} + 2 \leq d \leq N - 3$, then the decomposition of the vector fields which act at the level $l = d + 1$ is given by the following invertible matrix

$$\begin{matrix}
x_4^d y_4^{2d-N+2} \\
\vdots \\
x_4^d y_4^{d-1} \\
x_4^d y_4^d \\
x_4^{d-1} y_4^d
\end{matrix}
\begin{pmatrix}
X_{0,d-1} & X_{1,d-2} & \cdots & X_{N-d-3,2d-N+2} & X_{d,0} & X_{d-2,1} & X_{\frac{N}{2}-2+i,2} & X_{\frac{N}{2}-4+i,3} & \cdots & X_{\frac{N}{2}+i-2m_1,m_1+1} \\
Y_{0,0}^{a,N-3} & Y_{0,0}^{a,N-4} & \cdots & Y_{0,0}^{a,d} & 0 & Y_{0,0}^{a,N-d-1} & & & & \\
\vdots & \vdots & & \vdots & \vdots & \vdots & & & & \\
Y_{0,0}^{a,d} & Y_{0,0}^{a,d-1} & \cdots & Y_{0,0}^{a,2d-N+3} & 0 & Y_{0,0}^{a,2} & & & * & \\
Y_{0,0}^{a,d-1} & Y_{0,0}^{a,d-2} & \cdots & Y_{0,0}^{a,2d-N+2} & X_{0,0}^{a,0} & Y_{0,0}^{a,1} & & & & \\
0 & 0 & \cdots & 0 & 0 & X_{0,0}^{a,0} & & & & \\
\hline
& & & & & & X_{0,0}^{a,0} & & & * \\
& & & & & & & X_{0,0}^{a,0} & & \\
& & & & & & & & \ddots & \\
& & & 0 & & & & & & X_{0,0}^{a,0}
\end{pmatrix},$$

where $m_1 = \min\left(\left\lfloor \frac{2i+1}{3} \right\rfloor + 1, M - 3\right)$. If $d = N - 2$ (respectively $d = N - 1$), then their decomposition is given by a matrix of the above form such that the first block matrix reduces to its principle submatrix corresponding to the vector fields $X_{d,0}$ and $X_{d-2,1}$ (respectively $X_{d-2,1}$).

Now, for $d = N - 1$, the number of vector fields $X_{m,n}$ such that $n \neq 0, 1$ and $m + n + 2 = d + 1$ is equal to $d - 2 = N - 3$. Actually, if we write d as before i.e. $d = \frac{N}{2} + j$ with $j = \frac{N}{2} - 1$, then this number is not equal to $2j = N - 2$. The vector field among them having the greatest n is given by $X_{0,N-2}$. Since this vector field starts action at the level $l_b = 2N - 3$ of the subspace \mathcal{P}_b , then we can not use the previous formula to find the number of vector fields which act at the levels $l_b \geq 2N - 2$ of the subspace \mathcal{P}_b . If we write $d = 2N - 3 + j$ where $0 \leq j \leq 2M - N - 3$, we can easily check that among them the number of those which act at the level $l_b = d + 1$ is equal to $N - 3 + \left\lfloor \frac{j+1}{2} \right\rfloor$. For the levels $l_b = d + 1 = N + 1 + r$ where $0 \leq r \leq 2M - 6$, we know from lemma 4.2 that among the vector fields $X_{m,n}$ such that $n \neq 0, 1$ and $m + 2n + 1 = d + 1$, there are $\left\lfloor \frac{r-1}{2} \right\rfloor$ vector fields such that $m \geq N - 1$ which do not act at the level $l_b = d + 1$. They are given by the family

$$\begin{cases}
\left\{ X_{d-4,2}, \dots, X_{N-1, \frac{r+1}{2}} \right\} & \text{if } r \geq 3 \text{ is odd} \\
\left\{ X_{d-4,2}, \dots, X_{N, \frac{r}{2}} \right\} & \text{if } r \geq 4 \text{ is even} .
\end{cases}$$

However, we also know from lemma 4.2, that at the previous level $l_b = d_{r-1} + 1$ where $d_{r-1} = N + (r - 1)$, there are $\left\lfloor \frac{r}{2} \right\rfloor + 1$ vector fields $X_{m,n}$ such that $m + 2n + 1 = d_{r-1} + 1$ which do not act at the level $l_b = d_{r-1} + 1$ because $m \geq N - 1$ but act at the level $l_b = d_r + 1$ where $d_r = N + r$. They are given by the family

$$\begin{cases} \{X_{N-1+r,0}, \dots, X_{N, \frac{r-1}{2}}\} & \text{if } r \text{ is odd} \\ \{X_{N-1+r,0}, \dots, X_{N-1, \frac{r}{2}}\} & \text{if } r \text{ is even.} \end{cases}$$

We note that the vector fields $X_{m,n}$ such that $m \geq N - 1$ do not act on the subspace \mathcal{P}_a . Thus, if $0 \leq r \leq N - 4$ and r is odd, then if the number of the vector fields which act at the level $l_b = N + 1 + r$, which is equal to $n_1 = \left\lfloor \frac{N-3+2r}{3} \right\rfloor + 2$, is less than or equal to the number of points at this level, then their decomposition is given by the matrix

$$\begin{array}{c} X_{N-3, \frac{r+1}{2}+1} \quad X_{N-5, \frac{r+1}{2}+2} \quad \dots \quad X_{N+r-2n_1, n_1} \quad X_{N-1+r,0} \quad X_{N-3+r,1} \quad \dots \quad X_{N, \frac{r-1}{2}} \\ \begin{array}{c} X_4^{N+\frac{r+1}{2}-2} y_4^{N+r} \\ X_4^{N+\frac{r+1}{2}-3} y_4^{N+r} \\ \vdots \\ X_4^{N+r-n_1} y_4^{N+r} \\ X_4^{N+r-n_1-1} y_4^{N+r} \\ \vdots \\ X_4^{N+\frac{r+1}{2}-n_1-1} y_4^{N+r} \end{array} \end{array} \left(\begin{array}{c|ccc} X_{0,0}^{a,0} & & * & \\ & X_{0,0}^{a,0} & & \\ & & \ddots & \\ 0 & & & X_{0,0}^{a,0} \\ \hline & & & 0 \\ & & & 0 \end{array} \left| \begin{array}{ccc} X_{0,0}^{b, \frac{r-1}{2}+2} & X_{0,0}^{b, \frac{r-1}{2}+1} & \dots & X_{0,0}^{b,2} \\ X_{0,0}^{b, \frac{r-1}{2}+3} & X_{0,0}^{b, \frac{r-1}{2}+2} & \dots & X_{0,0}^{b,3} \\ \vdots & \vdots & & \vdots \\ X_{0,0}^{b, n_1} & X_{0,0}^{b, n_1-1} & \dots & X_{0,0}^{b, n_1 - \frac{r-1}{2}} \\ X_{0,0}^{b, n_1+1} & X_{0,0}^{b, n_1} & \dots & X_{0,0}^{b, n_1 - \frac{r-3}{2}} \\ \vdots & \vdots & & \vdots \\ X_{0,0}^{b, n_1 + \frac{r+1}{2}} & X_{0,0}^{b, n_1 + \frac{r-1}{2}} & \dots & X_{0,0}^{b, n_1+1} \end{array} \right) \cdot$$

We note that having vector fields less than the number of points at that level is equivalent to having the following inequality

$$n_1 \leq M - 2 - \frac{r+1}{2}.$$

This ensures that all the entries $X_{0,0}^{b,j}$ in the last block matrix of the above matrix satisfy $j \leq M - 2$ and so they are different from zero. Otherwise, if their number is greater than the number of the points at that level, then their decomposition is given by a principal sub-matrix of size q_{N+1+r} of the above matrix. So, it is invertible.

Similarly, if $0 \leq r \leq N - 4$ and r is even, then if the number of the vector fields which act at the level $l_b = N + 1 + r$, which is equal to $n_2 = \left\lfloor \frac{N-3+2r}{3} \right\rfloor + 3$, is less than or equal to the number of points at this level, then their decomposition is given by the matrix

$$\begin{array}{c} X_{N-2, \frac{r}{2}+1} \quad X_{N-4, \frac{r}{2}+2} \quad \dots \quad X_{N+r-2n_2+2, n_2-1} \quad X_{N-1+r,0} \quad X_{N-3+r,1} \quad \dots \quad X_{N-1, \frac{r}{2}} \\ \begin{array}{c} X_4^{N+\frac{r}{2}-1} y_4^{N+r} \\ X_4^{N+\frac{r}{2}-2} y_4^{N+r} \\ \vdots \\ X_4^{N+r-n_2+1} y_4^{N+r} \\ X_4^{N+r-n_2} y_4^{N+r} \\ \vdots \\ X_4^{N+\frac{r}{2}-n_2} y_4^{N+r} \end{array} \end{array} \left(\begin{array}{c|ccc} X_{0,0}^{a,0} & & * & \\ & X_{0,0}^{a,0} & & \\ & & \ddots & \\ 0 & & & X_{0,0}^{a,0} \\ \hline & & & 0 \\ & & & 0 \end{array} \left| \begin{array}{ccc} X_{0,0}^{b, \frac{r}{2}+1} & X_{0,0}^{b, \frac{r}{2}} & \dots & X_{0,0}^{b,1} \\ X_{0,0}^{b, \frac{r}{2}+2} & X_{0,0}^{b, \frac{r}{2}+1} & \dots & X_{0,0}^{b,2} \\ \vdots & \vdots & & \vdots \\ X_{0,0}^{b, n_2-1} & X_{0,0}^{b, n_2-2} & \dots & X_{0,0}^{b, n_2 - \frac{r}{2} - 1} \\ X_{0,0}^{b, n_2} & X_{0,0}^{b, n_2-1} & \dots & X_{0,0}^{b, n_2 - \frac{r}{2}} \\ \vdots & \vdots & & \vdots \\ X_{0,0}^{b, n_2 + \frac{r}{2}} & X_{0,0}^{b, n_2 + \frac{r}{2} - 1} & \dots & X_{0,0}^{b, n_2} \end{array} \right) \cdot$$

Having vector fields less than the number of points at that level is equivalent to having the following inequality

$$n_2 \leq M - 2 - \frac{r}{2}.$$

This ensures that all the entries $X_{0,0}^{b,j}$ in the last block matrix of the above matrix satisfy $j \leq M - 2$ and so they are different from zero.

Now, if $N - 3 \leq r \leq 2M - 6$ and r is odd, then the number of the vector fields which act at the level $l_b = N + 1 + r$ is equal to $n_3 = \left\lfloor \frac{r-N+4}{2} \right\rfloor + N - 2$. If this number is less than or equal to the number of points at this level, then their decomposition is given by the matrix

$$\begin{array}{c}
X_4^{N+\frac{r+1}{2}-2} y_4^{N+r} \\
X_4^{N+\frac{r+1}{2}-3} y_4^{N+r} \\
\vdots \\
X_4^{n_3+1} y_4^{N+r} \\
\hline
X_4^{n_3} y_4^{N+r} \\
\vdots \\
X_4^{\frac{N}{2}} y_4^{N+r}
\end{array}
\begin{pmatrix}
X_{N-3, \frac{r+1}{2}+1} & X_{N-5, \frac{r+1}{2}+2} & \cdots & X_{N+r-2n_3, n_3} & X_{N-1+r, 0} & X_{N-3+r, 1} & \cdots & X_{N, \frac{r-1}{2}} \\
X_{0,0}^{a,0} & & & * & X_{0,0}^{b, \frac{r-1}{2}+2} & X_{0,0}^{b, \frac{r-1}{2}+1} & \cdots & X_{0,0}^{b, 2} \\
& X_{0,0}^{a,0} & & & X_{0,0}^{b, \frac{r-1}{2}+3} & X_{0,0}^{b, \frac{r-1}{2}+2} & \cdots & X_{0,0}^{b, 3} \\
& & \ddots & & \vdots & \vdots & & \vdots \\
0 & & & X_{0,0}^{a,0} & X_{0,0}^{b, n_3} & X_{0,0}^{b, n_3-1} & \cdots & X_{0,0}^{b, \frac{N}{2}} \\
\hline
& & & 0 & X_{0,0}^{b, n_3+1} & X_{0,0}^{b, n_3} & \cdots & X_{0,0}^{b, \frac{N}{2}+1} \\
& & & & \vdots & \vdots & & \vdots \\
& & & & X_{0,0}^{b, \frac{N}{2}+r} & X_{0,0}^{b, \frac{N}{2}+r-1} & \cdots & X_{0,0}^{b, \frac{N}{2}+1}
\end{pmatrix}.$$

which is invertible for the same previous reason.

If $N - 3 \leq r \leq 2M - 6$ and r is even, then the number of the vector fields which act at the level $l_b = N + 1 + r$ is equal to $n_4 = \left\lfloor \frac{r-N+4}{2} \right\rfloor + N - 1$. Similarly, if this number is less than or equal to the number of points at this level, then their decomposition is given by the following invertible matrix

$$\begin{array}{c}
X_4^{N+\frac{r}{2}-1} y_4^{N+r} \\
X_4^{N+\frac{r}{2}-2} y_4^{N+r} \\
\vdots \\
X_4^{n_4-1} y_4^{N+r} \\
\hline
X_4^{n_4-2} y_4^{N+r} \\
\vdots \\
X_4^{\frac{N}{2}-1} y_4^{N+r}
\end{array}
\begin{pmatrix}
X_{N-2, \frac{r}{2}+1} & X_{N-4, \frac{r}{2}+2} & \cdots & X_{N+r-2n_4+2, n_4-1} & X_{N-1+r, 0} & X_{N-3+r, 1} & \cdots & X_{N-1, \frac{r}{2}} \\
X_{0,0}^{a,0} & & & * & X_{0,0}^{b, \frac{r}{2}+1} & X_{0,0}^{b, \frac{r}{2}} & \cdots & X_{0,0}^{b, 1} \\
& X_{0,0}^{a,0} & & & X_{0,0}^{b, \frac{r}{2}+2} & X_{0,0}^{b, \frac{r}{2}+1} & \cdots & X_{0,0}^{b, 2} \\
& & \ddots & & \vdots & \vdots & & \vdots \\
0 & & & X_{0,0}^{a,0} & X_{0,0}^{b, n_4-1} & X_{0,0}^{b, n_4-2} & \cdots & X_{0,0}^{b, \frac{N}{2}} \\
\hline
& & & 0 & X_{0,0}^{b, n_4} & X_{0,0}^{b, n_4-1} & \cdots & X_{0,0}^{b, \frac{N}{2}+1} \\
& & & & \vdots & \vdots & & \vdots \\
& & & & X_{0,0}^{b, \frac{N}{2}+r+1} & X_{0,0}^{b, \frac{N}{2}+r} & \cdots & X_{0,0}^{b, n_4}
\end{pmatrix}.$$

We note that if M is odd, then the number of the extra vector fields acting at the level $l_a = d + 1$, where $d = \frac{N}{2} + j$ and $1 \leq j \leq \frac{N}{2} - 2$, is greater than or equal to the number of the remaining points at the horizontal line of equation $(y_4 = d)$ of the subspace \mathcal{P}_b if $j \geq \frac{M-3}{2}$. This means that at the levels $l_b \geq \frac{N+3M-1}{2} - 3$, all the moduli are killed. The vector fields $X_{m,n}$ such that $n \geq M - 1$, which act at the level $l_a = m + n + 2$ but extra, satisfy the inequality $m + n \geq \frac{M+N-3}{2}$. Thus, they may start action at the level $l_b \geq \frac{N+3M-3}{2}$ where all the moduli are killed. The number of the vector fields $X_{m,n}$ such that $m + n + 2 = N + s$, where $s \geq 0$, is greater than or equal to the number of points at the horizontal line of equation $(y_4 = N - 1 + s)$ of the subspace \mathcal{P}_b if $N - 1 + s \geq M - 2$, so at the levels $l_b \geq N + M - 4$, all the moduli are killed. The vector fields $X_{m,n}$ such that $m + n + 2 = N + s$ and $n \geq M - 1$, where $s \geq 0$, may start action at the levels $l_b \geq M + N - 2$ where all the moduli are killed. A similar argument works if M is even.

The next part of the proof is devoted to the case where N is odd. If N is odd, then the first level of the subspace \mathcal{P}_a having all the moduli killed corresponds to $d = \frac{N+1}{2}$ and there is one extra vector fields at this level. We can choose the vector field $X_{m,n}$ with the smallest n which is given by $X_{\frac{N+1}{2}-3, 2}$. This vector field acts on the subspace \mathcal{P}_b starting precisely at the level $l_b = \frac{N+1}{2} + 2$. Thus, if $3 \leq d \leq \frac{N+1}{2}$, then the dimension of the vector space generated by the vector fields $X_{m,n}$ which act at the level $l = d + 1$ is equal to $1 + \min(N - d - 1, d - 1)$.

As in the case where N is even, to know the number of vector fields which act at the level l_b of the subspace \mathcal{P}_b for $\frac{N+1}{2} + 2 \leq l_b \leq N$, we have to count the extra vector fields acting at the levels

$\frac{N+1}{2} + 1 \leq l_a \leq N-1$ of the subspace \mathcal{P}_a . For that we write $d = \frac{N+1}{2} + j$ where $0 \leq j \leq \frac{N+1}{2} - 3$, and so the number of the extra vector fields acting at the level $l_a = d + 1$ is equal to $2j + 1$. Similarly, we can check that among them the number of those which act at the level $l_b = \frac{N+1}{2} + 2 + i$ where $0 \leq i \leq \frac{N+1}{2} - 3$ is equal to $\left\lceil \frac{2i}{3} \right\rceil + 1$. Also, we note that at the levels $\frac{N+1}{2} + 2 \leq l_a \leq N$, all the moduli are killed.

Now, for $d = N - 1$, the number of vector fields $X_{m,n}$ such that $n \neq 0, 1$ and $m + n + 2 = d + 1$ is equal to $d - 2 = N - 3$. If we write d as before i.e. $d = \frac{N+1}{2} + j$ with $j = \frac{N+1}{2} - 2$, then this number is not equal to $2j + 1 = N - 2$. The vector field among them having the greatest n is given by $X_{0, N-2}$. Since this vector field starts action at the level $l_b = 2N - 3$ of the subspace \mathcal{P}_b , then we can not use the previous formula to find the number of vector fields which act at the levels $l_b \geq 2N - 2$ of the subspace \mathcal{P}_b . Similarly, if we write $d = 2N - 3 + j$ where $0 \leq j \leq 2M - N - 3$, we can easily check that among them the number of those which act at the level $l_b = d + 1$ is equal to $N - 3 + \left\lceil \frac{j+1}{2} \right\rceil$. Thus, for the levels $N + 1 \leq l_b \leq 2M + N - 5$, the same argument as the case where N is even works. \square

Remark. If $M > 2$ and $N \leq 5$, then for any $d = 0, \dots, N + 2M - 6$, the dimension of the vector space generated by the vector fields $X_{m,n}$ which act at the level $l = d + 1$ is given by:

1. $N = 5$

$$\begin{cases} 1 & \text{if } d = 0, 1 \\ 2 & \text{if } d = 2, 3 \\ 1 + \min(1, M - 3) & \text{if } d = 4 \\ 1 + \min(2, M - 3) & \text{if } d = 5 \\ \min(3, M - 3) & \text{if } d = 6 \\ \min\left(q_{r+6}, \left\lceil \frac{r}{2} \right\rceil + 3\right) & \text{if } d = r + 5 \text{ where } 2 \leq r \leq 2M - 6. \end{cases}$$

2. $N = 4$

$$\begin{cases} 1 & \text{if } d = 0, 1, 3 \\ 2 & \text{if } d = 2 \\ 1 + \min(2, M - 3) & \text{if } d = 4 \\ \min\left(q_{r+5}, 2\left\lceil \frac{r}{2} \right\rceil - \left\lceil \frac{r-1}{2} \right\rceil + 2\right) & \text{if } d = r + 4 \text{ where } 1 \leq r \leq 2M - 6. \end{cases}$$

3. $N = 3$

$$\begin{cases} 1 & \text{if } d = 0, 1, 2 \\ 1 + \min(1, M - 3) & \text{if } d = 3 \\ \min\left(q_{r+4}, r - \left\lceil \frac{r-1}{2} \right\rceil + 1\right) & \text{if } d = r + 3 \text{ where } 1 \leq r \leq 2M - 6. \end{cases}$$

4. $N = 2$

$$\begin{cases} 1 & \text{if } d = 0 \\ 0 & \text{if } d = 1 \\ 1 + \min(1, M - 3) & \text{if } d = 2 \\ \min\left(q_{r+3}, 2\left\lceil \frac{r}{2} \right\rceil - \left\lceil \frac{r-1}{2} \right\rceil + 1\right) & \text{if } d = r + 2 \text{ where } 1 \leq r \leq 2M - 6. \end{cases}$$

We note that we can easily check that if the number of the vector fields acting at some level is less than that at the previous level by one (which is the only possible case and it is only possible if $l_b \geq N + 1$), then the number of points at this level is less than the number points at the previous level by one. So, we do not need to consider the vector fields, which are extra at some level, at the next level.

If we let

$$\begin{aligned} \tau_0 = & \sum_{r=0}^{N-4} q_{N+1+r} - \left(\left\lfloor \frac{N-3+2r}{3} \right\rfloor + \left\lfloor \frac{r}{2} \right\rfloor - \left\lfloor \frac{r-1}{2} \right\rfloor + 2 \right) \\ & + \sum_{r=N-3}^{2M-6} q_{N+1+r} - \left(N-2 + \left\lfloor \frac{r-N+4}{2} \right\rfloor + \left\lfloor \frac{r}{2} \right\rfloor - \left\lfloor \frac{r-1}{2} \right\rfloor \right), \end{aligned}$$

where exceptionally $q_{N+1} = M-3$, then the previous lemma implies that we have the following:

Theorem A. *The dimension of the generic strata of the moduli space for curves is given by*

1. if $M, N \neq 2$ and N is even:

$$\begin{aligned} \tau_{M,N} = & \tau_0 + 3N - 7 + (M-3) \left(\frac{N}{2} + 2 \right) + \frac{(N-4)(N-6)}{4} \\ & + \sum_{\substack{i=0 \\ \lfloor \frac{2i+1}{3} \rfloor + 1 \leq M-3}}^{\frac{N}{2}-3} \left(M-4 - \left\lfloor \frac{2i+1}{3} \right\rfloor \right) \end{aligned}$$

2. if $M, N \neq 2$ and $N \neq 3$ is odd:

$$\begin{aligned} \tau_{M,N} = & \tau_0 + 3N - 7 + (M-3) \left(\frac{N-1}{2} + 2 \right) + \frac{(N-5)^2}{4} \\ & + \sum_{\substack{i=0 \\ \lfloor \frac{2i}{3} \rfloor + 1 \leq M-3}}^{\frac{N+1}{2}-3} \left(M-4 - \left\lfloor \frac{2i}{3} \right\rfloor \right) \end{aligned}$$

3. if $N = 3, M \neq 2$:

$$\tau_{M,N} = q_4 + 3M + 3N - 17 + \sum_{r=1}^{2M-6} \left(q_{r+4} - \left\lfloor \frac{r}{2} \right\rfloor - 2 \right)$$

4. if $M = 2, N \neq 2$:

$$\tau_{M,N} = 2N - 5 + \sum_{d=2}^{\lfloor \frac{N-1}{2} \rfloor} (N - 2d - 1)$$

5. if $N = 2$:

$$\tau_{M,N} = 2(M-2) + \sum_{\substack{r=0 \\ q_{r+3} \geq \lfloor \frac{r+2}{2} \rfloor + \lfloor \frac{r}{2} \rfloor - \lfloor \frac{r-1}{2} \rfloor}}^{2M-6} q_{r+3} - \left(\left\lfloor \frac{r+2}{2} \right\rfloor + \left\lfloor \frac{r}{2} \right\rfloor - \left\lfloor \frac{r-1}{2} \right\rfloor \right).$$

5. Examples.

In this section, we present some explicit examples.

Example 1. For $N = 3$, $M = 2$, we have $\tau_{2,3} = 1$. In fact, the region of moduli $Q_{M,N}$ is given by

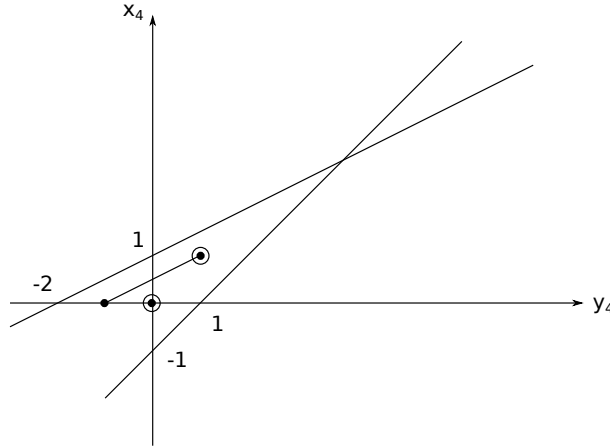

Figure 4: The region $Q_{M,N}$ for $N = 3$, $M = 2$

The vector field $X_{0,0}$ is given by

$$X_{0,0} = X_{0,0}^{a,0} + Y_{0,0}^{a,0} [x_4 y_4] + \dots$$

We have to study the action of the vector fields $X_{m,n}$ satisfying $m + n = d$ for $d = 0, 1$.

- For $d = 0$, we use the vector field $X_{0,0}$ to kill one of the moduli of the first horizontal level $l_a = 1$ (the one corresponding to the constant term).
- For $d = 1$, we have two vector fields $X_{1,0}$ and $X_{0,1}$. For the vector field $X_{1,0}$, the first non zero coefficient is that of $x_4 y_4$, so we use this vector field to kill corresponding moduli, which is the only one at the second horizontal level $l_a = 2$. The first non zero coefficient of the vector field $X_{0,1}$ is that of $x_4 y_4^2$, so this vector field start acting from the third vertical level which does not exist here.

The decomposition of the vector fields acting at the level l such that $l = d + 1$ on the corresponding basis is given by $X_{0,0}$ for $l = 1$ and $X_{1,0}$ for $l = 2$. So, we do not need to show linear independence.

Example 2. For $N = 4$, $M = 3$, we have $\tau_{3,4} = 5$. In fact, the region of moduli $Q_{M,N}$ is given by

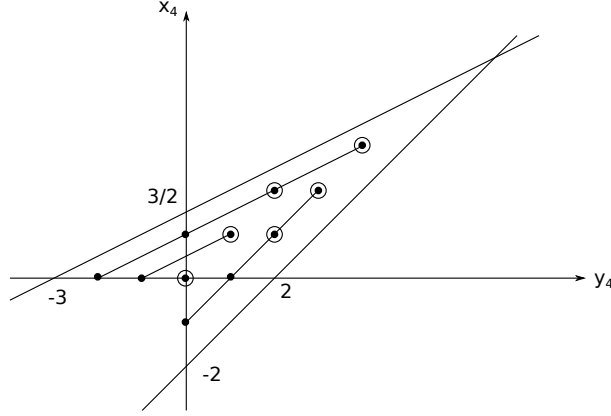

Figure 5: The region $Q_{M,N}$ for $N = 4, M = 3$

The vector field $X_{0,0}$ is given by

$$X_{0,0} = X_{0,0}^{a,0} + X_{0,0}^{b,1}[y_4] + Y_{0,0}^{a,0}[x_4, y_4] + Y_{0,0}^{a,1}[x_4] + \dots$$

The vector fields $X_{m,n}$ satisfying $m + n = d$ for $d = 0, \dots, 4$ are given by

$$\begin{array}{l}
 m + n = 0 : X_{0,0} \quad (l_a = 1) \\
 m + n = 1 : X_{1,0} \quad (l_a = 2) \quad X_{0,1} \quad (l_b = 3) \\
 m + n = 2 : X_{2,0} \quad (l_a = 3) \quad X_{1,1} \quad (l_b = 4) \quad X_{0,2} \quad (l_a = 4) \\
 m + n = 3 : X_{3,0} \quad (l_a = 4) \quad X_{2,1} \quad (l_b = 5) \quad X_{1,2} \quad (l_a = 5) \quad X_{0,3} \quad (l_a = 5) \\
 m + n = 4 : X_{4,0} \quad (l_a = 5) \quad X_{3,1} \quad (-) \quad X_{2,2} \quad (-) \quad X_{1,3} \quad (-) \\
 \quad \quad \quad X_{0,4} \quad (-)
 \end{array}$$

where the level in the parenthesis is the level at which the vector field acts and the dash means that the vector field start acting at a level which does not exist.

The decomposition of the vector fields acting at the level l such that $l = d+1$ on the corresponding basis is given by:

- For $l = 1$, we have $X_{0,0}$.
- For $l = 2$, we have $X_{1,0}$.
- For $l = 3$, we have $X_{2,0}$ and $X_{0,1}$.

$$\begin{array}{l}
 X_{2,0} \quad X_{0,1} \\
 x_4^2 y_4^2 \begin{pmatrix} X_{0,0}^{a,0} & Y_{0,0}^{a,1} \\ X_{0,0}^{b,1} & Y_{0,0}^{a,0} \end{pmatrix} \\
 x_4 y_4^2 \begin{pmatrix} 0 & X_{0,0}^{a,0} \end{pmatrix}
 \end{array}$$

- For $l = 4$, we have $X_{0,2}$.
- For $l = 5$, we have $X_{0,3}$.

Example 3. For $N = 8, M = 7$, we have $\tau_{7,8} = 49$. In fact, the region of moduli $Q_{M,N}$ is given by

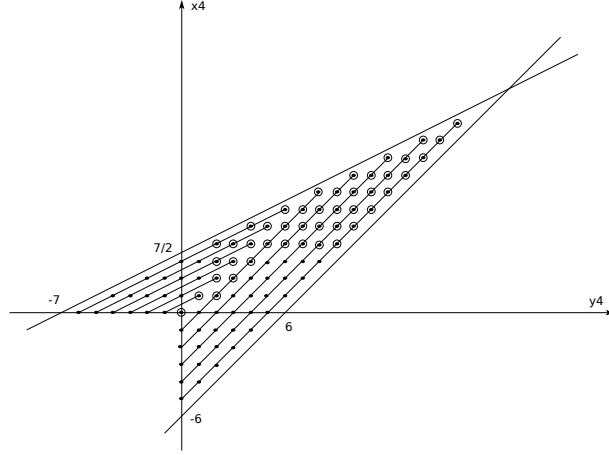

Figure 6: The region $Q_{M,N}$ for $N = 8, M = 7$

The vector field $X_{0,0}$ is given by

$$X_{0,0} = X_{0,0}^{a,0} + \sum_{i=1}^5 X_{0,0}^{b,i} \left[\frac{y_4}{x_4^{i-1}} \right] + \sum_{j=0}^5 Y_{0,0}^{a,j} \left[\frac{x_4}{y_4^{j-1}} \right] + \dots$$

The vector fields $X_{m,n}$ satisfying $m + n = d$ for $d = 0, \dots, 8$ are given by

$m + n = 0 :$	$X_{0,0}$	$(l_a = 1)$						
$m + n = 1 :$	$X_{1,0}$	$(l_a = 2)$	$X_{0,1}$	$(l_b = 3)$				
$m + n = 2 :$	$X_{2,0}$	$(l_a = 3)$	$X_{1,1}$	$(l_b = 4)$	$X_{0,2}$	$(l_a = 4)$		
$m + n = 3 :$	$X_{3,0}$	$(l_a = 4)$	$X_{2,1}$	$(l_b = 5)$	$X_{1,2}$	$(l_a = 5)$	$X_{0,3}$	$(l_a = 5)$
$m + n = 4 :$	$X_{4,0}$	$(l_a = 5)$	$X_{3,1}$	$(l_b = 6)$	$X_{2,2}$	$(l_b = 7)$	$X_{1,3}$	$(l_b = 8)$
	$X_{0,4}$	$(l_a = 6)$						
$m + n = 5 :$	$X_{5,0}$	$(l_a = 6)$	$X_{4,1}$	$(l_b = 7)$	$X_{3,2}$	$(l_b = 8)$	$X_{2,3}$	$(l_b = 9)$
	$X_{1,4}$	$(l_b = 10)$	$X_{0,5}$	$(l_b = 11)$				
$m + n = 6 :$	$X_{6,0}$	$(l_a = 7)$	$X_{5,1}$	$(l_b = 8)$	$X_{4,2}$	$(l_b = 9)$	$X_{3,3}$	$(l_b = 10)$
	$X_{2,4}$	$(l_b = 11)$	$X_{1,5}$	$(l_b = 12)$	$X_{0,6}$	$(l_b = 13)$		
$m + n = 7 :$	$X_{7,0}$	$(l_b = 9)$	$X_{6,1}$	$(l_b = 9)$	$X_{5,2}$	$(l_b = 10)$	$X_{4,3}$	$(l_b = 11)$
	$X_{3,4}$	$(l_b = 12)$	$X_{2,5}$	$(l_b = 13)$	$X_{1,6}$	$(l_b = 14)$	$X_{0,7}$	$(l_b = 15)$
$m + n = 8 :$	$X_{8,0}$	$(l_b = 10)$	$X_{7,1}$	$(l_b = 11)$	$X_{6,2}$	$(l_b = 11)$	$X_{5,3}$	$(l_b = 12)$
	$X_{4,4}$	$(l_b = 13)$	$X_{3,5}$	$(l_b = 14)$	$X_{2,6}$	$(l_b = 15)$	$X_{1,7}$	$(l_b = 16)$
	$X_{0,8}$	$(l_b = 17)$						

The decomposition of the vector fields acting at the level l such that $l = d+1$ on the corresponding basis is given by:

- For $l = 1$, we have $X_{0,0}$.
- For $l = 2$, we have $X_{1,0}$.
- For $l = 3$, we have $X_{2,0}$ and $X_{0,1}$.

$$\begin{matrix} & X_{2,0} & X_{0,1} \\ x_4^2 y_4^2 & \left(\begin{matrix} X_{0,0}^{a,0} & Y_{0,0}^{a,1} \\ 0 & X_{0,0}^{a,0} \end{matrix} \right) \\ x_4 y_4^2 & & \end{matrix}$$

- For $l = 4$, we have $X_{0,2}$, $X_{3,0}$ and $X_{1,1}$.

$$\begin{matrix} & X_{0,2} & X_{3,0} & X_{1,1} \\ x_4^3 y_4^2 & \left(\begin{matrix} Y_{0,0}^{a,3} & 0 & Y_{0,0}^{a,2} \\ Y_{0,0}^{a,2} & X_{0,0}^{a,0} & Y_{0,0}^{a,1} \\ 0 & 0 & X_{0,0}^{a,0} \end{matrix} \right) \\ x_4^3 y_4^3 & & & \\ x_4^2 y_4^3 & & & \end{matrix}$$

- For $l = 5$, we have $X_{0,3}$, $X_{1,2}$, $X_{4,0}$ and $X_{2,1}$.

$$\begin{matrix} & X_{0,3} & X_{1,2} & X_{4,0} & X_{2,1} \\ x_4^4 y_4^2 & \left(\begin{matrix} Y_{0,0}^{a,5} & Y_{0,0}^{a,4} & 0 & Y_{0,0}^{a,3} \\ Y_{0,0}^{a,4} & Y_{0,0}^{a,3} & 0 & Y_{0,0}^{a,2} \\ Y_{0,0}^{a,3} & Y_{0,0}^{a,2} & X_{0,0}^{a,0} & Y_{0,0}^{a,1} \\ 0 & 0 & 0 & X_{0,0}^{a,0} \end{matrix} \right) \\ x_4^4 y_4^3 & & & & \\ x_4^4 y_4^4 & & & & \\ x_4^3 y_4^4 & & & & \end{matrix}$$

- For $l = 6$, we have $X_{0,4}$, $X_{5,0}$ and $X_{3,1}$.

$$\begin{matrix} & X_{0,4} & X_{5,0} & X_{3,1} \\ x_4^5 y_4^4 & \left(\begin{matrix} Y_{0,0}^{a,5} & 0 & Y_{0,0}^{a,2} \\ Y_{0,0}^{a,4} & X_{0,0}^{a,0} & Y_{0,0}^{a,1} \\ 0 & 0 & X_{0,0}^{a,0} \end{matrix} \right) \\ x_4^5 y_4^5 & & & \\ x_4^4 y_4^5 & & & \end{matrix}$$

- For $l = 7$, we have $X_{6,0}$, $X_{4,1}$ and $X_{2,2}$.

$$\begin{matrix} & X_{6,0} & X_{4,1} & X_{2,2} \\ x_4^6 y_4^6 & \left(\begin{matrix} X_{0,0}^{a,0} & Y_{0,0}^{a,1} & * \\ 0 & X_{0,0}^{a,0} & Y_{0,0}^{a,1} \\ 0 & 0 & X_{0,0}^{a,0} \end{matrix} \right) \\ x_4^5 y_4^6 & & & \\ x_4^4 y_4^6 & & & \end{matrix}$$

- For $l = 8$, we have $X_{5,1}$, $X_{3,2}$ and $X_{1,3}$.

$$\begin{matrix} & X_{5,1} & X_{3,2} & X_{1,3} \\ x_4^6 y_4^7 & \left(\begin{matrix} X_{0,0}^{a,0} & Y_{0,0}^{a,1} & * \\ 0 & X_{0,0}^{a,0} & Y_{0,0}^{a,1} \\ 0 & 0 & X_{0,0}^{a,0} \end{matrix} \right) \\ x_4^5 y_4^7 & & & \\ x_4^4 y_4^7 & & & \end{matrix}$$

- For $l = 9$, we have $X_{6,1}$, $X_{4,2}$, $X_{2,3}$ and $X_{7,0}$.

$$\begin{array}{c} x_4^7 y_4^8 \\ x_4^6 y_4^8 \\ x_4^5 y_4^8 \\ x_4^4 y_4^8 \end{array} \begin{pmatrix} X_{0,0}^{a,0} & Y_{0,0}^{a,1} & * & X_{0,0}^{b,1} \\ 0 & X_{0,0}^{a,0} & Y_{0,0}^{a,1} & X_{0,0}^{b,2} \\ 0 & 0 & X_{0,0}^{a,0} & X_{0,0}^{b,3} \\ 0 & 0 & 0 & X_{0,0}^{b,4} \end{pmatrix}$$

- For $l = 10$, we have $X_{5,2}$, $X_{3,3}$, $X_{1,4}$ and $X_{8,0}$.

$$\begin{array}{c} x_4^7 y_4^9 \\ x_4^6 y_4^9 \\ x_4^5 y_4^9 \\ x_4^4 y_4^9 \end{array} \begin{pmatrix} X_{0,0}^{a,0} & Y_{0,0}^{a,1} & * & X_{0,0}^{b,2} \\ 0 & X_{0,0}^{a,0} & Y_{0,0}^{a,1} & X_{0,0}^{b,3} \\ 0 & 0 & X_{0,0}^{a,0} & X_{0,0}^{b,4} \\ 0 & 0 & 0 & X_{0,0}^{b,5} \end{pmatrix}$$

Example 4. For $N = 9$, $M = 6$, we have $\tau_{6,9} = 47$. The vector field $X_{0,0}$ is given by

$$X_{0,0} = X_{0,0}^{a,0} + \sum_{i=1}^4 X_{0,0}^{b,i} \left[\frac{y_4}{x_4^{i-1}} \right] + \sum_{j=0}^6 Y_{0,0}^{a,j} \left[\frac{x_4}{y_4^{j-1}} \right] + \dots$$

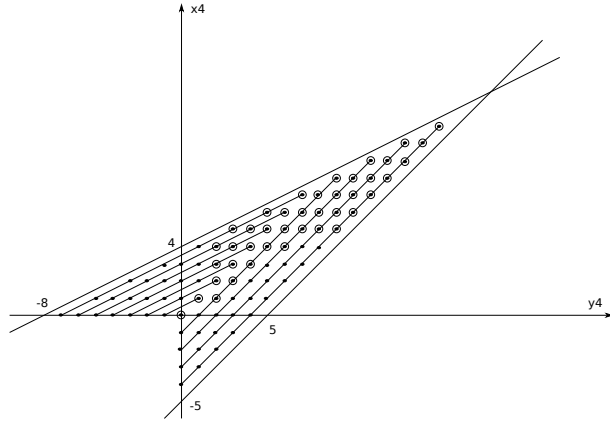

Figure 7: The region $Q_{M,N}$ for $N = 9$, $M = 6$

The vector fields $X_{m,n}$ satisfying $m+n=d$ for $d=0, \dots, 9$ are given by

$$\begin{array}{l}
m+n=0: X_{0,0} \quad (l_a=1) \\
m+n=1: X_{1,0} \quad (l_a=2) \quad X_{0,1} \quad (l_b=3) \\
m+n=2: X_{2,0} \quad (l_a=3) \quad X_{1,1} \quad (l_b=4) \quad X_{0,2} \quad (l_a=4) \\
m+n=3: X_{3,0} \quad (l_a=4) \quad X_{2,1} \quad (l_b=5) \quad X_{1,2} \quad (l_a=5) \quad X_{0,3} \quad (l_a=5) \\
m+n=4: X_{4,0} \quad (l_a=5) \quad X_{3,1} \quad (l_b=6) \quad X_{2,2} \quad (l_b=7) \quad X_{1,3} \quad (l_a=6) \\
\quad X_{0,4} \quad (l_a=6) \\
m+n=5: X_{5,0} \quad (l_a=6) \quad X_{4,1} \quad (l_b=7) \quad X_{3,2} \quad (l_b=8) \quad X_{2,3} \quad (l_b=9) \\
\quad X_{1,4} \quad (l_b=10) \quad X_{0,5} \quad (l_a=7) \\
m+n=6: X_{6,0} \quad (l_a=7) \quad X_{5,1} \quad (l_b=8) \quad X_{4,2} \quad (l_b=9) \quad X_{3,3} \quad (l_b=10) \\
\quad X_{2,4} \quad (l_b=11) \quad X_{1,5} \quad (l_b=12) \quad X_{0,6} \quad (l_b=13) \\
m+n=7: X_{7,0} \quad (l_a=8) \quad X_{6,1} \quad (l_b=9) \quad X_{5,2} \quad (l_b=10) \quad X_{4,3} \quad (l_b=11) \\
\quad X_{3,4} \quad (l_b=12) \quad X_{2,5} \quad (l_b=13) \quad X_{1,6} \quad (l_b=14) \quad X_{0,7} \quad (l_b=15) \\
m+n=8: X_{8,0} \quad (l_b=10) \quad X_{7,1} \quad (l_b=10) \quad X_{6,2} \quad (l_b=11) \quad X_{5,3} \quad (l_b=12) \\
\quad X_{4,4} \quad (l_b=13) \quad X_{3,5} \quad (l_b=14) \quad X_{2,6} \quad (l_b=15) \quad X_{1,7} \quad (l_b=16) \\
\quad X_{0,8} \quad (-) \\
m+n=9: X_{9,0} \quad (l_b=11) \quad X_{8,1} \quad (l_b=12) \quad X_{7,2} \quad (l_b=12) \quad X_{6,3} \quad (l_b=13) \\
\quad X_{5,4} \quad (l_b=14) \quad X_{4,5} \quad (l_b=15) \quad X_{3,6} \quad (l_b=16) \quad X_{2,7} \quad (-) \\
\quad X_{1,8} \quad (-) \quad X_{0,9} \quad (-)
\end{array}$$

The decomposition of the vector fields acting at the level l such that $l=d+1$ on the corresponding basis is given by:

- For $l=1$, we have $X_{0,0}$.
- For $l=2$, we have $X_{1,0}$.
- For $l=3$, we have $X_{2,0}$ and $X_{0,1}$.

$$\begin{array}{c}
X_{2,0} \quad X_{0,1} \\
x_4^2 y_4^2 \begin{pmatrix} X_{0,0}^{a,0} & Y_{0,0}^{a,1} \\ 0 & X_{0,0}^{a,0} \end{pmatrix} \\
x_4 y_4^2
\end{array}$$

- For $l=4$, we have $X_{0,2}$, $X_{3,0}$ and $X_{1,1}$.

$$\begin{array}{c}
X_{0,2} \quad X_{3,0} \quad X_{1,1} \\
x_4^3 y_4^2 \begin{pmatrix} Y_{0,0}^{a,3} & 0 & Y_{0,0}^{a,2} \\ Y_{0,0}^{a,2} & X_{0,0}^{a,0} & Y_{0,0}^{a,1} \\ 0 & 0 & X_{0,0}^{a,0} \end{pmatrix} \\
x_4^3 y_4^3 \\
x_4^2 y_4^3
\end{array}$$

- For $l=5$, we have $X_{0,3}$, $X_{1,2}$, $X_{4,0}$ and $X_{2,1}$.

$$\begin{array}{c}
X_{0,3} \quad X_{1,2} \quad X_{4,0} \quad X_{2,1} \\
x_4^4 y_4^2 \begin{pmatrix} Y_{0,0}^{a,5} & Y_{0,0}^{a,4} & 0 & Y_{0,0}^{a,3} \\ Y_{0,0}^{a,4} & Y_{0,0}^{a,3} & 0 & Y_{0,0}^{a,2} \\ Y_{0,0}^{a,3} & Y_{0,0}^{a,2} & X_{0,0}^{a,0} & Y_{0,0}^{a,1} \\ 0 & 0 & 0 & X_{0,0}^{a,0} \end{pmatrix} \\
x_4^4 y_4^3 \\
x_4^4 y_4^4 \\
x_4^3 y_4^4
\end{array}$$

- For $l = 6$, we have $X_{0,4}$, $X_{1,3}$, $X_{5,0}$ and $X_{3,1}$.

$$\begin{array}{c} x_4^5 y_4^3 \\ x_4^5 y_4^4 \\ x_4^5 y_4^5 \\ x_4^4 y_4^5 \end{array} \begin{pmatrix} X_{0,4} & X_{1,3} & X_{5,0} & X_{3,1} \\ Y_{0,0}^{a,6} & Y_{0,0}^{a,5} & 0 & Y_{0,0}^{a,3} \\ Y_{0,0}^{a,5} & Y_{0,0}^{a,4} & 0 & Y_{0,0}^{a,2} \\ Y_{0,0}^{a,4} & Y_{0,0}^{a,3} & X_{0,0}^{a,0} & Y_{0,0}^{a,1} \\ 0 & 0 & 0 & X_{0,0}^{a,0} \end{pmatrix}$$

- For $l = 7$, we have $X_{0,5}$, $X_{6,0}$, $X_{4,1}$ and $X_{2,2}$.

$$\begin{array}{c} x_4^6 y_4^5 \\ x_4^6 y_4^6 \\ x_4^5 y_4^6 \\ x_4^4 y_4^6 \end{array} \begin{pmatrix} X_{0,5} & X_{6,0} & X_{4,1} & X_{2,2} \\ Y_{0,0}^{a,6} & 0 & Y_{0,0}^{a,2} & * \\ Y_{0,0}^{a,5} & X_{0,0}^{a,0} & Y_{0,0}^{a,1} & * \\ 0 & 0 & X_{0,0}^{a,0} & Y_{0,0}^{a,1} \\ 0 & 0 & 0 & X_{0,0}^{a,0} \end{pmatrix}$$

- For $l = 8$, we have $X_{7,0}$, $X_{5,1}$ and $X_{3,2}$.

$$\begin{array}{c} x_4^7 y_4^7 \\ x_4^6 y_4^7 \\ x_4^5 y_4^7 \end{array} \begin{pmatrix} X_{7,0} & X_{5,1} & X_{3,2} \\ X_{0,0}^{a,0} & Y_{0,0}^{a,1} & * \\ 0 & X_{0,0}^{a,0} & Y_{0,0}^{a,1} \\ 0 & 0 & X_{0,0}^{a,0} \end{pmatrix}$$

- For $l = 9$, we have $X_{6,1}$, $X_{4,2}$ and $X_{2,3}$.

$$\begin{array}{c} x_4^7 y_4^8 \\ x_4^6 y_4^8 \\ x_4^5 y_4^8 \end{array} \begin{pmatrix} X_{6,1} & X_{4,2} & X_{2,3} \\ X_{0,0}^{a,0} & Y_{0,0}^{a,1} & * \\ 0 & X_{0,0}^{a,0} & Y_{0,0}^{a,1} \\ 0 & 0 & X_{0,0}^{a,0} \end{pmatrix}$$

- For $l = 10$, we have to choose four vector fields among $X_{7,1}$, $X_{5,2}$, $X_{3,3}$, $X_{1,4}$ and $X_{8,0}$.

$$\begin{array}{c} x_4^8 y_4^9 \\ x_4^7 y_4^9 \\ x_4^6 y_4^9 \\ x_4^5 y_4^9 \end{array} \begin{pmatrix} X_{7,1} & X_{5,2} & X_{3,3} & X_{1,4} \\ X_{0,0}^{a,0} & Y_{0,0}^{a,1} & * & * \\ 0 & X_{0,0}^{a,0} & Y_{0,0}^{a,1} & * \\ 0 & 0 & X_{0,0}^{a,0} & Y_{0,0}^{a,1} \\ 0 & 0 & 0 & X_{0,0}^{a,0} \end{pmatrix}$$

References

- Genzmer, Y., Paul, E., 2011. Normal forms of foliations and curves defined by a function with a generic tangent cone. *Moscow Math. J.* 11, 41–72.
- Genzmer, Y., Paul, E., 2016. Moduli spaces for topologically quasi-homogeneous functions. *Journal of Singularities* 14, 3–33.
- Granger, J., 1979. Sur un espace de modules de germe de courbe plane. *Bull. Sc. math.* 103, 3–16.
- Hefez, A., Hernandes, M., 2009. Analytic classification of plane branches up to multiplicity 4. *J. Symbolic Comput.* 44, 626–634.
- Hefez, A., Hernandes, M., 2011. The analytic classification of plane branches. *Bull. Lond. Math. Soc.* 43, 289–298.
- Hefez, A., Hernandes, M., 2013. Algorithms for the implementation of the analytic classification of plane branches. *J. Symbolic Comput.* 50, 308–313.
- J. Briancon, M.G., Maisonobe, P., 1988. Le nombre de modules du germe de courbe plane $x^a + y^b = 0$. *Math. Ann.* 279, 535–551.
- Loubani, J., 2019. Moduli spaces of a family of topologically non quasi-homogeneous functions. *Publicacions Matemàtiques.* 63, 81–104.
- Mattei, J., 1991. Modules de feuilletages holomorphes singuliers: I équisingularité. *Invent. Math.* 103, 297–325.
- Mattei, J., 2000. Quasihomogénéité et équiréductibilité de feuilletages holomorphes en dimension 2. *Astérisque* 261 S.M.F. 253-276 .
- Saito, K., 1971. Quasihomogene isolierte singularitäten von hyperflächen. *Invent. Math.* 14, 123.
- Zariski, O., 1986. Le problème des modules pour les branches planes. Hermann, Paris, second edition, 1986. Course given at the Centre de Mathématiques de l'École Polytechnique, Paris, October-November 1973 .