



HAL
open science

A precise non-asymptotic complexity analysis of parallel hash functions without tree topology constraints

Kevin Atighehchi

► **To cite this version:**

Kevin Atighehchi. A precise non-asymptotic complexity analysis of parallel hash functions without tree topology constraints. *Journal of Parallel and Distributed Computing*, 2020, 137, pp.246 - 251. 10.1016/j.jpdc.2019.10.002 . hal-03488794

HAL Id: hal-03488794

<https://hal.science/hal-03488794v1>

Submitted on 21 Jul 2022

HAL is a multi-disciplinary open access archive for the deposit and dissemination of scientific research documents, whether they are published or not. The documents may come from teaching and research institutions in France or abroad, or from public or private research centers.

L'archive ouverte pluridisciplinaire **HAL**, est destinée au dépôt et à la diffusion de documents scientifiques de niveau recherche, publiés ou non, émanant des établissements d'enseignement et de recherche français ou étrangers, des laboratoires publics ou privés.



Distributed under a Creative Commons Attribution - NonCommercial 4.0 International License

A Precise Complexity Analysis of Parallel Hash Functions Without Tree Topology Constraints

Kevin Atighehchi

GREYC, Université de Caen Normandie, France

Abstract

A recent work shows how we can optimize a tree based mode of operation for a hash function where the sizes of input message blocks and digest are the same, subject to the constraint that the involved tree structure has all its leaves at the same depth. In this work, we show that we can further optimize the running time of such a mode by using a tree having leaves at all its levels. We make the assumption that the input message block has a size a multiple of that of the digest and denote by d the ratio block size over digest size. The running time is evaluated in terms of number of operations performed by the hash function, *i.e.* the number of calls to its underlying function. It turns out that a digest can be computed in $\lceil \log_{d+1}(l/2) \rceil + 2$ evaluations of the underlying function using $\lceil l/2 \rceil$ processors, where l is the number of blocks of the message. Other results of interest are discussed, such as the optimization of the parallel running time for a tree of restricted height.

Keywords: Hash functions, Merkle trees, Parallel algorithms, Prefix-free Merkle-Damgård, Sponge functions

1. Introduction

On the topic of cryptographic hashing, parallelizable operating modes were proposed in some SHA-3 candidates (Skein [1], MD6 [2], SANDstorm [3]), in BLAKE2 [4] and more recently in the Special Publication NIST SP 800-185 [5].

Email address: kevin.atighehchi@unicaen.fr (Kevin Atighehchi)

Preprint submitted to Elsevier

December 1, 2018

All these propositions make use of simple tree topologies, and their in-depth analyses have never been performed. In this paper, we are interested in the problem of finding a tree structured circuit topology to optimize both the parallel running time and the number of involved processors (*i.e.* in depth and width). We consider tree hashing modes for an inner hash function (or variable-input-length compression function) denoted f . The ratio block size over digest size is an integer denoted d . For instance, if $d = 1$, they may correspond to SBL (Single-Block-Length) hash functions based on a block cipher having the key and the block of the same size. We make the assumption that the hash function needs only $\lceil l/d \rceil$ invocations to the underlying primitive to process an l -block message, and we will see that some precomputations are required to achieve such a running time.

Let us assume a hash tree of height h having all its leaves (*i.e.* message blocks) at the same depth. If we denote by a_i the arity of level i for $i = 1 \dots h$, and if $d = 1$, then the parallel running time to obtain the root node value is $\sum_{i=1}^h a_i$. A recent work [6, 7] has shown that good parameters can be selected to construct such trees that minimize both the running time and the number of processors. Under the same topology constraint, other tree hashing modes with memory concerns were proposed in [8], but the authors only gave asymptotic complexity using the big-oh notation. The aim of the present paper is to show that we can further decrease the parallel running time of a tree-based hash function by removing this structural constraint on the tree. We then remark that the allocation of tasks to the processors is a bit more subtle, and that the parallel running time is no longer the sum of the level arities. Our contributions are manifolds:

- We first recall that it is possible to design a hash function whose implementation will behave like an idealized hash function from the rate standpoint. In particular, assuming precomputations, this hash function requires l calls (or $\lceil l/d \rceil$ calls) to the underlying primitive to process a message of l blocks. This resulting sequential hash function is then used

as building block for tree hashing.

- We show the parallel running time which can be obtained using hash trees of smallest height. In particular, we state a result in which both the running time and the number of involved processors are optimized. A tree of minimized height has the benefit of minimizing the memory consumption.
- We then address the case of trees of unrestricted height. We show the optimal parallel running time which can be obtained in this case and discuss how the number of involved processors can be decreased without changing this running time.
- We finally consider a situation in which we have a *bounded parallelism*. We show the optimal parallel running time which can be obtained with a fixed number of processors.
- Except for the *bounded parallelism* case, all the proposed tree-based operating modes support live-streaming when the number of processors available is less than the stated bound.

This paper is organized in the following way. We give some definitions about trees and hash functions in Section 2. We address the optimization of tree constructions suitable for parallel hashing in Section 3. Finally, we conclude the paper in Section 4.

2. Terminology and Background Information

Throughout this paper, we use two conventions for the representation of a node. With the first convention, a node is an input to f . It is represented by a series of circles connected by dotted lines, and each circle contains either a message block or a chaining value. With the second convention¹, a node is the result of f called on a data composed of the node's children. A node value then

¹This is the convention used to describe Merkle trees.

corresponds to an image by such a function and a child of this node can be either an other image or a message block. In this paper, a k -ary tree of height h is a tree having the following properties:

- The root node (at level h) can be of arity a , with $1 < a \leq k$.
- A level i ($\neq h$) has all its nodes of arity k , except the rightmost one that can be of smaller arity.

We define the arity of a level in the tree as being the greatest node arity in this level.

Let us denote the block size and the digest size N_b and N_o respectively. We make the assumption that $d = N_b/N_o$ is a positive integer, and we often consider that $d = 1$ for simplicity reasons. A node in the tree is computed using an inner VIL function that iteratively processes message blocks of size N_b bits using an underlying function (a block cipher, a permutation or another compression function) and produces a digest of N_o bits. The underlying function is considered to be the lowest level function. For instance, the hash function Skein [1] is based on a VIL compression function, itself based on a lowest level primitive, the tweakable block cipher Threefish.

We assume that the evaluation of the inner function requires a number of calls to its underlying function equal to the number of blocks of the message. At first sight we could think that this kind of primitive is rare since: (i) there is usually a padding which is done at the end of the message. For certain message sizes, this padding requires one more call to the underlying function; (ii) In the hash functions like SHA-1 and SHA-2, the MD-strengthening add another block containing the message size. However, we show that we can construct an inner VIL function that can satisfy a running time of l unit of times for a message of l blocks. Besides, some existing inner functions are already of this type, such as the VIL compression function based on the UBI (Unique Block Iteration) chaining mode of Skein [1] and some other *single-block-length* hash functions [9, 10].

In this paper, the time complexity corresponds to the number of evaluations of the lowest level function and we use the term *unit of time* for one evaluation of such a function.

2.1. Computation Model

We use the PRAM (Parallel Random Access Machine) model of computation, assuming the strategy EREW (Exclusive Read Exclusive Write). Tree-based hash functions do not require that distinct processors read or write simultaneously at a same memory location. The considered basic operation depends on the type of inner function. This operation is a call to a permutation if the inner function is a sponge-based hash function or a call to a block cipher if this is a Merkle-Damgård based hash function².

Except when otherwise specified, the parallel running time corresponds to the running time when the number of processors is not *a priori* bounded. As a consequence, the message is supposed to be already available. In the hash tree constructions that we propose, if the number of chaining values is denoted n_{cv} and if the root node is not counted as such, then the number of processors is equal to $n_{cv}+1$. Indeed, the chaining values are computed by distinct processors.

2.2. Concretizing an Idealized Rate for the Inner Function

According to Bertoni *et al.* [11], a hash function designed by using a tree-based operating mode is indistinguishable from a random oracle if three conditions (namely *tree decodability*, *message completeness* and *final-node separability*) are met and if the operated inner function is indistinguishable from a random oracle. In particular, it was shown that the conditions are fulfilled by a proper encoding of the inputs to the inner function.

If we want to use an inner function based on the Merkle-Damgård construction, we need to use the modifications proposed by Coron *et al.* [12], which

²An MD-based hash function iterates a compression function, itself based on an implicitly or explicitly defined block-cipher.

ensure that this inner function will be indifferentiable from a random oracle.

Inner function based on the prefix-free MD. We choose to use a modification of the Merkle-Damgård construction, proposed by Coron *et al.* [12]. Let us denote M a message to hash, padded with a bit 1 and the minimal number of bits 0, such that the length of the padded message is a multiple of N_b . The modification consists, before applying the MD algorithm, in prepending to this padded message a block containing the length of M in bits. We denote by f' the resulting hash function. Coron *et al.* show that f' is indifferentiable from a random oracle.

Let us suppose that the inner function used in the tree-based hash function is f' . Following the guidelines stated in [11], prepending two bits to the inputs to f' is sufficient to ensure the indifferentiability of the resulting tree-based hash function. The values of these bits depend on the type of f' -input, *i.e.* the location of the input in the tree topology. In this paper, we choose to use $N_b - 1$ bits to encode the type of f' -input, where only two bits can be non-zero. For instance the binary encoding can be $b_0b_10^{N_b-3}$, where the values of b_0 and b_1 depend on the type of f' -input. We can remark that considering the prefix-free encoding and this second encoding, the first bit of the message is at the end of the second block. Our argument is that we can precompute all the possible hash states that result from the processing of the second block. If the number of possible input sizes (before padding or any prepending) is k then the number of precomputed hash states is exactly $8k$. Thus, with these precomputed values, the running time to process with f' an input that can fit into s blocks is exactly equal to s units of time.

Inner function based on a sponge construction. We could use a hash function like Keccak [13] which does not require to embed the message size in the input. This hash function, constructed on top of a permutation, uses a padding 10^*1 at the end of the message so that the message bitsize corresponds

to a multiple of the block size. Specifically, the appending consists of the bit 1, followed by the minimal number of bits 0, followed by a bit 1. As in the previous solution, the computation of the nodes requires to format appropriately the inputs of this function, using the necessary encoding (at least two bits) for sound tree hashing [11]. The trick is to prepend to the input an encoding consisting of $N_b - 2$ bits, where only 2 bits can be non-zero (the values of these bits depend on the type of input). We thus observe that the two first bits of the message are at the end of the first block. We can precompute all the possible hash states resulting from the processing of this first block. There are four possibilities for the two first bits of the message, and four possibilities for the choice of the encoding, for a total of sixteen possible hash states.

Inner function based on the compression function of Skein. Skein [1] uses a variable-input-length compression function which requires l invocations to the tweakable block cipher Threefish to compress a message of l blocks. This ideal rate is due to the fact that the message is not padded when it is already a multiple of the block size. The information of the lack of padding is included in the tweak, thus providing the same functionality as reversible padding. This compression function is indistinguishable of a random oracle if Threefish acts as an ideal cipher. As in the case before, we just have to prepend to the message an encoding of N_b bits in order to distinguish 4 types of input to the compression function. In fact, only two are sufficient and the remaining bits serves only to reduce the number of hash states to precompute, *i.e.* 4 hash states.

3. Optimal Trees Having Their Leaves at All the Levels

The idea of processing both message blocks and chaining values (non-leaf nodes, *i.e.* digests) using a single inner function evaluation was suggested in [14] (under the name of *kangaroo hopping*) in order to avoid certain computation overheads. With our assumptions, we first apply this idea for all nodes of a tree

of restricted height with the aim of optimizing the parallel running time, and then we apply it to the case of trees of unrestricted height.

In the following results, the considered inner function has an idealized running time and is devoid of the padding overhead. If the padding is not neglected, the number of processors is underestimated:

- If the inner function is the sponge-based construction defined above, the number of involved processors should be multiplied by four, because two bits have to be guessed at each parallel step.
- If the inner function is the prefix-free MD construction defined above, the number of involved processors should be multiplied by two, because one bit has to be guessed at each parallel step.

For the sake of simplification, we first focus on the case $d = 1$. The case $d > 1$ is discussed in the subsequent subsection.

3.1. Case $d = 1$ (or $N_b = N_o$)

An algorithm for a tree of height 2. Let us consider a message of size l , whose blocks are denoted m_1, m_2, \dots, m_l . The processors are indexed P_i with $i \geq 1$, and we make the assumption that they start their computations at the same time. The message is subdivided in chunks of variable size to be distributed to each processor:

- P_1 and P_2 each receives a chunk of 2 blocks and applies the inner function on these chunks. P_2 computes the hash of $m_3||m_4$, while P_1 computes the hash of $m_1||m_2$ without finalizing it. In other words, P_1 prepares to receive further consecutive blocks. We denote by c_2 the digest computed by P_2 .
- As long as there remains message blocks, P_i (with $i \geq 3$) receives i blocks and applies the inner function on their concatenation. We denote by c_i the resulted digest computed by P_i for $i \geq 3$. Note that P_i can possibly process less than i blocks if the end of the message is reached.

- P_1 continues to evaluate the inner function on the collected digests c_2, \dots, c_k as they arrive. The evaluation of the inner function is resumed immediately when a digest c_i is available.
- Assuming that P_k is the last processor that has received blocks, the final digest computed by P_1 corresponds to the evaluation of the inner function on

$$m_1 \| m_2 \| c_2 \| c_3 \| \dots \| c_{k-1} \| c_k.$$

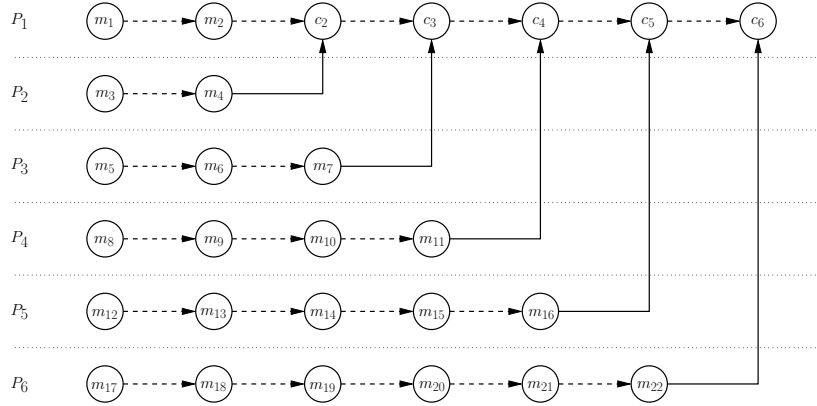

Figure 1: Processing of a message of 22 blocks using 8 processors, denoted P_1, P_2, \dots, P_6 . We can see that P_1 and P_2 each process 2 blocks of the message, while P_i , with $i \geq 3$, processes i blocks of the message. The chaining values c_2, c_3, \dots, c_6 are collected and processed by P_1 as soon as they are computed.

An example of execution of this algorithm is depicted in Figure 1. The running time of this hash function is the running time for computing c_k plus one, *i.e.*, $k + 1$ units of time. If the last processor receives a single block, this one can be processed by the first processor in order to save one processor, while leaving unchanged the running time of $k + 1$. Note that k is such that $\sum_{i=1}^k i \geq l - 1$, *i.e.* such that $k^2 + k - 2(l - 1) \geq 0$. This inequation has two solutions $\frac{-1 \pm \sqrt{8l-7}}{2}$, of which only one is positive for $l \geq 1$. The solution is then $k = \left\lceil \frac{-1 + \sqrt{8l-7}}{2} \right\rceil$. Among the tree structures of height 2, the one used in the algorithm above leads to an optimal parallel running time. While conserving this running time, one may desire to decrease the number of involved processors.

Theorem 1. *Let a message of length l blocks such that $l \geq 2$. We can construct a hash tree of height 2 allowing a parallel running time of $k + 1$ units of time, using $k - i + 2$ processors, where*

$$k = \left\lceil \frac{-1 + \sqrt{4i^2 - 12i + 8l + 1}}{2} \right\rceil = \left\lceil \frac{-1 + \sqrt{8l - 8}}{2} \right\rceil$$

and

$$i = \max_j \operatorname{argmin}_j \left\lceil \frac{-1 + \sqrt{4j^2 - 12j + 8l + 1}}{2} \right\rceil < \left\lceil \frac{\sqrt{4 + 4\sqrt{8l - 8}} + 3}{2} \right\rceil.$$

PROOF. We seek to maximize i and minimize k such that Processor P_1 processes i message blocks and $k - i + 1$ chaining values, and $P_2, P_3, \dots, P_{k-i+1}, P_{k-i+2}$ process respectively $i, i + 1, \dots, k - 1, k$ message blocks. The final digest computed by P_1 corresponds to the evaluation of the inner function on

$$m_1 \| m_2 \| \cdots \| m_i \| c_i \| c_{i+1} \| \cdots \| c_{k-1} \| c_k.$$

Thus, we seek to minimize k such that $\sum_{j=i-1}^k j \geq l - 1$. We have to solve the inequation $k^2 - k - i^2 + 3i - 2l \geq 0$. The discriminant $\Delta = 4i^2 - 12i + 8l + 1$ is strictly positive iff $i^2 - 3i + 2l + 1/4 \geq 0$. Since this last inequality is verified for $n \geq i \geq 1$, we have two solutions of which only one is positive. We deduce that $k = \left\lceil \frac{-1 + \sqrt{4i^2 - 12i + 8l + 1}}{2} \right\rceil$ for $n \geq i \geq 1$. Let us consider the function

$$f(x) = \frac{-1 + \sqrt{4x^2 - 12x + 8l + 1}}{2}$$

whose derivative is $f'(x) = \frac{2x-3}{\sqrt{8l-4x^2-12x+1}}$. Solving the equation $f'(x) = 0$ leads to the solution $x = 3/2$. Since $f(x)$ is increasing for $x > 3/2$, we now have to seek the maximum integer x satisfying $\left\lceil \frac{-1 + \sqrt{4x^2 - 12x + 8l + 1}}{2} \right\rceil = \lceil f(3/2) \rceil$. We can upper bound x such that $f(x) < f(3/2) + 1$, leading to the expected result.

According to [8], for a tree of height k , the optimal parallel running time is in $O(l^{\frac{1}{k}})$, where l is the size of the message. This result was shown for both the hashing of stored content (the size of the message has to be known in advance) and the hashing of live-streamed content. The construction above, which supports the processing of live-streamed content, does not contradict this

result. Anyway, we recall that in our settings, the message is supposed to be already available, and thus the need of the message size as input to the algorithm does not matter. We see here that the optimization of such a tree using both *kangaroo hopping* and increasing input sizes is interesting. One advantage of using a tree of restricted height is its limited memory usage in a sequential execution of the algorithm. If memory usage for a sequential execution is not a concern, we can consider trees of unrestricted height.

Theorem 2. *Let a message of length l blocks. We can construct a hash tree allowing a parallel running time of exactly $\lceil \log_2 l \rceil + 1$ units of time, using $\lceil l/2 \rceil$ processors.*

PROOF. We first give the construction of a tree structure. Then, we consider a hash function based on it, and we give a scheduling strategy to perform all the computations in parallel. Let us consider a binary tree of height $h = \lceil \log_2 l \rceil$. We denote by l_i the number of nodes of level $i \geq 1$. Remark that this binary tree can be such that all its leaves are at the same depth and $l_i = \lceil l/2^i \rceil$. The l_i nodes of the level i are indexed. For $j = 1 \dots l_i$, one node of this level is denoted N_j and, in particular, its leftmost child is denoted $N_{j,LC}$. *Note that if N_j has a single child, this latter is still considered as its leftmost child.* At each level i of this tree, starting from level 2 up to level h , we transform the nodes in the following way: for $j = 1 \dots l_i$, the node $N_{j,LC}$ is discarded and its children become the children of N_j . *We notice that once this operation is performed, a node N_j can have a higher number of children.* The resulting transformed tree is no longer a binary tree and its leaves are located at all the levels. An example of execution of this algorithm is depicted in Figure 2.

We now consider a hash function based on this tree structure. The computations are done in parallel in the following way: In a same parallel step, each processor starts the computation of one of the $\lceil l/2 \rceil$ nodes that has leaves. This parallel step requires 2 units of time. Hence, the computations of these nodes (or of their parent nodes) can progress in a parallel step of one unit of time. We need to repeat such a parallel step as many times as necessary to complete the

processing of this hash tree, *i.e.*, $\lceil \log_2 l \rceil - 1$ times. We then deduce a parallel running time of $\lceil \log_2 l \rceil - 1 + 2$ units of time. The number of involved processors corresponds to the number of nodes having leaves, *i.e.* $\lceil l/2 \rceil$. An example of parallel hash computation is depicted in Figure 3.

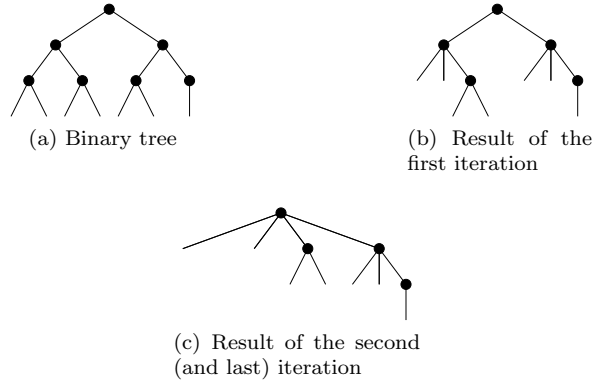

Figure 2: Derivation of a tree structure having its leaves at all the levels from a classic binary tree that processes a message of 7 blocks

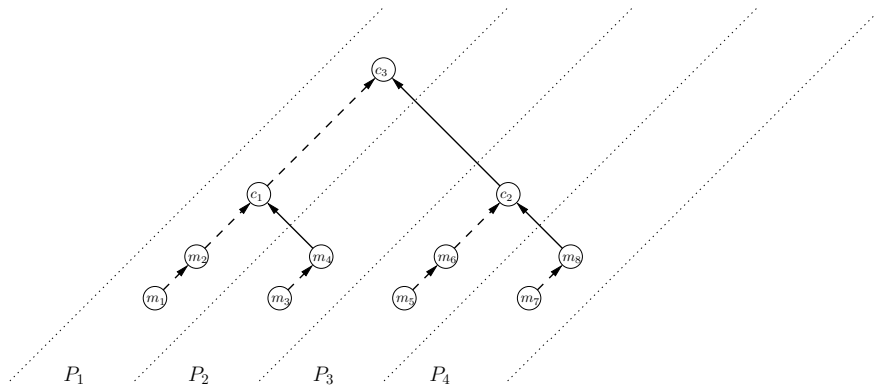

Figure 3: Example of the processing of 8 blocks m_1, m_2, \dots, m_8 , using another tree representation. We have 4 processors denoted P_1, P_2, P_3 and P_4 . A dotted line represents a serial computation using the same hash context, while a solid line indicates that a hash state is used by another hash context. The encircled message blocks or chaining values that are connected with a dotted line are in the same f -input. For instance, the processor P_2 computes the hash of $m_3 || m_4$, denoted c_1 . The chaining values c_1 and c_3 are used by the hash context of the processor P_1 . The parallel running time to compute the root node is equal to the running time required for computing the hash of $m_1 || m_2 || c_1 || c_3$, *i.e.*, 4 units of time.

Remark. Assuming a message of length l blocks, the parallel running time of $\lceil \log_2 l \rceil + 1$ is optimal. Indeed, this is clearly true for a message of 4 blocks which requires 3 units of time. Let us suppose that the running time of $k + 1$ is optimal for a message of length 2^k . If we cannot process more than 2^k blocks in $k + 1$ units of time, processing 2^k more blocks requires at least one more unit of time. Thus, the running time of $k + 2$ is still optimal for a message of length 2^{k+1} .

Performances improvements. The (parallel) running time of such a tree is to be compared with the running time of an optimal tree having its leaves at the same depth [7], *i.e.* approximately $3\lceil \log_3 l \rceil$. This represents, approximately, a 2x speedup.

What if we apply the algorithm above on a ternary tree to construct another tree? The transformed tree would lead to a parallel running time of at most $(\lceil \log_3 l \rceil - 1) \cdot 2 + 3 = 2\lceil \log_3 l \rceil + 1$. More precisely, if the ternary tree has a root node of arity 3, then the hash function based on the transformed tree has a parallel running time of exactly $2\lceil \log_3 l \rceil + 1$. Otherwise, if it is of arity 2, the transformed tree leads to a parallel running time of exactly $2\lceil \log_3 l \rceil$.

For a large message length l , we have $\lceil \log_2 l \rceil + 1 < 2\lceil \log_3 l \rceil$. It is thus more interesting to use the topology derived from a binary tree. For a finite and small number of l , the tree topology derived from a ternary tree gives the same running time. For these message lengths, such a topology is preferable since it decreases the number of involved processors. For the reasons outlined below, deriving a topology from a quaternary tree or any tree of arity greater than 4 worsen the parallel running time.

Can we further decrease the number of processors while conserving the running time stated in the theorem above? To do so, we should be able to increase the number of nodes or message blocks processed by one processor during one parallel step. Let us see a counter-example. Suppose that

we have a hash tree that can be processed in a parallel running time of $\lceil \log_2 l \rceil + 1$ and that one node in this tree has more than 3 leaves, say x leaves. We have $\lceil \log_2 x \rceil + 1 < x$ when $x > 3$, meaning that we can transform this node in order to improve the overall running time.

Theorem 3. *Let l be the number of blocks of the message and let i be the biggest integer such that $2^i < l$. The optimal parallel running time can be reached using only $\lceil l/3 \rceil$ processors if $2^i < l \leq 3 \cdot 2^{i-1}$ and $\lceil l/2 \rceil$ processors if $3 \cdot 2^{i-1} < l \leq 2^{i+1}$.*

PROOF. We just allow the derived tree (in the proof above) to have 3 leaves per node, instead of 2. We recall that the parallel running time is $\lceil \log_2(l/2) \rceil + 2$ with 2 leaves per node, whereas it is $\lceil \log_2(l/3) \rceil + 3$ using 3 leaves per node. If we have $\lceil \log_2(l/3) \rceil + 3 \leq \lceil \log_2(l/2) \rceil + 2$ for a given l , the second tree structure should be used to decrease the number of processors to $\lceil l/3 \rceil$. We now determine the range of values of l for which $\lceil \log_2(l/3) \rceil + 2 \leq \lceil \log_2 l \rceil$. Let us set $u = \log_2 l$. We rewrite the inequality $\lceil \log_2(l/3) \rceil + 2 \leq \lceil \log_2 l \rceil$ as

$$\lceil i + f - \log_2(3) + 2 \rceil \leq \lceil i + f \rceil \quad (1)$$

where f is the fractional part of u and i is its integer part. Since $2 - \log_2(3) > 0$, f is necessarily non-zero. Thus, Inequality (2) is satisfied iff $0 < f \leq \log_2 3 - 1$, *i.e.* iff $i < \log_2 l \leq i + \log_2(3/2)$. This leads to the expected intervals of validity.

Another question is the optimal parallel running time that can be obtained using a fixed number of processors.

Theorem 4. *Let l be the number of blocks of the message and let P be the number of processors. There exists a mode having an optimal parallel running time of $\lceil l/P \rceil + \lceil \log_2 P \rceil$ units of time.*

PROOF. Let us consider a message of $2P$ blocks. According to Theorem 5, it can be hashed in a parallel running time of $\lceil \log_2 2P \rceil + 1$ ($= \lceil \log_2 P \rceil + 2$) units of time. During the first two units of time, each processor processes 2 blocks of the message. We thus replace these 2 blocks by at most $\lceil l/P \rceil$ blocks that can

be hashed sequentially in at most $\lceil l/P \rceil$ units of time. Since there always exists two integers $a \geq 0$ and $b \geq 0$ such that $a + b = P$ and $a\lceil l/P \rceil + b\lfloor l/P \rfloor = l$, we conclude the result.

3.2. Case $d > 1$

Theorem 5. *Let a message of length l blocks. We can construct a hash tree allowing a parallel running time of exactly $\lceil \log_{(d+1)}(l/2) \rceil + 2$ units of time, using $\lceil l/2 \rceil$ processors.*

PROOF. First, we observe that $2(d+1)$ blocks of the message can be compressed in 3 units of times, using $d+1$ processors. Indeed, $d+1$ processors can each compress 2 blocks, and the first one can continue the evaluation of its hash function by processing the chaining values produced by the d other processors. Given a hash state, we can compress d subsequent chaining values in one unit of time. Thus, we can compress $d+1$ times more blocks (*i.e.* $3(d+1)^2$ in total) in one more unit of time, and by using $d+1$ times more processors. Repeating this recursively, we obtain a single chaining value (the root node) at an iteration k . It appears that k is the smallest integer satisfying the inequality $2(d+1)^k \geq l$. The total parallel running time then corresponds to the time required by the most loaded processor: the running time to process two blocks of the message, in addition to the running time to process at most dk chaining values, *i.e.* k units of time, yielding the expected result.

Note that $\forall d \geq 1 \forall x > 3$, we have $\lceil \log_{d+1}(x) - \log_{d+1}(2) \rceil + 2 < x$, meaning that more than 3 leaves per node lead to a suboptimal parallel time.

Theorem 6. *Let l be the number of blocks of the message and let i be the biggest integer such that $2(d+1)^i < l$. The optimal parallel running time can be reached using only $\lceil l/3 \rceil$ processors if $2(d+1)^i < l \leq 3(d+1)^i$ and $\lceil l/2 \rceil$ processors if $3(d+1)^i < l \leq 2(d+1)^{i+1}$.*

PROOF. A tree with 3 leaves per node is preferable if $\lceil \log_{(d+1)}(l/3) \rceil + 3 \leq \lceil \log_{(d+1)}(l/2) \rceil + 2$. We have to determine the range of values l which ful-

fill this inequality. Let us set $u = \log_{(d+1)}(l/2)$. We rewrite the inequality $\lceil \log_{(d+1)}(l/3) \rceil + 1 \leq \lceil \log_{(d+1)}(l/2) \rceil$ as

$$\lceil i + f + \log_{(d+1)}(2/3) + 1 \rceil \leq \lceil i + f \rceil \quad (2)$$

where f and i are respectively the fractional part and the integer part of u . Since $\log_{(d+1)}(2/3) + 1 > 0$ for all $d \geq 1$, f is necessarily non-zero. Thus, Inequality (2) is satisfied iff $0 < f \leq -\log_{(d+1)}(2/3)$, *i.e.* iff $i < \log_{(d+1)}(l/2) \leq i - \log_{(d+1)}(2/3)$. This leads to the expected intervals of validity.

Theorem 7. *Let l be the number of blocks of the message and let P be the number of processors. There exists a mode having an optimal parallel running time of at most $\lceil l/P \rceil + \lceil \log_{(d+1)}(P) \rceil$ units of time.*

PROOF. This theorem follows immediately from the previous one. We replace the size l by $2P$. This message is then compressed in $2 + \lceil \log_{(d+1)} P \rceil$ units of time. In this scheme, each processor starts by compressing two blocks of the message. If we replace these 2 blocks by $\lceil l/P \rceil$ blocks, this means that we can compress a message of at most $\lceil \frac{l}{P} \rceil P$ blocks in $\lceil l/P \rceil + \lceil \log_{(d+1)} P \rceil$ units of time. Since there always exists integers $a \geq 0$ and $b \geq 0$ such that $a + b = P$ and $a\lceil l/P \rceil + b\lfloor l/P \rfloor = l$, we conclude the result.

4. Concluding Remarks

Before looking at particular computing architectures, studying or designing parallel algorithms using a PRAM model is always the starting point to understand what will or will not be achievable. If we exclude the topic of arithmetic, parallel computing for cryptography has so far received little attention. In this paper, we gave exact complexity results for the case of cryptographic hashing. Namely, under a PRAM model, two cases were addressed: the *bounded parallelism case* where the parallel time depends on a fixed number of processors, and the *unbounded case* where both the parallel time and the number of processors depend solely on the message size. In particular, for this second case, exact

costs were derived when considering both a 2-level tree and a tree of unrestricted height.

As a future work, it would be appealing to see FPGA implementations of the treated cases along with their achievable throughputs. The *unbounded case* would be particularly interesting since the width of an implemented circuit is limited by the available number of logic cells. Two natural questions are then the maximal width supported by the high-end FPGA platforms and the monetary price per message size to obtain the lowest parallel time.

References

- [1] N. Ferguson, S. L. Bauhaus, B. Schneier, D. Whiting, M. Bellare, T. Kohno, J. Callas, J. Walker, The skein hash function family (version 1.2) (2009).
- [2] R. L. Rivest, B. Agre, D. V. Bailey, C. Crutchfield, Y. Dodis, K. Elliott, F. A. Khan, J. Krishnamurthy, Y. Lin, L. Reyzin, E. Shen, J. Sukha, D. Sutherland, E. Tromer, Y. L. Yin, The md6 hash function: A proposal to nist for sha-3 (2008).
- [3] M. Torgerson, R. Schroepel, T. Draelos, N. Dautenhahn, S. Malone, A. Walker, M. Collins, H. Orman, The sandstorm hash. submission to nist sha-3 competition (2008).
- [4] J.-P. Aumasson, S. Neves, Z. Wilcox-O’Hearn, C. Winnerlein, BLAKE2: Simpler, smaller, fast as MD5, in: Proceedings of the 11th International Conference on Applied Cryptography and Network Security, ACNS’13, Springer-Verlag, Berlin, Heidelberg, 2013, pp. 119–135.
- [5] J. Kelsey, S. jen Chang, R. Perlner, Special Publication 800-185. SHA-3 derived functions: cSHAKE, KMAC, TupleHash and Parallel-Hash, Tech. rep. (August 2016).
- [6] K. Atighehchi, R. Rolland, Optimization of tree modes for parallel hash functions: A case study, IEEE Transactions on Computers 66 (9) (2017) 1585–1598.

- [7] K. Atighehchi, R. Rolland, Optimization of tree modes for parallel hash functions, CoRR abs/1512.05864. arXiv:1512.05864.
URL <http://arxiv.org/abs/1512.05864>
- [8] K. Atighehchi, A. Bonnecaze, Asymptotic analysis of plausible tree hash modes for SHA-3, IACR Trans. Symmetric Cryptol. 2017 (4) (2017) 212–239.
- [9] B. Preneel, R. Govaerts, J. Vandewalle, Hash functions based on block ciphers: A synthetic approach, in: Proceedings of the 13th Annual International Cryptology Conference on Advances in Cryptology, CRYPTO'93, Springer-Verlag, London, UK, UK, 1994, pp. 368–378.
- [10] H. Kuwakado, M. Morii, Indifferentiability of single-block-length and rate-1 compression functions, IEICE Transactions 90-A (10) (2007) 2301–2308.
- [11] G. Bertoni, J. Daemen, M. Peeters, G. Van Assche, Sufficient conditions for sound tree and sequential hashing modes, Int. J. Inf. Secur. 13 (4) (2014) 335–353.
- [12] J. Coron, Y. Dodis, C. Malinaud, P. Puniya, Merkle-damgård revisited: How to construct a hash function, in: Advances in Cryptology - CRYPTO 2005: 25th Annual International Cryptology Conference, Santa Barbara, California, USA, August 14-18, 2005, Proceedings, 2005, pp. 430–448.
- [13] G. Bertoni, J. Daemen, M. Peeters, G. Van Assche, Keccak, Springer Berlin Heidelberg, Berlin, Heidelberg, 2013, pp. 313–314.
- [14] G. Bertoni, J. Daemen, M. Peeters, G. Van Assche, Sakura: A flexible coding for tree hashing, in: Applied Cryptography and Network Security, Vol. 8479 of Lecture Notes in Computer Science, Springer International Publishing, 2014, pp. 217–234.