

Potential theory and \mathbb{Z}^d -extensions

Damien THOMINE

Abstract

We study hitting probabilities for \mathbb{Z}^d -extensions of Gibbs-Markov maps. The goal is to estimate, given a finite $\Sigma \subset \mathbb{Z}^d$ and $p, q \in \Sigma$, the probability P_{pq} that the process starting from p returns to Σ at site q .

Our study generalizes the methods available for random walks. We are able to give in many settings (square integrable jumps, jumps in the basin of a Lévy or Cauchy random variable) asymptotics for the transition matrix $(P_{pq})_{p,q \in \Sigma}$ when the elements of Σ are far apart.

We use three main tools: a variant of the balayage identity using a transfer operator as a Markov transition kernel, a study inspired from fast-slow systems and the hitting time of small sets in hyperbolic systems to relate transfer operators and the transition matrices we seek to compute, and finally Fourier transform and perturbations of transfer operators *à la* Nagaev-Guivarc'h to effectively compute these transition matrices in an asymptotic regime.

Contents

Introduction	2
1 Setting and main results	5
1.1 Hitting probabilities for recurrent random walks	5
1.2 Dynamical systems: extension and induction	8
1.3 Gibbs-Markov maps	10
1.4 Shapes and matrices	12
1.5 Strategy and main results	16
2 From transition probabilities to potential	21
2.1 Cone contraction at time scale $\Theta(1)$	22
2.2 Product of matrices	25
2.3 Cone contraction at time scale $\Theta(\varepsilon^{-1})$	28
3 The ergodic case	36
3.1 Structure of extensions with non-mixing first return maps	37
3.2 End of the proof of Lemma 1.20	41
4 From potential to transition probabilities	44
4.1 Bootstrapping	45
4.2 Irreducibility of the bi-L-matrix	46

5	Fourier transform and perturbations of the transfer operator	48
5.1	Twisted Poisson equations	50
5.2	Transfer operators and periodicities	53
5.3	Fourier transform and twisted transfer operators	55
6	Computation of the potential operators	56
6.1	Computation of the potential: $d = 1$, square integrable jumps	57
6.2	Computation of the potential: $d = 1$, Lévy jumps	61
6.3	Computation of the potential: $d = 1$, Cauchy jumps	66
6.4	Computation of the potential: $d = 2$, square integrable jumps	71
A	Gibbs-Markov maps	74
A.1	Markov partitions and stopping times	74
A.2	Stopping times and regularizing effect of \mathcal{L}_φ	76
A.3	Induced Gibbs-Markov maps	77
	References	79

Introduction

Large classes of uniformly hyperbolic dynamical systems, when endowed with suitable probability measures, behave similarly to Markov chains. Many theorems pertaining to sequences of i.i.d. random variables have found generalizations for sequences of observables of such systems: the law of large numbers (Birkhoff's ergodic theorem), the central limit theorem [36, 47, 37, 22], the local central limit theorem and asymptotics of occupation times [11, 43, 1, 48, 16] and large deviation principles [38, 39, 53], to cite only the most widely known.

This article is part of a project to understand how an important part of the general theory of Markov processes, namely the probabilistic theory of potentials, can be adapted to dynamical systems. The specific problem we are interested in is inspired by the computation of *hitting probabilities for random walks*. Given a recurrent random walk $(S_n)_{n \geq 0}$ on \mathbb{Z}^d and a finite set $\Sigma \subset \mathbb{Z}^d$, one can compute the transition probabilities between points of Σ – in other words, the probability, given any $p, q \in \Sigma$, that a random walk starting from point p returns to Σ at point q .

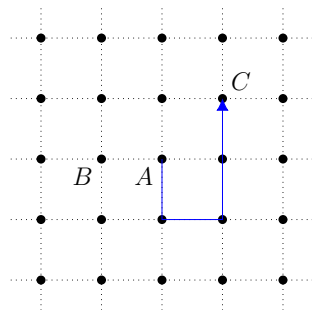

Figure 1: Three sites A, B, C in \mathbb{Z}^2 , and a transition from A to C .

This problem has an interpretation in terms of resistances in electrical networks, and may be solved using potential theory, more precisely the so-called *balayage identity* (see e.g. [45, Corol-

lary 1.11], or Theorem 1.1 below). With this method, for the simple random walk on \mathbb{Z}^2 and the subset $\Sigma = \{A, B, C\}$ of Figure 1, one finds that the matrix of transition probabilities is

$$P_{\{A,B,C\}} = \frac{1}{-\pi^2 + 8\pi - 4} \begin{pmatrix} -\frac{1}{2}\pi^2 + 4\pi - 4 & -\frac{1}{2}\pi^2 + 3\pi & \pi \\ -\frac{1}{2}\pi^2 + 3\pi & -\pi^2 + 6\pi - 4 & \frac{1}{2}\pi^2 - \pi \\ \pi & \frac{1}{2}\pi^2 - \pi & -\frac{3}{2}\pi^2 + 8\pi - 4 \end{pmatrix}. \quad (0.1)$$

A natural generalization of random walks is the class of \mathbb{Z}^d -extensions of dynamical systems. Starting from a probability-preserving ergodic dynamical system (A, μ, T) and a jump function $F : A \rightarrow \mathbb{Z}^d$, its \mathbb{Z}^d -extension is the system $([\mathbb{Z}^d], \tilde{\mu}, \tilde{T})$ defined by:

- State space: $[\mathbb{Z}^d] := A \times \mathbb{Z}^d$;
- Measure: $\tilde{\mu} := \mu \otimes \sum_{p \in \mathbb{Z}^d} \delta_p$;
- Transformation: $\tilde{T}(x, p) := (T(x), p + F(x)) \in [\mathbb{Z}^d]$ for all $(x, p) \in [\mathbb{Z}^d]$.

This class of systems include \mathbb{Z}^d -valued random walks, \mathbb{Z}^d -extensions of Markov chains [31, 32, 33] (sometimes used as toy models for more realistic processes), \mathbb{Z}^d -extensions of subshifts of finite type [43] as well as the collision map for Lorentz gases [48, 49]. Using well-chosen sections, the study of the Lorentz gas flow or of the geodesic flow on Abelian covers of negatively curved compact manifolds may also be reduced to the study of such extensions [44, 16].

In the setting of \mathbb{Z}^d -extensions, the study of hitting probabilities can be transposed as follows. Given a finite subset $\Sigma \subset \mathbb{Z}^d$ and $p, q \in \Sigma$, what is the probability (under μ) that the trajectory $(\tilde{T}^n(x, p))_{n \geq 0}$ returns to $A \times \Sigma$ at the site $A \times \{q\}$?

While an explicit computation of the matrix of transition probabilities, as in Equation (0.1), was possible for the simple random walk, such an explicit formula seems to be out of reach for more general dynamical systems. As for the central limit theorem, the local central limit theorem or the principle of large deviations, elementary formulas are available in an asymptotic regime. For hitting probabilities, we propose to study the asymptotics of the transition probabilities for families $(\Sigma_t)_{t > 0}$ of subsets of \mathbb{Z}^d whose points get farther and farther apart when the parameter t goes to infinity:

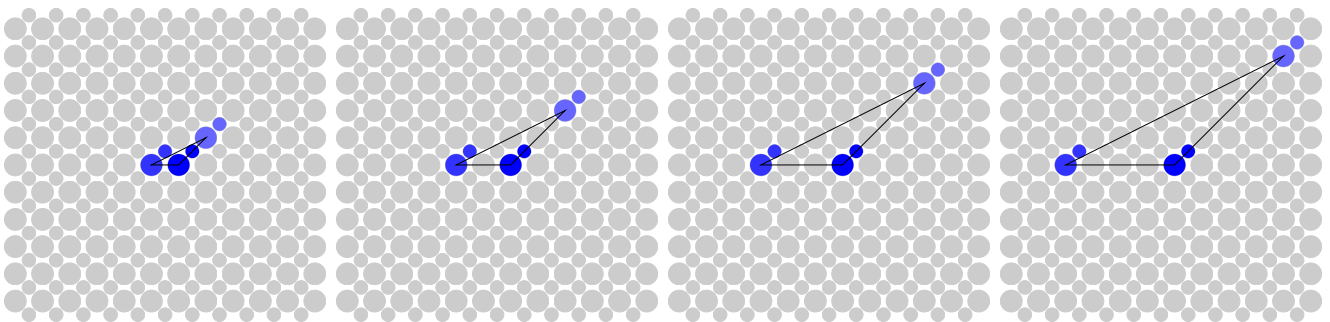

Figure 2: Some elements of a family of subset $(A \times \Sigma_t)_{t > 0}$ growing farther apart while keeping the same shape.

One particularly interesting case, pictured in Figure 2, occurs when those points keep the same shape, that is

$$\Sigma_t = \{t\sigma(i) + o(t) : i \in I\}$$

for some finite set I and some injective function $\sigma : I \rightarrow \mathbb{R}^d$. This kind of limit theorems is in line with a few former studies [32, 40].

In this setting, hitting probabilities could be obtained in [40] for families of subsets of size 2. However, these results were byproducts of distributional limit theorems for additive functionals of the process $(\tilde{T}^n)_{n \geq 0}$. As a consequence, the methods involved were extremely heavy, limited in scope as they could not produce the matrix of transition probabilities but only its symmetrization, and obscured the underlying potential theory. A second article [41] laid down the foundation for the use of probabilistic potential theory for hyperbolic dynamical systems; in particular, we need to use the transfer operator as a Markov operator instead of the Koopman operator.

The current contribution has two main parts. First, parametrizing by $\varepsilon = t^{-1}$ instead of t , we define *potential operators* $(Q_\varepsilon)_{\varepsilon > 0}$ acting on Lipschitz functions on $A \times \Sigma_\varepsilon$. We are able to relate these potential operators to the matrices of transition probabilities when ε vanishes:

Theorem 0.1.

Let $([\mathbb{Z}^d], \tilde{\mu}, \tilde{T})$ be an ergodic and recurrent Markov \mathbb{Z}^d -extension of a Gibbs-Markov map. Let I be finite. For $\varepsilon > 0$, let $\sigma_\varepsilon : I \hookrightarrow \mathbb{Z}^d$. Let P_ε be the matrix of transition probabilities on Σ_ε .

The following properties are equivalent:

- *there exists an irreducible (in the sense of Definition 1.8) bi-L-matrix R such that $P_\varepsilon = \text{Id} - \varepsilon R + o(\varepsilon)$;*
- *there exists an irreducible (in the sense of Definition 1.13) matrix S such that $Q_\varepsilon = \varepsilon^{-1} S + o(\varepsilon^{-1})$.*

If any of these properties holds, then, in addition, $S = R_0^{-1}$.

One of the main features of this theorem is that its hypotheses are quite general: recurrence is necessary for P_ε to be a stochastic matrix, while ergodicity ensures (among other things) that P_ε is irreducible. No assumption is made on the shape of the subsets $(\Sigma_\varepsilon)_{\varepsilon > 0}$ nor on the jumps F . Note that, for random walks, we have $Q_\varepsilon = (\text{Id} - P_\varepsilon)^{-1}$, so that the conclusion of Theorem 0.1 then holds even in the non-asymptotic regime.

The proof of Theorem 0.1 relies on the theory of *hitting time of small targets* [42, 26, 9, 6]: when ε vanishes, the transitions between different sites of $A \times \Sigma_\varepsilon$ become rare events¹, so the process induced by $(\tilde{T}^n)_{n \geq 0}$ looks like a Markov process on Σ_ε with transitions at times of order ε^{-1} . We give a probabilistic proof of Theorem 0.1, inspired by previous works on fast-slow systems [9, 12] and using a coupling argument to control these transitions. Note however, that a more analytic approach could be possible, along the line adopted by G. Keller and C. Liverani [29], or by D. Dolgopyat and P. Wright [17] (the later work being closer to our setting, as the operators involved have a degeneracy of higher order than those studied in [29]).

The potential operators $(Q_\varepsilon)_{\varepsilon > 0}$ can be estimated, in the asymptotic regime $\varepsilon \rightarrow 0$, from the perturbations of the main eigenvalue of the transfer operator associated with (A, μ, T) . When the jump function F is well-behaved, we get explicit expressions for the operator S in Theorem 0.1, and from there, a first order expansion of the transition matrices $(P_\varepsilon)_{\varepsilon > 0}$. We investigate four cases, when $d = 1$ and F is in the basin of attraction of a Lévy stable distribution (distinguishing the \mathbb{L}^2 , general Lévy and Cauchy cases), and when $d = 2$ and F is square integrable. For instance, in the later case, we get

¹This point of view explains the use of the parameter ε , which is the size of the targets, instead of t , for most of this article.

Proposition 0.2.

Let $([\mathbb{Z}^2], \tilde{\mu}, \tilde{T})$ be an ergodic and recurrent Markov \mathbb{Z}^2 -extension of a Gibbs-Markov map (A, μ, T) with jump function $F : A \rightarrow \mathbb{Z}^2$. Assume furthermore that $\|F\| \in \mathbb{L}^2(A, \mu)$. Let $\text{Cov} > 0$ be that asymptotic covariance matrix of F defined by Equation (6.14).

Let I be non-empty and finite and $\sigma : I \hookrightarrow \mathbb{R}^2$ be injective. For $t > 0$, let $\sigma_t : I \hookrightarrow \mathbb{Z}^2$ be such that $\sigma_t(i) = t\sigma(i) + o(t)$ for all $i \in I$. Let P_t be the transition matrix of the Markov chain induced on $\Sigma_t := \sigma_t(I)$. Then

$$P_t =_{t \rightarrow +\infty} \text{Id} - \frac{\pi \sqrt{\det(\text{Cov})}}{\ln(t)} R + o(\ln(t)^{-1}),$$

where R is the irreducible, symmetric bi-L-matrix defined by Equation (6.12):

$$\begin{cases} R_{ij} &= -\frac{1}{|I|} & \text{whenever } i \neq j \in I, \\ R_{ii} &= \frac{|I|-1}{|I|} & \forall i \in I. \end{cases}$$

This text also includes a few results which may be of independent interest, such as a structural result on the periodic components of a \mathbb{Z}^d -extension of a Gibbs-Markov map, which has the curious particularity of being different for \mathbb{Z} and \mathbb{Z}^2 -extensions (see Proposition 3.3).

The structure of this article is as follows. Section 1 is an introduction. We present a general method to compute transition matrices for random walks, ours setting (\mathbb{Z}^d -extensions, induced systems, Gibbs-Markov maps and transfer operators), and give our strategy to get ours results. Sections 2, 3 and 4 give a proof of Theorem 0.1; this decomposition in three steps shall be explained in Sub-subsection 1.5.3. Afterwards, we shall obtain Proposition 0.2 and similar propositions in Sections 5 and 6; the former will give a general formula for the potential operator Q_ε using Fourier transform, while the later will apply this formula to various settings. Finally, an appendix compiles some technical results on Gibbs-Markov maps.

Acknowledgements

The authors thanks Françoise Pène for the useful discussions while working on this project and her comments on the current version of this article.

1 Setting and main results

1.1 Hitting probabilities for recurrent random walks

1.1.1 General theory

Consider a sequence of independent and identically distributed \mathbb{Z}^d -valued random variables $(X_n)_{n \geq 0}$, and set $S_n := \sum_{k=0}^{n-1} X_k$. The sequence of random variables $(S_n)_{n \geq 0}$ is a random walk in \mathbb{Z}^d starting from 0. Let P be its transition kernel:

$$P_{pq} = \mathbb{P}(X_0 = q - p).$$

This transition kernel acts on functions by $P(f)(p) = \sum_{q \in \mathbb{Z}^d} P_{pq} f(q)$.

In what follows, we shall assume that $(S_n)_{n \geq 0}$ is recurrent and ergodic, which implies in particular that $d \in \{1, 2\}$. Given $\Sigma \subset \mathbb{Z}^d$ and $p \in \mathbb{Z}^d \setminus \Sigma$, we define the hitting time of Σ as the random variable

$$\bar{\varphi}_\Sigma(p) := \inf\{n \geq 0 : p + S_n \in \Sigma\},$$

and the *hitting point* as $p + S_{\bar{\varphi}_\Sigma(p)} \in \Sigma$. Then, by recurrence, the hitting point is a Σ -valued random variable. Its distribution can be computed in the following way: given any bounded function $f : \Sigma \rightarrow \mathbb{R}$, extend it to a bounded function $g : \mathbb{Z}^d \rightarrow \mathbb{R}$ such that

$$\begin{cases} g(r) &= f(r) & \forall r \in \Sigma, \\ (\text{Id} - P)(g)(r) &= 0 & \forall r \in \mathbb{Z}^d \setminus \Sigma. \end{cases} \quad (1.1)$$

Then, by a martingale argument,

$$g(p) = \mathbb{E}(f(p + S_{\bar{\varphi}_\Sigma(p)}));$$

specializing e.g. to $f = \mathbf{1}_q$ for $q \in \Sigma$ gives in principle the distribution of the hitting point, as long as one is able to solve Equation (1.1).

In this article, we are interested in a slightly different problem: Σ is finite, and we want to understand transition probabilities; that is, the starting point p belongs to Σ , and we consider the *hitting time*

$$\varphi_\Sigma(p) := \inf\{n \geq 1 : p + S_n \in \Sigma\}.$$

The problem of computing transition probabilities can be reframed in the following way. Taking a trajectory $(S_n)_{n \geq 0}$ of the random walk and keeping only the times at which the random walk belongs to Σ yields, by the strong Markov property, a Σ -valued *induced Markov chain*.

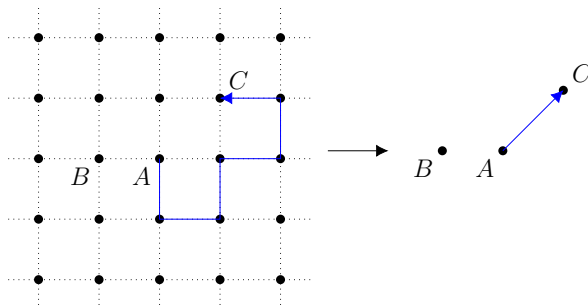

Figure 3: A transition on $\{A, B, C\}$ induced by a path in \mathbb{Z}^2 .

This induced Markov chain has transition matrix

$$P_{\Sigma, pq} = \mathbb{P}(p + S_{\varphi_\Sigma(p)} = q),$$

and we want to compute the operator P_Σ . This can be done thanks to a variation of Equation (1.1) adapted to starting points belonging to Σ , the so-called *balayage identity*. The version we quote is close to [45, Corollary 1.11], and can be found in [41]:

Theorem 1.1 (Balayage identity).

Let Ω be a Polish space, P a Markov kernel on Ω , and μ a measure which is stationary, recurrent and ergodic for P .

Let $\Sigma \subset \Omega$ be measurable, with $\mu(\Sigma) > 0$. Let $g \in \mathbb{L}^\infty(\Omega, \mu)$ and $f \in \mathbb{L}^\infty(\Sigma, \mu|_\Sigma)$. Let $f\mathbf{1}_\Sigma : \mathbb{Z}^d \rightarrow \mathbb{C}$ be the function which coincides with f on Σ and is null everywhere else.

If

$$(\text{Id} - P)g = f\mathbf{1}_\Sigma,$$

then:

$$(\text{Id} - P_\Sigma)g|_\Sigma = f.$$

Theorem 1.1 relates the solution of the Poisson equation for the kernel P on \mathbb{Z}^d to the solutions of the Poisson equation for the kernel P_Σ on Σ . In the framework of electrodynamics, f is an intensity, while g is an associated potential.

A first remark is that $(S_n)_{n \geq 0}$, seen as a Markov chain on \mathbb{Z}^d , preserves the counting measure, is ergodic and recurrent. Moreover, for general recurrent Markov chains with stationary measure μ , the restricted measure $\mu|_\Sigma$ is stationary for the Markov chain induced on Σ . Consequently, in the context of random walks, P_Σ preserves the uniform measure μ_Σ on Σ .

When acting on functions, P_Σ preserves constant functions. Since $(S_n)_{n \geq 0}$ is ergodic, so is P_Σ , so $\text{Ker}(\text{Id} - P_\Sigma) = \text{Vect}(\mathbf{1})$ has dimension 1. Finally, since P_Σ preserves μ_Σ , the eigenprojection onto $\text{Vect}(\mathbf{1})$ is given by $f \mapsto \mu_\Sigma(f)\mathbf{1}$, whence we have a P_Σ -invariant splitting $\mathbb{C}^\Sigma = \text{Vect}(\mathbf{1}) \oplus \mathbb{C}_0^\Sigma$, with $\mathbb{C}_0^\Sigma := \text{Ker}(\mu_\Sigma)$. Hence, all we need is to understand the action of P_Σ on \mathbb{C}_0^Σ .

Now, take any $f \in \mathbb{C}_0^\Sigma$. Extend it to $f\mathbf{1}_\Sigma : \mathbb{Z}^d \rightarrow \mathbb{C}$. Find a function $g : \mathbb{Z}^d \rightarrow \mathbb{C}$ such that $(\text{Id} - P)g = f\mathbf{1}_\Sigma$ and $\mu|_\Sigma(g) = 0$; such a function always exists under our hypotheses. Then $g|_\Sigma \in \mathbb{C}_0^\Sigma$ and $(\text{Id} - P_\Sigma)g|_\Sigma = f$ by the balayage identity. Doing this operation for all f in a basis of \mathbb{C}_0^Σ allows us, in theory, to compute the operator $(\text{Id} - P_\Sigma)^{-1}$ on \mathbb{C}_0^Σ . Then, invert $(\text{Id} - P_\Sigma)^{-1}$, and from there get the action of P_Σ on \mathbb{C}_0^Σ .

All is left is to effectively compute g given f . At this point the algebraic structure of the random walk plays a role, as we can use the Fourier transform. The main idea is that the operator \widehat{P} , which corresponds to the action of P in the frequency domain, is merely the multiplication operator by the characteristic function $\Psi(\xi) := \mathbb{E}(e^{i\langle \xi, X \rangle})$ of X . Up to an additive constant,

$$\widehat{g}(\xi) = \sum_{n=0}^{+\infty} \widehat{P}^n(\xi) \widehat{f}(\xi) = \sum_{n=0}^{+\infty} \Psi(\xi)^n \widehat{f}(\xi) = \frac{\widehat{f}(\xi)}{1 - \Psi(\xi)},$$

whence, writing $\mathbb{T}^d = \mathbb{R}^d / \mathbb{Z}^d$,

$$g(p) = \frac{1}{(2\pi)^d} \int_{\mathbb{T}^d} \frac{\widehat{f}(\xi)}{1 - \Psi(\xi)} e^{i\langle \xi, p \rangle} d\xi, \quad (1.2)$$

still up to an additive constant. If the kernel P is nice enough, as is the case for the simple random walk on \mathbb{Z}^d , such integrals can even be explicitly computed.

To sum up, this strategy to compute the Markov kernel P_Σ has three main ingredients:

- the balayage identity (Theorem 1.1) which relates the Markov kernels P and P_Σ through the solutions to their respective Poisson equations;
- the ability to solve the Poisson equation on \mathbb{Z}^d , using for instance the Fourier transform;
- the ability to invert $(\text{Id} - P_\Sigma)^{-1}$.

In the case of random walks, \mathbb{C}_0^Σ is finite dimensional, so the last step may seem comparatively insignificant. However, in the remainder of this article, we shall work with operators acting on infinite-dimensional Banach spaces, for which getting explicit information on their inverse is much tougher.

1.1.2 An example with the simple random walk

Now, let us delve deeper into the method described in Sub-subsection 1.1.1 by applying it to the example of Figure 1. We take for $(S_n)_{n \geq 0}$ the simple random walk on \mathbb{Z}^2 , and $\Sigma = \{A, B, C\}$ with $A = (0; 0)$, $B = (-1; 0)$ and $C = (1; 1)$.

The simple random walk has a transition kernel $P_p = \frac{1}{4} \sum_{q \leftrightarrow p} \delta_q$, where $q \leftrightarrow p$ if and only if p and q are neighbours. Its action on functions $f : \mathbb{Z}^2 \rightarrow \mathbb{C}$ is thus

$$P(f)(p) = \frac{1}{4} \sum_{q \leftrightarrow p} f(q),$$

and the simple random walk is indeed ergodic, recurrent, and preserves the counting measure on \mathbb{Z}^2 .

Let P_Σ be the transition matrix for the Markov chain induced on Σ . Then P_Σ preserves the uniform measure on Σ denoted by μ_Σ . Thus we have a P_Σ -invariant splitting $\mathbb{C}^\Sigma = \text{Ker}(\mu_\Sigma) \oplus \text{Vect}(\mathbf{1})$.

Now, we need to understand the action of P_Σ on $\text{Ker}(\mu_\Sigma) = \mathbb{C}_0^\Sigma$. It is enough to understand its action on a basis, say, $e_1 := \mathbf{1}_A - \mathbf{1}_B$ and $e_2 := \mathbf{1}_A - \mathbf{1}_C$. Note however that Equation (1.2) only let us compute $(\text{Id} - P_\Sigma)^{-1} e_j$ up to an additive constant. To sidestep this issue, we compute the quantities

$$\langle e_i, (\text{Id} - P_\Sigma)^{-1} e_j \rangle_{\ell^2(\Sigma)} := \sum_{p \in \Sigma} e_i(p) \cdot [(\text{Id} - P_\Sigma)^{-1} e_j](p)$$

for $i, j \in \{1, 2\}$, which is enough to reconstruct the action of $(\text{Id} - P_\Sigma)^{-1}$ on \mathbb{C}_0^Σ . Since all the e_i are in \mathbb{C}_0^Σ , the indetermination of $(\text{Id} - P_\Sigma)^{-1}$ up to constants does not matter. We illustrate this computation with $i = j = 1$. By Theorem 1.1,

$$\begin{aligned} \langle e_1, (\text{Id} - P_\Sigma)^{-1} e_1 \rangle_{\ell^2(\Sigma)} &= \sum_{p \in \Sigma} e_1(p) \cdot [(\text{Id} - P_\Sigma)^{-1} e_1](p) \\ &= \sum_{p \in \mathbb{Z}^2} (e_1 \mathbf{1}_\Sigma)(p) \cdot [(\text{Id} - P)^{-1} (e_1 \mathbf{1}_\Sigma)](p) \\ &= \frac{1}{(2\pi)^2} \int_{\mathbb{T}^2} (\widehat{\mathbf{1}_A - \mathbf{1}_B})(-\xi) \cdot \frac{(\widehat{\mathbf{1}_A - \mathbf{1}_B})(\xi)}{1 - \Psi(\xi)} d\xi \\ &= \frac{1}{(2\pi)^2} \int_{\mathbb{T}^2} (1 - e^{-i\xi_1}) \cdot \frac{(1 - e^{i\xi_1})}{1 - \frac{e^{i\xi_1} + e^{-i\xi_1} + e^{i\xi_2} + e^{-i\xi_2}}{4}} d\xi \\ &= \frac{1}{\pi^2} \int_{\mathbb{T}^2} \frac{1 - \cos(\xi_1)}{2 - \cos(\xi_1) - \cos(\xi_2)} d\xi \\ &= 2. \end{aligned}$$

The other three computations are similar. We recover from there the action of $(\text{Id} - P_\Sigma)^{-1}$ on \mathbb{C}_0^Σ , then the action on P_Σ on \mathbb{C}_0^Σ after inversion. Finally, adding the rank one map $\mathbf{1} \otimes \mu_\Sigma$ yields the matrix of Equation (0.1).

1.2 Dynamical systems: extension and induction

1.2.1 \mathbb{Z}^d -extensions of dynamical systems

A common generalization of random walks on \mathbb{Z}^d , in the context of ergodic theory, is that of \mathbb{Z}^d -extension. Let (A, μ, T) be a probability-preserving dynamical system, and $F : A \rightarrow \mathbb{Z}^d$ a measurable

function (which we call the *jump function*). Let $([\mathbb{Z}^d], \tilde{\mu}, \tilde{T})$ be the corresponding \mathbb{Z}^d -extension as defined at the beginning of this text.

Let us write $S_n F(x) := \sum_{k=0}^{n-1} F(T^k(x))$ the Birkhoff sums of F . Then

$$\tilde{T}^n(x, p) = (T^n(x), p + S_n F(x)).$$

This setting includes random walks: take $A = (\mathbb{Z}^d)^{\mathbb{N}}$, then $T((x_n)_{n \geq 0}) = (x_{n+1})_{n \geq 0}$ and $\mu = \mu_0^{\otimes \mathbb{N}}$ a product measure on A . Choose $F((x_n)_{n \geq 0}) = x_0$; then, under $\mu \otimes \nu \in \mathcal{P}([\mathbb{Z}^d])$, the second coordinate is a random walk whose starting point has distribution ν and whose jumps have distribution μ_0 . If one replaces the full shift by a subshift, or take a Markov measure instead of the product measure, we get a *random walk with internal states*, which is a special case of hidden Markov models [31, 32, 33]. If (A, μ, T) is the collision map of a Sinai billiard, then $([\mathbb{Z}^d], \tilde{\mu}, \tilde{T})$ is the collision map of a Lorentz gas, a popular diffusion model.

1.2.2 Inductions of dynamical systems

Let (B, ν, S) be a measure-preserving dynamical system. For any measurable $C \subset B$ with positive measure, we define the *first hitting time* of C as:

$$\varphi_C(x) := \inf\{n \geq 1 : \tilde{T}^n(x) \in C\}.$$

The system (B, ν, S) is said to be ergodic if it has no non-trivial strictly invariant subset, and *recurrent* if $\varphi_C(x) < +\infty$ for almost every $x \in C$, for any measurable $C \subset [Z^d]$.

If (B, ν, S) is recurrent and $C \subset B$ has positive measure, the *induced map*

$$T_C : \begin{cases} C & \rightarrow C \\ x & \mapsto \tilde{T}^{\varphi_C(x)}(x) \end{cases}$$

is well-defined almost everywhere, recurrent, and preserves the restricted measure $\nu_C := \nu|_C$ [41, Corollary 1.1]. If in addition (B, ν, S) is ergodic, then so is (C, ν_C, T_C) . In what follows, we shall often make this assumption:

Hypothesis 1.2 (Recurrence).

The \mathbb{Z}^d -extension $([\mathbb{Z}^d], \tilde{\mu}, \tilde{T})$ is ergodic and recurrent.

Let $([\mathbb{Z}^d], \tilde{\mu}, \tilde{T})$ be a recurrent \mathbb{Z}^d -extension. For any $\Sigma \subset \mathbb{Z}^d$, we shall write $[\Sigma] := A \times \Sigma \subset [\mathbb{Z}^d]$. If $\Sigma = \{\sigma\}$ is a singleton, we shall dispense with the brackets, and write $[p] = A \times \{p\}$. In this article, we will work with three types of systems:

- the initial probability-preserving dynamical system (A, μ, T) ;
- a \mathbb{Z}^d -extension $([\mathbb{Z}^d], \tilde{\mu}, \tilde{T})$ with jump function F ;
- induced maps $([\Sigma], \mu_{[\Sigma]}, T_{[\Sigma]})$ for $\Sigma \subset \mathbb{Z}^d$.

We try as much as possible to keep our notations coherent: objects with a tilde refer to the \mathbb{Z}^d -extension, and objects with a set as an index refer to induced maps.

In this context, we define transition probabilities as follows:

Definition 1.3 (Transition probabilities).

Let $([\mathbb{Z}^d], \tilde{\mu}, \tilde{T})$ be a recurrent \mathbb{Z}^d -extension of a dynamical system (A, μ, T) . Let $\Sigma \subset \mathbb{Z}^d$ be finite. The matrix of transition probabilities P_Σ is defined by:

$$P_{\Sigma,pq} := \mu(x \in A : T_{[\Sigma]}(x,p) \in [q]).$$

As long as the extension is recurrent, the matrix P_Σ is *bi-stochastic*: the sum of each of its rows and of each of its columns is 1.

Lemma 1.4.

Let $([\mathbb{Z}^d], \tilde{\mu}, \tilde{T})$ be a recurrent \mathbb{Z}^d -extension of a probability preserving dynamical system. Let $\Sigma \subset \mathbb{Z}^d$ be non-empty. Then P_Σ is bi-stochastic.

Proof. The fact that P_Σ is stochastic is a translation of the fact that \tilde{T} is recurrent. For any $p \in \Sigma$,

$$\begin{aligned} \sum_{q \in \Sigma} P_{\Sigma,pq} &= \sum_{q \in \Sigma} \mu(x \in A : T_{[\Sigma]}(x,p) \in [q]) \\ &= \mu(x \in A : T_{[\Sigma]}(x,p) \in [\Sigma]) \\ &= \tilde{\mu}([p] \cap \{\varphi_{[\Sigma]} < +\infty\}) \\ &= 1. \end{aligned}$$

The bi-stochasticity of P_Σ comes from the fact that $T_{[\Sigma]}$ preserves $\mu_{[\Sigma]}$. For any $q \in \Sigma$,

$$\begin{aligned} \sum_{p \in \Sigma} P_{\Sigma,pq} &= \sum_{p \in \Sigma} \mu(x \in A : T_{[\Sigma]}(x,p) \in [q]) \\ &= \mu_{[\Sigma]}(T_{[\Sigma]}^{-1}([q])) \\ &= \mu_{[\Sigma]}([q]) \\ &= 1. \end{aligned}$$

□

1.3 Gibbs-Markov maps

If no assumption is made on (A, μ, T) nor on F , the behaviour of the trajectories of the system $([\mathbb{Z}^d], \tilde{\mu}, \tilde{T})$ can be extremely diverse: for instance, the rate of diffusion in Ehrenfest's wind-tree model depends on the geometry of the scatterers [14, 19]. However, if (A, μ, T) is in some sense chaotic and F regular, the trajectories of the system $([\mathbb{Z}^d], \tilde{\mu}, \tilde{T})$ will be very similar to random walks on \mathbb{Z}^d .

In this article, we choose to work with Gibbs-Markov maps. This family of transformations is Markovian, which brings the benefits of avatars of the strong Markov property, for instance Corollary A.7. These transformations are still flexible enough to give rise to a wide variety of examples and, using Young's construction [54], they appear in many geometric examples such as the geodesic flow on negatively curved manifolds, finite horizon Sinai billiards, and Collet-Eckmann unimodal transformations.

The family of \mathbb{Z}^d -extensions we get is much more general than random walks and random walks with internal states as in [32, 33], while still more restrictive than Sinai billiards or unimodal maps, since we do not work with Young towers.

1.3.1 Definition

In what follows, we shall assume that (A, μ, T) is a *Gibbs-Markov map*:

Definition 1.5 (Measure-preserving Gibbs-Markov maps).

Let (A, d') be a metric bounded Polish space, \mathcal{A} its Borel σ -algebra and μ a probability measure on (A, \mathcal{A}) . Let α be a partition of A in subsets of positive measure (up to a null set). Let $T : A \rightarrow A$ be a μ -preserving map, Markov with respect to the partition α , and such that α is generating. Such a map is said to be Gibbs-Markov if it also satisfies:

- *Big image property*: $\inf_{a \in \alpha} \mu(Ta) > 0$;
- *Expansivity*: there exists $\Lambda > 1$ such that $d'(Tx, Ty) \geq \Lambda d(x, y)$ for all $a \in \alpha$ and $(x, y) \in a \times a$;
- *Bounded distortion*: there exists $C > 0$ such that, for all $a \in \alpha$, for almost every $(x, y) \in a \times a$:

$$\left| \frac{d\mu}{d\mu \circ T}(x) - \frac{d\mu}{d\mu \circ T}(y) \right| \leq C d'(Tx, Ty) \frac{d\mu}{d\mu \circ T}(x). \quad (1.3)$$

Given a Gibbs-Markov map (A, α, d', μ, T) , a function $F : A \rightarrow \mathbb{Z}^d$ is said to be *Markov* if it is constant on elements of the partition α . In this case, we also say that the corresponding \mathbb{Z}^d -extension $([\mathbb{Z}^d], \tilde{\mu}, \tilde{T})$ is Markov.

By encoding, Gibbs-Markov maps can model sequences of independent and identically distributed \mathbb{Z}^d -valued random variables, as well as finite state Markov chains. As such, Markov extensions of Gibbs-Markov maps include all random walks, with or without internal states, on \mathbb{Z}^d . They are however more general, including for instance the Gauss maps

$$T : \begin{cases} (0, 1] & \rightarrow [0, 1] \\ x & \mapsto 1/x - \lfloor 1/x \rfloor \end{cases},$$

and appear in various encoding schemes used to study geodesic flows in negative sectional curvature as well as Sinai billiards.

A comprehensive presentation of the properties of Gibbs-Markov maps we use in this article can be found in Appendix A, in particular their properties related to the extension and induction operations described in Subsection 1.2.

1.3.2 Transfer operators

One of our main tools is the *transfer operator* \mathcal{L} , defined as the dual of the composition (or Koopman) operator $\mathcal{K} : g \mapsto g \circ T$:

$$\int_A \mathcal{L}(f) \cdot g \, d\mu := \int_A f \cdot g \circ T \, d\mu, \quad (1.4)$$

for all $p \in [1, \infty]$, all $f \in \mathbb{L}^p(A, \mu; \mathbb{C})$ and all $g \in \mathbb{L}^q(A, \mu; \mathbb{C})$, with $p^{-1} + q^{-1} = 1$. Since the Koopman operator is an isometry on \mathbb{L}^q , the transfer operator is a weak contraction on \mathbb{L}^p .

As specified in Sub-subsection 1.2.2, the operator \mathcal{L} acts on $\mathbb{L}^p(A, \mu; \mathbb{C})$, the operator $\tilde{\mathcal{L}}$ on $\mathbb{L}^p([\mathbb{Z}^d], \tilde{\mu}; \mathbb{C})$ and the operator $\mathcal{L}_{[\Sigma]}$ on $\mathbb{L}^p([\Sigma], \mu_{[\Sigma]}; \mathbb{C})$.

One of the main feature of Gibbs-Markov maps is that the transfer operator acts quasi-compactly on a Banach space of Lipschitz functions. We present here the most important properties of the action; again, details and references can be found in Appendix A.

Definition 1.6 (Lipschitz functions).

Let $\alpha^* := \bigvee \{T(a) : a \in \alpha\}$ be the image partition² of α by T . The Lipschitz seminorm of a function $f : A \rightarrow \mathbb{C}$ is

$$|f|_{\mathcal{B}} := \sup_{a \in \alpha^*} |f|_{\text{Lip}(a, d')},$$

where $|f|_{\text{Lip}(a, d')}$ is the Lipschitz constant of f on a . The Lipschitz norm is then given by

$$\|f\|_{\mathcal{B}} := \|f\|_{\infty} + |f|_{\mathcal{B}},$$

and the space of Lipschitz functions \mathcal{B} by $\{f : A \rightarrow \mathbb{C}, \|f\|_{\mathcal{B}} < +\infty\}$.

Finally, we write \mathcal{B}_0 for the kernel of μ in \mathcal{B} .

A typical result (see [21, Proposition 1.1.17 and Corollary 1.1.21]) is then:

Theorem 1.7.

Let (A, α, d', μ, T) be a Gibbs-Markov map with expansivity constant $\Lambda > 1$. The transfer operator \mathcal{L} acts on \mathcal{B} , with essential spectral radius $\rho_{\text{ess}}(\mathcal{L} \curvearrowright \mathcal{B}) \leq \Lambda^{-1}$.

If (A, μ, T) is also mixing, then the spectral radius of $\mathcal{L} \curvearrowright \mathcal{B}_0$ is strictly less than 1: there exist constants $C > 0$ and $\rho \in (0, 1)$ such that $\|\mathcal{L}^n\|_{\mathcal{B}_0 \rightarrow \mathcal{B}_0} \leq C\rho^n$.

Another important feature of Gibbs-Markov maps is that they behave very well under induction. Let $([\mathbb{Z}^d], \tilde{\mu}, \tilde{T})$ be a recurrent and ergodic Markov \mathbb{Z}^d -extension of a Gibbs-Markov map, and $\Sigma \subset \mathbb{Z}^d$ be finite. Following the strategy of e.g. [51, Lemma 1.6], one may endow the system $([\Sigma], \mu_{[\Sigma]}, T_{[\Sigma]})$ with a Gibbs-Markov structure, with expansivity and distortion constants independent from Σ . From there one could get a family of Banach spaces depending on Σ . However, we shall not use directly this construction, but choose a closely related strategy: we make all the transfer operators $\mathcal{L}_{[\Sigma]}$ act on the same Banach space, with relevant bounds (such as the essential spectral radius) uniform in Σ . This let us compare more easily all the operators $\mathcal{L}_{[\Sigma]}$.

We associate to $([\Sigma], \mu_{[\Sigma]}, T_{[\Sigma]})$ a Banach space of Lipschitz functions

$$\mathcal{B}_{[\Sigma]} := \{f : [\Sigma] \rightarrow \mathbb{C}, f(\cdot, i) \in \mathcal{B} \forall i \in \Sigma\}, \quad (1.5)$$

endowed with the norm $\|f\|_{\mathcal{B}_{[\Sigma]}} = \max_{i \in I} \|f(\cdot, i)\|_{\mathcal{B}}$. We denote by $\mathcal{B}_{[\Sigma], 0}$ the kernel of $\mu_{[\Sigma]}$.

Not that the spaces $\mathcal{B}_{[\Sigma]}$ depend only on Σ through its cardinality: if two subsets Σ_1, Σ_2 have the same cardinality, then $\mathcal{B}_{[\Sigma_1]}$ and $\mathcal{B}_{[\Sigma_2]}$ are naturally isomorphic. By Proposition A.8, the operator $\mathcal{L}_{[\Sigma]}$ acts quasi-compactly on $\mathcal{B}_{[\Sigma]}$, with essential spectral radius at most Λ^{-1} . In particular, by ergodicity, 1 is a simple eigenvalue of $\mathcal{L}_{[\Sigma]}$ corresponding to constant functions, so that $(\text{Id} - \mathcal{L}_{[\Sigma]}) \curvearrowright \mathcal{B}_{[\Sigma], 0}$ is invertible.

1.4 Shapes and matrices

1.4.1 Limit shapes

As we argued in the introduction, it seems extremely hard to state anything non-trivial about the matrix of transition probabilities $P_{[\Sigma]}$ for any fixed Σ . Instead, we shall be interested in subsets Σ whose sites are very far apart. We formalize this by fixing a finite set I , considering a family

²In many applications, α^* is trivial – consider for instance the Gauss map, where any interval $((n+1)^{-1}, n^{-1}]$ is sent onto $[0, 1)$.

of injections $\sigma_\varepsilon : I \hookrightarrow \mathbb{Z}^d$ whose values get apart when ε vanishes, and looking at the matrix of transition probabilities of $[\Sigma_\varepsilon] := [\sigma_\varepsilon(I)]$.

A simple way of generating such functions σ_ε is to fix some injection $\sigma : I \hookrightarrow \mathbb{R}^d$, and to define $\sigma_\varepsilon(i)$ as one of the points of \mathbb{Z}^d closest to $\varepsilon^{-1}\sigma(i)$ – or, more generally, any point at distance $o(\varepsilon^{-1})$ of $\varepsilon^{-1}\sigma(i)$. As ε vanishes, the subsets $\Sigma_\varepsilon = \sigma_\varepsilon(I)$ become growing realizations of a fixed shape (see Figure 2).

For any $\varepsilon > 0$, there is a canonical bijection $\sigma_{\varepsilon*} : (x, i) \mapsto (x, \sigma_\varepsilon(i))$ between $[I] := A \times I$ and $[\Sigma_\varepsilon] = A \times \Sigma_\varepsilon$. We use this bijection to transport objects from $[\Sigma_\varepsilon]$ to $[I]$:

- $\mu_I := |I|^{-1} \sum_{i \in I} \mu \otimes \delta_i$ is conjugated with $\mu_{[\Sigma_\varepsilon]}$ and does not depend on ε ;
- $T_\varepsilon : [I] \rightarrow [I]$ is conjugated with $T_{[\Sigma_\varepsilon]}$;
- $\mathcal{L}_\varepsilon \curvearrowright \mathbb{L}^p([I], \mu_I)$ is conjugated with $\mathcal{L}_{[\Sigma_\varepsilon]} \curvearrowright \mathbb{L}^p([\Sigma], \mu_{[\Sigma]})$;
- \mathcal{B}_I is conjugated with $\mathcal{B}_{[\Sigma_\varepsilon]}$, and by definition does not depend on ε ;
- P_ε is conjugated with $P_{[\Sigma_\varepsilon]}$, etc.

The general rule is that objects defined on $[I]$ have I as a subscript if they do not depend on ε , and ε as a subscript if they do. This point of view allows us to keep some objects fixed (the space, the measure, the Banach space \mathcal{B}_I , and later on functions) while ε , and thus Σ_ε , changes.

1.4.2 Transfer operator and transition probabilities

The matrices $(P_\varepsilon)_{\varepsilon > 0}$ can be recovered from the Koopman operators $(\mathcal{K}_\varepsilon)_{\varepsilon > 0}$. Given $\varepsilon > 0$ and $i, j \in I$,

$$\begin{aligned} P_{\varepsilon, ij} &= \mu([i] \cap T_\varepsilon^{-1}([j])) \\ &= |I| \int_{[I]} \mathbf{1}_{[i]} \cdot \mathcal{K}_\varepsilon(\mathbf{1}_{[j]}) \, d\mu_I. \end{aligned} \tag{1.6}$$

Using transfer operators, this relationship can be rewritten

$$P_{\varepsilon, ij} = |I| \int_{[I]} \mathcal{L}_\varepsilon(\mathbf{1}_{[i]}) \cdot \mathbf{1}_{[j]} \, d\mu_I, \tag{1.7}$$

and made more systematic by introducing an averaging operator. Let:

$$\Pi_* : \begin{cases} \mathbb{L}^1([I], \mu_I) & \rightarrow \mathbb{C}^I \\ f & \mapsto \left(\int_A f(x, i) \, d\mu(x) \right)_{i \in I} \end{cases},$$

which to a function f associate its averages over each $[i]$, and define a right inverse Π^* of Π_* :

$$\Pi^* : \begin{cases} \mathbb{C}^I & \rightarrow \mathbb{L}^1([I], \mu_I) \\ f & \mapsto \sum_{i \in I} f_i \mathbf{1}_{[i]} \end{cases}.$$

The operators Π_* and Π^* satisfy the relation $\Pi_* \Pi^* = \text{Id}_{\mathbb{C}^I}$, while $\Pi^* \Pi_*$ is a rank $|I|$ averaging operator on $\mathbb{L}^1([I], \mu_I)$:

$$(\Pi^* \Pi_* f)(x, i) = \int_A f(y, i) \, d\mu(y).$$

Equations (1.6) and (1.7) can then be recast as

$$P_\varepsilon = \Pi_* \mathcal{K}_\varepsilon \Pi^* \text{ and } {}^t P_\varepsilon = \Pi_* \mathcal{L}_\varepsilon \Pi^*. \tag{1.8}$$

1.4.3 Asymptotics of the transition matrices and irreducibility

By [40, Lemma 3.17], if the minimal distance between distinct sites in Σ_ε increases to $+\infty$ when ε vanishes, then the transitions from one site to another becomes increasingly unlikely, so that $\lim_{\varepsilon \rightarrow 0} P_\varepsilon = \text{Id}$. In this article, we are interested in the next order asymptotics of the family $(P_\varepsilon)_{\varepsilon > 0}$ when ε vanishes. By Lemma 1.4, the matrices P_ε are bi-stochastic, so that the differences $(\text{Id} - P_\varepsilon)$ are what we shall call *bi-L-matrices*. In other words, up to a sign, bi-L-matrices make up the tangent cone at Id to the space of bi-stochastic matrices.

Definition 1.8 (L-matrix).

A L-matrix is a square matrix such that³:

- $R_{ii} \geq 0$ for all $i \in I$;
- $R_{ij} \leq 0$ for $i \neq j \in I$;
- $\sum_{j \in I} R_{ij} = 0$ for all $i \in I$.

We shall call a L-matrix a bi-L-matrix if, in addition, $\sum_{i \in I} R_{ij} = 0$ for all $j \in I$.

A L-matrix is irreducible if, for all $i, j \in I$, there exists a finite sequence $i = i_0, i_1, \dots, i_n = j$ such that $R_{i_k i_{k+1}} < 0$ for all $0 \leq k < n$.

Using Perron-Frobenius theory, eigenvalues of a L-matrix always have non-negative real part. For irreducible L-matrices, we can be more accurate.

Lemma 1.9.

Let R be a $n \times n$ irreducible L-matrix. Then:

- 0 is a simple eigenvalue of R with eigenfunction $\mathbf{1}$.
- there exists a unique probability vector ν such that $\nu R = 0$.
- the matrix R acts on $\text{Ker}(\nu)$, and $\text{Sp}(R \curvearrowright \text{Ker}(\nu)) \subset \{z \in \mathbb{C} : \Re(z) > 0\}$.

Proof. Let R be an irreducible L-matrix. Set $t := \max_i R_{ii}$. Then $\text{Id} - t^{-1}R$ is an irreducible non-negative matrix. The lemma follows from Perron-Frobenius theory applied to $\text{Id} - t^{-1}R$. \square

Let us write R_0 for the restriction of R to $\text{Ker}(\nu)$. A L-matrix R is never invertible. However, if R is also irreducible, then R_0 is invertible. Given an irreducible L-matrix R , we shall write

$$\rho_R := \min\{\Re(\lambda) : \lambda \in \text{Sp}(R \curvearrowright \text{Ker}(\nu))\} = \min\{\Re(\lambda) : \lambda \in \text{Sp}(R_0)\}.$$

We shall often assume that the family $(P_\varepsilon)_{\varepsilon > 0}$ admits a first order asymptotics at $\varepsilon = 0$.

Hypothesis 1.10 (Asymptotics of the transition matrices).

There exists an irreducible bi-L-matrix R such that

$$P_\varepsilon = \text{Id} - \varepsilon R + o(\varepsilon).$$

³The usual definition of L-matrix does not require that the sum of each line be zero.

1.4.4 Asymptotics of the potential and irreducibility

One issue with Hypothesis 1.10 is that we do not know *a priori* the matrices $(P_\varepsilon)_{\varepsilon>0}$; indeed, our goal is to compute them! As described in Subsection 1.1, what can be computed are potentials. We shall now define matrices related to these potential, as well as a related irreducibility condition.

Let $([\mathbb{Z}^d], \tilde{\mu}, \tilde{T})$ be a Markov \mathbb{Z}^d -extension satisfying Hypothesis 1.2. By the discussion at the very end of Sub-subsection 1.3.2, for any function $f \in \mathcal{B}_{I,0}$ and any $\varepsilon > 0$, there exists a unique function $g \in \mathcal{B}_{I,0}$, its associated potential, such that $(\text{Id} - \mathcal{L}_\varepsilon)g = f$.

Let $\langle \cdot, \cdot \rangle_{\ell^2(I)}$ be the canonical scalar – and not Hermitian – product on \mathbb{C}^I . In order to get a finite-dimensional version of $(\text{Id} - \mathcal{L}_\varepsilon)^{-1}$, we define an operator acting on $\mathbb{C}_0^I = \{f : I \rightarrow \mathbb{C}, \sum_{i \in I} f_i = 0\} = \text{Ker}(\mu_I)$ by:

$$\langle f, Q_\varepsilon(g) \rangle_{\ell^2(I)} := \langle \Pi_*(\text{Id} - \mathcal{L}_\varepsilon)^{-1} \Pi^*(f), g \rangle_{\ell^2(I)}$$

where the inverse $(\text{Id} - \mathcal{L}_\varepsilon)^{-1}$ is taken in $\mathcal{B}_{I,0}$. This operator is well-defined since $\Pi^*(\mathbb{C}_0^I) \subset \mathcal{B}_{I,0}$.

The operator Q_ε is characterized by the integrals:

$$\langle f, Q_\varepsilon(g) \rangle_{\ell^2(I)} = |I| \int_{[I]} (\text{Id} - \mathcal{L}_\varepsilon)^{-1} (\Pi^*(f)) \cdot \Pi^*(g) \, d\mu_I = |I| \langle (\text{Id} - \mathcal{L}_\varepsilon)^{-1} \Pi^*(f), \Pi^*(g) \rangle_{\mathbb{L}^2([I], \mu_I)}. \quad (1.9)$$

Remark 1.11.

Let us justify our choice of definition for Q_ε . We want to adapt the construction we have for Markov maps to dynamical systems, using the Koopman operator \mathcal{K}_ε instead of the Markov operator. Since the Koopman operator does not act well on function spaces, we introduce its dual, defined by Equation (1.4). The operator $\Pi_(\text{Id} - \mathcal{L}_\varepsilon)^{-1} \Pi^*$ is thus a discretization of the potential operator associated with the dual of \mathcal{K}_ε . We make it act on the left to cancel those dualities, so that the resulting operator Q_ε acts as a discretization of the potential operator associated with \mathcal{K}_ε .*

As we formulated asymptotics and irreducibility conditions for the family $(P_\varepsilon)_{\varepsilon>0}$, let us do so for the family $(Q_\varepsilon)_{\varepsilon>0}$.

Hypothesis 1.12 (Asymptotics of the potential matrices).

There exists a matrix S acting on \mathbb{C}_0^I such that

$$Q_\varepsilon = \varepsilon^{-1} S + o(\varepsilon^{-1}).$$

Definition 1.13 (Irreducible potentials).

A matrix S acting on \mathbb{C}_0^I is said to be irreducible if, for all $i \neq j \in I$,

$$\langle (\mathbf{1}_i - \mathbf{1}_j), S(\mathbf{1}_i - \mathbf{1}_j) \rangle_{\ell^2(I)} > 0.$$

The notion of irreducibility of Definition 1.13 is very easy to check in the computations of Section 6, and quite convenient in the proof of Theorem 0.1. In the later theorem, we shall conclude that $S = R_0^{-1}$ for an irreducible bi-L-matrix R ; it is thus expected that this notion of irreducibility is related to the notion of irreducibility of bi-L-matrices of Sub-subsection 1.4.3.

Lemma 1.14.

Let R be an irreducible bi-L-matrix in the sense of Definition 1.8. Then R_0^{-1} is irreducible in the sense of Definition 1.13.

Proof. Our proof is probabilistic in nature, using potential theory for finite state Markov chains. Let I be the index set of the matrix R . Fix $\varepsilon > 0$ such that $P := \text{Id} - \varepsilon R$ is a stochastic matrix. Since R is irreducible, so is P . Since R is a bi-L-matrix, P preserves the counting measure on I .

Let $i \neq j \in I$. Let $P_{\{i,j\}}$ be the transition matrix for the induced Markov chain on $\{i, j\}$. Then, by [41, Corollary 1.1], and using the fact that all solutions of the Poisson equation on $\{i, j\}$ differ by a constant since P (and thus $P_{\{i,j\}}$) is irreducible,

$$\sum_{k \in \{i,j\}} (\mathbf{1}_i - \mathbf{1}_j)(k) \cdot (\text{Id} - P)^{-1}(\mathbf{1}_i - \mathbf{1}_j)(k) = \sum_{k \in \{i,j\}} (\mathbf{1}_i - \mathbf{1}_j)(k) \cdot (\text{Id} - P_{\{i,j\}})^{-1}(\mathbf{1}_i - \mathbf{1}_j)(k). \quad (1.10)$$

On the one hand, $(\text{Id} - P)^{-1} = \varepsilon^{-1} R_0^{-1}$. On the other hand, since $P_{\{i,j\}}$ is stochastic, irreducible and preserves the counting measure, there exist $t > 0$ such that

$$P_{\{i,j\}} = \begin{pmatrix} 1-t & t \\ t & 1-t \end{pmatrix}.$$

In particular, $P_{\{i,j\}} f = (1-2t)f$ for all $f \in \mathbb{C}_0^{\{i,j\}}$. Equation (1.10) becomes:

$$\langle (\mathbf{1}_i - \mathbf{1}_j), R_0^{-1}(\mathbf{1}_i - \mathbf{1}_j) \rangle_{\ell^2(I)} = \varepsilon \langle (\mathbf{1}_i - \mathbf{1}_j), (2t)^{-1}(\mathbf{1}_i - \mathbf{1}_j) \rangle_{\ell^2(I)} = \frac{\varepsilon}{t} > 0. \quad \square$$

1.5 Strategy and main results

Now that all the necessary objects have been introduced, let us present the strategy we follow and the main results that come along. We recall that, as sketched at the end of Sub-subsection 1.1.1, the strategy to compute the Markov kernel P_Σ on $[\Sigma]$ from a Markov kernel \tilde{P} on $[\mathbb{Z}^d]$ has three main steps:

- the balayage identity, which relates $(\text{Id} - \tilde{P})^{-1}$ and $(\text{Id} - P_\Sigma)^{-1}$;
- the ability to solve the Poisson equation on $[\mathbb{Z}^d]$, using the Fourier transform;
- the ability to invert $(\text{Id} - P_\Sigma)^{-1}$, or at least extract some information from it.

1.5.1 Koopman operator and Poisson equation

First, one must choose the right Markov kernel. A first choice is to use

$$\tilde{P}_x := \delta_{\tilde{T}(x)},$$

whose action on functions is the Koopman operator $\tilde{\mathcal{K}}$.

However, we then want to apply Theorem 1.1, which requires us to find solutions $g \in \mathbb{L}^\infty([\mathbb{Z}^d], \tilde{\mu})$ to the equation

$$f\mathbf{1}_{[\Sigma]} = (\text{Id} - \tilde{P})(g) = (\text{Id} - \tilde{\mathcal{K}})(g) = g - g \circ \tilde{T} \quad \tilde{\mu} - \text{almost everywhere}, \quad (1.11)$$

where $f\mathbf{1}_{[\Sigma]}$ is supported on $[\Sigma]$. The existence of solutions to this equation means that $f\mathbf{1}_{[\Sigma]}$ is a coboundary for \tilde{T} . Let us assume for now that the system (A, μ, T) is one of the simplest examples of Gibbs-Markov map: a subshift of finite type endowed with a Gibbs measure. Then the regularity

of g can be improved and the coboundary equation holds everywhere using a classical argument [21, Chapter 1.2].

On the other hand, we want to take $f \in \mathcal{B}_{[\Sigma],0}$, hence Lipschitz. By Theorem 1.1, we then have $\mu_{[\Sigma]}$ -almost everywhere

$$f = g_{[\Sigma]} - g_{[\Sigma]} \circ T_{[\Sigma]},$$

so that

$$\mathcal{L}_{[\Sigma]}(f) = (\mathcal{L}_{[\Sigma]} - \text{Id})(g_{[\Sigma]}).$$

Then, since $(\text{Id} - \mathcal{L}_{[\Sigma]})$ is invertible on $\mathcal{B}_{[\Sigma],0}$, the later equation admits a solution

$$g_0 := -(\text{Id} - \mathcal{L}_{[\Sigma]})^{-1} \mathcal{L}_{[\Sigma]}(f) \in \mathcal{B}_{[\Sigma]}.$$

As the kernel of the action of $(\text{Id} - \mathcal{L}_{[\Sigma]})$ on $\mathbb{L}^\infty([\Sigma], \mu_{[\Sigma]})$ is the space of constant functions by ergodicity, $g_{[\Sigma]} - g_0$ is constant almost everywhere, so that $g_{[\Sigma]}$ admits a Lipschitz version.

The same reasoning goes through with any finite $\Sigma \subset \Sigma'$ and yields that $g_{[\Sigma']}$ admits a Lipschitz version on $[\Sigma']$, whence g admits a locally Lipschitz version on $[\mathbb{Z}^d]$. In particular, taking for g this continuous version, the equality

$$f \mathbf{1}_{[\Sigma]} = g - g \circ \tilde{T}$$

holds everywhere, and not only $\tilde{\mu}$ -almost everywhere. As a consequence, for any point $(x, p) \in [\mathbb{Z}^d]$ of period $n \geq 1$,

$$\sum_{k=0}^{n-1} (f \mathbf{1}_{[\Sigma]}) \circ \tilde{T}^k(x, p) = 0. \quad (1.12)$$

This gives countably many obstructions to the existence of solutions to Equation (1.11). In addition, if the sites of Σ are far apart and $p \in \Sigma$, then there exist periodic orbits which intersect $[\Sigma]$ only in $[p]$. Then, if f is constant on $[p]$, the sum of Equation (1.12) is zero if and only if $f(\cdot, p) \equiv 0$. As this holds for all $p \in \Sigma$, we get $f \equiv 0$: the only function f which is constant on all sites and satisfy the coboundary equation is the null function.

A solution of this quandary is to use not the Koopman operator $\tilde{\mathcal{K}}$, but its dual $\tilde{\mathcal{L}}$.

1.5.2 Transfer operator and Poisson equation

The transformation \tilde{T} is assumed to be ergodic and recurrent, which implies that the Markov kernel $\tilde{\mathcal{K}}$ is also ergodic and recurrent. The operator $\tilde{\mathcal{L}}$ is dual to $\tilde{\mathcal{K}}$ with respect to $\tilde{\mu}$, and thus is also ergodic and recurrent by [41]. The relevant version of the balayage identity is [41, Proposition 0.1]:

Proposition 1.15 (Balayage identity for the transfer operator).

Let $(\tilde{A}, \tilde{\mu}, \tilde{T})$ be measure-preserving, with $\tilde{\mu}$ a recurrent σ -finite measure. Let $B \subset \tilde{A}$ be such that $0 < \tilde{\mu}(B) \leq +\infty$. Let $f, g \in \mathbb{L}^\infty(\tilde{A}, \tilde{\mu})$ be such that $f \equiv 0$ on B^c and:

$$(\text{Id} - \tilde{\mathcal{L}})(g) = f.$$

Then:

$$(\text{Id} - \mathcal{L}_B)(g_{|B}) = f_{|B}.$$

Note that, in Section 5, we shall actually use the more general [41, Lemma 1.7], which applies to equations such as $(\text{Id} - z\tilde{\mathcal{L}})(g) = f$ with $|z| < 1$. This generalization is only used to deal with convergence issues.

By the discussion at the end of Sub-subsection 1.3.2, for any $f \in \mathcal{B}_{[\Sigma],0}$, one can find a locally Lipschitz solution g to the equation $(\text{Id} - \tilde{\mathcal{L}})(g) = f$, which makes the balayage identity potentially useful. We still have two hurdles to cross:

- If we can construct (approximations of) solutions to the equation $(\text{Id} - \mathcal{L}_\Sigma)(g) = f_{[\Sigma]}$, how do we use them to extract data on \mathcal{L}_Σ , and in particular an approximation of the transition matrix P_Σ ?
- How do we construct (approximations of) solutions to the equation $(\text{Id} - \tilde{\mathcal{L}})(g\mathbf{1}_{[\Sigma]}) = f$?

Both of these problems will be addressed in an asymptotic regime, when the sites of Σ are far away one from the others. We delve deeper into these questions in the next two sub-subsections.

1.5.3 Towards the main theorem

Our solution to the first of these two problem is Theorem 0.1. Let us recall that it states that, for an ergodic and recurrent Markov \mathbb{Z}^d -extension of a Gibbs-Markov map and a family $\sigma_\varepsilon : I \hookrightarrow \mathbb{Z}^d$, there is equivalence between:

- there exists an irreducible (in the sense of Definition 1.8) bi-L-matrix R such that $P_\varepsilon = \text{Id} - \varepsilon R + o(\varepsilon)$;
- there exists an irreducible (in the sense of Definition 1.13) matrix S such that $Q_\varepsilon = \varepsilon^{-1}S + o(\varepsilon^{-1})$.

If in addition any of these properties holds, then $S = R_0^{-1}$.

Remark 1.16 (Theorem 0.1 and averaging operator).

Using the operators Π_ and Π^* as well as transfer operators, Theorem 0.1 states that, under an irreducibility condition, the finite-dimensional operators $(\text{Id} - \Pi_*\mathcal{L}_\varepsilon\Pi^*)^{-1}$ and $\Pi_*(\text{Id} - \mathcal{L}_\varepsilon)^{-1}\Pi^*$ are equivalent.*

Remark 1.17 (Intrinsic version of Theorem 0.1).

The statement of Theorem 0.1 depends both on the parametrization of the subsets Σ_ε and the precise speed of convergence of P_ε to Id . While easy to state and convenient for computations, a more intrinsic version can be crafted. First, notice that the irreducibility conditions 1.10 and 1.12 are satisfied on open cones in the relevant subspaces of $M_n(\mathbb{R})$, or in other words, on projectively open sets. We can then restate Theorem 0.1 as follows.

Consider an ergodic and recurrent Markov \mathbb{Z}^d -extension of a Gibbs-Markov map and a family of finite subsets $(\Sigma_\varepsilon)_{\varepsilon>0}$ all of the same size and such that

$$\lim_{\varepsilon \rightarrow 0} \min_{p \neq q \in \Sigma_\varepsilon} |p - q| = +\infty.$$

Then there is equivalence between:

- $(\text{Id} - P_\varepsilon)_{\varepsilon>0}$ is projectively relatively compact for Hypothesis 1.10.

- $(Q_\varepsilon)_{\varepsilon>0}$ is projectively relatively compact for Hypothesis 1.12.

If either condition is satisfied, then $(I - P_\varepsilon)|_{\mathbb{C}_0^I}^{-1} \sim_{\varepsilon \rightarrow 0} Q_\varepsilon$.

The matrix Q_ε can be computed when one evaluates the quantities

$$\langle \Pi_*(\text{Id} - \mathcal{L}_\varepsilon)^{-1} \Pi^*(f), g \rangle_{\ell^2(I)},$$

for $f, g \in \mathbb{C}_0^I$. Theorem 0.1 gives the desired asymptotics for R . The initial infinite-dimensional problem of inverting $(\text{Id} - \mathcal{L}_\varepsilon)^{-1}$ is reduced to the finite-dimensional problem of inverting Q_ε .

The proof of Theorem 0.1 spans three sections. First, it will be very convenient to assume that the induced system $(A, \mu, T_{[0]})$ is mixing. This shall be denoted as a separate hypothesis:

Hypothesis 1.18 (Mixing).

The system $(A, \mu, T_{[0]})$ is mixing.

Section 2 is devoted to the proof of the direct implication in Theorem 0.1 under Hypothesis 1.18:

Lemma 1.19.

Let $([\mathbb{Z}^d], \tilde{\mu}, \tilde{T})$ be an ergodic and recurrent Markov \mathbb{Z}^d -extension of a Gibbs-Markov map (Hypothesis 1.2). Let I be finite and, and let $\sigma_\varepsilon : I \hookrightarrow \mathbb{Z}^d$ for all $\varepsilon > 0$.

Assume furthermore that $([0], \mu_{[0]}, T_{[0]})$ is mixing (Hypothesis 1.18).

If there exists an irreducible bi-L-matrix R such that $P_\varepsilon = \text{Id} - \varepsilon R + o(\varepsilon)$ (Hypothesis 1.10), then $Q_\varepsilon = \varepsilon^{-1} R_0^{-1} + o(\varepsilon^{-1})$. In addition, R_0^{-1} is irreducible in the sense of Definition 1.13.

Lemma 1.19 is the heart of the proof of Theorem 0.1. Its proof is inspired by works on the hitting time of small target for hyperbolic systems [42, 26] and invariant cones for fast-slow systems [12]; we refer the reader to the introduction of Section 2 for more details.

Once this is done, in Section 3 we shall remove this mixing assumption. If $([0], \mu_{[0]}, T_{[0]})$ is not mixing, then it has a decomposition into periodic components. This step requires us to understand what effects the existence of such periodic components have on the whole extension $([\mathbb{Z}^d], \tilde{\mu}, \tilde{T})$; to our knowledge, these structural results (in particular Propositions 3.2 and 3.3) are new and of independent interest.

This analysis is independent from Section 2. That said, we think it is clearer to give the proof of Lemma 1.19 with the additional mixing assumption, and then point out the differences non-mixing implies, than to write directly the proof of Lemma 1.19 in a non-mixing context. At the end of Section 3, we shall have proved:

Lemma 1.20.

Let $([\mathbb{Z}^d], \tilde{\mu}, \tilde{T})$ be an ergodic and recurrent Markov \mathbb{Z}^d -extension of a Gibbs-Markov map (Hypothesis 1.2). Let I be finite and, and choose $\sigma_\varepsilon : I \hookrightarrow \mathbb{Z}^d$ for all $\varepsilon > 0$.

If there exists an irreducible bi-L-matrix R such that $P_\varepsilon = \text{Id} - \varepsilon R + o(\varepsilon)$ (Hypothesis 1.10), then $Q_\varepsilon = \varepsilon^{-1} R_0^{-1} + o(\varepsilon^{-1})$. In addition, R_0^{-1} is irreducible in the sense of Definition 1.13.

The final step is to reverse the implication, so as to get Theorem 0.1. This is the goal of Section 4. This uses the $|I| = 2$ case of the theorem (which is deduced directly from Lemma 1.20) and a compactness argument.

1.5.4 Applications

We are given an ergodic and recurrent Markov \mathbb{Z}^d -extension of a Gibbs-Markov map and a family $(\sigma_\varepsilon)_{\varepsilon>0}$ of injection from I into \mathbb{Z}^d . All is left is, given $f, g \in \mathbb{C}_0^\Sigma$, to estimate the integrals

$$\langle f, Q_\varepsilon(g) \rangle_{\ell^2(I)} = |I| \langle (\text{Id} - \mathcal{L}_\varepsilon)^{-1} \Pi^*(f), \Pi^*(g) \rangle_{\mathbb{L}^2(I, \mu_I)}$$

when ε vanishes. Thanks to the balayage identity, this reduces formally to the computation of the quantities (identifying I with Σ_ε)

$$\langle \Pi_*(\text{Id} - \tilde{\mathcal{L}})^{-1} (\Pi^*(f) \mathbf{1}_{[\Sigma_\varepsilon]}), \Pi^*(g) \mathbf{1}_{[\Sigma_\varepsilon]} \rangle_{\mathbb{L}^2([\mathbb{Z}^d], \tilde{\mu})}.$$

As with random walks, this can be done using the Fourier transform. The main difference is that this operation makes so-called *twisted transfer operators* appear.

Definition 1.21 (Twisted transfer operators).

For $w \in \mathbb{T}^d := \mathbb{R}^d / 2\pi\mathbb{Z}^d$, define the twisted transfer operator:

$$\mathcal{L}_w(\cdot) := \mathcal{L}(e^{i\langle w, F \rangle} \cdot), \quad (1.13)$$

which acts on $\mathbb{L}^p(A, \mu)$ for all $p \in [1, \infty]$, as well as on \mathcal{B} .

Our applications are done in two steps. In Section 5, we shall use these twisted transfer operators to give a general expression for the quantities $\langle f, Q_\varepsilon(g) \rangle_{\ell^2(I)}$. Proposition 5.3 states that, in our setting, for all $\varepsilon > 0$,

$$\langle f, Q_\varepsilon(g) \rangle_{\ell^2(I)} = \lim_{\rho \rightarrow 1^-} \frac{1}{(2\pi)^d} \int_{\mathbb{T}^d} \check{\mathcal{F}}_{\sigma_\varepsilon}(f) \mathcal{F}_{\sigma_\varepsilon}(g) \left(\int_A (\text{Id} - \rho \mathcal{L}_w)^{-1}(\mathbf{1}) \, d\mu \right) \, dw,$$

where $\mathcal{F}_{\sigma_\varepsilon}(g)$ is the Fourier transform of $(g \circ \sigma_\varepsilon^{-1}) \mathbf{1}_{\Sigma_\varepsilon}$.

In the same spirit as the Nagaev-Guivarc'h proof of the central limit theorem for dynamical systems [36, 37, 22], when the sites are far apart, the main contribution to these integrals will be given by the main eigenvalue λ_w of \mathcal{L}_w , for w close to 0. We shall prove that, for any small enough neighborhood U of 0,

$$\langle f, Q_\varepsilon(g) \rangle_{\ell^2(I)} = \lim_{\rho \rightarrow 1^-} \frac{1}{(2\pi)^d} \int_U \check{\mathcal{F}}_{\sigma_\varepsilon}(f) \mathcal{F}_{\sigma_\varepsilon}(g) \frac{1 + \delta_w}{1 - \rho \lambda_w} \, dw + O_U(1) \|f\| \cdot \|g\|,$$

with δ_w a small error term.

In Section 6, we apply the latter equation to different classes of jump function F when $\sigma_t(i) = t\sigma(i) + o(1)$ for all $i \in I$. For $d = 2$ and $\|F\| \in \mathbb{L}^2(A, \mu)$, this yields Proposition 0.2. For $d = 1$ and F in the basin of attraction of a Cauchy random variable⁴, we get a similar asymptotics, stated in Proposition 6.8. We are also able to give asymptotics for P_ε when $d = 1$ and F is square-integrable, in Proposition 6.1. Finally, we give some partial results when $d = 1$ and F is in the basin of attraction of a Lévy random variable (i.e. when F has regularly varying tails of index in $(0, 1)$). We are able to give an explicit expression for S , stated in Proposition 6.4, but we could not find an explicit expression for its inverse. We are still able to compute the asymptotics for a fixed extension and fixed $(\sigma_t)_{t>0}$, as done in Examples 6.5 and 6.6.

⁴In addition to some technical constraints

2 From transition probabilities to potential

The goal of this section is to prove Lemma 1.19: if $([0], \mu_{[0]}, T_{[0]})$ is mixing and $P_\varepsilon = \text{Id} - \varepsilon R + o(\varepsilon)$ for some irreducible bi-L-matrix R , then $Q_\varepsilon = \varepsilon^{-1} R_0^{-1} + o(\varepsilon^{-1})$.

The transition matrix P_ε can be computed from the transfer operator \mathcal{L}_ε using the relation ${}^t P_\varepsilon = \Pi_* \mathcal{L}_\varepsilon \Pi^*$ (Equation (1.8)). From another point of view, $\Pi^{*t} P_\varepsilon \Pi_* = (\Pi^* \Pi_*) \mathcal{L}_\varepsilon$ could be seen as a finite-rank approximation of \mathcal{L}_ε . Such an approximation is reminiscent of works on metastable states by Keller and Liverani [29] (for two communicating systems), as well as by Dolgopyat and Wright [17] (for interval maps).

At first sight, this approximation is not very good: in general, $\|(\text{Id} - \Pi^* \Pi_*) \mathcal{L}_\varepsilon\|_{\mathcal{B} \rightarrow \mathcal{B}}$ is of order 1, because of the non-trivial behaviour of \mathcal{L}_ε on each site $[i]$. A solution would be to focus on functions which are constant on each site; however, this subspace is not stable under \mathcal{L}_ε .

On each site, the effect of \mathcal{L}_ε is roughly that of $\mathcal{L}_{[0]}$, which mixes exponentially quickly. The transitions between sites introduce an error of order ε . The interaction of these two dynamical effects imply the existence of cones of functions $C_K(\varepsilon)$ (functions which are ε -close to being constant on each site) which are invariant under \mathcal{L}_ε . By restricting ourselves to such cones, we shall be able to improve the bounds on $(\text{Id} - \Pi^* \Pi_*) \mathcal{L}_\varepsilon$. The goal of Subsection 2.1 is thus to prove that such cones are stable under the action of \mathcal{L}_ε , and moreover to prove a cone contraction property which shall be instrumental in the next steps.

Remark 2.1 (Fast-slow systems).

Such families of cones of functions have some precedent in ergodic theory. One feature of the sequence of operators \mathcal{L}_ε is that the evolution of $(\mathcal{L}_\varepsilon)_{n \geq 0}$ has two characteristic time scales. At a time scale of $\Theta(1)$, the mixing property of $([0], \mu_{[0]}, T_{[0]})$ homogenizes each site $[i]$, but there is little communication between distinct sites. The transitions between sites occur at a time scale of $\Theta(\varepsilon^{-1})$. When ε vanishes, these two time scales become decoupled, so that the transitions become independent.

The existence of two distinct time scales is also a feature of fast-slow systems. For instance, consider a family of maps F_ε acting on $\Omega \times \mathbb{S}_1$ such that

$$F_\varepsilon(x, \theta) = (f_\varepsilon(x, \theta), \theta + \varepsilon g(x, \theta))$$

and $x \mapsto f_\varepsilon(x, \theta)$ is a family of uniformly hyperbolic transformations on Ω . Then the first variable, x , evolves on a time scale of $\Theta(1)$, and the second variable, θ , on a time scale of $\Theta(\varepsilon^{-1})$. When ε vanishes, these two time scales become decoupled, so that the evolution of θ is averaged over the values of x .

In the context of fast-slow systems, such parametric families of cones – or, similarly, standard families – have been introduced. We refer the interested reader to [12] for an exposition of these techniques, and [15, 9, 13] for applications to partially hyperbolic systems and Sinai billiard maps. In particular, we stress the similarity between [12, Proposition 3.1] and Corollary 2.6.

Once we have proved the stability of these cones, the error term between \mathcal{L}_ε and $(\Pi^* \Pi_*) \mathcal{L}_\varepsilon$ will be improved. In Subsection 2.2, together with a version of the Baker-Campbell-Hausdorff formula, this shall let us control the error between their products on a time scale of $\Theta(\varepsilon^{-1})$. In particular, if f is constant on each site, then, for all positive t , the operator $\mathcal{L}_\varepsilon^{\lfloor \varepsilon^{-1} t \rfloor}(f)$ converges to $\Pi^* e^{-tR} \Pi_* f$. This exponential decay is typical of previous work on the hitting time of small targets [42, 26]. Let us also point out [30, 6] for settings where rare events correspond to strong changes in the system, and where the behaviour of the system after those changes has to be controlled.

Finally, in Subsection 2.3, the exponential contraction at time scale $\Theta(1)$ together with a coupling argument gets us exponential bounds on the decay of correlations which are uniform in $\varepsilon^{-1}t$. Note that this coupling argument is classical for Markov chains [35, Chapter 5] and has a long tradition in ergodic theory (present for instance in most applications of standard pairs; see e.g. [10] for applications to Sinai billiards maps). Once this is done, we are able to relate $(\text{Id} - \mathcal{L}_\varepsilon)^{-1}$ with the inverse of R^{-1} through a Laplace transform, finishing the proof of Lemma 1.19.

2.1 Cone contraction at time scale $\Theta(1)$

Let $([\mathbb{Z}^d], \tilde{\mu}, \tilde{T})$ be an ergodic and recurrent Markov \mathbb{Z}^d -extension of a Gibbs-Markov map (Hypothesis 1.2). Let I be finite and, and choose $\sigma_\varepsilon : I \hookrightarrow \mathbb{Z}^d$ for all $\varepsilon > 0$.

As announced earlier, we introduce cones of functions which are ε -close to being constant on each site, and prove that they are stable under some iterate of \mathcal{L}_ε , as well as a cone contraction property.

Definition 2.2 (Cones of functions).

For all $K \geq 0$ and $\varepsilon > 0$, let:

$$C_K(\varepsilon) := \left\{ f : [I] \rightarrow \mathbb{R} : f \geq 0 \text{ and } \|(\text{Id} - \Pi^* \Pi_*)f\|_{\mathcal{B}_I} \leq K\varepsilon \|f\|_{\mathbb{L}^1([I], \mu_I)} \right\}.$$

These subsets of \mathcal{B}_I are indeed convex cones, as we can quickly check:

Lemma 2.3.

For all $K, \varepsilon \geq 0$, the set $C_K(\varepsilon)$ is a convex cone.

Proof. Let $K, \varepsilon \geq 0$. Given $f \in C_K(\varepsilon)$ and $\lambda \geq 0$,

$$\|(\text{Id} - \Pi^* \Pi_*)(\lambda f)\|_{\mathcal{B}_I} = \lambda \|(\text{Id} - \Pi^* \Pi_*)f\|_{\mathcal{B}_I} \leq \lambda K\varepsilon \|f\|_{\mathbb{L}^1([I], \mu_I)} = K\varepsilon \|\lambda f\|_{\mathbb{L}^1([I], \mu_I)},$$

so that $\lambda f \in C_K(\varepsilon)$. In addition, for all $f, g \in C_K(\varepsilon)$ and $t \in [0, 1]$:

$$\begin{aligned} \|(\text{Id} - \Pi^* \Pi_*)((1-t)f + tg)\|_{\mathcal{B}_I} &\leq (1-t) \|(\text{Id} - \Pi^* \Pi_*)f\|_{\mathcal{B}_I} + t \|(\text{Id} - \Pi^* \Pi_*)g\|_{\mathcal{B}_I} \\ &\leq K\varepsilon \left((1-t) \|f\|_{\mathbb{L}^1([I], \mu_I)} + t \|g\|_{\mathbb{L}^1([I], \mu_I)} \right) \\ &= K\varepsilon \|(1-t)f + tg\|_{\mathbb{L}^1([I], \mu_I)}, \end{aligned}$$

where we used the fact that $\|\cdot\|_{\mathbb{L}^1([I], \mu_I)}$ is linear on nonnegative functions. Hence $(1-t)f + tg$ also belongs to $C_K(\varepsilon)$. \square

Another fundamental property of these cones is that, since any function in $C_K(\varepsilon)$ is close for the \mathcal{B}_I norm to the finite dimensional space of functions constant on each $[i]$, many norms are equivalent on $C_K(\varepsilon)$. In particular, we can control the \mathcal{B}_I norm (the strongest norm we shall use) with the $\mathbb{L}^1([I], \mu_I)$ norm (the weakest norm we shall use).

Lemma 2.4.

Let $K, \varepsilon \geq 0$. For all $f \in C_K(\varepsilon)$,

$$\|f\|_{\mathcal{B}_I} \leq (|I| + K\varepsilon) \|f\|_{\mathbb{L}^1([I], \mu_I)}. \quad (2.1)$$

Proof. Let $K, \varepsilon \geq 0$. For all $f \in C_K(\varepsilon)$,

$$\begin{aligned} \|f\|_{B_I} &\leq \|(\text{Id} - \Pi^* \Pi_*)f\|_{B_I} + \|\Pi^* \Pi_* f\|_{B_I} \\ &\leq K\varepsilon \|f\|_{\mathbb{L}^1([I], \mu_I)} + |I| \|\Pi^* \Pi_* f\|_{\mathbb{L}^1([I], \mu_I)} \\ &= (|I| + K\varepsilon) \|f\|_{\mathbb{L}^1([I], \mu_I)}, \end{aligned}$$

where we used the fact that $\|\cdot\|_{B_I} = \|\cdot\|_\infty \leq |I| \|\cdot\|_{\mathbb{L}^1([I], \mu_I)}$ on functions which are constant on each $[i]$. \square

Given these preliminary results, we shall now prove that, under the assumptions of Lemma 1.19, the cones $C_K(\varepsilon)$ are contracted under some iterate of \mathcal{L}_ε whenever K is large enough. Taking $\sigma = 1$ in the following proposition also yield their stability.

Proposition 2.5.

Assume Hypotheses 1.2, 1.18 and 1.10.

For all $\sigma > 0$, there exist $K_\sigma, n_\sigma \geq 0$ such that, for all $K \geq K_\sigma$, for all $\varepsilon > 0$ and $n \geq n_\sigma$,

$$\mathcal{L}_\varepsilon^n(C_K(\varepsilon)) \subset C_{\sigma K}(\varepsilon).$$

Proof. Let $K \geq 0$ and ε, n be positive. Define:

$$B_n := \{(x, i) \in [I] : T_\varepsilon^k(x, i) \in [i] \forall 0 \leq k \leq n\} = \bigsqcup_{i \in I} \bigcap_{k=0}^n T_\varepsilon^{-k}([i]),$$

the set of points which stay in the same site until time n . By Hypothesis 1.10, there exists a constant C such that, for all $i \in I$ and all $\varepsilon > 0$,

$$\mu(x \in A : T_\varepsilon(x, i) \notin [i]) = \sum_{j \neq i} (\delta_{ij} - \varepsilon R_{ij} + o(\varepsilon)) = -\varepsilon \sum_{j \neq i} R_{ij} + o(\varepsilon) \leq C\varepsilon.$$

Hence,

$$\begin{aligned} \mu_I \left(\left(\bigcap_{k=0}^n T_\varepsilon^{-k}([i]) \right)^c \right) &= \sum_{k=1}^n \mu_I(x : T_\varepsilon^0(x, i), \dots, T_\varepsilon^{k-1}(x, i) \in [i], T_\varepsilon^k(x, i) \notin [i]) \\ &\leq \sum_{k=1}^n \mu_I(x : T_\varepsilon^{k-1}(x, i) \in [i], T_\varepsilon^k(x, i) \notin [i]) \\ &= n \mu_I(x : T_\varepsilon(x, i) \notin [i]) \\ &\leq C|I|^{-1} n \varepsilon. \end{aligned}$$

Summing over $i \in I$ yields $\mu_I(B_n^c) \leq Cn\varepsilon$.

Let $i \in I$ and $f \in C_K(\varepsilon)$. As the transfer operator preserves nonnegative functions, $\mathcal{L}_\varepsilon^n(f) \geq 0$. Let us focus on the regularity of $\mathcal{L}_\varepsilon^n(f)$.

First, by definition of B_n , given any point $(x, i) \in B_n$, the trajectories of the points $(x, \sigma_\varepsilon(i))$, $T_{[\Sigma_\varepsilon]}(x, \sigma_\varepsilon(i))$, \dots , $T_{[\Sigma_\varepsilon]}^{n-1}(x, \sigma_\varepsilon(i))$ under \tilde{T} all return to $[\sigma_\varepsilon(i)]$ before hitting any $[\sigma_\varepsilon(j)]$ with $j \neq i$. Hence, by recursion, for all $0 \leq k \leq n$ and all $x \in B_n$,

$$T_{[\Sigma_\varepsilon]}^k(x, \sigma_\varepsilon(i)) = (T_{[0]}^k(x), \sigma_\varepsilon(i)),$$

so that:

$$\mathcal{L}_\varepsilon^n(f\mathbf{1}_{B_n})(\cdot, i) = \mathcal{L}_{[0]}^n((f\mathbf{1}_{B_n})(\cdot, i)). \quad (2.2)$$

From Equation (2.2) we get:

$$\begin{aligned} \mathcal{L}_\varepsilon^n(f)(\cdot, i) &= \mathcal{L}_\varepsilon^n(f\mathbf{1}_{B_n})(\cdot, i) + \mathcal{L}_\varepsilon^n(f\mathbf{1}_{B_n^c})(\cdot, i) \\ &= \mathcal{L}_{[0]}^n((f\mathbf{1}_{B_n})(\cdot, i)) + \mathcal{L}_\varepsilon^n(f\mathbf{1}_{B_n^c})(\cdot, i) \\ &= \mathcal{L}_{[0]}^n(f(\cdot, i)) - \mathcal{L}_{[0]}^n((f\mathbf{1}_{B_n^c})(\cdot, i)) + \mathcal{L}_\varepsilon^n(f\mathbf{1}_{B_n^c})(\cdot, i). \end{aligned}$$

We shall now use Corollaries A.7 and A.9 to control each term. Stopping times are defined in terms of the canonical filtration on (A, μ, T) , while $\mathcal{L}_{[0]}$ and \mathcal{L}_ε are defined *via* the extension $([\mathbb{Z}^d], \tilde{\mu}, \tilde{T})$. We thus need to express some characteristics of the trajectories $(T_\varepsilon^n(x, i))_{n \geq 0}$ in terms of cylinders for (A, μ, T) , as is done in the proof of Proposition A.8.

Let $\varphi_{[0]}(x) := \inf\{n \geq 1 : \sum_{k=0}^{n-1} S_k F(x) = 0\}$. Then $\varphi_{[0]}$ is a stopping time in the sense of Definition A.2. Since $([\mathbb{Z}^d], \tilde{\mu}, \tilde{T})$ is measure-preserving and recurrent, the map $T_{\varphi_{[0]}} = T_{[0]}$ preserves μ and is ergodic. Finally, by Hypothesis 1.18, the map $T_{[0]}$ is also mixing for μ . Hence we can apply Corollary A.9, which asserts that there exist constants $C > 0$ and $\rho \in (0, 1)$ such that, for all $i \in I$,

$$\left\| \mathcal{L}_{[0]}^n(f(\cdot, i)) - \int_A f(\cdot, i) d\mu \right\|_{\mathcal{B}} \leq C\rho^n \left\| f(\cdot, i) - \int_A f(\cdot, i) d\mu \right\|_{\mathcal{B}} \leq C\rho^n \|(\text{Id} - \Pi^* \Pi_*)f\|_{\mathcal{B}_I}. \quad (2.3)$$

Let $i \in I$. The set $B_n^c \cap [I]$ is measurable with respect to the σ -algebra $\alpha(\varphi_{[0]}^{(n)})$, since, using the identification $[i] \simeq A$,

$$B_n \cap [I] = \bigcup_{k=0}^{n-1} T_{[0]}^{-k}(\{\exists 0 \leq \ell < \varphi_{[0]}(x), \exists j \in I \setminus \{i\}, S_\ell F(x) = \sigma_\varepsilon(j) - \sigma_\varepsilon(i)\}).$$

As $\varphi_{[0]}^{(n)}$ is a stopping time by Lemma A.3, we can apply Corollary A.7 to get, for some constant C and all $i \in I$,

$$\left\| \mathcal{L}_{[0]}^n((f\mathbf{1}_{B_n^c})(\cdot, i)) \right\|_{\mathcal{B}} \leq C\mu(B_n^c \cap [i]) \|f(\cdot, i)\|_{\mathcal{B}}. \quad (2.4)$$

In the same way, fix $i, j \in I$ and let $\varphi_{j,n,\varepsilon}(x) := \inf\{\ell \geq 1 : \text{Card}\{S_\ell F(x) \in \{j' - j : j' \in I\}\} = n\}$. The set $B_n^c \cap [j]$ is measurable with respect to the σ -algebra $\alpha(\varphi_{j,n,\varepsilon})$. By Corollary A.7, for some constant C ,

$$\begin{aligned} \left\| \mathcal{L}_\varepsilon^n(f\mathbf{1}_{B_n^c \cap [j]})(\cdot, i) \right\|_{\mathcal{B}} &= \left\| \mathcal{L}_{\varphi_{j,n,\varepsilon}}(f\mathbf{1}_{B_n^c \cap [j] \cap \{S_{\varphi_{j,n,\varepsilon}} F = i - j\}}) \right\|_{\mathcal{B}} \\ &\leq C\mu(B_n^c \cap [j]) \|f(\cdot, j)\|_{\mathcal{B}} \\ &= C|I|\mu_I(B_n^c \cap [j]) \|f(\cdot, j)\|_{\mathcal{B}}. \end{aligned}$$

Summing over $j \in I$ finally yields

$$\left\| \mathcal{L}_\varepsilon^n(f\mathbf{1}_{B_n^c})(\cdot, i) \right\|_{\mathcal{B}} \leq C|I|\mu_I(B_n^c) \|f\|_{\mathcal{B}_I}. \quad (2.5)$$

Equations (2.1), (2.3), (2.4) and (2.5) together yield, for some positive constant C and all $n \geq 1$:

$$\begin{aligned} \left\| \mathcal{L}_\varepsilon^n(f)(\cdot, i) - \int_A f(\cdot, i) d\mu \right\|_{\mathcal{B}} &\leq C\rho^n \|(\text{Id} - \Pi^* \Pi_*)f\|_{\mathcal{B}_I} + C\mu_I(B_n^c) \|f\|_{\mathcal{B}_I} \\ &\leq C(K\rho^n + n)\varepsilon \|f\|_{\mathbb{L}^1([I], \mu_I)}. \end{aligned} \quad (2.6)$$

As T_ε preserves μ_I and f is nonnegative, $\|\mathcal{L}_\varepsilon^n(f)\|_{\mathbb{L}^1([I],\mu_I)} = \|f\|_{\mathbb{L}^1([I],\mu_I)}$. By Equation (2.6),

$$\mathcal{L}_\varepsilon^n(C_K(\varepsilon)) \subset C_{C(K\rho^n+n)}(\varepsilon). \quad (2.7)$$

Now, we finish the proof of Proposition 2.5. Let $\sigma > 0$. Without loss of generality, we assume that $\sigma \leq 1$. Let $n_\sigma \geq 1$ be such that $C\rho^{n_\sigma} \leq \sigma/2$. Let $K_\sigma := 4C\sigma^{-1}n_\sigma$. Then, for all $K \geq K_\sigma$ and $\varepsilon > 0$, for all $n_\sigma \leq n \leq 2n_\sigma$, by Equation (2.7),

$$C(K\rho^n + n) \leq C(K\rho^{n_\sigma} + 2n_\sigma) \leq \frac{\sigma K}{2} + \frac{\sigma K_\sigma}{2} \leq \sigma K,$$

so that $\mathcal{L}_\varepsilon^n(C_K(\varepsilon)) \subset C_{\sigma K}(\varepsilon)$.

By recursion, let us prove that $\mathcal{L}_\varepsilon^{mn_\sigma}(C_K(\varepsilon)) \subset C_K(\varepsilon)$ for all $m \geq 0$. This is true for $m = 0$, and if it holds for some $m \geq 0$, then

$$\mathcal{L}_\varepsilon^{(m+1)n_\sigma}(C_K(\varepsilon)) = \mathcal{L}_\varepsilon^{n_\sigma} \mathcal{L}_\varepsilon^{mn_\sigma}(C_K(\varepsilon)) \subset \mathcal{L}_\varepsilon^{n_\sigma}(C_K(\varepsilon)) \subset C_{\sigma K}(\varepsilon) \subset C_K(\varepsilon),$$

which finishes this recursion.

Finally, for all $n \geq n_\sigma$, since $n_\sigma \leq n - n_\sigma \lfloor n/n_\sigma \rfloor + n_\sigma \leq 2n_\sigma$,

$$\mathcal{L}_\varepsilon^n(C_K(\varepsilon)) = \mathcal{L}_\varepsilon^{n-n_\sigma \lfloor n/n_\sigma \rfloor + n_\sigma} \mathcal{L}_\varepsilon^{n_\sigma \lfloor n/n_\sigma \rfloor}(C_K(\varepsilon)) \subset \mathcal{L}_\varepsilon^{n-n_\sigma \lfloor n/n_\sigma \rfloor + n_\sigma}(C_K(\varepsilon)) \subset C_{\sigma K}(\varepsilon). \quad \square$$

As a consequence, if K is large enough and up to the loss of a constant factor, $C_K(\varepsilon)$ is stable under $\mathcal{L}_\varepsilon^n$ for all $n \geq 0$. This corollary shall give us a good control on $\|\mathcal{L}_\varepsilon^n f\|_{\mathcal{B}_I}$ provided we know that $f \in C_K(\varepsilon)$.

Corollary 2.6.

Assume Hypotheses 1.2, 1.18 and 1.10.

There exists K_1 and $\lambda_1 \geq 1$ such that, for all $K \geq K_1$, for all $n \geq 0$ and $\varepsilon > 0$,

$$\mathcal{L}_\varepsilon^n(C_K(\varepsilon)) \subset C_{\lambda_1 K}(\varepsilon).$$

Proof. Let n_1, K_1 be given by Proposition 2.5. By Proposition 2.5, for all $K \geq K_1$, for all $n \geq n_1$ and all $\varepsilon > 0$,

$$\mathcal{L}_\varepsilon^n(C_K(\varepsilon)) \subset C_K(\varepsilon).$$

In addition, by Equation (2.7), for all $n \leq n_1$ and $\varepsilon > 0$,

$$\mathcal{L}_\varepsilon^n(C_K(\varepsilon)) \subset C_{C(K+n_1)}(\varepsilon).$$

We choose $\lambda_1 := C(1 + n_1/K_1)$. □

2.2 Product of matrices

Given $f \in C_K(\varepsilon)$, Corollary 2.6 asserts that $\mathcal{L}_\varepsilon^n f$ is close to being constant on each site for all $n \geq 0$; the operator \mathcal{L}_ε is then well approximated by the finite rank operator $\Pi^{*t} P_\varepsilon \Pi_*$. However, to understand what happens at time scale ε^{-1} , we need to control a composition of a large number (of order ε^{-1}) of such operators. To keep reasonably sharp error bounds, we use a version of the Baker-Campbell-Hausdorff formula.

Lemma 2.7.

Let $N \geq 1$. There exists a neighbourhood U of 0 in $M_N(\mathbb{C})$ and a constant $C > 0$ such that, for all matrices A and B in U ,

$$\|\ln(e^A e^B) - A - B\| \leq C \|[A, B]\|. \quad (2.8)$$

The ability to bound $\ln(e^A e^B) - A - B$ using only commutators is natural if one thinks about the Baker-Campbell-Hausdorff formula:

$$e^A e^B = e^{A+B+\frac{1}{2}[A,B]+\frac{1}{12}[A,[A,B]]+\frac{1}{12}[B,[B,A]]+\dots}.$$

We prove it using an integral version of this formula.

Proof. Whenever A and B are small enough, $\ln(e^A e^B)$ can be written with an integral Baker-Campbell-Hausdorff formula [23, Theorem 3.3]:

$$\ln(e^A e^B) = A + \int_0^1 u(e^{\text{ad}_A} e^{t \text{ad}_B}) dt (B),$$

where $u(z) = \frac{z \ln(z)}{z-1}$. Set:

$$v(z) := \frac{z \ln(z) - z + 1}{(z-1)^2} = \frac{u(z) - 1}{z-1}, \quad w(z) := \frac{e^z - 1}{z}.$$

The functions v and w are analytic on a neighbourhood of the identity, and for all small enough A and B :

$$\begin{aligned} \ln(e^A e^B) - A - B &= \int_0^1 u(e^{\text{ad}_A} e^{t \text{ad}_B}) dt (B) - B \\ &= \int_0^1 (u - 1)(e^{\text{ad}_A} e^{t \text{ad}_B}) dt (B) \\ &= \int_0^1 v(e^{\text{ad}_A} e^{t \text{ad}_B}) (e^{\text{ad}_A} e^{t \text{ad}_B} - 1) (B) dt \\ &= \int_0^1 v(e^{\text{ad}_A} e^{t \text{ad}_B}) (e^{\text{ad}_A} - 1) (B) dt \\ &= \int_0^1 v(e^{\text{ad}_A} e^{t \text{ad}_B}) dt w(\text{ad}_A) ([A, B]). \end{aligned}$$

Since both $v(e^{\text{ad}_A} e^{t \text{ad}_B})$ and $w(\text{ad}_A)$ are uniformly bounded for A and B on a neighbourhood of the identity, we get the claim. \square

Using Lemma 2.7 recursively, we can control the product of a large number (of order $\Theta(\varepsilon^{-1})$) of matrices which are $o(\varepsilon)$ -close from a reference matrix R .

Lemma 2.8.

Let $N \geq 1$ and $R \in M_N(\mathbb{C})$. Let ω be a nonnegative function such that $\omega(\varepsilon) =_{\varepsilon \rightarrow 0} o(\varepsilon)$. Let $(R_{\varepsilon,n})_{\varepsilon > 0, n \geq 0}$ be a family of matrices in $M_N(\mathbb{C})$ such that

$$\sup_{n \geq 0} \|R_{\varepsilon,n}\| \leq \omega(\varepsilon).$$

For all $\varepsilon > 0$ and $t \geq 0$, let:

$$M_\varepsilon(t) := \prod_{n=0}^{\lfloor \varepsilon^{-1}t \rfloor - 1} (\text{Id} - \varepsilon R + R_{\varepsilon,n}),$$

where the matrices are multiplied in any order. Then the family of matrix-valued functions $(M_\varepsilon)_{\varepsilon>0}$ converges to $t \mapsto e^{-tR}$ when ε vanishes, uniformly on all compacts of \mathbb{R}_+ , and for fixed ω uniformly in $(R_{\varepsilon,n})_{\varepsilon>0, n \geq 0}$.

Proof. Let R and $(R_{\varepsilon,n})_{\varepsilon>0, n \geq 0}$ be as in the hypotheses of the lemma. Define:

$$R'_{\varepsilon,n} := \ln(\text{Id} - \varepsilon R + R_{\varepsilon,n}) + \varepsilon R.$$

Note that $\omega'(\varepsilon) := \sup_{n \geq 0} \|R'_{\varepsilon,n}\| = O(\omega(\varepsilon))$.

Let U be a neighbourhood of 0 in $M_N(\mathbb{C})$ and $C > 0$ as given by Lemma 2.7. We put $K := 2C \max\{\|R\|, 1\}$. Let t_0 be small enough that U contains $\{-tR : 0 \leq t \leq t_0\}$.

We claim that, for all small enough ε , for all $n \leq \lfloor \varepsilon^{-1}t_0 \rfloor$, the matrix $\prod_{k=0}^{n-1} (\text{Id} - \varepsilon R + R_{\varepsilon,k})$ belongs to U , and:

$$\left\| \ln \left(\prod_{k=0}^{n-1} (\text{Id} - \varepsilon R + R_{\varepsilon,k}) \right) + n\varepsilon R \right\| \leq (1 + Kn\varepsilon)\omega'(\varepsilon) \frac{(1 + 2K\varepsilon)^n - 1}{2K\varepsilon}. \quad (2.9)$$

The claim is true for $n = 0$, as the left-hand side vanishes. Assume that the claim holds for some $n \leq \lfloor \varepsilon^{-1}t_0 \rfloor - 1$, and put:

$$S_{\varepsilon,n} := \ln \left(\prod_{k=0}^{n-1} (\text{Id} - \varepsilon R + R_{\varepsilon,k}) \right) + n\varepsilon R.$$

Define in the same way $S_{\varepsilon,n+1}$. We assume without loss of generality that ε is small enough that $\omega'(\varepsilon) \leq \varepsilon$. By Lemma 2.7,

$$\begin{aligned} \|S_{\varepsilon,n+1}\| &= \left\| \ln \left(\prod_{k=0}^n (\text{Id} - \varepsilon R + R_{\varepsilon,k}) \right) + (n+1)\varepsilon R \right\| \\ &= \left\| \ln \left(e^{-\varepsilon R + R'_{\varepsilon,n}} e^{-n\varepsilon R + S_{\varepsilon,n}} \right) + (n+1)\varepsilon R \right\| \\ &\leq \left\| -\varepsilon R + R'_{\varepsilon,n} - n\varepsilon R + S_{\varepsilon,n} + (n+1)\varepsilon R \right\| + C \left\| [-\varepsilon R + R'_{\varepsilon,n}, -n\varepsilon R + S_{\varepsilon,n}] \right\| \\ &\leq \|R'_{\varepsilon,n}\| + \|S_{\varepsilon,n}\| + 2C \left(\varepsilon \|R\| \|S_{\varepsilon,n}\| + \|R'_{\varepsilon,n}\| \|S_{\varepsilon,n}\| + n\varepsilon \|R'_{\varepsilon,n}\| \|R\| \right) \\ &\leq \omega'(\varepsilon) + \|S_{\varepsilon,n}\| + K\varepsilon \|S_{\varepsilon,n}\| + Kn\varepsilon\omega'(\varepsilon) + K\omega'(\varepsilon) \|S_{\varepsilon,n}\| \\ &\leq (1 + 2K\varepsilon) \|S_{\varepsilon,n}\| + (1 + Kn\varepsilon)\omega'(\varepsilon). \end{aligned}$$

Using the recursion hypothesis, we get:

$$\begin{aligned} \|S_{\varepsilon,n+1}\| &\leq (1 + 2K\varepsilon)(1 + Kn\varepsilon)\omega'(\varepsilon) \frac{(1 + 2K\varepsilon)^n - 1}{2K\varepsilon} + (1 + Kn\varepsilon)\omega'(\varepsilon) \\ &\leq (1 + K(n+1)\varepsilon)\omega'(\varepsilon) \frac{(1 + 2K\varepsilon)^{n+1} - 1}{2K\varepsilon}. \end{aligned}$$

Hence, we get the bound we want on $S_{\varepsilon, n+1}$. In addition, $n+1 \leq \lfloor \varepsilon^{-1} t_0 \rfloor$, so that:

$$\|S_{\varepsilon, n+1}\| \leq (1 + Kt_0) e^{2Kt_0} \frac{\omega'(\varepsilon)}{2K\varepsilon},$$

which converges to 0 uniformly for $1 \leq n+1 \leq \lfloor \varepsilon^{-1} t_0 \rfloor$. In particular, if ε is small enough (depending on t_0 but not on n), $S_{\varepsilon, n+1}$ belongs to U . This finishes the proof of our intermediate claim.

As a consequence, for all small enough ε and all $t \in [0, t_0]$, the matrix $M_\varepsilon(t)$ belongs to U and satisfies the inequality:

$$\|M_\varepsilon(t) - e^{-tR}\| \leq (1 + Kt_0) e^{2Kt_0} \frac{\omega'(\varepsilon)}{2K\varepsilon} + \|e^{-tR}\| \max_{s \in [0, \varepsilon]} \|e^{sR} - \text{Id}\|,$$

where the right-hand side converges to 0 when ε vanishes. The family of functions $(F_\varepsilon)_{\varepsilon > 0}$ thus converges to $t \mapsto e^{-tR}$ uniformly on $[0, t_0]$. In addition, since the error term only depends on $(R_{\varepsilon, n})_{\varepsilon > 0, n \geq 0}$ through ω , so the convergence is uniform in $(R_{\varepsilon, n})_{\varepsilon > 0, n \geq 0}$ at fixed ω .

Finally, let $T > 0$. Divide the interval $[0, T]$ into a finite number of subintervals of length less than t_0 , taking an increasing sequence $0 = s_0 < s_1 < \dots < s_\ell = T$ with $s_{i+1} - s_i < t_0$. On each such subinterval, the intermediate claim yields:

$$\lim_{\varepsilon \rightarrow 0} \sup_{s \in [s_i, s_{i+1}]} \|M_\varepsilon(s) M_\varepsilon(s_i)^{-1} - e^{-(s-s_i)R}\| = 0.$$

The concatenation of these bounds for $0 \leq i \leq \ell$ yields the uniform convergence of M_ε on $[0, T]$, and ends the proof of Lemma 2.8. \square

Remark 2.9.

If the family $(R_{\varepsilon, n})_{\varepsilon > 0, n \geq 0}$ does not depend on n , which in our future application is the case for random walks, then the conclusion of Lemma 2.8 follows directly from the identity

$$M_\varepsilon(t) = e^{\lfloor \varepsilon^{-1} t \rfloor \ln(\text{Id} - \varepsilon R + R_{\varepsilon, 0})},$$

and the fact that $\ln(\text{Id} - \varepsilon R + R_{\varepsilon, 0}) = \text{Id} - \varepsilon R + o(\varepsilon)$.

2.3 Cone contraction at time scale $\Theta(\varepsilon^{-1})$

In this subsection we prove Lemma 1.19. Let us recall briefly the strategy: thanks to the stability estimates of Subsection 2.1, in particular Corollary 2.6, and to Lemma 2.8, we shall prove that, for all piecewise constant f ,

$$\lim_{\varepsilon \rightarrow 0} \mathcal{L}_\varepsilon^{\lfloor \varepsilon^{-1} t \rfloor} f = e^{-t(tR)} f.$$

Then, a coupling argument referenced at the start of the section (for similar arguments, see e.g. [35, Chapter 5] in the context of Markov chains, and [10] in the context of hyperbolic dynamics and standard pairs) yields tension: for some constants $C, c > 0$, if in addition $\int_{[I]} f \, d\mu_I = 0$, then

$$\left\| \mathcal{L}_\varepsilon^{\lfloor \varepsilon^{-1} t \rfloor} f \right\|_\infty \leq C e^{-ct} \|f\|_\infty.$$

Integrating over $t \geq 0$ then relates $(\text{Id} - \mathcal{L}_\varepsilon)^{-1}$, and thus Q_ε , with R_0^{-1} .

Remark 2.10 (Perturbative argument and the spectrum of \mathcal{L}_ε).

As already mentioned, another direction of attack for this problem is to try and adapt the perturbative methods of G. Keller and C. Liverani [29], in particular in the form used by D. Dolgopyat and P. Wright [17]. In this setting, one views \mathcal{L}_ε as a perturbation of

$$\mathcal{L}_{[0]}^{\oplus |I|} : \begin{cases} \mathcal{B}_I & \rightarrow \mathcal{B}_I \\ (f(\cdot, i))_{i \in I} & \mapsto (\mathcal{L}_{[0]}(f(\cdot, i)))_{i \in I} \end{cases},$$

whose spectrum $\text{Sp}(\mathcal{L}_{[0]}^{\oplus |I|} \curvearrowright \mathcal{B}_I)$ is a $|I|$ -fold copy of $\text{Sp}(\mathcal{L}_{[0]} \curvearrowright \mathcal{B})$.

This approach is likely to give a more accurate description of \mathcal{L}_ε , although with no incidence on Theorem 0.1. For instance, under Hypothesis 1.18, we can hope to get an eigendecomposition

$$\mathcal{L}_\varepsilon = \mathcal{M}_\varepsilon + \mathcal{N}_\varepsilon,$$

with $\|\mathcal{M}_\varepsilon^n\|_{\mathcal{B}_I} \leq Ce^{-cn}$ for some $C, c > 0$ and all $\varepsilon > 0$, and \mathcal{N}_ε of finite rank, and almost conjugated with $(\text{Id} - \varepsilon^t R)$. In particular, the spectrum of \mathcal{N}_ε should be $o(\varepsilon)$ -close to that of $(\text{Id} - \varepsilon^t R)$, with eigenfunctions close to those of $\Pi^{*t} R \Pi_*$. If this holds, the bound of Equation 2.14 below may be improved to

$$\|\mathcal{L}_\varepsilon^n(f)\|_{\mathcal{B}_{I,0}} \leq Ce^{-\rho \varepsilon n} \|f\|_{\mathcal{B}_{I,0}},$$

with $\rho < \rho_R$ and C depends only on ρ .

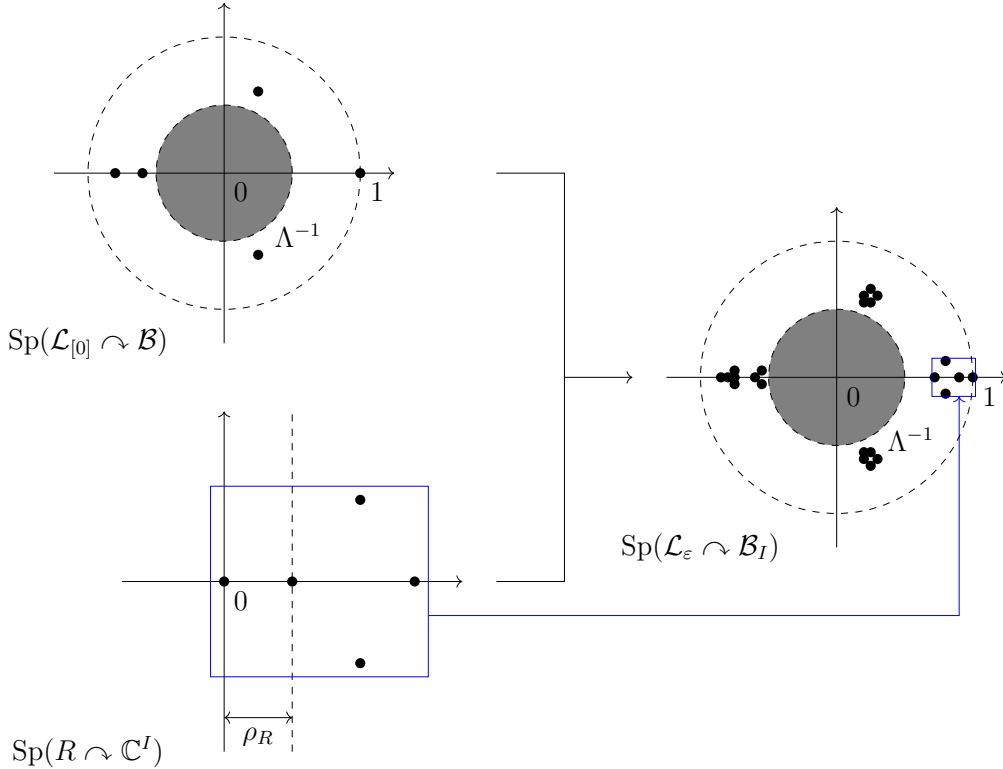

Figure 4: Conjectural picture for the relationship between the spectra of $\mathcal{L}_{[0]}$, R and \mathcal{L}_ε with $|I| = 5$. The spectrum of \mathcal{L}_ε is a perturbation of magnitude $\Theta(\varepsilon)$ of a five-fold copy of $\text{Sp}(\mathcal{L}_{[0]} \curvearrowright \mathcal{B})$, and the spectrum of R can be recovered by zooming in a window of size ε around $1 \in \text{Sp}(\mathcal{L}_\varepsilon \curvearrowright \mathcal{B}_I)$, then applying a central symmetry.

Let us finally mention the recent work of H. Tanaka [50], who recently investigated such multidimensional spectral degenerescences in the context of equilibrium measures of subshifts of finite type.

Our first step is to show that we can indeed apply Lemma 2.8 in our context.

Proposition 2.11.

Assume Hypotheses 1.2, 1.18 and 1.10.

For all $K \geq 0$, there exists a nonnegative function ω such that $\omega(\varepsilon) =_{\varepsilon \rightarrow 0} o(\varepsilon)$, and with the following property.

Let $(f_\varepsilon)_{\varepsilon > 0}$ be a family of functions from $[I]$ to \mathbb{R}_+ such that $f_\varepsilon \in C_K(\varepsilon)$ for all small enough ε . Then there exists a sequence of square matrices $(R_{\varepsilon,n})_{\varepsilon > 0, n \geq 0}$ such that

$$\sup_{n \geq 0} \|R_{\varepsilon,n}\| \leq \omega(\varepsilon)$$

and, for all $n \geq 0$,

$$\Pi_* \mathcal{L}_\varepsilon^{n+1} f_\varepsilon = (\text{Id} - \varepsilon({}^t R) + R_{\varepsilon,n})(\Pi_* \mathcal{L}_\varepsilon^n f_\varepsilon).$$

Proof. Let $K \geq 0$ and $(f_\varepsilon)_{\varepsilon > 0}$ be as in the hypotheses of Proposition 2.11. Without loss of generality, we assume that $K \geq K_1$, where K_1 is given by Corollary 2.6. By Corollary 2.6, there exists $\lambda_1 \geq 1$ such that $\mathcal{L}_\varepsilon^n f_\varepsilon \in C_{\lambda_1 K}(\varepsilon)$ for all small enough ε . Since $\mathcal{L}_\varepsilon^n f_\varepsilon \in C_{\lambda_1 K}(\varepsilon)$ and $\|\mathcal{L}_\varepsilon^n f_\varepsilon\|_{\mathbb{L}^1([I], \mu_I)} = \|f_\varepsilon\|_{\mathbb{L}^1([I], \mu_I)}$,

$$\|(\text{Id} - \Pi^* \Pi_*) \mathcal{L}_\varepsilon^n f_\varepsilon\|_\infty \leq \lambda_1 K \varepsilon \|f_\varepsilon\|_{\mathbb{L}^1([I], \mu_I)}. \quad (2.10)$$

Set $g_{\varepsilon,n} := (\text{Id} - \Pi^* \Pi_*) \mathcal{L}_\varepsilon^n f_\varepsilon$. By construction, $\Pi_* g_{\varepsilon,n} = 0$. For all $i, j \in I$,

$$\left| \int_{[j]} g_{\varepsilon,n} \cdot \mathbf{1}_{[j]} \circ T_\varepsilon \, d\mu \right| \leq \|g_{\varepsilon,n}\|_\infty \mu(x \in A : T_\varepsilon(x, i) \in [j]) = \|g_{\varepsilon,n}\|_\infty P_{\varepsilon,ij}.$$

Since \mathcal{L}_ε preserves μ_I , for all $i \in I$,

$$\begin{aligned} \int_{[i]} \mathcal{L}_\varepsilon(g_{\varepsilon,n}) \, d\mu &= |I| \int_{[I]} \mathbf{1}_{[i]} \mathcal{L}_\varepsilon(g_{\varepsilon,n}) \, d\mu_I \\ &= |I| \int_{[I]} g_{\varepsilon,n} \cdot \mathbf{1}_{[i]} \circ T_\varepsilon \, d\mu_I \\ &= \sum_{j \in I} \int_{[j]} g_{\varepsilon,n} \cdot \mathbf{1}_{[i]} \circ T_\varepsilon \, d\mu - \sum_{j \in I} \int_{[i]} g_{\varepsilon,n} \cdot \mathbf{1}_{[j]} \circ T_\varepsilon \, d\mu \\ &= \int_{[i]} g_{\varepsilon,n} \, d\mu + \sum_{j \neq i} \left(\int_{[j]} g_{\varepsilon,n} \cdot \mathbf{1}_{[i]} \circ T_\varepsilon \, d\mu - \int_{[i]} g_{\varepsilon,n} \cdot \mathbf{1}_{[j]} \circ T_\varepsilon \, d\mu \right), \end{aligned}$$

so that, by Equation (2.10),

$$\begin{aligned} \left| \int_{[i]} \mathcal{L}_\varepsilon(g_{\varepsilon,n}) \, d\mu - \int_{[i]} g_{\varepsilon,n} \, d\mu \right| &\leq \|g_{\varepsilon,n}\|_\infty \sum_{j \neq i} (P_{\varepsilon,ij} + P_{\varepsilon,ji}) \\ &\leq \lambda_1 K \varepsilon \|\mathcal{L}_\varepsilon^n f_\varepsilon\|_{\mathbb{L}^1([I], \mu_I)} O(\varepsilon). \end{aligned}$$

Since $\Pi_* g_{\varepsilon,n} = 0$, this later inequality can be read as $\|\Pi_* \mathcal{L}_\varepsilon g_{\varepsilon,n}\|_\infty = KO(\varepsilon^2) \|\mathcal{L}_\varepsilon^n f_\varepsilon\|_{\mathbb{L}^1([I], \mu_I)}$.

Recall that ${}^tP_\varepsilon = \Pi_* \mathcal{L}_\varepsilon \Pi^*$. We apply $\Pi_* \mathcal{L}_\varepsilon$ to $g_{\varepsilon,n}$:

$$\Pi_* \mathcal{L}_\varepsilon^{n+1} f_\varepsilon = {}^tP_\varepsilon \Pi_* \mathcal{L}_\varepsilon^n f_\varepsilon + \Pi_* \mathcal{L}_\varepsilon g_{\varepsilon,n} = (\text{Id} - \varepsilon({}^tR) + o(\varepsilon)) \Pi_* \mathcal{L}_\varepsilon^n f_\varepsilon + KO(\varepsilon^2) \|\mathcal{L}_\varepsilon^n f_\varepsilon\|_{\mathbb{L}^1([I], \mu_I)}.$$

As f_ε is nonnegative, $\|\mathcal{L}_\varepsilon^n f_\varepsilon\|_{\mathbb{L}^1([I], \mu_I)} = \|\Pi_* \mathcal{L}_\varepsilon^n f_\varepsilon\|_{\ell^1(I)}$, so that

$$\Pi_* \mathcal{L}_\varepsilon^{n+1} f_\varepsilon = (\text{Id} - \varepsilon({}^tR) + o(\varepsilon) + KO(\varepsilon^2)) \Pi_* \mathcal{L}_\varepsilon^n f_\varepsilon,$$

and the error term $o(\varepsilon) + KO(\varepsilon^2)$ only depends on K . \square

Our proximate goal is to understand the sequence $(\mathcal{L}_\varepsilon^n f_\varepsilon)_{n \geq 0}$ when f_ε has average 0. In order to apply Proposition 2.11, we shall write a function with average 0 as the difference of two functions in $C_K(\varepsilon)$. This can be efficiently formalized by introducing an auxiliary family of norms on \mathcal{B}_I .

Let $K, \varepsilon > 0$. Given a real function $f \in \mathcal{B}_I$, we define its (K, ε) -norm as

$$\|f\|_{K,\varepsilon} := \inf_{\substack{f_+, f_- \in C_K(\varepsilon) \\ f = f_+ - f_-}} \max\{\|f_+\|_{\mathbb{L}^1([I], \mu_I)}, \|f_-\|_{\mathbb{L}^1([I], \mu_I)}\}.$$

For complex-valued $f \in \mathcal{B}_I$, we put $\|f\|_{K,\varepsilon} := \max\{\|\Re f\|_{K,\varepsilon}, \|\Im f\|_{K,\varepsilon}\}$. For instance, if $f \in \mathcal{B}_{I,0}$ is constant on each $[i]$, then $\|f\|_{K,\varepsilon} = \max\{\|\Re f\|_{\mathbb{L}^1([I], \mu_I)}, \|\Im f\|_{\mathbb{L}^1([I], \mu_I)}\}/2$.

Lemma 2.12.

For any $K, \varepsilon > 0$, the (K, ε) -norm is equivalent to the \mathcal{B}_I -norm.

Proof. Let $K, \varepsilon > 0$.

Let $f \in \mathcal{B}_I$ with $\|f\|_{K,\varepsilon} < +\infty$. Assume that f is real-valued. Let $\delta > 0$, and write $f = f_+ - f_-$ with $\|f_+\|_{\mathbb{L}^1}, \|f_-\|_{\mathbb{L}^1} \leq \|f\|_{K,\varepsilon} + \delta$, and $f_+, f_- \in C_K(\varepsilon)$. Then $\|(\text{Id} - \Pi^* \Pi_*) f_+\|_{\mathcal{B}_I} \leq K\varepsilon \|f_+\|_{\mathbb{L}^1}$, so that, by Lemma 2.4,

$$\|f_+\|_{\mathcal{B}_I} \leq (|I| + K\varepsilon) \|f_+\|_{\mathbb{L}^1([I], \mu_I)} \leq (|I| + K\varepsilon) (\|f\|_{K,\varepsilon} + \delta)$$

and similarly for f_- . Hence, $\|f\|_{\mathcal{B}_I} \leq 2(|I| + K\varepsilon) (\|f\|_{K,\varepsilon} + \delta)$. Since this is true for all $\delta > 0$, we get $\|f\|_{\mathcal{B}_I} \leq 2(|I| + K\varepsilon) \|f\|_{K,\varepsilon}$. If f is complex-valued, by taking real and imaginary parts, we get

$$\|f\|_{\mathcal{B}_I} \leq 4(|I| + K\varepsilon) \|f\|_{K,\varepsilon}. \quad (2.11)$$

Let $f \in \mathcal{B}_I$ be real. Let $C := 1 + 2/(K\varepsilon)$. We choose $f_+ := f + C \|f\|_{\mathcal{B}_I}$ and $f_- := C \|f\|_{\mathcal{B}_I}$. Then $f_- \in C_0(\varepsilon)$ and

$$\frac{2 \|f\|_{\mathcal{B}_I}}{K\varepsilon} \leq f_+ \leq \frac{2(1 + K\varepsilon) \|f\|_{\mathcal{B}_I}}{K\varepsilon}.$$

We deduce from the lower bound on f_+ :

$$\|(\text{Id} - \Pi^* \Pi_*) f_+\|_{\mathcal{B}_I} = \|(\text{Id} - \Pi^* \Pi_*) f\|_{\mathcal{B}_I} \leq 2 \|f\|_{\mathcal{B}_I} \leq K\varepsilon \|f_+\|_{\mathbb{L}^1([I], \mu_I)}.$$

Hence $f_+ \in C_K(\varepsilon)$. Using the upper bound on f_+ ,

$$\|f_+\|_{\mathbb{L}^1([I], \mu_I)} \leq \frac{2(1 + K\varepsilon)}{K\varepsilon} \|f\|_{\mathcal{B}_I}.$$

Doing the same with the imaginary part of f finally yields:

$$\|f\|_{K,\varepsilon} \leq \frac{2(1 + K\varepsilon)}{K\varepsilon} \|f\|_{\mathcal{B}_I}. \quad \square$$

Thanks to Lemma 2.8, we now apply Proposition 2.11.

Corollary 2.13.

Assume Hypotheses 1.2, 1.18 and 1.10.

Let $K, C, T > 0$.

Let $(f_\varepsilon)_{\varepsilon>0}$ be a family of functions in \mathcal{B}_I . Assume that $\sup_{\varepsilon>0} \|f_\varepsilon\|_{K,\varepsilon} \leq C$. Then

$$\lim_{\varepsilon \rightarrow 0} \sup_{t \in [0, T]} \left\| \Pi_* \mathcal{L}_\varepsilon^{\lfloor \varepsilon^{-1} t \rfloor} f_\varepsilon - e^{-t({}^t R)} \Pi_* f_\varepsilon \right\|_{\ell^1(I)} = 0, \quad (2.12)$$

where the convergence is uniform for fixed K and C .

Proof. Let $K, C, T > 0$. Let $(f_\varepsilon)_{\varepsilon>0}$ be a family of functions in \mathcal{B}_I such that $\sup_{\varepsilon>0} \|f_\varepsilon\|_{K,\varepsilon} \leq C$.

Let (ε_k) be a positive sequence converging to 0. For all k , there exist $f_{k,+}, f_{k,-}, f_{k,i+}, f_{k,i-}$ in $C_K(\varepsilon)$ such that $f_{\varepsilon_k} = f_{k,+} - f_{k,-} + i f_{k,i+} - i f_{k,i-}$ and $\|f_{k,+}\|_{\mathbb{L}^1([I], \mu_I)} \leq 2C$, and likewise for $f_{k,-}, f_{k,i+}, f_{k,i-}$.

Note that

$$\begin{aligned} & \sup_{t \in [0, T]} \left\| \Pi_* \mathcal{L}_\varepsilon^{\lfloor \varepsilon^{-1} t \rfloor} f_{k,+} - e^{-t({}^t R)} \Pi_* f_{k,+} \right\|_{\ell^1(I)} \\ & \leq \sup_{t \in [0, T]} \left\| \prod_{n=0}^{\lfloor \varepsilon^{-1} t \rfloor - 1} (\text{Id} - \varepsilon_k ({}^t R) + R_{\varepsilon_k, n}) - e^{-t({}^t R)} \right\|_{\ell^1(I) \rightarrow \ell^1(I)} \| \Pi_* f_{k,+} \|_{\ell^1(I)}, \end{aligned}$$

where $(R_{\varepsilon_k, n})_{k, n \geq 0}$ is a sequence of matrices obtained by Proposition 2.11. The quantity $\| \Pi_* f_{k,+} \|_{\ell^1(I)}$ is equal to $|I| \cdot \|f_{k,+}\|_{\mathbb{L}^1([I], \mu_I)}$, and thus is bounded by $2C|I|$. By Lemma 2.8,

$$\lim_{k \rightarrow +\infty} \sup_{t \in [0, T]} \left\| \Pi_* \mathcal{L}_\varepsilon^{\lfloor \varepsilon^{-1} t \rfloor} f_{k,+} - e^{-t({}^t R)} \Pi_* f_{k,+} \right\|_{\ell^1(I)} = 0,$$

where the convergence is uniform in C . The same holds for $f_{k,-}, f_{k,i+}, f_{k,i-}$. Summing all four limits yields

$$\lim_{k \rightarrow +\infty} \sup_{t \in [0, T]} \left\| \Pi_* \mathcal{L}_\varepsilon^{\lfloor \varepsilon^{-1} t \rfloor} f_{\varepsilon_k} - e^{-t({}^t R)} \Pi_* f_{\varepsilon_k} \right\|_{\ell^1(I)} = 0.$$

Since the subsequence (ε_k) is arbitrary, this finishes the proof. \square

Corollary 2.13 gives us convergence of $\mathcal{L}_\varepsilon^{\lfloor \varepsilon^{-1} t \rfloor} f_\varepsilon$ to $e^{-t({}^t R)} \Pi_* f_\varepsilon$, in a relatively weak sense, but uniformly on all compacts in t . As announced, we now implement a coupling argument to show that $(\mathcal{L}_\varepsilon^{\lfloor \varepsilon^{-1} t \rfloor} f_\varepsilon)_{t \geq 0, \varepsilon > 0}$ is exponentially tight.

Proposition 2.14.

Assume Hypotheses 1.2, 1.18 and 1.10.

For any $\rho \in (0, \rho_R)$ and $K \geq 0$, there exist constants $C, \varepsilon_0 > 0$ such that, for all $\varepsilon \leq \varepsilon_0$ and $n \geq 0$, the operator norm of $\mathcal{L}_\varepsilon^n$ acting on $(\mathcal{B}_{I,0}, \|\cdot\|_{K,\varepsilon})$ is no larger than $Ce^{-\rho \varepsilon n}$.

Proof. Let $\rho' \in (\rho, \rho_R)$. Since R is an irreducible bi-L-matrix, so is tR . By Lemma 1.9, there exists a constant C such that, for all $t \geq 0$,

$$\left\| e^{-t({}^tR)} - \pi \right\|_{\ell^1(I) \rightarrow \ell^1(I)} \leq C e^{-\rho' t},$$

where $\pi(F) = |I|^{-1} (\sum_I F) \mathbf{1}$ is the eigenprojection associated with the eigenvalue 0 of tR .

Let $\sigma \in (0, 1)$, to be fixed at the end of this proof. Let K_σ and n_σ be given by Lemma 2.5. Let $T > 0$ be such that $C|I|e^{-\rho'T} \leq \sigma/3$. We assume without loss of generality that $K \geq K_\sigma$.

A renormalization map

Given $f_+ \in C_K(\varepsilon)$, we define :

$$\Phi_{\sigma, \varepsilon}(f_+) := \sigma^{-1} \left(\mathcal{L}_\varepsilon^{[\varepsilon^{-1}T]} f_+ - (1 - \sigma) \int_{[I]} f_+ d\mu_I \right).$$

Our intermediate goal is to prove that $\Phi_{\sigma, \varepsilon}$ maps $C_K(\varepsilon)$ into itself if ε is small enough.

Let $C' > 0$. Let $(\varepsilon_k)_{k \geq 0}$ be a sequence of positive numbers converging to 0, and $(f_{k,+})_{k \geq 0} \in C_K(\varepsilon_k)$ with $\|f_{k,+}\|_{\mathbb{L}^1([I], \mu_I)} \leq C'$. By Corollary 2.13,

$$\lim_{k \rightarrow +\infty} \sup_{t \in [0, T]} \left\| \Pi_* \mathcal{L}_{\varepsilon_k}^{[\varepsilon_k^{-1}t]} f_{k,+} - e^{-t({}^tR)} \Pi_* f_{k,+} \right\|_{\ell^1(I)} = 0,$$

uniformly for fixed K and C' . By our choice of T ,

$$e^{-T({}^tR)} \Pi_* f_{k,+} \geq \pi(\Pi_* f_{k,+}) - C e^{-\rho'T} \|\Pi_* f_{k,+}\|_{\ell^1(I)} \geq \left(1 - \frac{\sigma}{3}\right) \int_{[I]} f_{k,+} d\mu_I.$$

Hence, if k is large enough, then

$$\Pi_* \mathcal{L}_{\varepsilon_k}^{[\varepsilon_k^{-1}T]} f_{k,+} \geq \left(1 - \frac{2\sigma}{3}\right) \int_{[I]} f_{k,+} d\mu_I.$$

If k is large enough, then $\varepsilon_k^{-1}T \geq n_\sigma$, so that $\mathcal{L}_{\varepsilon_k}^{[\varepsilon_k^{-1}T]} f_{k,+} \in C_{\sigma K}(\varepsilon_k)$. This has two consequences. The first is that, if k is large enough,

$$\begin{aligned} \mathcal{L}_{\varepsilon_k}^{[\varepsilon_k^{-1}T]} f_{k,+} &\geq \Pi_* \mathcal{L}_{\varepsilon_k}^{[\varepsilon_k^{-1}T]} f_{k,+} - \sigma K \varepsilon_k \int_{[I]} f_{k,+} d\mu_I \\ &\geq (1 - \sigma) \int_{[I]} f_{k,+} d\mu_I. \end{aligned}$$

In particular, $\Phi_{\sigma, \varepsilon_k}(f_{k,+}) \geq 0$. The second consequence is that, if k is large enough, then

$$\begin{aligned} \|(\text{Id} - \Pi^* \Pi_*) \Phi_{\sigma, \varepsilon_k}(f_{k,+})\|_{\mathcal{B}_I} &= \sigma^{-1} \left\| (\text{Id} - \Pi^* \Pi_*) \mathcal{L}_{\varepsilon_k}^{[\varepsilon_k^{-1}T]} f_{k,+} \right\|_{\mathcal{B}_I} \\ &\leq \sigma^{-1} \sigma K \varepsilon_k \left\| \mathcal{L}_{\varepsilon_k}^{[\varepsilon_k^{-1}T]} f_{k,+} \right\|_{\mathbb{L}^1([I], \mu_I)} \\ &= K \varepsilon_k \|\Phi_{\sigma, \varepsilon_k}(f_{k,+})\|_{\mathbb{L}^1([I], \mu_I)}. \end{aligned}$$

Hence, $\Phi_{\sigma,\varepsilon_k}(f_{k,+}) \in C_K(\varepsilon_k)$. Since $\Phi_{\sigma,\varepsilon_k}$ is linear, $\Phi_{\sigma,\varepsilon_k}(C_K(\varepsilon_k)) \subset C_K(\varepsilon_k)$ for all large enough k . Finally, since $(\varepsilon_k)_{k \geq 0}$ is arbitrary, $\Phi_{\sigma,\varepsilon}(C_K(\varepsilon)) \subset C_K(\varepsilon)$ for all small enough ε .

Bound on the operator norm

Let ε be small enough that $\Phi_{\sigma,\varepsilon}$ preserves $C_K(\varepsilon)$. Let $f \in \mathcal{B}_{I,0}$, which we assume without loss of generality to be real. Let $f_+, f_- \in C_K(\varepsilon)$ be such that $f = f_+ - f_-$ and $\|f_+\|_{\mathbb{L}^1([I],\mu_I)}, \|f_-\|_{\mathbb{L}^1([I],\mu_I)} \leq 2\|f\|_{K,\varepsilon}$. Then

$$\begin{aligned} \mathcal{L}_\varepsilon^{\lfloor \varepsilon^{-1}T \rfloor} f &= \mathcal{L}_\varepsilon^{\lfloor \varepsilon^{-1}T \rfloor} f_+ - \mathcal{L}_\varepsilon^{\lfloor \varepsilon^{-1}T \rfloor} f_- \\ &= \left(\mathcal{L}_\varepsilon^{\lfloor \varepsilon^{-1}T \rfloor} f_+ - (1-\sigma) \int_{[I]} f_+ d\mu_I \right) - \left(\mathcal{L}_\varepsilon^{\lfloor \varepsilon^{-1}T \rfloor} f_- - (1-\sigma) \int_{[I]} f_- d\mu_I \right) \\ &= \sigma (\Phi_{\sigma,\varepsilon}(f_+) - \Phi_{\sigma,\varepsilon}(f_-)). \end{aligned}$$

By recursion, we get, for all $m \geq 0$:

$$\mathcal{L}_\varepsilon^{m \lfloor \varepsilon^{-1}T \rfloor} f = \sigma^m (\Phi_{\sigma,\varepsilon}^m(f_+) - \Phi_{\sigma,\varepsilon}^m(f_-)).$$

The functions $\Phi_{\sigma,\varepsilon}^m(f_+)$ and $\Phi_{\sigma,\varepsilon}^m(f_-)$ belong to $C_K(\varepsilon)$ and have the same integral as f_+ .

Let $k \geq 0$. By Corollary 2.6, without loss of generality, there exists a constant $\lambda_1 \geq 1$ such that, and all $\varepsilon > 0, k \geq 0$, the functions $\mathcal{L}_\varepsilon^k \Phi_{\sigma,\varepsilon}^m(f_+)$ and $\mathcal{L}_\varepsilon^k \Phi_{\sigma,\varepsilon}^m(f_-)$ belong to $C_{\lambda_1 K}(\varepsilon)$. Hence, setting

$$\tilde{f}_+ := (\lambda_1 - 1) \|f_+\|_{\mathbb{L}^1([I],\mu_I)} + \mathcal{L}_\varepsilon^k \Phi_{\sigma,\varepsilon}^m(f_+)$$

and likewise for f_- ,

$$\mathcal{L}_\varepsilon^{m \lfloor \varepsilon^{-1}T \rfloor + k} f = \sigma^m (\tilde{f}_+ - \tilde{f}_-).$$

By construction,

$$\begin{aligned} \left\| (\text{Id} - \Pi^* \Pi_*) \tilde{f}_+ \right\|_{\mathcal{B}_I} &= \left\| (\text{Id} - \Pi^* \Pi_*) \mathcal{L}_\varepsilon^k \Phi_{\sigma,\varepsilon}^m(f_+) \right\|_{\mathcal{B}_I} \\ &\leq \lambda_1 K \varepsilon \left\| \mathcal{L}_\varepsilon^k \Phi_{\sigma,\varepsilon}^m(f_+) \right\|_{\mathbb{L}^1([I],\mu_I)} \\ &= \lambda_1 K \varepsilon \|f_+\|_{\mathbb{L}^1([I],\mu_I)} \\ &= K \varepsilon \left\| \tilde{f}_+ \right\|_{\mathbb{L}^1([I],\mu_I)}. \end{aligned}$$

Since the same estimate holds for \tilde{f}_- , the functions \tilde{f}_+, \tilde{f}_- belong to $C_K(\varepsilon)$ and their \mathbb{L}^1 -norm is bounded by $\lambda_1 \|f_+\|_{\mathbb{L}^1([I],\mu_I)} \leq 2\lambda_1 \|f\|_{K,\varepsilon}$. Hence,

$$\left\| \mathcal{L}_\varepsilon^{m \lfloor \varepsilon^{-1}T \rfloor + k} f \right\|_{K,\varepsilon} \leq 2\lambda_1 \sigma^m \|f\|_{K,\varepsilon}. \quad (2.13)$$

Let $n \geq 0$. Take $m := \lfloor \varepsilon T^{-1} n \rfloor$ and $k := n - m \lfloor \varepsilon^{-1}T \rfloor$. Equation (2.13) implies :

$$\left\| \mathcal{L}_\varepsilon^n f \right\|_{K,\varepsilon} \leq 2\lambda_1 \sigma^{\lfloor \varepsilon T^{-1} n \rfloor} \|f\|_{K,\varepsilon}.$$

Finally, recall that the only constraint on T is that $C|I|e^{-\rho'T} \leq \sigma/3$. Hence, we can take $T := \rho'^{-1} \lfloor \ln(\sigma/(3C|I|)) \rfloor$, so that:

$$\begin{aligned} \left\| \mathcal{L}_\varepsilon^n f \right\|_{K,\varepsilon} &\leq 2\lambda_1 e^{-\lfloor \ln(\sigma) \rfloor \lfloor \rho'\varepsilon \lfloor \ln(\sigma/(3C|I|)) \rfloor^{-1} n} \|f\|_{K,\varepsilon} \\ &\leq 2\lambda_1 \sigma^{-1} e^{-\rho' \frac{\ln(\sigma)}{\ln(\sigma) - \ln(3C|I|)} \varepsilon n} \|f\|_{K,\varepsilon}. \end{aligned}$$

Choose σ small enough that

$$\rho' \frac{\ln(\sigma)}{\ln(\sigma) - \ln(3C|I|)} \leq \rho \quad ;$$

then

$$\|\mathcal{L}_\varepsilon^n f\|_{K,\varepsilon} \leq 2\lambda_1 \sigma^{-1} e^{-\rho\varepsilon n} \|f\|_{K,\varepsilon}. \quad \square$$

Remark 2.15 (Bound in operator norm).

The bound on the operator norm of $\mathcal{L}_\varepsilon^n$ in Proposition 2.14 is given for the norm $\|\cdot\|_{K,\varepsilon}$. For the original Lipschitz norm $\|\cdot\|_{\mathcal{B}_I}$, which does not depend on ε , for any $\rho < \rho_R$, the bounds in the proof of Lemma 2.12 yield a constant C such that:

$$\|\mathcal{L}_\varepsilon^n\|_{\mathcal{B}_{I,0} \rightarrow \mathcal{B}_{I,0}} \leq \frac{C}{\varepsilon} e^{-\rho\varepsilon n}. \quad (2.14)$$

While not necessary for the remainder of this article, notice that Lemma 2.12 and Proposition 2.14 give an explicit lower bound on the spectral gap of \mathcal{L}_ε . By ergodicity of $([I], \mu_I, T_\varepsilon)$, the operator \mathcal{L}_ε has 1 as a simple eigenvalue, corresponding to constant eigenfunctions. Define the *spectral gap* of \mathcal{L}_ε acting on \mathcal{B}_I as, equivalently, one minus the spectral radius of \mathcal{L}_ε acting on $\mathcal{B}_{I,0}$, that is

$$\min\{1 - |\lambda| : \lambda \in \text{Sp}(\mathcal{L}_\varepsilon \curvearrowright \mathcal{B}_I), \lambda \neq 1\}.$$

Corollary 2.16.

Assume Hypotheses 1.2, 1.18 and 1.10.

When ε goes to 0, the spectral gap of \mathcal{L}_ε acting on \mathcal{B}_I is at least $\rho_R \varepsilon (1 - o(1))$.

Integrating over $t \geq 0$, we can now relate S with R_0^{-1} .

Corollary 2.17.

Assume Hypotheses 1.2, 1.18 and 1.10.

Let $K \geq 0$. Let $(f_\varepsilon)_{\varepsilon>0}$ be a family of functions in $\mathcal{B}_{I,0}$. Assume that $\sup_{\varepsilon>0} \|f_\varepsilon\|_{K,\varepsilon} < +\infty$. Then, in $\mathcal{B}_{I,0}$,

$$\sum_{n=0}^{+\infty} \mathcal{L}_\varepsilon^n f_\varepsilon = \frac{1}{\varepsilon} \Pi^* ({}^t R_0^{-1}) \Pi_* f_\varepsilon + o(\varepsilon^{-1}). \quad (2.15)$$

Proof. Changing the time scale by a factor of ε^{-1} , we get:

$$\sum_{n=0}^{+\infty} \mathcal{L}_\varepsilon^n f_\varepsilon = \frac{1}{\varepsilon} \int_0^{+\infty} \mathcal{L}_\varepsilon^{\lfloor \varepsilon^{-1} t \rfloor} f_\varepsilon dt.$$

By Corollary 2.13, on all compact subsets of \mathbb{R}_+ ,

$$\lim_{\varepsilon \rightarrow 0} \sup_{t \in [0, T]} \left\| \Pi_* \mathcal{L}_\varepsilon^{\lfloor \varepsilon^{-1} t \rfloor} f_\varepsilon - e^{-t({}^t R)} \Pi_* f_\varepsilon \right\|_{\ell^1(I)} = 0.$$

By Proposition 2.14, there exists a constant C such that $\left\| \mathcal{L}_\varepsilon^{\lfloor \varepsilon^{-1} t \rfloor} f_\varepsilon \right\|_{K,\varepsilon} \leq C \|f\|_{K,\varepsilon}$. We write $\mathcal{L}_\varepsilon^{\lfloor \varepsilon^{-1} t \rfloor} f_\varepsilon = f_+ - f_-$ with $f_+, f_- \in C_K(\varepsilon)$ and $\|f_+\|_{\mathbb{L}^1([I], \mu_I)}, \|f_-\|_{\mathbb{L}^1([I], \mu_I)} \leq 2 \|f\|_{K,\varepsilon}$. Up to taking a larger value of K , the function $\mathcal{L}_\varepsilon^{\lfloor \varepsilon^{-1} t \rfloor} f_+$ belongs to $C_{\lambda_1 K}(\varepsilon)$ for all t by Corollary 2.6. Hence,

$$\left\| (\text{Id} - \Pi^* \Pi_*) \mathcal{L}_\varepsilon^{\lfloor \varepsilon^{-1} t \rfloor} f_+ \right\|_{\mathcal{B}_I} \leq \lambda_1 K \varepsilon \left\| \mathcal{L}_\varepsilon^{\lfloor \varepsilon^{-1} t \rfloor} f_+ \right\|_{\mathbb{L}^1([I], \mu_I)} \leq 2\lambda_1 K \varepsilon \|f\|_{K,\varepsilon}.$$

The function f_- satisfies a similar estimate. It follows that

$$\left\| (\text{Id} - \Pi^* \Pi_*) \mathcal{L}_\varepsilon^{\lfloor \varepsilon^{-1} t \rfloor} f_\varepsilon \right\|_{\mathcal{B}_I} \leq 4\lambda_1 K \varepsilon \|f\|_{K, \varepsilon}.$$

Hence,

$$\lim_{\varepsilon \rightarrow 0} \sup_{t \in [0, T]} \left\| \mathcal{L}_\varepsilon^{\lfloor \varepsilon^{-1} t \rfloor} f_\varepsilon - \Pi^* e^{-t({}^t R)} \Pi_* f_\varepsilon \right\|_{\mathcal{B}_I} = 0. \quad (2.16)$$

In addition, by Proposition 2.14 again, there exist constants $C, \rho > 0$ such that the operator norm of $\mathcal{L}_\varepsilon^n$ acting on $(\mathcal{B}_{I,0}, \|\cdot\|_{K, \varepsilon})$ is no larger than $Ce^{-\rho \varepsilon n}$. Using Equation (2.11),

$$\left\| \mathcal{L}_\varepsilon^{\lfloor \varepsilon^{-1} t \rfloor} f_\varepsilon \right\|_{\mathcal{B}_I} \leq 4(1 + K\varepsilon) \left\| \mathcal{L}_\varepsilon^{\lfloor \varepsilon^{-1} t \rfloor} f_\varepsilon \right\|_{K, \varepsilon} \leq 4(1 + K\varepsilon) C e^{\rho \varepsilon} e^{-\rho t} \|f\|_{K, \varepsilon}.$$

This gives the tightness needed for the convergence of integrals:

$$\lim_{\varepsilon \rightarrow 0} \left\| \int_0^{+\infty} \mathcal{L}_\varepsilon^{\lfloor \varepsilon^{-1} t \rfloor} f_\varepsilon dt - \int_0^{+\infty} \Pi^* e^{-t({}^t R)} \Pi_* f_\varepsilon dt \right\|_{\mathcal{B}_I} = 0.$$

Finally, denoting by ${}^t R_0$ the action of ${}^t R$ on \mathbb{C}_0^I , to which $\Pi_* f_\varepsilon$ belongs,

$$\int_0^{+\infty} \Pi^* e^{-t({}^t R)} \Pi_* f_\varepsilon dt = \Pi^* \left(\int_0^{+\infty} e^{-t({}^t R_0)} dt \right) \Pi_* f_\varepsilon = \Pi^* ({}^t R_0^{-1}) \Pi_* f_\varepsilon.$$

We get the claim by multiplying both side by ε^{-1} :

$$\left\| \frac{1}{\varepsilon} \int_0^{+\infty} \mathcal{L}_\varepsilon^{\lfloor \varepsilon^{-1} t \rfloor} f_\varepsilon dt - \frac{1}{\varepsilon} \Pi^* ({}^t R_0^{-1}) \Pi_* f_\varepsilon \right\|_{\mathcal{B}_I} = o(\varepsilon^{-1}). \quad \square$$

We now finish the proof of Lemma 1.19.

Proof of Lemma 1.19. Given $f \in \mathbb{C}_0^I$, the quantity $\|\Pi^* f\|_{K, \varepsilon}$ is bounded jointly in K and ε , and Corollary 2.17 applies. By Lemma 1.14, ${}^t R_0^{-1}$ is irreducible in the sense of Definition 1.13. This yields, for all $f, g \in \mathbb{C}_0^I$,

$$\begin{aligned} \varepsilon^{-1} \langle f, S(g) \rangle_{\ell^2(I)} + o(\varepsilon^{-1}) &= \langle f, Q_\varepsilon(g) \rangle_{\ell^2(I)} \\ &= \langle \Pi_* (\text{Id} - \mathcal{L}_\varepsilon)^{-1} \Pi^*(f), g \rangle_{\ell^2(I)} \\ &= \varepsilon^{-1} \langle \Pi_* \Pi^* ({}^t R_0^{-1}) \Pi_* \Pi^*(f), g \rangle_{\ell^2(I)} + o(\varepsilon^{-1}) \\ &= \varepsilon^{-1} \langle f, R_0^{-1}(g) \rangle_{\ell^2(I)} + o(\varepsilon^{-1}), \end{aligned}$$

whence $S = R_0^{-1}$. □

3 The ergodic case

All the work in Section 2 was done under Hypothesis 1.18, that is, that the first return map $(A, \mu, T_{[0]})$ is mixing. This hypothesis is inconvenient, as we would like to work only with conditions involving the initial data: the system (A, μ, T) and the function F .

If $([\mathbb{Z}^d], \tilde{\mu}, \tilde{T})$ is recurrent and ergodic, then $(A, \mu, T_{[0]})$ is well-defined and ergodic. Hence, ergodicity comes freely, and we would like to use this property instead of the stronger mixing hypothesis. This is the goal of this section.

3.1 Structure of extensions with non-mixing first return maps

Let $([\mathbb{Z}^d], \tilde{\mu}, \tilde{T})$ be a Markov \mathbb{Z}^d -extension of a Gibbs-Markov map (A, α, d, μ, T) with jump function F . Assume that $([\mathbb{Z}^d], \tilde{\mu}, \tilde{T})$ is ergodic and recurrent. As the induced map $(A, \mu, T_{[0]})$ is well-defined and ergodic, by Corollary A.10, there exists an integer $M \geq 1$ and a partition $A = \bigsqcup_{\ell \in \mathbb{Z}/M\mathbb{Z}} A_\ell$ such that each A_ℓ is α^* -measurable, $T_{[0]}(A_\ell) \subset A_{\ell+1}$ for all ℓ , and $T_{[0]}^M : A_\ell \rightarrow A_\ell$ is mixing for all ℓ .

At first, we show the constraints that the existence of a non-trivial period for $(A, \mu, T_{[0]})$ impose on the whole extension $([\mathbb{Z}^d], \tilde{\mu}, \tilde{T})$. We introduce a colouration of $[\mathbb{Z}^d]$.

Definition 3.1 (Color of a site).

Let $([\mathbb{Z}^d], \tilde{\mu}, \tilde{T})$ be a Markov \mathbb{Z}^d -extension of a Gibbs-Markov map (A, α, d, μ, T) . Assume that $([\mathbb{Z}^d], \tilde{\mu}, \tilde{T})$ is ergodic and recurrent. Let $A = \bigsqcup_{\ell \in \mathbb{Z}/M\mathbb{Z}} A_\ell$ be the decomposition of $(A, \mu, T_{[0]})$ associated with its period M . For $\tilde{\mu}$ -almost every $(x, p) \in [\mathbb{Z}^d]$, let

$$\tilde{\varphi}_{[0]}(x, p) := \inf\{n \geq 1 : \tilde{T}^n(x, p) \in [0]\}. \quad (3.1)$$

The colour of (x, p) is defined as the element $\ell \in \mathbb{Z}/M\mathbb{Z}$ such that $\tilde{T}^{\tilde{\varphi}_{[0]}(x, p)}(x, p) \in A_\ell$. We shall denote it by $C(x, p)$.

Interestingly, the structural constraints we get are different depending on whether $d = 1$ or $d = 2$, the later case being simpler. As the following proposition states, in the $d = 2$ case, all sites have the same colour, up to a neighbourhood of $[0]$. In the $d = 1$ case, we may need two colours. This difference comes from the fact that the plane minus a point is connected, while the line minus a point has two connected components.

Proposition 3.2.

Let $([\mathbb{Z}^d], \tilde{\mu}, \tilde{T})$ be a Markov \mathbb{Z}^d -extension of a Gibbs-Markov map (A, α, d, μ, T) with jump function F . Assume that $([\mathbb{Z}^d], \tilde{\mu}, \tilde{T})$ is ergodic and recurrent.

If $d = 2$, or $d = 1$ and $\|F\|_{\mathbb{L}^\infty(A, \mu)} = +\infty$, then there exists $R > 0$ and $\ell \in \mathbb{Z}/M\mathbb{Z}$ such that $C(x, p) = \ell$ whenever $\|p\| \geq R$.

If $d = 1$ and $\|F\|_{\mathbb{L}^\infty(A, \mu)} < +\infty$, then there exists $R > 0$ and $\ell_-, \ell_+ \in \mathbb{Z}/M\mathbb{Z}$ (not necessarily distinct) such that $C(x, p) = \ell_-$ whenever $p \leq -R$ and $C(x, p) = \ell_+$ whenever $p \geq R$.

Proof. We work under the hypotheses of Proposition 3.2. First, let us note that $C \circ \tilde{T}(x, p) = C(x, p)$ for all $(x, p) \in [\mathbb{Z}^d] \setminus [0]$.

By ergodicity and recurrence, $[\mathbb{Z}^d]$ is swept by the forward images of $[0]$, that is,

$$[\mathbb{Z}^d] = \bigcup_{x \in A} \bigsqcup_{k=0}^{\varphi_{[0]}(x)-1} \tilde{T}^k(x, 0).$$

Let $\ell \in \mathbb{Z}/M\mathbb{Z}$. The property that $T_{[0]}(A_{\ell-1}) = A_\ell$ implies that, for all $x \in A_{\ell-1}$ and all $0 \leq k < \varphi_{[0]}(x)$,

$$\tilde{T}^{\tilde{\varphi}_{[0]}(\tilde{T}^k(x, 0))} \circ \tilde{T}^k(x, 0) = \tilde{T}^{\varphi_{[0]}(x)-k} \circ \tilde{T}^k(x, 0) = T_{[0]}(x) \in A_\ell,$$

so that $C(\tilde{T}^k(x, 0)) = \ell$. Doing this for all ℓ yields $\{C = \ell\} = \bigcup_{x \in A_{\ell-1}} \bigsqcup_{k=0}^{\varphi_{[0]}(x)-1} \tilde{T}^k(x, 0)$: modulo a negligible subset, the points of colour ℓ are exactly the forward images of $A_{\ell-1}$ up to time $\varphi_{[0]} - 1$.

Let $\ell \in \mathbb{Z}/M\mathbb{Z}$. We can also write the later fact as

$$\{C = \ell\} = \bigcup_{k=0}^{+\infty} \tilde{T}^k(A_{\ell-1} \cap \{\varphi_{[0]} > k\}).$$

Since $\varphi_{[0]}$ is a stopping time, $\{\varphi_{[0]} > k\}$ is $\sigma(\alpha^{(k)})$ -measurable. The set $A_{\ell-1}$ is also $\sigma(\alpha^*)$ -measurable by Corollary A.10, and thus also $\sigma(\alpha^{(k)})$ -measurable. The function $S_k F$ is constant on each cylinder of length k , so that we can write it as a function of the cylinder. Hence, setting $B(p, \ell) := \{x \in A : C(x, p) = \ell\}$, we have

$$B(p, \ell) = \bigcup_{k=0}^{+\infty} \bigsqcup_{\substack{a \in \alpha^{(k)} \\ a \subset A_{\ell-1} \cap \{\varphi_{[0]} > k\} \\ S_k(a) = p}} T^k(a). \quad (3.2)$$

By the big image property of Gibbs-Markov maps, for all $k \geq 0$ and nonempty $a \in \alpha^{(k)}$, we have $\mu(T^k(a)) \geq \delta_0 := \inf_{a \in \alpha} \mu(T(a)) > 0$. Each subset $T^k(a)$ in Equation (3.2) has measure at least δ_0 . Hence, for any $p \in \mathbb{Z}^d$ and $\ell \in \mathbb{Z}/M\mathbb{Z}$, we have a dichotomy:

- either $\mu(B(p, \ell)) = 0$;
- or $\mu(B(p, \ell)) \geq \delta_0 > 0$.

In other words, on each site, either a colour is absent, or it is present in a quantity of at least δ_0 .

Let $p \in \mathbb{Z}^d \setminus \{0\}$ and ℓ such that $\mu(B(p, \ell)) > 0$. From the expression in Equation (3.2), the set $B(p, \ell)$ is $\sigma(\alpha^*)$ -measurable, so that $\|\mathbf{1}_{B(p, \ell)}\|_{\mathcal{B}} = 1$. Since $T_{[0]}$ is ergodic, by Corollary A.10, there exists $M \geq 1$, $C > 0$ and $\rho \in (0, 1)$, independent from p and ℓ , such that

$$\left\| \frac{1}{M} \sum_{k=0}^{M-1} \mathcal{L}_{[0]}^{n+k}(\mathbf{1}_{B(p, \ell)}) - \mu(B(p, \ell)) \right\|_{\mathbb{L}^\infty} \leq C \rho^n \|\mathbf{1}_{B(p, \ell)}\|_{\mathcal{B}} = C \rho^n.$$

Hence, there exists $n_0 > 0$ such that $\sum_{k=0}^{n_0-1} \mathcal{L}_{[0]}^k(\mathbf{1}_{B(p, \ell)}) \geq \delta_0/2 > 0$ almost everywhere for all $p \in \mathbb{Z}^d \setminus \{0\}$ and ℓ such that $\mu(B(p, \ell)) > 0$. But the support of the function $\sum_{k=0}^{n_0-1} \mathcal{L}_{[0]}^k(\mathbf{1}_{B(p, \ell)})$ is $\bigcup_{k=0}^{n_0-1} T_{[0]}^k(B(p, \ell))$, so that, almost everywhere,

$$\bigcup_{k=0}^{n_0-1} T_{[0]}^k(B(p, \ell)) = A.$$

Let us define $\varphi_{[p] \rightarrow [0]}(x) := \inf\{n \geq 1 : T_{[\{p, 0\}]}^n(x, p) \in [0]\}$. Since the probability of hitting $[0]$ before going back to $[p]$ converges to 0 as p goes to infinity by [40, Lemma 4.17], the random variable $\varphi_{[p] \rightarrow [0]}$ converges in distribution to $+\infty$ when p goes to infinity. In particular, there exists $r_0 > 0$ such that $\mu(\varphi_{[p] \rightarrow [0]} < n_0) < \delta_0/n_0$ whenever $\|p\| > r_0$.

Assume that $\|p\| > r_0$. Then

$$\mu \left(\bigcup_{k=0}^{n_0-1} T_{[0]}^k(B(p, \ell) \cap \{\varphi_{[p] \rightarrow [0]} \geq n_0\}) \right) \geq 1 - n_0 \mu(\varphi_{[p] \rightarrow [0]} < n_0) > 1 - \delta_0.$$

In addition, for $x \in B(p, \ell) \cap \{\varphi_{[p] \rightarrow [0]} \geq n_0\}$ and $0 \leq k < n_0$, we have $C(T_{\{0, p\}}^k(x, p)) = C(x, p) = \ell$, and thus $\mu(B(p, \ell)) > 1 - \delta_0$. By the dichotomy on $\mu(B(p, \ell))$, we thus have $\mu(B(p, \ell')) = 0$ for $\ell' \neq \ell$, so that $\mu(B(p, \ell)) = 1$. In other words, if $\|p\| > r_0$, then $[p]$ is monochromatic.

Let \leftrightarrow be the nearest neighbor relation in \mathbb{Z}^d . For all $q \leftrightarrow 0$, the random variable $\varphi_{[p] \rightarrow [p+q]}$ does not depend on p , while $\varphi_{[p] \rightarrow [0]}$ converges in distribution to $+\infty$ as p goes to infinity. In particular, there exists r_1 such that $\mu(\varphi_{[p] \rightarrow [p+q]} < \varphi_{[p] \rightarrow [0]}) > 0$ for all $\|p\| > r_1$ and $q \leftrightarrow 0$.

Let $p \in \mathbb{Z}^d$ with $\|p\| > R := \max\{r_0 + 1, r_1\}$. Then $[p]$ is monochromatic; let ℓ be its colour. For each $p' \leftrightarrow p$, we have $\mu(\varphi_{[p] \rightarrow [p']} < \varphi_{[p] \rightarrow [0]}) > 0$, so that $[p']$ also contains the colour ℓ . But $\|p'\| > r_0$, so $[p']$ is also monochromatic, and thus is the same colour as $[p]$.

At this point, our conclusion depends on the dimension.

- For the case $d = 2$: the graph $\mathbb{Z}^2 \setminus B(0, R)$ is connected, so that $[\mathbb{Z}^2 \setminus B(0, R)]$ is monochromatic.
- For the case $d = 1$: the graph $\mathbb{Z} \setminus B(0, R)$ has two connected components, so that the sets $[(-\infty, -R) \cap \mathbb{Z}]$ and $[(R, +\infty) \cap \mathbb{Z}]$ are both monochromatic.

In the later case, assume furthermore that $\|f\|_{\mathbb{L}^\infty(A, \mu)} = +\infty$; without loss of generality, assume that the essential supremum of F is $+\infty$. Then there exists $p \in (-\infty, -R) \cap \mathbb{Z}$ and $q \in (R, +\infty) \cap \mathbb{Z}$ such that $\mu([p] \cap \tilde{T}^{-1}([q])) > 0$. In particular, $[p]$ and $[q]$ have the same colour, so $[\mathbb{Z} \setminus B(0, R)]$ is monochromatic. \square

Proposition 3.2 gives very strong constraints on the structure of a Markov \mathbb{Z}^d -extension whose induced map in $[0]$ is not mixing. We now prove that, under these constraints, the induced map $T_{[\Sigma]}$ itself has a decomposition in periodic components, as long as the elements of Σ are far enough apart.

Proposition 3.3.

Let $([\mathbb{Z}^d], \tilde{\mu}, \tilde{T})$ be a Markov \mathbb{Z}^d -extension of a Gibbs-Markov map (A, α, d, μ, T) with jump function F . Assume that $([\mathbb{Z}^d], \tilde{\mu}, \tilde{T})$ is ergodic and recurrent. Let $M \geq 1$ be the period of $([0], \mu, T_{[0]})$. Then there exists $R > 0$ with the following property. Let $\Sigma \subset \mathbb{Z}^d$ be non-empty and such that $\min_{p \neq q \in \Sigma} \|p - q\| \geq R$.

If $[\mathbb{Z}^d \setminus B(0, r)]$ is monochromatic for large enough r (and in particular if $d = 2$, or $d = 1$ and $\|F\|_{\mathbb{L}^\infty(A, \mu)} = +\infty$), then $T_{[\Sigma]}(A_k \times \Sigma) \subset A_{k+1} \times \Sigma$ for all $k \in \mathbb{Z}/M\mathbb{Z}$. In addition, there exists $\ell \in \mathbb{Z}/M\mathbb{Z}$ such that, almost surely, transitions between sites occur only from $A_{\ell-1} \times \Sigma$ to $A_\ell \times \Sigma$.

If $[\mathbb{Z} \setminus B(0, r)]$ is bichromatic for large enough r , sort Σ in increasing order, for instance:

$$\Sigma = \{\dots, \sigma_{-1}, \sigma_0, \sigma_1, \dots\} = \{\sigma_n : n \in I\}.$$

Then $T_{[\Sigma]}$ sends $\bigsqcup_{n \in I} A_{k+n(\ell_+ - \ell_-)} \times \{\sigma_n\}$ to $\bigsqcup_{n \in I} A_{k+n(\ell_+ - \ell_-) + 1} \times \{\sigma_n\}$ for all $k \in \mathbb{Z}/M\mathbb{Z}$. In addition, transitions occur only from $A_{\ell_+ - 1} \times \{\sigma_n\}$ to $A_{\ell_+} \times \{\sigma_{n+1}\}$ or from $A_{\ell_- - 1} \times \{\sigma_n\}$ to $A_{\ell_-} \times \{\sigma_{n-1}\}$.

Proof. Let $([\mathbb{Z}^d], \tilde{\mu}, \tilde{T})$ be such an extension, and choose R as in Proposition 3.2. Let $\Sigma \subset \mathbb{Z}^d$ satisfying the conditions of Proposition 3.3.

First case: monochromatic extensions

We start with the first case. Since the extension is monochromatic away from $[0]$, let $\ell \in \mathbb{Z}/M\mathbb{Z}$ be its colour. Let $p \in \Sigma$ and $(x, p) \in [p]$.

If $T_{[\Sigma]}(x, p) \in [p]$, then $T_{[\Sigma]}(x, p) = (T_{[0]}(x), p)$. Given k such that $x \in A_k$, we get $T_{[0]}(x) \in A_{k+1}$, and thus $T_{[\Sigma]}(x, p) \in A_{k+1} \times \Sigma$.

Otherwise, let $q \in \Sigma$ be such that $T_{[\Sigma]}(x, p) \in [q]$. Then $T_{[\Sigma-q]}(x, p - q)$ is the first return to $[0]$ of the orbit of $(x, p - q)$ under \tilde{T} , and $(x, p - q) \in [\mathbb{Z}^d \setminus B(0, R)]$. Since the colour of the later is ℓ , this means that $T_{[\Sigma-q]}(x, p - q) \in A_\ell \times \{0\}$, and thus $T_{[\Sigma]}(x, p) \in A_\ell \times \{q\}$. In addition, using again the monochromaticity of $[\mathbb{Z}^d \setminus B(0, R)]$, the first return of $T_{[\Sigma]}(x, p)$ to $[p]$ belongs to $A_\ell \times \{p\}$. But, since this first return is $(T_{[0]}(x), p)$, this implies that $x \in A_{\ell-1}$.

Second case: bichromatic extensions

We now tackle the second case. By Proposition 3.2, the extension is a \mathbb{Z} -extension. It has colour ℓ_- on the large enough negatives and $\ell_+ \neq \ell_-$ on the large enough positives numbers. Let $p \in \Sigma$ and $(x, p) \in [p]$.

If there exists non-adjacent sites $p < q < r$ in Σ such that $\mu([p] \cap T_{[\Sigma]}^{-1}([r])) > 0$, then $p - q$ and $r - q$ have the same colour, so $\ell_+ = \ell_-$; the same holds if $\mu([r] \cap T_{[\Sigma]}^{-1}([q])) > 0$. This contradicts the bichromaticity of the extension. Hence the only allowed transitions are between adjacent sites in Σ .

Again, if $T_{[\Sigma]}(x, p) \in [p]$, then $T_{[\Sigma]}(x, p) = (T_{[0]}(x), p)$. Given k such that $x \in A_k$, we get $T_{[0]}(x) \in A_{k+1}$, and thus $T_{[\Sigma]}(x, p) \in A_{k+1} \times \Sigma$.

Otherwise, let $q \in \Sigma$ be such that $T_{[\Sigma]}(x, p) \in [q]$. Assume without loss of generality that $q > p$. Then the same arguments as in the first case yield $T_{[\Sigma]}(x, p) \in A_{\ell_-} \times \{q\}$ and $(x, p) \in A_{\ell_+-1} \times [p]$.

Let us sort the elements of Σ in increasing order, indexing them either by $I = \{0, \dots, |\Sigma| - 1\}$, $I = \mathbb{N}$ or $I = \mathbb{Z}$; this let us write, for instance, $\Sigma = \{\dots, \sigma_{-1}, \sigma_0, \sigma_1, \dots\}$. A transition from σ_n to σ_{n+1} starts from $A_{\ell_+-1} \times \{\sigma_n\}$ and ends in $A_{\ell_-} \times \{\sigma_{n+1}\}$, while a transition from σ_n to σ_{n-1} starts from $A_{\ell_- - 1} \times \{\sigma_n\}$ and ends in $A_{\ell_+} \times \{\sigma_{n-1}\}$. In particular, $T_{[\Sigma]}$ sends $\bigsqcup_{n \in I} A_{k+n(\ell_+-\ell_-)} \times \{\sigma_n\}$ to $\bigsqcup_{n \in I} A_{k+n(\ell_+-\ell_-)+1} \times \{\sigma_n\}$ for all $k \in \mathbb{Z}/M\mathbb{Z}$. □

Remark 3.4 (Examples of monochromatic and bichromatic extensions).

Constructing a monochromatic \mathbb{Z}^d -extension is easy. Choose a Gibbs-Markov map (A, α, d, μ, T) with a non-trivial period, and jump only at a given instant in the period. For instance, take

- $A = \mathbb{T} \times \mathbb{Z}/5\mathbb{Z}$,
- μ is proportional to the Lebesgue measure on A ,
- $T(x, k) = (3x, k + 1)$,
- $F(x, 0) = -1$ if $x \in [0, 1/3)$, then $F(x, 0) = +1$ if $x \in [2/3, 1)$ and $F(x, k) = 0$ otherwise.

Then $A_k = \mathbb{T} \times \{k\}$ and $\ell = 1$.

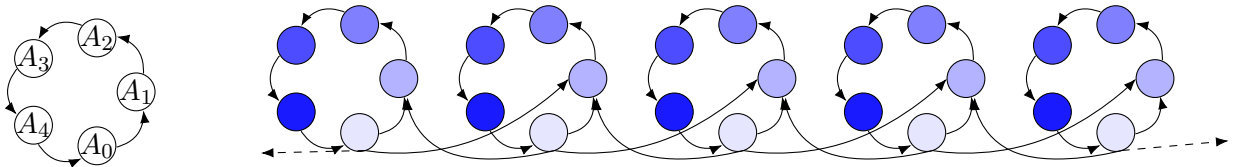

Figure 5: On the left: the allowed transitions for the transformation T and the five elements of the partition in periodic components $\{A_0, A_1, \dots, A_4\}$ of $T_{[0]}$. On the right: the \mathbb{Z} -extension of T and its allowed transitions. The five shades of blue correspond to the five elements of the partition $\{A_0 \times \mathbb{Z}, A_1 \times \mathbb{Z}, \dots, A_4 \times \mathbb{Z}\}$ of $[\mathbb{Z}]$. All allowed transitions lead to a subset one shade darker, or from the darkest shade to the lightest.

The analyses in the proofs of Propositions 3.2 and 3.3 give a guide to construct a bichromatic extension. We tweak the Gibbs-Markov map defined above. We still take $A = \mathbb{T} \times \mathbb{Z}/5\mathbb{Z}$ and μ proportional to the Lebesgue measure, but:

$$T(x, k) = \begin{cases} (2x, 3) & \text{if } x \in [0, 1/2) \text{ and } k = 0 \\ (2x, 1) & \text{if } x \in [0, 1/2) \text{ and } k = 2 \\ (2x, k + 1) & \text{otherwise} \end{cases} .$$

We choose for F :

$$F(x, k) = \begin{cases} +1 & \text{if } x \in [0, 1/2) \text{ and } k = 0 \\ -1 & \text{if } x \in [0, 1/2) \text{ and } k = 2 \\ 0 & \text{otherwise} \end{cases} .$$

Then $A_k = \mathbb{T} \times \{k\}$, $\ell_+ = 1$ and $\ell_- = 3$.

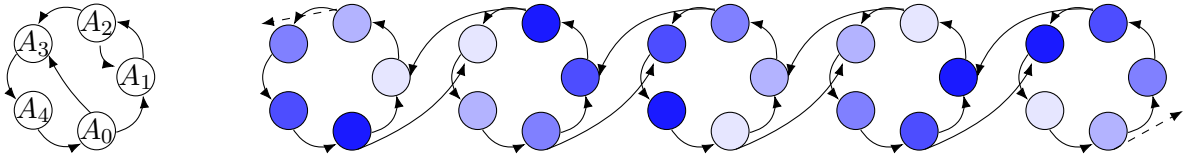

Figure 6: On the left: the allowed transitions for the transformation T and the five elements of the partition in periodic components $\{A_0, A_1, \dots, A_4\}$ of $T_{[0]}$. On the right: the \mathbb{Z} -extension of T and its allowed transitions. The five shades of blue correspond to the five elements of the partition $\{\bigsqcup_{n \in \mathbb{Z}} A_{k-2n} \times \{n\} : k \in \mathbb{Z}/5\mathbb{Z}\}$ of $[\mathbb{Z}]$. All allowed transitions lead to a subset one shade darker, or from the darkest shade to the lightest.

Remark 3.5 (Structure of bichromatic extensions).

As per Proposition 3.2, a bichromatic extension can occur only if $d = 1$ and $\|F\|_{\mathbb{L}^\infty(A, \mu)} < +\infty$. A reasonable conjecture is that such extensions can only occur if $d = 1$ and there exists a bounded coboundary $u \circ T - u$ such that $F + u \circ T - u$ takes its values in $\{-1, 0, 1\}$.

Remark 3.6 (Non Gibbs-Markov maps).

The structure of \mathbb{Z}^d -extensions when the induced map $(A, \mu, T_{[0]})$ has some periodicity may be different for maps which are not Gibbs-Markov. An interesting example is that of piecewise expanding maps of the interval with a compatible jump function. Then $(A, \mu, T_{[0]})$ is still a piecewise expanding map of the interval (with infinitely many pieces).

Up to additional conditions to check [34, 46], we may expect its transfer operator to act quasi-compactly on the space of functions with bounded variation, from which we can develop a similar description of its spectrum. In particular, if $(A, \mu, T_{[0]})$ is not mixing, then it has a decomposition in periodic components, from which we can construct a colouring of $[\mathbb{Z}^d]$. However, our argument in this article relies heavily on the big image property of Gibbs-Markov maps, which is not satisfied for general piecewise expanding maps of the interval. In this case, how are Propositions 3.2 and 3.3 to be adapted? Are $[\mathbb{Z}^d]$ -extensions of piecewise expanding maps either monochromatic or bichromatic?

3.2 End of the proof of Lemma 1.20

We now finish the proof of Lemma 1.20. We explain the main adaptations to make to the proof of Lemma 1.19, first in the case of monochromatic extensions, and then in the case of bichromatic extensions.

Proof of Lemma 1.20. Assume Hypotheses 1.2 and 1.10. Let $M \geq 1$ be the period of $([0], \mu, T_{[0]})$ and $(A_k)_{k \in \mathbb{Z}/M\mathbb{Z}}$ a decomposition of A in periodic components for $T_{[0]}$.

First case: monochromatic extensions

By Hypothesis 1.10, the probability of transition between different sites in $[\Sigma_\varepsilon]$ converges to 0. By recurrence and ergodicity, $\lim_{\varepsilon \rightarrow 0} \min_{p \neq q \in \Sigma_\varepsilon} \|p - q\| = +\infty$. We can thus apply Proposition 3.3: there exists $\ell \in \mathbb{Z}/M\mathbb{Z}$ such that, for all small enough $\varepsilon > 0$, the map T_ε sends each $A_k \times I$ into $A_{k+1} \times I$, and all transitions between distinct sites occur from $A_{\ell-1} \times I$ to $A_\ell \times I$. Hence, $T_\varepsilon^M(A_k \times I) = A_k \times I$ for all k .

Let us fix some $k \in \mathbb{Z}/M\mathbb{Z}$, and work with the measure-preserving dynamical system $(A_k \times I, M\mu_{I|A_k \times I}, T_\varepsilon^M)$. A suitable Banach space is given by the space $\mathcal{B}_{I,k}$ of functions in \mathcal{B}_I supported on $A_k \times I$ (recall that A_k is $\sigma(\alpha^*)$ -measurable, so multiplication by $\mathbf{1}_{A_k \times I}$ is continuous on \mathcal{B}_I). We define operators $\Pi_{k,*} : \mathcal{B}_{I,k} \rightarrow \mathbb{C}^I$ and $\Pi_k^* : \mathbb{C}^I \rightarrow \mathcal{B}_{I,k}$ in the same way as we defined Π_* and Π^* , that is respectively by averaging in each $A_k \times \{i\}$ and by finding the preimage that is constant on each $A_k \times \{i\}$. From there a definition of cones $C_{k,K}(\varepsilon)$ is straightforward.

The operator $\mathcal{L}_{[0]}$ acts quasi-compactly on \mathcal{B} , and thus so does $\mathcal{L}_{[0]}^M$. It follows that the action of $\mathcal{L}_{[0]}^M$ on the space \mathcal{B}_k of functions in \mathcal{B} supported on A_k is also quasi-compact. Since $(A_k, M\mu_{|A_k}, T_{[0]}^M)$ is mixing, the action $\mathcal{L}_{[0]}^M \curvearrowright \mathcal{B}_k$ has a spectral gap.

Let $i \neq j \in I$. Let ℓ' be to smallest integer larger than k and congruent to ℓ modulo M . A point $(x, i) \in A_k \times \{i\}$ belongs to $T_\varepsilon^{-M}(A_k \times \{j\})$ if and only if $T_{[0]}^{\ell' - k - 1}(x, i)$ belongs to $T_\varepsilon^{-1}([j])$, so that

$$\begin{aligned} M\mu_{|A_k}(x : (x, i) \in T_\varepsilon^{-M}(A_k \times \{j\})) &= M\mu \left(T_{[0]}^{1+k-\ell'}(\{x : (x, i) \in T_\varepsilon^{-1}([j])\}) \right) \\ &= M\mu([i] \cap T_\varepsilon^{-1}([j])) \\ &= \varepsilon MR_{ij} + o(\varepsilon). \end{aligned}$$

In addition, if $(x, i) \in A_k \times \{i\}$ and $T_\varepsilon^M(x, i) \in A_k \times \{i\}$, then $T_\varepsilon^n(x, i) \in A_k \times \{i\}$ for all $0 \leq n \leq M$, so that $T_\varepsilon^M(x, i) = T_{[0]}^M(x, i)$.

From there, the proof of Proposition 2.5 follows mostly unchanged, replacing \mathcal{L}_ε by $\mathcal{L}_\varepsilon^M$ and $C_K(\varepsilon)$ by $C_{k,K}(\varepsilon)$. More explicitly, for all $\sigma > 0$, there exist $K_\sigma, n_\sigma \geq 0$ such that, for all $K \geq K_\sigma$, for all $\varepsilon > 0$ and $n \geq n_\sigma$,

$$\mathcal{L}_\varepsilon^{Mn}(C_{k,K}(\varepsilon)) \subset C_{k,\sigma K}(\varepsilon).$$

Corollary 2.6 follows directly. Subsection 2.2 is unchanged as it makes no reference to the dynamics. Corollary 2.13 follows with only the obvious adaptations, and so does Proposition 2.14. We get a variant of Equation (2.12):

$$\lim_{\varepsilon \rightarrow 0} \sup_{t \in [0, T]} \left\| \Pi_{k,*} \mathcal{L}_\varepsilon^{M[\varepsilon^{-1}M^{-1}t]} f_\varepsilon - e^{-t(tR)} \Pi_{k,*} f_\varepsilon \right\|_{\ell^1(I)} = 0 \quad \forall (f_\varepsilon)_{\varepsilon > 0} \in C_{k,K}(\varepsilon).$$

The map $\mathcal{L}_{[0]}^n : \mathcal{B}_{k,I} \rightarrow \mathcal{B}_{k+n,I}$ is continuous with a norm of at most $\left\| \mathcal{L}_{[0]}^n \right\|_{\mathcal{B}_I \rightarrow \mathcal{B}_I}$, since we are only restricting $\mathcal{L}_{[0]}^n$ to functions supported on A_k . We can also apply Proposition 2.11 to get that

$$\Pi_{k+n,*} \mathcal{L}_\varepsilon^n f_\varepsilon = (1 + O(\varepsilon)) \Pi_{k,*} f_\varepsilon,$$

where $n = \lfloor \varepsilon^{-1}t \rfloor - M \lfloor \varepsilon^{-1}M^{-1}t \rfloor$ and the $O(\varepsilon)$ term depends only on the choice of K . This yields

$$\lim_{\varepsilon \rightarrow 0} \sup_{t \in [0, T]} \left\| \Pi_{k+\lfloor \varepsilon^{-1}t \rfloor, *} \mathcal{L}_\varepsilon^{\lfloor \varepsilon^{-1}t \rfloor} f_\varepsilon - e^{-t(tR)} \Pi_{k+\lfloor \varepsilon^{-1}t \rfloor, *} f_\varepsilon \right\|_{\ell^1(I)} = 0 \quad \forall (f_\varepsilon)_{\varepsilon > 0} \in C_{k,K}(\varepsilon).$$

Proposition 2.14 also carries over:

$$\|\mathcal{L}_\varepsilon^{Mn}\|_{(\mathcal{B}_{k,I,0},\|\cdot\|_{k,K,\varepsilon})\rightarrow(\mathcal{B}_{k,I,0},\|\cdot\|_{k,K,\varepsilon})} \leq Ce^{-\rho M\varepsilon n}$$

for some constants $C, \rho > 0$ (which can be taken arbitrarily close to ρ_R), all $n \geq 0$ and all small enough $\varepsilon > 0$. Again, using the boundedness of $\mathcal{L}_\varepsilon^n : \mathcal{B}_{k,I} \rightarrow \mathcal{B}_{k+n,I}$, up to increasing the constants C and K , we get

$$\|\mathcal{L}_\varepsilon^n\|_{(\mathcal{B}_{k,I,0},\|\cdot\|_{k,K,\varepsilon})\rightarrow(\mathcal{B}_{k+n,I,0},\|\cdot\|_{k+n,K,\varepsilon})} \leq Ce^{-\rho\varepsilon n}.$$

The statement of Corollary 2.17 can be adapted by replacing $\mathcal{B}_{I,0}$ by $\mathcal{B}_{k,I,0}$. However, we want in the end a statement for functions constant on each $[i] \in [I]$, so this is not satisfactory. Some caution is needed at this point; what we get is that, given $K \geq 0$ and a family on functions $(f_\varepsilon)_{\varepsilon>0} \in \bigoplus_{k \in \mathbb{Z}/M\mathbb{Z}} \mathcal{B}_{k,I,0}$ such that $\sup_{\varepsilon>0} \sup_{k \in \mathbb{Z}/M\mathbb{Z}} \|f_\varepsilon\|_{k,K,\varepsilon}$,

$$\sum_{n=0}^{+\infty} \mathcal{L}_\varepsilon^n f_\varepsilon = \frac{1}{\varepsilon} \Pi^*({}^t R_0^{-1}) \Pi_* f_\varepsilon + o(\varepsilon^{-1}),$$

where the equality holds in $\mathcal{B}_{I,0}$. The space $\bigoplus_{k \in \mathbb{Z}/M\mathbb{Z}} \mathcal{B}_{k,I,0}$ is of codimension $M - 1$ in $\mathcal{B}_{I,0}$: if we want the series $\sum_{n=0}^{+\infty} \mathcal{L}_\varepsilon^n f_\varepsilon$ to actually be summable, we need f_ε to have zero average on each $A_k \times I$, and not just on the whole of $[I]$. Under this slight modification, the proof of Corollary 2.17 can be adapted up to straightforward modifications, starting from

$$\sum_{n=0}^{+\infty} \mathcal{L}_\varepsilon^n f_\varepsilon = \sum_{k \in \mathbb{Z}/M\mathbb{Z}} \sum_{n=0}^{+\infty} \mathbf{1}_{A_{k+n} \times I} \mathcal{L}_\varepsilon^n (f_\varepsilon \mathbf{1}_{A_k \times I}),$$

and working with each k separately. Finally, given $f \in \mathbb{C}_0^I$, the function $\Pi^* f$ do belong to the space $\bigoplus_{k \in \mathbb{Z}/M\mathbb{Z}} \mathcal{B}_{k,I,0}$, which finishes the proof of Lemma 1.20 in the case of monochromatic extensions.

Second case: bichromatic extensions

As with monochromatic extensions, under Hypothesis 1.10, the minimal distance between sites in Σ_ε converges to $+\infty$, so that we can apply Proposition 3.3.

Let us index the sites in Σ_ε in increasing order by $I := \{0, \dots, |\Sigma_\varepsilon| - 1\}$. This reindexing conjugate both the matrices P_ε and Q_ε by the same permutation matrix, which depends on $\varepsilon > 0$. Since there are only finitely many permutation matrices, it is enough to prove the theorem on the subsequences of $\varepsilon > 0$ corresponding to any fixed permutation. Hence, up to restriction to suitable subsequences, we assume simultaneously that Hypothesis 1.10 holds and that the indexing of Σ_ε is increasing.

By Proposition 3.3, there exist $\ell_- \neq \ell_+ \in \mathbb{Z}/M\mathbb{Z}$ such that all transitions for T_ε occur from $A_{\ell_+-1} \times \{n\}$ to $A_{\ell_-} \times \{n+1\}$ or from $A_{\ell_- - 1} \times \{n\}$ to $A_{\ell_+} \times \{n-1\}$. We set $\tilde{A}_k := \bigsqcup_{n \in I} A_{k+n(\ell_+ - \ell_-)} \times \{n\}$ so that T_ε^M preserves all the subsets \tilde{A}_k for all small enough ε .

The adaptation is then mostly the same as in the monochromatic case, replacing $A_k \times I$ by \tilde{A}_k . There are two significant differences. The first is that jumps upwards and jumps downwards happen at different times, so the argument which in the monochromatic case yielded

$$M\mu|_{A_k}(x : (x, i) \in T_\varepsilon^{-M}(A_k \times \{j\})) = \varepsilon MR_{ij} + o(\varepsilon)$$

does not work immediately. Here is how this argument can be fixed. First, note that, from times $k = 0$ to $k = M$, a trajectory cannot get up then down, or down then up. Indeed, a trajectory of the

first kind would have to go through $A_{\ell_+-1} \times \{n\}$, then $A_{\ell_-} \times \{n+1\}$, then $A_{\ell_--1} \times \{n+1\}$, then $A_{\ell_+} \times \{n\}$, which requires at least $M+1$ steps. The same reasoning applies to trajectories of the second kind.

Let $k \in \mathbb{Z}/M\mathbb{Z}$. Let ℓ'_- (respectively ℓ'_+) be the least integer strictly larger than k and congruent to ℓ_- (respectively ℓ_+) modulo M . Assume without loss of generality that $\ell'_- < \ell'_+$. Then

$$\begin{aligned} M\mu_{|A_k}(x : (x, n) \in T_\varepsilon^{-M}(\{0, \dots, n-1\})) &= M\mu(x : (x, n) \in T_\varepsilon^{-1}([n-1])) \\ &= \varepsilon MR_{n, n-1} + o(\varepsilon), \end{aligned}$$

with the same argument as in the monochromatic case. In addition,

$$\begin{aligned} M\mu_{|A_k}(x : (x, n) \in T_\varepsilon^{-M}(\{n+1, \dots, |I\})) &= M\mu_{|A_k}(x : (x, n) \in T_\varepsilon^{-M}(\{n+1, \dots, |I\}) \text{ and } (x, n) \notin T_\varepsilon^{-M}(\{0, \dots, n-1\})) \\ &= M \int_{A_{\ell_+-1}} \mathbf{1}_{\{x:(x,n) \in T_\varepsilon^{-1}([n+1])\}} \mathcal{L}_{[0]}^{\ell_+ - \ell_-} \left(\mathbf{1} - \mathbf{1}_{\{x:(x,n) \in T_\varepsilon^{-1}([n-1])\}} \right) d\mu \\ &= M\mu(x : (x, n) \in T_\varepsilon^{-1}([n-1])) \\ &\quad - M \int_{A_{\ell_+-1}} \mathbf{1}_{\{x:(x,n) \in T_\varepsilon^{-1}([n+1])\}} \mathcal{L}_{[0]}^{\ell_+ - \ell_-} \left(\mathbf{1}_{\{x:(x,n) \in T_\varepsilon^{-1}([n-1])\}} \right) d\mu. \end{aligned}$$

By Corollary A.7,

$$\left\| \mathcal{L}_{[0]}^{\ell_+ - \ell_-} \left(\mathbf{1}_{\{x:(x,n) \in T_\varepsilon^{-1}([n-1])\}} \right) \right\|_{\mathcal{B}} \leq C\mu(x : (x, n) \in T_\varepsilon^{-1}([n-1])) = O(\varepsilon),$$

so that

$$\begin{aligned} M\mu_{|A_k}(x : (x, n) \in T_\varepsilon^{-M}(\{n+1, \dots, |I\})) &= M(1 + O(\varepsilon))\mu(x : (x, n) \in T_\varepsilon^{-1}([n+1])) \\ &= \varepsilon MR_{n, n+1} + o(\varepsilon). \end{aligned}$$

Finally, the same reasoning let us show that the measure of points which undergo at least two jumps before time M is in $O(\varepsilon^2)$, so that

$$\begin{aligned} M\mu_{|A_k}(x : (x, n) \in T_\varepsilon^{-M}([n-1])) &= M\mu_{|A_k}(x : (x, n) \in T_\varepsilon^{-M}(\{0, \dots, n-1\})) + O(\varepsilon^2) \\ &= \varepsilon MR_{n, n-1} + o(\varepsilon), \end{aligned}$$

and the same for $M\mu_{|A_k}(x : (x, n) \in T_\varepsilon^{-M}([n+1]))$.

The second difference is that, when adapting Proposition 2.5, we work with the action of $\mathcal{L}_{[0]}^M$ on $\mathcal{B}_{k+n(\ell_+-\ell_-)}$, which depends on the site n . In the end, this does not matter: as k takes only finitely many values, there are finitely many such actions, so that all relevant controls are uniform in n . \square

4 From potential to transition probabilities

We now finish the proof of Theorem 0.1.

In Sections 2 (under the mixing Hypothesis 1.18) and 3, knowing an asymptotic development $P_\varepsilon = \text{Id} - \varepsilon R + o(\varepsilon)$, we were able to deduce an asymptotic development $Q_\varepsilon = \varepsilon^{-1} R_0^{-1} + o(\varepsilon^{-1})$.

However, in practice, we can compute Q_ε and want to estimate P_ε . Since the direct direction comes from Lemma 1.20, we shall work under Hypothesis 1.12:

$$Q_\varepsilon = \varepsilon^{-1}S + o(\varepsilon^{-1}),$$

where S is irreducible in the sense of Definition 1.13.

In order to deduce the asymptotics of P_ε from those of Q_ε , we shall consider an adherence point R of $\varepsilon^{-1}(\text{Id} - P_\varepsilon)$. Then, an application of Lemma 1.19 yields that $R_0 = S^{-1}$, and thus Theorem 0.1. The two main obstructions are:

- the existence of an adherence point of $\varepsilon^{-1}(\text{Id} - P_\varepsilon)$. We shall prove that $\varepsilon^{-1}(\text{Id} - P_\varepsilon)$ stays bounded when ε vanishes. This is the object of Subsection 4.1.
- in order to apply Lemma 1.19, the matrix R needs to be irreducible. This is the object of Subsection 4.2.

Our main tool is that Lemma 1.19 implies Theorem 0.1 whenever we induce on two sites, i.e. whenever $|I| = 2$. This let us transfer precious information from Q_ε to P_ε .

4.1 Bootstrapping

We start our analysis with the case $|I| = 2$, which can be deduced directly from Section 2. The general case will follow.

If $|I| = 2$, then \mathbb{C}_0^I is 1-dimensional, so Q_ε is a scalar, which we shall denote by q_ε . The matrix P_ε is bi-stochastic, and thus can be written as

$$P_\varepsilon = \begin{pmatrix} 1 - p_\varepsilon & p_\varepsilon \\ p_\varepsilon & 1 - p_\varepsilon \end{pmatrix} = \text{Id} - p_\varepsilon \begin{pmatrix} 1 & -1 \\ -1 & 1 \end{pmatrix} =: \text{Id} - p_\varepsilon R \quad (4.1)$$

for some constant $p_\varepsilon > 0$.

Lemma 4.1.

Assume Hypotheses 1.2, 1.18 and 1.12. Assume furthermore that the matrix S from Hypothesis 1.12 is irreducible in the sense of Definition 1.13. Assume finally that $|I| = 2$, so that $S = s$ is a scalar. Then

$$p_\varepsilon \sim_{\varepsilon \rightarrow 0} \frac{\varepsilon}{2s}.$$

Proof. In the $|I| = 2$ case, Hypothesis 1.12 reads $q_\varepsilon \sim_{\varepsilon \rightarrow 0} \varepsilon^{-1}s$. The irreducibility of S in the sense of Definition 1.13 is equivalent to the property that $s > 0$.

As a consequence, $\lim_{\varepsilon \rightarrow 0} q_\varepsilon = +\infty$. This is only possible if the distance between the two sites of Σ_ε grows to $+\infty$ when ε vanishes. By [40, Lemma 4.17], we have $\lim_{\varepsilon \rightarrow 0} p_\varepsilon = 0$: indeed, if the two sites are very far away one from the other, then the probability of transitioning from one to the other gets very small.

The matrix R in equation (4.1) is irreducible. Hence, by Lemma 1.19,

$$q_\varepsilon \sim_{\varepsilon \rightarrow 0} \frac{1}{p_\varepsilon} R_0^{-1}.$$

But $R(f) = 2f$ for all $f \in \mathbb{C}_0^I$, or in other words $R_0 = 2\text{Id}$, so

$$q_\varepsilon \sim_{\varepsilon \rightarrow 0} \frac{1}{2p_\varepsilon} \sim_{\varepsilon \rightarrow 0} \frac{1}{\varepsilon},$$

from which the claim follows. □

Remark 4.2.

The $|I| = 2$ case was one of the main results of [40], where it was proved using an argument on the distributional asymptotics of the Birkhoff sums for \tilde{T} of $\mathbf{1}_{[\sigma_\varepsilon(i)]} - \mathbf{1}_{[\sigma_\varepsilon(j)]}$. Lemma 4.1 is already a more general variant of [40, Corollary 2.9].

In addition, much of the proof of Lemma 1.19 can be simplified in the case $|I| = 2$, since we can replace matrices by scalars, giving a more streamlined proof of Lemma 4.1. More generic tools, for instance from [29], may be applicable.

The boundedness of the family $\varepsilon^{-1}(\text{Id} - P_\varepsilon)$ in the general case readily follows.

Lemma 4.3.

Assume Hypotheses 1.2, 1.18 and 1.12. Assume furthermore that the matrix S from Hypothesis 1.12 is irreducible in the sense of Definition 1.13.

Then $\text{Id} - P_\varepsilon = O(\varepsilon)$.

Proof. Let $i \neq j \in I$. Let $\widehat{\Sigma}_\varepsilon := \{\sigma_\varepsilon(i), \sigma_\varepsilon(j)\} \subset \Sigma_\varepsilon$. The potential operator \widehat{Q}_ε associated with the induced map on $\widehat{\Sigma}_\varepsilon$ can be recovered from Q_ε in the following way:

- Take a function $f \in \mathbb{C}_0^{\{i,j\}}$. Extend f to a function $f\mathbf{1}_{\{i,j\}} \in \mathbb{C}_0^I$ by setting $f\mathbf{1}_{\{i,j\}}(k) := 0$ for $k \notin \{i, j\}$.
- Apply Q_ε to $f\mathbf{1}_{\{i,j\}}$ to get a function $g \in \mathbb{C}_0^I$.
- Restrict g to $\{i, j\}$, to get a function $g|_{\{i,j\}} \in \mathbb{C}^{\{i,j\}}$.
- Add a constant to $g|_{\{i,j\}}$ to get the function $\widehat{Q}_\varepsilon f \in \mathbb{C}_0^{\{i,j\}}$.

The family $(\widehat{Q}_\varepsilon)_{\varepsilon>0}$ thus has the asymptotics

$$\widehat{Q}_\varepsilon = \varepsilon^{-1}\widehat{S} + o(\varepsilon^{-1}),$$

where \widehat{S} is the restriction of S to $\mathbb{C}_0^{\{i,j\}}$ composed with the projection onto $\mathbb{C}_0^{\{i,j\}}$ parallel to constants. Since $(\mathbf{1}_i - \mathbf{1}_j)$ is supported on $\{i, j\}$ and has zero sum,

$$\langle (\mathbf{1}_i - \mathbf{1}_j), \widehat{S}(\mathbf{1}_i - \mathbf{1}_j) \rangle_{\ell^2(I)} = \langle (\mathbf{1}_i - \mathbf{1}_j), S(\mathbf{1}_i - \mathbf{1}_j) \rangle_{\ell^2(I)} > 0,$$

so that \widehat{S} is also irreducible in the sense of Definition 1.13. By Lemma 4.1,

$$\mu \left(\left(\tilde{T}^n(x, \sigma_\varepsilon(i)) \right)_{n \geq 1} \text{ reaches } [\sigma_\varepsilon(j)] \text{ before going back to } [\sigma_\varepsilon(i)] \right) \sim_{\varepsilon \rightarrow 0} \frac{\varepsilon}{\langle (\mathbf{1}_i - \mathbf{1}_j), \widehat{S}(\mathbf{1}_i - \mathbf{1}_j) \rangle_{\ell^2(I)}}. \quad (4.2)$$

But the left hand-side is larger than or equal to $(P_\varepsilon)_{ij}$, so that all the off-diagonal terms of P_ε are in $O(\varepsilon)$. \square

4.2 Irreducibility of the bi-L-matrix

We now end the proof of Theorem 0.1 when there are more than two sites. Up to extraction of a subsequence, we may assume that $\text{Id} - P_\varepsilon = \varepsilon R + o(\varepsilon)$. The matrix R is a bi-L-matrix. We want to show that $R_0^{-1} = S$. This is a consequence of Lemma 1.19 if R is irreducible. Our next focus is to prove that R is indeed irreducible.

Lemma 4.4.

Assume Hypotheses 1.2, 1.18 and 1.12. Assume furthermore that the matrix S from Hypothesis 1.12 is irreducible in the sense of Definition 1.13.

Let R be an adherence point of $(\varepsilon^{-1}(\text{Id} - P_\varepsilon))_{\varepsilon > 0}$. Then R is an irreducible bi-L-matrix.

Proof. Let R be such an adherence point. Since P_ε is bi-stochastic by Lemma 1.4 and the space of bi-L-matrices is closed, R is a bi-L-matrix.

By Equation (4.2), under these hypotheses, for any two distinct $i, j \in I$,

$$\mu \left(\left(\tilde{T}^n(x, \sigma_\varepsilon(i)) \right)_{n \geq 1} \text{ reaches } [\sigma_\varepsilon(j)] \text{ before going back to } [\sigma_\varepsilon(i)] \right) = \Theta(\varepsilon).$$

Inducing on $[\Sigma_\varepsilon]$ yields

$$\mu \left(\left(T_\varepsilon^n(x, i) \right)_{n \geq 1} \text{ reaches } [j] \text{ before going back to } [i] \right) = \Theta(\varepsilon).$$

We proceed by contradiction: if R is reducible, we prove that there exist i and j such that the above probability is an $o(\varepsilon)$.

Let \sim_R be the relation on I generated by $i \sim_R j$ if $R_{ij} < 0$ and $i \sim_R i$. The relation \sim_R is reflexive and transitive. Since the counting measure is in the kernel of R , there are no absorbing subsets of I , so the relation \sim_R is also symmetric.

Assume that R is not irreducible. Let I_1 be an equivalence class for \sim_R . Let $i \in I_1$ and $j \in I \setminus I_1$. By definition of \sim_R , we have $P_{\varepsilon, k\ell} = o(\varepsilon)$ for all $k \in I_1$ and $\ell \in I \setminus I_1$. Setting

$$B_{\varepsilon,1} = \{(x, k) \in [I_1] : T_\varepsilon(x, k) \in [I \setminus I_1]\},$$

the set of points in $[I_1]$ which exit $[I_1]$ under T_ε , we get $\mu_{I_1}(B_{\varepsilon,1}) = o(\varepsilon)$.

We want to estimate the probability, starting from $[i]$, to hit $[j]$ before going back to $[i]$. Let $T_{\varepsilon,1} : [I_1] \rightarrow [I_1]$ be the map obtained by inducing T_ε on $[I_1]$. Let

$$\varphi_{[i]}^{T_{\varepsilon,1}}(x) := \inf\{n \geq 1 : T_{\varepsilon,1}^n(x, i) \in [I]\}.$$

Note that

$$\left\{ \left(T_\varepsilon^n(x, i) \right)_{n \geq 1} \text{ reaches } [j] \text{ before going back to } [i] \right\} \subset \left\{ \exists 0 \leq n < \varphi_{[i]}^{T_{\varepsilon,1}}(x) : T_{\varepsilon,1}^n(x, i) \in B_{\varepsilon,1} \right\},$$

whence, using Kac's formula,

$$\begin{aligned} \mu \left(\left(T_\varepsilon^n(x, i) \right)_{n \geq 1} \text{ reaches } [j] \text{ before going back to } [i] \right) &\leq \mu \left(\exists 0 \leq n < \varphi_{[i]}^{T_{\varepsilon,1}}(x) : T_{\varepsilon,1}^n(x, i) \in B_{\varepsilon,1} \right) \\ &= \int_A \max_{0 \leq n < \varphi_{[i]}^{T_{\varepsilon,1}}(x)} \mathbf{1}_{B_{\varepsilon,1}} \circ T_{\varepsilon,1}^n(x, i) \, d\mu(x) \\ &\leq \int_A \sum_{0 \leq n < \varphi_{[i]}^{T_{\varepsilon,1}}(x)} \mathbf{1}_{B_{\varepsilon,1}} \circ T_{\varepsilon,1}^n(x, i) \, d\mu(x) \\ &= |I_1| \mu_{I_1}(B_{\varepsilon,1}) \\ &= o(\varepsilon). \end{aligned}$$

This gives the contradiction we want. Hence, our additional assumption is false: R is indeed irreducible. \square

Let us wrap up to proof of Theorem 0.1.

Proof of Theorem 0.1. The direct implication is the content of Lemma 1.19; we prove the converse direction. Assume Hypotheses 1.2 and 1.12. Assume furthermore that the matrix S from Hypothesis 1.12 is irreducible in the sense of Definition 1.13.

By Lemma 4.3, the family $(\varepsilon^{-1}(\text{Id} - P_\varepsilon))_{\varepsilon > 0}$ is bounded. Let R be one of its adherence points. By Lemma 4.4, R is an irreducible bi-L-matrix.

Let $(\varepsilon_k)_{k \geq 0}$ be converging to 0 such that $P_{\varepsilon_k} = \text{Id} - \varepsilon_k R + o(\varepsilon_k)$. Since R is a bi-L-matrix, it is null on constant functions and preserves \mathbb{C}_0^I . By Lemma 1.19, we have $S = R_0^{-1}$, whence $R_0 = S^{-1}$. This characterizes the action of R on \mathbb{C}_0^I . Hence the matrix R is entirely characterized by S , and thus the adherence point of $(\varepsilon^{-1}(\text{Id} - P_\varepsilon))_{\varepsilon > 0}$ is unique. This proves that $P_\varepsilon = \text{Id} - \varepsilon R + o(\varepsilon)$, and finishes the proof of Theorem 0.1. \square

5 Fourier transform and perturbations of the transfer operator

Let (A, μ, T) be an ergodic Gibbs-Markov map with transfer operator \mathcal{L} acting on \mathcal{B} . Let $F : A \rightarrow \mathbb{Z}^d$ be Markov, and assume that the \mathbb{Z}^d -extension $([\mathbb{Z}^d], \tilde{\mu}, \tilde{T})$ is ergodic. Let $(\Sigma_\varepsilon)_{\varepsilon > 0}$ be a family of subsets of \mathbb{Z}^d . Theorem 0.1 relates the transition matrices $(P_\varepsilon)_{\varepsilon > 0}$ to the potential operators $(Q_\varepsilon)_{\varepsilon > 0}$.

Our goal is to compute, in a few cases, the asymptotics of the operators $(Q_\varepsilon)_{\varepsilon > 0}$, and in particular the operator S appearing in Hypothesis 1.12; from there we shall deduce, at least in some cases, the asymptotics of the transition matrices $(P_\varepsilon)_{\varepsilon > 0}$. First, we shall develop general tools involving perturbations of transfer operators.

In order to circumvent some summability issues which may arise in the computation of

$$(\text{Id} - \tilde{\mathcal{L}})^{-1} = \sum_{n \geq 0} \tilde{\mathcal{L}}^n,$$

we shall approximate this operator by

$$(\text{Id} - \rho \tilde{\mathcal{L}})^{-1} = \sum_{n \geq 0} \rho^n \tilde{\mathcal{L}}^n$$

with $|\rho| < 1$, and then take the limit as $\rho \rightarrow 1$. However, this requires working with a twisted Poisson equation and complicates significantly the relationship between $\tilde{\mathcal{L}}$ and \mathcal{L}_ε . This will be the object of Subsection 5.1, where we shall prove the following:

Proposition 5.1.

Let $([\mathbb{Z}^d], \tilde{\mu}, \tilde{T})$ be an ergodic and recurrent Markov \mathbb{Z}^d -extension of a Gibbs-Markov map. Let I be non-empty and finite and $\sigma : I \hookrightarrow \mathbb{Z}^d$ with image Σ .

Let $Q_\sigma : \mathbb{C}_0^I \rightarrow \mathbb{C}_0^I$ be defined, as in Equation (1.9), by :

$$\langle f, Q_\sigma(g) \rangle_{\ell^2(I)} := |I| \int_{[\mathbb{Z}^d]} (\text{Id} - \mathcal{L}_{[\Sigma]})^{-1} \left(\sum_{i \in I} f_i \mathbf{1}_{[\sigma(i)]} \right) \cdot \left(\sum_{j \in I} g_j \mathbf{1}_{[\sigma(j)]} \right) d\mu_{[\Sigma]}.$$

Then:

$$\langle f, Q_\sigma(g) \rangle_{\ell^2(I)} = \lim_{\rho \rightarrow 1^-} \sum_{n \geq 0} \rho^n \sum_{i, j \in I} f_i g_j \mu(S_n F = \sigma(j) - \sigma(i)).$$

For random walks, the computation of $Q_\varepsilon = Q_{\sigma_\varepsilon}$ involves taking the Fourier transform of the distribution of F , or in other words, uses the characteristic function of F . As mentioned in Sub-section 1.5.4, in a dynamical context, the role of this characteristic function is taken by the main eigenvalue of twisted transfer operators. We recall that these operators are defined, for $w \in \mathbb{T}^d := \mathbb{R}_{2\pi\mathbb{Z}^d}^d$, by

$$\mathcal{L}_w(\cdot) = \mathcal{L}(e^{i\langle w, F \rangle} \cdot), \quad (5.1)$$

which acts on $\mathbb{L}^p(A, \mu)$ for all $p \in [1, \infty]$, as well as on \mathcal{B} .

In addition, we also define a Fourier transform for functions defined on I , transporting them first to Σ before taking their Fourier transform on \mathbb{Z}^d :

Definition 5.2 (Fourier transform operator).

Let $d \geq 1$, I be finite and $\sigma : I \hookrightarrow \mathbb{Z}^d$ an injective map. We define for all $f \in \mathbb{C}^I$:

$$\mathcal{F}_\sigma(f)(w) := \sum_{j \in I} f_j e^{-i\langle w, \sigma(j) \rangle} \quad \forall w \in \mathbb{T}^d \quad (5.2)$$

the Fourier transform of the function taking value f_j on $\sigma(j)$ and 0 everywhere else. We also set $\check{\mathcal{F}}_\sigma(f)(w) := \mathcal{F}_\sigma(f)(-w)$.

Given a family $\sigma_\varepsilon : I \hookrightarrow \mathbb{Z}^d$ of injective maps, we denote by $\mathcal{F}_\varepsilon = \mathcal{F}_{\sigma_\varepsilon}$ the corresponding Fourier transform operators.

We want to understand the behaviour of $\sum_{n \geq 0} \tilde{\mathcal{L}}^n$ using Fourier transform, which implies understanding the behaviour of \mathcal{L}_w for all $w \in \mathbb{T}^d$. This will be done in two steps. In Subsection 5.2, we explore the eigenvalues of modulus 1 of \mathcal{L}_w in order to ensure that $(\text{Id} - \rho \mathcal{L}_w)^{-1}$ is well-defined. Then, in Subsection 5.3, we apply this study together with Proposition 5.1 to get the proposition mentioned in Sub-section 1.5.4:

Proposition 5.3.

Let $([\mathbb{Z}^d], \tilde{\mu}, \tilde{T})$ be an ergodic and recurrent Markov \mathbb{Z}^d -extension of a Gibbs-Markov map. Let I be non-empty and finite and $\sigma : I \hookrightarrow \mathbb{Z}^d$ with image Σ . Then, for all $f, g \in \mathbb{C}_0^I$:

$$\langle f, Q_\sigma(g) \rangle_{\ell^2(I)} = \lim_{\rho \rightarrow 1^-} \frac{1}{(2\pi)^d} \int_{\mathbb{T}^d} \check{\mathcal{F}}_\sigma(f) \mathcal{F}_\sigma(g) \left(\int_A (\text{Id} - \rho \mathcal{L}_w)^{-1}(\mathbf{1}) \, d\mu \right) \, dw. \quad (5.3)$$

In particular, let U be a small enough neighbourhood of $0 \in \mathbb{T}^d$. Let λ_w be the main eigenvalue of \mathcal{L}_w such that $\lambda_0 = 1$, which is well-defined and continuous on U . Then:

$$\langle f, Q_\sigma(g) \rangle_{\ell^2(I)} = \lim_{\rho \rightarrow 1^-} \frac{1}{(2\pi)^d} \int_U \check{\mathcal{F}}_\sigma(f) \mathcal{F}_\sigma(g) \frac{1 + \delta_w}{1 - \rho \lambda_w} \, dw + O_U(1) \|f\| \cdot \|g\|, \quad (5.4)$$

where $w \mapsto \delta_w$ is continuous on a neighbourhood of $0 \in \mathbb{T}^d$ with $\delta_0 = 0$, and the error term $O_U(1)$ is uniform in ρ and σ but depends on U .

Conjecture 5.4.

If $|1 - \lambda_w| \geq c \|w\|^2$ for some $c > 0$, or even $|1 - \lambda_w| \geq c \|w\|^{3-\iota}$ for some $c, \iota > 0$, then Equation (5.4) can be simplified, using the fact that $\check{\mathcal{F}}_\sigma(f)$ and $\mathcal{F}_\sigma(g)$ are both $O(\|w\|)$ near 0:

$$\lim_{\rho \rightarrow 1^-} \frac{1}{(2\pi)^d} \int_U \check{\mathcal{F}}_\sigma(f) \mathcal{F}_\sigma(g) \frac{1 + \delta_{\rho, w}}{1 - \rho \lambda_w} \, dw = \frac{1}{(2\pi)^d} \int_U \check{\mathcal{F}}_\sigma(f) \mathcal{F}_\sigma(g) \frac{1 + \delta_w}{1 - \lambda_w} \, dw.$$

The condition $|1 - \lambda_w| \geq c \|w\|^2$ is true for ergodic random walks, and all examples in Section 6. A general argument still eludes the author.

Equation (5.4) is exactly what we need to compute the asymptotics of $(Q_\varepsilon)_{\varepsilon>0}$ from the asymptotics of the main eigenvalue of the twisted transfer operators \mathcal{L}_w . Applications will be given in Section 6, where we shall explore a few examples with more constraints on the family $(\Sigma_\varepsilon)_{\varepsilon>0}$ and the jump function F : extensions with square-integrable jumps in dimensions 1 and 2, as well as extensions with jumps in the basin of attraction of a Lévy stable distribution in dimension $d = 1$.

5.1 Twisted Poisson equations

Our first goal is to prove Proposition 5.1. Let $([\mathbb{Z}^d], \tilde{\mu}, \tilde{T})$ be an ergodic and recurrent Markov \mathbb{Z}^d -extension of a Gibbs-Markov map. Let I be non-empty and finite and $\sigma : I \hookrightarrow \mathbb{Z}^d$ with image Σ .

Definition 5.5.

For all $\rho \in B(0, 1)$, let $Q_{\sigma, \rho} : \mathbb{C}_0^I \rightarrow \mathbb{C}_0^I$ be the operator such that, for all $f, g \in \mathbb{C}_0^I$,

$$\langle f, Q_{\sigma, \rho}(g) \rangle_{\ell^2(I)} := \int_{[\mathbb{Z}^d]} \sum_{n=0}^{+\infty} \rho^n \tilde{\mathcal{L}}^n \left(\sum_{i \in I} f_i \mathbf{1}_{[\sigma(i)]} \right) \cdot \left(\sum_{j \in I} g_j \mathbf{1}_{[\sigma(j)]} \right) d\tilde{\mu}.$$

Note that the sum is well-defined since $\rho \tilde{\mathcal{L}}$ is a strict contraction on $\mathbb{L}^1([\mathbb{Z}^d], \tilde{\mu})$. We define $Q_{\sigma, 1}$ as in Equation (1.9), replacing Σ_ε by Σ .

Note that, for all $n \geq 0$,

$$\begin{aligned} \int_{[\mathbb{Z}^d]} \tilde{\mathcal{L}}^n \left(\sum_{i \in I} f_i \mathbf{1}_{[\sigma(i)]} \right) \cdot \left(\sum_{j \in I} g_j \mathbf{1}_{[\sigma(j)]} \right) d\tilde{\mu} &= \int_{[\mathbb{Z}^d]} \left(\sum_{i \in I} f_i \mathbf{1}_{[\sigma(i)]} \right) \cdot \left(\sum_{j \in I} g_j \mathbf{1}_{[\sigma(j)]} \right) \circ \tilde{T}^n d\tilde{\mu} \\ &= \sum_{i, j \in I} f_i g_j \int_{[\sigma(i)]} \mathbf{1}_{[\sigma(j)]} \circ \tilde{T}^n d\mu \\ &= \sum_{i, j \in I} f_i g_j \mu(S_n F = \sigma(j) - \sigma(i)), \end{aligned}$$

so we need to prove that $\lim_{\rho \rightarrow 1} Q_{\sigma, \rho} = Q_{\sigma, 1}$.

Note that $[I]$ is endowed with a partition α_Σ generated by $\varphi_{[\Sigma]}$. More precisely, elements of α_Σ in $[i] \subset [I]$ are elements of the partition $\alpha_{i, \Sigma}$ generated by the stopping time

$$\varphi_{i, [\Sigma]} := \inf\{n \geq 1 : \sigma(i) + S_n F \in \Sigma\}.$$

That said, we will need the following

Lemma 5.6.

Let $([\mathbb{Z}^d], \tilde{\mu}, \tilde{T})$ be an ergodic and recurrent Markov \mathbb{Z}^d -extension of a Gibbs-Markov map. Let I be non-empty and finite and $\sigma : I \hookrightarrow \mathbb{Z}^d$ with image Σ .

Let $\varphi : [I] \rightarrow \mathbb{R}_+$ a nonnegative function constant on the elements of the partition α_Σ of $[I]$. Then:

- the family of operators $(\mathcal{L}_k)_{k \geq 0}$ acting on \mathcal{B}_I and defined by $\mathcal{L}_k(f) := \mathcal{L}_{[\Sigma]}(e^{-k\varphi} f)$ is continuous in the operator topology.

- for k small enough, there exists a continuous family of eigenvalues λ_k of \mathcal{L}_k such that $\lambda_0 = 1$.
- setting $H(k) := \int_{[I]} (1 - e^{-k\varphi}) d\mu_I$, we have $(1 - \lambda_k) \sim_{k \rightarrow 0} H(k)$.
- $\|\mathcal{L} - \mathcal{L}_k\|_{\mathcal{B}_I \rightarrow \mathcal{B}_I} = O(H(k))$.

Proof. We start by proving a strengthened version of the last point. We introduce the auxiliary semi-norm:

$$|f|_{\text{Lip}^1([I])} := \sum_{p \in \Sigma} \sum_{a \in \alpha_{p, \Sigma}} \mu(a) |f(\cdot, p)|_{\text{Lip}(a)},$$

and the auxiliary norm $\|f\|_{\text{Lip}^1([I])} := \|f\|_{\mathbb{L}^1([I], \mu_I)} + |f|_{\text{Lip}^1([I])}$.

Let $k, k' \geq 0$ and $f \in \mathcal{B}_I$. Then

$$\begin{aligned} \left\| e^{-k\varphi} f - e^{-k'\varphi} f \right\|_{\mathbb{L}^1([I], \mu_I)} &\leq \left\| e^{-\min\{k, k'\}\varphi} \right\|_{\mathbb{L}^\infty([I], \mu_I)} \left\| 1 - e^{-|k-k'|\varphi} \right\|_{\mathbb{L}^1([I], \mu_I)} \|f\|_{\mathbb{L}^\infty([I], \mu_I)} \\ &\leq H(|k - k'|) \|f\|_{\mathbb{L}^\infty([I], \mu_I)}. \end{aligned}$$

In addition, seeing φ as a function from α_Σ to \mathbb{R}_+ ,

$$\begin{aligned} \left| e^{-k\varphi} f - e^{-k'\varphi} f \right|_{\text{Lip}^1([I])} &= \sum_{a \in \alpha_\Sigma} \mu_I(a) \left| (e^{-k\varphi} - e^{-k'\varphi}) f \right|_{\text{Lip}(a)} \\ &= \sum_{a \in \alpha_\Sigma} \mu_I(a) \left| e^{-k\varphi(a)} - e^{-k'\varphi(a)} \right| \cdot |f|_{\text{Lip}(a)} \\ &\leq \left(\sum_{a \in \alpha_\Sigma} \mu_I(a) \left| 1 - e^{-|k-k'|\varphi(a)} \right| \right) \sup_{a \in \alpha_\Sigma} |f|_{\text{Lip}(a)} \\ &\leq H(|k - k'|) \max_{i \in I} \sup_{a \in \alpha^*} |f(\cdot, i)|_{\text{Lip}(a)}, \end{aligned}$$

where we used in the last step that α^* is coarser than $\alpha_{i, \Sigma}$ for all $i \in I$. Writing $(e^{-k\varphi} \cdot)$ the operator of multiplication by $e^{-k\varphi}$, these two computations together yield

$$\left\| (e^{-k\varphi} \cdot) - (e^{-k'\varphi} \cdot) \right\|_{\mathcal{B}_I \rightarrow \text{Lip}^1([I])} \leq H(|k - k'|).$$

By Proposition A.11, the operator $\mathcal{L}_{[\Sigma]} : \text{Lip}^1([I]) \rightarrow \mathcal{B}_I$ is bounded. Composition of the multiplication operators and $\mathcal{L}_{[\Sigma]}$ gives

$$\|\mathcal{L}_k - \mathcal{L}_{k'}\|_{\mathcal{B}_I \rightarrow \mathcal{B}_I} = O(H(|k - k'|)),$$

finishing the proof of the fourth point.

By the dominated convergence theorem, $\lim_{0+} H = 0$, finishing the proof of the first point.

Since $([\mathbb{Z}^d], \tilde{\mu}, \tilde{T})$ is ergodic, so is $([I], \mu_I, T_\Sigma)$, so 1 is an isolated eigenvalue of multiplicity 1 of $\mathcal{L}_{[\Sigma]}$. The second point follows from [28, Part IV.3.5].

All is left to prove is the third point. Let $(h_k)_{k \geq 0}$ be the family of eigenfunctions of $(\mathcal{L}_k)_{k \geq 0}$ corresponding to the eigenvalue λ_k and such that $\mu_I(h_k) = 1$, for all small enough k . Then $(h_k)_{k \geq 0}$

is continuous and $h_0 = \mathbf{1}$. Furthermore,

$$\begin{aligned} 1 - \lambda_k &= \int_{[I]} (\mathcal{L}_{[\Sigma]} - \mathcal{L}_k) h_k \, d\mu_I \\ &= \int_{[I]} (1 - e^{-k\varphi}) h_k \, d\mu_I \\ &= H(k) + \int_{[I]} (1 - e^{-k\varphi})(h_k - \mathbf{1}) \, d\mu_I. \end{aligned}$$

Again using [28, Part IV.3.5], $\|\mathbf{1} - h_k\|_{\mathcal{B}_I} = O\left(\|\mathcal{L}_{[\Sigma]} - \mathcal{L}_k\|_{\mathcal{B}_I \rightarrow \mathcal{B}_I}\right) = O(H(k))$, so that

$$\begin{aligned} \left| \int_{[I]} (1 - e^{-k\varphi})(h_k - \mathbf{1}) \, d\mu_I \right| &\leq \|1 - e^{-k\varphi}\|_{\mathbb{L}^1([I], \mu_I)} \|\mathbf{1} - h_k\|_{\mathbb{L}^\infty([I], \mu_I)} \\ &\leq H(k) \|\mathbf{1} - h_k\|_{\mathcal{B}_I} \\ &= O(H(k)^2), \end{aligned}$$

whence $(1 - \lambda_k) \sim_{k \rightarrow 0} H(k)$. □

We now proceed to the proof of Proposition 5.1.

Proof of Proposition 5.1. By [41, Lemma 1.7], for all $\rho \in (0, 1)$ and $f, g \in \mathbb{C}_0^I$,

$$\frac{1}{|I|} \int_{[\Sigma]} (\text{Id} - \rho \tilde{\mathcal{L}})^{-1} \left(\sum_{i \in I} f_i \mathbf{1}_{[\sigma(i)]} \right) \cdot \left(\sum_{j \in I} g_j \mathbf{1}_{[\sigma(j)]} \right) \, d\tilde{\mu} = \int_{[I]} (\text{Id} - \mathcal{L}_I(e^{\ln(\rho)\varphi_{[\Sigma]}}))^{-1} \Pi^*(f) \cdot \Pi^*(g) \, d\mu_I$$

where the operator $(\text{Id} - \rho \tilde{\mathcal{L}})^{-1}$ is defined on $\mathbb{L}^\infty([\mathbb{Z}^d], \tilde{\mu})$ and the operator $(\text{Id} - \mathcal{L}_I(e^{\ln(\rho)\varphi_{[\Sigma]}}))^{-1}$ on $\mathbb{L}^\infty([I], \mu_I)$.

We set $k := -\ln(\rho) \geq 0$. Let $\mathcal{L}_k := \mathcal{L}_I(e^{-k\varphi_{[\Sigma]}})$. By Lemma 5.6, there exists an eigendecomposition of \mathcal{L}_k , continuous in k , such that

$$\mathcal{L}_k = \lambda_k h_k \otimes \mu_{I,k} + Z_k,$$

with $\mu_{I,k}(h_k) = \mu_I(h_k) = 1$ for all k and Z_k the restriction of \mathcal{L}_k to $\text{Ker}(\mu_k) \subset \mathcal{B}_I$. Note that Z_k converges to the restriction of \mathcal{L}_I to $\mathcal{B}_{I,0}$, and h_k to $\mathbf{1}$ as well as $\mu_{I,k}$ to μ_I .

We then get for $f, g \in \mathbb{C}_0^I$,

$$\begin{aligned} \lim_{\rho \rightarrow 1^-} \langle f, Q_{\sigma, \rho}(g) \rangle_{\ell^2(I)} &= \lim_{k \rightarrow 0^+} |I| \int_{[I]} (\text{Id} - \mathcal{L}_k)^{-1} \Pi^*(f) \cdot \Pi^*(g) \, d\mu_I \\ &= \lim_{k \rightarrow 0^+} \left(|I| \int_{[I]} (\text{Id} - Z_k)^{-1} (\Pi^*(f) - \mu_{I,k}(\Pi^*(f)) h_k) \cdot \Pi^*(g) \, d\mu_I \right. \\ &\quad \left. + |I| \int_{[I]} \frac{\Pi^*(g) h_k \mu_{I,k}(\Pi^*(f))}{1 - \lambda_k} \, d\mu_I \right). \end{aligned}$$

On the one hand, since $\Pi^*(f) \in \mathcal{B}_{I,0}$,

$$\begin{aligned} \lim_{k \rightarrow 0^+} |I| \int_{[I]} (\text{Id} - Z_k)^{-1} (\Pi^*(f) - \mu_{I,k}(\Pi^*(f)) h_k) \cdot \Pi^*(g) \, d\mu_I \\ = \lim_{k \rightarrow 0^+} |I| \int_{[I]} (\text{Id} - Z_k)^{-1} (\Pi^*(f)) \cdot \Pi^*(g) \, d\mu_I \\ = |I| \int_{[I]} (\text{Id} - \mathcal{L}_{[\Sigma]})^{-1} \Pi^*(f) \cdot \Pi^*(g) \, d\mu_I \\ = \langle f, Q_\sigma(g) \rangle_{\ell^2(I)}. \end{aligned}$$

On the other hand, $\|\mathbf{1} - h_k\|_{\mathcal{B}_I} = O(H(k))$, as well as $\mu_{I,k}(\Pi^*(g)) = O(H(k))$ and $(1 - \lambda_k) \sim_{k \rightarrow 0^+} H(k)$, where $H(k) = \int_{[I]} (1 - e^{-k\varphi_{[\Sigma]}}) \, d\mu_I$. Hence

$$\begin{aligned} |I| \int_{[I]} \frac{\Pi^*(g) h_k \mu_{I,k}(\Pi^*(f))}{1 - \lambda_k} \, d\mu_I &= \int_{[I]} \Pi^*(g) h_k \, d\mu_I \cdot O(1) \\ &= \left(\int_{[I]} \Pi^*(g) \, d\mu_I + O(H(k)) \right) O(1) \\ &= O(H(k)). \end{aligned}$$

The claim follows from the fact that $\lim_{0^+} H = 0$. □

5.2 Transfer operators and periodicities

After taking a Fourier transform, we will have to work with the inverse of twisted transfer operators $(\text{Id} - \mathcal{L}_w)^{-1}$. We need to find the values of w such that $1 \in \text{Sp}(\mathcal{L}_w \curvearrowright \mathcal{B})$ in order to control these inverse operators. This leads us to a refinement of the spectral analysis done in [40], in particular [40, Proposition 3.2], so that we can remove the assumption of aperiodicity present in that article.

The action of \mathcal{L} on \mathcal{B} is quasi-compact: it admits 1 as a simple eigenvalue, has spectral radius 1 and essential spectral radius $\Lambda^{-1} < 1$, where Λ is the expansivity constant of the Gibbs-Markov map. The essential spectral radius of the operators \mathcal{L}_w is also bounded by Λ^{-1} , as they satisfy a Lasota-Yorke inequality with the same constants.

Lemma 5.7.

Let $([\mathbb{Z}^d], \tilde{\mu}, \tilde{T})$ be a Markov \mathbb{Z}^d -extension of a Gibbs-Markov map (A, α, d, μ, T) with jump function F . Assume that $([\mathbb{Z}^d], \tilde{\mu}, \tilde{T})$ is ergodic.

Let $M := |\{\lambda \in \text{Sp}(\mathcal{L} \curvearrowright \mathcal{B}) : |\lambda| = 1\}|$. Then there exist an integer $n \geq 1$ and an element $w_0 \in \mathbb{T}^d$ of primitive order n such that

$$H := \{(w, \lambda) \in \mathbb{T}^d \times \mathbb{S}^1 : \lambda \in \text{Sp}(\mathcal{L}_w \curvearrowright \mathcal{B})\} = \left\{ \left(kw_0, e^{2\pi i \frac{k}{Mn}} \right) : k \in \mathbb{Z}/Mn\mathbb{Z} \right\}.$$

In addition, each of these eigenvalues is simple.

Proof. The argument of [52, Lemma 3.1] can be adapted to prove that H is a subgroup of $\mathbb{T}^d \times \mathbb{S}^1$. The map T is not invertible. However, if h is a non-zero function such that $\mathcal{L}_w(h) = \lambda h$ for some $(w, \lambda) \in H$, then, by the equality case of the triangular inequality, h is constant on almost every

subset $T^{-1}(x)$ for $x \in A$, so that the computations in the proof of [52, Lemma 3.1] stay valid. In addition, each of these eigenvalues is simple.

Let $w \in \mathbb{T}^d$ be such that $1 \in \text{Sp}(\mathcal{L}_w \curvearrowright \mathcal{B})$. Let $h_{w,1}$ be an eigenfunction for this eigenvalue. Then $\mathcal{L}(e^{i\langle w, F \rangle} h_{w,1}) = h_{w,1}$. Define $f(x, p) := e^{-i\langle w, p \rangle} h_{w,1}(x)$ on $[\mathbb{Z}^d]$. As we check, f is invariant under the transfer operator $\tilde{\mathcal{L}}$:

$$\begin{aligned} \tilde{\mathcal{L}}(f)(x, p) &= \sum_{(y, q) \in \tilde{T}^{-1}(\{(x, p)\})} \frac{f(y, q)}{|\text{Jac}(T)(y)|} \\ &= \sum_{y \in T^{-1}(\{x\})} \frac{f(y, p - F(y))}{|\text{Jac}(T)(y)|} \\ &= e^{-i\langle w, p \rangle} \sum_{y \in T^{-1}(\{x\})} \frac{e^{i\langle w, F(y) \rangle} h_{w,1}(y)}{|\text{Jac}(T)(y)|} \\ &= e^{-i\langle w, p \rangle} \mathcal{L}_w(h_{w,1})(x) \\ &= e^{-i\langle w, p \rangle} h_{w,1}(x) \\ &= f(x, p). \end{aligned}$$

Since $([\mathbb{Z}^d], \tilde{\mu}, \tilde{T})$ is ergodic, f is constant, and in particular the map $p \mapsto e^{-i\langle w, p \rangle}$ is constant. Hence $w = 0$ in \mathbb{T}^d . In other words, the canonical projection $H \rightarrow \mathbb{S}^1$ is injective. Hence H is isomorphic to a subgroup of \mathbb{S}_1 , and thus cyclic.

Let \mathbb{U}_M be the group of peripheral eigenvalues of \mathcal{L} . Then $\{0\} \times \mathbb{U}_M$ is a subgroup of H , so M divides $|H|$. Setting $n := |H|/M$, there exists $w_0 \in \mathbb{T}^d$ such that

$$H = \left\{ \left(kw_0, e^{2\pi i \frac{k}{Mn}} \right) : k \in \mathbb{Z}/Mn\mathbb{Z} \right\}.$$

Taking $k = n$, we get that $(nw_0, e^{2\pi i \frac{1}{M}}) \in H$. But its image under the second projection is $e^{2\pi i \frac{1}{M}} \in \text{Sp}(\mathcal{L} \curvearrowright \mathcal{B})$, so by injectivity of the second projection, $nw_0 = 0$. In addition, $kw_0 \neq 0$ for $0 < k < n$; otherwise, we would get an eigenvalue of \mathcal{L} not in \mathbb{U}_M . \square

Lemma 5.7 let us control the operators $(\text{Id} - \mathcal{L}_w)^{-1}$.

Corollary 5.8.

Let $([\mathbb{Z}^d], \tilde{\mu}, \tilde{T})$ be a Markov \mathbb{Z}^d -extension of a Gibbs-Markov map (A, α, d, μ, T) with jump function F . Assume that $([\mathbb{Z}^d], \tilde{\mu}, \tilde{T})$ is ergodic.

Then, for any neighbourhood U of $0 \in \mathbb{T}^d$,

$$\sup_{w \in \mathbb{T}^d \setminus U} \|(\text{Id} - \mathcal{L}_w)^{-1}\|_{\mathcal{B} \rightarrow \mathcal{B}} < +\infty. \tag{5.5}$$

Proof. For $w \neq 0$, the spectrum of \mathcal{L}_w does not contain 1 by Lemma 5.7, so that $(\text{Id} - \mathcal{L}_w)$ is invertible. By the discussion following the proof of [21, Corollary 4.1.3], the family of operators $(\mathcal{L}_w)_{w \in \mathbb{T}^d}$ is continuous, so the family of operators $((\text{Id} - \mathcal{L}_w)^{-1})_{w \in \mathbb{T}^d \setminus \{0\}}$ is also continuous. The result follows by relative compactness of $\mathbb{T}^d \setminus U$ in $\mathbb{T}^d \setminus \{0\}$. \square

5.3 Fourier transform and twisted transfer operators

As announced, we now prove Proposition 5.3.

Proof of Proposition 5.3. Let $([\mathbb{Z}^d], \tilde{\mu}, \tilde{T})$ be an ergodic and recurrent Markov \mathbb{Z}^d -extension of a Gibbs-Markov map. Let I be non-empty and finite and $\sigma : I \hookrightarrow \mathbb{Z}^d$ with image Σ .

Let $f, g \in \mathbb{C}_0^I$. By Proposition 5.1,

$$\langle f, Q_\sigma(g) \rangle_{\ell^2(I)} = \lim_{\rho \rightarrow 1^-} \sum_{n \geq 0} \rho^n \sum_{i, j \in I} f_i g_j \mu(S_n F = \sigma(j) - \sigma(i)).$$

Let $n \geq 0$ and $i, j \in I$. Using the Fourier transform,

$$\begin{aligned} \mu(S_n F = \sigma(j) - \sigma(i)) &= \int_A \mathbf{1}_0(S_n F + \sigma(i) - \sigma(j)) \, d\mu \\ &= \int_A \frac{1}{(2\pi)^d} \int_{\mathbb{T}^d} e^{i\langle w, S_n F + \sigma(i) - \sigma(j) \rangle} \, dw \, d\mu \\ &= \frac{1}{(2\pi)^d} \int_{\mathbb{T}^d} e^{i\langle w, \sigma(i) - \sigma(j) \rangle} \int_A e^{i\langle w, S_n F \rangle} \, d\mu \, dw \\ &= \frac{1}{(2\pi)^d} \int_{\mathbb{T}^d} e^{i\langle w, \sigma(i) - \sigma(j) \rangle} \int_A \mathcal{L}_w^n(\mathbf{1}) \, d\mu \, dw. \end{aligned}$$

Summing over $i, j \in I$ yields

$$\begin{aligned} &\sum_{i, j \in I} f_i g_j \mu(S_n F = \sigma(j) - \sigma(i)) \\ &= \frac{1}{(2\pi)^d} \int_{\mathbb{T}^d} \left(\sum_{i \in I} f_i e^{i\langle w, \sigma(i) \rangle} \right) \left(\sum_{j \in I} g_j e^{-i\langle w, \sigma(j) \rangle} \right) \left(\int_A \mathcal{L}_w^n(\mathbf{1}) \, d\mu \right) \, dw \\ &= \frac{1}{(2\pi)^d} \int_{\mathbb{T}^d} \check{\mathcal{F}}_\sigma(f) \mathcal{F}_\sigma(g) \left(\int_A \mathcal{L}_w^n(\mathbf{1}) \, d\mu \right) \, dw, \end{aligned}$$

whence, weighting by ρ^n and summing over n ,

$$\begin{aligned} \langle f, Q_\sigma(g) \rangle_{\ell^2(I)} &= \lim_{\rho \rightarrow 1^-} \sum_{n \geq 0} \rho^n \frac{1}{(2\pi)^d} \int_{\mathbb{T}^d} \check{\mathcal{F}}_\sigma(f) \mathcal{F}_\sigma(g) \left(\int_A \mathcal{L}_w^n(\mathbf{1}) \, d\mu \right) \, dw, \\ &= \lim_{\rho \rightarrow 1^-} \frac{1}{(2\pi)^d} \int_{\mathbb{T}^d} \check{\mathcal{F}}_\sigma(f) \mathcal{F}_\sigma(g) \left(\int_A (\text{Id} - \rho \mathcal{L}_w)^{-1}(\mathbf{1}) \, d\mu \right) \, dw. \end{aligned}$$

This proves Equation (5.3).

Since $w \mapsto \mathcal{L}_w$ is continuous and 1 is an isolated eigenvalue of \mathcal{L} , for any small enough neighbourhood U of $0 \in \mathbb{T}^d$, there exists a continuous eigendecomposition:

$$\mathcal{L}_w = \lambda_w h_w \otimes \mu_w + Z_w,$$

with $\mu_w(h_w) = \mu(h_w) = 1$ for all $w \in -U$, as well as $\lambda_0 = 1$. In addition, up to taking a smaller neighbourhood U , the operators $((\text{Id} - \rho Z_w)^{-1})_{\rho \geq 0, w \in U}$ are uniformly bounded by continuity. Then,

$$\begin{aligned} \int_A (\text{Id} - \rho \mathcal{L}_w)^{-1}(\mathbf{1}) \, d\mu &= \int_A \frac{\mu_w(\mathbf{1}) h_w}{1 - \rho \lambda_w} \, d\mu + \int_A (\text{Id} - \rho Z_w)^{-1}(\mathbf{1} - \mu_w(\mathbf{1}) h_w) \, d\mu \\ &= \frac{\mu_w(\mathbf{1})}{1 - \rho \lambda_w} + O(1). \end{aligned}$$

In addition, the family of operators $((\text{Id} - \mathcal{L}_w)^{-1})_{w \in \mathbb{T}^d \setminus U}$ is bounded by Corollary 5.8. By continuity, the family of operators $((\text{Id} - \rho \mathcal{L}_w)^{-1})_{\rho \geq 0, w \in \mathbb{T}^d \setminus U}$ is also bounded, and

$$\sup_{\rho \geq 0, w \in \mathbb{T}^d \setminus U} \left| \int_A (\text{Id} - \rho \mathcal{L}_w)^{-1}(\mathbf{1}) \, d\mu \right| < +\infty.$$

Putting everything together, we get

$$\langle f, Q_\sigma(g) \rangle_{\ell^2(I)} = \lim_{\rho \rightarrow 1^-} \frac{1}{(2\pi)^d} \int_{\mathbb{T}^d} \check{\mathcal{F}}_\sigma(f) \mathcal{F}_\sigma(g) \frac{\mu_w(\mathbf{1})}{1 - \rho \lambda_w} \, dw + O_U(1) \|f\| \cdot \|g\|.$$

Setting $\delta_w := \mu_w(\mathbf{1}) - 1$, which converges to 0 when w vanishes, yields Proposition 5.3. \square

6 Computation of the potential operators

With the groundwork done in Section 5, we are ready to compute the asymptotics of the transition matrices in a few important cases. We shall consider sets $(\Sigma_\varepsilon)_{\varepsilon > 0}$ with a limiting shape as introduced in Subsection 1.4.1. We shall also add classical assumptions on the tails of the distribution the jump F , for instance square-integrability or being in the basin of attraction of a Lévy stable distribution.

In this section, we assume that $([\mathbb{Z}^d], \tilde{\mu}, \tilde{T})$ is an ergodic and recurrent Markov \mathbb{Z}^d -extension of a Gibbs-Markov map (A, μ, T) with jump function $F : A \rightarrow \mathbb{Z}^d$.

Let I be non-empty and finite and $\sigma : I \hookrightarrow \mathbb{R}^d$. We choose $(\sigma_t)_{t > 0} : I \hookrightarrow \mathbb{Z}^d$ such that, for all $i \in I$,

$$\sigma_t(i) = t\sigma(i) + o(t),$$

as in Figure 2. This point of view, where t is of the same order as the distance between sites of Σ_t , seems more intuitive, and shall be used to write the propositions. Letting $\varepsilon := t^{-1}$, the asymptotics $t \rightarrow +\infty$ correspond to asymptotic $\varepsilon \rightarrow 0$ as in the previous parts of this work, and the variable ε shall be used in lieu of t in the demonstrations.

Once this setting is fixed, most computations rely on the same strategies as [40, Subsection 3.5]. An important difference is that we compute a matrix S such that $Q_\varepsilon \sim a(\varepsilon)S$ for some function $a(\varepsilon)$, and then invert S , while [40] only involved the computation of scalars. This adds a layer of linear algebra, which we solve in a few cases, but not in full generality. As a consequence, we split this section in four cases:

- square-integrable jump functions in dimension 1 (Subsection 6.1);
- jump functions in the basin of attraction of a Lévy stable distribution with parameter in $(1, 2)$ in dimension 1 (Subsection 6.2), for which the author was not able to invert S in full generality;
- some jump functions in the basin of attraction of a Cauchy distribution (Subsection 6.3);
- square-integrable jump functions in dimension 2 (Subsection 6.4), with a behaviour *in fine* similar to the Cauchy case but quite different computations.

There are a few specialized cases which we do not write down, although they may be of some practical interest. In particular, we leave to the interested reader the situation where F has tails with regular variation of index 2, and thus lies in the basin in attraction of a Gaussian, while not being square-integrable. This specific situation can occur as a toy model for Lorentz gases in infinite horizon, for which the diffusion channels give rise to supercritical diffusion [8, 49].

6.1 Computation of the potential: $d = 1$, square integrable jumps

In addition to the general setting of Section 6, we assume in this Subsection that F is square-integrable and centered, the later condition being already implied by the first condition and the ergodicity of the extension.

Let Var be the asymptotic variance F :

$$\text{Var} := \int_A F^2 d\mu + 2 \sum_{n \geq 1} \int_A F \circ T^n \cdot F d\mu, \quad (6.1)$$

where the infinite series is taken in the sense of Cesàro. Since $([\mathbb{Z}], \tilde{\mu}, \tilde{T})$ is ergodic, F is not a coboundary and thus Var is positive [21, Théorème 4.1.4].

We shall now get our first application of Theorem 0.1:

Proposition 6.1.

Let $([\mathbb{Z}], \tilde{\mu}, \tilde{T})$ be an ergodic and recurrent Markov \mathbb{Z} -extension of a Gibbs-Markov map (A, μ, T) with jump function $F : A \rightarrow \mathbb{Z}$. Assume furthermore that $F \in \mathbb{L}^2(A, \mu)$. Let $\text{Var} > 0$ be that asymptotic variance of F defined by Equation (6.1).

Let $I = \{1, \dots, |I|\}$ and $\sigma : I \hookrightarrow \mathbb{R}$ be injective and increasing. For $t > 0$, let $\sigma_t : I \hookrightarrow \mathbb{Z}$ be such that $\sigma_t(i) = t\sigma(i) + o(t)$ for all $i \in I$. Let P_t be the transition matrix of the Markov chain induced on $\Sigma_t := \sigma_t(I)$. Then

$$P_t =_{t \rightarrow +\infty} \text{Id} - \frac{\text{Var}}{t} R + o(t^{-1}),$$

where R is the irreducible, tridiagonal, symmetric bi-L-matrix defined by

$$\begin{cases} R_{i,i+1} = -\frac{1}{2(\sigma(i+1) - \sigma(i))} & \forall 1 \leq i < |I|, \\ R_{i,i-1} = -\frac{1}{2(\sigma(i) - \sigma(i-1))} & \forall 1 < i \leq |I|, \\ R_{ij} = 0 & \text{whenever } |i - j| \geq 2, \\ R_{ii} = \sum_{j \in I, j \neq i} |R_{ij}| & \forall i \in I. \end{cases} \quad (6.2)$$

Under the hypotheses of Proposition 6.1, and setting $\Delta_i^j := |\sigma(j) - \sigma(i)|$, the transition matrices $(P_t)_{t > 0}$ have the following graphical representation:

$$P_t = \begin{pmatrix} 1 - \frac{2\text{Var}}{t\Delta_1^2} & \frac{2\text{Var}}{t\Delta_1^2} & 0 & \dots & 0 & 0 \\ \frac{2\text{Var}}{t\Delta_1^2} & 1 - \frac{2\text{Var}}{t\Delta_1^2} - \frac{2\text{Var}}{t\Delta_2^3} & \frac{2\text{Var}}{t\Delta_2^3} & \dots & 0 & 0 \\ 0 & \frac{2\text{Var}}{t\Delta_2^3} & 1 - \frac{2\text{Var}}{t\Delta_2^3} - \frac{2\text{Var}}{t\Delta_3^4} & \dots & 0 & 0 \\ \vdots & \ddots & \ddots & \ddots & \vdots & \vdots \\ 0 & 0 & 0 & \dots & 1 - \frac{2\text{Var}}{t\Delta_{|I|-2}^{|I|}} - \frac{2\text{Var}}{t\Delta_{|I|-1}^{|I|}} & \frac{2\text{Var}}{t\Delta_{|I|-1}^{|I|}} \\ 0 & 0 & 0 & \dots & \frac{2\text{Var}}{t\Delta_{|I|-1}^{|I|}} & 1 - \frac{2\text{Var}}{t\Delta_{|I|-1}^{|I|}} \end{pmatrix} + o(t^{-1}).$$

Proof. We assume the setting of Proposition 6.1. By [21, Théorème 4.1.4], the main eigenvalue of \mathcal{L}_w admits the expansion

$$\lambda_w = 1 - \frac{\text{Var} w^2}{2} + o(w^2). \quad (6.3)$$

We set $\varepsilon := t^{-1}$. By Proposition 5.3, for any small enough neighbourhood U of $0 \in \mathbb{T}$, for all $\varepsilon > 0$, for all $f, g \in \mathbb{C}_0^I$,

$$\begin{aligned} \langle f, Q_\varepsilon(g) \rangle_{\ell^2(I)} &= \lim_{\rho \rightarrow 1^-} \frac{1}{2\pi} \int_{\mathbb{T}} \check{\mathcal{F}}_\varepsilon(f) \mathcal{F}_\varepsilon(g) \int_A (\text{Id} - \rho \mathcal{L}_w)^{-1}(\mathbf{1}) \, d\mu \, dw \\ &= \frac{1}{2\pi} \int_U \check{\mathcal{F}}_\varepsilon(f) \mathcal{F}_\varepsilon(g) \frac{1 + \delta_w}{1 - \lambda_w} \, dw + O_U(1) \|f\| \|g\|. \end{aligned}$$

Note that $\check{\mathcal{F}}_\varepsilon(f)(w)$ and $\mathcal{F}_\varepsilon(g)(w)$ are both in $O(|w|)$ while the denominator is in $\Theta(w^2)$ by Equation (6.3), so the integrand is bounded for each $\varepsilon > 0$. This justifies that we took the limit in Equation (5.4).

Let us set

$$1 + \delta'_w := (1 + \delta_w) \frac{\text{Var } w^2}{2(1 - \lambda_w)},$$

so that δ'_w is also a continuous function of w with $\lim_{w \rightarrow 0} \delta'_w = 0$. In addition, we choose $U = (-\eta, \eta)$ for small enough $\eta > 0$. Then:

$$\langle f, Q_\varepsilon(g) \rangle_{\ell^2(I)} = \frac{1}{\pi \text{Var}} \int_{-\eta}^{\eta} \check{\mathcal{F}}_\varepsilon(f) \mathcal{F}_\varepsilon(g) \frac{1 + \delta'_w}{w^2} \, dw + O_\eta(1) \|f\| \|g\|. \quad (6.4)$$

We split this integral in three parts:

- the integral involving the error term δ'_w on a small neighbourhood $(-\varepsilon, \varepsilon)$ of 0, which shall be negligible because both δ'_w and the term $\left(\check{\mathcal{F}}_\varepsilon(f) \mathcal{F}_\varepsilon(g) \right)(w)$ are small near 0.
- the integral involving the error term δ'_w on $(-\eta, \eta) \setminus (-\varepsilon, \varepsilon)$, which shall be negligible because δ'_w is small and w^2 is large.
- the integral without the error term δ'_w , which is the main contribution to $\langle f, Q_\varepsilon(g) \rangle_{\ell^2(I)}$.

Control of δ'_w on the neighbourhood $(-\varepsilon, \varepsilon)$.

To control the part of the integral (6.4) involving δ'_w on $(-\varepsilon, \varepsilon)$, remark that, since both f and g have zero sum, $\check{\mathcal{F}}_\varepsilon(f)$ and $\mathcal{F}_\varepsilon(g)$ are in $O(w)$ for all $\varepsilon > 0$. More precisely,

$$\begin{aligned} \check{\mathcal{F}}_\varepsilon(f)(w) &= \sum_{i \in I} f_i e^{iw\sigma_\varepsilon(i)} \\ &= \sum_{i \in I} f_i \left(e^{iw(\varepsilon^{-1}\sigma(i) + o(\varepsilon^{-1}))} - 1 \right) \\ &= O(\varepsilon^{-1}|w| \|f\|), \end{aligned} \quad (6.5)$$

and likewise for $\mathcal{F}_\varepsilon(g)$. Hence

$$\begin{aligned} \int_{-\varepsilon}^{\varepsilon} \check{\mathcal{F}}_\varepsilon(f) \mathcal{F}_\varepsilon(g) \frac{\delta'_w}{w^2} \, dw &= \int_{(-\varepsilon, \varepsilon)} O(\varepsilon^{-2} w^2 \|f\| \|g\|) \frac{\max_{w \in [-\eta, \eta]} |\delta'_w|}{w^2} \, dw \\ &= O\left(\varepsilon^{-1} \|f\| \|g\| \max_{w \in [-\eta, \eta]} |\delta'_w|\right). \end{aligned}$$

Control of the error term δ'_w on $(-\eta, \eta) \setminus (-\varepsilon, \varepsilon)$.

On $(-\eta, \eta) \setminus (-\varepsilon, \varepsilon)$, we get

$$\begin{aligned}
& \left| \int_{(-\eta, \eta) \setminus (-\varepsilon, \varepsilon)} \check{\mathcal{F}}_\varepsilon(f) \mathcal{F}_\varepsilon(g) \frac{\delta'_w}{w^2} dw \right| \\
& \leq C \int_{(-\eta, \eta) \setminus (-\varepsilon, \varepsilon)} \frac{\max_{w \in [-\eta, \eta]} |\delta'_w|}{w^2} dw \cdot \|f\| \|g\| \\
& \leq C \varepsilon^{-1} \max_{w \in [-\eta, \eta]} |\delta'_w| \int_{\mathbb{R} \setminus (-1, 1)} \frac{1}{w^2} dw \cdot \|f\| \|g\| \\
& = O(\varepsilon^{-1} \|f\| \|g\| \max_{w \in [-\eta, \eta]} |\delta'_w|).
\end{aligned}$$

Main contribution to the integral (6.4).

Now let us focus on the remaining term. Let us split $\check{\mathcal{F}}_\varepsilon(f) \mathcal{F}_\varepsilon(g)$ along its frequencies:

$$\begin{aligned}
\left(\check{\mathcal{F}}_\varepsilon(f) \mathcal{F}_\varepsilon(g) \right) (w) &= \left(\sum_{i \in I} f_i e^{iw\sigma_\varepsilon(i)} \right) \left(\sum_{j \in I} g_j e^{-iw\sigma_\varepsilon(j)} \right) \\
&= \sum_{i, j \in I} f_i g_j e^{iw(\sigma_\varepsilon(i) - \sigma_\varepsilon(j))} \\
&= \sum_{i, j \in I} f_i g_j (e^{iw(\sigma_\varepsilon(i) - \sigma_\varepsilon(j))} - 1).
\end{aligned}$$

Injecting this expression into the main part of Equation (6.4) yields

$$\begin{aligned}
& \frac{1}{\pi \text{Var}} \int_{-\eta}^{\eta} \frac{\check{\mathcal{F}}_\varepsilon(f) \mathcal{F}_\varepsilon(g)}{w^2} dw \\
&= \frac{2}{\pi \text{Var}} \int_0^\eta \sum_{i, j \in I} f_i g_j \frac{\cos(w(\sigma_\varepsilon(i) - \sigma_\varepsilon(j))) - 1}{w^2} dw \\
&= \frac{2}{\pi \text{Var}} \sum_{i, j \in I} f_i g_j \int_0^\eta \frac{\cos(\varepsilon^{-1}w(\sigma(i) - \sigma(j) + o(1))) - 1}{w^2} dw \\
&= \frac{2}{\varepsilon \pi \text{Var}} \sum_{i, j \in I} f_i g_j (\sigma(i) - \sigma(j) + o(1)) \int_0^{\varepsilon^{-1}(\sigma(i) - \sigma(j) + o(1))\eta} \frac{\cos(w) - 1}{w^2} dw \\
&=_{\varepsilon \rightarrow 0} -\frac{1}{\varepsilon \text{Var}} \sum_{i, j \in I} f_i g_j |\sigma(i) - \sigma(j)| + o(\varepsilon^{-1}),
\end{aligned}$$

were the last line comes from the well-known integral [18, Chap. XVII.4, 4.11]

$$\int_0^{+\infty} \frac{\cos(w) - 1}{w^2} dw = -\frac{\pi}{2}.$$

Asymptotics of the potential Q_ε .

Adding the terms involving δ'_w to the main contribution yields

$$\begin{aligned} \limsup_{\varepsilon \rightarrow 0} \left| \varepsilon \langle f, Q_\varepsilon(g) \rangle_{\ell^2(I)} + \frac{1}{\text{Var}} \sum_{i,j \in I} f_i g_j |\sigma(i) - \sigma(j)| \right| &= \limsup_{\varepsilon \rightarrow 0} \left(\varepsilon O_\eta(1) + O\left(\max_{w \in [-\eta, \eta]} |\delta_w| \right) \right) \|f\| \|g\| \\ &= O\left(\max_{w \in [-\eta, \eta]} |\delta_w| \right) \|f\| \|g\| ; \end{aligned}$$

since the above holds for all small enough $\eta > 0$ and $\lim_{w \rightarrow 0} \delta_w = 0$, we get finally that

$$\langle f, Q_\varepsilon(g) \rangle_{\ell^2(I)} \sim_{\varepsilon \rightarrow 0} -\frac{1}{\varepsilon \text{Var}} \sum_{i,j \in I} f_i g_j |\sigma(i) - \sigma(j)|.$$

Let $S : \mathbb{C}_0^I \rightarrow \mathbb{C}^I$ be the operator defined by

$$\langle f, S(g) \rangle_{\ell^2(I)} = - \sum_{i,j \in I} f_i g_j |\sigma(i) - \sigma(j)|.$$

Then S is symmetric and irreducible in the sense of Definition 1.13. Indeed, for all $i \neq j \in I$,

$$\langle \mathbf{1}_i - \mathbf{1}_j, S(\mathbf{1}_i - \mathbf{1}_j) \rangle_{\ell^2(I)} = 2 |\sigma(i) - \sigma(j)| > 0.$$

Let R' be the unique irreducible bi-L-matrix such that $R'_0 = S^{-1}$. By Theorem 0.1,

$$P_\varepsilon = \text{Id} - \varepsilon \text{Var } R' + o(\varepsilon);$$

setting $t = \varepsilon^{-1}$, all is left is to check that $R' = R$, or in other words, that $R_0 = S^{-1}$.

Asymptotics of the transition matrix P_ε .

We now use the assumption that $I = \{1, \dots, |I|\}$ and that σ is increasing, which always holds up to permutation of I . We shall work with a convenient basis for \mathbb{C}_0^I . Set $e_i^{i+1} := \mathbf{1}_{i+1} - \mathbf{1}_i$ for $1 \leq i < |I|$. Set also $\Delta_i^j := |\sigma(i) - \sigma(j)|$.

Let $\widehat{S} : \mathbb{C}^I \rightarrow \mathbb{C}^I$ such that $\widehat{S}_{ij} = -\Delta_i^j$, so that S is the composition of $\widehat{S}|_{\mathbb{C}_0^I} : \mathbb{C}_0^I \rightarrow \mathbb{C}^I$ with the projection parallel to constants from \mathbb{C}^I to \mathbb{C}_0^I . Then, for $1 \leq i < |I|$ and $j \in I$,

$$(\widehat{S}e_i^{i+1})_j = \Delta_i^j - \Delta_{i+1}^j = \begin{cases} -\Delta_i^{i+1} & \text{if } j \leq i, \\ \Delta_i^{i+1} & \text{if } j \geq i+1. \end{cases}$$

For $j < i$, the non-zero coefficients of the j th line of R are all in the range $\{1, \dots, i\}$, so that

$$(R\widehat{S}e_i^{i+1})_j = -\Delta_i^{i+1}(R\mathbf{1})_j = 0.$$

Likewise, $(R\widehat{S}e_i^{i+1})_j = 0$ for $j \geq i+2$. The last two cases $j = i$ and $j = i+1$ finally yield $R\widehat{S}e_i^{i+1} = e_i^{i+1}$ for all i . As R preserves \mathbb{C}_0^I , its restriction R_0 to \mathbb{C}_0^I is the inverse of S . \square

Remark 6.2 (Construction of R).

One can also use a probabilistic argument which illuminates the choice of the matrix R . As the asymptotics is, up to the variance, the same for all processes with \mathbb{L}^2 increments, it is enough to compute R in a specific example. For the simple random walk, in particular, R can be computed explicitly by a martingale argument.

6.2 Computation of the potential: $d = 1$, Lévy jumps

We are now interested in processes in the basin of attraction of a Lévy stable distribution. We recall the definition of regular variation:

Definition 6.3 (Regular and slow variation).

For any real α , a real-valued, measurable, positive function L defined on an interval $[x_0, +\infty)$ is said to have regular variation of index α at infinity if, for all $x > 0$,

$$\lim_{y \rightarrow +\infty} \frac{L(xy)}{L(y)} = x^\alpha.$$

A function L defined on an interval $(0, x_0]$ is said to have regular variation of index α at 0 if $x \mapsto L(1/x)$ has regular variation of index $-\alpha$ at infinity.

A function with regular variation of index 0 is also said to have slow variation.

In addition to the general setting of Section 6, we assume that there exist $\alpha \in (1, 2)$, $c_-, c_+ \geq 0$ not both zero and L with regular variation of index α at infinity such that

$$\begin{aligned} \mu(F \geq x) &\sim_{x \rightarrow +\infty} \frac{c_+}{L(x)}, \\ \mu(F \leq -x) &\sim_{x \rightarrow +\infty} \frac{c_-}{L(x)}. \end{aligned}$$

In this setting, we are able to give explicit asymptotics for the potential matrices, but not to invert them in general. We aim to prove:

Proposition 6.4.

Let $([\mathbb{Z}], \tilde{\mu}, \tilde{T})$ be an ergodic and recurrent Markov \mathbb{Z} -extension of a Gibbs-Markov map (A, μ, T) with jump function $F : A \rightarrow \mathbb{Z}$. Assume furthermore that there exists $\alpha \in (1, 2)$, $c_-, c_+ \geq 0$ not both zero and L with regular variation of index α at infinity such that

$$\begin{aligned} \mu(F \geq x) &\sim_{x \rightarrow +\infty} \frac{c_+}{L(x)}, \\ \mu(F \leq -x) &\sim_{x \rightarrow +\infty} \frac{c_-}{L(x)}. \end{aligned}$$

Let I be non-empty and finite and $\sigma : I \hookrightarrow \mathbb{R}$ be injective. For $t > 0$, let $\sigma_t : I \hookrightarrow \mathbb{Z}$ be such that $\sigma_t(i) = t\sigma(i) + o(t)$ for all $i \in I$. Let P_t be the transition matrix of the Markov chain induced on $\Sigma_t := \sigma_t(I)$ and $Q_t : \mathbb{C}_0^I \rightarrow \mathbb{C}_0^I$ the associated family of potential matrices. Then, for all $f, g \in \mathbb{C}_0^I$,

$$\begin{aligned} \langle f, Q_t(g) \rangle_{\ell^2(I)} &=_{t \rightarrow +\infty} \frac{\sin(\alpha\pi)}{\pi [c_+^2 + c_-^2 + 2c_+c_- \cos(\alpha\pi)]} \frac{L(t)}{t} \\ &\quad \cdot \sum_{i, j \in I} f_i g_j |\sigma(i) - \sigma(j)|^{\alpha-1} (c_+ \mathbf{1}_{\sigma(j) > \sigma(i)} + c_- \mathbf{1}_{\sigma(j) < \sigma(i)}) + o\left(\frac{L(t)}{t}\right). \end{aligned} \quad (6.6)$$

As a consequence, there exists an irreducible bi- L -matrix R such that

$$P_t =_{t \rightarrow +\infty} \text{Id} - \frac{t}{L(t)} R + o\left(\frac{t}{L(t)}\right). \quad (6.7)$$

Note that, as soon as $c_+ \neq c_-$ (i.e. F is in the basin of attraction of an asymmetric Lévy distribution), the operator S is not symmetric, and thus R is not symmetric either.

Proof. The structure of this demonstration follows that of the proof of Proposition 6.1.

We assume the setting of Proposition 6.1. By [4, Theorem 5.1]⁵, there exist $\vartheta > 0$, $\zeta \in [-1, 1]$ and a neighbourhood U of $0 \in \mathbb{T}^1$ such that, for all $w \in U$,

$$\lambda_w = e^{-\vartheta(1-i\zeta \tan(\pi\alpha/2) \operatorname{sgn}(w))L(|w|^{-1})^{-1}} + o(L(|w|^{-1})^{-1}).$$

Without loss of generality, L is assumed to be continuous. The sign function sgn in the above equation takes value 1 on \mathbb{R}_+^* and -1 on \mathbb{R}_-^* . The constants ϑ and ζ can in addition be expressed as functions of the initial data on F :

$$\begin{aligned} \vartheta &= (c_- + c_+) \Gamma(1 - \alpha) \cos\left(\frac{\pi\alpha}{2}\right), \\ \zeta &= \frac{c_+ - c_-}{c_+ + c_-}. \end{aligned}$$

In particular, the parameter ϑ quantifies the dispersion of F , while ζ quantifies its asymmetry. To make computations slightly lighter, we put $\zeta' := \zeta \tan(\pi\alpha/2)$.

We set $\varepsilon := t^{-1}$. By Proposition 5.3, for any small enough neighbourhood U of $0 \in \mathbb{T}$, for all $\varepsilon > 0$, for all $f, g \in \mathbb{C}_0^I$,

$$\langle f, Q_\varepsilon(g) \rangle_{\ell^2(I)} = \frac{1}{2\pi} \int_U \check{\mathcal{F}}_\varepsilon(f) \mathcal{F}_\varepsilon(g) \frac{1 + \delta_w}{1 - \lambda_w} dw + O_U(1) \|f\| \|g\|.$$

Note that $\check{\mathcal{F}}_\varepsilon(f)(w)$ and $\mathcal{F}_\varepsilon(g)(w)$ are both in $O(|w|)$ while the denominator is bounded from below by $c'|w|^2$ for some $c' > 0$ by Equation (6.3) and Potter's bound [7, Theorem 1.5.6]. This justifies that we took the limit in Equation (5.4).

Let us set

$$1 + \delta'_w := (1 + \delta_w) \frac{\vartheta(1 - i\zeta' \operatorname{sgn}(w))L(|w|^{-1})^{-1}}{1 - \lambda_w},$$

so that δ'_w is also a continuous function of w with $\lim_{w \rightarrow 0} \delta'_w = 0$. In addition, we choose $U = (-\eta, \eta)$ for small enough $\eta > 0$. Then:

$$\langle f, Q_\varepsilon(g) \rangle_{\ell^2(I)} = \frac{1}{2\pi} \int_{-\eta}^{\eta} \check{\mathcal{F}}_\varepsilon(f) \mathcal{F}_\varepsilon(g) \frac{(1 + i\zeta' \operatorname{sgn}(w))(1 + \delta'_w)}{\vartheta(1 + \zeta'^2)} L(|w|^{-1}) dw + O_\eta(1) \|f\| \|g\|. \quad (6.8)$$

As in the proof of Proposition 6.1, we split this integral in three parts, which can be dealt with roughly in the same way, with a few adaptations.

Control of δ'_w on the neighbourhood $(-\varepsilon, \varepsilon)$.

As in the proof of Proposition 6.1, for some constant $C \geq 0$,

$$\left| \int_{-\varepsilon}^{\varepsilon} \check{\mathcal{F}}_\varepsilon(f) \mathcal{F}_\varepsilon(g) \delta'_w L(|w|^{-1}) dw \right| \leq C \|f\| \|g\| \max_{w \in [-\eta, \eta]} |\delta'_w| \varepsilon^{-2} \int_0^\varepsilon w^2 L(w^{-1}) dw.$$

⁵In that theorem, (A, μ, T) is assumed to be mixing; however, ergodicity is enough, as can be seen e.g. by working with (A, μ, T^M) for $M \geq 1$ the period of T . In addition, we correct here a typographic mistake in the expression of $\Re \ln \lambda_w$.

But the function $w \mapsto w^2 L(w^{-1})$ has regular variation of index $2 - \alpha > 0$ near 0, so by Karamata's theorem [27] (alternatively, [7, Proposition 1.5.8]),

$$\left| \int_{-\varepsilon}^{\varepsilon} \check{\mathcal{F}}_{\varepsilon}(f) \mathcal{F}_{\varepsilon}(g) \delta'_w L(|w|^{-1}) \, dw \right| \leq C \|f\| \|g\| \max_{w \in [-\eta, \eta]} |\delta'_w| \varepsilon L(\varepsilon^{-1}).$$

Control of the error term δ'_w on $(-\eta, \eta) \setminus (-\varepsilon, \varepsilon)$.

For all $\iota \in (0, \alpha - 1)$,

$$\begin{aligned} & \left| \int_{(-\eta, \eta) \setminus (-\varepsilon, \varepsilon)} \check{\mathcal{F}}_{\varepsilon}(f) \mathcal{F}_{\varepsilon}(g) \delta'_w L(|w|^{-1}) \, dw \right| \\ & \leq C \|f\| \|g\| \max_{w \in [-\eta, \eta]} |\delta'_w| \int_{\varepsilon}^{\eta} L(|w|^{-1}) \, dw \\ & \leq C \|f\| \|g\| \max_{w \in [-\eta, \eta]} |\delta'_w| \varepsilon \int_1^{+\infty} L(\varepsilon^{-1} w^{-1}) \, dw \\ & \leq C_{\iota} \|f\| \|g\| \max_{w \in [-\eta, \eta]} |\delta'_w| \varepsilon \int_1^{+\infty} \frac{L(\varepsilon^{-1})}{w^{\alpha-\iota}} \, dw \\ & = O \left(\|f\| \|g\| \max_{w \in [-\eta, \eta]} |\delta'_w| \varepsilon L(\varepsilon^{-1}) \right), \end{aligned}$$

where we used Potter's bound [7, Theorem 1.5.6] to obtain the penultimate line, and the fact that $\alpha - \iota > 1$ to get the last line.

Main contribution to the integral (6.8).

Now let us focus on the remaining term. Again we split $\check{\mathcal{F}}_{\varepsilon}(f) \mathcal{F}_{\varepsilon}(g)$ along its frequencies. For all $i, j \in I$:

$$\begin{aligned} & \int_{-\eta}^{\eta} \left(e^{i\varepsilon^{-1} w(\sigma(i) - \sigma(j) + o(1))} - 1 \right) (1 + i\zeta' \operatorname{sgn}(w)) L(|w|^{-1}) \, dw \\ & = \varepsilon \int_{-\varepsilon^{-1}\eta}^{\varepsilon^{-1}\eta} \left(e^{iw(\sigma(i) - \sigma(j) + o(1))} - 1 \right) (1 + i\zeta' \operatorname{sgn}(w)) L(\varepsilon^{-1} |w|^{-1}) \, dw \\ & = \varepsilon L(\varepsilon^{-1}) \int_{\mathbb{R}} \frac{(e^{iw(\sigma(i) - \sigma(j))} - 1) (1 + i\zeta' \operatorname{sgn}(w))}{|w|^{\alpha}} \, dw + o(\varepsilon L(\varepsilon^{-1})), \end{aligned}$$

where we used on the last line the fact that $L(\varepsilon^{-1} |w|^{-1}) \sim_{\varepsilon \rightarrow 0} L(\varepsilon^{-1}) |w|^{-\alpha}$ to ensure pointwise convergence, and Potter's bounds and the dominated convergence theorem to ensure the convergence

of the integrals. From there we get

$$\begin{aligned}
& \int_{-\eta}^{\eta} \left(e^{i\varepsilon^{-1}w(\sigma(i)-\sigma(j)+o(1))} - 1 \right) (1 + i\zeta' \operatorname{sgn}(w)) L(|w|^{-1}) \, dw \\
&= \varepsilon L(\varepsilon^{-1}) \int_0^{+\infty} \left[\frac{(e^{iw(\sigma(i)-\sigma(j))} - 1) (1 + i\zeta')}{w^\alpha} + \frac{(e^{-iw(\sigma(i)-\sigma(j))} - 1) (1 - i\zeta')}{w^\alpha} \right] \, dw + o(\varepsilon L(\varepsilon^{-1})) \\
&= 2\varepsilon L(\varepsilon^{-1}) |\sigma(i) - \sigma(j)|^{\alpha-1} \Gamma(1 - \alpha) \Re \left[(1 + i\zeta') e^{-i\frac{(\alpha-1)\pi}{2} \operatorname{sgn}(\sigma(i)-\sigma(j))} \right] + o(\varepsilon L(\varepsilon^{-1})) \\
&= 2\varepsilon L(\varepsilon^{-1}) |\sigma(i) - \sigma(j)|^{\alpha-1} \Gamma(1 - \alpha) \left[\cos\left(\frac{(\alpha-1)\pi}{2}\right) + \zeta' \operatorname{sgn}(\sigma(i) - \sigma(j)) \sin\left(\frac{(\alpha-1)\pi}{2}\right) \right] \\
&\quad + o(\varepsilon L(\varepsilon^{-1})). \\
&= 2\varepsilon L(\varepsilon^{-1}) |\sigma(i) - \sigma(j)|^{\alpha-1} \Gamma(1 - \alpha) \sin\left(\frac{\alpha\pi}{2}\right) [1 + \zeta \operatorname{sgn}(\sigma(j) - \sigma(i))] + o(\varepsilon L(\varepsilon^{-1})).
\end{aligned}$$

where the integrals are evaluated using [18, Chap. XVII.4, 4.11]. Reintroducing the constant factors of Equation (6.8) and replacing ϑ and ζ by their values then yield:

$$\begin{aligned}
& \frac{1}{2\pi} \int_{-\eta}^{\eta} \left(e^{i\varepsilon^{-1}w(\sigma(i)-\sigma(j)+o(1))} - 1 \right) \frac{1 + i\zeta' \operatorname{sgn}(w)}{\vartheta(1 + \zeta'^2)} L(|w|^{-1}) \, dw \\
&= \varepsilon L(\varepsilon^{-1}) |\sigma(i) - \sigma(j)|^{\alpha-1} \frac{2\Gamma(1 - \alpha) \sin\left(\frac{\alpha\pi}{2}\right) \left[1 + \frac{c_+ - c_-}{c_+ + c_-} \operatorname{sgn}(\sigma(j) - \sigma(i)) \right]}{2\pi(c_+ + c_-) \Gamma(1 - \alpha) \cos\left(\frac{\alpha\pi}{2}\right) \left(1 + \left(\frac{c_+ - c_-}{c_+ + c_-}\right)^2 \tan^2\left(\frac{\alpha\pi}{2}\right) \right)} \\
&\quad + o(\varepsilon L(\varepsilon^{-1})) \\
&= \varepsilon L(\varepsilon^{-1}) |\sigma(i) - \sigma(j)|^{\alpha-1} \frac{\sin\left(\frac{\alpha\pi}{2}\right) \cos\left(\frac{\alpha\pi}{2}\right) [(c_+ + c_-) + (c_+ - c_-) \operatorname{sgn}(\sigma(j) - \sigma(i))]}{\pi((c_+ + c_-)^2 \cos^2\left(\frac{\alpha\pi}{2}\right) + (c_+ - c_-)^2 \sin^2\left(\frac{\alpha\pi}{2}\right))} \\
&\quad + o(\varepsilon L(\varepsilon^{-1})) \\
&= \frac{\sin(\alpha\pi) |\sigma(i) - \sigma(j)|^{\alpha-1} (c_+ \mathbf{1}_{\sigma(j) > \sigma(i)} + c_- \mathbf{1}_{\sigma(j) < \sigma(i)})}{\pi(c_+^2 + c_-^2 + 2c_- c_+ \cos(\alpha\pi))} \varepsilon L(\varepsilon^{-1}) + o(\varepsilon L(\varepsilon^{-1})).
\end{aligned}$$

Let us set

$$\langle f, S(g) \rangle_{\ell^2(I)} := \sum_{i,j \in I} f_i g_j \frac{\sin(\alpha\pi) |\sigma(i) - \sigma(j)|^{\alpha-1} (c_+ \mathbf{1}_{\sigma(j) > \sigma(i)} + c_- \mathbf{1}_{\sigma(j) < \sigma(i)})}{\pi(c_+^2 + c_-^2 + 2c_- c_+ \cos(\alpha\pi))}.$$

After summing over $i, j \in I$, we obtain

$$\frac{1}{2\pi} \int_{-\eta}^{\eta} \check{\mathcal{F}}_\varepsilon(f) \mathcal{F}_\varepsilon(g) \frac{1 + i\zeta' \operatorname{sgn}(w)}{\vartheta(1 + \zeta'^2)} L(|w|^{-1}) \, dw = \varepsilon L(\varepsilon^{-1}) \langle f, S(g) \rangle_{\ell^2(I)} + o(\varepsilon L(\varepsilon^{-1})).$$

Then, as in the proof of Proposition 6.1, we can control the error terms involving δ'_w to get

$$\langle f, Q_\varepsilon(g) \rangle_{\ell^2(I)} = \varepsilon L(\varepsilon^{-1}) \langle f, S(g) \rangle_{\ell^2(I)} + o(\varepsilon L(\varepsilon^{-1})),$$

which, after replacing ε by t^{-1} , finishes the proof of the first part of Proposition 6.4.

In addition, for all $i \neq j \in I$,

$$\langle \mathbf{1}_i - \mathbf{1}_j, S(\mathbf{1}_i - \mathbf{1}_j) \rangle_{\ell^2(I)} = \frac{(c_+ + c_-) |\sin(\alpha\pi)|}{\pi [c_+^2 + c_-^2 + 2c_+c_- \cos(\alpha\pi)]} |\sigma(i) - \sigma(j)|^{\alpha-1} > 0,$$

so that S is irreducible in the sense of Definition 1.13. By Theorem 0.1, there exists an irreducible bi-L-matrix R such that

$$P_\varepsilon =_{\varepsilon \rightarrow 0} \text{Id} - \frac{1}{\varepsilon L(\varepsilon^{-1})} R + o\left(\frac{1}{\varepsilon L(\varepsilon^{-1})}\right);$$

replacing ε by t^{-1} finishes the proof. \square

Example 6.5 (Asymmetric Lévy distributions).

While we have no general explicit expression for R , it can be computed on given examples. Let us consider for instance the case where $c_- = 0$ and, without loss of generality, $c_+ = 1$. This corresponds to a Lévy distribution which is maximally asymmetric, supported of \mathbb{R}_+ . Take, for instance, $I = \{A, B, C\}$ with $(\sigma(A), \sigma(B), \sigma(C)) = (-1, 0, 1)$.

Set $e_1 := \mathbf{1}_C - \mathbf{1}_B$ and $e_2 := \mathbf{1}_B - \mathbf{1}_A$. One computes

$$\begin{aligned} \langle e_1, S(e_1) \rangle_{\ell^2(I)} &= \frac{|\sin(\alpha\pi)|}{\pi}; & \langle e_1, S(e_2) \rangle_{\ell^2(I)} &= 0; \\ \langle e_2, S(e_1) \rangle_{\ell^2(I)} &= -(2 - 2^{\alpha-1}) \frac{|\sin(\alpha\pi)|}{\pi}; & \langle e_2, S(e_2) \rangle_{\ell^2(I)} &= \frac{|\sin(\alpha\pi)|}{\pi}. \end{aligned}$$

Since $\langle e_i, e_j \rangle_{\ell^2(I)} = 2$ if $i = j$ and -1 otherwise, we can write S in the basis (e_1, e_2) :

$$S = \frac{|\sin(\alpha\pi)|}{3\pi} \begin{pmatrix} 2^{\alpha-1} & 1 \\ 2^\alpha - 3 & 2 \end{pmatrix},$$

whence

$$S^{-1} = R_0 = \frac{\pi}{|\sin(\alpha\pi)|} \begin{pmatrix} 2 & -1 \\ 3 - 2^\alpha & 2^{\alpha-1} \end{pmatrix}.$$

We can then recover, in the basis $(\mathbf{1}_A, \mathbf{1}_B, \mathbf{1}_C)$,

$$R = \frac{\pi}{|\sin(\alpha\pi)|} \begin{pmatrix} 1 & -(2^{\alpha-1} - 1) & -(2 - 2^{\alpha-1}) \\ -1 & 2^{\alpha-1} & -(2^{\alpha-1} - 1) \\ 0 & -1 & 1 \end{pmatrix}, \quad (6.9)$$

and $P_t =_{t \rightarrow +\infty} \text{Id} - \frac{t}{L(t)} R + o(tL(t^{-1}))$ by Proposition 6.4. The first term of the last line is 0, which means that transitions from $\sigma_t(C) \sim t$ to $\sigma_t(A) \sim -t$ avoiding 0 have low probability (in $o(tL(t^{-1}))$). Transitions from $\sigma_t(A) \sim -t$ to $\sigma_t(C) \sim t$ avoiding 0 have a much higher probability.

This is expected: one can find random walks under these constraints whose jumps are supported on $[-1, +\infty)$, in which case transitions from $\sigma_t(C)$ to $\sigma_t(A)$ avoiding 0 are forbidden.

The matrix R of Equation (6.9) has other interesting features. If α is close to 2, as expected, the matrix R is close to the one of the \mathbb{L}^2 case, written in Proposition 6.1. Transitions occur mostly between neighbours, that is, between $\sigma_t(A)$ and $\sigma_t(B)$ or between $\sigma_t(B)$ and $\sigma_t(C)$. If α is close to 1, on the other hand, the transitions occur mostly in a circular way: from $\sigma_t(A)$ to $\sigma_t(C)$, or from $\sigma_t(C)$ to $\sigma_t(B)$, or from $\sigma_t(B)$ to $\sigma_t(A)$.

Example 6.6 (Symmetric Lévy distributions).

Let us present briefly the symmetric case. Without loss of generality, we assume that $c_- = c_+ = 1$. We take $I = \{A, B, C\}$ with $(\sigma(A), \sigma(B), \sigma(C)) = (-1, 0, 1)$, as in Example 6.5. Similar computations yield

$$R = \frac{2\pi}{2^{\alpha-1}(4 - 2^{\alpha-1})|\tan(\frac{\alpha\pi}{2})|} \begin{pmatrix} 2 & -2^{\alpha-1} & -(2 - 2^{\alpha-1}) \\ -2^{\alpha-1} & 2^\alpha & -2^{\alpha-1} \\ -(2 - 2^{\alpha-1}) & -2^{\alpha-1} & 2 \end{pmatrix}, \quad (6.10)$$

and $P_t =_{t \rightarrow +\infty} \text{Id} - \frac{t}{L(t)}R + o(tL(t^{-1}))$ by Proposition 6.4.

If α is close to 2, as expected, the matrix R is close to the one of the \mathbb{L}^2 case, written in Proposition 6.1. If α is close to 1, on the other hand, the transitions are close to the symmetric Cauchy case, written in Proposition 6.8.

6.3 Computation of the potential: $d = 1$, Cauchy jumps

We include some distributions for the jumps in the basin of attraction of a 1-stable law. These are of particular interest for at least two reasons. First, they occur in geometric settings, such as the geodesic flow on $\mathbb{C} \setminus \mathbb{Z}$ with a translation-invariant hyperbolic metric [2, 3]. In addition, in the context of the current work, we can compute explicitly the asymptotics of their transition matrices $(P_t)_{t>0}$ and not just the asymptotic potential operator S .

Getting exhaustive conditions ensuring that a given distribution is in the basin of attraction of a 1-stable law is a notoriously difficult problem. As in [40, Corollary 2.9], we choose to make a spectral assumption which, while very restrictive⁶, includes symmetric distributions. The work of J. Aaronson and M. Denker offers some explicit conditions on the tails of F which guarantee that Hypothesis 6.7 is satisfied [2].

Hypothesis 6.7 (Basin of attraction of 1-stable distributions).

There exist $\vartheta > 0$, $\zeta \in \mathbb{R}$ and L with regular variation of index 1 at infinity such that

$$\int_A e^{iwF} d\mu =_{w \rightarrow 0} e^{-\vartheta(1-i\zeta \text{sgn}(w))L(|w|^{-1})^{-1}} + o(L(|w|^{-1})^{-1}). \quad (6.11)$$

Furthermore, we then set

$$J(t) := \int_C \frac{L(s)}{s^2} ds,$$

which is well-defined for all large enough C and all $t \geq C$.

We then get:

Proposition 6.8.

Let $([\mathbb{Z}], \tilde{\mu}, \tilde{T})$ be an ergodic and recurrent Markov \mathbb{Z} -extension of a Gibbs-Markov map (A, μ, T) with jump function $F : A \rightarrow \mathbb{Z}$. Assume furthermore that F satisfies Hypothesis 6.7.

Let I be non-empty and finite and $\sigma : I \hookrightarrow \mathbb{R}$ be injective. For $t > 0$, let $\sigma_t : I \hookrightarrow \mathbb{Z}$ be such that $\sigma_t(i) = t\sigma(i) + o(t)$ for all $i \in I$. Let P_t be the transition matrix of the Markov chain induced on $\Sigma_t := \sigma_t(I)$. Then

$$P_t =_{t \rightarrow +\infty} \text{Id} - \frac{\pi\vartheta(1 + \zeta^2)}{J(t)}R + o(J(t)^{-1}),$$

⁶In particular, the H_1 and H_2 terms appearing in [2, Theorem 2] must cancel up to an error in $o(L(|w|^{-1})^{-1})$.

where R is the irreducible, symmetric bi- L -matrix defined by

$$\begin{cases} R_{ij} &= -\frac{1}{|I|} & \text{whenever } i \neq j \in I, \\ R_{ii} &= \frac{|I|-1}{|I|} & \forall i \in I. \end{cases} \quad (6.12)$$

Under the hypotheses of Proposition 6.8, and setting

$$a(t) := \frac{\pi\vartheta(1+\zeta^2)}{|I|J(t)},$$

the transition matrices $(P_t)_{t>0}$ have the following graphical representation:

$$P_t = \begin{pmatrix} 1 - (|I| - 1)a(t) & a(t) & \dots & a(t) & a(t) \\ a(t) & 1 - (|I| - 1)a(t) & \dots & a(t) & a(t) \\ \vdots & \vdots & \ddots & \vdots & \vdots \\ a(t) & a(t) & \dots & 1 - (|I| - 1)a(t) & a(t) \\ a(t) & a(t) & \dots & a(t) & 1 - (|I| - 1)a(t) \end{pmatrix} + o(J(t)^{-1}).$$

It is possible to get less trivial limit matrices if one looks at shapes whose points lie at different spatial scales. One may consider, for instance, $L(t) \sim Ct$, so that $J(t) \sim C \ln(t)$, and $\|\sigma_t(i) - \sigma_t(j)\| \sim t^{\max\{r(i), r(j)\}}$ for some function $r : I \rightarrow (0, +\infty)$.

Before proving Proposition 6.8, we introduce a technical lemma:

Lemma 6.9.

Let $([\mathbb{Z}], \tilde{\mu}, \tilde{T})$ be an ergodic and recurrent Markov \mathbb{Z} -extension of a Gibbs-Markov map (A, μ, T) with jump function $F : A \rightarrow \mathbb{Z}$. Assume furthermore that F satisfies Hypothesis 6.7. Then, for all large enough C ,

$$\int_C^{+\infty} \frac{L(t)}{t^2} dt = +\infty.$$

Proof. By Halmos' recurrence theorem [24], if $([\mathbb{Z}], \tilde{\mu}, \tilde{T})$ is recurrent, then

$$\sum_{n=0}^{+\infty} \tilde{\mu}((x, p) \in [0] \text{ and } \tilde{T}^n(x, p) \in [0]) = \sum_{n=0}^{+\infty} \mu(S_n F = 0) = +\infty.$$

As in the proof of Proposition 5.3, we can express this sum using the Fourier transform and twisted

transfer operators. For all small enough $\eta > 0$, such that in particular $|\mu_w(\mathbf{1})| \leq 2\pi$ on $(-\eta, \eta)$:

$$\begin{aligned}
\sum_{n=0}^{+\infty} \mu(S_n F = 0) &= \lim_{\rho \rightarrow 1^-} \sum_{n=0}^{+\infty} \rho^n \mu(S_n F = 0) \\
&= \lim_{\rho \rightarrow 1^-} \sum_{n=0}^{+\infty} \rho^n \int_A \frac{1}{2\pi} \int_{\mathbb{T}^1} e^{iwS_n F} dw d\mu \\
&= \frac{1}{2\pi} \lim_{\rho \rightarrow 1^-} \sum_{n=0}^{+\infty} \rho^n \int_{\mathbb{T}^1} \int_A \mathcal{L}_w^n(\mathbf{1}) d\mu dw \\
&= \frac{1}{2\pi} \lim_{\rho \rightarrow 1^-} \int_{\mathbb{T}^1} \int_A (\text{Id} - \rho \mathcal{L}_w)^{-1}(\mathbf{1}) d\mu dw \\
&\leq \frac{1}{2\pi} \limsup_{\rho \rightarrow 1^-} \int_{-\eta}^{\eta} \frac{|\mu_w(\mathbf{1})|}{|1 - \rho \lambda_w|} dw + O(1) \\
&\leq \int_{-\eta}^{\eta} \frac{1}{|1 - \lambda_w|} dw + O(1).
\end{aligned}$$

By [3, Theorem 2], under Condition (6.11) and with the same constants,

$$\lambda_w = e^{-\vartheta(1-i\zeta \operatorname{sgn}(w))L(|w|^{-1})^{-1}} + o(L(|w|^{-1})^{-1}).$$

Taking real parts and possibly a lower value of η , the function $|1 - \lambda_w|$ has a lower bound in $\vartheta L(|w|^{-1})^{-1}/2$, and in addition

$$\int_{-\eta}^{\eta} \frac{2}{\vartheta L(|w|^{-1})^{-1}} dw = \frac{4}{\vartheta} \int_{\eta^{-1}}^{+\infty} \frac{L(w)}{w^2} dw,$$

which must diverge. □

We can now proceed to the proof of Proposition 6.8.

Proof of Proposition 6.8. The structure of this demonstration follows that of the proofs of Propositions 6.1 and 6.4.

We assume the setting of Proposition 6.8. In particular, using Hypothesis 6.7, let $\vartheta > 0$, $\zeta \in \mathbb{R}$ and L with regular variation of index 1 at infinity such that

$$\int_A e^{iwF} d\mu =_{w \rightarrow 0} e^{-\vartheta(1-i\zeta \operatorname{sgn}(w))L(|w|^{-1})^{-1}} + o(L(|w|^{-1})^{-1}).$$

We set $\varepsilon := t^{-1}$. With exact the same reasoning as in the beginning of the proof of Proposition 6.4, we get for all $f, g \in \mathbb{C}_0^I$:

$$\langle f, Q_\varepsilon(g) \rangle_{\ell^2(I)} = \frac{1}{2\pi} \int_{-\eta}^{\eta} \check{\mathcal{F}}_\varepsilon(f) \mathcal{F}_\varepsilon(g) \frac{(1 + i\zeta \operatorname{sgn}(w))(1 + \delta'_w)}{\vartheta(1 + \zeta^2)} L(|w|^{-1}) dw + O_\eta(1) \|f\| \|g\|, \quad (6.13)$$

where $\lim_{w \rightarrow 0} \delta'_w = 0$.

As in the proof of Proposition 6.4, we split this integral in three parts; however these parts are different:

- the whole integral on a small neighbourhood $(-\varepsilon, \varepsilon)$ of 0, which shall be negligible because $(\check{\mathcal{F}}_\varepsilon(f)\mathcal{F}_\varepsilon(g))(w)$ is small near 0, with a small additional gain thanks to [7, Proposition 1.5.9b].
- the integral involving the error term δ'_w on $(-\eta, \eta) \setminus (-\varepsilon, \varepsilon)$, which shall be negligible because δ'_w is small and $L(|w|^{-1})$ is large.
- the integral on $(-\eta, \eta) \setminus (-\varepsilon, \varepsilon)$ without the error term δ'_w , which is the main contribution to $\langle f, Q_\varepsilon(g) \rangle_{\ell^2(I)}$.

Another meaningful difference will reside in the computation of the asymptotics of the main part: the non-zero frequencies of $\check{\mathcal{F}}_\varepsilon(f)\mathcal{F}_\varepsilon(g)$ will yield a negligible contribution by an argument *à la* Riemann-Lebesgue.

Control of the integral on the neighbourhood $(-\varepsilon, \varepsilon)$.

The exact same computation as in the proof of Proposition 6.4 yields

$$\int_{-\varepsilon}^{\varepsilon} \check{\mathcal{F}}_\varepsilon(f)\mathcal{F}_\varepsilon(g)(1 + \delta'_w)L(|w|^{-1}) dw = \|f\| \|g\| O(\varepsilon L(\varepsilon^{-1})).$$

In addition, since $t^{-2}L(t)$ is not integrable by Lemma 6.9, we can apply [7, Proposition 1.5.9b] to get that $t^{-1}L(t) = o(J(t))$, or by a change of variable

$$\int_{-\varepsilon}^{\varepsilon} \check{\mathcal{F}}_\varepsilon(f)\mathcal{F}_\varepsilon(g)(1 + \delta'_w)L(|w|^{-1}) dw = \|f\| \|g\| o(J(\varepsilon^{-1})).$$

Control of the error term δ'_w on $(-\eta, \eta) \setminus (-\varepsilon, \varepsilon)$.

On $(-\eta, \eta) \setminus (-\varepsilon, \varepsilon)$, we get

$$\begin{aligned} & \left| \int_{(-\eta, \eta) \setminus (-\varepsilon, \varepsilon)} \check{\mathcal{F}}_\varepsilon(f)\mathcal{F}_\varepsilon(g)\delta'_w L(|w|^{-1}) dw \right| \\ & \leq C \|f\| \|g\| \max_{w \in [-\eta, \eta]} |\delta'_w| \int_{\varepsilon}^{\eta} L(w^{-1}) dw \\ & = C \|f\| \|g\| \max_{w \in [-\eta, \eta]} |\delta'_w| \int_{\eta^{-1}}^{\varepsilon^{-1}} \frac{L(w)}{w^2} dw \\ & = C \|f\| \|g\| \max_{w \in [-\eta, \eta]} |\delta'_w| [J(\varepsilon^{-1}) - J(\eta^{-1})] \\ & \leq C \|f\| \|g\| \max_{w \in [-\eta, \eta]} |\delta'_w| J(\varepsilon^{-1}). \end{aligned}$$

Main contribution to the integral (6.13).

Now let us focus on the remaining term. Again we split $\check{\mathcal{F}}_\varepsilon(f)\mathcal{F}_\varepsilon(g)$ along its frequencies. Without loss of generality, L can be chosen increasing. The function $w \mapsto L(w^{-1})$ is then decreasing on (ε, η) .

By the Riemann-Stieltjes version of the integration by parts [5, Theorem 7.6], whenever $i \neq j \in I$,

$$\begin{aligned}
& \int_{\varepsilon}^{\eta} e^{i\varepsilon^{-1}w(\sigma(i)-\sigma(j)+o(1))} L(w^{-1}) \, dw \\
&= \frac{\varepsilon}{\sigma(i) - \sigma(j) + o(1)} \left[e^{i\varepsilon^{-1}w(\sigma(i)-\sigma(j)+o(1))} L(w^{-1}) \right]_{\varepsilon}^{\eta} \\
&\quad - \frac{\varepsilon}{\sigma(i) - \sigma(j) + o(1)} \int_{\varepsilon}^{\eta} e^{i\varepsilon^{-1}w(\sigma(i)-\sigma(j)+o(1))} [L(w^{-1})]' \, dw \\
&= O(\varepsilon L(\varepsilon^{-1})) \\
&= o(J(\varepsilon^{-1})),
\end{aligned}$$

where we again applied Lemma 6.9 and [7, Proposition 1.5.9b]. The integral over $(-\eta, -\varepsilon)$ can be dealt with in the same way. If $i = j$, then

$$\begin{aligned}
\int_{(-\eta, \eta) \setminus (-\varepsilon, \varepsilon)} e^{i\varepsilon^{-1}w(\sigma(j)-\sigma(i)+o(1))} (1 + i\zeta \operatorname{sgn}(w)) L(|w|^{-1}) \, dw &= 2 \int_{\varepsilon}^{\eta} L(w^{-1}) \, dw \\
&= 2 [J(\varepsilon^{-1}) - J(\eta^{-1})] \\
&\sim_{\varepsilon \rightarrow 0} 2J(\varepsilon^{-1}).
\end{aligned}$$

Finally, summing up everything,

$$\langle f, Q_{\varepsilon}(g) \rangle_{\ell^2(I)} = \frac{J(\varepsilon^{-1})}{\pi\vartheta(1 + \zeta^2)} \langle f, g \rangle_{\ell^2(I)} + \|f\| \|g\| o(J(\varepsilon^{-1})) + \|f\| \|g\| \max_{w \in [-\eta, \eta]} |\delta'_w| O(J(\varepsilon^{-1})).$$

By the same argument as in the proof of Proposition 6.1, making η smaller as ε vanishes, we get

$$\langle f, Q_{\varepsilon}(g) \rangle_{\ell^2(I)} = \frac{J(\varepsilon^{-1})}{\pi\vartheta(1 + \zeta^2)} \langle f, g \rangle_{\ell^2(I)} + \|f\| \|g\| o(J(\varepsilon^{-1})),$$

or, in other words,

$$Q_{\varepsilon} \sim_{\varepsilon \rightarrow 0} \frac{J(\varepsilon^{-1})}{\pi\vartheta(1 + \zeta^2)} \operatorname{Id}_{\mathbb{C}_0^I}.$$

Asymptotics of the transition matrix P_{ε} .

The identity is irreducible in the sense of Definition 1.13. Hence we can apply Theorem 0.1 with $S = \operatorname{Id}_{\mathbb{C}_0^I}$:

$$(\operatorname{Id} - P_{\varepsilon})_{\mathbb{C}_0^I \rightarrow \mathbb{C}_0^I} \sim_{\varepsilon \rightarrow 0} \frac{\pi\vartheta(1 + \zeta^2)}{J(\varepsilon^{-1})} \operatorname{Id}_{\mathbb{C}_0^I}.$$

The last step is to get the asymptotics for P_{ε} on \mathbb{C}^I . Writing ϖ_I the projection parallel to constants onto \mathbb{C}_0^I ,

$$\begin{aligned}
P_{\varepsilon} &= \mathbf{1} \otimes \mu_I + (P_{\varepsilon})_{\mathbb{C}_0^I \rightarrow \mathbb{C}_0^I} \varpi_I \\
&= \mathbf{1} \otimes \mu_I + \left(1 - \frac{\pi\vartheta(1 + \zeta^2)}{J(\varepsilon^{-1})} \right) \varpi_I + o(J(\varepsilon^{-1})^{-1}) \\
&= \left(1 - \frac{\pi\vartheta(1 + \zeta^2)}{J(\varepsilon^{-1})} \right) \operatorname{Id} + \frac{\pi\vartheta(1 + \zeta^2)}{J(\varepsilon^{-1})} \mathbf{1} \otimes \mu_I + o(J(\varepsilon^{-1})^{-1}).
\end{aligned}$$

In other words, the diagonal terms of P_ε are all

$$1 - \frac{|I| - 1}{|I|} \frac{\pi \vartheta(1 + \zeta^2)}{J(\varepsilon^{-1})} + o(J(\varepsilon^{-1})^{-1}),$$

while the off-diagonal terms are all

$$\frac{1}{|I|} \frac{\pi \vartheta(1 + \zeta^2)}{J(\varepsilon^{-1})} + o(J(\varepsilon^{-1})^{-1});$$

replacing ε by t^{-1} finishes the proof. \square

6.4 Computation of the potential: $d = 2$, square integrable jumps

Finally, we tackle \mathbb{Z}^2 -extensions with square-integrable jumps. In addition to the general setting of Section 6, we assume in this Subsection that F is square-integrable and centered, the later condition being already implied by the first condition and the ergodicity of the extension.

Let Cov be the asymptotic covariance matrix of F , defined for all $u \in \mathbb{R}^2$ by:

$$\langle u, \text{Cov}(u) \rangle_{\mathbb{R}^2} := \int_A \langle F, u \rangle_{\mathbb{R}^2}^2 d\mu + 2 \sum_{n \geq 1} \int_A \langle F, u \rangle_{\mathbb{R}^2} \circ T^n \cdot \langle F, u \rangle_{\mathbb{R}^2} d\mu, \quad (6.14)$$

where the infinite series is taken in the sense of Cesàro. Since $([\mathbb{Z}^2], \tilde{\mu}, \tilde{T})$ is ergodic, $\langle F, u \rangle_{\mathbb{R}^2}$ is not a coboundary whenever $u \neq 0$ (otherwise the sums $S_n \langle F, u \rangle_{\mathbb{R}^2}$ would be almost surely bounded), and thus Cov is positive definite [21, Théorème 4.1.4].

The behaviour of the transition matrices is then similar to the Cauchy case (Proposition 6.8), with a statement given in the introduction (Proposition 0.2) and which we shall now prove.

Proof of Proposition 0.2. The structure of this demonstration is very close to that of Proposition 6.8. We assume the setting of Proposition 0.2 and set $\varepsilon := t^{-1}$. The main eigenvalue of \mathcal{L}_w then admits the expansion [21, Théorème 4.1.4]

$$\lambda_w = 1 - \frac{\langle w, \text{Cov}(w) \rangle}{2} + o(\|w\|^2). \quad (6.15)$$

With the exact same reasoning as in the beginning of the proof of Proposition 6.1, but with a two-dimensional Fourier transform, we get for all $f, g \in \mathbb{C}_0^I$ and all small enough neighborhood U of 0:

$$\langle f, Q_\varepsilon(g) \rangle_{\ell^2(I)} = \frac{1}{2\pi^2} \int_U \left(\check{\mathcal{F}}_\varepsilon(f) \mathcal{F}_\varepsilon(g) \right) (w) \frac{1 + \delta'_w}{\langle w, \text{Cov}(w) \rangle} dw + O_U(1) \|f\| \|g\|, \quad (6.16)$$

where $\lim_{w \rightarrow 0} \delta'_w = 0$.

We choose $U = \sqrt{\text{Cov}}B(0, \eta)$ for small enough $\eta > 0$. Then, after a change of variables:

$$\langle f, Q_\varepsilon(g) \rangle_{\ell^2(I)} = \frac{1}{2\pi^2 \sqrt{\det(\text{Cov})}} \int_{B(0, \eta)} \left(\check{\mathcal{F}}_\varepsilon(f) \mathcal{F}_\varepsilon(g) \right) (\sqrt{\text{Cov}}^{-1} w) \frac{1 + \delta'_{\sqrt{\text{Cov}}^{-1} w}}{\|w\|^2} dw + O_\eta(1) \|f\| \|g\|.$$

As in the proof of Proposition 6.8, we split this integral in three parts:

- in dimension 2, since both f and g have zero sum, the contribution of a small ball $B(0, \varepsilon)$ is in $O(1)$.
- the integral involving the error term δ'_w on $B(0, \eta) \setminus B(0, \varepsilon)$, which shall be negligible because δ'_w is small and $\|w\|^2$ is large.
- for the remainder, we split $\check{\mathcal{F}}_\varepsilon(f)\mathcal{F}_\varepsilon(g)$ along its different frequencies. Again, the frequency 0 has to be considered separately, and will give the main contribution to $\langle f, Q_\varepsilon g \rangle_{\ell^2(I)}$. The other frequencies will have a lower contribution thanks to cancellations *à la* Riemann-Lebesgue. Computations will be handled in polar coordinates, thanks to our choice of neighbourhood U .

For the third part and non-zero frequencies, we will subdivide the region $B(0, \eta) \setminus B(0, \varepsilon)$ in two parts: one close to the line orthogonal to the frequency vector, which shall be small, and the remaining part of the annulus, on which the Riemann-Lebesgue argument works out.

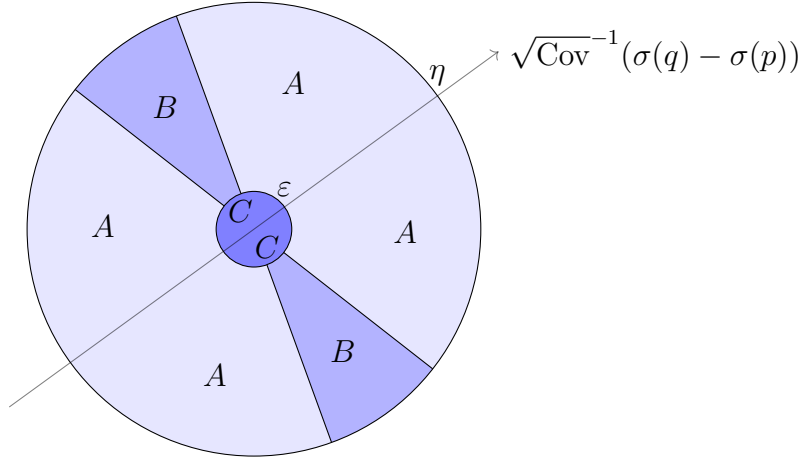

Figure 7: Regions of integration for non-zero frequencies. Light blue (A): negligible by a Riemann-Lebesgue argument. Middle blue (B): near the perpendicular to $\sqrt{\text{Cov}}^{-1}(\sigma(q) - \sigma(p))$; negligible because the area is arbitrarily small. Dark blue (C): a disc of radius ε ; negligible because the area is small and the function $\check{\mathcal{F}}_\varepsilon(f)\mathcal{F}_\varepsilon(g)$ cancels the denominator.

Control of the integral on the neighbourhood $B(0, \varepsilon)$.

Our usual computations, as in the proof of Proposition 6.1, give:

$$\begin{aligned} \int_{B(0, \varepsilon)} \left| \check{\mathcal{F}}_\varepsilon(f)\mathcal{F}_\varepsilon(g) \right| (\sqrt{\text{Cov}}^{-1} w) \frac{\left| 1 + \delta_{\sqrt{\text{Cov}}^{-1} w} \right|}{\|w\|^2} dw &\leq C \|f\| \|g\| \varepsilon^{-2} \int_{B(0, \varepsilon)} 1 dw \\ &\leq C \|f\| \|g\|. \end{aligned}$$

Control of the error term δ'_w on $B(0, \eta) \setminus B(0, \varepsilon)$.

On $B(0, \eta) \setminus B(0, \varepsilon)$, we get

$$\begin{aligned}
& \left| \int_{B(0, \eta) \setminus B(0, \varepsilon)} \left(\check{\mathcal{F}}_\varepsilon(f) \mathcal{F}_\varepsilon(g) \right) (\sqrt{\text{Cov}}^{-1} w) \frac{\delta_{\sqrt{\text{Cov}}^{-1} w}}{\|w\|^2} dw \right| \\
& \leq C \|f\| \|g\| \max_{w \in \sqrt{\text{Cov}} \cdot \overline{B}(0, \eta)} |\delta'_w| \int_{B(0, \eta) \setminus B(0, \varepsilon)} \frac{1}{\|w\|^2} dw \\
& = C \|f\| \|g\| \max_{w \in \sqrt{\text{Cov}} \cdot \overline{B}(0, \eta)} |\delta'_w| \int_\varepsilon^\eta \frac{2\pi}{r} dr \\
& \leq 2\pi C \|f\| \|g\| \max_{w \in \sqrt{\text{Cov}} \cdot \overline{B}(0, \eta)} |\delta'_w| \cdot |\ln(\varepsilon)|.
\end{aligned}$$

Main contribution to the integral (6.16).

Now let us focus on the remaining term. Again we split $\left(\check{\mathcal{F}}_\varepsilon(f) \mathcal{F}_\varepsilon(g) \right) (\sqrt{\text{Cov}}^{-1} w)$ along its frequencies. Fix some small $\kappa > 0$. For $i \neq j \in I$,

$$\int_{B(0, \eta) \setminus B(0, \varepsilon)} \frac{e^{i\langle \sqrt{\text{Cov}}^{-1} w, \varepsilon^{-1}(\sigma(i) - \sigma(j)) + o(\varepsilon^{-1}) \rangle}}{\|w\|^2} dw = \int_{\mathbb{S}_1} \int_\varepsilon^\eta \frac{e^{i\varepsilon^{-1} r \langle (\cos(\theta), \sin(\theta)), \sqrt{\text{Cov}}^{-1}(\sigma(j) - \sigma(i)) + o(1) \rangle}}{r} dr d\theta.$$

For fixed $\theta \in \mathbb{S}_1$, the inner integral can be bounded in two ways. First, we have the crude but general:

$$\left| \int_\varepsilon^\eta \frac{e^{i\varepsilon^{-1} r \langle (\cos(\theta), \sin(\theta)), \sqrt{\text{Cov}}^{-1}(\sigma(j) - \sigma(i)) + o(1) \rangle}}{r} dr \right| \leq \int_\varepsilon^\eta \frac{1}{r} dr = \ln(\eta) - \ln(\varepsilon) \leq |\ln(\varepsilon)|.$$

A second way uses an integration by parts:

$$\begin{aligned}
& \left| \int_\varepsilon^\eta \frac{e^{i\varepsilon^{-1} r \langle (\cos(\theta), \sin(\theta)), \sqrt{\text{Cov}}^{-1}(\sigma(j) - \sigma(i)) + o(1) \rangle}}{r} dr \right| \\
& = \left| \left[\frac{e^{i\varepsilon^{-1} r \langle (\cos(\theta), \sin(\theta)), \sqrt{\text{Cov}}^{-1}(\sigma(j) - \sigma(i)) + o(1) \rangle}}{\left(i\varepsilon^{-1} \langle (\cos(\theta), \sin(\theta)), \sqrt{\text{Cov}}^{-1}(\sigma(j) - \sigma(i)) + o(1) \rangle \right) r} \right]_\varepsilon^\eta \right. \\
& \quad \left. + \int_\varepsilon^\eta \frac{e^{i\varepsilon^{-1} r \langle (\cos(\theta), \sin(\theta)), \sqrt{\text{Cov}}^{-1}(\sigma(j) - \sigma(i)) + o(1) \rangle}}{\left(i\varepsilon^{-1} \langle (\cos(\theta), \sin(\theta)), \sqrt{\text{Cov}}^{-1}(\sigma(j) - \sigma(i)) + o(1) \rangle \right) r^2} dr \right| \\
& \leq \frac{2\varepsilon}{\left| \langle (\cos(\theta), \sin(\theta)), \sqrt{\text{Cov}}^{-1}(\sigma(j) - \sigma(i)) + o(1) \rangle \right|} \left(\frac{1}{\varepsilon} + \frac{1}{\eta} \right). \tag{6.17}
\end{aligned}$$

Let $K_{\eta, \varepsilon, i, j}$ be the set of values of θ such that the right hand-side of Equation (6.17) is smaller or equal to $\sqrt{|\ln(\varepsilon)|}$. Then $\lim_{\eta \rightarrow +\infty} \text{Leb}(K_{\eta, \varepsilon, i, j}) = 2\pi$, whence

$$\begin{aligned}
& \left| \int_{B(0, \eta) \setminus B(0, \varepsilon)} \frac{e^{i\langle \sqrt{\text{Cov}}^{-1} w, \varepsilon^{-1}(\sigma(i) - \sigma(j)) + o(\varepsilon^{-1}) \rangle}}{\|w\|^2} dw \right| \\
& \leq \int_{K_{\eta, \varepsilon, i, j}} \sqrt{|\ln(\varepsilon)|} d\theta + \int_{\mathbb{S}_1 \setminus K_{\eta, \varepsilon, i, j}} |\ln(\varepsilon)| d\theta \\
& \leq 2\pi \sqrt{|\ln(\varepsilon)|} + \text{Leb}(\mathbb{S}_1 \setminus K_{\eta, \varepsilon, i, j}) |\ln(\varepsilon)| \\
& = o(|\ln(\varepsilon)|).
\end{aligned}$$

The zero frequency term is comparatively easier to compute:

$$\int_{B(0,\eta)\setminus B(0,\varepsilon)} \frac{1}{\|w\|^2} dw = 2\pi \int_{\varepsilon}^{\eta} \frac{1}{r} dr = 2\pi (\ln(\eta) - \ln(\varepsilon)) \sim_{\varepsilon \rightarrow 0} 2\pi |\ln(\varepsilon)|.$$

Finally, summing up everything,

$$\langle f, Q_{\varepsilon}(g) \rangle_{\ell^2(I)} = \frac{|\ln(\varepsilon)|}{\pi \sqrt{\det(\text{Cov})}} \langle f, g \rangle_{\ell^2(I)} + \|f\| \|g\| \max_{w \in \sqrt{\text{Cov}} \cdot \bar{B}(0,\eta)} |\delta'_w| O(|\ln(\varepsilon)|) + \|f\| \|g\| o(|\ln(\varepsilon)|).$$

By the same argument as in the proof of Proposition 6.1, making η smaller as ε vanishes, we get

$$\langle f, Q_{\varepsilon}(g) \rangle_{\ell^2(I)} = \frac{|\ln(\varepsilon)|}{\pi \sqrt{\det(\text{Cov})}} \langle f, g \rangle_{\ell^2(I)} + \|f\| \|g\| o(|\ln(\varepsilon)|),$$

or, in other words,

$$Q_{\varepsilon} \sim_{\varepsilon \rightarrow 0} \frac{|\ln(\varepsilon)|}{\pi \sqrt{\det(\text{Cov})}} \text{Id}_{\mathbb{C}_0^I}.$$

The computation of the asymptotics of P_{ε} from those of Q_{ε} are then the same as in the end of the proof of Proposition 6.8. \square

A Gibbs-Markov maps

In this appendix, we compile definitions and technical results relative to Gibbs-Markov maps. In what follows, (A, α, d, μ, T) is a Gibbs-Markov map (see Definition 1.5).

A.1 Markov partitions and stopping times

We aim to define various partitions and filtrations related to Gibbs-Markov maps, so as to introduce stopping times. The central definition is that of a *cylinder*.

Definition A.1 (Cylinder).

For $n \geq 0$, a cylinder of length n is a non-trivial element of $\alpha_n := \bigvee_{k=0}^{n-1} T^{-k}\alpha$. It is given by a unique finite sequence $(a_k)_{0 \leq k < n}$ of elements of α such that $T(a_k) \cap a_{k+1}$ is non-negligible for all $0 \leq k < n-1$. Such a cylinder shall be denoted by $[a_0, \dots, a_{n-1}]$.

We denote by α^* the image partition, generated by $\{T(a) : a \in \alpha\}$. Since T is Markov, α^* is coarser than α .

With any Markov map comes a natural filtration given by $\mathcal{F}_n := \sigma(\alpha_n)$ for all $n \geq 0$. The σ -algebra \mathcal{F}_0 is trivial, while $\mathcal{A} = \mathcal{F}_{\infty} := \bigvee_{n \geq 0} \mathcal{F}_n$ is the Borel σ -algebra of (A, d) . From this filtration we define *stopping times*.

Definition A.2 (Stopping time). Let (A, α, d, μ, T) be a Gibbs-Markov map. Let $\varphi : A \rightarrow \mathbb{N} \cup \{+\infty\}$ be measurable. We say that φ is a stopping time if $\{\varphi \leq n\} \in \mathcal{F}_n$ for all $n \geq 0$, and $1 \leq \varphi < +\infty$ almost surely.

To any stopping time φ we associate a countable partition of A given by:

$$\alpha_{\varphi} := \bigcup_{n \geq 1} \{\bar{a} \in \alpha_n : \mu(\bar{a}) > 0 \text{ and } \bar{a} \subset \{\varphi = n\}\},$$

and a transformation defined by:

$$T_\varphi(x) := T^{\varphi(x)}(x),$$

which is well-defined almost everywhere.

In this article, and in opposition to other resources, we shall always require stopping times to be positive and finite, for the following reasons. If we did not require stopping times to be positive, then $\varphi \equiv 0$ would be a stopping time (and the only stopping time such that $\mu(\varphi = 0) > 0$), for which the partition the partition α_φ would be trivial. If we did not require stopping times to be finite, then T_φ may not be well-defined.

The iterates of T_φ can be directly related to stopping times. For any $n \geq 1$, we define:

$$\varphi^{(n)} = S_n^{T_\varphi} \varphi := \sum_{k=0}^{n-1} \varphi \circ T_\varphi^k. \quad (\text{A.1})$$

Then $T_\varphi^n = T_{\varphi^{(n)}}$. As the following lemma asserts, $\varphi^{(n)}$ is again a stopping time.

Lemma A.3.

Let (A, α, d, μ, T) be a Gibbs-Markov map. Let φ be a stopping time and $n \geq 1$. Then $\varphi^{(n)}$ is a stopping time.

Proof. We proceed by induction on n . For $n = 1$, the function $\varphi^{(1)} = \varphi$ is a stopping time. Let $n \geq 1$ and assume that $\varphi^{(n)}$ is a stopping time. We have

$$\varphi^{(n+1)} = \sum_{k=0}^n \varphi \circ T_\varphi^k = \varphi + \varphi^{(n)} \circ T_\varphi,$$

so that, for all $k \geq 0$:

$$\{\varphi^{(n+1)} \leq k\} = \bigcup_{j=0}^k \{\varphi \leq j\} \cap T^{-j} \{\varphi^{(n)} \leq k - j\}.$$

Let $0 \leq j \leq k$. Both φ and $\varphi^{(n)}$ are stopping times, so $\{\varphi \leq j\} \in \mathcal{F}_j$ and $\{\varphi^{(n)} \leq k - j\} \in \mathcal{F}_{k-j}$. It follows that

$$\{\varphi \leq j\} \cap T^{-j} \{\varphi^{(n)} \leq k - j\} \in \mathcal{F}_j \vee \mathcal{F}_k \subset \mathcal{F}_k,$$

and thus $\{\varphi^{(n+1)} \leq k\}$ is \mathcal{F}_k -measurable. □

The Markov partitions α and α_φ can be refined by considering iterates of the transformation. For any stopping time φ and any $n \geq 1$, we define:

$$\alpha_\varphi^{(n)} := \bigvee_{k=0}^{n-1} T_\varphi^{-k} \alpha_\varphi.$$

With these notations, $\alpha_\varphi^{(n)} = \alpha_{\varphi^{(n)}}$. We also denote by $\alpha^{(n)} := \alpha_{\mathbf{1}}^{(n)}$ the partition generated by cylinders of length n .

A.2 Stopping times and regularizing effect of \mathcal{L}_φ

To each stopping time φ is associated a transformation T_φ , and thus a transfer operator \mathcal{L}_φ defined by

$$\int_A \mathcal{L}_\varphi(f) \cdot g \, d\mu = \int_A f \cdot g \circ T_\varphi \, d\mu \quad \forall f \in \mathbb{L}^1(A, \mu), \quad \forall g \in \mathbb{L}^\infty(A, \mu).$$

The transformation T_φ in general does not preserve μ , thus in general $\mathcal{L}_\varphi(\mathbf{1}) \neq \mathbf{1}$. The operator \mathcal{L}_φ still acts quasi-compactly on the Banach space \mathcal{B} introduced in Definition 1.6. To make the statement more flexible, we introduce local Lipschitz seminorms:

Definition A.4 (Local Lipschitz seminorms). *Let (A, α, d, μ, T) be a Gibbs-Markov map and $f : A \rightarrow \mathbb{C}$. The function $D_\alpha f : A \rightarrow \mathbb{R}_+ \cup \{+\infty\}$ is defined by*

$$D_\alpha f(x) := \sup_{\substack{y, z \in a \\ y \neq z}} \frac{|f(y) - f(z)|}{d(y, z)} \quad \forall a \in \alpha, \quad \forall x \in a.$$

For instance, $|f|_{\mathcal{B}} = \|D_{\alpha^*} f\|_{\mathbb{L}^\infty(A, \mu)}$, and $D_{\alpha^*} f \geq D_\alpha f$ since α^* is coarser than α .

Proposition A.5.

Let (A, α, d, μ, T) be a Gibbs-Markov map. There exists a constant C such that, for any stopping time φ and any $n \geq 1$, for any $\underline{a} \in \sigma(\alpha_\varphi^{(n)})$, for any $f : A \rightarrow \mathbb{C}$,

$$\|\mathcal{L}_\varphi^n(f \mathbf{1}_{\underline{a}})\|_{\mathcal{B}} \leq C \left[\Lambda^{-\inf_{\underline{a}} \varphi^{(n)}} \int_{\underline{a}} D_{\alpha_\varphi^{(n)}} f \, d\mu + \int_{\underline{a}} |f| \, d\mu \right] \quad (\text{A.2})$$

Proof. Let us assume that $\underline{a} = [a_0, \dots, a_{k-1}]$ is a cylinder of length $k = \varphi^{(n)}(\underline{a})$. Then $\mathcal{L}_\varphi^n(f \mathbf{1}_{\underline{a}}) = \mathcal{L}^k(f \mathbf{1}_{\underline{a}})$. In addition, $\Lambda^{-k} \leq \Lambda^{-\inf_{\underline{a}} \varphi^{(n)}}$. With these observations in mind, the claim is given by [21, Lemme 1.1.13], with the refinement that the local Lipschitz seminorm can be taken on \underline{a} instead of a_0 .

In general, \underline{a} is a countable union of such cylinders, and the claim follows by countable additivity of μ . \square

Proposition A.5 yields a uniform Lasota-Yorke inequality for \mathcal{L}_φ for all stopping times φ :

Corollary A.6.

Let (A, α, d, μ, T) be a Gibbs-Markov map. There exists a constant C such that, for any stopping time φ and any $n \geq 1$, for any $f \in \mathcal{B}$,

$$\|\mathcal{L}_\varphi^n(f)\|_{\mathcal{B}} \leq C \left[\Lambda^{-n} \|f\|_{\mathcal{B}} + \|f\|_{\mathbb{L}^1(A, \mu)} \right].$$

Proof. We apply Proposition A.5 with $\underline{a} = A$. The partition $\alpha_\varphi^{(n)}$ is finer than α , which is itself finer than α^* , whence $D_{\alpha_\varphi^{(n)}} f \leq D_{\alpha^*} f$ and

$$\int_A D_{\alpha_\varphi^{(n)}} f \, d\mu \leq \int_A D_{\alpha^*} f \, d\mu \leq \|D_{\alpha^*} f\|_{\mathbb{L}^\infty(A, \mu)} = |f|_{\mathcal{B}} \leq \|f\|_{\mathcal{B}}.$$

Finally, $\inf_A \varphi \geq 1$ so $\inf_A \varphi^{(n)} \geq n$. \square

In particular, $\rho_{\text{ess}}(\mathcal{L}_\varphi \curvearrowright \mathcal{B}) \leq \Lambda^{-1}$, and the usual arguments imply the existence of finitely many absolutely continuous invariant probability measures for T_φ . Another application of Proposition A.5 yields

Corollary A.7.

Let (A, α, d, μ, T) be a Gibbs-Markov map. There exists a constant C such that, for any stopping time φ and any $n \geq 1$, for any $\underline{a} \in \alpha_\varphi^{(n)}$ and $f \in \mathcal{B}$,

$$\|\mathcal{L}_\varphi^n(f\mathbf{1}_{\underline{a}})\|_{\mathcal{B}} \leq C\mu(\underline{a}) \|f\|_{\mathcal{B}}. \tag{A.3}$$

Proof. We apply Proposition A.5. The same argument as in the proof of Corollary A.6 yields

$$\begin{aligned} \|\mathcal{L}_\varphi^n(f\mathbf{1}_{\underline{a}})\|_{\mathcal{B}} &\leq C \left[\Lambda^{-n} \int_{\underline{a}} D_{\alpha_\varphi^{(n)}} f \, d\mu + \int_{\underline{a}} |f| \, d\mu \right] \\ &\leq C \left[\Lambda^{-n} \mu(\underline{a}) \|D_{\alpha^*} f\|_{\mathbb{L}^\infty(A, \mu)} + \mu(\underline{a}) \|f\|_{\mathbb{L}^\infty(A, \mu)} \right] \\ &\leq C\mu(\underline{a}) \|f\|_{\mathcal{B}}, \end{aligned}$$

with the same constant C . □

A.3 Induced Gibbs-Markov maps

Let (A, α, d, μ, T) be a Gibbs-Markov map, and $F : A \rightarrow \mathbb{Z}^d$ be constant on the elements of α . Let $([\mathbb{Z}^d], \tilde{\mu}, \tilde{T})$ be the associated \mathbb{Z}^d -extension, which we assume is recurrent. Let $\Sigma \subset \mathbb{Z}^d$ be non-empty and finite. We want to find a good Banach space on which the transfer operator associated with the induced system $([\Sigma], \mu_{[\Sigma]}, T_{[\Sigma]})$ acts. A natural candidate is the space $\mathcal{B}_{[\Sigma]}$ defined by Equation (1.5).

By adapting [40, Subsection 4.2.1], it is also possible to endow $([\Sigma], \mu_{[\Sigma]}, T_{[\Sigma]})$ with a Gibbs-Markov structure, which would then yield their own spaces of Lipschitz functions. However, these spaces are much too large, and their Lipschitz norm would depend on $[\Sigma]$. To keep some of our estimates uniform, we do not follow this line. Instead, we adapt the previous results on Gibbs-Markov maps to the specific case where the stopping time φ comes from an induction process applied to $([\mathbb{Z}^d], \tilde{\mu}, \tilde{T})$.

Since $([\mathbb{Z}^d], \tilde{\mu}, \tilde{T})$ is recurrent and measure-preserving, the system $([\Sigma], \mu_{[\Sigma]}, T_{[\Sigma]})$ is well-defined and measure-preserving.

Proposition A.8.

Let $([\mathbb{Z}^d], \tilde{\mu}, \tilde{T})$ be a recurrent Markov \mathbb{Z}^d -extension of a Gibbs-Markov map (A, α, d, μ, T) . Let $\Sigma \subset \mathbb{Z}^d$ be non-empty and finite. Then:

$$\begin{aligned} \rho(\mathcal{L}_{[\Sigma]} \curvearrowright \mathcal{B}_{[\Sigma]}) &= 1, \\ \rho_{\text{ess}}(\mathcal{L}_{[\Sigma]} \curvearrowright \mathcal{B}_{[\Sigma]}) &\leq \Lambda^{-1}, \end{aligned}$$

where $\Lambda > 1$ is any expansion constant for (A, α, d, μ, T) .

Proof. The extension $([\mathbb{Z}^d], \tilde{\mu}, \tilde{T})$ is Markov, so by definition the jump function F is constant on elements of the partition α . Hence, for all $p \in \Sigma$ and $n \geq 1$, we have an almost surely finite stopping time

$$\varphi_{p, \Sigma, n}(x) := \inf \{k \geq 1 : \text{Card}\{0 < \ell \leq k : S_\ell F(x) \in \{q - p : q \in \Sigma\}\} = n\}.$$

This stopping time is designed so that, for all $x \in A$,

$$T_{[\Sigma]}^n(x, p) = (T_{\varphi_{p, \Sigma, n}}(x), p + S_{\varphi_{p, \Sigma, n}(x)} F(x)).$$

For all $p, q \in \Sigma$ and $n \geq 1$, let

$$A_{p, q, n} := \{x \in A : (x, p) \in T_{[\Sigma]}^{-n}([q])\},$$

which is $\sigma(\alpha_{\varphi_{p, \Sigma, n}})$ -measurable. Then, for all $p \in \Sigma$ and $n \geq 1$, for all $f \in \mathcal{B}_{[\Sigma]}$,

$$\mathcal{L}_{[\Sigma]}^n(f)(\cdot, p) = \sum_{q \in \Sigma} \mathcal{L}_{\varphi_{q, \Sigma, n}}(f(\cdot, q) \mathbf{1}_{A_{q, p, n}}).$$

By Proposition A.5, there exists a constant C depending only on the initial Gibbs-Markov map such that

$$\begin{aligned} \|\mathcal{L}_{[\Sigma]}^n(f)(\cdot, p)\|_{\mathcal{B}} &\leq \sum_{q \in \Sigma} \|\mathcal{L}_{\varphi_{q, \Sigma, n}}(f(\cdot, q) \mathbf{1}_{A_{q, p, n}})\|_{\mathcal{B}} \\ &\leq \sum_{q \in \Sigma} C \left[\Lambda^{-\inf_{A_{q, p, n}} \varphi_{q, \Sigma, n}} \int_{A_{q, p, n}} D_{\alpha^*} f(\cdot, q) \, d\mu + \int_{A_{q, p, n}} |f|(\cdot, q) \, d\mu \right] \\ &\leq \sum_{q \in \Sigma} C \left[\Lambda^{-n} \mu(A_{q, p, n}) \|f\|_{\mathcal{B}_{[\Sigma]}} + \int_{A_{q, p, n}} |f|(\cdot, q) \, d\mu \right] \\ &= C \left[\Lambda^{-n} \|f\|_{\mathcal{B}_{[\Sigma]}} + \sum_{q \in \Sigma} \int_{A_{q, p, n}} |f|(\cdot, q) \, d\mu \right]. \end{aligned}$$

Taking the supremum over $p \in \Sigma$ yields

$$\begin{aligned} \|\mathcal{L}_{[\Sigma]}^n(f)\|_{\mathcal{B}_{[\Sigma]}} &\leq C \left[\Lambda^{-n} \|f\|_{\mathcal{B}_{[\Sigma]}} + \sum_{p, q \in \Sigma} \int_{A_{q, p, n}} |f|(\cdot, q) \, d\mu \right] \\ &\leq C \left[\Lambda^{-n} \|f\|_{\mathcal{B}_{[\Sigma]}} + |\Sigma| \int_{[\Sigma]} |f|(\cdot, q) \, d\mu_{[\Sigma]} \right]. \end{aligned}$$

The bound on the essential spectral radius $\rho_{\text{ess}}(\mathcal{L}_{[\Sigma]} \curvearrowright \mathcal{B}_{[\Sigma]})$ comes from Hennion's theorem [25]. The spectral radius is at least 1 since $\mathcal{L}_{[\Sigma]}(\mathbf{1}) = \mathbf{1}$, and at most 1 because of the Lasota-Yorke inequality and the fact that the spectrum of $\mathcal{L}_{[\Sigma]}$ outside $\overline{B}(0, \Lambda^{-1})$ is made of eigenvalues of $\mathcal{L}_{[\Sigma]}$. \square

If in addition $([\Sigma], \mu_{[\Sigma]}, T_{[\Sigma]})$ is mixing, then the operator $\mathcal{L}_{[\Sigma]} \curvearrowright \mathcal{B}_{[\Sigma], 0}$ decays at exponential speed; otherwise, the induced system $([\Sigma], \mu_{[\Sigma]}, T_{[\Sigma]})$ has a period, which we need to take into account. The proofs of the following theorems are classical, albeit lengthy; we refer the reader, for instance, to [21, Corollaire 1.1.18] and [21, Corollaire 1.1.19].

Corollary A.9.

Let $([\mathbb{Z}^d], \tilde{\mu}, \tilde{T})$ be an ergodic and recurrent Markov \mathbb{Z}^d -extension of a Gibbs-Markov map with data (A, α, d, μ, T) . Assume furthermore that $([0], \mu, T_{[0]})$ is mixing.

Then there exist constants $C > 0$ and $\rho \in (0, 1)$ such that, for all $f \in \mathcal{B}_0$ and $n \geq 0$,

$$\|\mathcal{L}_{[0]}^n f\|_{\mathcal{B}} \leq C \rho^n \|f\|_{\mathcal{B}}. \tag{A.4}$$

Corollary A.10.

Let $([\mathbb{Z}^d], \tilde{\mu}, \tilde{T})$ be an ergodic and recurrent Markov \mathbb{Z}^d -extension of a Gibbs-Markov map with data (A, α, d, μ, T) . Let $M \geq 1$ be such that $\text{Sp}(\mathcal{L}_{[0]} \curvearrowright \mathcal{B}) \cap \mathbb{S}_1$ is the group of M th roots of the unit.

Then there exists a partition $A = \bigsqcup_{\ell \in \mathbb{Z}/M\mathbb{Z}} A_\ell$ such that each A_ℓ is $\sigma(\alpha^*)$ -measurable and $T_{[0]}(A_\ell) \subset A_{\ell+1}$ for all ℓ . Setting $\mathcal{B}_\ell := \{f \in \mathcal{B} : \text{Supp}(f) \subset A_\ell\}$,

$$\mathcal{B} = \bigoplus_{\ell \in \mathbb{Z}/M\mathbb{Z}} \mathcal{B}_\ell,$$

and each restriction $\mathcal{L}_{[0]} : \mathcal{B}_\ell \rightarrow \mathcal{B}_{\ell+1}$ is continuous. In addition, $T_{[0]}^M : A_\ell \rightarrow A_\ell$ is mixing for all ℓ .

Finally, there exist constants $C > 0$ and $\rho \in (0, 1)$ such that, for all $f \in \mathcal{B}$ and $n \geq 0$,

$$\left\| \frac{1}{M} \sum_{\ell=0}^{M-1} \mathcal{L}_{[0]}^{n+\ell} f - \int_{[0]} f \, d\mu \right\|_{\mathcal{B}} \leq C \rho^n \|f\|_{\mathcal{B}}. \quad (\text{A.5})$$

We may also adapt Proposition A.5 to get that $\mathcal{L}_{[\Sigma]}$ maps a much larger Banach space into $\mathcal{B}_{[\Sigma]}$. As in Section 5, let $\alpha_{p,\Sigma}$ be the partition associated with the stopping time

$$\varphi_{p,\Sigma}(x) := \inf\{n \geq 1 : S_n F(x) \in \{q - p : q \in \Sigma\}\}.$$

Set $\alpha_{[\Sigma]} := \{a \times \{p\} : a \in \alpha_{p,\Sigma}, p \in \Sigma\}$. We define a seminorm

$$|f|_{\text{Lip}^1([\Sigma])} := \sum_{a \times \{p\} \in \alpha_{[\Sigma]}} \mu(a) |f(\cdot, p)|_{\text{Lip}(a)},$$

and a norm $\|f\|_{\text{Lip}^1([\Sigma])} := |f|_{\text{Lip}^1([\Sigma])} + \|f\|_{\mathbb{L}^1([\Sigma], \mu_{[\Sigma]})}$. Then we get:

Proposition A.11.

Let $([\mathbb{Z}^d], \tilde{\mu}, \tilde{T})$ be a recurrent Markov \mathbb{Z}^d -extension of a Gibbs-Markov map (A, α, d, μ, T) . Let $\Sigma \subset \mathbb{Z}^d$ be non-empty and finite. Then $\mathcal{L}_{[\Sigma]} : \text{Lip}^1([\Sigma]) \rightarrow \mathcal{B}_{[\Sigma]}$ is continuous.

Proof. We use the same notation as in the proof of Proposition A.8 with $n = 1$. For all $p, q \in \Sigma$, for all $a \times \{p\} \in \alpha_{[\Sigma]}$, for all $f \in \text{Lip}^1([\Sigma])$, by Proposition A.5,

$$\begin{aligned} \|\mathcal{L}_{[\Sigma]}(f)(\cdot, p)\|_{\mathcal{B}} &\leq \sum_{q \in \Sigma} \sum_{\substack{a \times \{q\} \in \alpha_{[\Sigma]} \\ a \subset A_{q,p,1}}} \|\mathcal{L}_{\varphi_{q,\Sigma,1}}(f(\cdot, q) \mathbf{1}_a)\|_{\mathcal{B}} \\ &\leq \sum_{q \in \Sigma} \sum_{\substack{a \times \{q\} \in \alpha_{[\Sigma]} \\ a \subset A_{q,p,1}}} C \left[\Lambda^{-1} \mu(a) |f|_{\text{Lip}(a)} + \int_a |f|(\cdot, q) \, d\mu \right] \\ &= C \Lambda^{-1} |f|_{\text{Lip}^1([\Sigma])} + C |\Sigma| \|f\|_{\mathbb{L}^1([\Sigma], \mu_{[\Sigma]})} \\ &\leq C |\Sigma| \|f\|_{\text{Lip}^1([\Sigma])}. \quad \square \end{aligned}$$

References

- [1] J. Aaronson, *An introduction to infinite ergodic theory*, American Mathematical Society, 1997.

- [2] J. Aaronson and M. Denker. *Characteristic functions of random variables attracted to 1-stable laws*, Annals of Probability, **26** (1998), no. 1, 399–415.
- [3] J. Aaronson and M. Denker. *The Poincaré series of $\mathbb{C} \setminus \mathbb{Z}$* , Ergodic Theory and Dynamical Systems, **19** (1999), no. 1, 1–20.
- [4] J. Aaronson and M. Denker, *Local limit theorems for partial sums of stationary sequences generated by Gibbs-Markov maps*, Stochastics and Dynamics, **1** (2001), 193–237.
- [5] T.M. Apostol, *Mathematical analysis*, Second edition. Addison-Wesley Publishing Co., Reading, Mass.-London-Don Mills, Ont., 1974.
- [6] P. Bálint, T. Gilbert, P. Nándori, D. Szász and I.P. Tóth, *On the limiting Markov process of energy exchanges in a rarely interacting ball-piston gas*, Journal of Statistical Physics, **166** (2017), no. 3-4, 903–925.
- [7] N.H. Bingham, C.M. Goldie et J.L. Teugels, *Regular variation*, Encyclopedia of Mathematics and its Applications, 1987.
- [8] P.M. Bleher, *Statistical properties of two-dimensional periodic Lorentz gas with infinite horizon*, Journal of Statistical Physics, vol. **66** (1992), no. 1, 315–373.
- [9] N. Chernov and D. Dolgopyat, *Brownian Brownian motion-I*, Memoirs of the AMS, vol. **198** (2009), no. 927.
- [10] N. Chernov and R. Markarian, *Chaotic billiards*, Mathematical Surveys and Monographs, **127**. American Mathematical Society, Providence, RI, 2006.
- [11] D.A. Darling and M. Kac, *On occupation times for Markoff processes*, Transactions of the American Mathematical Society, **84** (1957), 444–458.
- [12] J. de Simoi and C. Liverani, *The martingale approach after Varadhan and Dolgopyat*, In "Hyperbolic Dynamics, Fluctuations and Large Deviations". Dolgopyat, Pesin, Pollicott, Stoyanov editors. Proceedings of Symposia in Pure Mathematics, **89** (2015), AMS.
- [13] J. de Simoi and C. Liverani, *Limit Theorems for fast-slow partially hyperbolic systems*, Inventiones Mathematicæ, **213** (2018), 811–1016.
- [14] V. Delecroix, P. Hubert and S. Lelièvre, *Diffusion for the periodic wind-tree model*, Annales Scientifiques de l'École Normale Supérieure. Quatrième série, **47** (2014), no. 6, 1085–1110.
- [15] D. Dolgopyat, *Averaging and invariant measures*, Moscow Mathematical Journal, **5** (2005), 537–576.
- [16] D. Dolgopyat and P. Nándori, *On mixing and the local central limit theorem for hyperbolic flows*, Ergodic Theory and Dynamical Systems, **40** (2020), no. 1, 142–174.
- [17] D. Dolgopyat and P. Wright, *The diffusion coefficient for piecewise expanding maps of the interval with metastable states*, Stochastics and Dynamics, **12** (2012), no. 1.
- [18] W. Feller, *An introduction to probability theory and its applications. Vol II*. John Wiley & Sons, Inc., New York-London-Sydney, 1966.

- [19] C. Fougeron, *Diffusion rate of windtree models and Lyapunov exponents*, Bulletin de la Société Mathématique de France, **148** (2020), no. 1, 25–49.
- [20] M.I. Gordin, *The central limit theorem for stationary processes*, Doklady Akademii Nauk SSSR, **188** (1969), 739–741 (in Russian).
- [21] S. Gouëzel, *Vitesse de décorrélation et théorèmes limites pour les applications non uniformément dilatantes*, PhD thesis, Université Paris XI, 2008 version (in French).
- [22] Y. Guivarc’h and J. Hardy, *Théorèmes limites pour une classe de chaînes de Markov et applications aux difféomorphismes d’Anosov*, Annales de l’Institut Henri Poincaré, **24** (1988), no. 1, 73–98 (in French).
- [23] B. Hall, *Lie groups, Lie algebras, and representations. An elementary introduction*. Second edition. Graduate Texts in Mathematics, **222**. Springer, Cham, 2015.
- [24] P.R. Halmos, *Lectures on ergodic theory*, Publications of the Mathematical Society of Japan, no. 3, The Mathematical Society of Japan, 1956.
- [25] H. Hennion, *Sur un théorème spectral et son application aux noyaux lipchitziens*, Proceedings of the American Mathematical Society, **118** (1993), 627–639.
- [26] M. Hirata, *Poisson law for Axiom A diffeomorphisms*, Ergodic Theory and Dynamical Systems, **13** (1993), no. 3, 533–556.
- [27] J. Karamata, *Sur un mode de croissance régulière. Théorèmes fondamentaux*, Bulletin de la Société Mathématique de France, **61** (1933), 55–62 (in French).
- [28] T. Kato, *Perturbation theory for linear operators*, reprint of the 1980 edition, Classics in Mathematics, Springer-Verlag, Berlin (1995).
- [29] G. Keller and C. Liverani, *Rare events, escape rates and quasistationarity: Some exact formulae*, Journal of Statistical Physics, **135** (2009), 519–534.
- [30] G. Keller and C. Liverani, *Map lattices coupled by collisions*, Communications in Mathematical Physics, **291** (2009), no. 2, 591–597.
- [31] A. Krámli and D. Szász, *Random walks with internal degrees of freedom. I. Local limit theorems*, Zeitschrift für Wahrscheinlichkeitstheorie und Verwandte Gebiete, **63** (1983), no. 1, 85–95.
- [32] A. Krámli and D. Szász, *Random walks with internal degrees of freedom. II. First-hitting probabilities*, Zeitschrift für Wahrscheinlichkeitstheorie und Verwandte Gebiete, **68** (1984), no. 1, 53–64.
- [33] A. Krámli, N. Simányi and D. Szász, *Random walks with internal degrees of freedom. III. Stationary probabilities*, Probability Theory and Related Fields, **72** (1986), no. 4, 603–617.
- [34] A. Lasota and J.A. Yorke, *On the existence of invariant measures for piecewise monotonic transformations*, Transactions of the American Mathematical Society, **186** (1973), 481–488.

- [35] D.A. Levin, Y. Peres and E.L. Wilmer, *Markov chains and mixing times*. American Mathematical Society, 2006.
- [36] S.V. Nagaev, *Some limit theorems for stationary Markov chains*, Theory of Probability and its Applications, **11** (1957), no. 4, 378–406.
- [37] S.V. Nagaev, *More exact statements of limit theorems for homogeneous Markov chains*, Teoriya Veroyatnostei i ee Primeneniya, **6** (1961), 67–87 (in Russian).
- [38] S. Orey and S. Pelikan, *Large deviation principles for stationary processes*, The Annals of Probability, **16** (1988), no. 4, 1481–1495.
- [39] S. Orey and S. Pelikan, *Deviations of trajectory averages and the defect in Pesin’s formula for Anosov diffeomorphisms*, Transactions of the American Mathematical Society, **315** (1989), no. 2, 741–753.
- [40] F. Pene and D. Thomine, *Potential kernel, hitting probabilities and distributional asymptotics*, to appear in Ergodic Theory and Dynamical Systems.
- [41] F. Pene and D. Thomine, *Probabilistic potential theory and induction of dynamical systems*, to appear in the Annales de l’Institut Henri Poincaré.
- [42] B. Pitskel’, *Poisson law for Markov chains*, Ergodic Theory and Dynamical Systems, **11** (1991), no. 3, 501–513.
- [43] M. Pollicott and R. Sharp, *Rates of recurrence for \mathbb{Z}^q and \mathbb{R}^q extensions of subshifts of finite type*, Journal of the London Mathematical Society. Second Series, **49** (1994), no. 2, 401–416.
- [44] M. Pollicott and R. Sharp, *Orbit counting for some discrete groups acting on simply connected manifolds with negative curvature*, Inventiones Mathematicae, **117** (1994), no. 2, 275–302.
- [45] D. Revuz, *Markov chains*, North-Holland Mathematical Library, Vol. 11. North-Holland Publishing Co., Amsterdam-Oxford; American Elsevier Publishing Co., Inc., New York, 1975.
- [46] M. Rychlik, *Bounded variation and invariant measures*, Studia Mathematica, **76** (1983), 69–80.
- [47] Ya.G. Sinai, *The central limit theorem for geodesic flows on manifolds of constant negative curvature*, Doklady Akademii Nauk SSSR, **133** (1960), 1303–1306 (in Russian).
- [48] D. Szász and T. Varjú, *Local limit theorem for the Lorentz process and its recurrence in the plane*, Ergodic Theory and Dynamical Systems, **24** (2004), no. 1, 257–278.
- [49] D. Szász and T. Varjú, *Limit laws and recurrence for the planar Lorentz process with infinite horizon*, Journal of Statistical Physics, **129** (2007), 59–80.
- [50] H. Tanaka, *Perturbed finite-state Markov systems with holes and Perron complements of Ruelle operators*, Israel Journal of Mathematics, **236** (2020), no. 1, 91–131.

- [51] D. Thomine, *Variations on a central limit theorem in infinite ergodic theory*, Ergodic Theory and Dynamical Systems, **35** (2015), no. 5, 1610–1657.
- [52] D. Thomine, *Sinai billiard maps with Ruelle resonances*, Nonlinearity, **33** (2020), no. 12, 6971–6984.
- [53] L.-S. Young, *Large deviations in dynamical systems*, Transactions of the American Mathematical Society, **318** (1990), no. 2, 525–543.
- [54] L.-S. Young, *Statistical properties of dynamical systems with some hyperbolicity*, Annals of Mathematics, Second Series, **147** (1998), no. 3, 585–650.