



**HAL**  
open science

# Total Cost Minimization of a High-Pressure Natural Gas Network

Firooz Tabkhi, Luc Pibouleau, Catherine Azzaro-Pantel, Serge Domenech

► **To cite this version:**

Firooz Tabkhi, Luc Pibouleau, Catherine Azzaro-Pantel, Serge Domenech. Total Cost Minimization of a High-Pressure Natural Gas Network. *Journal of Energy Resources Technology*, 2009, 131 (4), pp.043002-1. 10.1115/1.4000325 . hal-03474935

**HAL Id: hal-03474935**

**<https://hal.science/hal-03474935v1>**

Submitted on 10 Dec 2021

**HAL** is a multi-disciplinary open access archive for the deposit and dissemination of scientific research documents, whether they are published or not. The documents may come from teaching and research institutions in France or abroad, or from public or private research centers.

L'archive ouverte pluridisciplinaire **HAL**, est destinée au dépôt et à la diffusion de documents scientifiques de niveau recherche, publiés ou non, émanant des établissements d'enseignement et de recherche français ou étrangers, des laboratoires publics ou privés.



## Open Archive Toulouse Archive Ouverte (OATAO)

OATAO is an open access repository that collects the work of Toulouse researchers and makes it freely available over the web where possible.

This is an author-deposited version published in: <http://oatao.univ-toulouse.fr/>  
Eprints ID: 5003

**To link to this article:** DOI:10.1115/1.4000325  
<http://dx.doi.org/10.1115/1.4000325>

**To cite this version:**

Tabkhi, Firooz and Pibouleau, Luc and Azzaro-Pantel, Catherine and Domenech, Serge *Total Cost Minimization of a High-Pressure Natural Gas Network*. (2009) *Journal of Energy Resources Technology*, vol. 131 (n° 4). pp. 043002-1-043002-12. ISSN 0195-0738

Any correspondence concerning this service should be sent to the repository administrator: [staff-oatao@inp-toulouse.fr](mailto:staff-oatao@inp-toulouse.fr)

# Total Cost Minimization of a High-Pressure Natural Gas Network

F. Tabkhi

L. Pibouleau

C. Azzaro-Pantel<sup>1</sup>

e-mail: catherine.azzaropantel@ensiacet.fr

S. Domenech

Laboratoire de Génie Chimique,  
UMR CNRS 5503,  
ENSIACET/INPT/UPS,  
4 allée Emile Monso,  
BP 84234 31432,  
31106 Toulouse Cedex 4, France

*This paper deals with a high-pressure gas pipeline optimization, where the problem is to find the design properties of the pipelines and necessary compressor stations to satisfy customer requirements, using available supply gas and storage capacities. The considered objective function is the total annualized cost, including the investment and operating costs. The binary variables used to represent the flow direction of pipelines lead to a mixed integer nonlinear programming problem, solved by using the standard branch and bound solver in GAMS. The optimization strategy provides the main design parameters of the pipelines (diameters, pressures, and flow rates) and the characteristics of compressor stations (location, suction pressure, pressure ratio, station throughput, fuel consumption, and station power consumption) to satisfy customer requirements.*

[DOI: 10.1115/1.4000325]

*Keywords:* natural gas, network, pipeline, compressor, optimization, MINLP

## 1 Introduction

Natural gas (NG), viewed as a cleaner-burning alternative to coal and oil in terms of acidic and greenhouse gas pollution, is increasingly being used as an energy source and by most estimates, its global consumption will double by 2030 [1]. The transport of large quantities of NG is carried out by pipeline network systems across long distances. For example, the European natural gas system, which is very well developed, consists, *inter alia*, of  $1.4 \times 10^6$  km pipelines of which 145,000 km concern high-pressure transmission pipelines. As the gas flows through the network, pressure (and energy) is lost due to both friction between the gas and the pipe inner wall, and heat transfer between the gas and its environment. Typically, natural gas compressor stations are located at regular intervals along the pipeline to boost the pressure lost through the friction of the natural gas moving through the steel pipe. They consume a part of the transported gas, thus resulting in an important fuel consumption cost on the one hand, and in a significant contribution to CO<sub>2</sub> emissions, on the other hand. Two main issues are generally highlighted when considering pipeline transmission networks, *i.e.*, designing and operating a gas pipeline network. They generally involve technico-economic concerns, often based on capital cost minimization, throughput maximization, and fuel cost minimization.

Numerical simulations based on either steady state or transient models of the networks have been used to attempt to provide solutions to these problems. Following the development of the gas industry, gas pipeline networks have evolved over decades into very large and complex systems. A typical network today might consist of thousands of pipes, dozens of stations, and many other devices, such as valves and regulators. Inside each station, there can be several groups of compressor units of various vintages that were installed as the capacity of the system expanded. In that context, numerical simulation and optimization of gas pipeline can be of great help to design them, to predict their behavior, and to control their operation. Over the years, many researchers have attempted this issue.

The difficulties of such optimization problems arise from several aspects. First, compressor stations are very sophisticated entities themselves. They might consist of a few dozen compressor units with different configurations and characteristics. Each unit could be turned on or off, and its behavior is nonlinear. Second, the set of constraints that define feasible operating conditions in the compressors along with the constraints in the pipes constitutes a very complex system of nonlinear constraints. Third, the considered optimization problem often involves both continuous and integer variables and gives birth to a mixed integer nonlinear programming (MINLP) formulation. Moreover, the treatment of industrial-size problems may render the problem highly combinatorial.

The natural gas chain is generally constituted by various components as represented in Fig. 1. In this figure, the pressure regimes are just indicative and may differ from country to country.

The transport lying system between the natural gas deposits and the consumers is quite complex. After the gas has been extracted, so-called trunk lines are connected with pipeline compressor stations. The natural gas is then pumped into long distance pipelines called transmission lines and sent to the take-off stations for the consumers. From there, the gas is further transported to the control station of the regional distribution system. It then finally goes to industrial customers and households. A schematic view of a pipeline section is displayed in Fig. 2 with six compression stations, delivery, and supply points.

For transmission network problems considered in this study, compressor stations in a pipeline system can be subdivided into two classes: the originating stations, which are positioned at the inlet to the pipeline and are usually the most complex, and the booster stations, which are located along the pipeline to compensate for the pressure decrease due to friction and elevation losses. In principle, the longer the pipeline and the elevation of the terrain crossed, the more compressor horsepower is required to achieve the required delivery pressure at destination. However, under a fixed route and flow capacity, the number and size of booster stations can vary depending on circumstances and design. Although systems with fewer stations can be easier to operate, they have the disadvantage of introducing a need for high inlet pressures. Actual transmission systems represent a compromise between a very few powerful originating stations and a large number of small booster points.

<sup>1</sup>Corresponding author.

Contributed by the Petroleum Division of ASME for publication in the JOURNAL OF ENERGY RESOURCES TECHNOLOGY. ASSOC. EDITOR: Andrew K. Wojtanowicz.

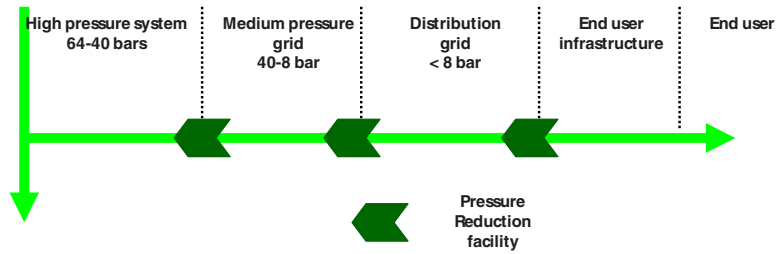

Fig. 1 Schematic view of the different parts of a natural gas delivery system

This paper deals with a high-pressure gas pipeline transmission network optimization, where the problem is to find the design properties of the pipelines and necessary compressor stations to satisfy customer requirements, using available supply gas and storage capacities. The considered objective function is the total annualized cost, including the investment and operating costs. The binary variables used to represent the flow direction of pipelines lead to a MINLP problem, solved by using the GAMS package. The approach is illustrated by an example taken from literature [2] inspired from the Belgian network. It comprises 20 nodes linked together with 20 arcs (see Fig. 3). The positions of nodes are selected such that they are consistent with their geographical location in the real network.

## 2 Previous Works

**2.1 Transmission Pipeline Modeling.** The qualitative presentation of the pipeline network and of its components highlights that engineering design and operation studies of pipeline network are involved with the optimization of the performance of the global system. The analysis of the dedicated literature shows that there is growing interest on the subject.

The optimization of the design of a pipeline to transmit fluids involves numerous variables, which include pipe diameter, pressure, temperature, line length, space between pumping or compressor stations, required inlet and delivery pressures, and delivery quantity. Each of these parameters influences the overall construction and operating cost in some degree.

This is as true for the design of a system from a clean sheet of paper (grass roots) as it is for the development and upgrading of an existing system; the only real difference between these two examples is the extent to which some of the variables are already fixed.

Because of the number of variables involved, the task of establishing the optimum can be quite difficult, and in order to ensure a robust solution, many options may have to be investigated.

The two main approaches that are classically encountered in gas network representation are numerical simulation and optimization.

The main purpose of simulation is to determine the actual behavior of a gas network under given conditions. Simulation basically answers the following question: What happens if we run our grid with given control variables and known boundary flows? Typical questions like finding a control regime, which achieves several target values, usually require a series of simulation runs by expert users who are familiar with the network. Two disadvantages of numerical simulation are found. First, finding an adequate regime may even take a large number of runs and, second, it cannot ensure that the solution achieved is optimal.

This explains mainly why the searching process must be substituted with more sophisticated algorithms. Yet, optimization generally works with simplified models, but it yields optimum results where limits or certain target values will be achieved automatically if they are defined as optimization problem constraints. There has been a great deal of work on the optimization approach to gas pipe distribution networks.

Since 20 years, there has been an interest on the optimization of gas pipe distribution networks. A one-dimensional compressible fluid flow equation is proposed in Ref. [3]. Lewandowski [4] implemented an object-oriented methodology for modeling a natural gas transmission network using a library of C++ classes, and Osiadacz [5] presented a dynamic optimization of high-pressure gas networks using hierarchical system theory. Surry et al. [6] formulated the optimization problem based on a multi-objective genetic algorithm. Mohitpour et al. [7] used a dynamic simulation approach for the design and optimization of pipeline

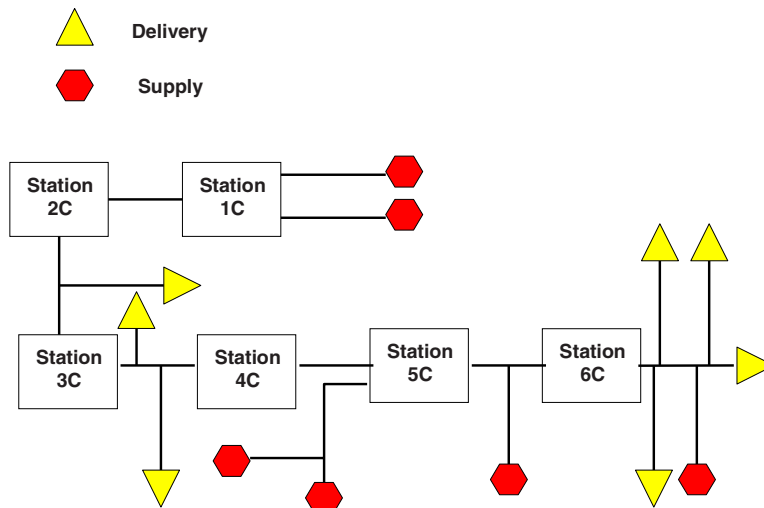

Fig. 2 Example of a pipeline section with six compression stations

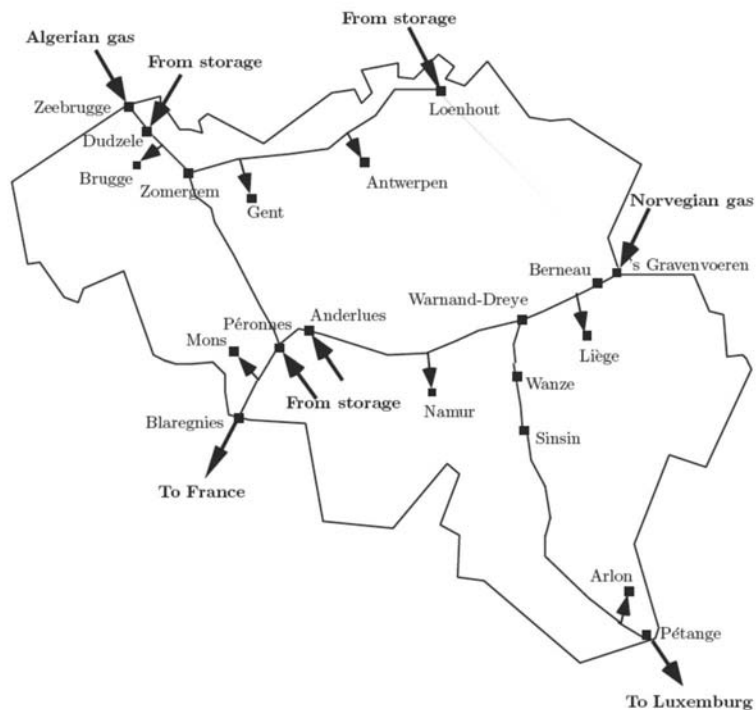
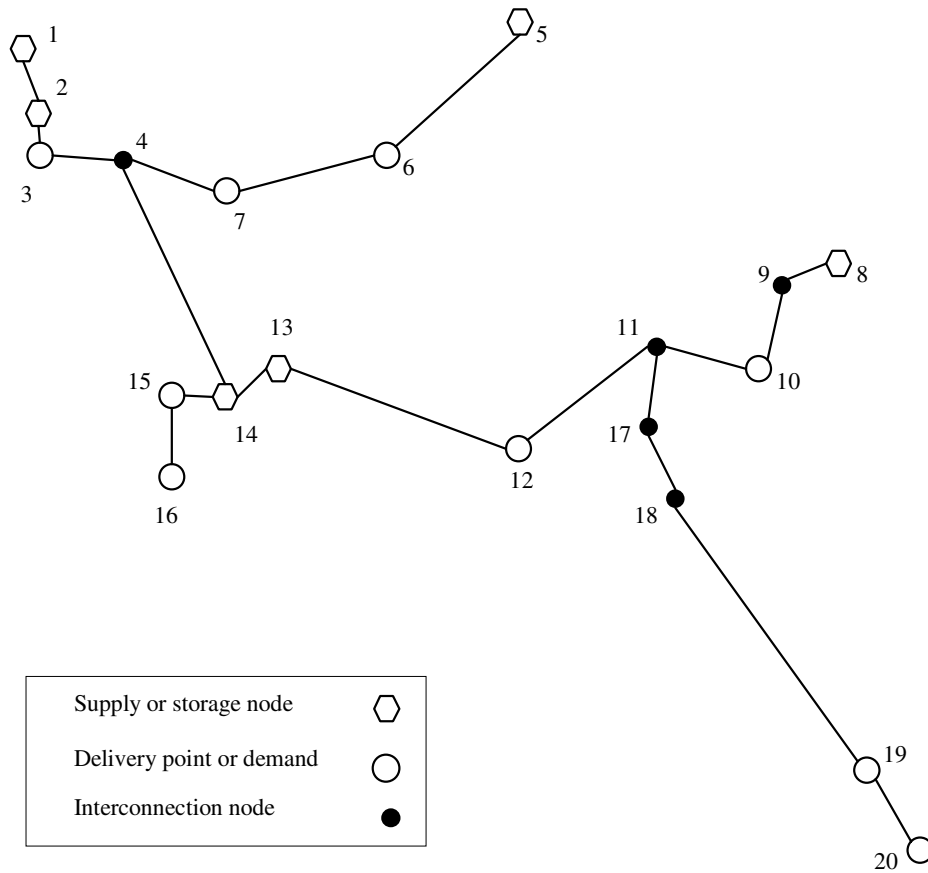

Fig. 3 Natural gas transmission network from Ref. [2]

transmission systems. Boyd et al. [8] studied steady-state gas pipeline networks by modeling the compressor stations. Costa et al. [9] developed a steady-state gas pipeline simulation. Sun et al. [10] based their modeling approach on a hybrid network using

minimum cost spanning tree. They also used a software support system [11], called the Gas pipeline operation advisor, for minimizing the overall operating costs, subject to a set of constraints such as the horsepower requirement, availability of individual

compressors, types of compressor, and the cycling of each compressor. A reduction technique for natural gas transmission network optimization problems was implemented by Rios-Mercado et al. [12]. Martinez-Romero et al. [13] used the software package “GAS NET.” A MINLP model for the problem of minimizing the fuel consumption in a pipeline network was implemented by Cobos-Zaleta and Rios-Mercado [14]. Mora and Ulieru [15] determined the pipeline operation configurations requiring the minimum amount of energy (e.g., fuel and power) needed to operate the equipment at compressor stations for given transportation requirements. Chauvelier-Alario et al. [16] developed CARPATHE, a simulation package GdF Suez, French Company for representing the behavior of multipressure networks and including functionalities for both network design and network operation. Optimization methods for planning reinforcement on gas transportation networks and for minimizing the investment cost of an existing gas transmission network were used by André et al. [17].

This literature analysis shows that there has been and continue to be a significant effort focused on the modeling of natural gas transmission networks. The objective of this work is to propose a framework able to embed formulations from design to operational purposes: this explains why only steady-state behavior of the gas flow is considered. The problem is to implement, for a given mathematical model of a pipeline network, a numerical method that meets the criteria of accuracy together with relatively small computation times.

**2.2 Optimization Techniques.** A great variety of applications, drawn from a wide range of investigation areas, can be formulated as complex optimization problems. It covers, for instance, the famous traveling man problem intensively studied [18] as well as frequencies allocation for radio-mobile networks [19], process network optimization [20], physicochemical equilibrium calculations [21], or hydrology computing [22]. In order to face these problems, a significant investigation effort has been carried out to develop efficient and robust optimization methods. At the beginning, this aim was concerned especially in the operational research and artificial intelligence areas. But the trend was subsequently followed by the process system engineering community, since this one provides a wide number of applications formulated as complex optimization problems. A typical reference is constituted by design problems related to heat or mass exchanger networks [23], supply chain design [24], multiproduct [25] or multipurpose [26], and batch plant design or retrofitting [27].

As a consequence, a great diversity of optimization methods was implemented to meet the industrial stakes and provide competitive results. But if they prove to be well-fitted to the particular case they purchase, these techniques’ performance cannot be constant whatever the treated problem is. Actually, method efficiency for a particular example is hardly predictable, and the only certainty we have is expressed by the *no free lunch* theory [28]: There is no method that outdoes all the other ones for any considered problem. This feature generates a common lack of explanation concerning the use of a method for the solution of a particular example, and usually, no relevant justification for its choice is given a priori. Among the diversity of optimization techniques, two important classes have to be distinguished: deterministic methods and stochastic ones. Complete reviews are proposed in literature [29–31]. A thorough analysis of both classes was previously studied in Ref. [32] with the support of batch plant design problems.

The deterministic methods involve the verification of mathematical properties of the objective function and constraints, such as continuity or derivability. This working mode enables them to ensure to get an optimum, which is a great advantage. Among the deterministic class, the following ones stand out: the branch and bound methods [33–35], the generalized Bender decomposition [36] and the outer approximation algorithms [37], the extended cutting plane method [38], and disjunctive programming methods [39]. Even though most of the above-mentioned methods keep

being at the academic level, some (commercial or free) computational codes are available: the standard branch and bound (SBB), BARON, DICOPT++, and LOGMIP solvers within the GAMS modeling environment [40], and MINLP\_BB [41] and aECP [42].

The second class, namely, metaheuristics or stochastic methods, is based on the evaluation of the objective function at different points of the search space. These points are chosen through the use of a set of heuristics, combined with generations of random numbers. Thus, metaheuristics cannot guarantee to obtain an optimum. They are divided into neighborhood techniques such as simulated annealing [43], tabu search [21], and evolutionary algorithms comprising genetic algorithms [44], evolutionary strategies [45], and evolutionary programming [46].

Since the number of constraints associated with the formulation of the problem related to the optimization of NG transmission networks may be important, the deterministic way is adopted in this study. To represent the deterministic class, solvers of the GAMS environment were chosen, since this optimization tool is widely used, and even stands as a reference for the solution of problems drawn from process engineering.

### 3 Model Formulation for Gas Pipeline Networks

**3.1 Gas Pipeline Hydraulics.** Due to operating problems, a gas transmission line is not normally designed to handle a two-phase flow. Exceptions lie, for example, in oil/gas wells, gathering systems, and separation units. The formulation presented here is only valid for a single phase flow. The pressure drop in a gas pipeline, i.e., the essential parameter to determine the required compression power for the transmission, is derived from the differential momentum balance.

Writing momentum balance, the equation of movement is obtained as [47]:

$$\frac{\partial p}{\partial x} + \frac{f}{2D} \frac{ZRT}{pMA^2} m^2 \pm g \frac{pM}{ZRT} \sin \alpha + \frac{R}{A^2 M} \frac{\partial}{\partial x} \left( \frac{ZT}{p} m^2 \right) + \frac{1}{A} \frac{\partial m}{\partial t} = 0 \quad (1)$$

where  $A$  is the cross area of the pipe ( $m^2$ ),  $R$  is the universal gas constant (8314 J/kmol K),  $T$  is temperature (K),  $m$  is the flow rate (kg/s), and  $\alpha$  is the angle between the pipe axis and the horizontal line.

By using Eqs. (3)–(9) and integrating Eq. (1), Tabkhi [48] showed that between points 1 and 2 of a pipe of length  $L$  (m) and internal diameter  $D$  (m), the steady-state pressure drop can be expressed in the following form:

$$(p_2^2 - p_1^2) - \frac{32m^2 ZRT}{\pi^2 D^4 M} \ln \left( \frac{p_2}{p_1} \right) + \frac{16f}{\pi^2 D^5} \frac{ZRT}{M} m^2 L = 0 \quad (2)$$

In this equation the various terms are defined as follows.

Gas density and pressure are linked by the following equation containing the compressibility factor  $Z$ :

$$\rho = \frac{pM}{ZRT} \quad (3)$$

where the average molecular mass of gas  $M$  is calculated using a simple mixing rule involving the mole fractions  $y_i$ s and the molecular masses  $M_i$ s:

$$M = \sum M_i y_i \quad (4)$$

The compressibility factor  $Z$  is used to alter the ideal gas equation to account for the real gas behavior. Traditionally, the compressibility factor is calculated using an equation of state. Yet, for natural gas, it may be estimated from the empirical relationship proposed for simulation goals in literature [49]. For example, this factor can be expressed as a function of the critical properties of the gas mixture, average pressure of the pipe segment, and the temperature that have been considered as constant:

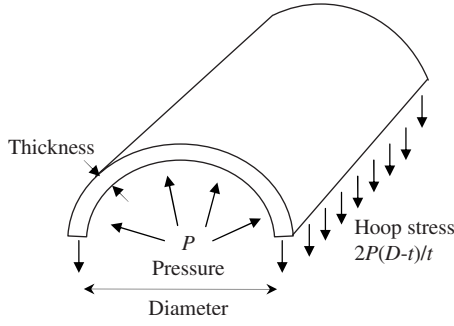

Fig. 4 Stress in pipeline subjected to internal pressure due to gas flow

$$Z = 1 + \left( 0.257 - 0.533 \frac{T_c}{T} \right) \frac{p_{ij}}{p_c} \quad (5)$$

The pseudocritical temperature of natural gas  $T_c$  and its pseudocritical pressure  $p_c$  can be calculated using an adequate mixing rule starting from the critical properties of the natural gas components. The critical point of a material is the point where the distinction between the liquid and vapor phases disappears. In this work, average pseudocritical properties of the gas are determined from the given mole fractions of its components by Kay's rule, which is a simple linear mixing rule shown in:

$$T_c = \sum T_{ci} y_i \quad (6)$$

$$p_c = \sum p_{ci} y_i \quad (7)$$

Average pressure  $p_{ij}$  can be calculated from two end pressures [49]

$$p_{ij} = \frac{2}{3} \left( p_i + p_j - \frac{p_i p_j}{p_i + p_j} \right) \quad (8)$$

Since the flow is considered fully developed here, which is the case concerned in gas pipelines, the friction factor  $f$  is estimated through the equation deduced by Prandtl-von Karman [50] in which the friction factor depends only on the relative roughness  $\varepsilon$  as follows:

$$f = \left( -2 \log \frac{\varepsilon/D}{3.71} \right)^{-2} \quad (9)$$

### 3.2 Fundamental Constraints

**3.2.1 MAOP.** The internal pressure in a pipe causes the pipe wall to be stressed, and if allowed to reach the yield strength of the pipe material, it could cause permanent deformation of the pipe and ultimate failure. In addition to the internal pressure due to gas flowing through the pipe, the pipe might also be subjected to external pressure, which can result from the weight of the soil above the pipe in a buried pipeline and also by the probable loads transmitted from vehicular traffic. Therefore, the necessary minimum wall thickness will be dictated by the internal pressure in a gas pipeline. The pressure at all points of the pipeline should be less than the maximum allowable operating pressure (MAOP), which is a design parameter in the pipeline engineering (see Fig. 4). This upper limit is calculated using Eq. (11) [48] as follows:

$$p < \text{MAOP} \quad (10)$$

$$\text{MAOP} = \text{SMYS} \frac{2t}{D-t} f_E f_T \quad (11)$$

The yield stress used in Eq. (11) is called the specified minimum yield strength (SMYS) of pipe material. SMYS is a mechanical property of the construction material of the gas pipeline. The fac-

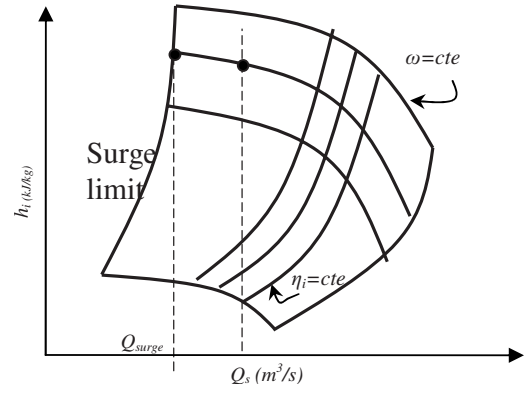

Fig. 5 A typical centrifugal compressor map

tor  $f_F$  has been named the design factor. This factor is usually 0.72 for cross-country or offshore gas pipelines, but can be as low as 0.4, depending on class location and type of construction. The class locations, in turn, depend on the population density in the vicinity of the pipeline. The seam joint factor  $f_E$  varies with the type of pipe material and joint type. Seam joint factors are between 1 and 0.6 for the most commonly used material types. The temperature factor  $f_T$  is equal to 1 for gas temperatures below 120°C before it reaches 0.867 at 230°C.

**3.2.2 Critical Velocities.** The increase in flow rate causes pressure drop increase. An important factor in the treatment of compressible fluid flow is the so-called critical flow. For a compressible flow, the increase in flow owing to the pressure drop increase is limited to the velocity of sound in the fluid, i.e., the critical velocity. Sonic or critical velocity is the maximum velocity which a compressible fluid can reach in a pipe. For trouble-free operation, velocities maintain under a half of sonic velocity. Sonic velocity in a gas  $c$  is calculated with a satisfactory approximation using Eq. (13). Here  $\kappa$  is the average isentropic exponent of the gas.  $C_p$  is the heat capacity at constant pressure in J/(kmol K).

$$v < c/2 \quad (12)$$

$$c = \sqrt{\frac{\kappa ZRT}{M}} \quad (13)$$

$$\kappa = \frac{\sum (C_{pi} y_i)}{M \sum (C_{pi} y_i) - R} \quad (14)$$

Increasing gas velocity in a pipeline can have a particular effect on the level of vibration and increase the noises too. Moreover, higher velocities in the course of a long period of time will cause the erosion of the inside surface of the tubes, elbows, and other joints. The upper limit of the velocity range should be such that erosion-corrosion cavitations or impingement attack will be minimal. The upper limit of the gas velocity for the design purposes is usually computed empirically with the following equation [51]. In pipeline design domain, the erosional velocity  $v_e$  falls always underneath the speed of sound in the gas:

$$v < v_e \quad (15)$$

$$v_e = 122 \sqrt{\frac{ZRT}{PM}} \quad (16)$$

**3.3 Compressor Characteristics.** As shown in Fig. 5, a centrifugal gas compressor is characterized by means of its delivered flow rate and its pressure ratio, and the ratio between suction side pressure of the compressor and its discharge pressure. The compression process in a centrifugal compressor can be well formulated using isentropic process aiming for calculating horsepower

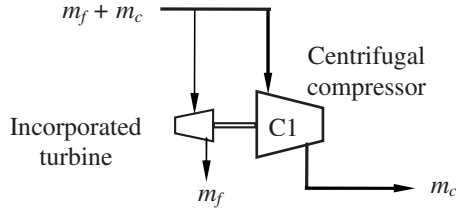

**Fig. 6 Representation of the centrifugal compressor and its incorporated turbine**

for a compressor station. The pressure ratio of a centrifugal compressor is usually linked with a specific term named “head” carried over from pump design nomenclature and expressed in meter even for compressors. The head developed by the compressor is defined as the amount of energy supplied to the gas per unit mass of gas.

The equation for power calculation can be expressed as follows:

$$P = \frac{m_c h_i}{i} \quad (17)$$

where  $m_c$  (kg/s) is the mass flow rate of compressed gas,  $h_i$  (m) is the compressor isentropic head, and  $\eta_i$  is the compressor isentropic efficiency.

This equation is obtained by considering compression adiabatic process that is a reasonable assumption because the heat transfer between gas and the outside is very low. For adiabatic compressor first the adiabatic efficiency is defined as:

$$\eta_i = \frac{P_{ideal}}{P} \quad (18)$$

As shown in the following equation, considering adiabatic compression, head is an index of the pressure ratio across the compressor. In this equation,  $p_d$  is the discharge pressure of the compressor and  $p_s$  is the suction pressure and  $\kappa$  is isentropic exponent and will be calculated using Eq. (14). The compressibility factor and the temperature here are considered at the suction side of the compressor [52]

$$h_i = \frac{Z_s R T_s}{M} \frac{\kappa}{\kappa - 1} \left[ \left( \frac{p_d}{p_s} \right)^{(\kappa-1)/\kappa} - 1 \right] \quad (19)$$

In this work, centrifugal compressors in the station are assumed to be driven by turbines whose supply energy is provided from a line of the gas derived from the pipeline passed through the station in order to be compressed as shown in Fig. 6. The flow rate of the consumed gas as fuel for the compression process in each compressor is obtained by dividing the required power for compression  $P$  by the mechanical efficiency  $\eta_m$ , driver efficiency  $\eta_d$ , and low heating value (LHV):

$$m_f = \frac{10^6 m_c h_i}{i \eta_m \eta_d \text{LHV}} \quad (20)$$

LHV represents the quantity of energy released by mass unity of the gas during complete combustion. It is considered at 25°C and 1 bar in kJ/kg and is calculated from the mass lower heating values,  $\text{LHV}_i$  of the molecules composing the gas:

$$\text{LHV} = \frac{\sum y_i M_i \text{LHV}_i}{\sum y_i M_i} \quad (21)$$

Applying standard polynomial curve-fit procedures for each compressor, the normalized head  $h_i/\kappa^2$  can thus be obtained under the form of the following equation [53]:

$$\frac{h_i}{\omega^2} = b_1 + b_2 \frac{Q_s}{\omega} + b_3 \left( \frac{Q_s}{\omega} \right)^2 \quad (22)$$

Also, contours of constant isentropic efficiency could be fitted in the polynomial form of second degree shown in:

$$i = b_4 + b_5 \frac{Q_s}{\omega} + b_6 \left( \frac{Q_s}{\omega} \right)^2 \quad (23)$$

The rotation speed  $\omega$  of all compressors is comprised between the lower and upper boundaries as represented below. To prevent from surge phenomenon, by considering surge margin  $\lambda_{\text{surge}}$ , the following constraint is introduced [54]:

$$\omega_l \leq \omega \leq \omega_u \quad (24)$$

$$\lambda_{\text{surge}} \leq \frac{Q_s - Q_{\text{surge}}}{Q_s} \quad (25)$$

There is a surge flow rate  $Q_{\text{surge}}$  corresponding to each compressor rotational speed [55]:

$$Q_{\text{surge}} = b_7 \left( \left( \frac{Z_s R T_s}{M p_s^2} \frac{\kappa - 1}{\kappa} h_{\text{surge}} + \left( \frac{Z_s R T_s}{p_s M} \right)^2 \right)^{\kappa/(\kappa-1)} - \left( \frac{Z_s R T_s}{p_s M} \right)^2 \right)^{1/2} \quad (26)$$

In this equation,  $h_{\text{surge}}$  is the surge head at a specified compressor speed and can be calculated using the following equation:

$$\frac{h_{\text{surge}}}{\omega^2} = b_1 + b_2 \frac{Q_{\text{surge}}}{\omega} + b_3 \left( \frac{Q_{\text{surge}}}{\omega} \right)^2 \quad (27)$$

Considering a fixed value for the surge pseudo-efficiency, it will be introduced as a parameter during optimization procedure. Equation (27) represents a nonlinear correlation between surge flow rate and rotational speed of the compressor.

**3.4 Incidence Matrices.** The different links between the elementary sections of a network can be defined using incidence matrices. So, all the relation between the variables of the system such as the material balances at steady state around the nodes of a pipeline network can be expressed under the very concise forms by using different types of incidence matrices such as the arc-node matrix [56]. In the model, each pipe, each compressor, and each fuel stream are represented by an arc. Consider a network with  $n$  nodes,  $l$  pipe arcs, and  $m$  compressor arcs. Therefore, there will be  $m$  fuel streams since for each compressor unit there is a stream that carries fuel to it. Because in a compressor, compression process is carried out, a compressor unit can be named an active arc. In this way, a pipe segment, in where the pressure decreases, may be called a passive arc. Let us note that the fuel streams have been considered as inert arcs regarding pressure change through them. A flow direction is assigned preliminarily to each pipe that can be or not coincide with the real flow direction of the gas that runs through the arc.

Let  $A$  be a matrix with the dimension of  $n \times (l+m)$ . Each of its elements,  $a_{ij}$  is given by:

$$a_{ij} = \begin{cases} 1 & \text{if arc } j \text{ comes out from node } i \\ -1 & \text{if arc } j \text{ goes into node } i \\ 0 & \text{otherwise} \end{cases}$$

$A$  is called the node-arc incidence matrix. Similarly, let  $B$  be another matrix with the dimension of  $l \times m$  whose element  $b_{ij}$  is defined below and is named the pipe-compressor incidence matrix:



**Table 1 Properties of the flowing gas through the network**

Gas component	CH <sub>4</sub>	C <sub>2</sub> H <sub>6</sub>	C <sub>3</sub> H <sub>8</sub>
Mole percent in gas	70	25	05
Molecular mass (g/mol)	16.04	30.07	44.10
Lower heating value at 15°C and 1 bar (MJ/m <sup>3</sup> )	37.706	66.067	93.936
Critical pressure (bar)	46.0	48.8	42.5
Critical temperature (K)	190.6	305.4	369.8
Heat capacity at constant pressure (J/mol K)	35.6635	52.848	74.916

$$b_{ij} = \begin{cases} 1 & \text{if pipe } i \text{ is connected to discharge node of compressor } j \\ -1 & \text{if pipe } i \text{ is connected to suction node of compressor } j \\ 0 & \text{otherwise} \end{cases}$$

The third defined matrix is the node-fuel incidence matrix, which describes the existing fuel stream derivations from a node, and it is called the compressor-fuel matrix. The dimension of this matrix is  $n \times m$  and its elements are defined as:

$$c_{ij} = \begin{cases} 1 & \text{if fuel stream } i \text{ be derived from node } j \\ 0 & \text{otherwise} \end{cases}$$

This matrix is also defined as previously, indicating which fuel stream belongs to which compressor. These incidence matrices are used to write the material balances around each node  $i$ , the flow rate of the consumed gas as fuel for the compression process in each compressor and the equation of movement. For example, the material balance around node  $i$  is expressed as Eq. (28). In this equation  $S_i$  represents the gas delivery or supply relative to this node. It is negative if the node is a delivery node and positive for a supply node where the gas is injected to the node.

$$\sum_{j \in \text{arcs}} a_{i,j} m_j + \sum_{j \in \text{compressors}} b_{i,j} m_{f_j} = S_i \quad (28)$$

**Table 2 Supply nodes' characteristics**

Supply node	Minimum value MMSCMD (kg/s)	Maximum value MMSCMD (kg/s)	Relative minimum pressure (bar)	Relative maximum pressure (bar)
1	08.870 (087.918)	11.594 (114.917)	00.0	77.0
8	20.344 (201.646)	22.012 (218.178)	50.0	66.2
Total	29.214 (289.564)	33.606 (333.095)		

Note: Relative pressure means absolute pressure added to atmospheric pressure, MMSCMD is the abbreviation of million standard cubic meters per day, and standard condition is taken at 25°C and 101,325 Pa.

**Table 3 Characteristics related to gas storage nodes**

Storage node	Maximum outflow MMSCMD (kg/s)	Relative minimum pressure (bar)	Relative maximum pressure (bar)
2	08.40 (083.259)	0.0	77.0
5	04.80 (047.577)	0.0	77.0
13	01.20 (011.894)	0.0	66.2
14	00.96 (009.515)	0.0	66.2
Total	15.36 (152.245)		

## 4 Numerical Example

**4.1 Network Structure.** The network was already presented in Fig. 3. The properties of flowing gas through the network are given in Table 1. There are two supply points 1 and 8 to satisfy the delivery requirements. The daily gas inputs at supply nodes 1 and 8 should not exceed their lower and upper bounds as shown in Table 2. The pressure of the gas supplied from node 1 is not limited inferiorly.

Available gas flows from the nodes where gas can be injected from storage tanks listed in Table 3. Storage tanks are located in nodes 2, 5, 13, and 14. Each storage facility has a maximum daily delivery capacity to gas network reported in Table 3. Daily gas demand at the nine delivery nodes is given in Table 4. It is assumed that the mass flow rates of gas demands are fixed. Pressure boundaries imposed to deliver gases should be respected. There is no lower limit on the pressure related to interconnection nodes. The upper limits on these pressures are given in Table 5.

In addition, the pressure at all nodes including interconnection nodes is limited superiorly with the MAOP of the arcs, which link them together. In Table 6, upstream and downstream nodes for all arcs of the network are defined. For each arc, at the beginning of the optimization procedure, it is assumed that gas flows from the upstream node to the downstream node. Then, the direction of the flow may be changed by the optimizer.

### 4.2 MINLP Problem

**4.2.1 General Formulation.** The goal is to search for the design properties of the pipelines and necessary compressor stations of the network presented in Fig. 3 to satisfy customer requirements using available supply gas and storage capacities. Yet, the

**Table 4 Daily gas demands and their pressure restrictions at delivery nodes**

Delivery node	Gas demand MMSCMD (kg/s)	Relative minimum pressure (bar)	Relative maximum pressure (bar)
3	03.918 (038.834)	30.0	80.0
6	04.034 (039.984)	30.0	80.0
7	05.256 (052.096)	30.0	80.0
10	06.365 (063.089)	30.0	66.2
12	02.120 (021.013)	00.0	66.2
15	06.848 (067.876)	00.0	66.2
16	15.616 (154.783)	50.0	66.2
19	00.222 (002.200)	00.0	66.2
20	01.919 (019.021)	25.0	66.2
Total	46.298 (458.896)		

**Table 5 Upper limits on the pressures of interconnection nodes**

Interconnection node	Relative maximum pressure (bar)	Interconnection node	Relative maximum pressure (bar)
4	80.0	17	66.2
9	66.2	18	63.0
11	66.2		

topology of the transmission network is set, i.e., the links between two nodes and the distance of the corresponding arc. However, a degree of freedom is introduced in the procedure: No gas flow direction is assigned a priori. The pipe diameters, as well as the power of required compressor stations, are decided via a MINLP algorithm within GAMS modeling environment. In addition, locations of necessary stations are also determined by the optimizer.

**4.2.2 Basic Design Conditions.** Design temperature is assumed equal to 281 K. All the other required properties of the components of natural gas are given in Table 1. For the used steel, SMYS, which is needed to determine pipeline MAOP, is supposed to be equal to 2000 bars that is within conventional typical values. Design factor, another parameter to calculate MAOP via Eq. (11) considered equal to 0.4, is a low enough and, consequently, safe value. Note that this factor depends on the class location of the pipeline, which depends also on the population density around it. Seam joint factor, which represents weld efficiency, is assumed to be equal to 1. The last factor present in Eq. (11), temperature derating factor, is considered equal to 1 since temperature is lower than 120°C. Absolute roughness of the interior surface of pipes is about 50 μm for steel pipes.

In order to compute fuel consumption, the total efficiency of compressor stations is considered equal to 25% for all stations. It is assumed that a compressor station is at least 1 km far from the neighboring nodes.

**4.2.3 Optimization Variables.** The continuous optimization variables are the pipeline diameters, the location of the compressor stations, as well as their horsepower, pressures, and gas flow rates at different nodes, pressure ratios, and gas consumption at compressor stations. In addition, a set of binary variables is used to define the flow directions in the pipelines. All of the continuous

**Table 6 Arc description**

Arc (upstream to downstream)	Length (km)
1-2	04.0
2-3	06.0
3-4	26.0
5-6	43.0
6-7	29.0
7-4	19.0
4-14	55.0
8-9	05.0
9-10	20.0
10-11	25.0
11-12	42.0
12-13	40.0
13-14	05.0
14-15	10.0
15-16	25.0
11-17	10.5
17-18	26.0
18-19	98.0
19-20	06.0

variables are positive except the flow rates of gas feeding or leaving the nodes of the network. This operating variable is negative for demand nodes, positive for supply or storage nodes, and zero for interconnection nodes.

There are basic design variables that are related to the equipment size including pipe diameters, the location of the compressor stations, as well as their horsepower. Note that for each pipeline, if a compressor station must be considered on a line, the diameter remains unchanged after the compressor station.

The other kind of continuous variables consists of operating variables such as pressures at different nodes, in addition to the gas flow rates feeding or leaving the nodes. None of the pressures subjected to nodes is fixed and all of them are bounded inferiorly and superiorly, so they must be decided during the optimization process.

Like as the mass flow rates through arcs, there are other operating variables such as pressure ratio at compressor stations, which are dependent variables that are computed when the previously nominated basic variables are fixed. Gas consumption at each station is another dependent variable. Because its amount is low enough compared with compressor throughput, the pipeline diameter will not be changed after a compressor station. Average gas velocity through a pipe, as well as its average compressibility factor, is also dependent on other variables such as the pressures at its end-point nodes.

Finally, a set of binary variables is defined to assign flow direction of pipelines. So a MINLP optimization problem will be encountered. If a binary variable would be equal to unity, flow direction will coincide with the one reported in Table 6, and if it would be equal to zero, gas flows in the direction opposite to that the one given in this table.

**4.2.4 Objective Function.** The goal in this optimization problem is to minimize the total annual cost. The objective function, total annualized cost as given in Eq. (29) [57], includes the sum of the investment cost depreciated over 10 years and the operating annual cost for all arcs:

$$ATC = \sum_{j \in \text{arcs}} (ICP_j + ICS_j + OCS_j) \quad (29)$$

In this equation ATC is the annualized total cost expressed in euros/year. The investment cost consists of that of the pipelines named ICP and that of the required compressor stations named ICS. The investment cost corresponding to the pipelines depends obviously on their lengths and diameters as shown in Eq. (30) where  $C_s$ ,  $d$ , and  $L$  are yearly unit pipe capital cost, pipe diameter, and pipe length, respectively.  $C_s$  is assumed 15,778 €/km m year) as follows:

$$ICP_j = (C_s d L)_j \quad (30)$$

The annualized investment cost of the compressor stations is divided into fixed and variable costs as shown in Eq. (31). The former term of the right-hand side is independent of station horsepower  $P$ , and takes into account installation costs, civil engineering, etc. The last term increases linearly WITH horsepower:

$$ICS_j = (C_f \text{sgn}(P) + C_b P)_j \quad (31)$$

The terms  $C_f$  and  $C_b$  in Eq. (31) are fixed and variable unit capital costs, respectively, and are supposed equal to 7410 €/year and 70 €/kW in this order [57]. If no compressor exists on an arc, its corresponding horsepower and so the term  $ICS_j$  are equal to zero. The sign function is introduced in the formulation to take into account that for arc  $j$ , if the compressor station horsepower  $P$  is equal to zero, then  $ICS$  is also equal to zero.

The only operating and maintenance cost that comes into account is due to the compressor stations. It is supposed that pipelines have no operating costs compared with compressor stations [57]. The yearly operating cost of a compressor station is also a

linear function of its horsepower, so it can be calculated according to Eq. (32) where unit operating cost  $C_o$  is assumed equal to 8.2 €/kW year [57] as follows:

$$OCS_j = (C_o P)_j \quad (32)$$

**4.2.5 Constraint Definition.** Calculation of MAOP using Eq. (11) for each pipeline requires its wall thickness that is obtained from the following equation in meter. This equation is obtained using the scheduled dimensions provided by ASME B36.19M standard that concerns stainless steel pipes:

$$t = 52 \times 10^{-3} d + 989 \times 10^{-7} \quad (33)$$

For each pipeline, using Eq. (2), continuity equation corresponding to the segment before compressor is written in the form of Eq. (34) by introducing the binary variable  $b$  that indicates the flow direction.

$$\frac{\pi^2 MD^5}{16ZRTfL_c} (2b-1)(P_i^2 - P_i^2) = [bm^2 + (1-b)(\dot{m} - \dot{m}_c)^2] \left[ 1 + \frac{2D}{fL_c} \ln\left(\frac{p_i}{p_1}\right) \right] \quad (34)$$

The friction factor is calculated using Eq. (9). Similarly, continuity equation for the section of pipeline after a compressor station is written in the form of:

$$\frac{\pi^2 MD^5}{16ZRTf(L-L_c)} (2b-1)(P_2^2 - P_2^2) = [(1-b)m^2 + b(\dot{m} - \dot{m}_c)^2] \left[ 1 + \frac{2D}{f(L-L_c)} \ln\left(\frac{p_2}{p_j}\right) \right] \quad (35)$$

Using Eq. (28), the material balance around node  $i$  can be written as Eq. (36). In this equation  $S_i$  represents the gas delivery or supply to this node. It is negative if the node is a delivery node, positive for a supply or storage node where the gas is injected to the gas network, and zero otherwise.

$$\sum_{k \in \text{arcs}} [a_{i,j} m_j (2b_j - 1) - m_{c,j} (a_{i,j} (2b_j - 1) - 1) / 2] = S_i \quad (36)$$

The existence of a compressor station on an arc is decided when pressure ratio is more than 1, its lower bound. Pressure ratio is obtained using following equation where  $p_1$  and  $p_2$  are compressor station end-point pressures. Note that if  $b=1$  then  $p_1$  and  $p_2$  are suction and discharge pressures, respectively, and if  $b=0$  vice versa:

$$\text{Ratio} = b \left( \frac{p_2}{p_1} \right) + (1-b) \left( \frac{p_1}{p_2} \right), \quad 1 \leq \text{ratio} \leq 2 \quad (37)$$

As mentioned, the pressure ratio is comprised between a lower bound that is obviously equal to one and its upper bound considered equal to two. This value is a classical one adopted in the dedicated literature.

The horsepower of a compressor station can be calculated starting from its pressure ratio and its throughput. Gas consumption rate in a station is obtained using Eq. (20). The gas consumption at each station depends linearly on its power consumption from Eqs. (17) and (20).

It has been imposed that if a compressor station must be considered on a line, it must work with a power greater than a lower value assumed here equal to  $P_- = 1000$  kW. This constraint is taken into account by declaring a special variable type called *semicontinuous* in the GAMS input file. Semicontinuous variables are those whose values, if nonzero, must be above a given minimum level. This can be expressed algebraically as the logic relation [40]:

**Table 7 Commercial pipe sizes**

Pipeline internal diameters in meter according to standard schedule No. 40				
0.154	0.178	0.203	0.227	0.254
0.279	0.305	0.336	0.387	0.438
0.489	0.540	0.590	0.641	0.692
0.743	0.794	0.844	0.895	

$$P = 0 \vee, \quad P_- \leq P \leq P^+, \quad P_- \neq 0 \quad (38)$$

Finally, the average gas velocity through pipelines is restricted by erosional velocity obtained following Eq. (16).

**4.2.6 Optimization Procedure.** Following the study of Ponsich [32], the code SBB of GAMS was chosen as a solution procedure. SBB is a GAMS solver based on a combination of the standard branch and bound method known from mixed integer linear programming (MILP) and some of the standard NLP solvers already supported by GAMS such as CONOPT and sparse nonlinear optimizer (SNOPT). SBB supports all the types of discrete variables including binary, integer, and some other specific ones [40].

The relaxed mixed integer nonlinear programming (RMINLP) model is initially solved using the starting point. A RMINLP model can contain both discrete variables and general nonlinear terms, but the discrete requirements are relaxed. In other words, the integer and binary variables can assume any values between their bounds; thus a RMINLP model will be just as a NLP problem. If all discrete variables in the RMINLP model are integer, SBB will return this solution as the optimal integer solution. Otherwise, the current solution is stored and the branch and bound procedure will start.

During the branch and bound process, the feasible region for the discrete variables is subdivided, and bounds on discrete variables are tightened to new integer values to cut off the current noninteger solutions. Each time a bound is tightened, a new tighter NLP submodel is solved starting from the optimal solution to the previous looser submodel. The objective function values from the NLP submodel are assumed to be lower bounds on the objective in the restricted feasible space (assuming minimization), even though the local optimum found by the NLP solver may not be a global optimum.

**4.2.7 First Optimization Case.** In this first case, pipeline diameters are considered as continuous variables. Then the resulted diameters are rounded up toward commercial sizes presented in Table 7 (commercial pipe sizes are based on the standard ASME B36.19M stainless steel pipe), following logic relationship (39). Finally, the pressure variables, as well as the flow rates and all other variables, are computed again performing another optimization process in GAMS where all the diameters are fixed.

$$d = \begin{cases} 0.154 & d \leq 0.154 \\ 0.178 & 0.154 < d \leq 0.178 \\ 0.203 & 0.178 < d \leq 0.203 \\ \vdots & \vdots \\ 0.844 & 0.794 < d \leq 0.844 \\ 0.895 & 0.844 < d \end{cases} \quad (39)$$

**4.2.8 Second Optimization Case.** Another way to proceed for considering only commercial sizes for pipe diameters is to code each diameter by an integer variable taking the values 1–19, each integer value being associated with a commercial size (for example, the value 1 represents the size 0.154 m, while the value 2 represents the size 0.178 m). Yet, in this case, the problem combinatorics explodes because the problem would involve, in addition to the 19 binary variables associated with the directions of

**Table 8 Optimum pipeline diameters**

Arc	Case 1, diameter (m)
1-2	0.489
2-3	0.743
3-4	0.692
5-6	0.305
6-7	0.154
7-4	0.305
4-14	0.590
8-9	0.844
9-10	0.844
10-11	0.692
11-12	0.641
12-13	0.590
13-14	0.590
14-15	0.844
15-16	0.743
11-17	0.305
17-18	0.279
18-19	0.336
19-20	0.305

Note: The wall thickness of the pipelines can be calculated following Eq. (33).

arcs, 19 additional integer variables, each one taking 19 values. The total number of possibilities is  $2^{19} \times 19^{19} = 1.03^{30}$ . So, in this case, the MINLP procedure either diverges or does not converge after several tens of CPU time.

**4.2.9 Results.** Because of the nonconvergence of case 2, only the results of case 1 are reported here. As already mentioned, after the post-treatment of the diameters, the pressure variables, as well as the flow rates and all the other variables, are computed again by solving another optimization problem in which the diameters are fixed, and the optimizer gives a total cost, discounted over 10 years, of  $4.024 \times 10^6$  euros. The computed diameters are shown in Table 8. The optimum pressures subjected to the nodes are shown in Table 9. The average compressibility factor in each pipe can be obtained for the optimum solutions by applying the results presented in this table, using Eqs. (5) and (8).

The mass flow rate of delivery gas for the demand nodes is fixed as a constraint shown in Table 4 but the optimum flow rate of injected gas to the network at the supply nodes or the storages

**Table 9 Pressure subjected to the nodes**

Node	Case 1, relative pressure (bar)
1	74.54
2	72.56
3	71.52
4	67.11
5	77.00
6	31.33
7	30.51
8	65.60
9	65.07
10	62.91
11	60.58
12	64.52
13	56.76
14	55.64
15	54.03
16	50.00
17	66.21
18	55.61
19	33.52
20	30.92

**Table 10 Mass flow rate of delivery gas or supply gas at the concerned nodes**

Node	Case 1, relative pressure (bar)
1	114.92
2	83.26
5	40.93
8	201.65
13	10.02
14	9.52

is calculated by the algorithm. They are shown in Table 10. The optimum mass flow rates across the different arcs are reported in Table 11. Using the information given in Tables 8, 9, and 11, optimum average gas velocity and erosional velocity for each arc can be calculated simply, following the equation linking the mass flow rate, the density, and the velocity of gas ( $m = (\pi/4)D^2\rho v$ ) and Eq. (16), respectively. For the pipelines on which a compressor station exists, the values presented in Table 11 express the gas flow rate before the station. So, there are compressor stations on the pipelines 10-11, 11-12, and 11-17. Their operating conditions are shown in Table 12.

The compressor stations with low-pressure ratio cannot be eliminated because their throughput is high enough to increase the station power consumption significantly.

The discharge pressure for each station can be easily obtained using Eq. (19). For each compressor station, the sum of the throughput and the fuel consumption is equal to its gas flow rate for each pipeline presented in Table 11. Obviously the mass flow rate of the gas through a pipeline after its compressor station is equal to the station throughput.

**Table 11 Gas mass flow rate through pipelines**

Arc	Case 1, flow rate (kg/s)
1-2	114.85
2-3	198.04
3-4	159.13
5-6	40.86
6-7	0.81
7-4	51.36
4-14	107.70
8-9	201.58
9-10	201.51
10-11	138.36
11-12	116.83
12-13	95.70
13-14	105.65
14-15	222.80
15-16	154.85
11-17	21.51
17-18	21.43
18-19	21.36
19-20	19.09

**Table 12 Optimum conditions related to necessary compressor stations**

Pipeline that requires a compressor station	10-11	11-12	11-17
Suction pressure (bar)	63.39	61.42	59.04
Pressure ratio	1.022	1.147	1.142
Station throughput (kg/s)	138.34	116.73	21.49
Fuel consumption (g/s)	18.5	101.8	18.5
Station power consumption (kW)	1000	5520	1000
Position from upstream node (km)	3.56	1.00	9.50

## 5 Conclusions

The objective of this work was to develop a general methodology for gas transmission pipeline modeling based on an optimization-oriented framework, able to embed formulations from design to operational purposes. For this purpose, steady-state behavior of the gas is considered and assumed in the momentum and mass balances.

Although various optimization techniques can be used, the choice of a deterministic one has guided the solution strategy, since it is generally recognized that this kind of methods is particularly well-fitted to take into account the important number of constraints that are likely to be involved in the problem formulation. An adequate solver, namely, SBB, within GAMS environment was selected since this optimization toolbox is often considered as a standard in process systems engineering.

A strategy to solve the optimal design of gas transmission network of a given topology is proposed. The approach is illustrated by an example taken from literature, inspired from the Belgian network. It comprises 20 nodes linked together with 20 arcs. The considered objective function is the total annualized cost, including the investment and operating costs. The optimization strategy provides the main design parameters of the pipelines (diameters, pressures, and flow rates) and the characteristics of compressor stations (location, suction pressure, pressure ratio, station throughput, fuel consumption, and station power consumption) to satisfy customer requirements.

## References

- [1] Riva, A., D'Angelosante, S., and Trebeschi, C., 2006, "Natural Gas and the Environmental Results of Lifecycle Assessment," *Energy*, **31**(1), pp. 138–148.
- [2] De Wolf, D., and Smeyers-Verbeke, Y., 2000, "The Gas Transmission Problem Solved by an Extension of the Simplex Algorithm," *Manage. Sci.*, **46**(11), pp. 1454–1465.
- [3] Tian, S., and Adewumi, M. A., 1994, "Development of Analytical Design Equation for Gas Pipelines," *SPE Prod. Facil.*, **9**(2), pp. 100–106.
- [4] Lewandowski, A., 1994, "Object-Oriented Modelling of the Natural Gas Pipeline Network," 26th Annual Meeting of Pipeline Simulation Interest Group, San Diego, CA, Oct. 13–14.
- [5] Osadacz, A. J., 1994, "Dynamic Optimization of High Pressure Gas Networks Using Hierarchical Systems Theory," 26th Annual Meeting of Pipeline Simulation Interest Group, San Diego, CA, Oct. 13–14.
- [6] Surry, P. D., Radcliffe, N. J., and Boyd, I. D., 1995, "A Multi-Objective Approach to Constrained Optimization of Gas Supply Networks: The COMOGA Method," *Lecture Notes in Computer Science, Evolutionary Computing*, Vol. 993, Springer, Berlin, pp. 166–180.
- [7] Mohitpour, M., Thompson, W., and Asante, B., 1996, "The Importance of Dynamic Simulation on the Design and Optimization of Pipeline Transmission Systems," *Proceedings of the ASME International Pipeline Conference*, Calgary, Canada, Vol. 2, pp. 1183–1188.
- [8] Boyd, E. A., Scott, L. R., and Wu, S. S., 1997, "Evaluating the Quality of Pipeline Optimization Algorithms," 29th Annual Meeting of Pipeline Simulation Interest Group, Tucson, AZ, Oct. 15–17.
- [9] Costa, A. L. H., de Medeiros, J. L., and Pessoa, F. L. P., 1998, "Steady-State Modelling and Simulation of Pipeline Networks for Compressible Fluids," *Braz. J. Chem. Eng.*, **15**(4), pp. 344–357.
- [10] Sun, C. K., Varanon, U., Chan, C. W., and Tontiwachwuthikul, P., 2000, "An Integrated Expert System/Operations Research Approach for Optimization of Natural Gas Pipeline Operations," *Eng. Applic. Artif. Intell.*, **13**(4), pp. 465–475.
- [11] Song, W., Huh, D., Lee, J., and Kwon, O., 1998, "Optimization of Pipeline Networks With a Hybrid MCST-CD Networking Model," *SPE Prod. Facil.*, **3426**(213), pp. 213–219.
- [12] Rios-Mercado, R. Z., Wu, S., Scott, L. R., and Boyd, E. A., 2002, "A Reduction Technique for Natural Gas Transmission Network Optimization Problems," *Ann. Operat. Res.*, **117**, pp. 217–234.
- [13] Martinez-Romero, N., Osorio-Peralta, O., and Santan-Vite, I., 2002, "Natural Gas Network Optimization and Sensibility Analysis," *Proceedings of the SPE International Petroleum Conference and Exhibition of Mexico*, pp. 357–370.
- [14] Cobos-Zaleta, D., and Rios-Mercado, R. Z., 2002, "A MINLP Model for a Minimizing Fuel Consumption on Natural Gas Pipeline Networks," *XI Latin-Ibero-American Conference on Operations Research*, Concepción, Chile, Oct. 27–31.
- [15] Mora, T., and Ulieru, M., 2005, "Minimization of Energy Use in Pipeline Operations—An Application to Natural Gas Transmission Systems," 31st Annual Conference of IEEE, Industrial Electronics Society (IECON), pp. 2190–2197.
- [16] Chauvelier-Alario, C., Mathieu, B., and Toussaint, C., 2006, "Decision Making Software for Gaz de France Distribution Network Operators: Carpathe," 23rd World Gas Conference, Amsterdam, Netherlands.
- [17] André, J., Bonnans, F., and Cornibert, L., 2006, "Planning Reinforcement on Gas Transportation Networks With Optimization Methods," *Process Operation Research Models and Methods in the Energy Sector Conference*, ORMES, Coimbra, Portugal.
- [18] Padberg, M., and Rinaldi, G., 1991, "A Branch-and-Cut Algorithm for the Resolution of Large Scale Symmetric Traveling Salesman Problems," *SIAM Rev.*, **33**(1), pp. 60–100.
- [19] Hao, J. K., and Dorne, R., 1996, "Study of Genetic Search for the Frequency Assignment Problem," *Lecture Notes in Computer Science*, Vol. 1063, Springer, Berlin, p. 333.
- [20] Lee, S., and Grossmann, I. E., 2003, "Global Optimization of Nonlinear Generalized Disjunctive Programming With Bilinear Equality Constraints: Applications to Process Networks," *Comput. Chem. Eng.*, **27**(11), pp. 1557–1575.
- [21] Teh, Y. S., and Rangaiah, G. P., 2003, "Tabu Search for Global Optimization of Continuous Functions With Application to Phase Equilibrium Calculations," *Comput. Chem. Eng.*, **27**(11), pp. 1665–1679.
- [22] Jain, A., Srinivasalu, S., and Bhattacharjya, R. K., 2005, "Determination of an Optimal Unit Pulse Response Function Using Real-Coded Genetic Algorithms," *J. Hydrol.*, **303**(1–4), pp. 199–214.
- [23] Zamora, M. Z., and Grossmann, I. E., 1998, "A Global MINLP Optimization Algorithm for the Synthesis of Heat Exchanger Networks With No Stream Splits," *Comput. Chem. Eng.*, **22**(3), pp. 367–384.
- [24] Guillén, G., Badell, M., Espuña, A., and Puigjaner, L., 2006, "Simultaneous Optimization of Process Operations and Financial Decisions to Enhance the Integrated Planning/Scheduling of Chemical Supply Chains," *Comput. Chem. Eng.*, **30**(3), pp. 421–436.
- [25] Ravemark, D. E., and Rippin, D. W. T., 1998, "Optimal Design of a Multi-Product Batch Plant," *Comput. Chem. Eng.*, **22**(1–2), pp. 177–183.
- [26] Dedieu, S., Pibouleau, L., Azzaro-Pantel, C., and Domenech, S., 2003, "Design and Retrofit of Multiobjective Batch Plants Via a Multicriteria Genetic Algorithm," *Comput. Chem. Eng.*, **27**(12), pp. 1723–1740.
- [27] Montagna, J. M., and Vecchietti, A. R., 2003, "Retrofit of Multiproduct Batch Plants Through Generalized Disjunctive Programming," *Math. Comput. Model.*, **38**(5–6), pp. 465–479.
- [28] Wolpert, D. H., and Macready, W. G., 1997, "No Free Lunch Theorems for Optimization," *IEEE Trans. Evol. Comput.*, **1**(1), pp. 67–82.
- [29] Hao, J. K., Galinier, P., and Habib, M., 1999, "Métaheuristiques pour l'Optimisation Combinatoire et l'Affectation Sous Contrainte," *Revue d'Intelligence Artificielle*, **13**(2), pp. 283–324.
- [30] Grossmann, I. E., 2002, "Review of Nonlinear Mixed-Integer and Disjunctive Programming Techniques," *Optim. Eng.*, **3**, pp. 227–252.
- [31] Biegler, L. T., and Grossmann, I. E., 2004, "Retrospective on Optimization," *Comput. Chem. Eng.*, **28**, pp. 1169–1192.
- [32] Ponsich, A., 2005, "Stratégies d'optimisation mixte en Génie des Procédés—Application à la conception d'ateliers discontinus," Ph.D. thesis, Institut National Polytechnique de Toulouse, Toulouse, France.
- [33] Gupta, A. K., and Ravindran, V., 1985, "Branch and Bound Experiments in Convex Nonlinear Integer Programming," *Manage. Sci.*, **31**(12), pp. 1533–1546.
- [34] Ryou, H. S., and Sahinidis, N. V., 1995, "Global Optimization of Nonconvex NLPs and MINLPs With Applications in Process Design," *Comput. Chem. Eng.*, **19**(5), pp. 551–566.
- [35] Smith, E. M. B., and Pantelides, C. C., 1999, "A Symbolic Reformulation/Spatial Branch-and-Bound Algorithm for the Global Optimization of Nonconvex MINLPs," *Comput. Chem. Eng.*, **23**(4–5), pp. 457–478.
- [36] Geoffrion, A. M., 1972, "Generalized Benders Decomposition," *J. Optim. Theory Appl.*, **10**(4), pp. 237–260.
- [37] Duran, M. A., and Grossmann, I. E., 1986, "An Outer-Approximation Algorithm for a Class of Mixed-Integer Nonlinear Programs," *Mathematical Programming: Series A and B*, **36**(3), pp. 307–339.
- [38] Westerlind, T., and Petterson, F., 1995, "An Extended Cutting Plane Method for Solving Convex MINLP Problems," *Comput. Chem. Eng.*, **19**(1), pp. S131–S136.
- [39] Raman, R., and Grossmann, I. E., 1994, "Modeling and Computational Techniques for Logic Based Integer Programming," *Comput. Chem. Eng.*, **18**(7), pp. 563–578.
- [40] Brooke, A., Kendrick, D., Meeraus, A., and Raman, R., 2004, *GAMS: A User's Guide*, GAMS Development Corporation, Washington, DC.
- [41] Leyffer, S., 1999, *User Manual for MINLP\_BB*, University of Dundee, Numerical Analysis Report No. NA/XXX.
- [42] Westerlind, T., and Lundqvist, K., 2003, *ALPHA-ECP*, version 5.04, an interactive MINLP-solver based on the extended cutting plane method, Process Design Laboratory, Abo Akademi University, Report No. 01-178-A.
- [43] Kirkpatrick, S., Gelatt, J. C. D., and Vecchi, M. P., 1982, "Optimization by Simulated Annealing," *IBM Research Report No. RC9355*.
- [44] Holland, J. H., 1975, *Adaptation in Natural and Artificial Systems*, University of Michigan Press, Ann Arbor, MI.
- [45] Beyer, H. G., and Schwefel, H. P., 2002, "Evolution Strategies, a Comprehensive Introduction," *Nat. Comput.*, **1**(1), pp. 3–52.
- [46] Yang, Y. W., Xu, J. F., and Soh, C. K. N., 2006, "An Evolutionary Programming Algorithm For Continuous Global Optimization," *Eur. J. Oper. Res.*, **168**(2), pp. 354–369.
- [47] Osadacz, A. J., 1987, *Simulation and Analysis of Gas Networks*, E. & F.N., Spon, London.
- [48] Tabkhi, F., 2007, "Optimisation de réseaux de transport de gaz," Ph.D. thesis,

Institut National Polytechnique de Toulouse, Toulouse, France.

- [49] Mohring, J., Hoffmann, J., Halfmann, T., Zemitis, A., Basso, G., and Lagoni, P., 2004, "Automated Model Reduction of Complex Gas Pipeline Networks," 36th Annual Meeting of Pipeline Simulation Interest Group, Palm Springs, CA.
- [50] Romeo, E., Royo, C., and Monzon, A., 2002, "Improved Explicit Equations for Estimation of the Friction Factor in Rough and Smooth Pipes," *Chem. Eng. J.*, **86**(3), pp. 369–374.
- [51] Menon, E. S., 2005, *Gas Pipeline Hydraulics*, CRC, Boca Raton, FL/Taylor & Francis, London.
- [52] Smith, J. M., and Van Ness, H. C., 1988, *Introduction to Chemical Engineering Thermodynamics*, 4th ed., McGraw-Hill, Singapore.
- [53] Abbaspour, M., Chapman, K. S., and Krishnaswami, P., 2005, "Nonisothermal Compressor Station Optimization," *ASME J. Energy Resour. Technol.*, **127**(2), pp. 131–141.
- [54] Odom, F. M., 1990, "Tutorials on Modelling of Gas Turbine Driven Centrifugal Compressors," 22nd Annual Meeting of Pipeline Simulation Interest Group, Baltimore, MD.
- [55] Pugnet, J. M., 1999, "Pompage des compresseurs, Techniques de l'ingénieur," *Génie mécanique*, **BL2**(BM 4 182), pp. BM4182.1–BM4182.18.
- [56] Wu, S., Rios-Mercado, R. Z., Boyd, E. A., and Scott, L. R., 2000, "Model Relaxations for the Fuel Cost Minimization of Steady-State Gas Pipeline Networks," *Math. Comput. Model.*, **31**(2–3), pp. 197–220.
- [57] Edgar, T. F., and Himmelblau, D. M., 2001, *Optimization of Chemical Processes*, McGraw-Hill, Singapore.