



HAL
open science

Dissipativity analysis of negative resistance circuits

Felix Miranda-Villatoro, Fulvio Forni, Rodolphe Sepulchre

► **To cite this version:**

Felix Miranda-Villatoro, Fulvio Forni, Rodolphe Sepulchre. Dissipativity analysis of negative resistance circuits. *Automatica*, 2022, 136, pp.110011:1-8. 10.1016/j.automatica.2021.110011. hal-03472776

HAL Id: hal-03472776

<https://hal.science/hal-03472776>

Submitted on 8 Jan 2024

HAL is a multi-disciplinary open access archive for the deposit and dissemination of scientific research documents, whether they are published or not. The documents may come from teaching and research institutions in France or abroad, or from public or private research centers.

L'archive ouverte pluridisciplinaire **HAL**, est destinée au dépôt et à la diffusion de documents scientifiques de niveau recherche, publiés ou non, émanant des établissements d'enseignement et de recherche français ou étrangers, des laboratoires publics ou privés.



Distributed under a Creative Commons Attribution - NonCommercial 4.0 International License

Dissipativity analysis of negative resistance circuits

Félix A. Miranda-Villatoro ^a, Fulvio Forni ^b, Rodolphe Sepulchre ^b

^a *Univ. Grenoble-Alpes, INRIA, CNRS, LJK, Grenoble-INP, 38000 Grenoble, France.*

^b *University of Cambridge, Department of Engineering. Trumpington Street, CB2 1PZ, Cambridge, United Kingdom.*

Abstract

This paper deals with the analysis of nonlinear circuits that interconnect passive elements (capacitors, inductors, and resistors) with nonlinear resistors exhibiting a range of *negative* resistance. Active elements are necessary to design physical circuits that switch and oscillate. We generalize the classical passivity theory of circuit analysis to develop a port interconnection theory for such non-equilibrium behaviors. The approach closely mimics the classical methodology of (incremental) dissipativity theory, but with dissipation inequalities that combine *signed* storage functions and *signed* supply rates to account for the port interconnection of passive and active elements.

Key words: Nonlinear circuits; Dissipative systems; Active elements; Limit cycles; Bistability.

1 Introduction

The concept of passivity is a foundation of circuit theory [1]. It led to the generalized concept of dissipativity [37], [38], which has become a foundation of nonlinear system theory [19,35]. Yet the applications of nonlinear system theory have been dominated by mechanical and electro-mechanical systems [6], [13], [28], [32], with significantly less attention to nonlinear circuits [5,7].

Starting with the seminal work of Chua [10] and the textbook of Chua and Desoer [11], the research on nonlinear circuits has somewhat diverged from the research on nonlinear dissipative systems. The emphasis in nonlinear circuit theory has been on non-equilibrium behaviors whereas the focus of dissipativity theory is an interconnection framework for systems that converge to equilibrium.

Negative resistance devices are the essence of non-equilibrium behaviors such as switches [9], [18], [23], nonlinear oscillations [20], [24], or chaotic behavior [22],

[31]. In contrast, dissipativity theory is a stability theory for physical systems that only dissipate energy and that relax to equilibrium when disconnected from an external source of energy.

The present paper is a step towards generalizing passivity theory to a port interconnection theory of negative resistance circuits. In the spirit of passivity theory, we seek to analyze nonlinear circuits that constrain the exchange of energy through the element ports.

The two basic elements of dissipativity theory are the storage function and the supply function. A dissipative system obeys a dissipation inequality, which expresses that the rate of change of the storage does not exceed the supply. The physical interpretation is that the storage is a measure of the internal energy, whereas the integral of the supply is a measure of the supplied energy. For stability analysis purposes, the storage becomes a Lyapunov function.

The approach in this paper is based on two modifications of the basic theory. First, the analysis is in terms of *incremental* variables, that is, differences of voltages and currents rather than voltages and currents. Incremental analysis is classical in nonlinear circuit theory. Starting with the seminal work of [25], incremental analysis has also been increasingly used in nonlinear stability theory [2], [14], and in nonlinear dissipativity theory [17], [29], [33], [36]. Second, we allow for dissipation inequalities that combine *signed* storage functions and *signed* supply

* The research leading to these results has received funding from the European Research Council under the Advanced ERC Grant Agreement Switchlet n.670645 and from the Royal Society Research Grant RGS\R1\191308.

Email addresses: felix.miranda-villatoro@inria.fr (Félix A. Miranda-Villatoro), f.forni@eng.cam.ac.uk (Fulvio Forni), r.sepulchre@eng.cam.ac.uk (Rodolphe Sepulchre).

rates. Signed storage functions have the interpretation of a difference of energy stored in different storage elements whereas signed supply rates are useful for identifying the sign of the interconnection (positive or negative feedback).

For analysis purposes, the interconnection theory developed in the present paper makes contact with the dominance theory recently proposed in [15], [16]. Signed Lyapunov functions with a restricted number of negative terms are used to prove convergence to low-dimensional dynamics that dominate the asymptotic behavior. A one-dimensional dominant behavior is sufficient to model bistable switches whereas a two-dimensional dominant behavior is sufficient to model nonlinear oscillators. Combined with the interconnection theory of this paper, dominance theory opens the way to analysis of nonlinear switches and nonlinear oscillators in large nonlinear circuits.

We deliberately restrict the scope of the present paper to nonlinear circuits with negative resistance to facilitate a concrete interpretation of the results. Not surprisingly, the concepts are not restricted to electrical circuits and apply to any physical domain. For concreteness, the entire paper is restricted to *signed* passivity supplies, an inner product between currents and voltages, with the convenient interpretation of electrical power.

A main contribution of the present paper with respect to [16] is the consideration of physical interconnections between elements that can be active, that is, include internal sources of energy. The consideration of port interconnections is key to the application of dissipativity theory to physical systems.

The paper is organized as follows. Section 2 deals with the dissipation properties of negative resistance devices and Section 3 extends dominance theory in an incremental framework that is suitable for the analysis of circuits with piecewise linear characteristics. In Section 4 we analyze basic electrical switches and oscillators with one or two storage elements, whereas Section 5 covers the design of coupling networks that allows us to interconnect circuits with different signatures in the supply rates.

Preamble.

The circuits studied in this paper are built from interconnections of *linear passive* elements, such as capacitors and inductors, and *nonlinear* resistors. The time evolution of the family of circuits studied here is described by the state-space model

$$\Sigma : \begin{cases} \dot{x} = f(x) + Bu & x(0) = x_0 \\ y = Cx + Du \end{cases} \quad (1)$$

where $x \in \mathbb{R}^n$ is the state of the system and $u, y \in \mathbb{R}^m$ are the so-called manifest variables. For electrical circuits, the manifest variables are conjugated in terms of voltages v , and

currents i , that is, the inner product $u^\top y$ has units of power. The map $f : \mathbb{R}^n \rightarrow \mathbb{R}^n$ is Lipschitz continuous and models interactions between linear storage elements and nonlinear resistors. Moreover, the matrices B, C , and D are of the appropriate dimensions and such that the system is well-posed. Henceforth, every circuit in this paper is assumed to be of the form (1). We adopt a *differential* (or incremental) approach, that is, we will study circuit properties by looking at the difference between trajectories. For simplicity, we denote the difference between any two generic signals w_1, w_2 as $\Delta w := w_1 - w_2$. In this way, the mismatches between any two states/currents/voltages are denoted as $\Delta x, \Delta i$ and Δv respectively. Finally, we will use symmetric matrices $P \in \mathbb{R}^{n \times n}$ constrained to have inertia $(p, 0, n - p)$, that is, with p negative eigenvalues and $n - p$ positive eigenvalues.

2 Signed supply rates for nonlinear resistors

The nonlinear element shown in Figure 1 is a fundamental element of nonlinear circuits. The range of negative slope in the nonlinear characteristic models an element that reduces its energy dissipation for increasing values of voltage/current. By adding power sources, such a nonlinear element can model an active device injecting power into the circuit. We follow the common terminology of *negative resistance* device [12], [21], with the usual caveat that *negative* refers to the *increment* Δv rather than to the value of the voltage v . A more precise (but also heavier) terminology would be *negative incremental (or differential) resistance*. The analysis in this paper will be exclusively in terms of *incremental* quantities, which is common practice in nonlinear circuit theory.

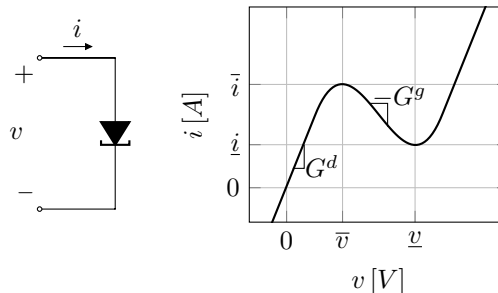

Fig. 1. Slope-bounded voltage-current characteristic of a tunnel diode. Tunnel diodes are (incrementally) negative resistance devices. When a power source is added to work on the region of negative slope, the device becomes *active*.

We are motivated by the property that this nonlinear element satisfies the two inequalities

$$0 \leq \Delta i \Delta v + G^g (\Delta v)^2, \quad 0 \leq -\Delta i \Delta v + G^d (\Delta v)^2 \quad (2)$$

where $G^d > 0$ and $-G^g < 0$ represent, respectively, the maximum positive slope and negative slope of the voltage-current characteristic of Figure 1. Both inequalities have an obvious energetic interpretation: the first inequality expresses the shortage of incremental passivity

of the element: the element becomes incrementally passive when connected in parallel with a resistor of resistance lesser than $1/G^g$. The second inequality expresses the shortage of incremental anti-passivity of the element: the element becomes purely a source of energy when connected to a negative resistance larger than $-1/G^d$.

The element illustrated in Figure 1 is passive, but the addition of a constant power source does not change the incremental dissipation inequality (2). As a consequence, incremental dissipation inequalities apply to both passive and active elements.

Describing negative resistors in terms of dissipation inequalities opens the way to the use of dissipativity theory to characterize circuit interconnections. As an illustration, consider the parallel interconnection of a voltage-controlled¹ negative resistance element with a capacitor (Figure 2, left).

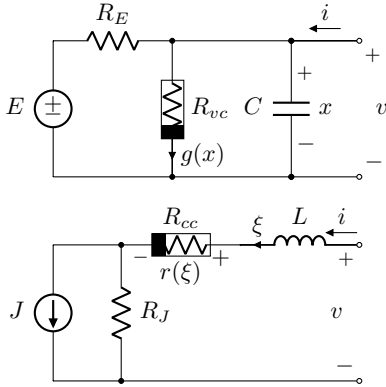

Fig. 2. Basic prototype circuits of a current-driven (above) and a voltage-driven (below) 1-passive circuit. The resistors R_{vc} and R_{cc} are voltage-controlled and current-controlled resistors respectively.

Let i^c, v^c and i^r, v^r be the currents and voltages associated to the capacitor and the controlled resistor, respectively. The capacitor is a classical lossless element that satisfies the power-preserving equality

$$\frac{d}{dt} C \frac{(\Delta v^c)^2}{2} = \Delta v^c \Delta i^c \quad (3)$$

In the language of dissipativity theory, the quantity on the left-hand side is the time-derivative of the *storage* $C \frac{(\Delta v^c)^2}{2}$. The negative resistance element together with the source and the resistor R_E satisfy $-\Delta v^r \Delta i^r + (G^d + \frac{1}{R_E})(\Delta v^r)^2 \geq 0$. The parallel interconnection defined by

¹ A voltage-controlled resistor is a device for which the current flowing through its terminals is a single-valued map of its voltage. The dual element, for which the voltage across its terminals is a single-valued function of its current, is a current-controlled resistor.

$v = v^c = v^r$ and $i = i^c + i^r$ satisfies the dissipation (in)equality

$$-\frac{d}{dt} C \frac{(\Delta v^c)^2}{2} \leq -\Delta v \Delta i + \left(G^d + \frac{1}{R_E} \right) (\Delta v)^2 \quad (4)$$

The quantity that appears on the left hand-side is the time-derivative of a *negative* storage. More generally, the storage functions in this paper will be quadratic forms defined by a symmetric matrix $P = P^T$ with p negative eigenvalues (and $n - p$ positive eigenvalues). In the same way, we will consider quadratic supply rates as

$$\sigma(\Delta i, \Delta v) = \begin{bmatrix} \Delta i \\ \Delta v \end{bmatrix}^T \begin{bmatrix} \mathcal{Q} & \mathcal{I} \\ \mathcal{I} & \mathcal{R} \end{bmatrix} \begin{bmatrix} \Delta i \\ \Delta v \end{bmatrix} \quad (5)$$

where the signature matrix $\mathcal{I} \in \mathbb{R}^{m \times m}$ is a diagonal matrix with ± 1 in the main diagonal, and $\mathcal{Q} \in \mathbb{R}^{m \times m}$, $\mathcal{R} \in \mathbb{R}^{m \times m}$ are symmetric matrices. In the special case $\mathcal{I} = I$, this family of supply rates characterize incrementally passive elements with an excess or a shortage of passivity in the external variables [32].

We call (5) a *signed* passivity supply rate to stress that the only difference with respect to the conventional passivity supply is the signature matrix \mathcal{I} generalizing the conventional identity matrix I .

Signed storage functions generalize the conventional *positive definite* storages of passivity theory. Positive definite storages are natural candidates for the stability analysis of closed equilibrium systems. In its incremental form, stability analysis appears in the literature under different names, including *contraction* theory [25], *incremental* stability analysis [2], or differential Lyapunov analysis [14]. *Signed* storages generalize this stability analysis for non-equilibrium behaviors characterized by a low-dimensional asymptotic behavior. This generalization is the topic of dominance analysis, reviewed in the next section.

3 Differential dissipativity

3.1 Signed passivity

Dissipativity theory [37], [38] is grounded in dissipation inequalities, which generalize the physical characterization of a passive circuit as a system that can only absorb energy: the variation of energy *stored* in the elements of the circuit (capacitors and inductors) is upper bounded by the electrical power *supplied* to the circuit. For a linear circuit, the storage is a quadratic function of the state, and the dissipation inequality takes the standard form

$$\frac{d}{dt} x^T P x + 2\lambda x^T P x \leq v^T i + i^T v$$

The scalar $\lambda \geq 0$ determines a dissipation rate. Each pair of voltage v_k and current i_k appearing in the voltage vector v and current vector i determines a port of the circuit. Motivated by the signed supply rates and signed storages introduced in Section 2, we generalize incremental passivity to *signed* passivity.

$$\frac{d}{dt}S(\Delta x) + 2\lambda S(\Delta x) \leq \sigma(\Delta i, \Delta v) \quad (6)$$

where $S(\Delta x) = \Delta x^\top P \Delta x$, and the inequality has to hold for any mismatch Δi , Δv , and Δx satisfying (1) (with the appropriate identification of the elements of the vectors u and y in (1)). The *signed* supply $\sigma : \mathbb{R}^m \times \mathbb{R}^m \rightarrow \mathbb{R}$ is determined by the signature matrix \mathcal{I} . The *signed* quadratic storage $S : \mathbb{R}^n \rightarrow \mathbb{R}$ is determined by the symmetric matrix P with p negative eigenvalues and $n - p$ positive eigenvalues. Signed quadratic storages arise from the difference between two non-negative functions. If the storage function S is positive definite, the scalar $\lambda \geq 0$ indicates a dissipation rate. For generic signed storage functions, the rate λ splits the circuit dynamics into a *contracting* part, whose dissipation rate is upper bounded by λ , and a *dominant* part, whose dissipation is only *lower bounded* by λ . The objective of the generalized theory is to consider port-interconnections of circuits whose elements can possibly inject energy *into* the environment rather than exclusively dissipating energy *from* the environment.

Definition 1 A nonlinear circuit (1) is called *signed passive* with rate $\lambda \geq 0$, if the inequality (6) holds along any pair of trajectories. The property is *strict* if $\varepsilon > 0$.

Definition 1 is very close to the classical definition of incremental passivity. The only difference is that (i) we consider *signed* storages, i.e. *differences* of nonnegative storages and (ii) *signed* supply rates, i.e. *differences* of the classical *passivity* supply rates. As illustrated in Section 2, such storages and supply rates appear naturally when considering circuits with both passive and active elements and ports that can both absorb and deliver energy.

3.2 Dissipative interconnections

The central property of passivity theory is that passivity is preserved by interconnection. More precisely, port interconnections of passive circuits are passive. In order to generalize this property to signed-passivity, we introduce the following definition.

Definition 2 Let Σ_a and Σ_b be two signed-passive circuits with rate $\lambda \geq 0$. Their interconnection is called *dissipative* if

$$\Delta i^a{}^\top \mathcal{I}_a \Delta v^a + \Delta i^b{}^\top \mathcal{I}_b \Delta v^b \leq \Delta i \mathcal{I} \Delta v \quad (7)$$

for some new port variables $i, v \in \mathbb{R}^{\tilde{m}}$ and $\mathcal{I} \in \mathbb{R}^{\tilde{m} \times \tilde{m}}$. If equality holds in (7), then the interconnection is called *neutral*.

The conventional passivity supply assumes $\mathcal{I} = I$. In this case, an interconnection is *neutral* if

$$\Delta i^a{}^\top \Delta v^a + \Delta i^b{}^\top \Delta v^b = \Delta i{}^\top \Delta v$$

Hence, port interconnections of passive circuits are neutral. Concretely, we consider the following interconnection pattern,

$$\begin{aligned} i^a &= -i^b + i^{cc} & i^b &= -i^{vc} \\ v^a &= v^b + v^{vc} & v^a &= v^{cc} \end{aligned} \quad (8)$$

with

$$i_k^{cc\top} v_k^{vc} = 0, \text{ for all } k \in \{1, \dots, m\} \quad (9)$$

The connection pattern (8) describe combinations of the two most common interconnection patterns for circuits, that is, parallel connection ($v^{vc} = 0$), and series connection ($i^{cc} = 0$). Note that a circuit is closed or terminated whenever both $i^{cc} = 0$ and $v^{vc} = 0$. Substitution of (8) on the left-hand side of (7) shows that port interconnections of signed-passive systems with supplies sharing the same signature (i.e., $\mathcal{I}_a = \mathcal{I}_b$) are neutral in the sense of Definition 2 with respect to $i = [i^{cc\top}, i^{vc\top}]^\top$, $v = [v^{cc\top}, v^{vc\top}]^\top$, and $\mathcal{I} = \text{Diag}[\mathcal{I}_a, \mathcal{I}_b]$.

The question of how to realize a neutral or dissipative interconnection when interconnecting signed-passive circuits is deferred to Section 5. But the definition allows for the following generalization of the passivity theorem.

Theorem 3 The dissipative interconnection of two signed-passive circuits with rate $\lambda \geq 0$ is signed-passive with the same rate. The storage of the interconnected system is the sum of the storages.

PROOF. Let us consider the aggregated state $x = [x_a^\top, x_b^\top]^\top$, and the block-diagonal matrix $P = \text{Diag}[P_a, P_b]$ such that $S(\Delta x) = \Delta x^\top P \Delta x$. The sum of storages satisfies,

$$\frac{d}{dt}S(\Delta x) + 2\lambda S(\Delta x) \leq \sum_{k \in \{a,b\}} \sigma_k(\Delta i^k, \Delta v^k) \quad (10)$$

Simple, yet cumbersome, computations show that the substitution of the interconnection pattern (8) into (10) together with the dissipativity of the interconnection yield,

$$\frac{d}{dt}S(\Delta x) + 2\lambda S(\Delta x) \leq \hat{\sigma}(\Delta i, \Delta v) \quad (11)$$

where $\hat{\mathcal{I}} = \text{Diag}[\mathcal{I}_a, \mathcal{I}_b]$ and

$$\hat{\mathcal{Q}} = \begin{bmatrix} \mathcal{Q}_a & \mathcal{Q}_a \\ \mathcal{Q}_a & \mathcal{Q}_a + \mathcal{Q}_b \end{bmatrix} \quad \hat{\mathcal{R}} = \begin{bmatrix} \mathcal{R}_a + \mathcal{R}_b & -\mathcal{R}_b \\ -\mathcal{R}_b & \mathcal{R}_b \end{bmatrix}$$

and the result follows. \square

The dissipation rate λ splits the circuit dynamics between contracting and dominant parts. The common rate in Theorem 3 guarantees that the interconnection preserves the splitting of the parts. This does not force the two circuits to have the same dissipation elements or equal dissipated powers. For example, for a given rate λ , Σ_a may dissipate at a fast rate, faster than λ , while Σ_b may be slow or not dissipate at all (the rate λ is a lower bound). Under the assumptions of Theorem 3, the interconnection of Σ_a and Σ_b is sign-passive with a well defined splitting into contractive and dominant parts separated by the rate λ (respectively given by the dynamics of Σ_a and Σ_b , in this case).

3.3 Closing the ports: Dominant systems

Signed passivity enables the analysis of interconnected circuits that combine passive and active components. In this section we show how signed passivity constrains the behavior of the system. The bridge is given by dominance theory, which takes advantage of the splitting into dominant and contractive components of signed passivity, to characterize the non-equilibrium behaviors of the system. The approach is based on the intuitive idea that the long run behavior of the system is dictated by low-dimensional dynamics, identified through the study of the system linearization [14], [15], [16]. In what follows, we adapt the differential approach of [16] into an incremental setting.

Definition 4 Let $f : \mathbb{R}^n \rightarrow \mathbb{R}^n$ be a Lipschitz continuous map. A system of the form

$$\dot{x} \in f(x), \quad x \in \mathbb{R}^n, \quad (12)$$

is p -dominant with rate $\lambda \geq 0$ if there exists a matrix $P = P^\top \in \mathbb{R}^{n \times n}$ with inertia $(p, 0, n - p)$ such that for any two trajectories of (12)

$$\begin{bmatrix} \Delta \dot{x} \\ \Delta x \end{bmatrix}^\top \begin{bmatrix} 0 & P \\ P & 2\lambda P + \varepsilon I \end{bmatrix} \begin{bmatrix} \Delta \dot{x} \\ \Delta x \end{bmatrix} \leq 0. \quad (13)$$

The property is strict if $\varepsilon > 0$.

When P is positive definite, (13) becomes the incremental analogue of the classical Lyapunov inequality, meaning that any two trajectories converge to each other with

decay rate at least $\lambda \geq 0$, [4]. When f is a differentiable map, (13) reduces to the simple matrix inequality

$$\frac{\partial f(x)}{\partial x}^\top P + P \frac{\partial f(x)}{\partial x} + 2\lambda P \leq -\varepsilon I, \forall x \in \mathbb{R}^n \quad (14)$$

which provides a basic test for dominance, [15], [16].

The property of dominance strongly constrains the asymptotic behavior of the system as described for the following theorem.

Theorem 5 ([16, Corollary 1]) Let (12) be strictly p -dominant with rate $\lambda \geq 0$. Then every bounded trajectory of (12) converges to

- A unique equilibrium point if $p = 0$.
- An equilibrium point if $p = 1$.
- A simple attractor if $p = 2$. That is, an equilibrium point, a set of equilibria and connecting arcs, or a closed orbit.

Summing up, closed dynamic systems with smaller degrees of dominance p will show simpler behaviors compared with systems with higher degrees.

A key consequence of the classical passivity theorem is that terminated passive circuits converges to a unique stable equilibrium. The storage becomes a Lyapunov function for the closed system. In a similar way, terminated signed-passive circuits are dominant systems, whose behavior satisfies Theorem 5. The number of negative eigenvalues of their storage function is connected to the degree of dominance of the circuit.

Theorem 6 Let Σ_a be a strictly signed-passive circuit with rate $\lambda > 0$ and dominance degree p . The terminated circuit built from the dissipative interconnection of Σ_a with a resistor (Σ_b) defines a p -dominant system with the same rate $\lambda > 0$ provided that $\mathcal{Q}_a + \mathcal{Q}_b \leq 0$ and $\mathcal{R}_a + \mathcal{R}_b \leq 0$.

PROOF. Recall that a resistor (linear or nonlinear) satisfies a dissipation inequality as (5). Thus, from Theorem 3, the interconnection satisfies (11). In addition, the termination of the ports, i.e., $i^{cc} = 0$ and $v^{vc} = 0$, transforms (11) into

$$\begin{aligned} \frac{d}{dt} S(\Delta x) + 2\lambda S(\Delta x) &\leq \Delta i^{vc\top} (\mathcal{Q}_a + \mathcal{Q}_b) \Delta i^{vc} \\ &\quad + \Delta v^{cc\top} (\mathcal{R}_a + \mathcal{R}_b) \Delta v^{cc} \leq 0 \end{aligned}$$

and the conclusion follows from Definition 4. \square

4 Elementary switching and oscillating circuits

In this section we review classical elementary circuits and illustrate their signed passivity properties. In what follows, we make extensive use of Theorems 5 and 6 for the analysis of interconnected circuits.

4.1 Switching circuits

We start with the parallel nonlinear RC circuit and the series nonlinear RL circuit shown in Figure 2. For the nonlinear RC circuit, we rewrite the dissipation inequality (4) with state $x = v^c$ and storage $S(\Delta x) = -\frac{C}{2}(\Delta x)^2$ as

$$\begin{aligned} \frac{d}{dt}S(\Delta x) + 2\lambda S(\Delta x) &\leq -\Delta i \Delta v \\ &+ \left(G^d + \frac{1}{R_E} - \lambda C \right) (\Delta v)^2 \end{aligned} \quad (15)$$

The dissipation inequality involves the standard storage of a capacitor and the standard supply of a one port circuit, but both with a negative signature. The interconnection is neutral as a port interconnection of elements with negative signature $\mathcal{I} = -1$. Terminating the circuit, that is, setting $i = 0$, results in a 1-dominant system when $G^d + \frac{1}{R_E} - \lambda C < 0$ (Theorem 6). This closed circuit has one or three equilibria. With three equilibria, one of which unstable, the circuit is an elementary example of bistable switch (Theorem 5).

The dissipativity analysis of the series RL circuit in Figure 2 is similar. Taking as state variable ξ and storage function $S(\Delta \xi) = -\frac{L}{2}(\Delta \xi)^2$, the circuit satisfies the dissipation inequality

$$\begin{aligned} \frac{d}{dt}S(\Delta \xi) + 2\lambda S(\Delta \xi) &\leq -\Delta i \Delta v \\ &+ (R^d + R_J - \lambda L)(\Delta i)^2 \end{aligned} \quad (16)$$

By applying once again Theorems 5 and 6 we conclude that the circuit is 1-passive whenever $R^d + R_J - \lambda L < 0$, and a bistable switch whenever there are three equilibria one of which unstable. Both circuits can be seen as abstract realizations of the classical Schmitt trigger circuit in which the negative resistor is usually made by using an operational amplifier in positive feedback [26].

Both switches in Figure 2 have a signed storage and a signed supply rate. The sign in the storage function dictates the degree of dominance p , whereas the sign in the supply rate constrains the feasible dissipative interconnections for the port. For instance, consider the circuits of Figure 2 with different interconnection ports as indicated in Figure 3. In this case, the dissipation inequality associated to the nonlinear RC circuit with the same

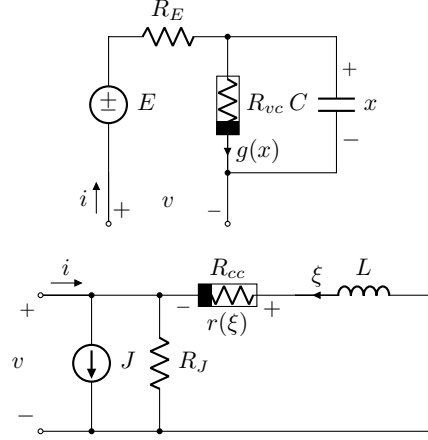

Fig. 3. Other two basic switches with supply rate given by $\mathcal{I} = 1$ (in contrast to the circuits in Figure 2 where $\mathcal{I} = -1$).

storage function $S(\Delta x) = -\frac{C}{2}(\Delta x)^2$, is

$$\begin{aligned} \frac{d}{dt}S(\Delta x) + 2\lambda S(\Delta x) &\leq \Delta i \Delta v - \frac{1}{R_E}(\Delta v)^2 \\ &+ \left(G^d + \frac{1}{R_E} - \lambda C \right) (\Delta x)^2 \end{aligned} \quad (17)$$

That is, the circuit is strictly 1-passive when $G^d + \frac{1}{R_E} - \lambda C < 0$. The associated supply rate is positive in this situation ($\mathcal{I} = 1$). Similarly, for the nonlinear RL circuit of Figure 3, the corresponding dissipation inequality is

$$\begin{aligned} \frac{d}{dt}S(\Delta \xi) + 2\lambda S(\Delta \xi) &\leq \Delta i \Delta v - R_J(\Delta i)^2 \\ &+ (R_J + R^d - \lambda L)(\Delta \xi)^2 \end{aligned} \quad (18)$$

Note that both set of circuits in Figures 2 and 3 are 1-passive with the same storage functions and even the same rate $\lambda > 0$. However, the difference of sign in the supply rate will yield to different types of dissipative interconnections.

4.2 Oscillating circuits

We proceed with the analysis of the nonlinear RLC circuits shown in Figure 4.

The parallel nonlinear RLC circuit is the port interconnection of the nonlinear RC circuit in the previous section with a lossless inductor via the pattern (8) with $v^{vc} = 0$. The port interconnection is neutral as an interconnection of two circuits with supply signature $\mathcal{I} = -1$. The total storage is the sum of two negative storages (defining the state $\Delta z = [\Delta x \ \Delta \xi]^T$)

$$S(\Delta z) := -\frac{C}{2}(\Delta x)^2 - \frac{L}{2}(\Delta \xi)^2.$$

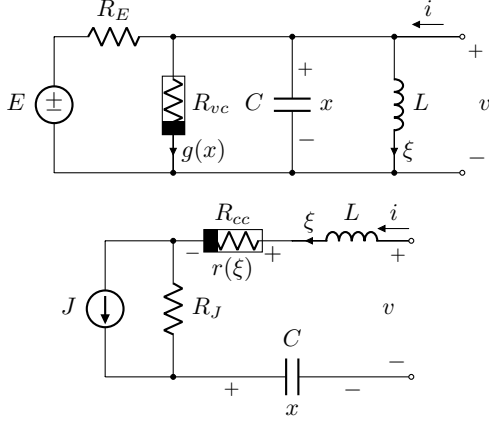

Fig. 4. Basic prototype circuits of a current-controlled (above) and a voltage-controlled (below) signed-passive circuits with degree of dominance 2.

The interconnection satisfies the dissipation inequality

$$\begin{aligned} \frac{d}{dt}S(\Delta z) + 2\lambda S(\Delta z) \leq & -\Delta i \Delta v - \lambda L(\Delta i)^2 \\ & + (G^d + \frac{1}{R_E} - \lambda C)(\Delta v)^2 \end{aligned}$$

The storage has a dominance degree 2 and the supply has a negative signature $\mathcal{I} = -1$. When terminated, that is, when $i = 0$, the circuit is 2-dominant for $G^d + \frac{1}{R_E} < \lambda C$ (Theorem 6). If in addition, the closed circuit has a unique unstable equilibrium and bounded trajectories, then a self-sustained oscillation appears. This is a prototype of negative resistance nonlinear oscillator, see Theorem 5, such as the circuits studied by Van der Pol [34] and Nagumo [27].

The series interconnection in Figure 4 can be studied in a similar way, as a neutral interconnection between the nonlinear RL circuit in the previous section and a lossless capacitor. The circuit is signed dissipative with the same storage and with the supply

$$\sigma(\Delta i, \Delta v) = \frac{1}{2} \begin{bmatrix} \Delta i \\ \Delta v \end{bmatrix}^\top \begin{bmatrix} 2(R^d + R_J - \lambda L) & -1 \\ -1 & -2\lambda C \end{bmatrix} \begin{bmatrix} \Delta i \\ \Delta v \end{bmatrix}$$

5 Dissipative interconnections

The examples of Section 4 are built from the dissipative connection of circuits with the same sign on their supply rate, so that Theorem 3 can be applied. However, the simple port-interconnection of signed-passive circuits with opposite supply rates, i.e., $\mathcal{I}_a + \mathcal{I}_b = 0$, is non-dissipative. For such circuits, dissipative interconnections require coupling through additional circuits that may be active as well.

We illustrate the construction of such coupling networks with the *static coupling network* shown in Figure 5. The

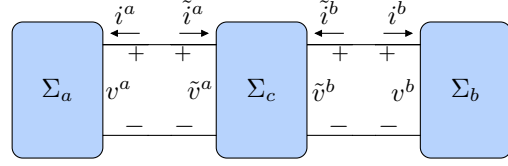

Fig. 5. Dissipative interconnection of circuits Σ_a and Σ_b through the static coupling network Σ_c .

interconnection equations are

$$\begin{aligned} i^k &= -\tilde{i}^k + i^{k,cc}, & \tilde{i}^k &= -i^{k,vc} \\ v^k &= \tilde{v}^k + v^{k,vc}, & v^k &= v^{k,cc} \end{aligned} \quad (19)$$

where the variables $i^{k,cc}$, $v^{k,cc}$, $i^{k,vc}$ and $v^{k,vc}$, $k \in \{a, b\}$, represent the range of possible ports available after interconnection. With this notation, a port is closed or terminated when $i^{k,cc} = 0$ and $v^{k,vc} = 0$, $k \in \{a, b\}$ which is the case shown in Figure 5.

The following theorem provides conditions on the static coupling network Σ_c that lead to a dissipative interconnection (in the sense of Definition 2), between the circuits Σ_a and Σ_b so that Theorem 3 can be applied. In what follows $\tilde{\sigma}(\Delta \tilde{i}, \Delta \tilde{v})$ denotes the supply rate associated to Σ_c , that is,

$$\tilde{\sigma}(\Delta \tilde{i}, \Delta \tilde{v}) = \begin{bmatrix} \Delta \tilde{i} \\ \Delta \tilde{v} \end{bmatrix}^\top \begin{bmatrix} \tilde{\mathcal{Q}} & \tilde{\mathcal{I}} \\ \tilde{\mathcal{I}} & \tilde{\mathcal{R}} \end{bmatrix} \begin{bmatrix} \Delta \tilde{i} \\ \Delta \tilde{v} \end{bmatrix}$$

where $\Delta \tilde{i} = [\Delta \tilde{i}^a, \Delta \tilde{i}^b]^\top$, $\Delta \tilde{v} = [\Delta \tilde{v}^a, \Delta \tilde{v}^b]^\top$, $\tilde{\mathcal{I}} = \text{Diag}[\mathcal{I}_a, \mathcal{I}_b]$, $\tilde{\mathcal{Q}} = \text{Diag}[\tilde{\mathcal{Q}}_a, \tilde{\mathcal{Q}}_b]$, $\tilde{\mathcal{R}} = \text{Diag}[\tilde{\mathcal{R}}_a, \tilde{\mathcal{R}}_b]$.

Theorem 7 *The interconnection between Σ_a and Σ_b is dissipative, in the sense of Definition 2, if and only if the static coupling network Σ_c is signed-passive without any shortage of signed-passivity, that is, if and only if Σ_c satisfies, for any mismatch $\Delta \tilde{i}, \Delta \tilde{v}$,*

$$0 \leq \tilde{\sigma}(\Delta \tilde{i}, \Delta \tilde{v}) \quad (20)$$

with $\tilde{\mathcal{Q}} \leq 0$, $\tilde{\mathcal{R}} \leq 0$. In addition, the interconnection is neutral if and only if,

$$0 = \Delta \tilde{i}^a \mathcal{I}_a \Delta \tilde{v}^a + \Delta \tilde{i}^b \mathcal{I}_b \Delta \tilde{v}^b \quad (21)$$

PROOF. The left-hand side of (7) under the intercon-

nection pattern (19) yields,

$$\begin{aligned}
& \Delta i^a \mathcal{I}_a \Delta v^a + \Delta i^b \mathcal{I}_b \Delta v^b \\
&= \sum_{k \in \{a,b\}} -\Delta \tilde{i}^k \mathcal{I}_k \Delta \tilde{v}^k \\
&\quad + \sum_{k \in \{a,b\}} \Delta i^{k,cc} \mathcal{I}_k \Delta v^{k,cc} + \Delta i^{k,vc} \mathcal{I}_k \Delta v^{k,vc} \quad (22) \\
&\leq \sum_{k \in \{a,b\}} \Delta i^{k,cc} \mathcal{I}_k \Delta v^{k,cc} + \Delta i^{k,vc} \mathcal{I}_k \Delta v^{k,vc}
\end{aligned}$$

where we have made use of (20) in the last step. Hence, (7) follows by taking $i = [i^{a,cc}, i^{b,cc}, i^{a,vc}, i^{b,vc}]^\top$, $v = [v^{a,cc}, v^{b,cc}, v^{a,vc}, v^{b,vc}]^\top$, and $\mathcal{I} = \text{Diag}[\mathcal{I}_a, \mathcal{I}_b, \mathcal{I}_a, \mathcal{I}_b]$. Finally, it follows from (22) that the connection is neutral if and only if (21) holds. \square

The addition of the network Σ_c adds *signed* dissipation to both systems, allowing the following extension of Theorem 6 for circuits whose port-interconnection is originally non-dissipative.

Corollary 8 *Let Σ_a be a strictly signed-passive circuit with rate $\lambda > 0$ and dominance degree p . The terminated circuit built from the dissipative interconnection of Σ_a with a resistor (Σ_b) through a static coupling Σ_c defines a p -dominant system with the same rate $\lambda > 0$ provided that for any pair $(\Delta i^k, \Delta v^k)$, $k \in \{a, b\}$,*

$$\sum_{k \in \{a,b\}} \begin{bmatrix} \Delta i^k \\ \Delta v^k \end{bmatrix}^\top \begin{bmatrix} \mathcal{Q}_k + \tilde{\mathcal{Q}}_k & 0 \\ 0 & \mathcal{R}_k + \tilde{\mathcal{R}}_k \end{bmatrix} \begin{bmatrix} \Delta i^k \\ \Delta v^k \end{bmatrix} \leq 0 \quad (23)$$

In what follows, we look into networks that satisfy the conditions of Theorem 7, focusing on static (resistive) ‘‘T’’ and ‘‘II’’ configurations. Such configurations are widely used in the design of circuits for impedance matching and optimal power transfer between ports, see e.g., [3]. Figure 6 illustrate practical realizations of dissipative interconnections where resistive elements model power losses.

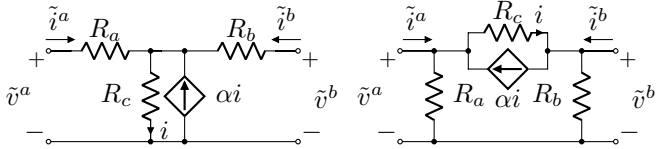

Fig. 6. ‘‘T’’ (left) and ‘‘II’’ (right) coupling systems Σ_c (see Figure 5), using a current-controlled current source for the cases when $\mathcal{I}_a = -\mathcal{I}_b$.

The ‘‘T’’ connection in Figure 6 imposes the constraints $i^a = -\tilde{i}^a$, $i^b = -\tilde{i}^b$, $v^a = \tilde{v}^a = R_a \tilde{i}^a - \frac{R_c}{\alpha-1} (\tilde{i}^a + \tilde{i}^b)$, $v^b =$

$\tilde{v}^b = R_b \tilde{i}^b - \frac{R_c}{\alpha-1} (\tilde{i}^a + \tilde{i}^b)$ where $\alpha > 1$. Without loss of generality we assume that $\mathcal{I}_a = -1$ and $\mathcal{I}_b = 1$. It follows from direct computations that the ‘‘T’’ bridge satisfies (20) with $\tilde{\mathcal{Q}}_a = R_a - \frac{R_c}{\alpha-1}$, $\tilde{\mathcal{R}}_a = 0$, $\tilde{\mathcal{Q}}_b = \frac{R_c}{\alpha-1} - R_b$, and $\tilde{\mathcal{R}}_b = 0$. Hence, according to Theorem 7, the ‘‘T’’ bridge achieves a dissipative interconnection for circuits with supply rates $\mathcal{I}_a = -1$, $\mathcal{I}_b = 1$, whenever $\alpha > 1$ and

$$R_a \leq \frac{R_c}{\alpha-1} \leq R_b \quad (24)$$

Neutrality of the interconnection is achieved if equality holds in (24).

The dual version of the ‘‘T’’ connection is the ‘‘II’’ connection as shown in Figure 6. In this case the network imposes the relations $v^a = \tilde{v}^a$, $v^b = \tilde{v}^b$, $-i^a = \tilde{i}^a = \frac{1}{R_a} \tilde{v}^a - \frac{\alpha-1}{R_c} (\tilde{v}^a - \tilde{v}^b)$, and $-i^b = \tilde{i}^b = \frac{1}{R_b} \tilde{v}^b + \frac{\alpha-1}{R_c} (\tilde{v}^a - \tilde{v}^b)$ where $\alpha > 1$. Hence, direct computations show that the ‘‘II’’ bridge also satisfies (20) with $\tilde{\mathcal{Q}}_a = 0$, $\tilde{\mathcal{R}}_a = \frac{1}{R_a} - \frac{\alpha-1}{R_c}$, $\tilde{\mathcal{Q}}_b = 0$, and $\tilde{\mathcal{R}}_b = \frac{\alpha-1}{R_c} - \frac{1}{R_b}$. Following again Theorem 7, the ‘‘II’’ bridge provides an interconnection that is dissipative whenever

$$\frac{1}{R_a} \leq \frac{\alpha-1}{R_c} \leq \frac{1}{R_b}. \quad (25)$$

Neutrality of the interconnection is achieved if equality holds in (25). Both dissipative interconnections above can be implemented by using negative resistance devices as shown in Figure 7. One should stress that the implementations in Figure 7 only consider the active range of the controlled resistors R_{vc} and R_{cc} .

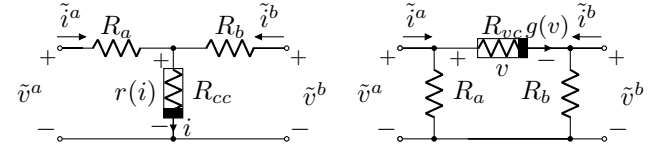

Fig. 7. Implementation of dissipative ‘‘T’’ (left) and ‘‘II’’ (right) interconnections via controlled resistors. Both interconnection networks are dissipative for systems with opposite supply signature $\mathcal{I}_a = -\mathcal{I}_b$ in the active range of the controlled resistors.

6 Example

As an illustration, we consider the circuit shown in Figure 8. The circuits Σ_{a_1} and Σ_{a_2} are the negative resistance switches analyzed in Section 4. From (15)-(16) it becomes clear that their interconnection (denoted as Σ_a) is neutral. In addition, Theorem 3 reveals that the resulting circuit is signed-passive with a negative storage (of dominance degree 2) and a passivity supply with negative signature -1 , for all $\lambda > \max\{\frac{G^d}{C_0}, \frac{R^d}{L_0}\}$, where

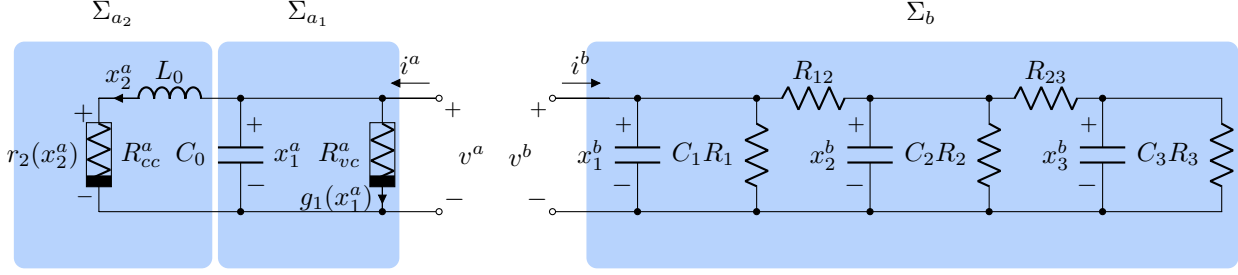

Fig. 8. Negative resistance oscillator (left) and passive RC load (right). Each circuit has opposite signature making necessary a coupling network to achieve a dissipative interconnection.

G^d and R^d are the positive slopes of the voltage-current characteristics of R_{cc}^a and R_{vc}^a respectively.

The circuit Σ_b is a classical linear RC passive load. It is signed-passive with positive signature supply $+1$, for $\lambda < \min_{k \in \{1,2,3\}} \left\{ \frac{1}{R_k C_k} \right\}$.

According to Theorems 5 and 6, closing the circuit Σ_a will result in an oscillatory behavior, whenever the associated equilibrium is unique and unstable. On the other hand, closing the circuit Σ_b will result in a circuit whose state variables go exponentially to zero. However, because the supply rates of both circuits have opposite signs, the methods developed in [16] are inconclusive regarding the behavior of the port interconnection. Indeed, in the language of [16], the interconnected system is 2-dissipative but it is not 2-dominant. Hence, a coupling network Σ_c is needed in order to get a dissipative interconnection in the sense of Definition 2.

When the two circuits are interconnected through the “ Π ” bridge discussed in the previous section, (following the pattern shown in Figure 5), the interconnection becomes dissipative as long as (25) holds. As a consequence, the interconnected circuit is signed-passive (Theorem 7). Its storage is the difference of two positive definite storages. It has a dominance degree 2. The supply of the interconnected system is a passivity supply with positive signature $+1$. This time, Theorem 6 guarantees that the terminated circuit is 2 dominant for any rate λ satisfying

$$\max \left\{ \frac{G^d}{C_0}, \frac{R^d}{L_0} \right\} < \lambda < \min_{k \in \{1,2,3\}} \left\{ \frac{1}{R_k C_k} \right\}.$$

Finally, the simulation in Figure 9 is for the set of parameters $L_0 = 50mH$, $C_0 = 10\mu F$, $C_1 = C_2 = C_3 = 0.1\mu F$, $R_1 = R_2 = R_3 = R_{12} = R_{23} = 1\Omega$, $R_a = 20\Omega$, and $R_b = 10\Omega$. The nonlinear resistors R_{vc}^a , R_{cc}^a and R_{vc}^c have voltage-current characteristics given by

$$g_1(x_1) = \begin{cases} 0.1x_1 & x_1 < 2V \\ -0.1x_1 + 0.4 & 2V \leq x_1 \leq 3V \\ 0.1x_1 - 0.2 & 3V < x_1 \end{cases}$$

$$r_2(x_2) = \begin{cases} 10x_2 + 5 & x_2 < -0.2A \\ -10x_2 + 1 & -0.2A \leq x_2 \leq -0.1A \\ 10x_2 + 3 & -0.1A < x_2 \end{cases}$$

$$g_2(v) = \begin{cases} 0.1375v + 0.9625 & v < -5V \\ -0.055v & -5V \leq v \leq 5V \\ 0.1375v - 0.9625 & 5V \leq v \end{cases}$$

Note that the resistor R_{vc}^c has region of negative resistance with gain of -0.055 and satisfies $\frac{1}{R_a} \leq 0.055 \leq \frac{1}{R_b}$, thus providing a dissipative coupling locally. Also, with these set of parameters the circuit has a unique unstable equilibrium. The simulated behavior is bounded and entirely in the active range of the controlled resistors. By 2-dominance of the circuit, the trajectory must converge to a limit cycle according to Theorem 5.

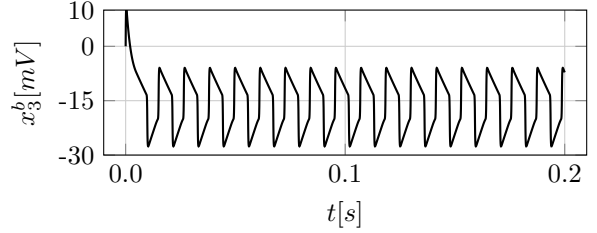

Fig. 9. Time trajectory of the voltage across the capacitor C_3 of the circuit in Figure 8.

7 Conclusions

We presented a methodology for the global analysis of nonlinear circuits obtained as the physical interconnection of conventional linear elements and negative resistors. We identified two families of circuits sorted by its signature in the supply rate and provided simple coupling mechanisms for connections of circuits with opposite signature. Future work will investigate the extension of the theory to general physical systems and a larger class of nonlinear elements including nonlinear capacitors, nonlinear inductors, and memristors. Such a theory would find a direct application in the design of neuromorphic systems that assemble large collections of switching and spiking elements as in [8], [30].

References

- [1] B. D. O. Anderson and S. Vongpanitlerd. *Network Analysis and Synthesis: A modern systems theory approach*. Dover Publications, 2006.
- [2] D. Angeli. A Lyapunov approach to incremental stability properties. *IEEE Transactions on Automatic Control*, 47(3):410–421, 2002.
- [3] C. Bowick. *RF circuit design*. Newnes, 1982.
- [4] S. Boyd, L.E. Ghaoui, E. Feron, and V. Balakrishnan. *Linear Matrix Inequalities in System and Control Theory*. Studies in Applied Mathematics. SIAM, 1994.
- [5] R. K. Brayton and J. K. Moser. A theory of nonlinear networks. I. *Quarterly of Applied Mathematics*, 22(1):1–33, 1964.
- [6] B. Brogliato, R. Lozano, B. Maschke, and O. Egeand. *Dissipative Systems Analysis and Control: Theory and Applications*. Communications and Control Engineering. Springer Verlag London, 2nd edition, 2007.
- [7] M. K. Camlibel, W. P. M. H. Heemels, and J. M. Schumacher. On linear passive complementarity systems. *European Journal of Control*, 8(3):220–237, 2002.
- [8] F. Castaños and A. Franci. Implementing robust neuromodulation in neuromorphic circuits. *Neurocomputing*, 233:3–13, 2017.
- [9] S.-L. Chen, P. B. Griffin, and J. D. Plummer. Negative differential resistance circuit design and memory applications. *IEEE Transactions on Electron Devices*, 56(4):634–640, 2009.
- [10] L. O. Chua. Dynamic nonlinear networks: state-of-the-art. *IEEE Transactions on Circuits and Systems*, 27(11):1059–1087, 1980.
- [11] L. O. Chua, C. A. Desoer, and E. S. Kuh. *Linear and nonlinear circuits*. Mc-Graw Hill, 1987.
- [12] L. O. Chua, J. Yu, and Y. Yu. Negative resistance devices. *Circuit Theory and Applications*, 11:161–186, 1983.
- [13] C. A. Desoer and M. Vidyasagar. *Feedback Systems: Input–Output Properties*. Society for Industrial and Applied Mathematics, 2009.
- [14] F. Forni and R. Sepulchre. A differential Lyapunov framework for contraction analysis. *IEEE Transactions on Automatic Control*, 59(3):614–628, 2014.
- [15] F. Forni and R. Sepulchre. A dissipativity theorem for p -dominant systems. In *Decision and Control, 56th IEEE Conference on*, Melbourne, Australia, December 2017.
- [16] F. Forni and R. Sepulchre. Differential dissipativity theory for dominance analysis. *IEEE Transactions on Automatic Control*, 64(6), 2019.
- [17] F. Forni, R. Sepulchre, and A. J. van der Schaft. On differential passivity of physical systems. In *Decision and Control, 52nd IEEE Conference on*, pages 6580–6585, Florence, Italy, Dec 2013.
- [18] E. Goto, K. Murata, K. Nakazawa, K. Nakagawa, T. Moto-Oka, Y. Matsuoka, Y. Ishibashi, H. Ishida, T. Soma, and E. Wada. Esaki diode high speed logical circuits. *IRE Transactions on electronic computers*, EC-9(1):25–29, 1960.
- [19] D. J. Hill and P. J. Moylan. Dissipative dynamical systems: basic input-output and state properties. *Journal of the Franklin Institute*, 309(5):327–357, 1980.
- [20] C.-L. J. Hu. Self-sustained oscillation in an $R_H - C$ or $R_H - L$ circuit containing a hysteresis resistor R_H . *IEEE Transactions on Circuits and Systems*, CAS-33(6):636–641, 1986.
- [21] R. M. Kaplan. Equivalent circuits for negative resistance devices. Technical report, Rome Air Development Center, Griffiss Air Force Base NY, 1968.
- [22] M. P. Kennedy. Three steps to chaos - Part I: Evolution. *IEEE Transactions on Circuits and Systems - I*, 40(10):640–656, 1993.
- [23] M. P. Kennedy and L. O. Chua. Hysteresis in electronic circuits: a circuit theorist’s perspective. *International Journal of Circuit Theory and Applications*, 19:471–515, 1991.
- [24] D. Li and Y. Tsvividis. Active LC filters on silicon. In *IEE Proceedings - Circuits, Devices and Systems*, volume 147, pages 49–56, 2000.
- [25] W. Lohmiller and J.-J. E. Slotine. On contraction analysis for nonlinear systems. *Automatica*, 34(6):683–696, 1998.
- [26] F. A. Miranda-Villatoro, F. Forni, and R. Sepulchre. Dominance analysis of linear complementarity systems. In *23rd International Symposium on Mathematical Theory of Networks and Systems*, pages 422–428, Hong Kong, July 2018.
- [27] J. Nagumo, S. Arimoto, and S. Yoshizawa. An active pulse transmission line simulating a nerve axon. *Proceedings of the IRE*, 50(10):2061–2070, 1962.
- [28] R. Ortega, A. Loría, P. J. Nicklasoon, and H. Sira-Ramírez. *Passivity-based Control of Euler-Lagrange Systems: Mechanical, Electrical and Electromechanical Applications*. Communications and Control Engineering. Springer, 1998.
- [29] A. V. Proskurnikov, F. Zhang, M. Cao, and J. M. A. Scherpen. A general criterion for synchronization of incrementally dissipative nonlinearly coupled agents. In *2015 European Control Conference (ECC)*, pages 581–586, Linz, Austria, July 2015.
- [30] L. Ribar and R. Sepulchre. Neuromodulation of neuromorphic circuits. *IEEE Transactions on Circuits and Systems I: Regular Papers*, 66(8):3028–3040, 2019.
- [31] T. Saito and S. Nakagawa. Chaos from a hysteresis and switched circuit. *Philosophical Transactions of the Royal Society of London. Series A: Physical and Engineering Sciences*, 353(1701):47–57, 1995.
- [32] R. Sepulchre, M. Jankovic, and P. V. Kokotovic. *Constructive Nonlinear Control*. Springer-Verlag, London, 1997.
- [33] G. B. Stan and R. Sepulchre. Analysis of interconnected oscillators by dissipativity theory. *IEEE Transactions on Automatic Control*, 52(2):256–270, 2007.
- [34] B. Van der Pol. On relaxation oscillations. *The London, Edinburgh, and Dublin Philosophical Magazine and Journal of Science*, 2(11):978–992, 1926.
- [35] A. J. van der Schaft. *L2 - Gain and Passivity Techniques in Nonlinear Control*. Communications and Control Engineering. Springer London, second edition, 2010.
- [36] A. J. van der Schaft. On differential passivity. In *9th Symposium on Nonlinear Control Systems*, pages 21–25, Toulouse, France, September 2013.
- [37] J. C. Willems. Dissipative dynamical systems part I: General theory. *Archive for rational mechanics and analysis*, 45(5):321–351, 1972.
- [38] J. C. Willems. Dissipative dynamical systems part II: Linear systems with quadratic supply rates. *Archive for rational mechanics and analysis*, 45(5):352–393, 1972.