



**HAL**  
open science

# On Proper Labellings of Graphs with Minimum Label Sum

Julien Bensmail, Foivos Fioravantes, Nicolas Nisse

► **To cite this version:**

Julien Bensmail, Foivos Fioravantes, Nicolas Nisse. On Proper Labellings of Graphs with Minimum Label Sum. *Algorithmica*, 2022, 84 (4), pp.1030-1063. 10.1007/s00453-021-00903-x . hal-03455908

**HAL Id: hal-03455908**

**<https://hal.science/hal-03455908>**

Submitted on 29 Nov 2021

**HAL** is a multi-disciplinary open access archive for the deposit and dissemination of scientific research documents, whether they are published or not. The documents may come from teaching and research institutions in France or abroad, or from public or private research centers.

L'archive ouverte pluridisciplinaire **HAL**, est destinée au dépôt et à la diffusion de documents scientifiques de niveau recherche, publiés ou non, émanant des établissements d'enseignement et de recherche français ou étrangers, des laboratoires publics ou privés.

# On Proper Labellings of Graphs with Minimum Label Sum

Julien Bensmail, Foivos Fioravantes\*, Nicolas Nisse†  
foivos.fioravantes@inria.fr

November 29, 2021

## Abstract

The 1-2-3 Conjecture, raised by Karoński, Łuczak and Thomason, states that almost every graph  $G$  admits a proper 3-labelling, i.e., a labelling of the edges with 1, 2, 3 such that no two adjacent vertices are incident to the same sum of labels. Another interpretation of this conjecture, that may be attributed to Chartrand et al., is that almost every graph  $G$  can be turned into a locally irregular multigraph  $M$ , i.e., with no two adjacent vertices having the same degree, by replacing each of its edges by at most three parallel edges. In other words, for almost every graph  $G$  there should be a locally irregular multigraph  $M$  with the same adjacencies and having a relatively small number of edges. The 1-2-3 Conjecture, if true, would indeed imply that there is such an  $M$  with  $|E(M)| \leq 3|E(G)|$ .

In this work, we study proper labellings of graphs with the extra requirement that the sum of assigned labels must be as small as possible. In other words, given a graph  $G$ , we are looking for a locally irregular multigraph  $M^*$  with the smallest number of edges possible that can be obtained from  $G$  by multiplying edges. This problem is actually quite different from the 1-2-3 Conjecture, as we prove that there is no absolute constant  $k$  such that  $M^*$  can always be obtained from  $G$  by replacing each edge with at most  $k$  parallel edges.

We investigate several aspects of this problem, covering algorithmic and combinatorial aspects. In particular, we prove that the problem of designing proper labellings with minimum label sum is  $\mathcal{NP}$ -hard in general, but solvable in polynomial time for graphs with bounded treewidth. We also conjecture that for almost every connected graph  $G$  there should be a proper labelling with label sum at most  $2|E(G)|$ , which we verify for several classes of graphs.

## 1 Introduction

In this work we study properties of some **distinguishing labellings** of graphs. We begin by giving some useful definitions and notations. Let  $G = (V, E)$  be a graph. Throughout this work, most of the time we denote by  $V$  and  $E$  the vertex set and edge set of a given graph. In a few cases where ambiguities are possible, we instead denote these sets by  $V(G)$  and  $E(G)$ . For a vertex  $v \in V$  of  $G$ , we denote by  $d(v)$  the degree of  $v$ , that is the number of edges that are incident to  $v$ . We say that  $G$  is *regular* if for each  $u, v \in V$ , we have  $d(u) = d(v)$ . It is well known that there exists no non-trivial simple graph that is *totally irregular*, meaning a simple graph for which all vertices have different degrees. This however is not true for multigraphs, where multiple edges between two adjacent vertices are allowed. A graph  $G$  is called *locally irregular* if for each  $uv \in E$ , we have  $d(u) \neq d(v)$ . For any additional notation on graph theory not defined here, we refer the reader to [11].

A function  $\ell : E \mapsto \{1, \dots, k\}$  is called a  $k$ -labelling of  $G$ . By a *distinguishing labelling* we mean a labelling  $\ell$  that allows us to distinguish the vertices of  $G$  accord to some vertex parameter computed from  $\ell$ . Note that this can equivalently be seen through the scope of graph colouring. In this work, we are more particularly interested in **proper labellings**, which are defined as follows. For any  $v \in V$ , let us denote by  $c_\ell(v)$  the *colour* of  $v$  that is induced by  $\ell$ , being the sum of labels

---

\*Corresponding author

†Université Côte d'Azur, CNRS, Inria, I3S, France

assigned to the edges incident to  $v$ . That is,

$$c_\ell(v) = \sum_{u \in N(v)} \ell(vu),$$

where  $N(v) = \{u \in V : uv \in E\}$  is the neighbourhood of  $v$ . We say that  $\ell$  is *proper* if the resulting  $c_\ell$  is a proper vertex-colouring of  $G$ , i.e., for every edge  $uv \in E$  we have  $c_\ell(u) \neq c_\ell(v)$ . Note that a graph admits a proper labelling if and only if it has no  $K_2$  as a component [14]. Therefore, we here focus only on *nice graphs*, i.e., graphs without any component isomorphic to  $K_2$ . It is clear that for every (not necessarily proper) labelling  $\ell$  of  $G$  and for every  $v \in V$ , we have  $c_\ell(v) \geq d(v)$  with  $c_\ell(v) = d(v)$  if and only if all edges incident to  $v$  are assigned label 1. It follows that  $G$  admits a proper 1-labelling if and only if  $G$  is locally irregular.

The connection between the labellings of a graph  $G$  and its “regularity” has been explored by several authors, in particular through the notion of **irregularity strength** of graphs, introduced by Chartrand et al. in [10]. The *irregularity strength*  $s(G)$  of  $G$  is defined as the smallest  $k$  such that  $G$  admits a  $k$ -labelling  $\ell$  with the property that for every two  $u, v \in V$  (not necessarily adjacent), we have  $c_\ell(u) \neq c_\ell(v)$ . The main point for studying such labellings  $\ell$ , is that if, from  $G$ , we replace each edge  $e$  by  $\ell(e)$  parallel edges, then we get a multigraph  $M$  that is totally irregular. Note that building  $M$  in this way preserves the adjacencies of  $G$ , that is  $M$  has the same structure as  $G$ . As stated earlier, no non-trivial simple graph  $G$  is totally irregular; it is thus legitimate to wonder how to build a corresponding totally irregular multigraph  $M$  in the fashion above. In their work, Chartrand et al. regard edge multiplications as an expensive operation and, as such, they want to limit it as much as possible. This results in the following optimisation problem: for a given graph  $G$ , what is the smallest  $k$  such that  $G$  can be turned into a totally irregular multigraph  $M$  by replacing each edge with at most  $k$  parallel edges? From the labelling point of view, this smallest  $k$  is precisely  $s(G)$ .

Since the notion of total irregularity does not fit with simple graphs, as  $K_1$  is the only totally irregular simple graph, it is legitimate to consider that this notion is too strong for simple graphs, and instead consider weaker notions of irregularity. A few such notions have been explored in the literature, such as the notions of highly irregular graphs [9] or locally irregular graphs [2], which we introduced earlier. With respect to Chartrand et al.’s point of view, we note that there is again a straight connection between proper labellings and locally irregular graphs. Namely, given a proper labelling  $\ell$  of a graph  $G$ , by replacing each edge  $e$  with  $\ell(e)$  parallel edges, we get a locally irregular multigraph  $M$  with the same structure as  $G$ . As in the previous problem, one can again ask about the smallest  $k$  such that  $G$  admits proper  $k$ -labellings. This smallest  $k$  (if any) is denoted  $\chi_\Sigma(G)$ .

This parameter  $\chi_\Sigma$  is precisely at the heart of one of the most famous conjectures concerning proper labellings of graphs, the so-called **1-2-3 Conjecture**, introduced by Karoński, Łuczak and Thomason in 2004 [14]. This conjecture states that for every nice graph  $G$ , we have  $\chi_\Sigma(G) \leq 3$ . It is worth noting that there exist nice graphs  $G$  that verify  $\chi_\Sigma(G) = 3$  (for example every nice complete graph  $K_n$  has  $\chi_\Sigma(K_n) = 3$  as shown in [8]) and thus it is meaningless to try to show that  $\chi_\Sigma(G) \leq 2$  holds for all graphs  $G$ . There are many results supporting the 1-2-3 Conjecture, the most famous of which belonging to Kalkowski, Karoński and Pfender [13], stating that for any nice graph  $G$ , we have  $\chi_\Sigma(G) \leq 5$ . Another important result shown in [14] states that the 1-2-3 Conjecture holds for nice 3-colourable graphs. However, unless a graph  $G$  is locally irregular (in which case  $\chi_\Sigma(G) = 1$ ), it is not easy in general to characterise which graphs  $G$  have  $\chi_\Sigma(G) = 2$  (see [12]). Nevertheless, a “good” characterisation of nice bipartite graphs  $G$  with  $\chi_\Sigma(G) = 3$ , was provided quite recently in [20].

Minimising, however, the maximum label that is used to create a proper labelling of a graph  $G$ , does not always guarantee that we have actually minimised the cost that corresponds to the edge multiplications described above. For example, a 2-labelling  $\ell$  that assigns label 2 to three edges of  $G$  and label 1 to the rest is more expensive (in terms of how many edges the corresponding multigraphs have) than a 3-labelling  $\ell'$  that assigns label 3 to only one edge of  $G$  and label 1 to the rest. The 1-2-3 Conjecture, if true, would imply that every nice graph  $G$  admits a proper labelling where the sum of assigned labels is at most  $3|E|$ ; but it might be that, using labels with value larger than 3, we can design better (with respect to the concerns above) proper labellings of  $G$ .

This motivates us to introduce and study a new problem, namely the problem of finding proper labellings that minimise the sum of the assigned labels.

Formally, for a labelling  $\ell$  of a graph  $G$ , we denote by  $\sigma(\ell)$  the sum of labels assigned to the edges of  $G$  by  $\ell$ . That is,

$$\sigma(\ell) = \sum_{e \in E} \ell(e).$$

For any  $k \geq 1$ , we denote by  $\text{mE}_k(G)$  the minimum value of  $\sigma(\ell)$  over all  $k$ -labellings  $\ell$  of  $G$  (if any). That is,

$$\text{mE}_k(G) = \min \{ \sigma(\ell) : \ell \text{ is a } k\text{-labelling of } G \}.$$

We set  $\text{mE}(G) = \min \{ \text{mE}_k(G) : k \geq \chi_\Sigma(G) \}$ .

The study of the parameter  $\text{mE}(G)$  takes place in a recent series of works dedicated to better understanding the connection between proper labellings and proper vertex-colourings of graphs. In [1], the authors studied proper vertex-colourings of graphs that minimise the number of distinct resulting colours. In other words, the authors are interested by proper labellings by which the number of distinct resulting vertex colours is as close as possible to the chromatic number. Noticing that this minimum number of distinct colours by a proper labelling is bounded above by the minimum maximum vertex colour that can be achieved by a proper labelling, in [5] the authors studied proper labellings where the maximum resulting vertex colour is as small as possible. In these two works, the authors mainly showed that finding an ‘‘optimal’’ proper labelling is hard in general but easy in particular graph classes, and provided results towards conjectures they have raised on their modified notions of proper labellings.

An important point for mentioning the existence of [1] and [5] is that determining  $\text{mE}(G)$  for a given graph  $G$  is also related to finding a proper labelling of  $G$  where the resulting vertex colours satisfy some properties. More precisely, by a straight equivalence between edge labels and vertex colours, see upcoming Observation 2.2, it can be established that determining  $\text{mE}(G)$  is equivalent to finding a proper labelling of  $G$  that minimises the sum of resulting vertex colours. Thus, at least at first glance, one could think that determining  $\text{mE}(G)$  is somewhat related to the investigations in [1] and [5]. In Section 4.1, we actually show that this is not the case, in the sense that proper labellings that are good for our concerns might be arbitrarily bad for those in [1] and [5], and *vice versa*.

## Our contributions<sup>1</sup>

In Section 2 we provide some observations that will be used throughout this work. As a warm up, we also provide the exact value of  $\text{mE}(G)$  for easy classes of graphs  $G$ , namely complete bipartite graphs, complete graphs and cycles.

In Section 3 we deal with the algorithmic aspects of the problem. We show that for  $k \in \mathbb{N}$ , determining  $\text{mE}_k(G)$  is  $\mathcal{NP}$ -complete when  $G$  is a planar bipartite graph. Then we provide an algorithm that, given two integers  $s$  and  $k$ , decides in polynomial time if  $\text{mE}_k(G) \leq s$  when  $G$  belongs to the family of graphs that have bounded treewidth.

In Section 4 we answer two different questions that deal with the particular nature of our problem. First, in Section 4.1, we show that in general a proper  $k$ -labelling that minimises the maximum induced colour does not minimise the sum of the labels used, and *vice versa*. Then, in Section 4.2, we provide an infinite family of graphs  $G$  for which  $\text{mE}_k(G)$ , for every  $k \geq 2$ , can be arbitrarily larger than  $\text{mE}_{k+1}(G)$ . As mentioned earlier, this property justifies the study of our problem, as it shows that just finding a proper  $k$ -labelling of  $G$  for  $k = \chi_\Sigma(G)$  is not enough.

Finally, in Section 5 we study more general aspects of the problem. In particular we propose Conjecture 5.2 stating that for every nice connected graph  $G$ , we should have  $\text{mE}(G) \leq 2|E|$ . We then proceed by providing upper bounds for some families of graphs, namely bipartite graphs and trees, as well as graphs with large chromatic number, that further strengthen our belief that Conjecture 5.2 should hold true.

---

<sup>1</sup>An extended abstract of this paper has been accepted in the proceedings of the 31st International Workshop on Combinatorial Algorithms (IWOCA 2020) [4].

## 2 First observations and classes of graphs

In this warm-up section, we give some first insight into the problem of determining the parameters  $\text{mE}(G)$  and  $\text{mE}_k(G)$  for a given graph  $G$ . This is done through first observations on the problem, and by then focusing on easy classes of graphs.

### 2.1 First observations and remarks

The following observation provides trivial bounds on  $\sigma(\ell)$  for a  $k$ -labelling  $\ell$ .

**Observation 2.1.** *Let  $G$  be a graph and  $\ell$  be a  $k$ -labelling of  $G$ . Then*

$$|E| \leq \sigma(\ell) \leq k|E|.$$

Consequently, for any  $k \geq \chi_\Sigma(G)$ , we have

$$|E| \leq \text{mE}_k(G) \leq k|E|.$$

The following provides an obvious way for relating edge labels and vertex colours by a labelling of a graph  $G$ , that, in general, is a convenient tool for establishing lower bounds on  $\text{mE}(G)$ .

**Observation 2.2.** *Let  $G$  be a graph and  $\ell$  be a labelling of  $G$ . Then*

$$\sum_{e \in E} 2\ell(e) = \sum_{v \in V} c_\ell(v).$$

In particular, by any labelling  $\ell$ , the sum  $\sum_{v \in V} c_\ell(v)$  must be an even number.

In several contexts, we will make use of the following property of proper labellings in graphs having some particular sparse structure (adjacent degree-2 vertices):

**Observation 2.3.** *Let  $G$  be a graph with a path  $(v_1, v_2, v_3, v_4)$  such that  $d(v_2) = d(v_3) = 2$ . Then, by any proper labelling  $\ell$  of  $G$ , we have  $\ell(v_1v_2) \neq \ell(v_3v_4)$ .*

*Proof.* This is because  $c_\ell(v_2) = \ell(v_1v_2) + \ell(v_2v_3)$  and  $c_\ell(v_3) = \ell(v_2v_3) + \ell(v_3v_4)$ . This implies we must have  $\ell(v_1v_2) \neq \ell(v_3v_4)$  so that  $c_\ell(v_2) \neq c_\ell(v_3)$ .  $\square$

### 2.2 Easy classes of graphs

In this section, we determine the value of  $\text{mE}(G)$  when  $G$  is any nice complete bipartite graph, complete graph, or cycle. Let us recall that, for any nice complete bipartite graph  $K_{n,m}$ , we have  $\chi_\Sigma(K_{n,m}) = 1$  if  $n \neq m > 1$ , and  $\chi_\Sigma(K_{n,m}) = 2$  otherwise. For every nice complete graph  $K_n$ , we have  $\chi_\Sigma(K_n) = 3$ . For every nice cycle  $C_n$ , we have  $\chi_\Sigma(C_n) = 3$  whenever  $n \geq 3$  is odd or  $n \equiv 2 \pmod{4}$ , while we have  $\chi_\Sigma(C_n) = 2$  otherwise, i.e., when  $n \equiv 0 \pmod{4}$ . Simple proofs for these statements can be found e.g. in [8].

Note that in all the results obtained in this section, constructing a proper labelling  $\ell$  of a graph  $G$  achieving  $\sigma(\ell) = \text{mE}(G)$  does not require the use of a label larger than  $\chi_\Sigma(G)$ . That is, we here always have  $\text{mE}_k(G) = \text{mE}(G)$  for  $k = \chi_\Sigma(G)$ . It is important to point out however that this behaviour is not true in general (see Section 4.2).

**Theorem 2.4.** *Let  $G = (A, B, E) = K_{n,m}$  be a complete bipartite graph with  $n + m > 2$ . Then:*

- if  $n \neq m$ , then  $\text{mE}(G) = \text{mE}_1(G) = nm = |E|$ ;
- otherwise, i.e.,  $n = m$ , we have  $\text{mE}(G) = \text{mE}_2(G) = n(m + 1) = |E| + \sqrt{|E|}$ .

*Proof.* If  $n \neq m$ , then  $G$  is locally irregular, in which case we get a proper 1-labelling when assigning label 1 to all edges. This is best possible due to Observation 2.1. If  $n = m$ , then  $G$  is not locally irregular, which implies that a proper labelling of  $G$  must assign a label different from 1 to some edges. Moreover, if a labelling assigns a label different than 1 to less than  $n$  edges, then there would

necessarily be, in both  $A$  and  $B$ , vertices incident only to edges labelled 1, thus with colour  $n$ . In that case,  $\ell$  would not be proper as some adjacent vertices would have the same colour.

This means that if  $n = m$ , a proper labelling  $\ell$  of  $G$  must assign a label different from 1 to at least  $n$  edges. This implies that  $\text{mE}_k(G) \geq |E| + n$ . We claim there is a proper 2-labelling  $\ell$  achieving this lower bound, hence best possible. To obtain  $\ell$ , let  $a$  be any vertex of  $A$ . Assign label 2 to all the  $n$  edges incident to  $a$ , and assign label 1 to all other edges. This labelling is proper. Indeed  $c_\ell(a) = 2n$ ,  $c_\ell(a') = n$  for every  $a' \in A \setminus \{a\}$ , and  $c_\ell(b) = n + 1$  for every  $b \in B$ . Furthermore,  $\sigma(\ell) = |E| + n = |E| + \sqrt{|E|}$ .  $\square$

**Theorem 2.5.** *Let  $K_n$  be a complete graph with  $n \geq 3$ . Then:*

- if  $n = 3$ , then  $\text{mE}(K_3) = \text{mE}_3(K_3) = 6 = 2|E|$ ;
- if  $n \equiv 0 \pmod{4}$  or  $n \equiv 1 \pmod{4}$ , then  $\text{mE}(K_n) = \text{mE}_3(K_n) = \frac{1}{2} \left( n^2 + \frac{(n-2)(n-1)}{2} - 1 \right) = \frac{3}{2}|E|$ ;
- if  $n \equiv 2 \pmod{4}$  or  $n \equiv 3 \pmod{4}$ , then  $\text{mE}(K_n) = \text{mE}_3(K_n) = \frac{1}{2} \left( n^2 + \frac{(n-2)(n-1)}{2} \right) = \lceil \frac{3}{2}|E| \rceil$ .

*Proof.* Throughout this proof, for any  $n \geq 3$ , let  $V = \{v_1, \dots, v_n\}$ .

Regarding the first item, Observation 2.3 implies that a proper 3-labelling of  $K_3$  must assign three distinct labels to the edges, and thus having  $\{\ell(v_1v_2), \ell(v_1v_3), \ell(v_2v_3)\} = \{1, 2, 3\}$  is optimal, in which case  $\sigma(\ell) = 6$ .

Let us now focus on the second and third items. Following Observation 2.2, finding a proper 3-labelling of  $K_n$  achieving  $\text{mE}_3(K_n)$  is equivalent to finding a proper 3-labelling minimising the sum of vertex colours. Since, in  $K_n$ , all vertices have degree  $n - 1$ , and all vertex colours must be different by a proper 3-labelling, any proper 3-labelling producing distinct vertex colours in  $S_1 = \{n - 1, n, n + 1, \dots, 2n - 2\}$  would be optimal. Note, however, that when  $n$  is congruent to 2 or 3 modulo 4, such a proper 3-labelling cannot exist as, in such cases, the sum  $n - 1 + n + (n + 1) + \dots + (2n - 2)$  of the values in  $S_1$  is odd, which cannot be achieved by a labelling (recall the last statement of Observation 2.2). In these cases, however, any proper labelling producing distinct vertex colours in  $S_2 = \{n - 1, n, n + 1, \dots, 2n - 3, 2n - 1\}$  would be optimal.

Now consider the following 3-labelling  $\ell$  of  $K_n$  ( $n \geq 4$ ), already introduced in [5], to establish what the value of  $\text{mS}_3(K_n)$  is (where  $\text{mS}_3(G)$  denotes the smallest maximum color over the vertices by a proper 3-labelling of  $G$ ). We label the edges of  $K_n$  through three steps. Firstly, we assign label 1 to every edge. Secondly, we change the labels of the edges in  $\{v_iv_j : 1 \leq i, j \leq n, i + j \geq n + 2\}$  to 2. Then  $v_1$  is incident to no edge labelled 2, vertex  $v_2$  is incident to one edge labelled 2, vertex  $v_i$  for  $3 \leq i \leq \lfloor (n - 1)/2 \rfloor + 1$  is incident to  $i - 1$  edges labelled 2, and  $v_i$  for  $\lfloor (n - 1)/2 \rfloor + 2 \leq i \leq n$  is incident to  $i - 2$  edges labelled 2. Let  $j = \lfloor (n - 1)/2 \rfloor + 1$ . Note that for every  $i \in \{2, 3, \dots, j, j + 2, \dots, n\}$ ,  $v_i$  is adjacent to one more edge labelled 2 than  $v_{i-1}$ ; and that  $v_j$  and  $v_{j+1}$  are both adjacent to  $j - 1$  edges labelled 2 (and  $n - j$  edges labelled 1). So  $c_\ell(v_1) < c_\ell(v_2) < \dots < c_\ell(v_j) = c_\ell(v_{j+1}) < c_\ell(v_{j+2}) < \dots < c_\ell(v_n)$  and  $c_\ell(v_{i+1}) \leq c_\ell(v_i) + 1$  for  $1 \leq i \leq n$ , i.e., all vertices have different colours except  $v_j$  and  $v_{j+1}$ . Finally, to avoid the conflict between  $v_j$  and  $v_{j+1}$ , let us increase the label of  $v_{j+1}v_{j+2}$  from 2 to 3. This change induces a new conflict between  $v_{j+2}$  and  $v_{j+3}$ . Then we need to increase the label of  $v_{j+3}v_{j+4}$  from 2 to 3 to get rid of this conflict, which creates a new conflict, and so on. Formally, we change the labels of the edges in  $\{v_{j+1}v_{j+2}, v_{j+3}v_{j+4}, \dots, v_{n-1}v_n\}$  to 3 if  $n - j$  is even, i.e., if  $n \equiv 0 \pmod{4}$  or  $n \equiv 1 \pmod{4}$ . Otherwise, if  $n - j$  is odd and  $n \equiv 2 \pmod{4}$  or  $n \equiv 3 \pmod{4}$ , then we change the labels of the edges in  $\{v_{j+1}v_{j+2}, v_{j+3}v_{j+4}, \dots, v_{n-4}v_{n-3}, v_{n-2}v_n, v_{n-1}v_n\}$  to 3.

It can be checked that the resulting 3-labelling  $\ell$  is proper, and achieves vertex colours in  $S_1$  when  $n$  is congruent to 0 or 1 modulo 4, or vertex colours in  $S_2$  when  $n$  is congruent to 2 or 3 modulo 4. As discussed above, this is best possible. Furthermore, it can easily be checked that the elements in  $S_1$  sum up to the value claimed in the second item, and similarly for the elements in  $S_2$  and the value claimed in the third item. This concludes the proof.  $\square$

**Theorem 2.6.** *Let  $n \geq 3$ , and  $C_n$  be the cycle of length  $n$ . Then:*

- if  $n \equiv 0 \pmod{4}$ , then  $\text{mE}(C_n) = \text{mE}_2(C_n) = \frac{3}{2}|E|$ ;

- if  $n \equiv 1 \pmod{4}$  or  $n \equiv 3 \pmod{4}$ , then  $\text{mE}(C_n) = \text{mE}_3(C_n) = \lceil \frac{3}{2}|E| \rceil + 1$ ;
- if  $n \equiv 2 \pmod{4}$ , then  $\text{mE}(C_n) = \text{mE}_3(C_n) = \frac{3}{2}|E| + 3$ .

*Proof.* Let us order the edges of  $C_n$  following a “clockwise direction” and define  $E = \{e_1, \dots, e_n\}$  and  $V = \{v_1, \dots, v_n\}$  such that for  $i < n$ ,  $e_i = v_i v_{i+1}$  and  $e_n = v_n v_1$ . Thus, for  $i > 0$ ,  $N(v_i) = \{v_{i-1}, v_{i+1}\}$  and  $N(v_1) = \{v_2, v_n\}$ . Recall that  $\chi_\Sigma(C_n) = 2$  for the first item and that  $\chi_\Sigma(C_n) = 3$  for the second and third items.

**Claim 2.7.** *Let  $l \leq k$  and  $\ell$  be a  $k$ -labelling of  $C_n$  that assigns label  $l$  to at least one edge. If  $\ell$  is proper, then it assigns label  $l$  to at most  $\lfloor \frac{1}{2}|E| \rfloor$  edges if  $n$  is odd, while it assigns label  $l$  to at most  $\frac{1}{2}|E| - 1$  edges if  $n \equiv 2 \pmod{4}$ , and it assigns label  $l$  to at most  $\frac{1}{2}|E|$  edges if  $n \equiv 0 \pmod{4}$ .*

*Proof of the claim.* Let  $\mathcal{E} = \{e \in E : \ell(e) = l\}$  and  $G = (V', E')$  be the graph that has  $V' = \{v_i : e_i \in \mathcal{E}\}$  and, for  $i \neq j$ ,  $v_i v_j \in E'$  if the corresponding edges  $e_i, e_j$  are at distance exactly 2 in  $C_n$ . Obviously  $|E| = |V'|$ . It follows from Observation 2.3 that if  $\ell$  is a proper labelling of  $C_n$  that maximises  $|\mathcal{E}|$ , then  $|\mathcal{E}| = |S|$ , where  $S$  is an independent set of  $G$ . For  $n$  odd,  $G$  is a copy of the graph  $C_n$ . Since  $G$  is a cycle,  $|\mathcal{E}| = |S| = \lfloor \frac{1}{2}|V'| \rfloor = \lfloor \frac{1}{2}|E| \rfloor$ . For  $n \equiv 2 \pmod{4}$ , let  $m$  be such that  $n = 4m + 2$ . It is clear that  $G$  contains two connected components, each one being a copy of the  $C_{\frac{n}{2}}$  cycle. Thus,  $|\mathcal{E}| = |S| = 2 \lfloor \frac{n}{4} \rfloor = 2m = \frac{1}{2}|E| - 1$ . Similarly, if  $n = 4m$ , it is clear that  $G$  contains two connected components, each one being a copy of the  $C_{\frac{n}{2}}$  cycle. Thus,  $|\mathcal{E}| = |S| = 2m = \frac{1}{2}|E|$ .  $\diamond$

We are now ready to deal with the four values of  $n$  (modulo 4) separately:

- For the first item let  $\ell$  be the following 2-labelling:  $\ell(e_1) = 1, \ell(e_2) = 1, \ell(e_3) = 2, \ell(e_4) = 2, \ell(e_5) = 1, \dots, \ell(e_n) = 2$ . Let us assume that this  $\ell$  is not proper. Then there would exist at least two adjacent vertices  $v_i, v_{i+1}$  such that  $c_\ell(v_i) = c_\ell(v_{i+1})$ . It follows that  $\ell(v_{i-1}) = \ell(v_{i+2})$  (if  $i = 1$  then  $v_{i-1} = v_n$  and if  $i = n$  then  $v_{i+1} = v_1$ ) which is a contradiction. Furthermore, since  $n \equiv 0 \pmod{4}$ , label 2 is used on exactly half the edges of  $C_n$  and thus  $\sigma(\ell) = |E| + \frac{1}{2}|E| = \frac{3}{2}|E|$ . Moreover, this value is optimal. Indeed, assume it is not. Then, there would exist a proper labelling  $\ell'$  such that more than  $\frac{1}{2}|E|$  edges are labelled 1 by  $\ell'$ , a contradiction by Claim 2.7.
- Let  $C_n$  be a cycle with  $n \equiv 1 \pmod{4}$ . We will show that  $\text{mE}(C_n) = \lceil \frac{3}{2}|E| \rceil + 1$ . Let  $\ell$  be a proper labelling of  $C_n$  that assigns label 3 to only one edge. It follows from Claim 2.7 that at most  $\lfloor \frac{n}{2} \rfloor$  edges of  $C_n$  are labelled 1. Actually, there are exactly  $\lfloor \frac{n}{2} \rfloor$  edges labelled 1: if this was not the case, then, since only one edge of  $C_n$  is labelled 3, there would be more than  $\lfloor \frac{n}{2} \rfloor$  edges labelled 2, contradicting Claim 2.7. The same holds true for the edges labelled 2. Since  $n \equiv 1 \pmod{4}$  implies that there exists an  $m$  verifying  $n = 4m + 1$ , then, using this, one can easily show that  $\sigma(\ell) = \lfloor \frac{n}{2} \rfloor + 2 \lfloor \frac{n}{2} \rfloor + 3 = \dots = \lceil \frac{3}{2}|E| \rceil + 1$ . Furthermore, let  $\ell'$  be a proper labelling of  $C_n$  that assigns label 3 to more than one edge. It is clear that if  $\ell'$  is proper, then  $\sigma(\ell) < \sigma(\ell')$ . Thus,  $\sigma(\ell) = \text{mE}(C_n)$ . The following is a proper labelling  $\ell$  that achieves this optimal value:  $\ell(e_1) = 1, \ell(e_2) = 1, \ell(e_3) = 2, \ell(e_4) = 2, \ell(e_5) = 1, \dots, \ell(e_{n-1}) = 2, \ell(e_n) = 3$ .
- Let  $C_n$  be a cycle with  $n \equiv 3 \pmod{4}$ . Similarly to before,  $\text{mE}(C_n) = \lceil \frac{3}{2}|E| \rceil + 1$ . The following is a proper labelling  $\ell$  that achieves this optimal value:  $\ell(e_1) = 1, \ell(e_2) = 1, \ell(e_3) = 2, \ell(e_4) = 2, \ell(e_5) = 1, \dots, \ell(e_{n-3}) = 2, \ell(e_{n-2}) = 1, \ell(e_{n-1}) = 3, \ell(e_n) = 2$ .
- Let  $C_n$  be a cycle with  $n \equiv 2 \pmod{4}$  ( $n \geq 6$ ). We will show that  $\text{mE}(C_n) = \frac{3}{2}|E| + 3$ . Indeed, let  $\ell$  be a proper labelling of  $C_n$  that assigns label 3 to only one edge. Since  $\ell$  is proper, it is obliged to assign label 1 to at most  $\frac{1}{2}|E| - 1$  edges of  $C_n$  and label 2 to the rest. This however would lead to  $\ell$  assigning label 2 on at least  $\frac{1}{2}|E|$  edges, which is a contradiction to Claim 2.7. Thus,  $\ell$  must assign label 3 on at least two edges. Similarly to before, a labelling that assigns label 3 to exactly two edges, label 1 to at most  $\frac{1}{2}|E| - 1$  edges, and label 2 to the rest of the edges, would achieve the optimal value. The following  $\ell$  is one such proper labelling:  $\ell(e_1) = 1, \ell(e_2) = 1, \ell(e_3) = 2, \ell(e_4) = 2, \ell(e_5) = 1, \dots, \ell(e_{n-3}) = 2, \ell(e_{n-2}) = 2, \ell(e_{n-1}) = 3, \ell(e_n) = 3$ .  $\square$

### 3 Complexity aspects

In this section, we establish both a negative and a positive result on the complexity of computing the parameter  $\text{mE}_k(G)$  for some input integer  $k$  and nice graph  $G$ . More precisely:

- We first prove that determining  $\text{mE}_2(G)$  is  $\mathcal{NP}$ -complete, even when  $G$  is restricted to a planar bipartite graph. Recall that this is contrasting with the complexity of determining whether  $\chi_\Sigma(G) \leq 2$  holds for a given bipartite graph  $G$ , which is a problem that can be solved in polynomial time due to a result of Thomassen, Wu and Zhang [20].
- We then prove that determining  $\text{mE}_k(G)$  can be done in polynomial time whenever  $k$  is fixed and  $G$  is a graph with bounded treewidth.

#### 3.1 A negative result for bipartite graphs

In this section, we prove, in Theorem 3.2 below, that the problem of determining  $\text{mE}_k(G)$  is  $\mathcal{NP}$ -complete in planar bipartite graphs  $G$ .

Let us first introduce the  $k$ -*gadget*, for  $k \geq 2$ , which will be useful for proving Theorem 3.2. To build this gadget, let us start with  $k - 1$  *stars*, each having a *center*  $s_i$  with  $d(s_i) = k + 1$  for every  $i \in \{1, \dots, k - 1\}$ . For each star, pick an arbitrary edge  $s_i y_i$  and identify all the  $y_i$ 's into a single vertex  $y$ , which is called the *representative* of the gadget. Finally add another vertex  $u$ , called the *root* of the gadget, and join it to  $y$  via an edge. It is clear that  $d(u) = 1$  and  $d(y) = k$ . Each  $k$ -gadget is a tree with  $\mathcal{O}(k^2)$  edges. Let  $v$  be a vertex of a graph  $G$ , and  $H$  be a  $k$ -gadget. The operation of adding  $H$  to  $G$  and identifying the root  $u$  of  $H$  with  $v$  is called *attaching  $H$  to  $v$* .

**Claim 3.1.** *Let  $G(V, C, E)$  be a bipartite graph and  $\ell$  be any proper 2-labelling of  $G$  such that  $\sigma(\ell) \leq |E| + c$ , for  $c = |C|$ . Let  $H$  be any  $p$ -gadget attached to  $G$ , where  $p - 1 > c$ , forming the graph  $G'$ . Let  $y$  be the representative of  $H$ . Let  $\ell'$  be a labelling of  $G'$  such that for all edges  $e \in E(G)$ , we have  $\ell'(e) = \ell(e)$ . If at least one edge  $e$  of  $H$  incident to  $y$  is labelled 2 by  $\ell'$ , then there are at least two edges of  $H$  that are labelled 2 by  $\ell'$ .*

*Proof of the claim.* Let us suppose that at least one of the edges of  $H$  incident to  $y$  is labelled 2. Let  $z \in V \cup C$  be the vertex of  $G'$  to which  $H$  has been attached.

Let us first assume that the edge  $zy$  is labelled 2. If  $y$  is incident to only a single edge labelled 2 (i.e.,  $zy$ ), then its colour is  $c_\ell(y) = p + 1$ . Since all its  $p - 1$  neighbours (different from  $z$ ) have degree  $p + 1$ , each of them must be incident to at least one edge labelled 2 as otherwise it would have the same colour as  $y$ . This leads to at least  $p > c$  edges labelled 2, which is a contradiction (observe that since  $\sigma(\ell) \leq |E| + c$ , there are at most  $c$  edges labelled 2). Otherwise, if  $y$  has exactly one other incident edge (different from  $yz$ ) labelled 2, say the edge  $yw$ , then we are done.

Then, let us assume that  $\ell(yz) = 1$ . Moreover, let us assume that some edge incident to  $y$ , say  $yw_1$  different from  $yz$ , is labelled 2. Then  $c_\ell(y) \geq p + 1$  with  $c_\ell(y) = p + 1$  if  $yw_1$  is the unique edge incident to  $y$  labelled 2. In this case, each one of the  $p - 2$  neighbours of  $y$  (different from  $z$  and  $w_1$ ) must be incident to at least one edge labelled 2, leading to at least  $p - 1 > c$  edges labelled 2, which is a contradiction. Thus  $c_\ell(y) > p + 1$ , which means there is at least one more edge  $yw_2$  incident to  $y$  labelled 2.  $\diamond$

We are now ready for proving our result.

**Theorem 3.2.** *Let  $G$  be a nice planar bipartite graph,  $k \geq 2$  and  $q \in \mathbb{N}$ . The problem of deciding if  $\text{mE}_k(G) \leq q$  is  $\mathcal{NP}$ -complete.*

*Proof.* The problem is clearly in  $\mathcal{NP}$ . We focus on showing it is also  $\mathcal{NP}$ -hard. The proof is done by reduction from PLANAR MONOTONE 1-IN-3 SAT, which was shown to be  $\mathcal{NP}$ -complete in [17]. In this problem, a 3CNF formula  $F$  is given as input, which has clauses with exactly three distinct variables all of which appear only positively. We say that a bipartite graph  $G' = (V, C, E)$  corresponds to  $F$  if it is constructed from  $F$  in the following way: for each variable  $x_i$  of  $F$  add a *variable vertex*  $v_i$  in  $V$  and for each clause  $C_j$  of  $F$  add a *clause vertex*  $c_j$  in  $C$ . Then the edge  $v_i c_j$  is added if variable  $x_i$  appears in clause  $C_j$ . Furthermore,  $F$  is valid as input to the PLANAR MONOTONE 1-IN-3 SAT problem if the graph  $G'$  that corresponds to  $F$  is planar. The question



is whether there exists a 1-in-3 truth assignment of  $F$ ; that is a truth assignment to the variables of  $F$  such that each clause has exactly one variable with the value *true*.

Observe now that we may assume that each variable appears in at least two clauses. If there exists a variable, say  $x_i$ , that belongs to a single clause  $C = (x_i \vee x_j \vee x_k)$ , let us add another clause  $C'$  identical to  $C$ . Clearly, the obtained formula  $F'$  is 1-in-3 satisfiable if and only if  $F$  is. Moreover, the graph corresponding to  $F'$  is planar. Indeed, consider a planar embedding of the graph  $G' \setminus \{v_i\}$  (where  $v_i$  is the vertex of  $G'$  corresponding to  $x_i$ ). Clearly,  $v_j$  and  $v_k$  are in a same face (since their common neighbour, corresponding to  $C$ , has degree 2 in  $G' \setminus \{v_i\}$ ). The graph obtained by adding a vertex  $v_i$  (adjacent to the vertex corresponding to  $C$ ) and a vertex corresponding to  $C'$  (adjacent to  $v_i, v_j$  and  $v_k$ ) in this face is planar.

Let us prove the statement for  $k = 2$ . Let  $F$  be a 3CNF formula with  $c$  clauses that is given as input to the PLANAR MONOTONE 1-IN-3 SAT problem. Our goal is to construct a planar bipartite graph  $G$  such that  $F$  is 1-in-3 satisfied if and only if  $\text{mE}_2(G) \leq |E(G)| + c$ .

Start from  $G' = (V, C, E)$  being the planar bipartite graph that corresponds to  $F$ , with  $V$  being the set of the variable vertices  $v_i$  and  $C$  being the set of the clause vertices  $c_j$ . Note that in  $F$ , each clause has exactly three variables but there is no bound on how many times a variable appears in  $F$ . Thus for each  $v_i \in V$ , we have  $d(v_i) \geq 2$  and for each  $c_j \in C$ , we have  $d(c_j) = 3$ . It follows that  $|C| = c$  and  $|V| \leq 3c$ .

Proceed by modifying  $G'$  by adding the gadgets described earlier. For each variable vertex  $v_i$ , let  $d_i$  be the initial degree of  $v_i$  in  $G'$ . Let  $d_{v,i} = (d_i - 1)(c + 1) + d_i$  and  $d_c = 3(c + 1) + 3$ . For each variable vertex  $v_i$ , for all  $1 \leq j < d_i$ , attach  $c + 1$  copies of the  $(d_{v,i} + j)$ -gadget. On each clause vertex  $c_j$ , attach  $c + 1$  copies of the  $d_c$ -gadget,  $c + 1$  copies of the  $(d_c + 2)$ -gadget and  $c + 1$  copies of the  $(d_c + 3)$ -gadget. Name the resulting graph  $G$  and observe that the degree of each  $v_i$  in  $G$  becomes equal to  $d_{v,i}$  and the degree of each  $c_j$  in  $G$  becomes equal to  $d_c$ . Clearly, the construction of  $G$  is achieved in polynomial time. Finally observe that since  $G'$  is planar and the attached gadgets are actually trees,  $G$  is also planar.

Let  $\ell$  be a proper 2-labelling of  $G$  such that  $\sigma(\ell) \leq |E(G)| + c$ , i.e., there are at most  $c$  edges of  $G$  labelled 2 by  $\ell$ . Observe that  $G$  contains  $p$ -gadgets for  $p \in \{d_{v,i} + 1, d_{v,i} + 2, \dots, d_{v,i} + d_i - 1, d_c, d_c + 2, d_c + 3\}$  and  $d_{v,i} - 1, d_c - 1 > c$ . Thus Claim 3.1 holds for each gadget attached to  $G$ .

**Claim 3.3.** *For any proper 2-labelling  $\ell$  of  $G$  such that  $\sigma(\ell) \leq |E(G)| + c$ , we have that:*

- $c_\ell(v_i) \notin \{d_{v,i} + 1, d_{v,i} + 2, \dots, d_{v,i} + d_i - 1\}$  for each variable vertex  $v_i \in V$ ;
- $c_\ell(c_j) \notin \{d_c, d_c + 2, d_c + 3\}$  for each clause vertex  $c_j \in C$ .

*Proof of the claim.* Indeed, each variable vertex  $v_i$  is adjacent to  $c + 1$  copies of the  $(d_{v,i} + 1)$ -gadget and at most  $c$  edges are labelled 2 by  $\ell$ . Thus, at least one of the  $(d_{v,i} + 1)$ -gadgets, let us call it  $H$ , that is attached to  $v_i$ , has all of its edges labelled 1. Moreover,  $v_i$  is adjacent to the representative  $y$  of  $H$  which has degree  $d(y) = d_{v,i} + 1$ . Since all the edges of  $H$  are labelled 1, the colour  $c_\ell(y)$  of  $y$  is  $d_{v,i} + 1$  and thus this colour is forbidden for  $v_i$ , i.e.,  $c_\ell(v_i) \neq d_{v,i} + 1$ .

By repeating the same arguments for the  $(d_{v,i} + 2)$ -gadgets attached to  $v_i$ , we deduce that  $c_\ell(v_i) \neq d_{v,i} + 2$ . Similarly, by considering the  $d_c$ -gadgets (resp., the  $(d_c + 2)$ - and  $(d_c + 3)$ -gadgets) attached to any clause vertex  $c_j$ , we get that  $c_\ell(c_j) \notin \{d_c, d_c + 2, d_c + 3\}$ .  $\diamond$

**Claim 3.4.** *Let  $\ell$  be any proper 2-labelling of  $G$  such that  $\sigma(\ell) \leq |E(G)| + c$ . Then all edges of the attached gadgets must be labelled 1.*

*Proof of the claim.* Observe that for each clause vertex  $z \in C$ , at least one of its incident edges must be labelled 2. If this were not the case, then  $c_\ell(z) = d_c$ , and this is not allowed due to Claim 3.3.

Let  $H$  be a gadget attached to  $z$ , and  $y$  be the representative of  $H$ . Suppose  $\ell(yz) = 2$ . It follows from Claim 3.1 that there are at least two edges of  $H$  labelled 2. Recall that the number of edges of  $G$  that can be labelled 2 is at most  $c$ . Thus, the number of edges of  $G$ , that do not belong to  $H$  and can be labelled 2, is at most  $c - 2$ . Furthermore, there are  $c - 1$  clause vertices in  $G$  that are different from  $z$ . It follows that there exists a clause vertex that has all of its incident edges labelled 1, a contradiction. Thus, each  $z \in C$  must be incident to an edge  $wz$  with  $\ell(wz) = 2$

and  $w$  cannot belong to a gadget attached to  $z$ . It follows that there must be  $|C| = c$  edges of  $G'$  labelled 2 and since  $\sigma(\ell) \leq |E(G)| + c$ , all the edges of the attached gadgets are labelled 1.  $\diamond$

It follows from Claim 3.4, that the only possible colours induced on the vertices of  $G'$  by a proper 2-labelling  $\ell$  of  $G$  are:

- $c_\ell(v_i) \in \{d_{v,i}, d_{v,i} + 1, d_{v,i} + 2, \dots, d_{v,i} + d_i - 1, d_{v,i} + d_i\}$  for each variable vertex  $v_i \in V$ ,
- $c_\ell(c_j) \in \{d_c, d_c + 1, d_c + 2, d_c + 3\}$  for each clause vertex  $c_j \in C$ .

The following hold due to Claim 3.3:

- For every variable vertex  $v_i$ , we have  $c_\ell(v_i) \in \{d_{v,i}, d_{v,i} + d_i\}$ . Observe that  $c_\ell(v_i) = d_{v,i}$  if all edges of  $G'$  adjacent to  $v_i$  are labelled 1, and  $c_\ell(v_i) = d_{v,i} + d_i$  if all edges of  $G'$  adjacent to  $v_i$  are labelled 2.
- For every clause vertex  $c_j$ , we have  $c_\ell(c_j) = d_c + 1$ , which corresponds to two edges of  $G'$  adjacent to  $c_j$  labelled 1 and only one edge labelled 2.

We are now ready to show the equivalence between finding a 1-in-3 truth assignment  $\phi$  of  $F$  and finding a proper 2-labelling  $\ell$  of  $G$  such that  $\sigma(\ell) = \text{mE}_2(G) \leq |E(G)| + c$ . An edge  $v_i c_j$  of  $G'$  labelled 2 (respectively 1) by  $\ell$  corresponds to variable  $x_i$  bringing truth value *true* (respectively *false*) to clause  $C_j$  by  $\phi$ . Also, we know that in  $G'$ , every variable vertex  $v_i$  is incident to  $n \geq 1$  edges, all having the same label (either 1 or 2). Accordingly, the corresponding variable  $x_i$  brings, by  $\phi$ , the same truth value to the  $n$  clauses of  $F$  that contain it. Finally, in  $G'$ , every clause vertex  $c_j$  is incident to two edges labelled 1 and one edge labelled 2. This corresponds to the clause  $C_j$  being regarded as satisfied by  $\phi$  only when it has exactly one true variable.  $\square$

### 3.2 A positive result for graphs with bounded treewidth

Given a graph  $G = (V, E)$ , a *tree-decomposition* of  $G$  is a pair  $(T, \mathcal{X})$  such that  $T = (V(T), E(T))$  is a tree and  $\mathcal{X} = \{X_t \subseteq V \mid t \in V(T)\}$  is a family of subsets (called *bags*) of vertices of  $G$  such that:

- $V = \bigcup_{t \in V(T)} X_t$ ;
- for every  $uv \in E$ , there exists  $t \in V(T)$  with  $u, v \in X_t$ ; and
- for every  $v \in V$ , the subset  $\{t \in V(T) \mid v \in X_t\}$  induces a subtree of  $T$ .

The *width* of  $(T, \mathcal{X})$  is equal to  $\max_{t \in V(T)} |X_t| - 1$  and the *tree-width*  $\text{tw}(G)$  is the minimum width of a tree-decomposition of  $G$ .

A tree-decomposition  $(T, \mathcal{X})$  is *nice* [7] if  $T$  is rooted in  $r \in V(T)$  and every node  $t \in V(T)$  is exactly of one of the following four types:

1. **Leaf:**  $t$  is a leaf of  $T$  and  $|X_t| = 1$ .
2. **Introduce:**  $t$  has a unique child  $t'$  and there exists  $v \in V$  such that  $X_t = X_{t'} \cup \{v\}$ .
3. **Forget:**  $t$  has a unique child  $t'$  and there exists  $v \in V$  such that  $X_{t'} = X_t \cup \{v\}$ .
4. **Join:**  $t$  has exactly two children  $t', t''$  and  $X_t = X_{t'} = X_{t''}$ .

It is well known that every graph  $G = (V, E)$  admits a nice tree-decomposition  $(T, \mathcal{X})$  rooted in  $r \in V(T)$ , that has width equal to  $\text{tw}(G)$ ,  $|V(T)| = \mathcal{O}(|V|)$  and  $X_r = \{\emptyset\}$  [7].

Let  $(T, \mathcal{X})$  be a rooted tree-decomposition (with root  $r$ ) of  $G$  and  $t \in V(T)$ . A subtree of  $T$  induced by  $t$  and its descendants is denoted as  $T_t$  and the corresponding subgraph of  $G$ , i.e., the graph induced by  $\bigcup_{t' \in V(T_t)} X_{t'}$ , is denoted by  $G_t$  (clearly,  $G_r = G$ ). For every  $v \in V(G_t)$ , let  $N_t(v)$  denote the neighbourhood of  $v$  in  $G_t$ , that is  $N_t(v) = \{u \in V(G_t) : uv \in E(G_t)\}$ . A *quasi  $k$ -labelling* of  $G_t$  consists of a pair of functions  $(\ell, c)$ , with  $\ell : E(G_t) \rightarrow \{1, \dots, k\}$  and  $c : V(G_t) \rightarrow \mathbb{N}$ ,

such that  $c$  is a proper vertex-colouring of  $G_t$ , for every  $v \in V(G_t) \setminus X_t$  we have  $c(v) = c_\ell(v)$ , and for every  $v \in V(X_t)$  we have  $c(v) \geq c_\ell(v)$ . Intuitively, the notion of quasi  $k$ -labelling is a generalisation of proper  $k$ -labellings that allows us to further modify the labels (and thus the induced colours) of the edges of  $X_t$  if this is needed in order to extend a proper  $k$ -labelling of  $G_t$  into a proper  $k$ -labelling of  $G_{t'}$ , where  $t'$  is the parent of  $t$  in  $T$ . Finally, let  $s_t(\ell) = \sum_{e \in E(G_t)} \ell(e)$ .

Observe that every proper  $k$ -labelling  $\ell'$  of  $G$  induces a quasi  $k$ -labelling of  $G_t$ . For every  $e \in E(G_t)$  and  $v \in V(G_t)$ , let  $\ell(e) = \ell'(e)$  and  $c(v) = c_{\ell'}(v)$ . The pair  $(\ell, c)$  is a quasi  $k$ -labelling of  $G_t$ . Indeed, since  $(T, \mathcal{X})$  is a tree-decomposition of  $G$ , for every internal node  $t$  of  $T$ ,  $X_t$  is a separator between  $G_t - X_t$  and  $G - V(G_t)$ . Put differently, there are no edges between vertices of  $G_t - X_t$  and  $G - V(G_t)$ . Furthermore, if  $r$  is such that  $X_r = \emptyset$ , then a quasi  $k$ -labelling of  $G_r$  is a proper  $k$ -labelling of  $G$ . Indeed, it is true (by definition) that a quasi  $k$ -labelling of  $G_r$  differs from a proper  $k$ -labelling only on the vertices of  $X_r$  and since  $X_r = \emptyset$  and  $G_r = G$  the observation follows.

**Theorem 3.5.** *Let  $k \geq 2$  and  $\text{tw} \geq 1$  be two fixed integers. Given a nice graph  $G = (V, E)$  with  $|V| = n$  and an integer  $s$ , the problem of deciding whether  $\text{mE}_k(G) \leq s$  holds can be solved in polynomial time if  $G$  belongs to the family of graphs that have width at most  $\text{tw}$  (and in linear time if  $G$  is additionally of bounded maximum degree).*

*Proof.* Let us start by giving some definitions. Let  $\Delta = \Delta(G)$  denote the maximum degree of  $G$ . For every  $t \in V(T)$ , let  $|X_t| = w_t$ ,  $|E(G[X_t])| = q_t$ ,  $X_t = \{v_1, \dots, v_{w_t}\}$  and  $E(G[X_t]) = \{e_1, \dots, e_{q_t}\}$  (to simplify the notation, we will simply denote  $q_t$  and  $w_t$  by  $q$  and  $w$  respectively). Let  $\mathcal{F}_t = \{1, \dots, k\}^q \times \{1, \dots, k\Delta\}^w \times \{0, \dots, k\Delta\}^w$  and  $(L, FC, CB) \in \mathcal{F}_t$ , where  $L = \{l_1, \dots, l_q\}$ ,  $FC = \{f_1, \dots, f_w\}$  and  $CB = \{b_1, \dots, b_w\}$ . The labels we “intent” to assign to the edges of  $X_t$  are in  $L$ , the “final colours” induced by these labels on the vertices of  $X_t$  are in  $FC$ , and in  $CB$  we can find the contribution to these colours that come “from below” (meaning the part of these final colours that are due to edges between  $X_t$  and  $G_t - X_t$ ). Furthermore, for  $X'_t \subseteq X_t$  with  $X'_t = \{u_1, \dots, u_{w'}\}$  (where  $w' \leq w$ ), let  $FC|_{X'_t} = \{f'_1, \dots, f'_{w'}\}$  be defined by setting, for each  $j \in \{1, \dots, w'\}$ ,  $f'_j = f_{i_j}$  where  $u_j = v_{i_j}$  ( $L|_{X'_t}$  and  $CB|_{X'_t}$  are defined similarly).

Moreover, a quasi labelling  $(\ell, c)$  of  $G_t$  is said *compatible* with  $(L, FC, CB) \in \mathcal{F}_t$  if, for each  $i \in \{1, \dots, q\}$  and  $j \in \{1, \dots, w\}$ , we have that  $\ell(e_i) = l_i$ ,  $c(v_j) = f_j$ , and  $b_j = \sum_{x \in N_t(v_j) \setminus X_t} \ell(v_j x)$ . This implies that, for all  $i \in \{1, \dots, q\}$  and  $j \in \{1, \dots, w\}$ ,

$$\sum_{z \in N_t(v_j)} \ell(zv_j) = b_j + \sum_{z \in N(v_j) \cap X_t, e_i = v_j z} l_i \leq c(v_j) = f_j.$$

Among all quasi labellings compatible with  $(L, FC, CB)$ , let us denote as  $(\ell^*, c^*)$  one such compatible labelling that minimises the sum of the labels assigned by  $\ell^*$ . That is, for any  $t \in V(T)$ , we have  $s_t(\ell^*) \leq s_t(\ell)$  for every quasi labelling  $\ell$  compatible with  $(L, FC, CB)$ . Let  $\alpha_t(L, FC, CB) = s_t(\ell^*)$ . In essence, for each possible  $(L, FC, CB) \in \mathcal{F}_t$ , we have that  $\alpha_t(L, FC, CB)$  is equal to the sum of the labels of an optimal (in terms of sum of labels) quasi labelling  $(\ell^*, c^*)$  of  $G_t$  that is compatible with  $(L, FC, CB)$ . Note that not all  $(L, FC, CB) \in \mathcal{F}_t$  admit compatible quasi labellings. If  $(L, FC, CB) \in \mathcal{F}_t$  has no compatible quasi labelling, then we set  $\alpha_t(L, FC, CB) = \infty$ .

Finally, let us set

$$\text{Table}(t) = ((L, FC, CB, \alpha_t(L, FC, CB))_{(L, FC, CB) \in \mathcal{F}_t}$$

being the table associated to each  $t \in V(T)$ . Note that

$$|\text{Table}(t)| = \mathcal{O}(k^q (k\Delta + 1)^{2w}) = \mathcal{O}(k^{(\text{tw}(G)+1)^2} (k\Delta + 1)^{2\text{tw}(G)+2}),$$

since  $q \leq \binom{\text{tw}(G)+1}{2} = \mathcal{O}((\text{tw}(G)+1)^2)$  and  $w \leq \text{tw}(G)+1$ . Furthermore, since  $r$  is such that  $X_r = \emptyset$ , then  $\alpha_r = \alpha_r(\emptyset, \emptyset, \emptyset)$  is equal to the sum of an optimal proper  $k$ -labelling of  $G_r$  and thus  $\text{Table}(r) = ((\emptyset, \emptyset, \emptyset, \alpha_r))$ , where  $\alpha_r = \text{mE}_k(G)$ . All that remains to be done is to compute this  $\text{Table}(t)$  for every  $t \in V(T)$ . We present a dynamic-programming algorithm that performs this computation bottoms up; that is, starting from the leaves of  $T$  and progressing towards  $r$ . The computation depends on the type of  $t$ .

Let  $t$  be a leaf node. Recall that  $|X_t| = 1$  and thus there are no edges in  $X_t$ . For every  $y \in \{1, \dots, k\Delta\}$  and  $(L, FC, CB) \in \mathcal{F}_t$ , the  $\alpha_t(L, FC, CB)$  entry of  $\text{Table}(t)$  is defined as:

$$\alpha_t(L, FC, CB) = \begin{cases} 0, & \text{if } (L, FC, CB) = (\emptyset, \{y\}, \{0\}); \\ \infty, & \text{otherwise.} \end{cases}$$

Let  $t$  be an introduce node and  $t'$  be its unique child. Set  $w = |X_{t'}|$ , and let  $v$  be such that  $X_t = X_{t'} \cup \{v\} = \{v_1, \dots, v_w, v_{w+1} = v\}$ . Moreover, let  $E(X_t) = \{e_1, \dots, e_q, e_{q+1}, \dots, e_{q+h}\}$ , where  $E(X_{t'}) = \{e_1, \dots, e_q\}$ . Essentially, the set  $\{e_{q+1}, \dots, e_{q+h}\}$  contains the edges between  $v$  and the other vertices of  $X_t$ . By induction, we can assume that  $\text{Table}(t')$  is already computed. Let us show how to compute  $\text{Table}(t)$ . Let

$$(L = (l_1, \dots, l_{q+h}), FC = (f_1, \dots, f_{w+1}), CB = (b_1, \dots, b_{w+1})) \in \mathcal{F}_t.$$

There is a quasi labelling of  $G_t$  compatible with  $(L, FC, CB)$  only if the following three (easily computable) conditions are satisfied:

- The final colour  $f_{w+1}$  that corresponds to  $v$  is not in conflict with the final colours that correspond to the neighbours of  $v$  in  $X_t$ . That is, for each  $j \in \{1, \dots, w\}$  such that  $v_j \in N_t(v) \cap X_t$ , we have  $f_{w+1} \neq f_j$ .
- Since  $v$  is introduced in  $X_t$ , we have  $N_t(v) \setminus X_t = \emptyset$  and, as a consequence,  $c(v)$  cannot have any contribution coming from  $G_t \setminus X_t$ . That is  $b_{w+1} = 0$ .
- The colour of each vertex in  $G_t$  cannot exceed the final colour that corresponds to it. That is, for every  $v_i \in X_t$ , we must have

$$b_i + \sum_{j=1}^{q+h} l_j \mathbb{I}_{i,j} \leq f_i,$$

$$\text{where } \mathbb{I}_{i,j} = \begin{cases} 1, & \text{if there is } w \in N(v_i) \cap X_t \text{ such that } vw = e_j; \\ 0, & \text{otherwise.} \end{cases}$$

If one of these three conditions is not satisfied, then  $\alpha_t(L, FC, CB) = \infty$ . Otherwise, let us set

$$\alpha_t(L, FC, CB) = \alpha_{t'}(L|_{X_{t'}}, FC|_{X_{t'}}, CB|_{X_{t'}}) + \sum_{j=q+1}^{q+h} l_j.$$

Following the above process, the element  $((L, FC, CB), \alpha_t(L, FC, CB))$  is added to  $\text{Table}(t)$  for every  $(L, FC, CB) \in \mathcal{F}_t$ .

Let  $t$  be a forget node and  $t'$  be its unique child. Set  $w = |X_t|$ , and let  $v$  be such that  $X_{t'} = X_t \cup \{v\} = \{v_1, \dots, v_w, v_{w+1} = v\}$ . Moreover, let  $E(X_{t'}) = \{e_1, \dots, e_q, e_{q+1}, \dots, e_{q+h}\}$ , where  $E(X_t) = \{e_1, \dots, e_q\}$ . By induction, we can assume that  $\text{Table}(t')$  is already computed. Let us show how to compute  $\text{Table}(t)$ .

Let  $(L, FC, CB) \in \mathcal{F}_t$ . Let  $\Gamma_{t'}$  be the subset of  $\mathcal{F}_{t'}$  that consists of all  $(L', FC', CB') \in \mathcal{F}_{t'}$  such that  $(L, FC, CB) = (L'|_{X_t}, FC'|_{X_t}, CB'|_{X_t})$  (i.e.,  $(L, FC, CB)$  must be the restriction to  $X_t$  of some  $(L', FC', CB') \in \mathcal{F}_{t'}$ ) and such that  $f'_{w+1} = b'_{w+1} + \sum_{q+1 \leq j \leq q+h} l'_j$ . The latter condition allows to respect the property of quasi labellings. Since  $v \in G_t - X_t$ , the "colour" that it received so far (with a contribution of  $b'_{w+1}$  from the vertices in  $G_{t'} - X_{t'}$ ) plus the labels  $l'_{q+1}, \dots, l'_{q+h}$  of its incident edges in  $X_{t'}$  must equal its "final" colour  $f'_{w+1}$ . Finally, let

$$\alpha_t(L, FC, CB) = \min_{\gamma \in \Gamma_{t'}} \alpha_{t'}(\gamma).$$

Following the above process, the element  $((L, FC, CB), \alpha_t(L, FC, CB))$  is added to  $\text{Table}(t)$  for every  $(L, FC, CB) \in \mathcal{F}_t$ .

Let  $t$  be a join node,  $t'$  and  $t''$  be its two children, with  $X_t = X_{t'} = X_{t''} = \{v_1, \dots, v_w\}$  and  $E(X_t) = E(X_{t'}) = E(X_{t''}) = \{e_1, \dots, e_q\}$ . By induction, we can assume that  $\text{Table}(t')$  and  $\text{Table}(t'')$  have already been computed. Let us show how to compute  $\text{Table}(t)$ .

Let  $(L, FC, CB) \in \mathcal{F}_t$ . Let  $\Gamma_t$  be the set of pairs  $((L, FC, CB'), (L, FC, CB''))$  such that  $(L, FC, CB') \in \mathcal{F}_{t'}$  and  $(L, FC, CB'') \in \mathcal{F}_{t''}$  such that  $CB = CB' + CB''$  (meaning that for each  $j \in \{1, \dots, w\}$  we have  $b_j = b'_j + b''_j$ , where  $b_j \in CB$ ,  $b'_j \in CB'$  and  $b''_j \in CB''$ ). Then, let

$$\alpha_t(L, FC, CB) = \min_{((L, FC, CB'), (L, FC, CB'')) \in \Gamma_t} \alpha_{t'}(L, FC, CB') + \alpha_{t''}(L, FC, CB'') - \sum_{i=1}^q l_i.$$

Following the above process, the element  $((L, FC, CB), \alpha_t(L, FC, CB))$  is added to  $\text{Table}(t)$  for every  $(L, FC, CB) \in \mathcal{F}_t$ .

In all cases, it can be shown by induction that  $\alpha_t(L, FC, CB) \neq \infty$  if and only if there is a quasi labelling of  $G_t$  compatible with  $(L, FC, CB)$ , and, moreover, that if  $\alpha_t(L, FC, CB) \neq \infty$ , then it is the minimum sum of the edge labels among all quasi labellings of  $G_t$  compatible with  $(L, FC, CB)$ .  $\square$

## 4 Particular behaviours of the problem

In this section, we study some behaviours of the problem of determining  $\text{mE}_k(G)$  for some integer  $k$  and nice graph  $G$ . We start by establishing that there is no systematic relationship between the proper labellings we are interested in and those considered in [1] and [5]. We then prove that, in general, using large labels might be needed for designing proper labellings  $\ell$  verifying  $\sigma(\ell) = \text{mE}(G)$ . This actually remains true in cases where  $G$  is a tree.

### 4.1 Minimising the maximum colour versus minimising the sum of labels

As described in the introductory section, quite recently the authors of [5] investigated proper labellings that minimise the maximum resulting vertex colour. The formal definitions are as follows. For a given graph  $G$  and a labelling  $\ell$  of  $G$ , let  $\text{mS}(G, \ell)$  denote the maximum vertex colour  $c_\ell(v)$  induced by  $\ell$  over all vertices  $v$  of  $G$ . For a given  $k \geq \chi_\Sigma(G)$ , let  $\text{mS}_k(G)$  denote the smallest value of  $\text{mS}(G, \ell)$  over all proper  $k$ -labellings of  $G$ . Now, the main parameter of interest is  $\text{mS}(G)$ , which is defined as the minimum value of  $\text{mS}_k(G)$  over all values of  $k \geq \chi_\Sigma(G)$ .

As established in Observation 2.2 determining  $\text{mE}(G)$  for a nice graph  $G$  can equivalently be seen as finding a proper labelling of  $G$  that minimises the sum of resulting vertex colours. Thus, one could think that maybe  $\text{mE}(G)$  is a good approximation of  $\text{mS}(G)$ , or *vice-versa*. In this section, we show that this is actually not the case.

The next result shows that, when constructing a proper labelling  $\ell$  of a graph  $G$  with  $\text{mS}(G, \ell) = \text{mS}(G)$ , we might have  $\sigma(\ell)$  being arbitrarily far from  $\text{mE}(G)$ . In other words, minimising the maximum colour does not imply minimising the sum of labels. This actually remains true for trees.

**Theorem 4.1.** *There exist nice trees  $T$  with arbitrarily large maximum degree  $\Delta \geq 2$  for which, for any proper labelling  $\ell$  achieving  $\text{mS}(T, \ell) = \text{mS}(T)$ , we have  $\text{mE}(T, \ell) = \text{mE}(T) + \Delta - 2$ .*

*Proof.* Consider the following tree  $T$  with maximum degree  $\Delta \geq 2$ . We start from a vertex  $v$  with  $\Delta$  neighbours  $u_1, \dots, u_\Delta$ , each of which is adjacent to  $\Delta - 1$  leaves. In other words, all neighbours of  $v$  have degree  $\Delta$ , and all other vertices are leaves at distance exactly 2 from  $v$ .

Now consider a proper labelling  $\ell$  of  $T$  that minimises the maximum colour, i.e.,  $\text{mS}(T, \ell) = \text{mS}(T)$ . Since  $T$  has adjacent vertices with degree  $\Delta$ , we have  $\text{mS}(T, \ell) \geq \Delta + 1$ . One possible way to attain  $\text{mS}(T, \ell) = \Delta + 1$  is to have all edges incident to  $v$  being labelled 1, and, for each  $u_i$ , to have exactly one incident edge going to a leaf being labelled 2 and all other  $\Delta - 2$  incident edges being labelled 1. Indeed, we get  $c_\ell(v) = \Delta \neq \Delta + 1 = c_\ell(u_i)$  for every  $i \in \{1, \dots, \Delta\}$ . Actually, this is the only way to have  $\text{mS}(T, \ell) = \Delta + 1$ , because if we label the edges incident to  $v$  so that  $c_\ell(v) = \Delta + 1$ , then it is easy to see that the vertex  $u_i$  such that  $\ell(vu_i) = 2$  would get

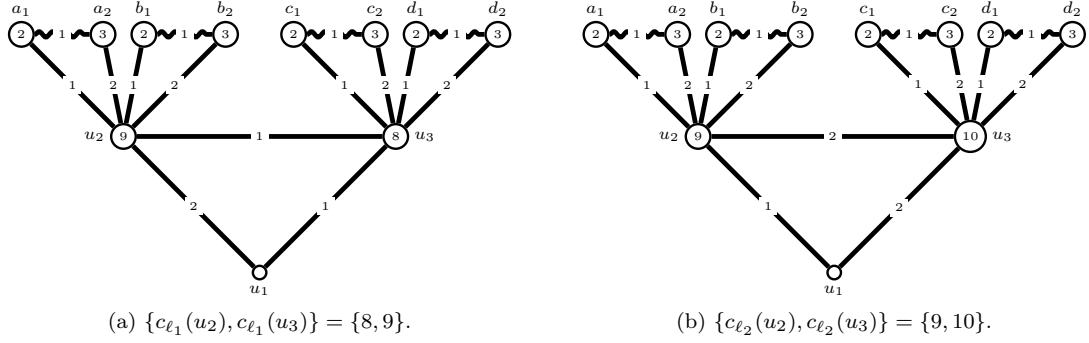

Figure 1: The only proper 2-labellings  $\ell_1$  (left) and  $\ell_2$  (right) of the  $T_2$  gadget, used in the construction illustrated in Figure 2. The induced colours for each labelling are represented as integers in the corresponding vertices. Vertex  $u_1$  is called the *root* of the gadget. Wiggly edges are edges that could be labelled either 1 or 2.

$c_\ell(u_i) \geq \Delta + 2$  to avoid a colour conflict between  $v$  and  $u_i$ . Therefore, there is only one general way to label (actually 2-label)  $T$  so that  $\text{mS}(T, \ell) = \text{mS}(T) = \Delta + 1$ , and we note that the number of edges labelled 2 by  $\ell$  is exactly  $\Delta$  (one for each  $u_i$ ). Thus  $\text{mE}(T, \ell) = |E| + \Delta$ .

Observe now that regardless of the value of  $\Delta$ , the 2-labelling  $\ell^*$  of  $T$  where  $\ell^*(vu_1) = \ell^*(vu_2) = 2$  and all other edges are labelled 1 is proper. This is because we get  $c_{\ell^*}(v) = \Delta + 2$ ,  $c_{\ell^*}(u_1) = c_{\ell^*}(u_2) = \Delta + 1$  and  $c_{\ell^*}(u_i) = \Delta$ , for  $i \in \{3, \dots, \Delta\}$ . Thus,  $\text{mE}(T) \leq \text{mE}_2(T) \leq \text{mE}(T, \ell^*) = |E| + 2$  and the difference between  $\sigma(\ell)$  and  $\sigma(\ell^*)$  then gets arbitrarily large as  $\Delta$  grows larger.  $\square$

The next result shows that the converse is also true: a proper labelling that minimises the sum of labels does not necessarily minimise the maximum colour as well.

**Theorem 4.2.** *There exist nice graphs  $G$  with arbitrarily large maximum degree  $\Delta \geq 12$  for which, for any proper 2-labelling  $\ell$  achieving  $\sigma(\ell) = \text{mE}_2(G)$ , we have  $\text{mS}(G, \ell) = \text{mS}(G) + \Delta$ .*

*Proof.* In [5] is exhibited a *spreading gadget*  $G^\wedge$  (a slight modification of the graph depicted in Figure 2) with one *input* (the edge  $u_1u_2$ ) and two *outputs* (the edges  $u_9u_{10}$  and  $u_{12}u_{13}$ ), that are pending edges that must all be assigned the same label (which can be either 1 or 2) by any proper 2-labelling (see Section 4.4 in [5] for details). Having a closer look at  $G^\wedge$ , we note that, regarding our minimisation problem, it has the following property:

**Claim 4.3.** *Let  $\ell$  be a proper 2-labelling of  $G^\wedge$  achieving  $\sigma(\ell) = \text{mE}_2(G^\wedge)$ . Then  $\ell$  assigns label 2 to the input and two outputs of  $G^\wedge$ .*

*Proof of the claim.* As mentioned above, the proper 2-labellings of  $G^\wedge$  are of two kinds: those  $\ell_1$  assigning label 1 to the input and two outputs, and those  $\ell_2$  assigning label 2 to the input and two outputs. Such labellings  $\ell_1$  and  $\ell_2$  are as described in Figure 2 (a) and (b), respectively (see [5]). In particular, it is important to mention that the solid edges in the figures must be labelled as illustrated (up to symmetry), while the only sources of freedom we have are the labels assigned to the wiggly edges, which can each freely be chosen to be 1 or 2.

Let us now determine the minimum sum of labels assigned by these proper labellings:

- For a proper 2-labelling  $\ell_1$  of  $G^\wedge$  assigning label 1 to the input and two outputs, we note, as illustrated in Figure 2 (a), that  $u_5$  and  $u_6$  must get colour 10, which is possible only if the two copies of  $T_2$  attached to  $u_5$  and  $u_6$  are labelled as in Figure 1 (a). Indeed, assuming that one of these copies of  $T_2$ , say the one attached to  $u_5$ , is labelled as in Figure 1 (b), would mean that  $c_{\ell_1}(u_5) = c_{\ell_1}(u_3) = 10$ , and thus  $\ell_1$  would not be a proper labelling. The vertex  $u_7$  must get colour 11, which is not prevented by any of the two ways of labelling the copy of  $T_2$  attached to it. Thus, for  $\ell_1$  to minimise the sum of labels, the copies of  $T_2$  attached to  $u_5$  and  $u_6$  must be labelled as in Figure 1 (a), and the copy of  $T_2$  attached to  $u_7$  must be labelled as in Figure 1 (a) as well (as the sum of labels in the labelling of Figure 1 (b) is

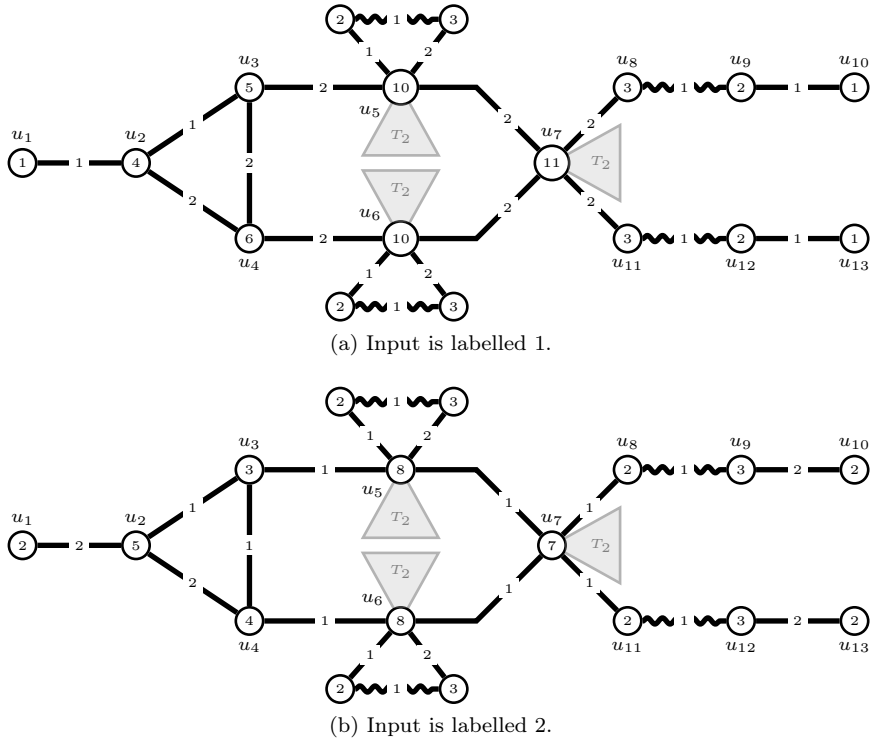

Figure 2: The only proper 2-labellings of the spreading gadget  $G^\lambda$ . A triangle marked as “ $T_2$ ” indicates that a copy of the  $T_2$  gadget (depicted in Figure 1) is attached via its root vertex. That is,  $u_5$  (resp.,  $u_6$  and  $u_7$ ) is identified to the root of one copy of  $T_2$ . The induced colours for each labelling are represented as integers in the corresponding vertices. Wiggly edges are edges that could be labelled either 1 or 2.

larger). All wiggly edges should be assigned label 1. In total, a minimum  $\ell_1$  assigns label 1 to 40 edges and label 2 to 25 edges, and thus  $\sigma(\ell_1) = 90$ .

- By similar arguments, we deduce that, by a proper 2-labelling  $\ell_2$  of  $G^\lambda$  assigning label 2 to the input and two outputs, the copies of  $T_2$  attached to  $u_5$  and  $u_6$  should be labelled as depicted in Figure 1 (b), while the copy of  $T_2$  attached to  $u_7$  should be labelled as depicted in Figure 1 (a) (in particular, the two labellings of  $T_2$  depicted in Figure 1 comply with  $u_7$  having colour 7). Again, the wiggly edges should be labelled 1. In total, a minimum  $\ell_2$  assigns label 1 to 42 edges and label 2 to 23 edges, and thus  $\sigma(\ell_2) = 88$ .

Thus, a proper 2-labelling  $\ell$  of  $G^\lambda$  achieving  $\sigma(\ell) = \text{mE}_2(G^\lambda)$  must assign label 2 to the input and two outputs.  $\diamond$

Now consider the graph operation consisting in taking two copies  $G_1$  and  $G_2$  of  $G^\lambda$ , and identifying the input of  $G_1$  and one output of  $G_2$  (so that the two degree-1 vertices do not get identified together). Thus, if  $u_i^1$  and  $u_i^2$  (for  $1 \leq i \leq 13$ ) denote the vertices of  $G_1$  and  $G_2$  respectively, in  $G^\lambda$  we can either have  $u_9^1 u_{10}^1 = u_1^2 u_2^2$  or  $u_{12}^1 u_{13}^1 = u_1^2 u_2^2$ . As described in [5], this results in a graph  $G$  with one input and three outputs such that, for every proper 2-labelling, the input and three outputs must all be assigned the same label (which can be either 1 or 2). By repeating this operation with more and more copies of  $G^\lambda$ , we can come up with a graph  $G_{1/2}$  with one input and arbitrarily many outputs that must all be assigned the same label (either 1 or 2) by a proper 2-labelling. So there are, essentially, two groups of proper 2-labellings of  $G_{1/2}$ : those  $\ell_1$  assigning label 1 to the input and all outputs, and those  $\ell_2$  assigning label 2 to the input and all outputs. Clearly, a proper 2-labelling  $\ell$  of  $G_{1/2}$  verifying  $\sigma(\ell) = \text{mE}_2(G_{1/2})$ , when restricted to any constituting copy of  $G^\lambda$  in  $G_{1/2}$ , should also be minimum in terms of sum of assigned labels. From Claim 4.3, we thus deduce that a proper 2-labelling  $\ell$  of  $G_{1/2}$  achieving  $\sigma(\ell) = \text{mE}_2(G_{1/2})$  must assign label 2 to the input and all outputs, i.e., must belong to the  $\ell_2$  group mentioned above.

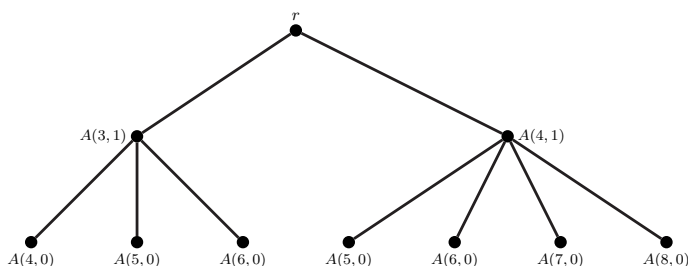

Figure 3: The auxiliary graph  $A(2, 2)$

In particular, the difference between the sum of labels of a minimum  $\ell_1$  and the sum of labels of a minimum  $\ell_2$  gets larger as the number of copies involved in the construction of  $G_{1/2}$  gets larger.

Now let  $G$  be the graph obtained as follows. Consider the graph  $G_{1/2}$  with  $\Delta$  outputs (for any  $\Delta \geq 12$ ), and identify the degree-1 vertices of these  $\Delta$  outputs to a single vertex  $o^*$  (with maximum degree  $\Delta$ , as it can be checked from Figures 1 and 2 that all other vertices of  $G_{1/2}$  have degree at most 6). Note that a proper 2-labelling of  $G$  is also proper for  $G_{1/2}$ , since vertices of degree 1 cannot be involved in conflicts. Also, a proper 2-labelling of  $G_{1/2}$  must be proper in  $G$  as well, since  $o^*$  has degree at least 12 while all its neighbours have degree 2. By these arguments, a proper 2-labelling  $\ell$  of  $G$  verifying  $\sigma(\ell) = \text{mE}_2(G)$  must thus be one of these proper 2-labellings  $\ell_2$  assigning label 2 to the input and all outputs. Such an  $\ell_2$  verifies  $c_{\ell_2}(o^*) = 2\Delta$ . On the other hand, a proper 2-labelling  $\ell_1$  assigning label 1 to all outputs verifies  $c_{\ell_1}(o^*) = \Delta$ . Thus, a proper 2-labelling  $\ell$  of  $G$  verifying  $\sigma(\ell) = \text{mE}_2(G)$  will make  $o^*$  get colour  $2\Delta$ , while there are proper 2-labellings by which  $o^*$  gets colour  $\Delta$ . Note in particular that by our choice of  $\Delta$ , vertex  $o^*$  must indeed be the vertex with the largest colour, as its degree is at least 12, all other vertices have degree at most 6, and we are only assigning labels 1 and 2.  $\square$

## 4.2 Using larger labels can be arbitrarily better

In this section, we present, for any  $k \geq 3$ , a construction for a tree  $T_k$  such that  $\text{mE}_2(T_k) = \text{mE}_3(T_k) = \text{mE}_4(T_k) = \dots = \text{mE}_k(T_k)$  and  $\text{mE}_{k+1}(T_k) < \text{mE}_k(T_k)$ . In other words, for these trees  $T_k$  we need to consider larger labels to design a proper labelling  $\ell$  achieving  $\text{mE}(T_k, \ell) = \text{mE}(T_k)$ .

Let us first introduce the *auxiliary graph*  $A(\alpha, \beta)$  (for  $\alpha \geq 2$  and  $\beta \geq 0$ ), which will serve as the building block for  $T_k$ . This auxiliary graph is a tree and is built recursively as follows: for any  $\alpha^* \in \mathbb{N}$ , define  $A(\alpha^*, 0)$  as a leaf. For any  $\beta > 0$ ,  $A(\alpha, \beta)$  is a tree of height  $\beta$ , rooted in a vertex  $r$  that has  $\alpha$  children. For each  $1 \leq i \leq \alpha$ , let  $c_i$  be the corresponding child of  $r$ ; each  $c_i$  is the root of a  $A(\alpha + i, \beta - 1)$  tree and thus  $d(c_i) = \alpha + i + 1$  (since each  $c_i$  has  $\alpha + i$  children of its own as well as an edge connecting him with his parent). Note that  $d(c_i) \in D(\alpha) = \{\alpha + 2, \dots, 2\alpha + 1\}$  and that, for  $i \neq j$ , we have  $d(c_i) \neq d(c_j)$  (and thus all the values of  $D(\alpha)$  are used exactly once). Finally, we say that  $A(\alpha, \beta)$  is *represented* by  $r$ . The auxiliary graph  $A(2, 2)$  is illustrated in Figure 3.

Let us also define the *pending auxiliary graph* that corresponds to  $A(\alpha, \beta)$  as  $P(\alpha, \beta) = (V, E)$ , where  $V = V(A(\alpha, \beta)) \cup \{v\}$  and  $E = E(A(\alpha, \beta)) \cup vr$ ; in essence  $P(\alpha, \beta)$  is  $A(\alpha, \beta)$  with an extra vertex  $v$  connected to  $r$ . We say that  $P(\alpha, \beta)$  is *pending from*  $v$ . Observe that  $P(\alpha, \beta)$  is locally irregular and thus the labelling  $\ell$  that assigns label 1 to every one of its edges is proper and verifies  $\text{mE}(P(\alpha, \beta), \ell) = |E|$ .

**Lemma 4.4.** *Let  $\beta \in \mathbb{N}^*$  and  $\alpha \geq 2$ . Let  $\ell$  be a proper  $\alpha$ -labelling of the pending auxiliary graph  $P(\alpha, 2\beta)$  pending from  $v$ . Let  $u, w \in V(P(\alpha, 2\beta))$  such that  $1 \leq \text{dist}(u, v) \leq 2$  and  $w$  is the parent of  $u$ . If  $\ell(uw) > 1$ , then  $\text{mE}(P(\alpha, 2\beta), \ell) \geq |E| + \beta$ .*

*Proof.* Let us prove the claim for the case where  $\text{dist}(u, v) = 2$  and  $u$  is the root of the  $A(\alpha + 1, 2\beta - 1)$  subtree and  $w = r$  (similar arguments hold for the other cases) and let us first assume that  $uw$  is the only edge of  $P(\alpha, \beta)$  that has label more than 1, say  $\ell(uw) = \alpha'$  where  $2 \leq \alpha' \leq \alpha$ . It follows that  $c_\ell(u) = \alpha + \alpha' + 1$  and that  $\alpha + 3 \leq c_\ell(u) \leq 2\alpha + 1$ . Since all edges of  $P(\alpha, 2\beta)$  except  $uw$  are labelled 1, each child  $y$  of  $u$  has  $c_\ell(y) = d(y)$ . Moreover, since  $u$  is the root of the  $A(\alpha + 1, 2\beta - 1)$  tree, each one of the  $\alpha + 1$  children of  $u$  has a unique degree in the set  $D(\alpha + 1)$ .



But  $D(\alpha + 1) = \{\alpha + 3, \dots, 2\alpha + 2\}$  and  $c_\ell(u) \in D(\alpha + 1)$ . It follows that there exists a child of  $u$  that has, by  $\ell$ , the same colour as  $u$ . Thus  $\ell$  must assign a label different from 1 to at least one more edge of  $P(\alpha, \beta)$ , and the argument can be repeated at least  $\beta$  times (since the height of  $T(\alpha, 2\beta)$  is  $2\beta + 1$ ), leading to  $\ell$  having to assign a label different than 1 to at least  $\beta$  edges. The exact value of  $\text{mE}(P(\alpha, 2\beta), \ell) = |E| + \beta$  is reached if each time the argument is repeated,  $\alpha' = 2$  and the next edge that gets assigned label 2 is at distance 2 from the previous ones.  $\square$

**Theorem 4.5.** *For every  $k \geq 2$ , there exists a nice graph  $T_k$  such that  $\text{mE}_{k+1}(T_k) < \text{mE}_k(T_k)$ .*

*Proof.* Let  $k \geq 2$  and let us describe the construction of  $T_k = (V, E)$ . For  $0 \leq j \leq k - 1$ , let  $P(k + j, 2(k + 1))$  be the auxiliary graph pending from  $v_j$  that corresponds to an auxiliary graph  $A(k + j, 2(k + 1))$  (represented by a vertex  $r_j$ ) and let  $u, v$  be two vertices connected by the edge  $uv$ . The tree  $T_k$  is the graph that is produced by identifying  $v$  with each one of the  $v_j$ . Observe that since  $r_j$  represents  $A(k + j, 2(k + 1))$ , each  $r_j$  has  $d(r_j) = k + j + 1$  in  $T_k$  and that the height of  $T_k$  is  $2(k + 1) + 1$ . Also observe that in  $T_k$ , since  $N(v) = \{r_0, \dots, r_{k-1}, u\}$ , we have  $d(v) = k + 1 = d(r_0)$ .

**Claim 4.6.** *There exists a proper  $(k + 1)$ -labelling  $\ell$  of  $T_k$  such that  $\sigma(\ell) = |E| + k$ .*

*Proof of the claim.* Note that  $T_k$  is almost locally irregular. Indeed, let  $w$  be a non-leaf vertex of  $T_k$  different from  $r_1, v$  and  $u$ , and let  $x$  be its parent. If  $d(w) = d + 1$ , then  $d + 1 > d(x)$  (by construction) and  $w$  has  $d$  children, each one having degree at least  $d + 2$ . In fact, the only adjacent vertices that have the same degree are  $v$  and  $r_0$ .

Let  $\ell$  be the  $(k + 1)$ -labelling of  $T_k$  that assigns label  $k + 1$  to the edge  $uv$  and label 1 to the remaining edges of  $T_k$ . Then  $c_\ell(v) = 2k + 1$  and, for each  $0 \leq i \leq k - 1$ , we have  $d(r_j) \in [k + 1, 2k]$  and thus there is no conflict between the colour of  $v$  and that of its children. It follows that  $\ell$  is a proper  $(k + 1)$ -labelling for  $T_k$  and  $\sigma(\ell) = |E| + k$ .  $\diamond$

Let  $\ell'$  be any proper  $k$ -labelling of  $T_k$ . It suffices to show that  $\sigma(\ell') > |E| + k$ . Note that, since  $d(v) = d(r_0) = k + 1$  and  $\ell'$  is proper, there must exist vertices  $w, y$ , with  $w \in N(r_0) \setminus \{v\}$  and  $y \in N(v) \setminus \{u, r_0\}$ , such that at least one of the edges  $uv, r_0w$  or  $vy$  has to have a label different from 1. Let  $\ell'(uv) = l$  with  $2 \leq l \leq k$  and assume that this is the only edge of  $T_k$  that has a label different from 1. Then  $c_{\ell'}(v) = k + l$  and  $k + l \in \{k + 2, \dots, 2k\}$ . Recall that for every  $0 \leq j \leq k - 1$ , vertex  $r_j$  has  $d(r_j) = k + j + 1$  and thus  $d(r_j) \in \{k + 1, \dots, 2k\}$ . Besides, since  $uv$  is the only edge with a label different from 1, we have  $c_{\ell'}(r_j) = d(r_j)$ . It follows that there exists a  $j \in \{0, \dots, k - 1\}$ , such that  $c_{\ell'}(r_j) = c_{\ell'}(v)$  leading to  $\ell'$  not being proper. Thus, there must exist another edge  $u'v'$  (with, say,  $u'$  being the parent of  $v'$ ) that is assigned a label different from 1 by  $\ell'$ . Note that  $u'$  is either  $r_j$  or  $v$ . This edge, however, belongs to  $P(q, 2(k + 1))$  (for some  $q \in \{k, \dots, 2k - 1\}$ ) and we have that  $1 \leq \text{dist}(v', v) \leq 2$ . It follows from Lemma 4.4 that  $\text{mE}(T_k) \geq |E| + k + 1$ . The cases where  $r_0w$  or  $vy$  are assigned a label different from 1 follow by applying directly Lemma 4.4.  $\square$

Observe that the height of  $T_k$  can be controlled by changing the  $\beta$  value of the pending auxiliary graphs that form it. Furthermore, for  $\alpha \geq 2$  and  $\beta, \beta' \in \mathbb{N}^*$  with  $\beta < \beta'$ , it follows from Lemma 4.4 that  $\text{mE}(T(\alpha, 2\beta)) < \text{mE}(T(\alpha, 2\beta'))$ , where  $T(\alpha, 2\beta)$  denotes the graph  $T_k$  formed by  $\alpha$  pending auxiliary graphs of height  $2\beta$ . This proves the following corollary:

**Corollary 4.7.** *For every  $k \geq 2$ , there exists a graph  $T_k$  such that  $\text{mE}_{k+1}(T_k)$  is arbitrarily smaller than  $\text{mE}_k(T_k)$ .*

## 5 Bounds

Observation 2.1 establishes that, for any nice graph  $G$ , in general  $\text{mE}(G)$  should be expressed as a function of  $|E|$ . To date, the best result towards the 1-2-3 Conjecture, due to Kalkowski, Karoński and Pfender [13], states that  $\chi_\Sigma(G) \leq 5$  holds for every nice graph  $G$ . It implies the following:

**Theorem 5.1** ([13]). *For every nice graph  $G$ , we have  $\text{mE}(G) \leq \text{mE}_5(G) \leq 5|E|$ .*

Of course, the upper bound in Theorem 5.1 is immediately improved for every nice graph  $G$  for which we can beat the upper bound of Kalkowski, Karoński and Pfender. In particular, let us recall that  $\chi_\Sigma(G) \leq 3$  whenever  $\chi(G) \leq 3$  (see [14]), which implies that  $\text{mE}(G) \leq \text{mE}_3(G) \leq 3|E|$  holds here. Recently, Przybyło proved in [18] that  $\chi_\Sigma(G) \leq 4$  whenever  $G$  is regular, which implies that  $\text{mE}(G) \leq \text{mE}_4(G) \leq 4|E|$  holds. More results of this sort can be found e.g. in the survey [19] by Seamone.

More generally, the 1-2-3 Conjecture, if true, would imply that, for every nice graph  $G$ , we even have  $\text{mE}(G) \leq \text{mE}_3(G) \leq 3|E|$ . A natural question to wonder is whether there exist graphs  $G$  for which  $\text{mE}(G)$  is close to this theoretical upper bound  $3|E|$ . Recall that, already, we have  $\text{mE}(G) \leq \text{mE}_2(G) \leq 2|E|$  whenever  $\chi_\Sigma(G) \leq 2$ . The fact that we are not aware of graphs  $G$  with  $\chi_\Sigma(G) = 3$  needing a lot of 3's in all proper 3-labellings leads us to suspect that even the following conjecture might be true.

**Conjecture 5.2.** *For every nice graph  $G$ , we have  $\text{mE}(G) \leq 2|E|$ .*

Conjecture 5.2 holds true for all graphs  $G$  with  $\chi_\Sigma(G) \leq 2$ , recall Observation 2.1. Experimentation via computer programs led us to observe that, actually, it might even be true that the equality  $\text{mE}(G) = 2|E|$  holds if and only if  $G$  is  $K_3$  or  $C_6$ , recall Theorems 2.5 and 2.6. However, these cases are very peculiar, due to the small number of edges these two graphs have.

Throughout this section, we provide weaker results towards Conjecture 5.2 for graphs with given chromatic number, we verify Conjecture 5.2 for bipartite graphs, and we prove a stronger result in the particular case of trees.

## 5.1 Graphs with large chromatic number

Towards Conjecture 5.2, we provide a general bound on  $\text{mE}(G)$  being a function of the chromatic number  $\chi(G)$ . In particular, the bound we get is better than that in Theorem 5.1, and even better than the conjectured one in Conjecture 5.2, for dense enough graphs.

In the upcoming proofs, we make use of arguments that are fairly common in this field (see e.g. [1, 6, 8, 14, 15, 16, 20]), based on label modifications along walks with certain parity length. Recall that a *walk* in a graph is a path in which vertices and/or edges might be repeated. A walk is said *closed* if it starts and ends at a same vertex. We say a path is *even* (*odd*, respectively) if it is of even length (odd length, respectively).

The next results are for graphs that are not bipartite. Results dedicated to bipartite graphs will be provided in the next section.

**Theorem 5.3.** *Let  $G = (V, E)$  be a nice connected graph with chromatic number  $k = \chi(G)$  at least 3. Then, we have  $\text{mE}(G) \leq \text{mE}_{k+1}(G) \leq |E| + k|V|$ .*

*Proof.* Since  $k \geq 3$ , we have that  $G$  is not a bipartite graph. It follows that there exists an odd cycle  $C$  in  $G$ . Let  $H$  be the subgraph of  $G$  constructed according the following procedure: start by  $H = C$ . Then, iteratively, for each vertex  $v \in V \setminus V(H)$  such that there exists a vertex  $h \in V(H)$  with  $vh \in E$ , add  $v$  to  $V(H)$  and  $vh$  to  $E(H)$ . Repeat this process until  $V(H) = V$ . In the end,  $H$  will contain only one cycle, the cycle  $C$ , and simple paths that lead to all the vertices of  $G$  that do not belong to  $C$ . Observe that for each  $e \in E(C)$ , the subgraph  $H - e$  is a spanning tree of  $G$ . Thus  $|E(H)| = |V(G)|$ .

Let  $G' = G \cup S_0$ , where  $S_0 = \emptyset$ , and  $S_i \subseteq V(G')$ , for  $1 \leq i \leq k$ , be the  $k$  stable sets induced by a proper vertex-colouring  $c$  of  $G'$  (i.e. if  $v \in S_i$  then  $c(v) = i$ ). We are going to construct a  $(k+1)$ -labelling  $\ell$  on the edges of  $G'$  such that  $\sigma(\ell) \leq |E(G')| + k|V(G')|$ . Let us start by having  $\ell$  assigning label 1 to all edges of  $G'$ . At this point, the colour of every vertex is exactly its degree. For each  $0 \leq i \leq k$ , let  $S_i^* = \{v \in S_i | c_\ell(v) = i \bmod k + 1\}$  (obviously  $S_0^* = \emptyset$ ). Our goal is to modify  $\ell$  so that for each  $i$ , we have  $S_i^* = S_i$ , from which it follows that  $c_\ell$  is a proper vertex-colouring of  $G'$ . Aiming at reaching that conclusion, note that, modulo  $k+1$ , we can equivalently have  $\ell$  assigning labels  $0, \dots, k$  instead.

Let  $v^* \in V(G')$  such that  $d(v) = d \bmod k + 1$ . Since  $c_\ell(v^*) = d(v^*)$ , it follows that  $v^* \in S_d^*$ . Free to relabel the stable sets induced by  $c$ , we may assume that  $d$  is such that  $S_{d-1} = \emptyset$ . For each  $v \in S_i \setminus S_i^*$ , we define  $P_o(v) = (v^*, h_1^o, \dots, h_n^o, v)$  and  $P_e(v) = (v^*, h_1^e, \dots, h_m^e, v)$  to be an

odd and an even walk, respectively, following the edges of  $H$ , that connect  $v^*$  and  $v$  (thus  $n$  is an even number and  $m$  is an odd number). These walks are sure to exist because  $H$  contains the odd cycle  $C$ . We modify  $\ell$  to a labelling  $\ell'$  as follows. We traverse  $P_o(v)$  from one end to the other, and, as going along, alternate between removing  $1 \bmod k+1$  and adding  $1 \bmod k+1$  from the labels of the traversed edges. Thus  $\ell'(v^*h_1^o) = \ell(v^*h_1^o) - 1 \bmod k+1$ ,  $\ell'(h_1^oh_2^o) = \ell(h_1^oh_2^o) + 1 \bmod k+1, \dots, \ell'(h_n^ov) = \ell(h_n^ov) - 1 \bmod k+1$ . We perform similar modifications as traversing  $P_e(v)$  from one end to the other. Thus  $\ell'(v^*h_1^e) = \ell(v^*h_1^e) + 1 \bmod k+1$ ,  $\ell'(h_1^eh_2^e) = \ell(h_1^eh_2^e) - 1 \bmod k+1, \dots, \ell'(h_m^ev) = \ell(h_m^ev) - 1 \bmod k+1$ . These modifications do not affect the colours of the internal vertices of  $P_o(v)$  and  $P_e(v)$ . We perform these modifications one after the other. That is, if we start by modifying  $P_o(v)$ , then we continue by modifying  $P_e(v)$ , next with modifying  $P_o(v)$ , and so on. Each time we modify  $P_o(v)$  or  $P_e(v)$ , the colour of  $v$  is reduced by  $1 \bmod k+1$  and if we alternate between modifying  $P_o(v)$  and  $P_e(v)$ , then the colour of  $v^*$  stays the same.

Let  $v \in S_i \setminus S_i^*$ . We alternate between modifying  $P_o(v)$  and  $P_e(v)$  until  $c_{\ell'}(v) = i \bmod k+1$ . Then we move on to modifying another vertex  $v' \in S_{i'} \setminus S_{i'}^*$  ( $i$  is not necessarily different from  $i'$ ). If the last modification for  $v$  was on  $P_o(v)$ , then we start with modifying  $P_e(v')$  and once more we proceed by alternating between modification on  $P_e(v')$  and  $P_o(v')$  and *vice versa*.

It is clear that once the above process is finished, for each  $v \neq v^*$  and  $i$ , we have  $v \in S_i$  if and only if  $c_{\ell'}(v) = i \bmod k+1$ . Also, if the total number  $w$  of modifications done is even, then  $c_{\ell'}(v^*) = d \bmod k+1$  and if  $w$  is odd, then  $c_{\ell'}(v^*) = d - 1 \bmod k+1$ . In any case, and since before the modifications we had  $S_{d-1} = \emptyset$ , the vertex-colouring  $c_{\ell'}$  of  $G$  is proper. Note that this remains true when turning all labels 0 into  $k+1$ , so that  $\ell'$  is a proper  $(k+1)$ -labelling as desired. Recall also that the modifications are done on the edges of  $H$  and  $|E(H)| = |V(G)|$ . In the worst case, all the edges of  $H$  are labelled  $k+1$  by  $\ell'$  and thus  $\text{mE}(G, \ell') \leq |E| + k|V|$ .  $\square$

In most proof contexts making use of the walk-switching procedure described in the proof of Theorem 5.3, there are favourable situations in which the bound can be further reduced. The next result illustrates that fact.

**Theorem 5.4.** *Let  $G = (V, E)$  be a nice connected graph with odd chromatic number  $k = \chi(G)$  at least 3. Then, we have  $\text{mE}(G) \leq \text{mE}_k(G) \leq |E| + (k-1)|V|$ .*

*Proof.* Let  $H$  be the subgraph of  $G$  as it was defined in the proof of Theorem 5.3 and  $S_i$  be the stable sets induced by a proper vertex-colouring  $c$  of  $G$ . Our goal is to reach, by  $\ell$ , the desired colours modulo  $k$ . Under that assumption, we can here assign labels  $0, \dots, k-1$  instead. Once more, we start with  $\ell$  assigning label 1 to all edges of  $G$ . For each  $1 \leq i \leq k$ , let  $S_i^* = \{v \in S_i \mid c_{\ell}(v) = i \bmod k\}$ .

For each  $v \in S_i \setminus S_i^*$ , let  $P_v$  be an odd-length closed walk of  $H$  that contains  $v$ . Again the existence of  $P_v$  is guaranteed because of  $C$ . We proceed by modifying the labels of  $P_v$ : we alternate between adding 1 (modulo  $k$ ) and removing 1 (modulo  $k$ ) from the labels of consecutive edges of  $P_v$ . Since  $P_v$  is a closed walk of odd length, exactly two consecutive edges (not necessarily distinct) will have to be altered in the same way (i.e., either they are both incremented by 1 or reduced by 1 modulo  $k$ ). The modification is done so that these two edges have  $v$  as a common vertex. Let  $\ell'$  be the modified  $\ell$  and let us assume that the labels of the edges of  $H$  that are adjacent to  $v$  are both incremented by 1 modulo  $k$  (symmetric arguments hold for the other case). Clearly  $c_{\ell'}(v) = c_{\ell}(v) + 2 \bmod k$  and since  $k$  is odd, by repeating this process the desired value  $c_{\ell'}(v) = i \bmod k$  is eventually reached.

Eventually turn all 0's into  $k$ 's. In the worst case,  $\ell'$  assigns label  $k$  on each one of the  $|V|$  edges of  $H$ . Thus  $\text{mE}(G, \ell') \leq |E| + (k-1)|V|$ .  $\square$

## 5.2 Bipartite graphs

In this section, we prove Conjecture 5.2 for nice bipartite graphs. It turns out, however, that we are not aware of many bipartite graphs  $G$  for which  $\text{mE}_3(G)$  reaches exactly  $2|E|$ . To go further, we both improve the upper bound in particular contexts, and exhibit constructions of connected bipartite graphs  $G$  with large value of  $\text{mE}_2(G)$ , that are legitimate candidates for having  $\text{mE}(G)$  large. Throughout this section, it is worth keeping in mind that determining  $\text{mE}_2(G)$  for a given bipartite graph  $G$  is  $\mathcal{NP}$ -complete by Theorem 3.2.

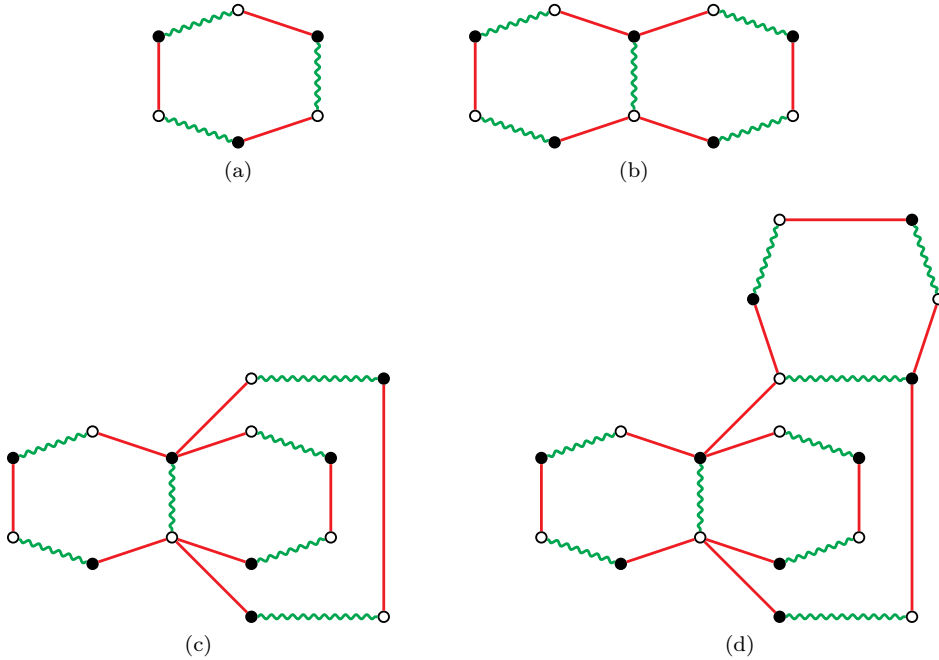

Figure 4: Constructing an odd multi-cactus through several steps, from the red-green  $C_6$  (a). Red-green paths with length at least 5 congruent to 1 modulo 4 are being repeatedly attached onto green edges through steps (b) to (d). Solid edges are red edges. Wiggly edges are green edges.

### 5.2.1 Conjecture 5.2 for nice bipartite graphs

Since, according to [14], nice bipartite graphs  $G$  verify the 1-2-3 Conjecture and some of them even verify  $\chi_\Sigma(G) = 3$ , they can be classified into three classes  $\mathcal{B}_1$ ,  $\mathcal{B}_2$  and  $\mathcal{B}_3$  where, for each  $i \in \{1, 2, 3\}$ , the set  $\mathcal{B}_i$  contains exactly the connected bipartite graphs  $G$  with  $\chi_\Sigma(G) = i$ . Note that  $\mathcal{B}_1$  contains the locally irregular bipartite graphs  $G$ , each one of which verifies  $\text{mE}_1(G) = |E|$ . The graphs  $G$  of  $\mathcal{B}_2$  admit proper 2-labellings, and, for these, by Observation 2.1 we have  $\text{mE}_2(G) \leq 2|E|$ . So, in order to prove Conjecture 5.2 for nice bipartite graphs, we only need to focus on the graphs of  $\mathcal{B}_3$ .

The graphs of  $\mathcal{B}_3$  were characterized by Thomassen, Wu and Zhang in [20], who proved that these graphs are exactly the so-called *odd multi-cacti*, which are the graphs that can be obtained at any step of the following procedure (see Figure 4 for an illustration):

- Start from a cycle with length at least 6 congruent to 2 modulo 4 whose edges are properly coloured with red and green (i.e., no two adjacent edges have the same colour).
- Consider a green edge  $uv$  and join  $u$  and  $v$  via a new path of length at least 5 congruent to 1 modulo 4 whose edges are properly coloured with red and green, where both the edge incident to  $u$  and the edge incident to  $v$  are red.

It is worth mentioning that odd multi-cacti are 2-degenerate and 2-connected. Also, they are bipartite, and both of their parts have odd size. It can also be noted that for every green edge  $uv$ , we have  $d(u) = d(v)$ , and no two green edges share ends. In [8], it was actually shown that any nice bipartite graph with a part of even size does not belong to  $\mathcal{B}_3$ :

**Lemma 5.5** ([8]). *Let  $G = (U, V, E)$  be a connected bipartite graph. If  $|U|$  is even, then  $\chi_\Sigma(G) \leq 2$ . Furthermore,  $G$  admits proper 2-labellings where all vertices of  $U$  have odd colour while all vertices of  $V$  have even colour.*

We are now ready to prove our main result in this section.

**Theorem 5.6.** *For every nice connected bipartite graph  $G$ , we have  $\text{mE}(G) \leq \text{mE}_3(G) \leq 2|E|$ .*

*Proof.* Since the statement holds for  $G \in \mathcal{B}_1 \cup \mathcal{B}_2$ , as explained earlier, we can assume  $G \in \mathcal{B}_3$ , i.e.,  $G$  is an odd multi-cactus with bipartition  $(U, V)$  (where both  $|U|$  and  $|V|$  are odd). If  $G$  is a cycle with length at least 6 congruent to 2 modulo 4, then the result follows from Theorem 2.6. Thus, we may assume that  $\Delta(G) \geq 3$ , i.e., some path attachments were made to build  $G$  starting from an original cycle.

Let us consider the last green edge  $xy$  to which a path  $P = (x, v_1, \dots, v_{4k}, y)$  was attached in the construction of  $G$ , where  $k \geq 1$ . Recall that  $d(x) = d(y) \geq 3$  by construction. Consider  $G' = G - \{v_1, v_2, v_3\}$ . Assuming  $v_1, v_3 \in U$  and  $v_2 \in V$ , the bipartition of  $G'$  is  $(U', V') = (U \setminus \{v_1, v_3\}, V \setminus \{v_2\})$ . This means that  $|V'|$  is even. By Lemma 5.5, there is a proper 2-labelling  $\ell'$  of  $G'$  such that all vertices of  $U'$  have even colour while all vertices of  $V'$  have odd colour. Since  $x \in V'$ , the colour  $c_{\ell'}(x)$  is odd, and thus at least 3 since  $d_{G'}(x) \geq 2$ . Similarly,  $v_4 \in V'$ , so the colour  $c_{\ell'}(v_4)$  is odd, and it is precisely 1 since  $d_{G'}(v_4) = 1$ .

We now extend  $\ell'$  to a proper 3-labelling  $\ell$  of  $G$ , by assigning label 1 to  $v_1v_2$ , label 2 to  $xv_1$  and  $v_3v_4$ , and label 3 to  $v_2v_3$ . This way:

- $c_\ell(x)$  and  $c_\ell(v_4)$  remain odd;
- $c_\ell(v_1) = 3 < 5 \leq c_\ell(x)$ ;
- $c_\ell(v_3) = 5 > 3 = c_\ell(v_4)$ ;
- $c_\ell(v_2) = 4 \notin \{c_\ell(v_1), c_\ell(v_3)\} = \{3, 5\}$ .

For these reasons, it should be clear that  $\ell$  is indeed proper. We additionally note that label 3 is actually assigned only once by  $\ell$ , to  $v_2v_3$ . Furthermore,  $\ell$  assigns label 1 at least once, e.g. to  $v_1v_2$ . From this, it follows that  $\sigma(\ell) \leq 2|E|$ .  $\square$

As mentioned earlier, the only connected bipartite graph  $G$  verifying  $\text{mE}(G) = 2|E|$  we are aware of, is  $C_6$ . Due to the small number of edges of  $C_6$ , this case looks quite pathological. In particular, it is natural to wonder whether Theorem 5.6 can be improved in general, when excluding  $C_6$ . We investigate this concern in what follows.

### 5.2.2 Lower bounds for some bipartite graphs

Our main result in this section is that, in general, for a nice connected bipartite graph  $G$  it is not possible to lower  $\text{mE}_2(G)$  below the  $\frac{3}{2}|E|$  barrier. Put differently, there exist connected bipartite graphs for which label 2 must be assigned to at least half of the edges by any proper 2-labelling. This is a consequence of the following more general result, which is of independent interest.

**Theorem 5.7.** *Let  $G$  be any nice connected graph, and let  $H$  be a graph obtained from  $G$  by subdividing every edge  $e$  exactly  $n_e$  times, where  $n_e = 4k_e + 3$  for some  $k_e \geq 0$ . Then  $\chi_\Sigma(H) = 2$ . Furthermore,  $\text{mE}_2(H) = \frac{3}{2}|E(H)|$ .*

*Proof.* For every edge  $e = uv$  of  $G$ , let us denote by  $P_e$  the corresponding path of length  $4(k_e + 1)$  in  $H$ . Note that  $H$  has many adjacent 2-vertices, so  $\chi_\Sigma(H) > 1$ . Also,  $H$  is bipartite with bipartition  $(X, Y)$ , where w.l.o.g.  $X$  contains all vertices of  $G$ . Now let  $\ell$  be the 2-labelling of  $H$  obtained by considering every edge  $e = uv$  of  $G$ , and assigning labels  $2, 1, 1, 2, 2, 1, 1, \dots, 1, 1, 2$  to the consecutive edges of  $P_e$  as going from  $u$  to  $v$ . Then  $\ell$  is proper since all vertices in  $X$  have even colour, while all vertices in  $Y$  have odd colour. The last part of the claim follows from the fact that for every edge  $e$  of  $G$ , in any labelling  $\ell$  of  $H$  every two edges of  $P_e$  being at distance 2 apart must receive distinct labels (recall Observation 2.3). Due to the length of  $P_e$ , this implies that the sum of the labels assigned to its edges is at least  $\frac{3}{2}|E(P_e)|$ . Thus,  $\sigma(\ell) \geq \frac{3}{2}|E(H)|$ .  $\square$

**Corollary 5.8.** *There exist infinitely many connected bipartite graphs  $G \in \mathcal{B}_2$  with various structure verifying  $\text{mE}_2(G) = \frac{3}{2}|E|$ . This remains true for trees.*

*Proof.* This follows from Theorem 5.7. The last part of the statement is because any subdivision of a tree is clearly a tree itself.  $\square$

In particular through experimentation via computer programs, we also managed to come up with the following construction yielding connected bipartite graphs  $G$  for which  $\text{mE}_2(G)$  slightly exceeds  $\frac{3}{2}|E|$ . These graphs can be constructed as follows. Let  $x, y \geq 4$  be any two integers congruent to 0 modulo 4. The graph  $H(x, y)$  is the graph obtained by starting from the disjoint union of a cycle  $C$  with length  $x$  and a cycle  $C'$  with length  $y$ , by adding an edge joining any vertex of  $C$  and any vertex of  $C'$ . Note that  $H(x, y)$  has odd size.

**Theorem 5.9.** *Let  $x, y$  be any two integers congruent to 0 modulo 4, with  $x, y \geq 4$ . Then, we have  $\text{mE}_2(H(x, y)) = \lceil \frac{3}{2}|E(H(x, y))| \rceil$ .*

*Proof.* We begin by showing the following claim:

**Claim 5.10.** *Let  $G$  be obtained from a cycle  $C$  with length  $x$  at least 4 congruent to 0 modulo 4 by adding an edge from any vertex  $v$  of  $C$  to a new pending vertex  $u$ . Then, by any proper 2-labelling  $\ell$  of  $G$ , exactly half of the edges of  $G$  must be labelled 2. Furthermore, either:*

- $\ell(vu) = 1$  and  $c_\ell(v) = 5$ , or
- $\ell(vu) = 2$  and  $c_\ell(v)$  can be either of 4, 5, 6.

*Proof of the claim.* Let us denote by  $v_0, \dots, v_{x-1}$  the successive vertices of  $C$ , where  $v_0 = v$ . Because  $d(v_i) = 2$  for every  $i \in \{1, \dots, x-1\}$ , recall, according to Observation 2.3, that, by any proper 2-labelling  $\ell$  of  $G$ , we must have  $\ell(v_0v_1) \neq \ell(v_2v_3) \neq \ell(v_4v_5) \neq \dots \neq \ell(v_{x-2}v_{x-1})$  (and thus, by the length of  $x$ , we have  $\ell(v_0v_1) \neq \ell(v_{x-2}v_{x-1})$ ), and similarly  $\ell(v_1v_2) \neq \ell(v_3v_4) \neq \ell(v_5v_6) \neq \dots \neq \ell(v_{x-1}v_0)$  (and thus  $\ell(v_1v_2) \neq \ell(v_{x-1}v_0)$ ). So there are essentially three ways for  $\ell$  to be designed:

- If  $\ell(v_0v_1) = \ell(v_0v_{x-1}) = 1$ , then  $\ell(v_1v_2) = \ell(v_{x-1}v_{x-2}) = 2$ , and  $c_\ell(v_1) = c_\ell(v_{x-1}) = 3$ . In that case, so that  $c_\ell(v_0) \neq 3$ , we must have  $\ell(v_0u) = 2$  in which case  $c_\ell(v_0) = 4$ .
- If  $\ell(v_0v_1) = \ell(v_0v_{x-1}) = 2$ , then  $\ell(v_1v_2) = \ell(v_{x-1}v_{x-2}) = 1$ , and  $c_\ell(v_1) = c_\ell(v_{x-1}) = 3$ . In that case, we can either have  $\ell(v_0u) = 1$  in which case  $c_\ell(v_0) = 5$ , or  $\ell(v_0u) = 2$  in which case  $c_\ell(v_0) = 6$ .
- If  $\ell(v_0v_1) = 1$  and  $\ell(v_0v_{x-1}) = 2$ , then  $\ell(v_1v_2) = 1$  and  $\ell(v_{x-1}v_{x-2}) = 2$ , and  $c_\ell(v_1) = 2$  and  $c_\ell(v_{x-1}) = 4$ . In that case, so that  $c_\ell(v_0) \neq 4$ , we must have  $\ell(v_0u) = 2$  in which case  $c_\ell(v_0) = 5$ .

This concludes the proof. ◇

Let  $G = H(x, y)$ , and  $\ell$  be a proper 2-labelling of  $G$ . Let  $H_1, H_2$  be the two connected components resulting from the removal of the unique bridge  $uv$  of  $G$ , and  $G_1$  and  $G_2$  be the subgraphs  $H_1 + uv$  and  $H_2 + uv$ , respectively, of  $G$  (where, say,  $G_1$  contains the cycle  $C_1$  with length  $x$ , and  $G_2$  contains the cycle  $C_2$  with length  $y$ ). Applying Claim 5.10 onto  $G_1$  and  $G_2$  and the restriction of  $\ell$  to these graphs, we deduce that we cannot have  $\ell(uv) = 1$  as otherwise we would have  $c_\ell(u) = c_\ell(v) = 5$ , a contradiction. So we must have  $\ell(uv) = 2$ . Furthermore, still by Claim 5.10, exactly half of the edges of  $C_1$  must be labelled 2 by  $\ell$ , and similarly exactly half of the edges of  $C_2$  must be labelled 2. It yields that  $\sigma(\ell) = \lceil \frac{3}{2}|E(H(x, y))| \rceil$ . Note that  $\ell$  does exist, since  $G$  is not an odd multi-cactus (due to the presence of the bridge  $uv$ ). In particular, the edges of  $C_1$  and  $C_2$  can be 2-labelled in such a way that  $c_\ell(u)$  and  $c_\ell(v)$  are two distinct values in  $\{4, 5, 6\}$ . □

### 5.2.3 Improved upper bounds

As shown previously, it seems that, in general, for nice connected bipartite graphs the bound in Theorem 5.6 might not be optimal. Following our investigations in the previous section, we believe that perhaps the following could be the right direction to investigate:

**Conjecture 5.11.** *There is an absolute constant  $c \geq 1$  such that, for every nice connected bipartite graph  $G \in \mathcal{B}_2$ , we have  $\text{mE}_2(G) \leq \frac{3}{2}|E| + c$ .*

It is worth pointing out that a proper 2-labelling  $\ell$  of a graph  $G$  where  $\sigma(\ell)$  is about  $\frac{3}{2}|E|$  is actually a 2-labelling where the number of assigned 1's is about the same as the number of assigned 2's. Thus, Conjecture 5.11 can be sort of related to the notion of *equitable proper labellings* of graphs, which were introduced in [3] and are proper labellings where, for every two assigned labels  $i, j$ , the number of edges assigned label  $i$  differs by at most 1 from the number of edges assigned label  $j$ . Regarding Conjecture 5.11, it can be observed that  $\text{mE}_2(G) \leq \frac{3}{2}|E| + 1$  holds for every graph  $G$  admitting an equitable proper 2-labelling. The additive  $c$  term is naturally reduced from 1 to 0 when  $G$  has even size. Among other results, the authors in [3] proved that nice bipartite complete graphs and forests admit equitable proper 2-labellings.

Towards Conjecture 5.11, in this section our aim is to improve Theorem 5.6 further for the bipartite graphs of  $\mathcal{B}_2$ . First off, we point out that the theoretical upper bound in Theorem 5.6 cannot be reached for a bipartite graph in  $\mathcal{B}_2$ .

**Observation 5.12.** *For every graph  $G \in \mathcal{B}_2$ , we have  $\text{mE}_2(G) < 2|E|$*

*Proof.* By definition of  $\mathcal{B}_1$ ,  $\mathcal{B}_2$  and  $\mathcal{B}_3$ , since  $G \notin \mathcal{B}_1$  the graph  $G$  is not locally irregular. Now, if  $\text{mE}_2(G) = 2|E|$ , then the only proper 2-labelling of  $G$  is the one assigning label 2 to all edges. For such a labelling to be proper,  $G$  must have no two adjacent vertices having the same degree. So  $G$  must be locally irregular, a contradiction.  $\square$

In particular contexts, better bounds can be obtained by adapting the arguments from the proof of Theorem 5.3 in a particular way.

**Theorem 5.13.** *Let  $G = (U, V, E)$  be a nice connected bipartite graph where  $|U|$  is even. Then, we have  $\text{mE}_2(G) \leq |E| + |V| - 1$ .*

*Proof.* Let us denote by  $U_e$  ( $U_o$ , respectively) the set of vertices of  $U$  having even (odd, respectively) degree in  $G$ , and similarly by  $V_e$  ( $V_o$ , respectively) the set of vertices of  $V$  having even (odd, respectively) degree in  $G$ . Note that either  $|U_e|$  and  $|V_o|$  must have the same parity, or  $|U_o|$  and  $|V_e|$  must have the same parity. This is because, otherwise, since  $|U|$  is even and  $|U| = |U_e| + |U_o|$ , the sizes  $|U_e|$  and  $|U_o|$  must have the same parity, we would get that also  $|V_e|$  and  $|V_o|$  have the same parity. From this, we would deduce that  $\sum_{u \in U} d(u) \not\equiv \sum_{v \in V} d(v) \pmod{2}$ , which is not possible.

Without loss of generality, we may assume that  $U_e$  and  $V_o$  have the same parity, thus that  $|U_e| + |V_o|$  is even. Our aim now, is to design a 2-labelling of  $G$  where all vertices in  $U$  get odd colour while all vertices in  $V$  get even colour. Such a labelling will obviously be proper. To that aim, we proceed as follows. Let us start with assigning label 1 to all edges of  $G$ . This way, at this point the colour of every vertex is exactly its degree; so all vertices in  $U_o$  and  $V_e$  verify the desired colour property, while all vertices in  $U_e$  and  $V_o$  do not. To fix these vertices, we consider any spanning tree  $T$  of  $G$ . We now repeatedly apply the following fixing procedure: we consider any two vertices  $x$  and  $y$  of  $U_e \cup V_o$  that remain to be fixed, and flip (i.e., turn the 1's into 2's, and *vice versa*) the labels of all edges on the unique path in  $T$  from  $x$  to  $y$ . This way, note that only the colours of  $x$  and  $y$  are altered modulo 2. Since  $|U_e| + |V_o|$  is even, there are an even number of vertices to fix, and, by flipping labels along paths of  $T$ , we can fix the colour of all vertices in  $U_e \cup V_o$ . This results in a 2-labelling  $\ell$  of  $G$ , with the desired properties, which is thus proper.

Note now that  $\ell$  assigns label 2 only to a subset of the edges of  $T$ . Since  $T$  has  $|V(G)| - 1$  edges, the result follows.  $\square$

Note for instance that, for a graph  $G$ , we have  $|E| + |V| - 1 \leq \frac{3}{2}|E|$  as soon as  $|E| \geq 2|V| - 2$ . As notable consequences, this implies that a connected bipartite graph  $G \in \mathcal{B}_2$  with a part of even size verifies  $\text{mE}_2(G) \leq \frac{3}{2}|E|$  as soon as  $G$  has minimum degree at least 4, or more generally when the graph is dense enough.

The same result also holds when  $G$  is bipartite and cubic (in which case  $\chi_\Sigma(G) = 2$ , by definition of odd multi-cacti), from a more general argument:

**Observation 5.14.** *Let  $G$  be a connected regular graph with  $\chi_\Sigma(G) = 2$ . Then, we have  $\text{mE}(G) \leq \text{mE}_2(G) \leq \frac{3}{2}|E|$ .*

*Proof.* Let  $\ell$  be a proper 2-labelling of  $G$ . Since  $G$  is regular, the edges labelled 1 by  $\ell$ , and similarly the edges labelled 2, must induce a locally irregular subgraph of  $G$ . Then the 2-labelling  $\ell'$  of  $G$  obtained by turning all 1's into 2's, and *vice versa*, is also proper. Now there is one of  $\ell$  and  $\ell'$  that assigns label 2 to at most half of the edges, and the conclusion follows.  $\square$

Slight modifications of the proof of Theorem 5.13 also yield the desired result for certain bipartite graphs that are Hamiltonian.

**Observation 5.15.** *Let  $G = (U, V, E)$  be a Hamiltonian bipartite graph where  $|U|$  is even. Then, we have  $\text{mE}(G) \leq \text{mE}_2(G) \leq \frac{3}{2}|E|$ .*

*Proof.* Just mimic the proof of Theorem 5.13, but repair pairs of defective vertices of  $G$  along a Hamiltonian cycle  $C = (v_0, \dots, v_{n-1}, v_0)$ , matching each of them, say, with the next defective vertex in the ordering of  $C$ . If this fixing process turns more than half of the edges to 2, then, instead, repair pairs of vertices around  $C$  matching each of them with the previous defective vertex in the ordering (which is equivalent to flipping the labels along  $C$ ).  $\square$

### 5.3 Trees

Our main result here is that for every nice tree  $T$ , we have  $\text{mE}_2(T) \leq \frac{3}{2}|E|$ , which cannot be lowered in general, due to Corollary 5.8. Still, it confirms Conjecture 5.11 for nice trees. Let us recall that it was proved in [3] that nice forests admit equitable proper 2-labelling. This directly implies our result below for trees with even size, while it does not for trees with odd size (as a 2-labelling where the number of assigned 2's is one more than the number of assigned 1's does not fulfil our claim).

**Theorem 5.16.** *For every nice tree  $T$ , we have  $\text{mE}_2(T) \leq \frac{3}{2}|E|$ .*

*Proof.* The proof is by induction on the number of branching vertices of  $T$ , where by branching vertex we mean any vertex of degree at least 3. The base case is when  $T$  has no branching vertex, i.e., when  $\Delta(T) \leq 2$ . In that case,  $T$  is a path. Let us here consider the 2-labelling  $\ell$  of  $T$  obtained by assigning labels 1, 1, 2, 2, 1, 1, 2, 2,  $\dots$  as traversing the edges from an end-vertex to the second one. It is easy to see that  $\ell$  is proper. Indeed, recall first that degree-1 vertices cannot be involved in a colour conflict. Furthermore, for two adjacent 2-vertices  $u, v$  to have the same colour, the edge incident to  $u$  different from  $uv$  must be assigned the same label as the edge incident to  $v$  different from  $uv$  (recall Observation 2.3). Since, by  $\ell$ , no two edges at distance 2 get assigned the same label, this implies that no colour conflict arises. Lastly, since 1's and 2's are assigned by pairs starting from a pair of 1's, it should be clear that  $\ell$  assigns more 1's than 2's. Thus,  $\text{mE}_2(T) \leq \sigma(\ell) \leq \frac{3}{2}|E|$ .

We now focus on the general case. That is, we now assume that  $T$  has branching vertices, and every nice tree with fewer branching vertices verifies the claim. Let us root  $T$  at some degree-1 vertex  $r$ . In the usual way, this defines a (virtual) orientation of  $T$ , where every vertex  $v$  of  $T$  but  $r$  has a unique *parent* (unique neighbour of  $v$  that is closer to  $r$ ), all vertices  $v$  but the leaves have *children* (neighbours of  $v$  that are farther from  $r$ ), and more generally all vertices  $v$  but the leaves have *descendants* (vertices where their unique shortest path to  $r$  passes through  $v$ ). By a *deepest branching vertex* of  $T$ , we refer to a branching vertex whose all descendants are not branching vertices, i.e., they have degree at most 2.

Let us consider a deepest branching vertex  $v$  of  $T$ . Then  $v$  is adjacent to its parent  $w$  and there are  $k \geq 2$  hanging paths  $P_1, \dots, P_k$  attached to  $v$ . Note that some of the  $P_i$ 's may be of length 1 in case some of the children of  $T$  are leaves. Let  $T'$  be the tree obtained from  $T$  by removing the edges of  $P_1, \dots, P_k$  (i.e., all their vertices different from  $v$ ). If  $T'$  is just an edge, then  $T$  is actually a subdivided star. If  $T$  is a star with at least two leaves, then it is locally irregular and we can assign label 1 to all edges. Otherwise, when  $T$  is a subdivided star different from a star, then, without loss of generality,  $P_1$  has length at least 2. We then change the root  $r$  to be the degree-1 vertex of  $P_1$  so that, now, we can assume that  $T'$  indeed is not an edge.

Thus, we can assume that  $T'$  is not just an edge. Since  $T'$  has less branching vertices than  $T$ , by the induction hypothesis there is a proper 2-labelling  $\ell'$  of  $T'$  verifying  $\text{mE}(T', \ell') \leq \frac{3}{2}|E(T')|$ .



We wish to extend  $\ell'$  to the edges of  $P_1, \dots, P_k$ , thus to a 2-labelling  $\ell$  of  $T$ . To that aim, we consider the following two extension schemes for extending  $\ell'$  to the edges of one  $P_x$  of the  $P_i$ 's:

- *1-extension*: We assign labels 1, 1, 2, 2, 1, 1, 2, 2,  $\dots$  to the consecutive edges of  $P_x$ , as they are traversed going from  $v$  to the degree-1 vertex of  $P_x$ .
- *2-extension*: We assign labels 2, 1, 1, 2, 2, 1, 1, 2, 2,  $\dots$  to the consecutive edges of  $P_x$ , as they are traversed going from  $v$  to the degree-1 vertex of  $P_x$ .

Note that whenever  $P_x$  has length not congruent to 1 modulo 4, the number of assigned 1's is always at least the number of assigned 2's by both 1-extensions and 2-extensions. More precisely, if  $P_x$  has length congruent to 1 modulo 4, then the number of 2's by a 2-extension is one more than the number of 1's, and *vice versa* by a 1-extension. Recall also that 1-vertices cannot be involved in colour conflicts. Furthermore, for two adjacent 2-vertices  $x, y$  to have the same colour, the edge incident to  $x$  different from  $xy$  must be labelled the same way as the edge incident to  $y$  different from  $xy$ . From this, we deduce that when extending  $\ell'$  to the edges of the  $P_i$ 's via 1-extensions and 2-extensions, we must just make sure that 1) the colour of  $v$  does not get equal to the colour of its parent  $w$ , and 2) the colour of  $v$  does not get equal to the colour of one of its children.

We note that the second type of colour conflict cannot actually occur. Indeed, note that by a 1-extension of  $P_x$ , the neighbour of  $v$  in  $P_x$ , unless it has degree 1 (in which case it cannot be in conflict with  $v$ ), gets colour 2, while, by a 2-extension, it gets colour 3. Since  $v$  is a branching vertex with  $k \geq 2$  children, thus of degree  $k + 1$ , when performing 1-extensions and 2-extensions to the  $P_i$ 's, vertex  $v$  gets colour precisely  $k + 1 \geq 3$  if only 1-extensions are performed, and colour at least  $k + 2 \geq 4$  if at least one 2-extension is performed.

Thus, we just need to find a combination of 1-extensions and 2-extensions to the  $P_i$ 's so that no colour conflict involving  $v$  and its parent  $w$  arises. Also, we need to make sure that the number of assigned 1's is at least the number of assigned 2's. If one of the  $P_i$ 's has length not congruent to 1 modulo 4, then we choose it as  $P_1$ . Otherwise, if they all have length congruent to 1 modulo 4, then we choose any  $P_i$  as  $P_1$ .

We first perform 1-extensions only, i.e., to all  $P_i$ 's. If the colour of  $v$  gets different from that of  $w$ , then we are done. Otherwise, when performing a 2-extension to  $P_1$  and a 1-extension to all other  $P_i$ 's, the colour of  $v$  gets bigger, thus getting different from the colour of  $w$ . This results in the desired extension  $\ell$  to all edges of  $T$ .

Let us conclude by noting that the number of 1's assigned by  $\ell$  is at least the number of assigned 2's. This is because  $\text{mE}_2(T', \ell) \leq \frac{3}{2}|E(T')|$ , and, as mentioned earlier, by 1-extensions to the  $P_i$ 's the number of assigned 1's is at least the number of assigned 2's. By 2-extensions, this is true when performed on paths of length not congruent to 1 modulo 4. By our choice of  $P_1$ , if  $P_1$  has length congruent to 1 modulo 4, then so do all  $P_i$ 's. In that precise case, the number of 2's assigned to the edges of  $P_1$  is one bigger than the number of assigned 1's, but this is compensated by the fact that, in  $P_2$ , the number of assigned 1's is one bigger than the number of assigned 2's. Thus we additionally have  $\sigma(\ell) \leq \frac{3}{2}|E(T)|$ , as desired.  $\square$

## 6 Conclusion

In this work, we have studied proper labellings of graphs with the additional requirement that we want the sum of assigned labels to be as small as possible. Our interests were guided by both straight questions, such as determining  $\text{mE}(G)$  for a given graph  $G$ , as well as more fundamental ones, such as the difference, in general, between  $\text{mE}_k(G)$  and  $\text{mE}_{k'}(G)$  for  $k \neq k'$ . We have also investigated the complexity of finding "optimal" labellings.

We quickly ran into Conjecture 5.2, which seems rather natural when knowing that the 1-2-3 Conjecture seems to be a more than plausible conjecture and that graphs, in general, seem to need only a few 3's to design proper 3-labellings. We believe it would be interesting to further study this point in the future, as Conjecture 5.2 stands as the main open problem regarding our investigations in the current paper. It would also be interesting to progress towards its refinement for bipartite graphs, Conjecture 5.11. A way to progress towards answering both questions could be to exhibit

families of connected (possibly bipartite) graphs  $G$  for which  $\text{mE}(G)$  is “large”, i.e. larger than the quantity in Theorem 5.9.

Regarding our algorithmic results in Section 3, we note that they all deal, for a given graph  $G$ , with the parameter  $\text{mE}_k(G)$  (for some  $k$ ), and not with the more general parameter  $\text{mE}(G)$ . This is mainly because, as indicated by Theorem 4.5, in general there is no absolute constant that bounds, for all graphs  $G$ , the smallest  $k$  such that  $\text{mE}(G) = \text{mE}_k(G)$ . In particular, even for a graph  $G$  of bounded treewidth, although we can determine  $\text{mE}_k(G)$  in polynomial time for any  $k$  (due to our algorithm in Theorem 3.5), running multiple iterations of our algorithm to determine  $\text{mE}(G)$  is not feasible in polynomial time. Thus, we leave the following problem open even for the seemingly simplest case:

**Question 6.1.** *What is the complexity of determining  $\text{mE}(T)$  for a given tree  $T$ ?*

## References

- [1] Baudon, O., Bensmail, J., Hocquard, H., Senhaji, M., Sopena, E.: Edge weights and vertex colours: Minimizing sum count. *Discrete Applied Mathematics* **270**, 13–24 (2019)
- [2] Baudon, O., Bensmail, J., Przybyło, J., Woźniak, M.: On decomposing regular graphs into locally irregular subgraphs. *European Journal of Combinatorics* **49**, 90–104 (2015)
- [3] Baudon, O., Piłśniak, M., Przybyło, J., Senhaji, M., Sopena, E., Woźniak, M.: Equitable neighbour-sum-distinguishing edge and total colourings. *Discrete Applied Mathematics* **222**, 40–53 (2017)
- [4] Bensmail, J., Fioravantes, F., Nisse, N.: On proper labellings of graphs with minimum label sum. In: L. Gasieniec, R. Klasing, T. Radzik (eds.) *Combinatorial Algorithms - 31st International Workshop, IWOCA 2020, Bordeaux, France, June 8-10, 2020, Proceedings, Lecture Notes in Computer Science*, vol. 12126, pp. 56–68. Springer (2020)
- [5] Bensmail, J., Li, B., Li, B., Nisse, N.: On Minimizing the Maximum Color for the 1-2-3 Conjecture. *Discrete Applied Mathematics* **289**, 32–51 (2021)
- [6] Bensmail, J., Mc Inerney, F., Lyngsie Szabo, K.: On  $\{a, b\}$ -edge-weightings of bipartite graphs with odd  $a, b$ . *Discussiones Mathematicae Graph Theory* p. To appear. (2019)
- [7] Bodlaender, H.L.: A partial  $k$ -arboretum of graphs with bounded treewidth. *Theoretical Computer Science* **209**(1), 1–45 (1998)
- [8] Chang, G., Lu, C., Wu, J., Yu, Q.: Vertex-coloring edge-weightings of graphs. *Taiwanese Journal of Mathematics* **15**, 1807–1813 (2011)
- [9] Chartrand, G., Erdős, P., Oellermann, O.: How to define an irregular graph. *The College Mathematics Journal* **19**, 36–42 (1998)
- [10] Chartrand, G., Jacobon, M., Lehel, J., Oellermann, O., Ruiz, S., Saba, F.: Irregular networks. *Congressus Numerantium* **64**, 197–210 (1986)
- [11] Diestel, R.: *Graph Theory*, 4th Edition, *Graduate texts in mathematics*, vol. 173. Springer (2012)
- [12] Dudek, A., Wajc, D.: On the complexity of vertex-coloring edge-weightings. *Discrete Mathematics and Theoretical Computer Science* **13**, 45–50 (2011)
- [13] Kalkowski, M., Karoński, M., Pfender, F.: Vertex-coloring edge-weightings: Towards the 1-2-3-conjecture. *Journal of Combinatorial Theory, Series B* **100**(3), 347–349 (2010)
- [14] Karoński, M., Łuczak, T., Thomason, A.: Edge weights and vertex colours. *Journal of Combinatorial Theory, Series B* **91**(1), 151–157 (2004)

- [15] Lu, H., Yu, Q., Zhang, C.Q.: Vertex-coloring 2-edge-weighting of graphs. *European Journal of Combinatorics* **32**(1), 21–27 (2011)
- [16] Lyngsie, K.S.: On neighbour sum-distinguishing  $\{0,1\}$ -edge-weightings of bipartite graphs (2017)
- [17] Mulzer, W., Rote, G.: Minimum-weight triangulation is NP-hard. *Journal of the ACM* **55** (2006)
- [18] Przybyło, J.: The 1-2-3 conjecture almost holds for regular graphs (2018)
- [19] Seamone, B.: The 1-2-3 conjecture and related problems: a survey (2012)
- [20] Thomassen, C., Wu, Y., Zhang, C.Q.: The 3-flow conjecture, factors modulo  $k$ , and the 1-2-3-conjecture. *Journal of Combinatorial Theory, Series B* **121**, 308–325 (2016)