



HAL
open science

Input redundancy: Definitions, taxonomy, characterizations and application to over-actuated systems

Jérémie Kreiss, Jean-François Tréguët

► To cite this version:

Jérémie Kreiss, Jean-François Tréguët. Input redundancy: Definitions, taxonomy, characterizations and application to over-actuated systems. *Systems & Control Letters*, 2021, 158, pp.105060. 10.1016/j.sysconle.2021.105060 . hal-03416534

HAL Id: hal-03416534

<https://hal.science/hal-03416534>

Submitted on 5 Nov 2021

HAL is a multi-disciplinary open access archive for the deposit and dissemination of scientific research documents, whether they are published or not. The documents may come from teaching and research institutions in France or abroad, or from public or private research centers.

L'archive ouverte pluridisciplinaire **HAL**, est destinée au dépôt et à la diffusion de documents scientifiques de niveau recherche, publiés ou non, émanant des établissements d'enseignement et de recherche français ou étrangers, des laboratoires publics ou privés.

Input Redundancy: Definitions, Taxonomy, Characterizations and Application to Over-Actuated Systems

Jérémie Kreiss^a, Jean-François Tréguët^b

^a *Université de Lorraine, CNRS, CRAN, F-54000 Nancy, France*

^b *Univ Lyon, INSA Lyon, Université Claude Bernard Lyon 1, Ecole Centrale de Lyon, CNRS, Ampère UMR5005, F-69621 Villeurbanne, France*

Abstract

For input redundant systems, it is possible to construct distinct inputs producing identical outputs, from the same initial state. Thus, a system is input redundant if it is not left-invertible. In this paper, a rigorous framework is proposed to support this new definition. From the observation that state trajectories induced by the two inputs can be identical or not, an enriched taxonomy of input redundancy is also designed. A comprehensive set of characterizations is associated with the proposed definitions. A degree of redundancy is also conceived. This allows to carry out a thorough comparison with the state-of-the-art. Finally, the fact that over-actuated systems are input redundant is formally proved. This fact leads to a control design framework which can easily cope with over-actuated systems equipped with dynamical actuators.

Keywords: Input-redundant systems, Over-actuated systems, Linear systems.

1. Introduction

Substituting a high-capacity actuator by several ones working in concert has many technological advantages: Examples include state-of-health and/or thermal management, resilience to failure, cost reduction, etc [1, 2, 3]. Such strategy hinges on the idea of creating a so-called *input redundant (IR) system*.

Historically, the property of IR¹ has been characterized by the existence of a non trivial null space of the input matrices. That is

$$\rho := \dim \text{Ker} \left\{ \begin{bmatrix} B \\ D \end{bmatrix} \right\} > 0, \quad (1)$$

when the considered dynamical system Σ is governed by the following equations

$$\dot{x}(t) = Ax(t) + Bu(t), \quad x(0) =: x_0, \quad (2a)$$

$$y(t) = Cx(t) + Du(t), \quad (2b)$$

*Corresponding author

¹Throughout this paper, IR stands either for “input redundancy” or for “input redundant” depending on the context.

5 for some quadruple (A, B, C, D) of appropriate dimensions. Here, vectors $u(t) \in \mathbb{R}^m$, $x(t) \in \mathbb{R}^n =: \mathcal{X}$ and $y(t) \in \mathbb{R}^p$ are the input, the state and the output at time t . Well surveyed in [1], most of the existing literature on IR relies on characterization (1).

However, (1) falls short in dealing with systems like the one associated with the following quadruple:

$$\left(\begin{bmatrix} -1 & 1 \\ 0 & -1 \end{bmatrix}, \begin{bmatrix} 1 & 0 \\ 0 & 1 \end{bmatrix}, \begin{bmatrix} 1 & 0 \end{bmatrix}, \begin{bmatrix} 0 & 0 \end{bmatrix} \right). \quad (3)$$

Even if (1) is not satisfied, it is clear that any of the two inputs *on its own* has enough authority to control the output. This suggests that this system shall be regarded as IR as well.

Define

$$G(s) := C(s\mathbf{I} - A)^{-1}B + D$$

as the transfer matrix of Σ . Whenever steady state arising from constant inputs is well-defined, i.e. $G^* := \lim_{s \rightarrow 0} G(s)$ is finite, systems like (3) motivate the introduction of inequality

$$\dim \text{Ker} \{G^*\} > 0, \quad (4)$$

as an alternative characterization of IR [4]. Indeed, it holds $G^* = \begin{bmatrix} 1 & 1 \end{bmatrix}$ for (3) so that this system is said *weakly* IR in [4], as opposed to *strongly* IR when (1) holds. Focusing on right-invertible, minimal and strictly proper systems, weak IR is re-characterized in [5] as follows:

$$m \geq \text{rank } B > p. \quad (5)$$

10 One can verify that this condition is satisfied for (3).

The key point is that (4) and (5) are not equivalent, so that definition of weak IR has implicitly changes from [4] to [5]. As formally stated in the sequel, (5) is related to left-invertibility, whereas (4) has to do with transmission zeros.

Often misunderstood, this crucial point impacts not only how dynamical system are classified but also
 15 how the related control problem is tackled. To see this, let us illustrate the discussion on system (3). In both [4] and [5], the proposed control strategy amounts to add a signal φ to y_c delivered by a given controller \mathfrak{C} designed beforehand, see Fig. 1. For system (3), one can define $y_c(t) = -x(t)$. One gets $u = \varphi + y_c$ where φ is designed by \mathfrak{A} to optimize some criterion, e.g. $\|u\|$, while being as much invisible as possible from the output y . This strategy aims preserving dynamical response induced by the first controller. Following
 20 [4], one defines $\varphi(t) = \begin{bmatrix} 1 \\ -1 \end{bmatrix} w(t)$ with w sufficiently slow. Observe that φ belongs to $\text{Ker} \{G^*\}$ so that internal steady state is smoothly reconfigured via w , without affecting the asymptotic value of y . However, φ inevitably affects the transient of y . This is in stark contrast with the control scheme proposed in [5] where $\varphi(t)$ is defined as $\begin{bmatrix} -x_2(t) \\ w(t) \end{bmatrix}$. In this case, not only w is made completely invisible from the output but also this signal can be selected *arbitrarily fast* while preserving internal stability. Although superior, this second

25 strategy cannot be implemented on all systems for which the first one is applicable. As shown in this paper, this originates from the fact that (4) does not implies (5).

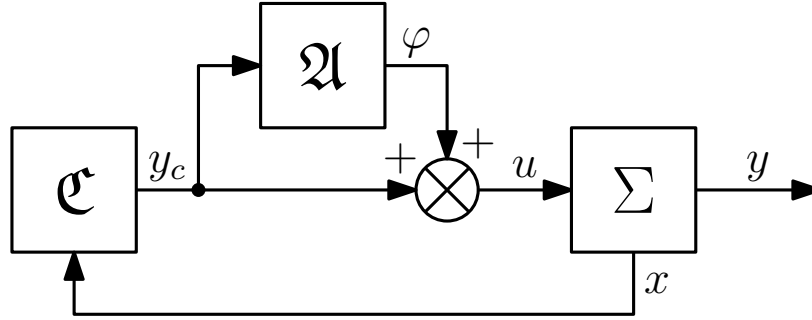

Figure 1: The control scheme used to illustrated differences between approaches proposed in [4] and [5].

Characterization of IR is therefore of utmost importance as it underpins the related control design strategy. For this reason, this paper aims setting the ground for further developments of control design for this class of systems by explicitly unveil relationships between existing characterizations of IR. This analysis is expected to clarify the implication behind the selection of a characterization, among a set of seemingly equivalent ones.

Among existing works, [5] is the closest to the framework that is promoted here. Yet, there is a number of issues that prevent this important study to receive the audience that it deserves. (i) Analysis is conducted under the assumption of right-invertibility, minimality and strict properness. Not only this makes the study less general, but also it does not help in fighting against widespread misconceptions which are only valid in this context. The main one is that $m > p$ is a necessary condition for LTI system to be IR. This paper provides an explicit counter example of this fact. (ii) In the context of right-invertible, minimal and strictly proper systems, the analysis hinges on the claim that dimension of a particular vector space \mathcal{V} , renamed \mathcal{N} hereafter, is equal to $m - p$. This technical fact is of foremost importance since it can be interpreted as the number of independent input directions (after regular state-feedback) which do not affect the output. In this paper, this result is formally proved and it is shown that this dimension cannot be computed from m , p and ρ in general. (iii) The retained taxonomy is quite misleading, since a system can be strongly but not weakly IR, which challenges common sense. For instance, quadruple $(0, [1 \ 1], 1, [0 \ 0])$ leads to $m = 2 \geq \text{rank } B = p = 1$, so that (5) does not hold, unlike condition $m > \text{rank } B = p$ characterizing strong IR in the sense of [5]. For this reason, a richer taxonomy is proposed here. It distinguishes between two kinds of weak redundancy that are different in nature.

Contributions are now in order. (i) The core idea of this paper is to redefine IR as the contrary of left-invertibility, i.e. for IR system, it is possible to construct distinct inputs producing identical outputs from the same initial state. In Sec. 2, a formal and unambiguous statement is associated to this intuitive

50 idea, which is widely applicable i.e. for a large class of system. Note that such a formulation was sometimes approached (see [5, p.4871] and [6, p.346]), but, to the best of our knowledge, no clear and rigorous statement can be found in the literature. (ii) Besides, this paper revisits and enriches the existing taxonomy of IR as well as introduces a new degree of IR by exploiting this new framework. (iii) The considered system is not necessarily right-invertible, stable, strictly proper, minimal or minimum phase. In this context, several 55 equivalent tractable characterizations of IR, its taxonomy and its degree are derived by way of a structural analysis adopting an open-loop view point and by exploiting existing characterizations of left-invertibility (see Sec. 3 and Sec. 4). (iv) This allows us to perform an in-depth comparison with existing definitions of IR and to unveil differences between them (see Sec. 5). (v) Closely related to IR, over-actuation refers to systems equipped of more effectors than strictly needed to meet the control objectives [1]. By relying on 60 previous characterizations, those two classes of systems are formally related in Sec. 6. This bridges the gap between two lines of research that are disconnected. As an example of the benefits of this achievement, a control design framework for over-actuated systems is offered, by exploiting results of this paper. Note that the considered actuators can be indifferently static or dynamic. This is in stark contrast with most of the existing results in the literature since the case of dynamical actuators is often considered as much more 65 challenging than static ones [7, Sec. 8.5].

Context of the study and notations. From (2a), the input-to-state relationship is concisely captured via $H_x[x_0; \cdot]$ which maps an input trajectory $u(\cdot)$ to the state trajectory $x(\cdot)$ produced by the system when excited by $u(\cdot)$ with an initial condition $x(0) = x_0 \in \mathbb{R}^n$. The corresponding input-to-output mapping $H[x_0; \cdot] : u \mapsto CH_x[x_0; u] + Du$ is defined by (2b).

70 Throughout this paper, inputs u are assumed to belong to \mathbf{U} , the set of causal, piecewise continuous and exponentially bounded signals. This ensures that the Laplace transform of u exists.

Let $x_0 \in \mathbb{R}^n$ be a given initial condition. The set of all triples (u, x, y) (resp. pairs (u, y)) *compatible for* x_0 is denoted by $\mathbf{Q}(x_0)$ (resp. $\mathbf{W}(x_0)$), i.e.

$$\mathbf{Q}(x_0) := \{(u, x, y) \mid H_x[x_0; u] = x, H[x_0; u] = y\},$$

$$\mathbf{W}(x_0) := \{(u, y) \mid \exists x : (u, x, y) \in \mathbf{Q}(x_0)\}.$$

Finally, note that symbol $\mathbf{0}$ stands for anything that is not a real number and is zero (a vector, matrix, map, or subspace), according to context. The identity matrix is denoted by \mathbf{I} . Given a set $\mathcal{A} \subseteq \mathbb{R}^n$ and a (not necessarily invertible or square) matrix B with n rows, the set $B^{-1}\mathcal{A}$ is defined as $\{u : Bu \in \mathcal{A}\}$.

75 2. Definitions and first properties

IR and its taxonomy is defined in this section.

2.1. Input redundancy

Definition. System Σ is *input redundant* (IR) if there exists an output y which can be produced by (at least) two distinct inputs for some $x_0 \in \mathcal{X}$, i.e. there exists $x_0 \in \mathcal{X}$ such that

$$\exists(u_1, y_1), (u_2, y_2) \in \mathbf{W}(x_0) : u_1 \neq u_2, y_1 = y_2. \quad (6)$$

Remark 1 (IR $\not\Leftarrow m > p$). Condition $m > p$ is often understood as a necessary condition for IR. Let us already provide a counter-example with that respect. Consider the following square system for which $m = p = 2$ holds:

$$\begin{aligned} \dot{x} &= \begin{bmatrix} -1 & 0 & 0 \\ 0 & -1 & 0 \\ 0 & 0 & -1 \end{bmatrix} x + \begin{bmatrix} 1 & 0 \\ 1 & 0 \\ 0 & 1 \end{bmatrix} u \\ y &= \begin{bmatrix} 1 & 0 & 0 \\ 0 & 1 & 0 \end{bmatrix} x. \end{aligned}$$

Then, IR follows from the observation that distinct input trajectories $u_1 : t \mapsto \mathbf{0}$ and $u_2 : t \mapsto \begin{bmatrix} 0 \\ 1 \end{bmatrix}$ produce output $y = \mathbf{0}$ for $x_0 = \mathbf{0}$. ┘

80 To prove that Σ is IR, it suffices to find a single output which admits at least two distinct preimages by $\mathbf{H}[x_0; \cdot]$ for some $x_0 \in \mathcal{X}$.² From linearity of \mathbf{H} , it can be easily proved that this singularity occur *for all* admissible outputs and *for all* initial states.

Proposition 2.1. *If system Σ is IR then it holds:*

$$\forall x_0 \in \mathcal{X}, \forall (u_1, y_1) \in \mathbf{W}(x_0), \exists (u_2, y_2) \in \mathbf{W}(x_0) : u_1 \neq u_2, y_1 = y_2.$$

Remark 2 (Left-invertibility). System Σ is said *left-invertible* if identical output trajectories can only originate from identical input trajectories, i.e. for all $x_0 \in \mathcal{X}$ and for all $u_1, u_2 \in \mathbf{U}$

$$\mathbf{H}[x_0; u_1] = \mathbf{H}[x_0; u_2] \Rightarrow u_1 = u_2. \quad (7)$$

Therefore, system Σ is IR if and only if Σ is *not* left-invertible. ┘

2.2. Taxonomy

85 In this section, the state trajectory comes into play. Indeed, the ability of distinct inputs to produce not only identical output but also identical state trajectory is instrumental in classifying different species of IR.

²This means that system Σ is IR if and only if $\mathbf{H}[x_0; \cdot]$ is *not* injective for some $x_0 \in \mathcal{X}$.

Let us now introduce state trajectories into (6):

$$\begin{aligned} \exists x_0 \in \mathcal{X}, \exists (u_1, x_1, y_1), (u_2, x_2, y_2) \in \mathbf{Q}(x_0) : \\ u_1 \neq u_2, x_1 = x_2, y_1 = y_2, \end{aligned} \quad (8)$$

$$\begin{aligned} \exists x_0 \in \mathcal{X}, \exists (u_1, x_1, y_1), (u_2, x_2, y_2) \in \mathbf{Q}(x_0) : \\ u_1 \neq u_2, x_1 \neq x_2, y_1 = y_2, \end{aligned} \quad (9)$$

Observe that if Σ is IR then at least one of the above relationships holds.

Definition. System Σ is input redundant (IR) of:

- The *first kind* if (8) holds but (9) does not, i.e., if and only if

$$\left. \begin{array}{l} u_1 \neq u_2 \\ y_1 = y_2 \end{array} \right\} \Rightarrow x_1 = x_2 \quad (10)$$

for all $x_0 \in \mathcal{X}$ and for all $(u_1, x_1, y_1), (u_2, x_2, y_2) \in \mathbf{Q}(x_0)$;

- The *second kind* if (8) does not hold but (9) does, i.e., if and only if

$$\left. \begin{array}{l} u_1 \neq u_2 \\ y_1 = y_2 \end{array} \right\} \Rightarrow x_1 \neq x_2 \quad (11)$$

holds for all $x_0 \in \mathcal{X}$ and for all $(u_1, x_1, y_1), (u_2, x_2, y_2) \in \mathbf{Q}(x_0)$;

- The *third kind* if (8) and (9) hold.

The previous definition induces that different kinds are mutually exclusive: No system Σ can be simultaneously of different kinds.

3. Characterizations

Let us now associate tractable conditions to definitions introduced in Sec. 2. To the end, define \mathcal{V}^* and \mathcal{R}^* as the *weakly unobservable subspace* and the *controllable weakly unobservable subspace*, respectively (see [8]).

3.1. Input redundancy

The following theorem, proved in Appendix A, proposes several characterizations of IR.

Theorem 3.1. Define ρ as in (1) and \mathcal{N} as follows:

$$\mathbb{R}^m \supseteq \mathcal{N} := B^{-1}\mathcal{V}^* \cap \text{Ker}\{D\}. \quad (12)$$

Then, the following statements are equivalent:

(i) System Σ is IR;

(ii) $\dim(\mathcal{R}^*) > 0$ or $\rho > 0$;

(iii) $\dim(\mathcal{N}) > 0$;

(iv) Transfer matrix $G(s)$ of Σ is not left-invertible, i.e. there exists a non zero polynomial vector q such
 105 that $G(s)q(s) = \mathbf{0}$ for all $s \in \mathbb{C}$;

(v) System matrix of Σ

$$P(s) := \begin{bmatrix} s\mathbf{I} - A & -B \\ C & D \end{bmatrix} \quad (13)$$

is not left-invertible.

Remark 3. Given a matrix $T(s)$, parametrized by $s \in \mathbb{C}$. Its *normal rank* is defined as follows:

$$\text{nrnk } T := \max_{s \in \mathbb{C}} \text{rank } T(s).$$

It comes out that (iv) and (v) of Th. 3.1 are equivalent to $\text{nrnk } G < m$ and $\text{nrnk } P < n+m$, respectively. \square

3.2. Taxonomy

Observe that $\text{Ker} \left\{ \begin{bmatrix} B \\ D \end{bmatrix} \right\}$ belongs to \mathcal{N} . The codimension of $\text{Ker} \left\{ \begin{bmatrix} B \\ D \end{bmatrix} \right\}$ in \mathcal{N} is denoted by ν :

$$\nu := \dim(\mathcal{N} / \text{Ker} \left\{ \begin{bmatrix} B \\ D \end{bmatrix} \right\}) \quad (14)$$

so that dimension of \mathcal{N} is the sum of two terms:

$$\dim \mathcal{N} = \rho + \nu, \quad (15)$$

where ρ is defined by (1). From this equation and (iii) of Th. 3.1, Σ is IR iff ρ or ν is strictly positive. As
 110 formalized by the following proposition proved in Appendix B, the kind of IR of Σ depends on which scalar
 (ρ or ν) is non zero.

Proposition 3.2. Define ρ and ν as in (1) and (14). The kind of redundancy of Σ is characterized by ρ and ν , as in the following table:

IR	ρ	ν
1st kind	> 0	$= 0$
2nd kind	$= 0$	> 0
3rd kind	> 0	> 0

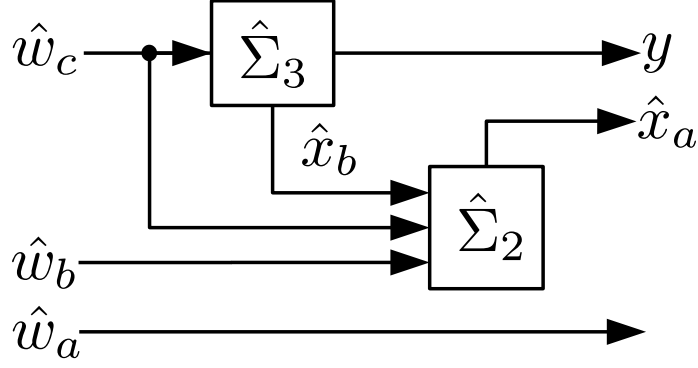

Figure 2: Internal structure of Σ with feedback transformation.

From (15), note that the following equivalence readily follows by rewriting (ii) of Th. 3.1 as $\rho + \dim(\mathcal{R}^*) > 0$:

$$\dim \mathcal{R}^* > 0 \Leftrightarrow \nu > 0. \quad (16)$$

115 This relationship makes Prop. 3.2 more convenient since $\dim \mathcal{R}^*$ is typically easier to compute than ν .³

4. Degree of redundancy and additional facts

Further discussions are provided in this section, leading to a degree of IR.

4.1. A matrix view point

Define $Q = [Q_a, Q_b] \in \mathbb{R}^{n \times n}$ and $H = [H_a, H_b, H_c] \in \mathbb{R}^{m \times m}$ two invertible matrices satisfying $\text{Im} \{Q_a\} = \mathcal{R}^*$, $\text{Im} \{H_a\} = \text{Ker} \left\{ \begin{bmatrix} B \\ D \end{bmatrix} \right\}$ and $\text{Im} \{[H_a, H_b]\} = \mathcal{N}$. Given any friend⁴ F of \mathcal{V}^* , apply feedback transformation $u = Fx + w$ to Σ and changes of coordinates $\hat{w} = H^{-1}w$ and $\hat{x} = Q^{-1}x$. Matrices of the resulting quadruple $(Q^{-1}(A + BF)Q, Q^{-1}BH, (C + DF)Q, DH)$ with input \hat{w} , state \hat{x} and output y has the following structure:

$$\left[\begin{array}{cc|ccc} A_{11} & A_{12} & \mathbf{0} & B_{12} & B_{13} \\ \mathbf{0} & A_{22} & \mathbf{0} & \mathbf{0} & B_{23} \\ \hline \mathbf{0} & C_2 & \mathbf{0} & \mathbf{0} & D_3 \end{array} \right]. \quad (17)$$

Further, let (i) \hat{w} be decomposed into $\hat{w}_a(t) \in \mathbb{R}^\rho$, $\hat{w}_b(t) \in \mathbb{R}^\nu$ and $\hat{w}_c(t) \in \mathbb{R}^{m-\rho-\nu}$, (ii) \hat{x} be decomposed into $\hat{x}_a(t) \in \mathbb{R}^{\dim \mathcal{R}^*}$ and $\hat{x}_b(t) \in \mathbb{R}^{n-\dim \mathcal{R}^*}$ and (iii) $\hat{\Sigma}_2$ and $\hat{\Sigma}_3$ be associated with quadruple $(A_{11}, [A_{12}, B_{13}, B_{12}], \mathbf{0}, \mathbf{0})$ and $(A_{22}, B_{23}, C_2, D_3)$, respectively. Then, relationship between signal is depicted by Fig. 2. Sparsity of matrices of (C.1) betrays the cascaded structure of this scheme. It highlights that output y is independent of both \hat{w}_a and \hat{w}_b .

³Let us emphasize that $\dim \mathcal{R}^*$ and ν are by no means equal, in general.

⁴Recall that a F is a *friend* of \mathcal{W} if $(A + BF)\mathcal{W} \subseteq \mathcal{W}$ holds.

Involved subsystems enjoy the following property: Pair (A_{11}, B_{12}) of $\hat{\Sigma}_2$ is controllable and $\hat{\Sigma}_3$ is left-invertible (see [9, p.170]). As a result, input \hat{w}_c is uniquely defined by pair (x_0, y) , unlike \hat{w}_a and \hat{w}_b . Hence, \hat{w}_c corresponds to part of the input w which is fixed by (x_0, y) . As a possible control purpose, $\hat{w}_{a,b}$ can be used to minimize the input norm and/or to drive coordinate \hat{x}_a toward a relevant reference, see [6]. Fig. 2 clarifies why \mathcal{N} , in which $\hat{w}_a(t)$ and $\hat{w}_b(t)$ belongs to, is sometimes called “input unobservability subspace”.

4.2. Degree of redundancy and computation of $\dim \mathcal{N}$

From the above discussion, the scalar $\dim \mathcal{N} = \rho + \nu$ corresponds the number of independent input directions (after regular state-feedback with any friend of \mathcal{V}^*) which do not affect the output. Specifically, ρ of them do not affect the state whereas ν impact the state. As a result, $\dim \mathcal{N}$ is related to the size of the set of all inputs leading to the same output. This motivates the use of ρ and ν to quantify the degree of IR.

Definition. The pair (ρ, ν) , defined by (1) and (14), is called *degree of redundancy* of system Σ .

Next lemma, proved in Appendix C, offers an efficient way to compute $\dim \mathcal{N} = \rho + \nu$.

Lemma 4.1. *It holds*

$$\dim \mathcal{N} = n + m - \text{nrnk } P. \quad (18)$$

4.3. If Σ is right-invertible

The following corollary particularizes the previous results under the assumption of right-invertibility, which can be characterized via $\text{nrnk } P = n + p$ [8, Th. 8.13].

Corollary 1. *Assume that Σ is right-invertible. It holds*

$$\dim \mathcal{N} = m - p, \quad (19)$$

so that Σ is IR iff $m > p$ holds.

Combined with Prop. 3.2 and (15), this corollary allows to conclude on the kind of IR on the basis of values of m , p and ρ solely.

5. Comparison with the literature

In the last decade, several definitions, characterizations and taxonomies of IR have been proposed in the literature. Let us relate the material of [4, 5, 10] with contents presented in previous sections.

Hereafter, without further details, *IR (of the k -th kind)* refers to definition proposed in Sec. 2 and 3. The symbols \mathcal{P} and \mathcal{Z} represent the sets of poles and zeros (transmission zeros) of G , respectively.

5.1. Comparison with [4]

For the first time in the literature, a taxonomy of IR has been proposed in [4].

[4] : System Σ is said *strongly IR* if $\rho > 0$ and *weakly IR* if $G^* := \lim_{s \rightarrow 0} G(s)$ is finite and satisfies
 $\text{Ker} \{G^*\} \neq \{\mathbf{0}\}$.

The following equivalence immediately derives from Th. 3.1 and Prop. 3.2:

$$\begin{array}{l} \text{IR 1st kind} \\ \text{or 3rd kind} \end{array} \Leftrightarrow \text{strong IR as in [4].}$$

Let us focus on weak redundancy in the sense of [4]. Observe that G^* is finite iff $0 \notin \mathcal{P}$ holds.⁵ In this case and in view of Rem. 3, IR implies $\text{rank } G^* \leq \text{nrank } G < m$. This yields:

$$\text{IR} \xrightarrow{0 \notin \mathcal{P}} \begin{array}{l} \text{weak (and possibly strong)} \\ \text{IR as in [4].} \end{array} \quad (20)$$

Focusing on redundancy of the 2nd kind where $\rho = 0$, we also have:

$$\text{IR 2nd kind} \xrightarrow{0 \notin \mathcal{P}} \begin{array}{l} \text{weak but not strong} \\ \text{IR as in [4].} \end{array}$$

Let us emphasize that the proposed definition applies even if 0 belongs to \mathcal{P} . As an example, the quadruple $(\mathbf{0}, \mathbf{I}_2, [1 \ 1], \mathbf{0})$ is associated with an IR system which is neither strong nor weak IR as in [4]. Indeed, in this case, matrix $G(s) = (1/s)[1 \ 1]$ is neither left-invertible (which proves IR) nor finite when s tends to 0, and ρ equals zero.

The next example shows that the converse implication of (20) does not hold, i.e. IR cannot be inferred from weak IR as in [4].

Example 1. Consider the following system

$$\begin{aligned} \dot{x} &= -x + u, \\ y &= -x + u. \end{aligned}$$

so that $G(s) = s/(s + 1)$ holds. Therefore, the system is weakly IR in the sense of [4], since $G(0) = 0$. Yet, $G(s)$ is invertible (and a fortiori left-invertible), so that this system is *not* IR: For a given initial state, identical outputs can only originate from identical inputs. \lrcorner

⁵Clearly if $0 \notin \mathcal{P}$, then strong IR implies weak IR since $\text{Ker} \left\{ \begin{bmatrix} B \\ D \end{bmatrix} \right\} \subseteq G^*$ holds. The converse implication is not true in general.

The previous example shows that $G(s)$ can lose rank for some specific s , even if $\text{nrank } G$ equals m , i.e. $\text{rank } G^* < m$ does not imply $\text{nrank } G < m$. Those value of s satisfying $\text{rank } G(s) < \text{nrank } G$ are the transmissions zeros. As a result, if $0 \notin \mathcal{Z}$ holds, then weak IR as in [4] implies $\text{nrank } G = \text{rank } G^* < m$, so that:

$$\text{IR} \stackrel{0 \notin \mathcal{Z}}{\Longleftarrow} \text{weak IR as in [4].}$$

160 To sum up, the proposed definition is more general in the sense that it can be applied regardless of \mathcal{P} . The proposed taxonomy is also richer as it distinguishes between two kinds of strong redundancy as in [4] (that is IR of the 1st and 3rd kind) which are different in nature.

5.2. Comparison with [5]

The taxonomy of [4] is revisited in [5] under the following assumption.

165 **Assumption 1.** Σ is minimal, strictly proper and right-invertible, so that $\text{rank } C = p$ holds. △

[5] : Under ASM 1, *strong IR* means $m > \text{rank } B = p$ whereas *weak IR* means $m \geq \text{rank } B > p$.

IR as in [5] is therefore implicitly characterized by $m > p$. It follows that this condition is equivalent to IR as proved by Cor. 1:

$$\text{IR} \stackrel{\text{ASM } 1}{\Longleftrightarrow} \text{IR as in [5].}$$

Suppose that Σ is IR and that ASM 1 holds. From Cor. 1, $\text{rank } \begin{bmatrix} B \\ D \end{bmatrix} = \text{rank } B = m - \rho > p$ is equivalent to $\nu > 0$ and, in turn, to IR of the 2nd or 3rd kind:

$$\begin{array}{l} \text{IR 2nd} \\ \text{or 3rd kind} \end{array} \stackrel{\text{ASM } 1}{\Longleftrightarrow} \text{weak IR as in [5].}$$

On the contrary,⁶ $\text{rank } B$ equals p , which is equivalent to $\nu = 0$ in view of (19) and, therefore, to IR of the 1st kind:

$$\text{IR 1st kind} \stackrel{\text{ASM } 1}{\Longleftrightarrow} \text{strong IR as in [5].}$$

Example 2. Consider the system associated with the quadruple $(\begin{bmatrix} -1 & 0 \\ -1 & -1 \end{bmatrix}, \begin{bmatrix} 1 \\ 1 \end{bmatrix}, [0 \ 1], 0)$, which satisfies ASM 1. One can check that $G(s) = s/(s+1)^2$ so that this system is weakly IR in the sense of [4], but not in that of [5]. ┘

170 Summarizing, the proposed definition is more general in the sense that it applies to any proper system, i.e. ASM 1 is not required. In Cor. 1, we also demonstrate that the right-invertibility is the key to prove IR of Σ from the inequality $m > p$, i.e. minimality and strict properness required by ASM 1 can be dismissed.

⁶From (19), it holds $\neg(\text{rank } \begin{bmatrix} B \\ D \end{bmatrix} > p) \Leftrightarrow \text{rank } \begin{bmatrix} B \\ D \end{bmatrix} = p$.

The proposed taxonomy also refines that of [5] by distinguishing two kinds of weak redundancy, that is IR of the 2nd and 3rd kind. Finally, we exhibit distinctions between seemingly equivalent definitions in the literature, by providing an example which is weakly IR in the sense of [4], but not in that of [5].

Remark 4. In [5], the discussion focuses on $\mathcal{V} := B^{-1}\mathcal{R}^*$ instead of \mathcal{N} . If Σ is strictly proper, these subspaces are actually identical since

$$\mathcal{N} = B^{-1}\mathcal{R}^* \cap \text{Ker}\{D\} \quad (21)$$

holds. To prove (21), observe that $B^{-1}\mathcal{R}^* \cap \text{Ker}\{D\}$ is trivially included in $B^{-1}\mathcal{V}^* \cap \text{Ker}\{D\}$ since $\mathcal{R}^* \subseteq \mathcal{V}^*$. Conversely, given any friend F of \mathcal{V}^* , it is known that \mathcal{R}^* is the smallest $(A + BF)$ -invariant subspace containing $\mathcal{V}^* \cap B\text{Ker}\{D\}$ [8, Th. 7.14]. Thus, $\mathcal{R}^* \supseteq \mathcal{V}^* \cap B\text{Ker}\{D\}$ holds. Intersecting both side by $B\text{Ker}\{D\}$ and applying map B^{-1} yields $B^{-1}(\mathcal{R}^* \cap B\text{Ker}\{D\}) \supseteq B^{-1}(\mathcal{V}^* \cap B\text{Ker}\{D\})$. This is equivalent to $B^{-1}\mathcal{R}^* \cap B^{-1}B\text{Ker}\{D\} \supseteq B^{-1}\mathcal{V}^* \cap B^{-1}B\text{Ker}\{D\}$ which reduces to $B^{-1}\mathcal{R}^* \cap \text{Ker}\{D\} \supseteq B^{-1}\mathcal{V}^* \cap \text{Ker}\{D\}$ since $B^{-1}B\text{Ker}\{D\} = \text{Ker}\{D\}$. \lrcorner

5.3. Comparison with [10]

The characterization and taxonomy of IR proposed in [4] is implicitly revisited in [10] under the assumption of right-invertibility.⁷

Instead of referring to the transfer matrix G , [10] focuses on the system matrix P , defined in (13). For some $\omega \in \mathbb{R}_{\geq 0}$, a matrix N_ω satisfying $\text{Im}\{N_\omega\} = \text{Ker}\{P(j\omega)\}$ is called *IR matrix basis at frequency ω* . Clearly, $\text{rank } N_\omega$ is non zero if $\text{rank } P(j\omega) < n + m$ holds. In view of Rem. 3, the following implication is valid for all $\omega \in \mathbb{R}_{\geq 0}$:

$$\text{IR} \implies \text{rank } N_\omega > 0.$$

The converse implication requires an additional assumption:

$$\text{IR} \xleftarrow{\mathcal{Z}_P} \text{rank } N_\omega > 0,$$

where \mathcal{Z}_P refers to set of invariant zeros of Σ , i.e. the values of s for which $P(s)$ loses rank:

$$\mathcal{Z}_P := \{s \in \mathbb{C} \mid \text{rank } P(s) < \text{nrank } P\}. \quad (22)$$

Indeed, the invariant zeros on the imaginary axis might prevent IR to be inferred from the rank of N_ω , as shown in the following example.

Example 3 (Ex. 1 continued). For this system, $P(s)$ equals $\begin{bmatrix} s+1 & -1 \\ -1 & 1 \end{bmatrix}$. It follows that $\text{nrank } P = n + m = 2$ and $\mathcal{Z}_P = \{0\}$, so that $\text{rank } N_0 = 1 > 0$ holds for this non IR system. \lrcorner

⁷In [10, ASM. 3], it is assumed that there exists $\lambda \in \mathbb{C}$ such that $\text{rank } P(\lambda) = n + p$. In this case, $\text{nrank } P = n + p$ holds which implies right-invertibility of Σ .

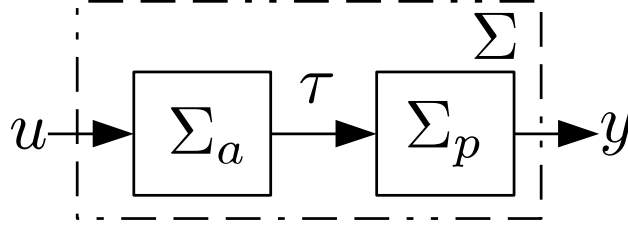

Figure 3: Over-actuated system Σ .

In [10, Def. 1], a degree of redundancy is proposed. Defining $\mu := m - p - \rho$, Σ is said ρ -strongly (equivalently, μ -weakly) IR or simply strongly (resp. weakly) IR if it is 0-weakly (resp. 0-strongly) IR. If Σ is right-invertible, Cor. 1 applies and shows that μ equals ν . Thus, strongly (resp. weakly) IR as in [10] refers to 1st kind (resp. 2nd kind), whereas ρ -strongly or μ -weakly corresponds 3rd kind as soon as both ρ and $\mu = \nu$ are non zero.

As compared to [10], the definition of the degree of input-redundancy given in this paper can be regarded as a generalization to non right-invertible system for which $\dim \mathcal{N}$ cannot be computed from ρ and the dimensions of the system. If Σ is right-invertible, we also formally prove that $\mu + \rho = \nu + \rho = m - p$ independent input directions exist (after regular feedback) which do not affect the output, see Subsec. 3.2. In general, the number of those inputs depends not only on the dimensions of the system but also on the normal rank of the system matrix, see Lem. 4.1.

6. How to control over-actuated systems ?

By relating over-actuated systems to IR, the internal structure of those systems is exploited to derive a natural control design framework.

6.1. Over-actuation implies input redundancy

System Σ is *over-actuated* if Σ can be decomposed into a set of actuators gathered in an *IR subsystem* Σ_a in series with the plant Σ_p , see Fig. 3. Overall control effort τ is delivered by Σ_a and drives Σ_p which produces y . Indeed, over-actuation is naturally translated by the existence of some trajectory τ which can be produced by way of distinct input trajectories u . This means that Σ_a is input redundant.

Let (A_a, B_a, C_a, D_a) be the quadruple associated with Σ_a . Denote its controllable weakly unobservable subspace by \mathcal{R}_a^* . Besides, let us simplify the analysis by assuming that output y uniquely determines τ , i.e. Σ_p is left-invertible.

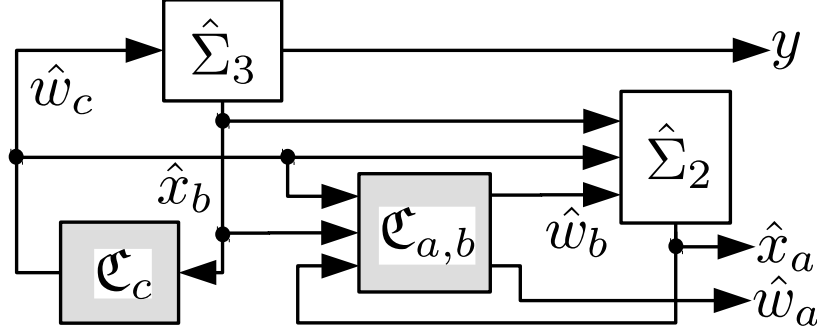

Figure 4: Control scheme of over-actuated system Σ .

Proposition 6.1. *Assume that Σ_p is left-invertible and that Σ_a is input redundant of the k -th kind. It holds*

$$\text{Ker} \left\{ \begin{bmatrix} B \\ D \end{bmatrix} \right\} = \text{Ker} \left\{ \begin{bmatrix} B_a \\ D_a \end{bmatrix} \right\}, \quad (23)$$

$$\mathcal{R}^* = \mathcal{R}_a^* \oplus \{\mathbf{0}\}, \quad (24)$$

so that over-actuated system Σ is input redundant of the k -th kind.

Proof. See Appendix D. □

Let assumptions of Prop. 6.1 hold. From Prop 3.2 and (16), it immediately follows that if Σ_a is static, i.e. $\tau = D_a u$, then Σ_a and, in turn Σ , are IR of the first kind. Similarly, if Σ_a is purely dynamical, i.e. $D_a = \mathbf{0}$ and $\text{Ker} \{B_a\} = \{\mathbf{0}\}$, then Σ_a and Σ are IR of the second kind.

6.2. A straightforward control scheme

Prop. 6.1 allows to perform decomposition of Σ introduced in Subsec. 4.1 in a straightforward way. One ends up with conceptual scheme depicted on Fig 2. Since \hat{w}_a and \hat{w}_b are invisible from the output, they can be arbitrarily selected. This naturally leads to the modular controller colored in gray on Fig. 4: Control of y is handled by \hat{w}_c via \mathcal{C}_c , while \hat{w}_a and \hat{w}_b are produced via $\mathcal{C}_{a,b}$. Typically, those last two signals aims driving \hat{x}_a to a specific reference (possibly defined online) and making $u = Fx + H\hat{w}$ comply with input constraints, see e.g. [11, 12].

7. Conclusions and final remarks

The proposed definition and taxonomy of IR are formulated in terms of input/state/output signals. In addition of being more intuitive than existing characterizations (see Sec. 5), such a formulation is intended for direct extension, out of the class of unconstrained, proper, finite dimensional, linear, continuous time and time-invariant systems considered in this paper. Any of those adjectives leads to a possible extension of this work, where proposed definition of IR needs to be characterized in a more general context.

Appendix A. Proof of Th. 3.1

230 The equivalence between (iv) and IR of Σ can be proved by straightforward adaptation of the proof of [8, Th. 8.8] to the context of this paper where \mathbf{U} does not contain impulsive-smooth distributions. By [8, Th. 8.8], (iv) is equivalent to saying that Σ is not left-invertible (in the classical sense of [8, Def. 8.7]), so that [8, Th. 8.26] and [8, Cor. 8.10] apply and prove (i) \Leftrightarrow (ii) and (i) \Leftrightarrow (v), respectively. Regarding (iii), observe that if $\rho = 0$, then (i) \Leftrightarrow (iii) holds as proved in [9, Lem. 3]. On the contrary, if $\rho > 0$ so that (ii) 235 holds and Σ is input-redundant, then (iii) is valid as well since $\text{Ker} \left\{ \begin{bmatrix} B \\ D \end{bmatrix} \right\} \subseteq \mathcal{N}$ holds.

Appendix B. Proof of Prop. 3.2

From linearity of H , Σ is IR of 1st kind (resp. 2nd kind) iff (B.1) (resp. (B.2)) holds:

$$\forall (u, x, y) \in \mathbf{Q}^*(\mathbf{0}), \quad (y = \mathbf{0} \Rightarrow x = \mathbf{0}), \quad (\text{B.1})$$

$$\forall (u, x, y) \in \mathbf{Q}^*(\mathbf{0}), \quad (y = \mathbf{0} \Rightarrow x \neq \mathbf{0}), \quad (\text{B.2})$$

where $\mathbf{Q}^*(\mathbf{0}) := \mathbf{Q}(\mathbf{0}) \setminus \{(\mathbf{0}, \mathbf{0}, \mathbf{0})\}$.

The first line of the table follows from the fact that (B.1) is equivalent to $\mathcal{R}^* = \{\mathbf{0}\}$ (see [8, Chap. 7]), so that $\nu = 0$ holds, by virtue of (16).

240 The second line of the table shows that $\rho = 0$ is equivalent to (B.2), if Σ is IR. Indeed, if $\rho > 0$ holds, then there exists a non-zero signal $u \in \text{Ker} \left\{ \begin{bmatrix} B \\ D \end{bmatrix} \right\}$ so that $(u, \mathbf{0}, \mathbf{0}) \in \mathbf{Q}(\mathbf{0})$ which contradicts (B.2). By contraposition, this proves that (B.2) implies $\rho = 0$. Conversely, assume that $\rho = 0$. By contradiction, assume that (B.2) does not hold, i.e. there exists a non-zero signal u such that $(u, \mathbf{0}, \mathbf{0}) \in \mathbf{Q}(\mathbf{0})$. This implies that $u \in \text{Ker} \{B\}$ and $y = Du = \mathbf{0}$. This contradicts the equality $\rho = 0$, so that (B.2) must hold.

245 Last line of the table follows immediately from the fact that IR of the third kind is equivalent to IR of neither the first nor the second kind.

Appendix C. Proof of Lem. 4.1

Define matrices Q and H as in Subsec. 4.1. Let F be a friend of \mathcal{V}^* . Then, it holds

$$\begin{bmatrix} -Q^{-1} & \mathbf{0} \\ \mathbf{0} & \mathbf{I} \end{bmatrix} P(s) \begin{bmatrix} Q & \mathbf{0} \\ FH & H \end{bmatrix} = \left[\begin{array}{cc|ccc} A_{11} - s\mathbf{I} & A_{12} & \mathbf{0} & B_{12} & B_{13} \\ \mathbf{0} & A_{22} - s\mathbf{I} & \mathbf{0} & \mathbf{0} & B_{23} \\ \hline \mathbf{0} & C_2 & \mathbf{0} & \mathbf{0} & D_3 \end{array} \right]. \quad (\text{C.1})$$

Recall that (A_{11}, B_{12}) is controllable so that $[A_{11} - s\mathbf{I}, B_{12}]$ is full rank, for all $s \in \mathbb{C}$. Together with (C.1), this proves that

$$\text{nrnk } P = \dim \mathcal{R}^* + \text{nrnk } P_3,$$

with

$$P_3(s) := \begin{bmatrix} A_{22} - s\mathbf{I} & B_{23} \\ C_2 & D_3 \end{bmatrix}.$$

Since quadruple $(A_{22}, B_{23}, C_2, D_3)$ is left-invertible by construction, the normal rank of P_3 equals the number of its columns, that is $n - \dim \mathcal{R}^* + m - \dim \mathcal{N}$. This proves (18).

250 Appendix D. Proof of Prop. 6.1

Subscripts a and p identify variables associated with Σ_a and Σ_p , respectively, e.g. x_a and x_p refer to state vector of those subsystems.

Define state $x(t)$ of Σ as $\begin{bmatrix} x_a^\top(t) & x_p^\top(t) \end{bmatrix}^\top$. Observe that

$$\begin{bmatrix} B \\ D \end{bmatrix} = \begin{bmatrix} \mathbf{I} & \mathbf{0} \\ \mathbf{0} & B_p \\ \mathbf{0} & D_p \end{bmatrix} \begin{bmatrix} B_a \\ D_a \end{bmatrix}.$$

The first matrix of this product is full rank since $\rho_p = 0$, due to left-invertibility of Σ_p . This implies (23).

By definition, \mathcal{R}^* gathers reachable states $\begin{bmatrix} x_a^{\star\top} & x_p^{\star\top} \end{bmatrix}^\top$ (from the origin) under the constraint $y = \mathbf{0}$, which
 255 is equivalent to $\tau = \mathbf{0}$ since Σ_p is left-invertible. This proves (24).

Together with Prop. 3.2 and (16), equalities (23) and (24) prove that Σ is input redundant of the k -th kind.

References

- [1] T. A. Johansen, T. I. Fossen, Control allocation—a survey, *Automatica* 49 (5) (2013) 1087–1103.
- 260 [2] J.-F. Tréguët, D. Arzelier, D. Peaucelle, C. Pittet, L. Zaccarian, Reaction wheels desaturation using magnetorquers and static input allocation, *Control Systems Technology, IEEE Transactions on* 23 (2) (2015) 525–539.
- [3] Y. Huang, C. K. Tse, Circuit theoretic classification of parallel connected dc-dc converters, *IEEE Transactions on Circuits and Systems I: Regular Papers* 54 (5) (2007) 1099–1108.
- 265 [4] L. Zaccarian, Dynamic allocation for input redundant control systems, *Automatica* 45 (6) (2009) 1431–1438.
- [5] A. Serrani, Output regulation for over-actuated linear systems via inverse model allocation, in: 51st IEEE Conference on Decision and Control, IEEE, 2012, pp. 4871–4876.

- [6] S. Galeani, A. Serrani, G. Varano, L. Zaccarian, On input allocation-based regulation for linear over-actuated systems, *Automatica* 52 (2015) 346–354.
- [7] M. W. Oppenheimer, D. B. Doman, M. A. Bolender, *Control allocation*, 2010, Ch. 8.
- [8] H. L. Trentelman, A. A. Stoorvogel, M. Hautus, *Control theory for linear systems*, Springer Science & Business Media, 2001.
- [9] L. Ntogramatzidis, D. Prattichizzo, Squaring down lti systems: A geometric approach, *Systems & control letters* 56 (3) (2007) 236–244.
- [10] S. Galeani, S. Pettinari, On dynamic input allocation for fat plants subject to multi-sinusoidal exogenous inputs, in: *53rd IEEE Conference on Decision and Control*, IEEE, 2014, pp. 2396–2403.
- [11] J. Kreiss, J.-F. Trégouët, R. Delpoux, J.-Y. Gauthier, X. Lin-Shi, A new framework for dealing with input constraints on parallel interconnection of buck converters, in: *18th European Control Conference*, IEEE, 2019, pp. 429–434.
- [12] J.-F. Trégouët, R. Delpoux, New framework for parallel interconnection of buck converters: Application to optimal current-sharing with constraints and unknown load, *Control Engineering Practice* 87 (2019) 59–75.