



HAL
open science

A renewable energy-aware power allocation for cloud data centers: A game theory approach

Mohammed Anis Benblidia, Bouziane Brik, Moez Esseghir, Leila Merghem-Boulahia

► To cite this version:

Mohammed Anis Benblidia, Bouziane Brik, Moez Esseghir, Leila Merghem-Boulahia. A renewable energy-aware power allocation for cloud data centers: A game theory approach. *Computer Communications*, 2021, 179, pp.102-111. 10.1016/j.comcom.2021.08.001 . hal-03357869

HAL Id: hal-03357869

<https://hal.science/hal-03357869>

Submitted on 22 Aug 2023

HAL is a multi-disciplinary open access archive for the deposit and dissemination of scientific research documents, whether they are published or not. The documents may come from teaching and research institutions in France or abroad, or from public or private research centers.

L'archive ouverte pluridisciplinaire **HAL**, est destinée au dépôt et à la diffusion de documents scientifiques de niveau recherche, publiés ou non, émanant des établissements d'enseignement et de recherche français ou étrangers, des laboratoires publics ou privés.



Distributed under a Creative Commons Attribution - NonCommercial 4.0 International License

A Renewable Energy-Aware Power Allocation For Cloud Data Centers: A Game Theory Approach

Mohammed Anis Benblidia^a, Bouziane Brik^b, Moez Esseghir^a and Leila Merghem-Boulahia^a

^aUniversity of Troyes, 10000 Troyes, France

^bDRIVE EA1859, Univ. Bourgogne Franche Comté, F58000, Nevers France

ARTICLE INFO

Keywords:

Cloud data centers
Green networking
Game theory
Renewable energy
Smart grid
Power dispatching

ABSTRACT

With the rapid emerging of Internet of Things (IoT) devices and the proliferation of cloud-based applications, the cloud computing industry is becoming a vital element for ensuring our daily services. However, cloud computing uses large scale data centers equipped with energy-hungry servers and huge power facilities that massively consume power. This presents a real challenge which can negatively influence the power grid, while exposing the environment to global warming issues. Therefore, minimizing cloud data center power consumption is a challenging problem and has to be addressed. In this paper, we look at renewable energy in the context of a smart grid-cloud architecture and investigate the issue of grid power dispatching to cloud data centers. Since cloud data centers have a non-cooperative nature regarding power demand from the power stations, we model our power allocation problem as a non-cooperative game. Afterwards, we prove the existence and the uniqueness of Nash equilibrium. Moreover, we formulate the payoff function of our game as a non-linear optimization problem before resolving it using Lagrange multipliers and KarushKuhn-Tucker (KKT) conditions. Thus, we determine the assigned optimal quantity to each data center based on three main criteria : renewable energy usage, number of critical running applications and workload charge. Extensive simulations are performed by comparing our scheme with an existing work. Results show that our scheme outperforms the comparing approach with a percentage of 31.2% in terms of power load rate and significantly reduces emissions of carbon dioxide.

1. Introduction

In today's world, everything is being digitized and connected to a network in order to communicate and interact with its environment. According to Cisco, 500 billion devices are expected to be connected to the Internet by 2030 [1]. This will generate a large amount of data that need to be processed by cloud applications. These services are carried out by computing, networking and storage resources of a large number of data centers. Therefore, cloud data centers are playing a vital role for ensuring a connected world but they tend to massively consume power from the grid. In fact, the data centers are expected to consume 8% of the worldwide power supply in the next five years [2] [3]. Also, they are responsible for 2% of total greenhouse gas emissions [4]. The smart grid is a modern intelligent power grid that allows bidirectional communications between the consumer and the utility company. This is done via a real time data transport in a communication infrastructure like: Powerline Communication (PLC), Cellular Network Communication, etc. [5] [6]. This feature allows the smart grid controller to have a complete view on its consumers' power behavior and to propose personalized and adapted solutions for its costumers. Moreover, smart grids allow integrating Distributed Energy Resources (DERs) [7], which can enhance the con-

sumer's energy efficiency and reduce gas emission.

The smart grid seems to be a relevant technology that could provide energy efficient solutions to cloud data centers [8] [9]. Based on [10] and [11] works, data centers compete for the most power from the smart grid, in order to store their energy and run as many users' applications as possible. This selfish behavior of data centers in demanding power does not consider the smart grid energy production capacity. Since smart grid is in charge of supplying multiple systems, this could lead to significant grid outages such as blackouts and loss of energy. Also, it can deprive a data center of having the sufficient amount of energy while satisfying the other data centers.

1.1. Main contributions

To overcome the above mentioned problems, we focus in this paper on the power management of cloud data centers from the smart grid's perspective. Unlike our previous work [12], that considers the smart grid as the only source of energy for the data centers, in this paper, we define a group of geographically scattered data centers that are powered by power grid as well as their own renewable energy. Our approach optimally dispatches power among the data centers according to their metrics. Our objective is to avoid power imbalance between the data centers and try to fairly allocate power between the data centers. To do so, we define five data centers' metrics based on: their workload charge, the number of their running critical applications, and their renewable energy usage. The major contributions in this paper are as follows:

- We considered renewable energy in a smart grid - cloud

This work is partially funded by grants from the University of Technology of Troyes and by the Grand-Est region research projects GREENCSG, SOLOTEC and FEDER.

*Corresponding author

 mohammed_anis.benblidia@utt.fr (M.A. Benblidia);

bouziane.brik@-bourgogne.fr (B. Brik); moez.esseghir@utt.fr (M.

Esseghir); leila.merghem_boulahia@utt.fr (L. Merghem-Boulahia)

ORCID(s):

architecture and use a non-cooperation game to model the allocation of power to cloud data centers.

- We demonstrated our game solution by proving the existence and uniqueness of Nash Equilibrium.
- We designed the payoff function of our game as a non-linear optimization problem and determined the optimal solution using KKT conditions.
- We compared our proposal with an existing power minimization approach, and found that our game scheme is more efficient in terms of power load rate with a percentage of 31.2% and significantly reduces carbon gas emission.

1.2. Organization

The rest of this paper is organized as follows. Next section gives a literature review of the related work. The system architecture and game formulation are detailed in Section 3. In Section 4, we demonstrate the existence and the uniqueness of Nash Equilibrium and calculate our game solution. Section 5 discusses the simulation results of our approach. Finally, Section 6 concludes this paper.

2. Related work and motivation

This section presents the related works and discusses our motivations to do this work. We present in section 2.1 a literature review of two categories of related works. In section 2.2, we present the strengths and weaknesses of the related work's schemes and detail the main contributions of our work regarding these works.

2.1. Literature review

Enhancing energy efficiency is one of the most difficult challenges in data centers. The huge power consumption problem of cloud data centers has been a subject of lot of research works. Different solutions have been proposed for greening cloud data centers. We can classify these works into two major categories detailed bellow. The first category tries to improve data centers' energy efficiency and proposes local solutions applied in IT data centers' infrastructure (servers, network equipments, etc.) while the second category considers a smart-grid cloud architecture and takes advantage of the features offered by the smart grid to improve power efficiency of cloud data centers.

2.1.1. Local based solutions

Since servers incur the biggest part of power consumption in a data center [19], managing data centers' servers for a better energy efficiency is the principal research topic of this first category of research works. Liu et al. [20] consider various sources of energy, and propose a power management architecture called DiPSN that efficiently connects different power sources to appropriate servers. Energy aware resources allocation and Virtual Machines (VMs) migration have been widely considered. Dai et al. [21] formulate the VM placement into servers in the data center as an integer

programming problem. They develop two approximation algorithms called MinES and MinCS to achieve the optimal solution that minimizes energy and guarantees the tenants' Service Level Agreements (SLA). Sharma et al. [22] propose an hybrid approach that combines a Genetic Algorithm (GA) and Particle Swarm Optimization (PSO) called HGAPSO that allows VM migration while reducing energy consumption and avoiding SLA violation. Thuan et al. [23] propose two Multi-level Joint VM placement and migration algorithms to minimize energy consumption in cloud data centers. They formulate the optimization problem as a joint multiple objective function and solve it by leveraging the framework of convex optimization.

2.1.2. Smart grid - Cloud based solutions

While the latter category considers a data center individually, the second category concentrates on the energy efficiency of inter data center networks and focuses on large-scale internet data centers with a diverse regional footprint, such as those owned and run by Amazon, Google, etc. The works of this category study the interaction of the smart grid with the cloud data centers and propose energy-saving solutions based on smart grid features [24]. Among the principle techniques used for this purpose, we note: (i) Demand Response (DR) and dynamic pricing mechanisms for reducing energy cost and (ii) incorporating renewable energy sources for energy optimization of geo distributed data centers. The general idea is to route user demands towards one or more data centers that can minimize electricity bills or gas emissions or maximize the utilization of renewable energy. Gu et al. [13] consider a smart-grid cloud system in which data centers are supplied by their own green energy and the power grid. They propose a request scheduler algorithm that minimizes cloud data centers' energy cost. This work has been extended in [10] by proposing a green scheduling algorithm for cloud data centers that reduces both energy costs and carbon emissions. In an another work, Wang et al. [14] consider the active decisions of both the cloud data centers and the smart grid in energy efficiency. First, they balance power load using dynamic pricing. After that, responding to energy prices, the cloud aggregator assigns the incoming workload to data centers in a way to minimize the total energy cost. Wang et al. [11] propose a renewable energy-aware demand response algorithm in order to minimize energy cost. Their proposal jointly optimizes energy supply and computing workload allocation in cloud data centers. Kiani et al. [15] try to maximize the profit associated with running geographically distributed green data centers. They consider in their system both renewable energy production, and electricity markets dynamic pricing. Ding et al. [16] develop a stochastic resource planning scheme to optimize the energy cost and carbon footprint in data centers. They consider the stochastic characteristics of renewable generation, electricity market price, and workload distribution. Markus et al. [17] investigate how data centres can benefit from variable energy prices in a smart grid environment. They propose two scheduling schemes for minimizing energy cost. The first one sim-

Table 1

A comparative study of some smart grid driven data centers energy efficiency works

Proposed Scheme	Price aware	Gas emission aware	Power load aware	Renewable aware
Gu et al [13]	X			X
Gu et al [10]	X	X		X
Wang et al [14]	X		X	
Wang et al [11]	X			X
Kiani et al [15]	X	X		X
Ding et al [16]	X	X		X
Markus et al [17]	X	X		X
Hu et al [18]	X		X	
Benblidia et al [12]	X		X	
This work	X	X	X	X

ply uses current smart meter values to dispatch the tasks, while the other one considers the future energy price in the grid based on weather forecasts. The two policies have a significant positive impact on the use of renewable energy and energy cost reduction. Hu et al. [18] consider a cost-efficient workload scheduling with a coordination between a cloud service provider operating geographically scattered data centers and smart grid. They investigate the flexibility of data center power demands in order to lower cloud service provider costs while also smoothing power load on smart grids.

2.2. Discussion

A comparison of the above-mentioned works, particularly those from the second category, is presented in Table 1. The comparison is based on considering four characteristics: price aware, gas emission aware, power load aware and renewable energy aware. We notice that the majority of the proposed schemes in a smart grid-cloud architecture are implemented on the cloud provider's end, and we can see that energy price and renewable energy are still two of the most important factors in improving cloud data centers' energy efficiency. However, few works have considered the role of the smart grid in managing power allocation to cloud data centers. Furthermore, the proposed schemes do not detail how they can impact the power grid, since they do not take into account the limited amount of energy that a smart grid controller can deliver.

As mentioned in Table 1, our previous work do not consider renewable energy in dispatching power among the data centers and do not investigate gas emissions problem.

In this paper, we consider a set of geographically dispersed data centers powered by both a smart grid controller and their self generated renewable energy. We optimally dispatch power among the data centers according to their metrics. Compared with our previous work, more real metrics are considered in this paper which globally consider renewable energy, data center's charge and the number of running applications. Our objective is to avoid power imbalance between the data centers and try to fairly allocate power between the data centers thus reducing power load on smart

grid and lowering dioxide carbon emissions.

We present in the following section more details about our architecture and system model.

3. System model

This section presents our system model and details our game scheme. Subsection 3.1 gives our system architecture and the problem formulation. Subsection 3.2 describes our game and details our payoff function formulation. We resume the principal parameters used in our system in the Table 2.

3.1. System architecture and problem formulation

As illustrated in Figure 1, we consider, in our system, a smart grid supplier that manages its consumers' energy supply. The smart grid controller is connected to power stations that provide power to geographically distributed data centers. The data centers are managed by different cloud providers that collect the incoming client's demands and assign them to their respective data centers. In order to perform their functions and execute their client requests, the data centers consume electricity from two sources: the main grid and their self generated renewable energy by wind turbines. We use wind turbines as the only renewable energy source due to their efficiency in terms of production of power rate and carbon emissions compared to solar panels [25] [26]. To handle wind power intermittency, the data centers are supplied with batteries to store energy.

In a smart grid architecture, a bi-directional communication is established between the utility company and its consumers. Hence, in our system, the data centers periodically exchange power informations with the smart grid utility via Power Line Communication. Therefore, the smart grid has a global vision on each data center's power behavior.

The smart grid supplies a set of geographically distributed data centers. We denote by d_k data center k ; $\forall k \in K$ with $K = \{1, 2, \dots, k, \dots, n\}$. We consider in our system a power assignment period of $T = \{1, \dots, t, \dots, \tau\}$ and we divide the daily horizon time into $\tau = 24$. We assume that each data

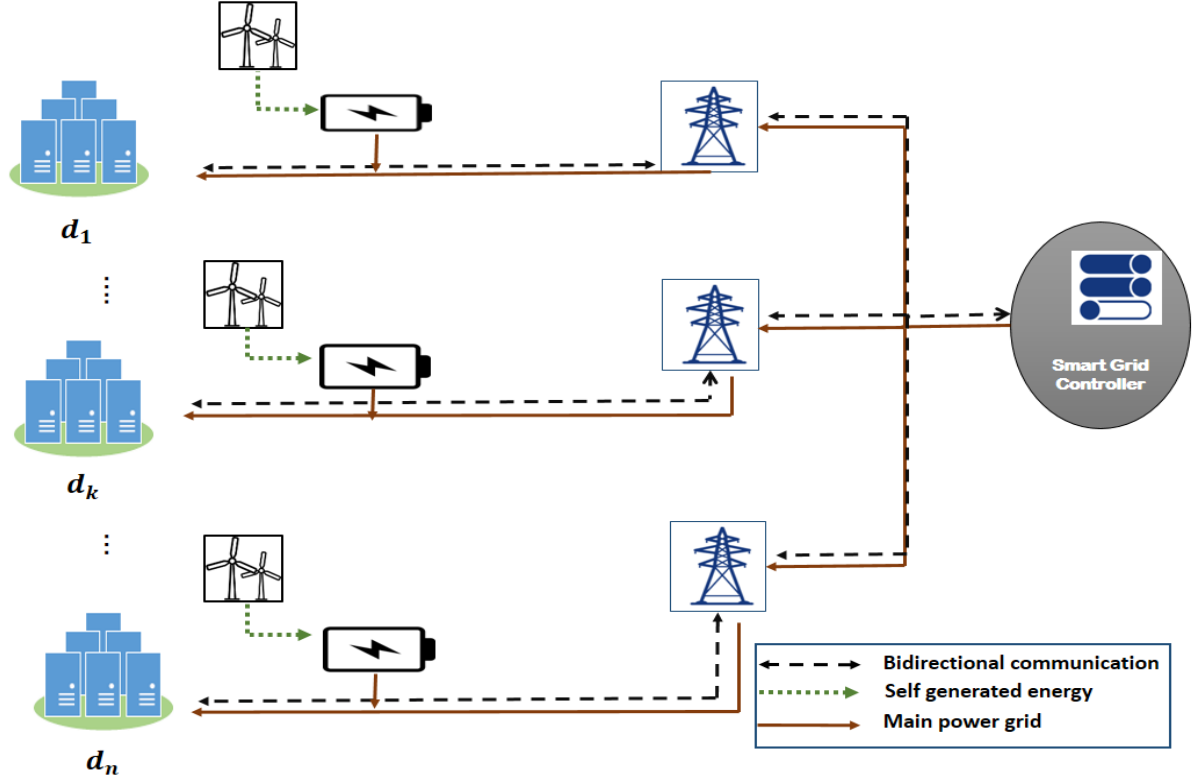

Figure 1: Our renewable energy-aware Smart Grid-Cloud architecture

center d_k , in each time slot $t \in T$, has a number of active servers s_k^t and a state of energy charge SEC_k^t stored on its battery. We assume that the grid can supply each data center d_k with a maximum quantity of power q_k^{max} . Also, each data center d_k has five metrics $DC_k^t, CA_k^t, TA_k^t, GEC_k^t$ and $REP_k^t \in [0, 1] \forall k \in K, \forall t \in T$ defined as follows [27]:

1. The data center's charge metric DC_k^t : reflects in each time slot $t \in T$ the metric of a data center in terms of its state of energy charge value SEC_k^t and its number of active servers s_k^t .
2. The critical applications metric CA_k^t : represents in each time slot $t \in T$ the ratio of the number of critical running applications in a data center, to its total running applications. We consider in our system real time applications as the critical applications.
3. The total critical applications metric TA_k^t : calculates for each data center the ratio of its number of critical running applications to the total critical applications running in all the data centers present in the system.
4. Green Energy coefficient metric GEC_k^t : reflects in each time slot $t \in T$ the green power consumption of a data center compared to its total power consumption.
5. Renewable Energy Production metric REP_k^t : compares the renewable energy production of a data center to the renewable energy production of all the data centers of the system.

In order to improve the benefits of their respective cloud providers, the data centers try to run as many client applications as possible. To do so, the data centers are competing to have the maximum of power from the smart grid without considering its power production capacity. This selfish behavior in demanding power may damage the power transmission lines or power distribution systems.

3.2. Game description and payoff function formulation

We use a non-cooperative game to model the data center's power allocation. We note the game: $G = (K, St_k, Gn_k)_{k \in K}$ with:

- K : is a set of data center players, $d_1, \dots, d_k, \dots, d_n$ where n is the number of the game players.
- $St_k; \forall k \in K$: Denotes the player d_k 's actions at any point during the game. In our context, the action reflects the amount of power required by a data center; we denote this quantity as q_k and its maximum value as q_k^{max} . Therefore, the required power quantity can vary between zero and q_k^{max} . So, $St_k = [0, q_k^{max}]$ and the strategy profile of all players is $St = \prod_{k=1}^n St_k = [0, q_1^{max}] \times \dots \times [0, q_k^{max}] \times \dots \times [0, q_n^{max}]$.
- $Gn_k : St_k \rightarrow \mathbb{R}$ represents the payoff function of player $d_k, \forall k \in K$. The goal of each player is to maximize its payoff function, $Gn_k, 0 \leq Gn_k \leq q_k^{max}, \forall k \in K$, for the purpose of increasing profits.

Table 2
Nomenclature

K	Set of data centers
T	Time horizon span
d_k	Data center k
q_k^{max}	Maximum power quantity that a data center can demand
q_k^t	Optimal power quantity assigned to a data center d_k
DC_k^t	Data center's charge metric
CA_k^t	Critical applications metric of a data center d_k
TA_k^t	Total applications metric of a data center d_k
GEC_k^t	Green Energy coefficient metric of a data center d_k
REP_k^t	Renewable Energy Production metric of a data center d_k
Gn_k	Game's payoff function
$\gamma_k(q_k^t)$	Utility function
$\theta_k(q_k^t, DC_k^t)$	Charge cost function
SEC_k^t	The stored energy state of a data center d_k
s_k^t	Number of active servers of a data center d_k
$\phi_k(q_k^t, CA_k^t)$	Critical applications cost function
rt_k^t	Real time applications running in a data center d_k
$apps_k^t$	Total running applications in a data center d_k
$\rho_k(q_k^t, TA_k^t)$	Total real time applications cost function
$\varphi_k(q_k^t, GEC_k^t)$	The cost function of green power usage
GC_k^t	The green power consumption of a data center d_k (renewable)
PC_k^t	The total power consumption of a data center d_k (renewable + non renewable)
PUE_k^t	Power Usage Effectiveness of d_k
C_{peak}	Server's peak power
C_{idle}	Server's idle power
ut_k^t	Servers' utilization
$\varrho_k(q_k^t, REP_k^t)$	Renewable energy production cost function
GP_k	Quantity of renewable energy produced by a data center d_k
$\alpha, \beta, \psi, \omega, \varpi, \vartheta$	Preferences coefficients
DEC_k	Dioxide carbon emission of a data center d_k
G_{ce}	Carbon emission rate of grid energy
W_{ce}	Carbon emission rate of wind energy

We aim to provide an equitable power allocation to data centers. Hence, in our system, the smart grid controller dispatches power according to the five, previously defined, data centers' metrics. Therefore, the payoff function is designed to include six functions: a function that calculates the high power quantity demands of the data centers (utility function), and a cost function for each data center's metric.

The six functions are defined as follows:

1. Utility function $\gamma_k(q_k^t)$: it is designed in such a manner

that the higher is the power quantity value of a data center, the greater is its profit. We choose to design this function with a commonly used utility function in network research studies [28], the logarithm function, which is strictly concave. Hence, we formulate the player d_k 's utility function as follows:

$$\gamma_k(q_k^t) = \log(q_k^t + 1), \forall k \in K, \forall t \in T \quad (1)$$

Where q_k^t is the quantity of power that a data center d_k demands in a time slot $t \in T$.

2. Charge cost function: is the cost that a data center must pay based on its demanding power quantity q_k^t and its DC_k^t metric. The latter goes high when a data center has low stored energy values and less active servers. This cost function is defined as follows :

$$\theta_k(q_k^t, DC_k^t) = q_k^t \times DC_k^t, \forall k \in K, \forall t \in T \quad (2)$$

Where

$$DC_k^t = 1 - \frac{1}{(C_{idle} * s_k^t) + SEC_k^t} \quad (3)$$

and C_{idle} is the idle power of a server in the data center.

3. Critical applications cost function: represents the cost that a data center must pay based on its demanding power quantity q_k^t and its critical application metric CA_k^t . We calculate this metric based on the ratio of the real time applications rt_k^t running on data center d_k to its total running applications $apps_k^t$. This function is defined as follows:

$$\phi_k(q_k^t, CA_k^t) = q_k^t \times CA_k^t, \forall k \in K, \forall t \in T \quad (4)$$

Where :

$$CA_k^t = 1 - \frac{rt_k^t}{apps_k^t} \quad (5)$$

4. Total applications cost function: involves the data center's demanding power quantity q_k^t and its TA_k^t metric. A data center has a lower cost when the number of its real time applications compared to the total number of real time applications of all the data centers goes high. We formulate this cost function as follows:

$$\rho_k(q_k^t, TA_k^t) = q_k^t \times TA_k^t, \forall k \in K, \forall t \in T \quad (6)$$

Where:

$$TA_k^t = 1 - \frac{rt_k^t}{\sum_{k=1}^n rt_k^t} \quad (7)$$

5. The cost function of green power usage: considers the data center's demanding power quantity q_k^t and its

GEC_k^t metric. This cost function promotes the data centers with high green power consumption. GEC_k^t calculates the data center's green energy coefficient GEC [29]. Thus, we define the function as follows:

$$\varphi_k(q_k^t, GEC_k^t) = q_k^t \times GEC_k^t \quad (8)$$

We formulate the green energy coefficient GEC to involve two data center's parameters. The first one is the green power consumption of a data center d_k denoted by GC_k^t and the second one is the total power consumption of a data center d_k denoted by PC_k^t . We formulate GEC_k^t as follows :

$$GEC_k^t = 1 - \frac{GC_k^t[kwh]}{PC_k^t[kwh]} \forall k \in K, \forall t \in T \quad (9)$$

Where

$$0 < GC_k^t \leq PC_k^t, \forall k \in K, \forall t \in T \quad (10)$$

We formulate the data center's total power consumption PC_k^t using the model presented in [13]:

$$PC_k^t = s_k^t [C_{idle} + (C_{peak} - C_{idle})ut_k^t] PUE_k^t \quad (11)$$

Where C_{peak} is the peak power of a data center's server and C_{idle} is its idle power. ut_k^t is the average data centers servers' utilization. PUE_k^t represents the Power Usage Effectiveness of a data center d_k in time slot t . (PUE) is the most popular data center metric regarding energy efficiency. It is the ratio of the total energy consumed by the data center to the energy consumed by its IT equipments [30].

6. The cost function of renewable energy production: considers the data center's demanding power quantity q_k^t and its renewable energy production metric REP_k^t . The metric REP_k^t is calculated as the quantity of renewable energy produced by a data center divided by the renewable energy produced by all the data centers. Thus, we have:

$$\rho_k(q_k^t, REP_k^t) = q_k^t \times REP_k^t \quad (12)$$

Where:

$$REP_k^t = \frac{GP_k}{\sum_{k=1}^n GP_k} \quad (13)$$

Since we consider that the data centers produce their renewable energy using wind turbines, we choose to estimate the wind energy production by using the Weibull distribution method. This method is one of the widely acceptable methods for estimating wind energy [31]. Hence, we model the renewable energy production of a data center as a Weibull random variable

GP_k with a probability density function [32]:

$$f_{GP_k}(GP_k; \lambda_1, \lambda_2) = \begin{cases} \frac{\lambda_2}{\lambda_1} \left(\frac{GP_k}{\lambda_1}\right)^{\lambda_2-1} e^{-(GP_k/\lambda_1)^{\lambda_2}} & ; GP_k \geq 0 \\ 0 & ; GP_k < 0 \end{cases} \quad (14)$$

Where $\lambda_1 > 0$ is the scale parameter and $\lambda_2 > 0$ is the shape parameter of the distribution.

Considering the above detailed functions, we give the payoff function of our game as follows:

$$Gn_k^t(q_k^t, q_{-k}^t) = \alpha \gamma_k(q_k^t) - \beta \theta_k(q_k^t, DC_k^t) - \psi \phi_k(q_k^t, CA_k^t) - \omega \rho_k(q_k^t, TA_k^t) - \varpi \varphi_k(q_k^t, GEC_k^t) - \vartheta \rho_k(q_k^t, REP_k^t) \quad (15)$$

Where:

- $q_{-k}^t = \{q_o^t\} (o \in K)$ and $k \neq o$ represents the strategies (quantity of power) of all the data centers expect the data center d_k .
- $st = (q_k^t, q_{-k}^t) \in St$ is the strategy profile.

The preference coefficients $\alpha, \beta, \psi, \omega, \varpi$ and ϑ are set by the smart grid controller to the functions $\gamma_k, \theta_k, \phi_k, \rho_k, \varphi_k$ and ρ_k , respectively, in order to satisfy its objective and requirements. The preference coefficients must be strictly greater than zero and their sum equal to 1.

After having detailed the different data center's metrics and formulated our game's payoff function, it is necessary to find and prove that our game has a solution. This is the subject of the next section.

4. Game solution

Before calculating our game solution, it is necessary to demonstrate that our non-cooperative game has a solution. Therefore, we prove in this section the existence of a Nash Equilibrium (NE), and demonstrate its uniqueness. After that, we detail our game solution.

4.1. Nash Equilibrium Existence

Nash Equilibrium (NE) is a principal concept in game theory. It determines the stable state of all players, where each player in the game has anything to gain in changing its strategy and continues to adopt the same action. Hence, a game has a solution if and only if a NE exists [33].

In our game model $G = (K, St_k, Gn_k)_{k \in K}$ a set of strategies $st^* = [q_1^*, \dots, q_k^*, \dots, q_n^*]$, $st^* \in St$ is a NE if no player in the game can have a better score when changing its strategy. Formally, NE is a K-tuple $\{q_k^*\}$ satisfying:

$$Gn_k(q_k^*, q_{-k}^*) \geq Gn_k(q_k, q_{-k}^*), \forall q_k^*, q_k \in St_k, q_k \neq q_k^* \forall k \in K \quad (16)$$

We use the following Nikaido-Isodra theorem [34] to demonstrate that it exists at least one NE: [Nikaiido-Isoda] The game $G = (K, St_k, Gn_k)_{k \in K}$ has at least one NE if and only if, $\forall k \in K$, St_k is compact and convex, and $Gn_k(q_k, q_{-k})$ is concave in St_k and continuous in the profile strategies $st \in St$.

- The strategy set for all players is $St = \prod_{k=1}^n St_k$, where $0 \leq St_k \leq q_k^{max}$, $\forall k \in K$. As $St_k = [0, q_k^{max}]$, the strategy set of each player is closed and bounded. Hence, the set St_k is compact, $\forall k \in K$.

Let $z_1, z_2 \in St_k$ be two points and $\epsilon = [0, 1]$. Therefore, we have $0 \leq \epsilon z_1 + (1 - \epsilon) z_2 \leq q_k^{max}$, which means that the point $\epsilon z_1 + (1 - \epsilon) z_2 \in St_k$. Thus, we can say that St_k is convex; $\forall k \in K$.

- To prove that the payoff function is concave, we calculate the Hessian matrix of $Gn(s)$, with $st = \{q_k\} \forall k \in K$, as follows:

$$H(st) = \begin{bmatrix} A_{11} & A_{12} & \cdots & A_{1n} \\ A_{21} & A_{22} & \cdots & A_{2n} \\ \vdots & \vdots & \ddots & \vdots \\ A_{n1} & A_{n2} & \cdots & A_{nn} \end{bmatrix} \quad (17)$$

Where $A_{kl} = \left(\frac{\partial^2 Gn_k}{\partial q_k \partial q_l} \right)$, $\forall k, l \in K$.

$$A_{kl} = \frac{\partial}{\partial q_l} \left[\frac{\partial Gn}{\partial q_k}(q_l, q_k) \right] = \frac{\partial}{\partial q_l} \left[\frac{\alpha}{(q_k+1)} - \beta DCp_k - \psi CAp_k - \omega TAp_k - \varpi GECp_k - \vartheta REPP_k \right]$$

Therefore, we obtain:

$$A_{kl} = \begin{cases} -\frac{\alpha}{(q_k+1)^2} < 0 & \text{if } k = l; \forall k, l \in K \\ 0 & \text{if } k \neq l; \forall k, l \in K \end{cases} \quad (18)$$

Regarding the leading principal minor of $H(st)$, we notice that for all strategies $st \in St$, $A(st)$ is negative definite, thus, $Gn_k(q_k, q_{-k})$ is strictly concave in St_k , $\forall k \in K$. Considering these conditions and based on Nikaido-Isodra theorem [34], it exists at least one NE in the game G .

4.2. Nash Equilibrium Uniqueness

We use Rosen's theorem [35] to prove the uniqueness of NE. Rosen's theorem states that if diagonally strict concavity is met, then the uniqueness is guaranteed. We note a random vector of positive parameters $v = (v_1, v_2, \dots, v_n)$ and define the weighted positive sum of the payoff function $Gn_k(q_k, q_{-k})$, $\forall k \in K$ as follows :

$$\zeta(q_k, q_{-k}; v) = \sum_{k=1}^n v_k Gn_k(q_k, q_{-k}), v_k \geq 0. \quad (19)$$

Where the pseudo-gradient of $\zeta(q_k, q_{-k}; v)$ is given by:

$$f(q_k, q_{-k}; v) = \begin{bmatrix} v_1 \nabla Gn_1(q_1, q_{-1}) \\ v_2 \nabla Gn_2(q_2, q_{-2}) \\ \vdots \\ v_n \nabla Gn_L(q_n, q_{-n}) \end{bmatrix} \quad (20)$$

We give:

$$\nabla Gn_k(q_k, q_{-k}) = \frac{\alpha}{(q_k+1)} - \beta \theta_k(q_k, DCp_k) - \psi \phi_k(q_k, CAp_k) - \omega \rho_k(q_k, TAp_k) - \varpi \varphi_k(q_k, GECp_k) - \vartheta \rho_k(q_k, REPP_k)$$

Also, we define the Jacobian matrix $JA(q_k, q_{-k}, v)$ of f as follows:

$$JA(q_k, q_{-k}, v) = \begin{bmatrix} C_{11} & C_{12} & \cdots & C_{1n} \\ C_{21} & C_{22} & \cdots & C_{2n} \\ \vdots & \vdots & \ddots & \vdots \\ C_{n1} & C_{n2} & \cdots & C_{nn} \end{bmatrix} \quad (21)$$

Where $C_{kl} = v_k A_{kl}$; $\forall k, l \in K$.

Therefore, we notice that the symmetric matrix $[JA + JA^T]$ is negative definite for all $q_k, q_{-k} \in St$. And according to Rosen's theorem [35], the function $\zeta(q_k, q_{-k}; v)$ is diagonally strictly concave. Hence, the game G has a unique NE.

4.3. Optimal solution

To calculate our optimal solution, we model a constrained non linear optimization problem. We use Lagrange multipliers method to resolve the problem.

Each data center in our game tries to maximize its profit by maximizing its power demands. Hence, we model our problem (F') as follows:

$$\begin{aligned} & \text{Maximize}_{q_k^t} && Gn_k^t(q_k^t, q_{-k}^t) \\ & \text{subject to} && q_k^t \geq 0, \\ & && q_k^t - q_k^{max} \leq 0, \forall k \in K. \end{aligned}$$

To solve the problem (F'), we use two Lagrange multipliers ℓ_k and ℓ'_k . We give the Lagrange function as follows:

$$M_k(q_k^t, \ell_k, \ell'_k) = Gn_k^t(q_k^t, q_{-k}^t) + \ell_k q_k^t + \ell'_k (q_k^{max} - q_k^t) \quad (22)$$

Therefore, the defined Lagrange function satisfies the following KKT conditions for each player d_k :

$$\begin{aligned} & \ell_k, \ell'_k \geq 0 \\ & q_k^t \geq 0 \\ & q_k^{max} - q_k^t \geq 0 \\ & \nabla_{q_k^t} Gn_k^t(q_k^t, q_{-k}^t) + \ell_k \nabla_{q_k^t} q_k^t + \ell'_k \nabla_{q_k^t} (q_k^{max} - q_k^t) = 0 \\ & \ell_k q_k^t + \ell'_k (q_k^{max} - q_k^t) = 0 \end{aligned} \quad (23)$$

After resolution, we determine the optimal power demand (q_k^{t*}) for data center d_k , $\forall k \in K$, as follows:

$$q_k^{t*} = \begin{cases} 0 & \text{if cdt 1} \\ q_k^{max} & \text{if cdt 2} \\ \frac{\alpha}{\beta \theta_k(q_k^t, DC_k^t) + \psi \phi_k(q_k^t, CA_k^t) + \omega \rho_k(q_k^t, TA_k^t) + \varpi \varphi_k(q_k^t, GEC_k^t) + \vartheta \rho_k(q_k^t, REPP_k^t)} - 1 & \text{otherwise} \end{cases}$$

(24)

Where cdt 1 and 2, respectively, are:

$$\beta\theta_k(q_k^t, DC_k^t) + \psi\phi_k(q_k^t, CA_k^t) + \omega\rho_k(q_k^t, TA_k^t) + \varpi\varphi_k(q_k^t, GEC_k^t) + \vartheta\varrho_k(q_k^t, REP_k^t) \geq \alpha \quad (25)$$

$$\beta\theta_k(q_k^t, DC_k^t) + \psi\phi_k(q_k^t, CA_k^t) + \omega\rho_k(q_k^t, TA_k^t) + \varpi\varphi_k(q_k^t, GEC_k^t) + \vartheta\varrho_k(q_k^t, REP_k^t) \leq \frac{\alpha}{q_k^{max+1}} \quad (26)$$

After determining the optimal solution, we exploit this result to show the efficiency of our scheme in the following section.

5. Simulation and Experimental Results

This section presents our simulation results and studies the performance of our scheme compared with an existing work.

5.1. Simulation Setup and Parameters

We consider three geographically dispersed data centers that purchase from the smart grid a maximum power of $q_k^{max} = 10 MWh$. In addition, each data center uses its own wind turbines to produce renewable energy. Each data center has the same number of 400NE-3000 wind turbines which are geographically distributed in regions with different climates. We use function (14) to simulate the wind energy production. Also, each data center is equipped with 6000 homogeneous servers. We run our simulation over 24 hours, and measure the data center's power demand every 2 hours in two separate periods: on-peak times (from 6 am to 10 pm) and off-peak times (from 10 pm to 6 am). We note that the coefficient values of the payoff function are set by the smart grid controller according to its requirements. We set $\alpha = 0.5$ in order to incentive the data centers to highly purchase power from the grid, also because the sum of the penalties ($\beta, \psi, \omega, \varpi$ and ϑ) is equal to 0.5.

The simulations were performed using Matlab on a *Dell OptiPlex 7050* (Intel Core i7 CPU 2.90GHz with 32G RAM). Determining the optimal solution has allowed us to execute our program in 0.94 seconds with 100 iterations. Parameter setting of our simulation are detailed in Table 3.

We have to note that we are not allowed to share our source code in a public repository for confidential reasons.

To evaluate our approach, we compare it with two approaches:

- **Renewable Energy Based (REB)** scheme: an existing approach presented in [11]. The authors of this work consider renewable energy in order to minimize cloud data centers' energy cost by optimizing grid power consumption. They tackle the data centers' energy management problem from the cloud provider's perspective and try to assign client requests to the data

Table 3

Simulation parameters

Parameters	Values
q_k^{max}	10 MWh
Number of data centers (n)	3
s_k^t	[1 – 6000]
Servers' utilization (ut_k^t)	[2.2 – 3]
C_{idle}	[70 – 100] MW
C_{peak}	[200 – 300] MW
$PU E_k^t$	[1.1 – 2]
$\alpha, \beta, \psi, \omega, \varpi, \vartheta$	(0.5, 0.1, 0.1, 0.1, 0.1, 0.1)
On-peak times	[6am – 10pm]
Off-peak times	[10pm – 6am]
Wind energy CER	22.5 (gCO_2e/kwh)
Grid energy CER	968 (gCO_2e/kwh)

center with a sufficient renewable wind energy.

- **Price based approach:** we suppose that this scheme tries to assign power according to the grid energy price. So, we suppose that it allocates 90% of grid power at off-peak times and 70% at on-peak times. The rest of the needed power is supplied by green energy.

In our simulations, we globally set the same parameters used in [11] (number of servers s_k^t , servers' utilization (ut_k^t), C_{peak} and C_{idle}) and consider the same renewable energy supply in each data center. The availability of the wind generated energy on each data center over a day (24 hours) is depicted in Figure 2.

5.2. Data centers game results

Figure 3 gives for each data center the varying costs of their respective metrics during one day. We observe in Figure 3-a that the data center's charge (DC) cost of the three data centers is low during off-peak hours when the data center do not have many active servers and stored energy, and high during on-peak hours when they have charged their energy and have a high number of active servers. In our simulation, we set much more real time applications during on-peak hours (with an average of 29%) compared to the number of applications running during off-peak hours, according to smart systems workloads during the day like Smart Homes, Industry 4.0, Autonomous vehicles, etc. Hence, the varying costs of CA depicted in Figure 3-b are higher during off-peak hours than they are during on-peak hours. In addition, we can observe that the costs of TA in Figure 3-c vary correctly depending on the number of real time applications of each data center compared to the total number of real time applications running in all the data centers. Furthermore, we see in Figure 3-d that the costs of the REP metric of the three data centers are varying according to their wind energy production depicted in Figure 2. Moreover, we model our scheme in a way that the data center promotes the use of the grid energy with a low price during off-peak hours and stores the wind energy for a later use during on-peak hours

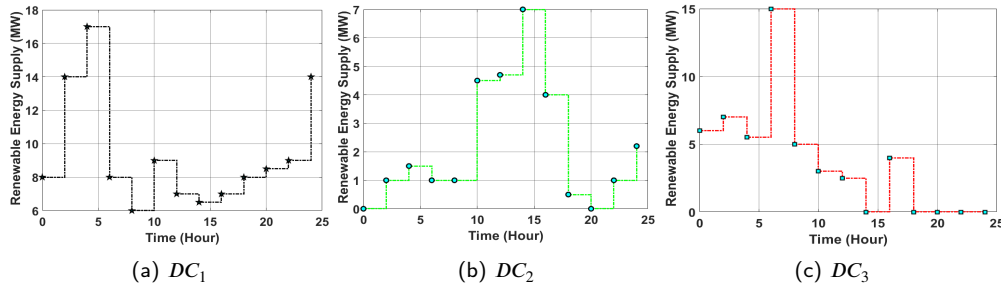

Figure 2: Data centers' renewable energy production

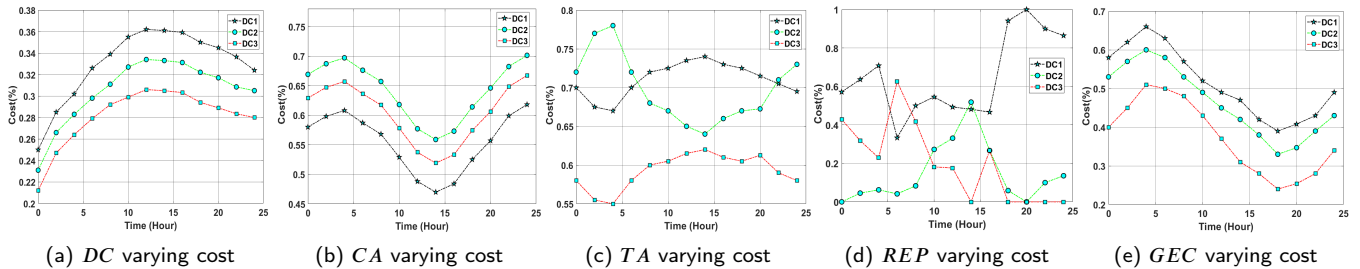

Figure 3: Data centers' varying costs

when the grid energy price is high. We can verify this in Figure 3-e where the costs of the *GEC* in each data center are high during off-peak hours and low during on-peak hours.

Figure 4 gives the power that has been assigned for each data center during 24 hours using our non-cooperative game approach, price based scheme and *REB* scheme [11]. We can see that the price based approach allocates power in cloud

data centers with a constant quantity at off-peak times and a lower constant quantity at on-peak times. It reduces the power allocated to data centers, but it does not consider the data centers priorities, and may deprive other data centers that need more power than others. On the other hand, we observe that the quantity of power allocated to data centers using the *REB* scheme is low during off-peak hours and high during peak hours. This corresponds to their renew-

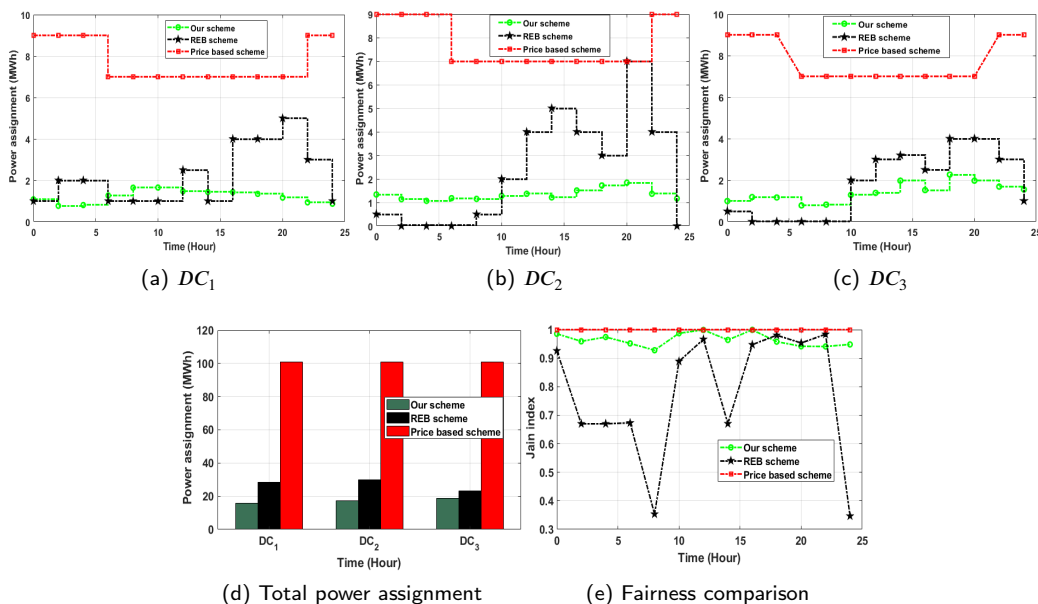

Figure 4: Performance of our game approach compared to *REB* scheme and price based scheme

able energy supply depicted in Figure 2, where they have a high renewable energy supply during off-peak hours and a low renewable energy supply during on-peak hours. Similar to the *REB* approach, the power allocated using our game scheme is low during off-peak hours and high during on-peak hours, however, our approach allows to have a balance between the use of grid and renewable energy. In fact, our scheme penalizes the data centers for having more power when they have a high *REP* value and a low *GEC* value. This means that our proposal incites the data centers to be more efficient in terms of green energy usage and to consume more renewable energy in parallel with the grid energy. To better show the performance of our approach, we give in Figure 4-d the total power assigned for each data center during one day. We can remark that the power assigned using our scheme is less than the power assigned using *REB* approach and price based approach. This is due to our non-cooperative game scheme where the smart grid controller fairly dispatches power among the data centers by penalizing the data centers according to their different metrics, in contrary to *REB* scheme which considers only the data centers' renewable energy supply.

To better show the fairness of our proposal, we depict in Figure 4-e the Jain's fairness index of our game scheme comparing it to *REB* scheme and price based scheme.

Jain's fairness index is the measure of fairness among the active flows (which are the data centers in our case) in a network. The index ranges between $\frac{1}{n}$ and 1, representing *worst* and *best* fairness respectively [36]. We calculate the Jain's fairness index using the following function [37]:

$$Jain(Y) = \frac{[\sum_{k=1}^n Y_k]^2}{\sum_{i=1}^m Y_i^2} \quad (27)$$

Where

$$Y_k = \frac{q_k^{max}}{q_k} \quad (28)$$

We have to note that the allocation tends to be fairer when Jain's index is closer to 1, and we can see in Figure 4-e that our scheme allows a fair allocation comparing to *REB* scheme. Obviously, the price based scheme has a better result, because it dispatches constantly and equally a higher quantity of power among all the data centers.

5.3. Power load rate and Carbon Emission Performance

In this subsection, we consider two metrics to evaluate our game scheme: carbon emission, and power load rate. The power load rate is the proportion of the total power assigned by the main grid to the maximum amount of power that can be allocated in a single day. The carbon emission metric measures the emitted quantity of *Co2* by each data center in a single day. We give the following function to calculate the dioxide carbon emission DCE_k of each data

center:

$$DEC_k = \sum_{t=1}^T (q_k^t * G_{ce}) + ((q_k^{max} - x_k^t) * W_{ce}) \quad (29)$$

Where G_{ce} and W_{ce} are respectively the carbon emission rate *CER* [25] of grid and wind energy. We present in Figure 5-a the power load rate of each data center using our non-cooperative game, price based scheme and the *REB* scheme. We notice that, at each data center, our proposal has less power load rate than the *REB* scheme and price based scheme. Indeed, our game scheme outperforms *REB* with a percentage of 31.2% and price based scheme with a percentage of 72%.

The effectiveness of our proposal in terms of gas emissions is shown in Figure 5-b. We can see that our approach outperforms *REB* approach and price based scheme and substantially lowers carbon dioxide emissions. This can be explained by the fact that our game balances the use of grid and renewable energy by promoting the use of renewable energy while fairly dispatching grid power among the data centers.

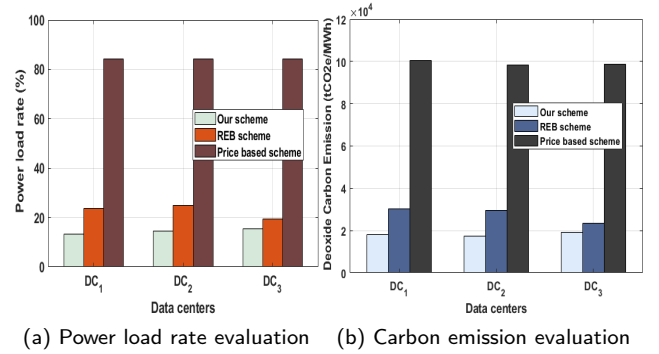

Figure 5: Performance of our game in terms of carbon emissions and power load rate

6. CONCLUSION

In this paper, we consider renewable energy for power allocation in cloud data centers. We formulate the main grid power dispatching to cloud data centers as a non-cooperative game, then we calculate the optimal quantity of power to be delivered to each data center. Experimental results showed that our game approach assigns power to data centers in a fair way according to their different metrics. In order to validate our proposal, we compared it with an existing power minimization approach, and found that our game scheme is more effective in terms of power load rate with a percentage of 31.2% and greatly reduces carbon dioxide emissions. In addition, we prove the fairness of our power allocation scheme using Jain's fairness index.

This work can be improved by considering the security side of our data centers agents for communicating biased parameters.

Furthermore, for future work, we aim at considering dynamic

pricing in a smart grid - cloud architecture. We intend to deal with client requests dispatching issue by minimizing energy cost of cloud data centers while considering the client security requirements.

References

- [1] Internet of things at a glance - cisco, 2016. <https://www.cisco.com/c/en/us/products/collateral/se/internet-of-things/at-a-glance-c45-731471.pdf> Accessed 06/05/2021.
- [2] N. H. Tran, D. H. Tran, S. Ren, Z. Han, E. Huh, C. S. Hong, How geo-distributed data centers do demand response: A game-theoretic approach, *IEEE Transactions on Smart Grid* 7 (2016) 937–947. doi:10.1109/TSG.2015.2421286.
- [3] M. A. Benblidia, B. Brik, L. Merghem-Boulahia, M. Esseghir, Ranking fog nodes for tasks scheduling in fog-cloud environments: A fuzzy logic approach, in: 2019 15th International Wireless Communications Mobile Computing Conference (IWCMC), 2019, pp. 1451–1457. doi:10.1109/IWCMC.2019.8766437.
- [4] Tsunami of data' could consume one fifth of global electricity by 2025, 2017. <https://www.climatechangenews.com/2017/12/11/tsunami-data-consume-one-fifth-global-electricity-2025> Accessed 06/05/2021.
- [5] V. C. Gungor, D. Sahin, T. Kocak, S. Ergut, C. Buccella, C. Cecati, G. P. Hancke, Smart grid technologies: Communication technologies and standards, *IEEE Transactions on Industrial Informatics* 7 (2011) 529–539. doi:10.1109/TII.2011.2166794.
- [6] M. A. Benblidia, B. Brik, M. Esseghir, L. Merghem-Boulahia, Power dispatching in cloud data centers using smart microgrids: A game theory approach, in: 2019 IEEE Global Communications Conference (GLOBECOM), 2019, pp. 1–6. doi:10.1109/GLOBECOM38437.2019.9013640.
- [7] S. Bera, S. Misra, J. J. P. C. Rodrigues, Cloud computing applications for smart grid: A survey, *IEEE Transactions on Parallel and Distributed Systems* 26 (2015) 1477–1494. doi:10.1109/TPDS.2014.2321378.
- [8] B. Brik, N. Lagraa, A. Lakas, Y. Ghamri-Doudane, Rcs-vc: renting out and consuming services in vehicular clouds based on lte-a, in: 2015 Global Information Infrastructure and Networking Symposium (GIIS), 2015, pp. 1–6. doi:10.1109/GIIS.2015.7347174.
- [9] B. Brik, N. Lagraa, N. Tamani, A. Lakas, Y. Ghamri-Doudane, Renting out cloud services in mobile vehicular cloud, *IEEE Transactions on Vehicular Technology* 67 (2018) 9882–9895. doi:10.1109/TVT.2018.2858002.
- [10] C. Gu, L. Fan, W. Wu, H. Huang, X. Jia, Greening cloud data centers in an economical way by energy trading with power grid, *Future Generation Computer Systems* 78 (2018) 89 – 101. URL: <http://www.sciencedirect.com/science/article/pii/S0167739X16308330>. doi:https://doi.org/10.1016/j.future.2016.12.029.
- [11] H. Wang, Z. Ye, Renewable energy-aware demand response for distributed data centers in smart grid, in: 2016 IEEE Green Energy and Systems Conference (IGSEC), 2016, pp. 1–8. doi:10.1109/IGESC.2016.7790076.
- [12] M. A. Benblidia, B. Brik, M. Esseghir, L. Merghem-Boulahia, A game based power allocation in cloud computing data centers, in: 2018 14th International Conference on Wireless and Mobile Computing, Networking and Communications (WiMob), 2018, pp. 1–7. doi:10.1109/WiMOB.2018.8589177.
- [13] C. Gu, K. Hu, Z. Li, Q. Yuan, H. Huang, X. Jia, Lowering down the cost for green cloud data centers by using esds and energy trading (2016) 1508–1515. doi:10.1109/TrustCom.2016.0235.
- [14] H. Wang, J. Huang, X. Lin, H. Mohsenian-Rad, Proactive demand response for data centers: A win-win solution, *IEEE Transactions on Smart Grid* 7 (2016) 1584–1596. doi:10.1109/TSG.2015.2501808.
- [15] A. Kiani, N. Ansari, Profit maximization for geographically dispersed green data centers, *IEEE Transactions on Smart Grid* 9 (2018) 703–711. doi:10.1109/TSG.2016.2562565.
- [16] Z. Ding, L. Xie, Y. Lu, P. Wang, S. Xia, Emission-aware stochastic resource planning scheme for data center microgrid considering batch workload scheduling and risk management, *IEEE Transactions on Industry Applications* 54 (2018) 5599–5608. doi:10.1109/TIA.2018.2851516.
- [17] M. Mäsker, L. Nagel, A. Brinkmann, F. Lotffar, M. Johnson, Smart grid-aware scheduling in data centres, *Computer Communications* 96 (2016) 73–85. URL: <https://www.sciencedirect.com/science/article/pii/S0140366416301608>. doi:https://doi.org/10.1016/j.comcom.2016.04.021.
- [18] H. Hu, Y. Wen, L. Yin, L. Qiu, D. Niyato, Coordinating workload scheduling of geo-distributed data centers and electricity generation of smart grid, *IEEE Transactions on Services Computing* 13 (2020) 1007–1020. doi:10.1109/TSC.2017.2773617.
- [19] D. Kliazovich, P. Bouvry, Y. Audzevich, S. U. Khan, Greencloud: A packet-level simulator of energy-aware cloud computing data centers, in: 2010 IEEE Global Telecommunications Conference GLOBECOM 2010, 2010, pp. 1–5. doi:10.1109/GLOCOM.2010.5683561.
- [20] L. Liu, H. Sun, C. Li, Y. Hu, T. Li, N. Zheng, Exploring customizable heterogeneous power distribution and management for datacenter, *IEEE Transactions on Parallel and Distributed Systems* 29 (2018) 2798–2813. doi:10.1109/TPDS.2018.2841405.
- [21] X. Dai, J. M. Wang, B. Bensaou, Energy-efficient virtual machines scheduling in multi-tenant data centers, *IEEE Transactions on Cloud Computing* 4 (2016) 210–221. doi:10.1109/TCC.2015.2481401.
- [22] N. K. Sharma, G. R. M. Reddy, Multi-objective energy efficient virtual machines allocation at the cloud data center, *IEEE Transactions on Services Computing* 12 (2019) 158–171. doi:10.1109/TSC.2016.2596289.
- [23] T. H. Duong-Ba, T. Nguyen, B. Bose, T. T. Tran, A dynamic virtual machine placement and migration scheme for data centers, *IEEE Transactions on Services Computing* (2018) 1–1. doi:10.1109/TSC.2018.2817208.
- [24] N. Tamani, B. Brik, N. Lagraa, Y. Ghamri-Doudane, On link stability metric and fuzzy quantification for service selection in mobile vehicular cloud, *IEEE Transactions on Intelligent Transportation Systems* 21 (2020) 2050–2062. doi:10.1109/TITS.2019.2911860.
- [25] Wind vs solar - which power source is better ?, 2016. <https://elemental.green/wind-vs-solar-which-power-source-is-better/> Accessed 06/05/2021.
- [26] P. X. Gao, A. R. Curtis, B. Wong, S. Keshav, It's not easy being green (2012) 211–222. URL: <http://doi.acm.org/10.1145/2342356.2342398>. doi:10.1145/2342356.2342398.
- [27] D. A. Kez, A. M. Foley, S. M. Mueyen, D. J. Morrow, Manipulation of static and dynamic data center power responses to support grid operations, *IEEE Access* 8 (2020) 182078–182091. doi:10.1109/ACCESS.2020.3028548.
- [28] L. Wang, G. S. G. S. Kuo, Mathematical modeling for network selection in heterogeneous wireless networks x2014; a tutorial, *IEEE Communications Surveys Tutorials* 15 (2013) 271–292.
- [29] The organisation for economic co-operation and development (oecd), nomura research institute (nri) presentation., 2010. <http://www.oecd.org/sti/ind/45009540.pdf> Accessed 06/05/2021.
- [30] M. Erol-Kantarci, H. T. Mouftah, Energy-efficient information and communication infrastructures in the smart grid: A survey on interactions and open issues, *IEEE Communications Surveys Tutorials* 17 (2015) 179–197. doi:10.1109/COMST.2014.2341600.
- [31] S. Walia, K. S. Sandhu, Capacity factor of wind turbine system based on different power curves and weibull distribution parameters, in: 2019 3rd International Conference on Computing Methodologies and Communication (ICCMC), 2019, pp. 1135–1138. doi:10.1109/ICCMC.2019.8819668.
- [32] A. Azad, M. Rasul, R. Islam, I. R. Shishir, Analysis of wind energy prospect for power generation by three weibull distribution methods, *Energy Procedia* 75 (2015) 722 – 727. URL: <http://www.sciencedirect.com/science/article/pii/S1876610215012679>. doi:https://doi.org/10.1016/j.egypro.2015.07.499, clean, Efficient and Affordable Energy for a Sustainable Future: The 7th International

- Conference on Applied Energy (ICAE2015).
- [33] J. F. Nash, Equilibrium points in n-person games, Proceedings of the National Academy of Sciences 36 (1950) 48–49. URL: <https://www.pnas.org/content/36/1/48>. doi:10.1073/pnas.36.1.48. arXiv:<https://www.pnas.org/content/36/1/48.full.pdf>.
- [34] H. Nikaidō, K. Isoda, Note on non-cooperative convex games, Pacific J. Math. 5 (1955) 807–815.
- [35] J. B. Rosen, Existence and Uniqueness of Equilibrium Points for Concave N-Person Games, Econometrica 33 (1965) 520–534.
- [36] H. Zafar, Z. H. Abbas, G. Abbas, F. Muhammad, M. Tufail, S. Kim, An effective fairness scheme for named data networking, Electronics 9 (2020) 749.
- [37] H. SHI, R. V. Prasad, E. Onur, I. G. M. M. Niemegeers, Fairness in wireless networks: issues, measures and challenges, IEEE Communications Surveys Tutorials 16 (2014) 5–24. doi:10.1109/SURV.2013.050113.00015.



Mohammed Anis Benblidia Received the B.S degree in computer science from the University of Science and Technology Houari Boumediene, Algiers, Algeria, in 2013 and the master's degree in information systems security from the University of Technology of Troyes, France, in 2017. He is currently pursuing the Ph.D. degree in the Environment and Autonomous Networks Laboratory, University of Technology of Troyes. His research area focuses on resource allocation in Fog-cloud architecture, smart grid energy management and energy efficiency in cloud data centers.



Bouziane BRIK received engineering degree in computer science, ranked first in his class, and the Magister degree from the University of Laghouat, Algeria, in 2010 and 2013, respectively, and the Ph.D. degree from Laghouat and La Rochelle (France) universities, in 2017. He is currently working as associate professor at Burgundy (Bourgogne) university and DRIVE laboratory. Before joining Burgundy university, he was a post-doc at university of Troyes, CESI school, and Eurecom school. He has been working on network slicing in the context of H2020 European projects on 5G including MonB5G and 5GDrones. His research interests also include the Internet of Things (IoT), the IoT in industrial systems, smart grid, and vehicular networks. He also acted or still acts as a Reviewer of many IFIP, ACM, and IEEE conferences (ICC, Globecom, PIMRC, WCNC, VTC, IM/NOMS, IWCMC, GIIIS, WiMob, and Wireless Days) and journals such as the IEEE TRANSACTIONS ON VEHICULAR TECHNOLOGY, the IEEE TRANSACTIONS ON INTELLIGENT TRANSPORTATION SYSTEMS (ITS), the IEEE TRANSACTIONS ON INDUSTRIAL INFORMATICS, the IEEE Communication Magazine, and the IEEE Network Magazine.



Moez ESSEGHIR received the National Engineer Diploma degree in computer sciences from the Ecole Nationale des Sciences Informatique (ENSI), Tunis, Tunisia, in 2002, the Master of Science degree in networks from the University of Paris 6, Paris, France, in 2003, the M.S. degree in computer sciences from ENSI in 2004, and the Ph.D. degree in computer sciences from the University of Paris 6 in 2007. In 2008, he was with

North Carolina State University, Raleigh, USA, as a Visiting Scholar. Since 2008, he has been an Associate Professor with the University of Technology of Troyes, France, and the Leader of ERA Research Team since 2017. He has authored or coauthored over 40 publications, including international journals and conferences. His research interests include energy management, resource allocation, and performance evaluation in different kind of networks, such as HetNets, WSN, CRN, VANET, smart grids, cloud environment, and Internet of Things. He actively participated in numerous projects and has served as a technical program committee member and a reviewer for well-known international conferences and journals. He is a member of ACM and IEEE Computer Society.



Pr. Leila Merghem-Boulahia received an engineering degree in computer science from the University of Setif, Algeria, in 1998, an M.S. degree in artificial intelligence and a Ph.D. in computer science from the University of Paris 6, France, in 2000 and 2003, respectively. She received the "Habilitation a diriger des recherches" degree in Computer Science from the University of Compiègne in 2010. She is a full professor at the University of Technology of Troyes (UTT) in France and the head of ISIFT (Troyes Institute of services and industry of future). Her main research topics include multi-agent systems, quality of service management, autonomic networks, cognitive and sensor networks, smart grids and IoT. Pr. Merghem-Boulahia authored or co-authored more than 100 international journals and conference papers. She received the best paper award of the IFIP WMNC'2009 and GIIIS'2013. She also acted as a TPC member of many conferences and workshops (IEEE Globecom, IEEE ICC, IEEE WCNC...) and has served as a reviewer for internationally well-known journals (IEEE Communications letters, IEEE Transactions on Industrial Informatics Review, Communication Networks, Computer and Communication Networks, International Journal of Network Management...). She is IEEE member.