



**HAL**  
open science

## On the Capacity Region of Gaussian Broadcast Channels under Two-Sided Noisy Feedback

Aditya Narayan Ravi, Sibi Raj B. Pillai, Vinod M Prabhakaran, Michèle Wigger

► **To cite this version:**

Aditya Narayan Ravi, Sibi Raj B. Pillai, Vinod M Prabhakaran, Michèle Wigger. On the Capacity Region of Gaussian Broadcast Channels under Two-Sided Noisy Feedback. 2021 IEEE International Symposium on Information Theory (ISIT), Jul 2021, Melbourne, Australia. pp.2870-2875, 10.1109/ISIT45174.2021.9518098 . hal-03349700

**HAL Id: hal-03349700**

**<https://hal.science/hal-03349700>**

Submitted on 20 Sep 2021

**HAL** is a multi-disciplinary open access archive for the deposit and dissemination of scientific research documents, whether they are published or not. The documents may come from teaching and research institutions in France or abroad, or from public or private research centers.

L'archive ouverte pluridisciplinaire **HAL**, est destinée au dépôt et à la diffusion de documents scientifiques de niveau recherche, publiés ou non, émanant des établissements d'enseignement et de recherche français ou étrangers, des laboratoires publics ou privés.

# On the Capacity Region of Gaussian Broadcast Channels under Two-Sided Noisy Feedback

Aditya Narayan Ravi\*, Sibi Raj B. Pillai<sup>†</sup>, Vinod M. Prabhakaran<sup>‡</sup> and Michèle Wigger<sup>§</sup>

\*University of Illinois, Urbana-Champaign, anravi2@illinois.edu

<sup>†</sup>Dept. of Electrical Engineering, Indian Institute of Technology Bombay, bsraj@ee.iitb.ac.in

<sup>‡</sup>School of Tech. and Computer Science, Tata Institute of Fundamental Research, Mumbai, vinodmp@tifr.res.in

<sup>§</sup>LTCI Telecom Paris, IP Paris, France, michele.wigger@telecom-paris.fr

**Abstract**—The capacity region of several multiuser models in information theory can be enlarged by utilizing feedback of the received symbols. This is in contradiction to the discrete memoryless case, where feedback is known not to change the capacity. In this paper, we consider two broadcast models with noisy feedback from both the receivers. The models are derived from a standard memoryless scalar GBC, where two intermediate passive nodes are assumed to be observing the transmissions via separate noisy links corrupted by independent AWGN. In our first model, the scalar output from each intermediate node is passed through two additional independent AWGN links, called feedback and forward links. The output of the feedback link is observed by the transmitter as feedback, whereas only the forward link is observed by the corresponding decoder. We derive conditions that are both necessary and sufficient for feedback to enlarge the capacity region. In the second model, the two outputs of a standard GBC are observed by the respective decoders, but the transmitter observes the sum of the symbols at the receivers using causal feedback. We show that such a feedback has no effect on the capacity region.

## I. INTRODUCTION

It is well known that the capacity region of a Gaussian broadcast (GBC) can be enlarged by utilizing causal feedback from the receivers, except in the physically degraded case. Such enlargements are also possible with several classes of noisy feedback models, rate-limited feedback links etc. The relevant information can be found in [1]–[9]. We consider passive feedback in this paper, where the received symbols are as such fed back by the receiver, albeit through feedback links corrupted by additive white Gaussian noise (AWGN). In this context, the results of [3] imply that noisy feedback from even one of the receivers is enough to enlarge the GBC capacity region, when the receivers have independent and identical noise processes. However, in the asymmetric situation, where one user is stronger compared to other, it was shown in [10] that with noisy feedback only from the strong receiver, no such enlargement is possible when the feedback noise variance is above a threshold. A sharp characterization of the feedback noise threshold for capacity enlargement with one-sided feedback was presented in [11]. A tight characterization of the noise variances for which two-sided noisy feedback is

useful in capacity enlargement is presented in ‘the unpublished manuscript’ [12].

In the present paper, we consider two feedback models in the GBC setting, and provide sharp characterizations of when feedback is useful for capacity enlargement. In our first model (see Fig. 1), there are two receivers demanding independent information from a common transmitter. Each receiver observes the respective signals forwarded by two intermediate nodes, which we call the *repeater* nodes (marked as  $a$  and  $b$  in Fig. 1). A repeater does not decode the information, but simply forwards the band-limited received signal in a different frequency band. The transmissions from each repeater serve two purposes. Firstly, the corresponding receiver gets the signal via a noisy link. Secondly, the original transmitter also gets feedback signals from each repeater. If the repeaters use different frequency bands, the model shown in Fig. 1 becomes relevant. Furthermore, the model generalizes the existing passive feedback models in [10], [11] and [12], and effectively subsumes the results there. While our proof techniques build on [12], for both achievability as well as converse, the generalizations here necessitate additional steps and different analytical computations, which are more involved.

Our second model is that of a GBC with additive multiple access channel (MAC) based feedback. This system has some resemblance to the feedback model in [4], where it is shown that active feedback is useful in enlarging the capacity region, when feedback to the encoder is through a MAC link. On the contrary, we show that passive MAC feedback has no effect on the GBC capacity region, a novel converse construction being the key to this result. From a physical layer perspective, having a BC in the forward direction, along with MAC based feedback, is suitable for some downlink-uplink communication systems.

We will now explain the system model in detail, and present the main results.

## II. SYSTEM MODEL AND MAIN RESULTS

We consider two models of the feedback. The first model is best explained using a broadcast system with two intermediate receiving nodes. Let  $\tilde{Y}_1 = X + \tilde{Z}_1$  and  $\tilde{Y}_2 = X + \tilde{Z}_2$  be the respective received symbols at the two intermediate nodes when  $X$  is the transmitted symbol. The actual receiver  $k \in \{1, 2\}$

SRBP acknowledges the support from DST India IMPRINT grant 001280. Vinod Prabhakaran was supported by the Department of Atomic Energy, Government of India, under project no. RTI4001.

in our system observes  $Y_k = \tilde{Y}_k + \hat{Z}_k$  from which a private message  $W_k \in [1 : 2^{nR_k}]$  intended to it has to be decoded from  $n$  channel uses. Causal feedback of  $(\tilde{Y}_1 + Z_{fb1}, \tilde{Y}_2 + Z_{fb2})$  is available at the transmitter, see Fig. 1. The noise vector  $(\tilde{Z}_1, \hat{Z}_1, \tilde{Z}_2, \hat{Z}_2, Z_{fb1}, Z_{fb2})$  is generated from an i.i.d process according to  $\mathcal{N}(0, \text{diag}(\tilde{\sigma}_1^2, \hat{\sigma}_1^2, \tilde{\sigma}_2^2, \hat{\sigma}_2^2, \sigma_{fb1}^2, \sigma_{fb2}^2))$ , independent of the messages as well as the transmissions till that instant. Essentially, decoder  $k$  receives  $Y_k = X + Z_k$  with  $Z_k = \tilde{Z}_k + \hat{Z}_k$ , whereas  $X + \tilde{Z}_k$  is passively fed-back from receiver  $k$  through a noisy link. A transmit power constraint of  $\sum_{i=1}^n \mathbb{E}|X_i|^2 \leq nP$  is imposed on the transmissions in each block. Without loss of generality, we take user 1 as the stronger receiver in the stochastic sense, i.e.  $\sigma_1^2 \triangleq \tilde{\sigma}_1^2 + \hat{\sigma}_1^2 \leq \tilde{\sigma}_2^2 + \hat{\sigma}_2^2 \triangleq \sigma_2^2$ .

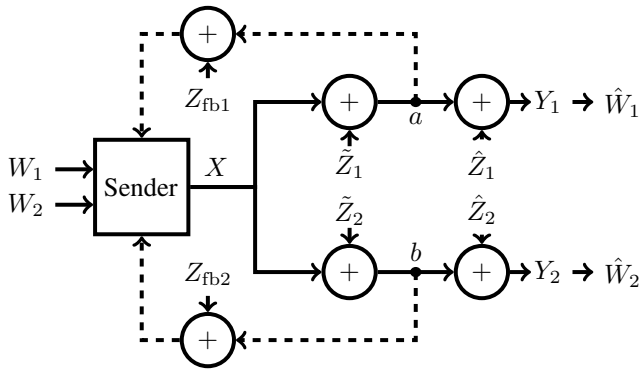

Fig. 1. Gaussian BC with (causal) noisy feedback

Using standard information theoretic definitions [13], which are not repeated here, let us directly define our main objective. The capacity region of the above GBC with feedback, denoted as  $C^{\text{noisy-fb}}$ , is the collection of rate-pairs  $(R_1, R_2)$  such that the decoding error probability for the uniformly chosen message pair  $(W_1, W_2) \in \{[1 : 2^{nR_1}] \times [1 : 2^{nR_2}]\}$  at the respective users can be made vanishingly small, possibly by taking the blocklength  $n$  large enough. Also, let  $C^{\text{wo-fb}}$  denote the capacity region in the absence of feedback. Our first main result is stated now.

**Theorem 1.** Consider the set of noise variances  $(\tilde{\sigma}_1^2, \hat{\sigma}_1^2, \tilde{\sigma}_2^2, \hat{\sigma}_2^2, \sigma_{fb1}^2, \sigma_{fb2}^2)$  with  $\sigma_1^2 = \tilde{\sigma}_1^2 + \hat{\sigma}_1^2$  and  $\sigma_2^2 = \tilde{\sigma}_2^2 + \hat{\sigma}_2^2$ . If

$$\left( \frac{1}{\sigma_1^2} - \frac{\tilde{\sigma}_1^4}{\sigma_1^4(\tilde{\sigma}_1^2 + \sigma_{fb1}^2)} \right) \left( \frac{1}{\sigma_2^2} - \frac{\tilde{\sigma}_2^4}{\sigma_2^4(\tilde{\sigma}_2^2 + \sigma_{fb2}^2)} \right) \geq \frac{1}{\sigma_2^4}, \quad (1)$$

then the capacity region  $C^{\text{noisy-fb}}$  is same as that without feedback. Conversely, if the set of noise variances does not satisfy the above condition,  $C^{\text{noisy-fb}}$  strictly contains the no-feedback capacity region  $C^{\text{wo-fb}}$ .

The following two corollaries respectively address the special cases with  $(\hat{\sigma}_1^2 = \hat{\sigma}_2^2 = 0)$  and  $(\sigma_{fb1}^2, \sigma_{fb2}^2) = (0, 0)$ . The first can be obtained by taking  $\hat{\sigma}_1^2 = \hat{\sigma}_2^2 = 0$  in Theorem 1, and the second by taking  $\sigma_{fb1}^2 = \sigma_{fb2}^2 = 0$ .

**Corollary 2** (Theorem 1 in [12]). With  $\hat{\sigma}_1^2 = \hat{\sigma}_2^2 = 0$ , the capacity region is not enlarged if and only if

$$\frac{\tilde{\sigma}_2^2}{\sigma_{fb1}^2} \geq \left( \frac{\tilde{\sigma}_1^2}{\sigma_{fb1}^2} + 1 \right) \left( \frac{\tilde{\sigma}_2^2}{\sigma_{fb2}^2} + 1 \right). \quad (2)$$

**Corollary 3.** With  $\sigma_{fb1}^2 = \sigma_{fb2}^2 = 0$ , the capacity region is not enlarged if and only if

$$1 + \frac{\tilde{\sigma}_1^2}{\hat{\sigma}_1^2} \leq \frac{\hat{\sigma}_2}{\hat{\sigma}_1}. \quad (3)$$

Notice the mildly surprising aspect that  $\tilde{\sigma}_2^2$  does not play a direct role in Corollary 3. Furthermore, observe that the condition in (3) is equivalent to  $\sigma_1^2 \leq \hat{\sigma}_1 \hat{\sigma}_2$ .

The second model that we consider in this paper is also derived from a standard GBC having input  $X$  and the two outputs  $(Y_1, Y_2) = (X + Z_1, X + Z_2)$ , with  $Z_1$  and  $Z_2$  independent of each other. The transmissions should obey an average power constraint. The signal  $Y_1 + Y_2$  is made available at the encoder via causal feedback, as depicted in Fig. 2. The

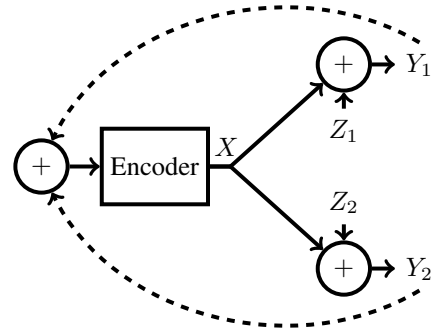

Fig. 2. GBC with passive additive MAC feedback

following is our main result for the second model.

**Theorem 4.** In a Gaussian BC with passive additive MAC feedback, the capacity region is unchanged by the presence of feedback.

In the coming sections, we provide the proofs for Theorem 1 and Theorem 4.

### III. CONVERSE TO THEOREM 1

Ever since the original converse results for the scalar broadcast channel [14], [15], the idea of converting a stochastic degraded model to an equivalent physically degraded system was used as a key step, in the absence of feedback. This aids in identifying an auxiliary variable which facilitates the single letterization of the rate region, or enables the application of Entropy Power Inequality (EPI) in the Gaussian setting. In the one-sided feedback setting of [10], while the degradation is not obvious, one can still find a physically degraded equivalent model using vector outputs. This strategy as such seems to fail when there is feedback from both the receivers. Nevertheless, that we can still find the capacity region of a class of two

sided feedback models is the surprising result in [12]. This is achieved by introducing careful side information created from the noise realizations, at the two receivers. We generalize this technique here to construct an outer-bound to the capacity region and, as we will show later, this is tight under the condition in (1). In particular, our converse result equips each receiver with a careful assortment of the noise-processes, allowing the analytical construction of a single letter formula, which turns out to have a form amenable to the application of EPI. Notice however that we aren't directly identifying any equivalent physically degraded BC model.

From Fano's inequality, after suppressing the  $o(n)$  terms,

$$\begin{aligned}
nR_1 &\leq I(W_1; Y_1^n | W_2) \\
&\leq I(W_1; Y_1^n, \tilde{Z}_1^n - \frac{\tilde{\sigma}_1^2}{\hat{\sigma}_1^2} \hat{Z}_1^n, Z_{fb1}^n, \tilde{Z}_2^n + Z_{fb2}^n | W_2) \\
&\stackrel{(a)}{=} \sum_{i=1}^n I(W_1; Y_{1i} | U_i, Y_1^{i-1}, \tilde{Z}_1^{i-1} - \frac{\tilde{\sigma}_1^2}{\hat{\sigma}_1^2} \hat{Z}_1^{i-1}, Z_{fb1}^{i-1}) \\
&\leq \sum_{i=1}^n h(Y_{1i} | U_i, Y_1^{i-1}, \tilde{Z}_1^{i-1} - \frac{\tilde{\sigma}_1^2}{\hat{\sigma}_1^2} \hat{Z}_1^{i-1}, Z_{fb1}^{i-1}) - h(Z_{1i}) \\
&\stackrel{(b)}{\leq} \sum_{i=1}^n h(Y_{1i} | U_i, T_i) - h(Z_{1i}), \tag{4}
\end{aligned}$$

where we took

$$T_i \triangleq X^{i-1} + (1 - \gamma_1) \tilde{Z}_1^{i-1} + (1 + \gamma_1 \beta) \hat{Z}_1^{i-1} - \gamma Z_{fb1}^{i-1}$$

in step (b) with  $\beta \triangleq \frac{\tilde{\sigma}_1^2}{\hat{\sigma}_1^2}$ . In (a), we used the definition  $U_i \triangleq (W_2, \tilde{Z}_2^{i-1} + Z_{fb2}^{i-1})$ , and the fact that the noise terms  $(\tilde{Z}_{1i} - \beta \hat{Z}_{1i}, Z_{fb2i}, \tilde{Z}_{2i} + Z_{fb2i})$  are independent of  $(W_1, W_2, Y_1^i, \tilde{Z}_1^{i-1} - \beta \hat{Z}_1^{i-1}, Z_{fb1}^{i-1}, \tilde{Z}_2^{i-1} + Z_{fb2}^{i-1})$ . Notice that  $Y_{1i}$  is dependent on  $\tilde{Z}_{1i} + \hat{Z}_{1i}$ , however the latter is independent of  $\tilde{Z}_{1i} - \beta \hat{Z}_{1i}$  when  $\beta = \frac{\tilde{\sigma}_1^2}{\hat{\sigma}_1^2}$ .

Now, by ensuring the condition

$$(1 - \gamma_1) \tilde{\sigma}_1^2 - \gamma \sigma_{fb1}^2 = 0, \tag{5}$$

we can also make  $(U_i, (1 - \gamma_1) \tilde{Z}_1^{i-1} + (1 + \gamma_1 \beta) \hat{Z}_1^{i-1} - \gamma Z_{fb1}^{i-1})$  independent of the fed-back noise values  $\tilde{Z}_1^{i-1} + Z_{fb1}^{i-1}$ .

Using Fano's inequality at the weak receiver,

$$\begin{aligned}
nR_2 &\leq I(W_2; Y_2^n) \\
&= h(Y_2^n) - h(Y_2^n | W_2) \\
&= h(Y_2^n) - \sum_{i=1}^n h(Y_{2i} | W_2, Y_2^{i-1}) \\
&\leq h(Y_2^n) - \sum_{i=1}^n h(Y_{2i} | W_2, Y_2^{i-1}, \tilde{Z}_2^{i-1} + Z_{fb2}^{i-1}) \\
&= h(Y_2^n) - \sum_{i=1}^n h(Y_{2i} | U_i, X^{i-1} + Z_2^{i-1} - \gamma_2 (\tilde{Z}_2^{i-1} + Z_{fb2}^{i-1})) \\
&= h(Y_2^n) - \sum_{i=1}^n h(Y_{2i} | U_i, V_i), \tag{6}
\end{aligned}$$

where  $V_i \triangleq (X^{i-1} + \hat{Z}_2^{i-1} + (1 - \gamma_2) \tilde{Z}_2^{i-1} - \gamma_2 Z_{fb2}^{i-1})$  and  $\gamma_2 = \frac{\tilde{\sigma}_2^2}{\tilde{\sigma}_2^2 + \sigma_{fb2}^2}$ . Observe that the pair  $(\hat{Z}_{1i}, \hat{Z}_{2i})$  is independent

of the fed-back signal  $(X_i + \tilde{Z}_{1i} + Z_{fb1i}, X_i + \tilde{Z}_{2i} + Z_{fb2i})$ . From (4) and (7), as long as

$$(1 - \gamma_1)^2 \tilde{\sigma}_1^2 + (1 + \gamma_1 \beta)^2 \hat{\sigma}_1^2 + \gamma^2 \sigma_{fb1}^2 \leq (1 - \gamma_2)^2 \tilde{\sigma}_2^2 + \hat{\sigma}_2^2 + \gamma_2^2 \sigma_{fb2}^2, \tag{8}$$

we can conclude that

$$nR_1 \leq \sum_{i=1}^n h(Y_{1i} | U_i, T_i) - h(Z_{1i}) \tag{9}$$

$$\leq \sum_{i=1}^n h(Y_{1i} | U_i, V_i) - h(Z_{1i}). \tag{10}$$

From (5), the left hand side (LHS) of (8) can be written as

$$f(\gamma_1) \triangleq (1 - \gamma_1)^2 \tilde{\sigma}_1^2 + (1 + \gamma_1 \beta)^2 \hat{\sigma}_1^2 + (1 - \gamma_1)^2 \frac{\tilde{\sigma}_1^4}{\sigma_{fb1}^2}. \tag{11}$$

Choosing the parameter  $\gamma_1$  which minimizes  $f(\gamma_1)$ , we get

$$\gamma_1 = \frac{\tilde{\sigma}_1^4}{\tilde{\sigma}_1^4 (1 + \sigma_{fb1}^2 / \hat{\sigma}_1^2) + \tilde{\sigma}_1^2 \sigma_{fb1}^2}. \tag{12}$$

Substituting (12) and  $\gamma_2 = \frac{\tilde{\sigma}_2^2}{\tilde{\sigma}_2^2 + \sigma_{fb2}^2}$  into (8) yields the condition in (1). Showing the last statement requires some elementary algebra, the details are omitted here. Now we can compare both expressions using a modified version of the EPI [9], which reads

$$2^{\frac{2}{n}} \sum_{i=1}^n h(Y_{2i} | U_i, V_i) \geq 2^{\frac{2}{n}} \sum_{i=1}^n h(Y_{1i} | U_i, V_i) + 2\pi e(\sigma_2^2 - \sigma_1^2). \tag{13}$$

Since  $\frac{n}{2} \log 2\pi e(P + \sigma_2^2) \geq \sum_{i=1}^n h(Y_{2i} | U_i, V_i) \geq h(Z_2^n)$ , we can take

$$\sum_{i=1}^n h(Y_{2i} | U_i, V_i) = \frac{n}{2} \log(2\pi e(\sigma_2^2 + \theta P)), \tag{14}$$

for some  $\theta \in [0, 1]$ . Applying the EPI in (13) yields

$$\sum_{i=1}^n h(Y_{1i} | U_i, V_i) \leq \frac{n}{2} \log(2\pi e(\sigma_1^2 + \theta P)). \tag{15}$$

Using (14)–(15), and the fact that Gaussians maximize entropy under a variance constraint, we get for some  $\theta \in [0, 1]$ ,

$$\begin{aligned}
R_2 &\leq \frac{1}{2} \log \left( 1 + \frac{(1 - \theta)P}{\theta P + \sigma_2^2} \right) \\
R_1 &\leq \frac{1}{2} \log \left( 1 + \frac{\theta P}{\sigma_1^2} \right). \tag{16}
\end{aligned}$$

The region defined by taking union over  $0 \leq \theta \leq 1$  in (16) is indeed the GBC capacity region under no feedback. Thus, the capacity region is not enlarged when the condition in Theorem 1 is met. Some insight to the converse result can be obtained by observing the conditioning variables of (4) and (7). Apart from the common term  $U_i$  there, the terms  $T_i$  and  $V_i$  effectively contain two independent looks of past transmitted symbols. Crucially, the noise processes in these two looks are independent of the noise processes in the feedback loops. This

allowed us to couple the noise realizations in  $(V_i, T_i)$ , without altering the rate bounds.

Let us now construct achievable schemes which enlarge the capacity region, when the set of noise variances does not meet the no-enlargement criterion.

#### IV. ZERO-FORCING ACHIEVABLE SCHEME FOR THEOREM 1

Our idea of achievability is to use the simple linear feedback coding scheme suggested in [11], [12], and show a capacity enlargement whenever feasible. However, the specific parameters of the scheme have to be tuned differently to obtain the results here.

Given blocklength  $2n$ , assume that the message for receiver 1 is encoded by a codeword  $u^n$  and the message for receiver 2 by a codeword  $v^n$ . Also abbreviate  $\tilde{Z}_1 + Z_{\text{fb}1}$  as  $Z_a$  and  $\tilde{Z}_2 + Z_{\text{fb}2}$  as  $Z_b$ . For each  $i \in [1 : n]$ , the transmitter sends the two consecutive inputs

$$\begin{aligned} X_{2i-1} &= u_i + v_i \\ X_{2i} &= \sqrt{\alpha} \left[ u_i - v_i + \beta_1 Z_{a,2i-1} + \beta_2 Z_{b,2i-1} \right]. \end{aligned}$$

To maintain the power constraint, we choose

$$\frac{1}{\alpha} = 1 + \frac{\beta_1^2}{P} (\tilde{\sigma}_1^2 + \sigma_{\text{fb}1}^2) + \frac{\beta_2^2}{P} (\tilde{\sigma}_2^2 + \sigma_{\text{fb}2}^2). \quad (17)$$

**Receiver 1:** In two consecutive instants, the observations are

$$Y_{1,2i-1} = u_i + v_i + Z_{1,2i-1} \quad (18)$$

$$Y_{1,2i} = \sqrt{\alpha} (u_i - v_i + \beta_1 Z_{a,2i-1} + \beta_2 Z_{b,2i-1}) + Z_{1,2i}. \quad (19)$$

A simple *zero forcing* is achieved by computing

$$\begin{aligned} S_{1,i} &\triangleq Y_{1,2i-1} + \frac{Y_{1,2i}}{\sqrt{\alpha}} \\ &= 2u_i + \beta_1 Z_{a,2i-1} + \beta_2 Z_{b,2i-1} + Z_{1,2i-1} + \frac{Z_{1,2i}}{\sqrt{\alpha}}. \end{aligned} \quad (20)$$

**Receiver 2:** Here also we do *zero forcing*. On observing

$$\begin{aligned} Y_{2,2i-1} &= u_i + v_i + Z_{2,2i-1} \\ Y_{2,2i} &= \sqrt{\alpha} (u_i - v_i + \beta_1 Z_{a,2i-1} + \beta_2 Z_{b,2i-1}) + Z_{2,2i} \end{aligned} \quad (21)$$

in two consecutive instants, the receiver computes

$$\begin{aligned} S_{2,i} &\triangleq Y_{2,2i-1} - \frac{Y_{2,2i}}{\sqrt{\alpha}} \\ &= 2v_i - \beta_1 Z_{a,2i-1} - \beta_2 Z_{b,2i-1} + Z_{2,2i-1} - \frac{Z_{2,2i}}{\sqrt{\alpha}}. \end{aligned} \quad (22)$$

By random coding arguments and picking the codesymbols  $u_i$  and  $v_i$  zero-mean Gaussian of variances  $\theta'P$  and  $(1 - \theta')P$ , respectively, the proposed scheme achieves the rates

$$\tilde{R}_1 = \frac{1}{4} \log \left( 1 + \frac{4\theta'P}{\sigma_1^2 \left(1 + \frac{1}{\alpha}\right) + \beta_1^2 \tilde{\sigma}_1^2 + 2\beta_1 \tilde{\sigma}_1^2 + \beta_2^2 \sigma_b^2} \right) \quad (23)$$

$$\tilde{R}_2 = \frac{1}{4} \log \left( 1 + \frac{4(1 - \theta')P}{\sigma_2^2 \left(1 + \frac{1}{\alpha}\right) + \beta_2^2 \sigma_b^2 - 2\beta_2 \tilde{\sigma}_2^2 + \beta_1^2 \sigma_a^2} \right), \quad (24)$$

where we took  $\sigma_a^2 = \tilde{\sigma}_1^2 + \sigma_{\text{fb}1}^2$  and  $\sigma_b^2 = \tilde{\sigma}_2^2 + \sigma_{\text{fb}2}^2$ . Consider an arbitrary quadruple  $(\theta, \theta', \beta_1, \beta_2)$  and define

$$\zeta \triangleq \beta_1^2 \sigma_a^2 + \beta_2^2 \sigma_b^2. \quad (25)$$

By (23)–(24), the pair  $(\tilde{R}_1, \tilde{R}_2)$  (for the parameters  $\theta', \beta_1, \beta_2$ ) dominates the rate pair  $(R_1, R_2)$  on the no-feedback capacity region with the parameter  $\theta \in [0, 1]$  if

$$1 + \frac{4\theta'P}{\sigma_1^2 \left(1 + \frac{1}{\alpha}\right) + 2\beta_1 \tilde{\sigma}_1^2 + \zeta} \geq \left( 1 + \frac{\theta P}{\sigma_1^2} \right)^2 \quad (26)$$

$$1 + \frac{4(1 - \theta')P}{\sigma_2^2 \left(1 + \frac{1}{\alpha}\right) - 2\beta_2 \tilde{\sigma}_2^2 + \zeta} > \left( 1 + \frac{(1 - \theta)P}{\theta P + \sigma_2^2} \right)^2, \quad (27)$$

or equivalently,

$$\frac{4\theta'}{\sigma_1^2 \left(1 + \frac{1}{\alpha}\right) + 2\beta_1 \tilde{\sigma}_1^2 + \zeta} \geq \frac{2\theta}{\sigma_1^2} + \frac{\theta^2 P}{\sigma_1^4} \quad (28)$$

$$\frac{4(1 - \theta')}{\sigma_2^2 \left(1 + \frac{1}{\alpha}\right) - 2\beta_2 \tilde{\sigma}_2^2 + \zeta} > \frac{2(1 - \theta)}{\theta P + \sigma_2^2} + \frac{(1 - \theta)^2 P}{(\theta P + \sigma_2^2)^2}. \quad (29)$$

Let us change the variables from  $(\beta_1, \beta_2, \theta')$  to  $(a_1, a_2, \mu)$  by defining

$$a_j \triangleq (-1)^j \frac{\beta_j}{P} \sqrt{\tilde{\sigma}_j^2 + \sigma_{\text{fb}j}^2}, \quad j = 1, 2 \quad (30)$$

$$\mu \triangleq \frac{1}{P} \left( \frac{\theta'}{\theta} - 1 \right). \quad (31)$$

After doing these transformations we require,

$$\frac{4(1 + \mu P)}{(a_1^2 + a_2^2)(P^2 + P\sigma_1^2) + 2\sigma_1^2 - 2a_1 \frac{\tilde{\sigma}_1^2}{\sigma_a} P} \geq f_1(\theta, P) \quad (32)$$

$$\frac{4(1 - \theta(1 + \mu P))}{(a_1^2 + a_2^2)(P^2 + P\sigma_2^2) + 2\sigma_2^2 - 2a_2 \frac{\tilde{\sigma}_2^2}{\sigma_b} P} > f_2(\theta, P) \quad (33)$$

where

$$\begin{aligned} f_1(\theta, P) &= \frac{2}{\sigma_1^2} + \frac{\theta P}{\sigma_1^4} \\ f_2(\theta, P) &= \frac{2(1 - \theta)}{\theta P + \sigma_2^2} + \frac{(1 - \theta)^2 P}{(\theta P + \sigma_2^2)^2}. \end{aligned}$$

At  $P = 0$ , the LHS of (32) is equal to its right hand side (RHS), the same holds for (33) as well. Therefore, for small values of  $P$ , we can analyze the desired condition by

considering the derivatives at  $P = 0$ . Doing this will result in the following sufficient conditions.

$$2\mu\sigma_1^2 \geq \theta + (a_1^2 + a_2^2)\sigma_1^2 - 2a_1\frac{\tilde{\sigma}_1^2}{\sigma_a}$$

$$(1 - \theta)\left(2a_2\frac{\tilde{\sigma}_2^2}{\sigma_b} - (a_1^2 + a_2^2)\sigma_2^2\right) > (1 - \theta)(1 - 3\theta) + 2\theta\mu\sigma_2^2.$$

The first of the above two can be guaranteed by choosing

$$\mu = \frac{\theta}{2\sigma_1^2} + \frac{a_1^2 + a_2^2}{2} - \frac{a_1\tilde{\sigma}_1^2}{\sigma_1^2\sigma_a}, \quad (34)$$

whereas the second equation, on substitution of (34), will yield

$$a_1^2 + a_2^2 < 2a_1\theta\frac{\tilde{\sigma}_1^2}{\sigma_1^2\sigma_a}$$

$$+ 2a_2(1 - \theta)\frac{\tilde{\sigma}_2^2}{\sigma_2^2\sigma_b} - \frac{\theta^2}{\sigma_1^2} - \frac{(1 - \theta)(1 - 3\theta)}{\sigma_2^2}. \quad (35)$$

Since  $a_1, a_2$  are free parameters, we choose them as

$$a_1 = \frac{\theta\tilde{\sigma}_1}{\sigma_1^2} \text{ and } a_2 = \frac{(1 - \theta)\tilde{\sigma}_2}{\sigma_2^2}, \quad (36)$$

and substitute these in (35) to get

$$\frac{\theta^2}{\sigma_1^2} + \frac{(1 - \theta)(1 - 3\theta)}{\sigma_2^2} - \frac{\theta^2\tilde{\sigma}_1^4}{\sigma_1^4\sigma_a^2} - \frac{(1 - \theta)^2\tilde{\sigma}_2^4}{\sigma_2^4\sigma_b^2} < 0 \quad (37)$$

as a sufficient condition for the chosen  $\theta \in [0, 1]$ . Now, we can choose an appropriate  $\theta$ . In fact, we can choose the  $\theta \in [0, 1]$  which minimizes the LHS of (37), and this results in

$$\left(\frac{1}{\sigma_1^2} - \frac{\tilde{\sigma}_1^4}{\sigma_1^4\sigma_a^2}\right) \left(\frac{1}{\sigma_2^2} - \frac{\tilde{\sigma}_2^4}{\sigma_2^4\sigma_b^2}\right) < \frac{1}{\sigma_2^4}$$

as the required condition. The computational details are omitted here. While capacity enlargements were shown here for small values of  $P$ , this can be easily extended to higher powers, similar to [11].

#### V. GBC WITH PASSIVE MAC FEEDBACK OF THEOREM 4

Let us now consider the GBC with passive MAC feedback model, where  $(Y_1, Y_2)$  are the symbols sent by the two receivers, and the encoder causally observes  $Y_1 + Y_2 + Z$  by feedback, where  $Z$  is an independent AWGN. A similar model was considered in [4], however with active feedback via the MAC link. Let the capacity region of the GBC with passive MAC feedback be  $\mathcal{C}^{w\text{-mac}}$ . We show that  $\mathcal{C}^{w\text{-mac}} = \mathcal{C}^{\text{wo-fb}}$ , where the latter is the no-feedback capacity region. Thus the capacity region is unchanged by the presence of passive MAC feedback. Notice that this fact remains true even with  $Z = 0$  a.e. By Fano's inequality

$$nR_1 \leq I(W_1; Y_1^n | W_2)$$

$$\leq I(W_1; Y_1^n, Z_2^n + Z^n | W_2)$$

$$= \sum_{i=1}^n I(W_1; Y_{1,i} | W_2, Y_1^{i-1}, Z_2^{i-1} + Z^{i-1}), \quad (38)$$

where the last expression utilizes the fact that  $Z_{2i} + Z_i$  is independent of  $(W_2, Y_1^i, Z_2^{i-1} + Z^{i-1})$ . Let us define  $U_i \triangleq$

$(W_2, Y_1^{i-1} + Z_2^{i-1} + Z^{i-1})$ , and notice that for any  $\alpha \neq -1$ , the bound in (38) can be rewritten as:

$$nR_1 \leq \sum_{i=1}^n I(W_1; Y_{1,i} | U_i, Y_1^{i-1} - \alpha(Z_2^{i-1} + Z^{i-1}))$$

$$= \sum_{i=1}^n I(W_1, Y_{1,i} | U_i, X^{i-1} + Z_1^{i-1} - \alpha(Z_2^{i-1} + Z^{i-1})). \quad (39)$$

Let us take  $\alpha = \frac{\sigma_1^2}{\sigma_2^2 + \sigma^2}$ , thus making  $Z_1 + Z_2 + Z$  independent of  $Z_1 - \alpha(Z_2 + Z)$ . Also, the choice of our auxiliary variable yields

$$Y_1^{i-1} + Z_2^{i-1} + Z^{i-1} = U_i = Y_2^{i-1} + Z_1^{i-1} + Z^{i-1}. \quad (40)$$

By Fano's inequality applied at the weak receiver,

$$nR_2 \leq I(W_2; Y_2^n)$$

$$= h(Y_2^n) - h(Y_2^n | W_2)$$

$$\leq h(Y_2^n) - \sum_{i=1}^n h(Y_{2,i} | W_2, Y_2^{i-1}, Z_1^{i-1} + Z^{i-1})$$

$$= h(Y_2^n) - \sum_{i=1}^n h(Y_{2,i} | W_2, Y_2^{i-1} + Z_1^{i-1} + Z^{i-1}, Z_1^{i-1} + Z^{i-1})$$

Using (40), we can write

$$nR_2 \leq h(Y_2^n) - \sum_{i=1}^n h(Y_{2,i} | U_i, Y_2^{i-1} - \beta(Z_1^{i-1} + Z^{i-1})). \quad (41)$$

Choosing  $\beta = \frac{\sigma_2^2}{\sigma_1^2 + \sigma^2}$  will make  $Z_1 + Z_2 + Z \perp\!\!\!\perp Z_2 - \beta(Z_1 + Z)$ . We have almost reached a single letter form. In fact, our choice of  $\alpha$  and  $\beta$  ensures that the  $(Z_1 - \alpha(Z_2 + Z))$  and  $(Z_2 - \beta(Z_1 + Z))$  terms occurring at the conditioning of (39) and (41) can be replaced by independent noise processes, which are also independent of all the other variables employed there. Now if  $\text{Var}[Z_2 - \beta(Z_1 + Z)] \geq \text{Var}[Z_1 - \alpha(Z_2 + Z)]$ , we can replace the conditioning in (39) by  $(U_i, X + Z_2 - \beta(Z_1^{i-1} + Z^{i-1}))$ . In other words, we require

$$\sigma_1^2 + \frac{\sigma_1^4\sigma_2^2}{(\sigma_2^2 + \sigma^2)^2} \leq \sigma_2^2 + \frac{\sigma_2^4\sigma_1^2}{(\sigma_1^2 + \sigma^2)^2}, \quad (42)$$

which is readily verified since  $\sigma_2 \geq \sigma_1$ . The converse proof now follows exactly as in the first model, using the EPI version in [9]. Thus the capacity region remains the same as  $\mathcal{C}_{\text{no-fb}}$ , the no-feedback capacity region.

#### VI. CONCLUSION

We have analyzed two GBC models with passive noisy feedback, and characterized the necessary and sufficient conditions under which the capacity region is not enlarged.

## REFERENCES

- [1] Y. Wu and M. Wigger, "Coding schemes with rate-limited feedback that improve over the no feedback capacity for a large class of broadcast channels," *IEEE Transactions on Information Theory*, vol. 62, no. 4, pp. 2009–2033, 2016.
- [2] O. Shayevitz and M. Wigger, "On the capacity of the discrete memoryless broadcast channel with feedback," *IEEE Transactions on Information Theory*, vol. 59, no. 3, pp. 1329–1345, 2012.
- [3] R. Venkataramanan and S. S. Pradhan, "An achievable rate region for the broadcast channel with feedback," *IEEE Transactions on Information Theory*, vol. 59, no. 10, pp. 6175–6191, 2013.
- [4] A. Ben-Yishai and O. Shayevitz, "The AWGN BC with MAC feedback: A reduction to noiseless feedback via interaction," in *2015 IEEE Information Theory Workshop (ITW)*, 2015, pp. 1–5.
- [5] S. B. Amor, Y. Steinberg, and M. Wigger, "MAC-BC duality with linear-feedback schemes," in *2014 IEEE International Symposium on Information Theory*. IEEE, 2014, pp. 1737–1741.
- [6] L. Ozarow and S. Leung-Yan-Cheong, "An achievable region and outer bound for the Gaussian broadcast channel with feedback (corresp.)," *IEEE Transactions on Information Theory*, vol. 30, no. 4, pp. 667–671, 1984.
- [7] G. Dueck, "Partial feedback for two-way and broadcast channels," *Information and Control*, vol. 46, no. 1, pp. 1–15, 1980.
- [8] A. El Gamal, "The feedback capacity of degraded broadcast channels (corresp.)," *IEEE Transactions on Information Theory*, vol. 24, no. 3, pp. 379–381, 1978.
- [9] —, "The capacity of the physically degraded Gaussian broadcast channel with feedback (corresp.)," *IEEE Transactions on Information Theory*, vol. 27, no. 4, pp. 508–511, 1981.
- [10] S. R. B. Pillai and V. M. Prabhakaran, "On the noisy feedback capacity of Gaussian broadcast channels," in *2015 IEEE Information Theory Workshop (ITW)*. IEEE, 2015, pp. 1–5.
- [11] A. N. Ravi, S. R. B. Pillai, V. M. Prabhakaran, and M. Wigger, "When does partial noisy feedback enlarge the capacity of a Gaussian broadcast channel?" in *2020 IEEE International Symposium on Information Theory (ISIT)*, 2020, pp. 1480–1485.
- [12] —, "On the capacity enlargement of Gaussian broadcast channels with passive noisy feedback," *Submitted to IEEE Transactions on Information Theory*, <http://arxiv.org/abs/2009.08765>, 2020.
- [13] A. El Gamal and Y.-H. Kim, *Network Information Theory*. Cambridge university press, 2011.
- [14] R. G. Gallager, "Capacity and coding for degraded broadcast channels," *Problems Inform. Transmission*, vol. 10, no. 3, pp. 185–193, 1974.
- [15] P. Bergmans, "A simple converse for broadcast channels with additive white Gaussian noise (corresp.)," *IEEE Transactions on Information Theory*, vol. 20, no. 2, pp. 279–280, 1974.