



**HAL**  
open science

# Integration of multi-objective reliability-based design optimization into thermal energy management: Application on phase change material-based heat sinks

B. Debich, A. Yaich, K. Dammak, A. El Hami, W. Gafsi, L. Walha, M. Haddar

## ► To cite this version:

B. Debich, A. Yaich, K. Dammak, A. El Hami, W. Gafsi, et al.. Integration of multi-objective reliability-based design optimization into thermal energy management: Application on phase change material-based heat sinks. *Journal of Energy Storage*, 2021, 41, pp.102906. 10.1016/j.est.2021.102906 . hal-03348502

**HAL Id: hal-03348502**

**<https://hal.science/hal-03348502>**

Submitted on 2 Aug 2023

**HAL** is a multi-disciplinary open access archive for the deposit and dissemination of scientific research documents, whether they are published or not. The documents may come from teaching and research institutions in France or abroad, or from public or private research centers.

L'archive ouverte pluridisciplinaire **HAL**, est destinée au dépôt et à la diffusion de documents scientifiques de niveau recherche, publiés ou non, émanant des établissements d'enseignement et de recherche français ou étrangers, des laboratoires publics ou privés.



Distributed under a Creative Commons Attribution - NonCommercial 4.0 International License

# Integration of multi-objective reliability-based design optimization into thermal energy management: Application on phase change material-based heat sinks

B. Debich<sup>a,b,\*</sup>, A. Yaich<sup>c</sup>, K. Dammak<sup>a</sup>, A. El Hami<sup>a</sup>, W. Gafsi<sup>b</sup>, L. Walha<sup>b</sup>, M. Haddar<sup>b</sup>

<sup>a</sup>Laboratory of Mechanics of Normandy (LMN), INSA Rouen, University of Rouen, 76801, St Etienne de Rouvray, France

<sup>b</sup>Mechanical Modeling and Manufacturing Laboratory (LA2MP), National School of Engineers of Sfax, University of Sfax, 3038, Sfax, Tunisia

<sup>c</sup>Institut Clement Ader(ICA), Universite de Toulouse, CNRS/INSA/ISAE/Mines Albi/UPS, Toulouse, France

---

## Abstract

Phase change material-based heat sinks are widely used in several industrial applications such as in the field of industrial automation and mechatronics. Nowadays, several researchers aim to obtain an optimal design of these systems in order to ameliorate its performances. Nevertheless, uncertainties are not considered for the majority of these studies. Furthermore, it has been confirmed that deterministic multi-objective optimization (DMOO) may lead to an unreliable design. In this study, a new methodology that leads to perform the Multi-Objective Reliability-Based Design Optimization (MORBDO) for thermal management of a passive cooling system is proposed. It consists in coupling the Finite Element Model (FEM), MORBDO procedures and surrogate approaches. Kriging predictor is used to construct metamodels and then validated using Cross-Validation (CV) and error predictions. A numerical investigation is carried out to study the different DMOO and MORBDO approaches. In this study, a 3D PCM-based round pin-fin heat sink is detailed. The aim of this problem is to minimize two objective functions: the cost (total volume  $V$ ) and the final cooling time  $t_f$  by considering both thermal and physical constraints. For this purpose, geometrical uncertain parameters are considered such as length  $L$ , height  $H$  and  $\phi$  pin diameter of the heat sink. This study leads to develop a well-distributed reliable Pareto solutions by combining the Robust Hybrid Method (RHM) and the Constrained Non-dominated Sorting Genetic Algorithm (C-NSGA-II). Then, the efficiency of the proposed MORBDO-RHM approach for PCM-based heat sink is verified.

**Keywords:** Thermal energy management; PCM-based heat sinks; Kriging approach; Pareto optimal front; C-NSGA-II; MORBDO-RHM.

---

\*Corresponding author

Email address: [bessem.debich@insa-rouen.fr](mailto:bessem.debich@insa-rouen.fr) (B. Debich)

Preprint submitted to "Journal of Energy Storage"

May 17, 2021

## Nomenclature

### Abbreviations

ANN	Artificial neural networks
Cov	Covariance
CV	Cross-validation
DDO	Deterministic design optimization
DOE	Design of experiments
FES	Finite element simulation
HDS	Hybrid design space
HM	Hybrid method
HS	Heat sink
HSU	Heat storage unit
LHS	Latin hypercube sampling
MAE	Maximum absolute error
MCS	Monte Carlo simulation
MHM	Modified hybrid method
MSE	Mean squares error
PCM	Phase change material
QRS	Quadratic response surface
RBDO	Reliability-based design optimization
RHM	Robust hybrid method
RME	Relative mean error
RMSE	Root mean squared error
RSM	Response surface methodology
SPTs	Set point temperatures
TM	Thermal management

### Symbols

$\hat{y}(\mathbf{x})$	The predictor of the model
$\mathbf{F}$	Model matrix
$\mathbf{f}(\mathbf{x})$	Vector of regression basis function
$\mathbf{K}$	Matrix of correlation functions
$\mathbf{r}(\mathbf{x})$	Vector of correlation functions
$\mathbf{x}$	Design variables vector
$\mathbf{x}_s$	Set of samples
$\mathbf{y}_s$	Responses of the sample set
$A_m$	Mushy region
$C_p$	Specific heat of fusion
$f(x)$	Objective function
$g$	Gravitational acceleration
$G_i(x, y)$	Performance functions
$H$	Height of heat sink
$H$	Total enthalpy of PCM
$h_s$	Specific enthalpy
$h_j(x)$	Deterministic constraints
$h_{s,ref}$	Referential enthalpy
$L$	length of heat sink

$L_f$	Latent heat of fusion
$lb$	Lower bound
$m$	Dimensional problem
$n$	Number of design points
$P$	Pressure
$p$	Number of kriging coefficients
$P_i^T$	Target failure probability
$Pr[.]$	Probability operator
$S$	Source term
$S_g$	Global safety factor
$S_h$	Energy source term
$T$	Temperature
$t$	Time
$T_l$	Liquid temperature
$T_s$	Solid temperature
$T_{amb}$	Ambient temperature
$T_{max}$	Maximum temperature
$T_{ref}$	Referential temperature
$u, v, w$	Velocity components in $x, y$ and $z$ directions
$ub$	Upper bound
$V$	Volume
$x$	Deterministic design variables
$x^*$	Optimal point
$y$	Random variables
$y^*$	Failure point
$Z(\mathbf{x})$	Stochastic process

### Greek symbols

$\alpha_w$	Thermal expansion coefficient
$\beta_t$	Target reliability level
$\boldsymbol{\beta}$	Vector of regression coefficients
$\boldsymbol{\theta}$	Vector of the correlation function parameters
$\Delta H$	Latent heat
$\lambda$	Thermal conductivity
$\mu$	Dynamic viscosity
$\phi$	Pin fin diameter
$\rho$	Density
$\sigma^2$	Variance of the stochastic model
$\varepsilon$	Normal random error
$\xi$	Liquid fraction of PCM
$d_\beta(x, y)$	Distance between the optimal and design points
$L(\boldsymbol{\beta}, \sigma^2, \boldsymbol{\theta})$	Likelihood function

## 1. Introduction

In recent years, thermal management in the field of mechatronics has become an important factor for researchers in electronic packages design. In this context, electronic components are getting ever-smaller with more design features in size due to the development of modern technologies of electronic equipment. In fact, a high power and performance dissipated by the electronic component can lead, not only to reduce their lifetime, but also to its immediate failure. To this end, an efficient and novel cooling technology is needed to overcome the overheating phenomenon and to avoid the deterioration of the device. Furthermore, the choice of such a cooling system is based on many factors such as material cost, heat dissipation rate, maintenance and space [1].

In the literature, several technics of passive cooling are developed to ensure the smooth operation of electronic devices using PCM-based heat sinks [2–4]. However, standard cooling methods would not be sufficient. Therefore, to improve the performance of passive cooling electronic device technologies, many studies are developed and some of them are based on Phase Change Materials (PCM) [5, 6]. An experimental study is investigated in [7], to improve and ensure the reliability and functionality of the installed features. A parametric study leads to improve the thermal performance of PCM-based heat sinks by changing the PCM volume fraction and pin thickness at various heat fluxes. A numerical and experimental studies are presented by Thomas et al. [8] in order to evaluate the thermal performance of a PCM-based heat sink using n-Eicosane at many constant input power levels. In this study, the effect of natural convection has been discussed. Nowadays, PCM-based heat sink optimization presents a huge challenge for developers. A numerical study is presented in [9] which an optimal model is proposed in a passive cooling application using PCM-based plate fin matrix for charging and discharging phases. The main purpose of this study is to improve the thermal performance of the heat storage unit (HSU) by changing the input power level, PCM material, PCM volume fraction and heat sink geometry.

Integration of reliability methods in the optimization algorithm presents a new challenge in mechatronics problem. The Reliability-Based Design Optimization (RBDO) aims then to find the best compromise between cost and safety [10]. In this context, an efficient RBDO study for PCM-based heat-sink is presented in [11, 12]. These studies lead to determine an optimal and reliable design of a cooling system where two-dimensional Finite Element Simulations (FES) are performed. These studies prove that, Deterministic Design Optimization (DDO) approach leads to determine an optimal solution, but it represents a missing level of confidence and a significant risk of failure, due to non-considering uncertainties. Hence, to overcome this issue, it is recommended to integrate, during the optimization process, the reliability analysis. Using the classical RBDO approach and, to obtain optimal results, coupling of physical space and normalized space is needed. Which means a high computation time for such an optimization problem [13–15]. In order to overcome this issue, Kharmanda et al. [16] proposed a novel RBDO methodology called Hybrid reliability-optimization Method (HM) where its efficiency is presented and discussed. This method

56 efficiently reduces the computing time comparing with the classical approach. However, the  
57 optimization problem becomes more complex and then it can lead to an infeasible solution.  
58 In order to solve the difficulties of the classical one, Yaich et al. [17] proposed a novel  
59 methodology called Robust Hybrid Method (RHM). The efficiency of this method has been  
60 verified only on static and some specific nonlinear cases such as fatigue damage [17], coupled  
61 acoustic-structural system [18, 19] and shape memory alloy micro-pump [20]. In addition,  
62 in [21, 22], the authors aim to develop a new approach applied to an offshore wind turbine,  
63 which it called Modified Hybrid Method (MHM) in order to avoid issues of other RBDO  
64 methods.

65  
66 Otherwise, such an RBDO method needs a large number of evaluations. In the case  
67 of PCM-based heat sink, a non-linear transient 3D model analysis is expensive in term of  
68 computational time. To this end, surrogate models are then recommended as an alternative  
69 to define original models' approximations. It consists in constructing mathematical models,  
70 to determine the link between inputs and outputs of a specified system [23, 24]. Recent  
71 approaches are developed in the field of design optimization [25] and probabilistic analysis  
72 [26, 27], using surrogate models. Response Surface Methodology (RSM), Artificial Neural  
73 Networks (ANN), Radial Basis Function (RBF) method and Kriging method are the most  
74 popular surrogate modelling used recently. In [28], metamodels are applied in the field of  
75 mechanical manufacturing for the purpose to enhance the computational efficiency. Also,  
76 Fatma et al. [29] studied many metamodel techniques for a NiTi micro actuator. A Monte  
77 Carlo Simulations (MCS) are then performed in order to prove its efficiency, using the  
78 constructed metamodel. These studies demonstrate that kriging method presents more  
79 efficiently and gives the best approximation of the original model. Recently, Dammak  
80 and El Hami [30, 31] studied a numerical application of a cementless hip prosthesis and  
81 a coupled acoustic-structural system. These studies are based on coupling multi-objective  
82 optimization problem (MORBDO) with surrogate models. It has been demonstrated that  
83 the studied problem using Kriging approach has the ability to generate a well-distributed  
84 reliable Pareto solution.

85  
86 The aim of this paper is to propose a new methodology that leads to determine an  
87 optimal design of a PCM-based round pin-fin heat sink with a required reliability level. Both  
88 deterministic and multi-objective reliability optimization are presented. For this purpose,  
89 the Constrained Non-dominated Sorting Genetic Algorithm (C-NSGA-II) is coupled with  
90 HM and RHM approaches respectively. DMOO and MORBDO models are next coupled  
91 with surrogate models which considerably reduced the computing time. To present the  
92 advantages of the proposed method, a detailed numerical application of PCM-based round  
93 pin-fin heat sink is investigated. Results show the improvement of the resulting optimal  
94 solution using MORBDO-RHM coupled with Kriging surrogate model, and its capability to  
95 develop a well-distributed reliable Pareto solutions with a required reliability level.

96 **2. Heat transfer and PCM behavior: Mathematical model**

97 The heat generated by the input power is transferred to all surfaces of heat sink by  
 98 conduction. In fact, PCM allows energy to be absorbed by changing from the solid state to  
 99 the liquid state. The dissipated energy by the PCM causes its transformation from liquid to  
 100 solid state. It is supposed that thermo-physical properties of the PCM are independent of  
 101 temperature and only the conduction equation is taken into consideration for the aluminum  
 102 section as presented in [equation \(1\)](#):

103 • **Energy conservation:**

$$\rho C_p \left( \frac{\partial T}{\partial t} + u \frac{\partial T}{\partial x} + v \frac{\partial T}{\partial y} + w \frac{\partial T}{\partial z} \right) = \lambda \left( \frac{\partial^2 T}{\partial x^2} + \frac{\partial^2 T}{\partial y^2} + \frac{\partial^2 T}{\partial z^2} \right) + S_h \quad (1)$$

104 Where,  $\rho$ ,  $C_p$  and  $\lambda$  are respectively the density, specific heat of fusion and thermal conductivity  
 105 of aluminum.

106 The latent heat storage is presented by the energy source term  $S_h$  due to melting and it is  
 107 presented as follow:

$$S_h = -\frac{\partial}{\partial t}(\rho \Delta H) \quad (2)$$

108 The total enthalpy of PCM can be calculated as the sum of the latent heat  $\Delta H$  and the  
 109 specific enthalpy  $h_s$ :

$$H = \Delta H + h_s \quad (3)$$

110 As mentioned in [equation \(3\)](#), the specific enthalpy  $h_s$  can be defined as follows:

$$h_s = \int_{T_{ref}}^T C_p dT + h_{s,ref} \quad (4)$$

111 Additionally, the latent heat  $\Delta H$  is calculated as follows:

$$\Delta H = \xi L_f \quad (5)$$

112 As mentioned in [equation \(5\)](#),  $L_f$  and  $\xi$  refer to latent heat of fusion and liquid fraction of  
 113 PCM respectively. In fact, the parameter  $\xi$  presents the liquid quantity relative to the total  
 114 volume of PCM and can be defined as below:

$$\xi = \begin{cases} 0 & \text{if } T \leq T_s \\ \frac{T-T_s}{T_l-T_s} & \text{if } T_s < T < T_l \\ 1 & \text{if } T \geq T_l \end{cases} \quad (6)$$

115 According to [equations \(3\) to \(5\)](#), the total enthalpy of PCM  $H$  can be calculated by:

$$H = \int_{T_{ref}}^T C_p dT + h_{s,ref} + \xi L_f \quad (7)$$

116 The governing equations of mass and momentum conservation are defined as follow:

117 • **Mass conservation:**

$$\frac{\partial \rho}{\partial t} + \frac{\partial(\rho u)}{\partial x} + \frac{\partial(\rho v)}{\partial y} + \frac{\partial(\rho w)}{\partial z} = 0 \quad (8)$$

118 Note that  $u$ ,  $v$  and  $w$  present velocity components in  $x$ ,  $y$  and  $z$  directions, respectively.  
 119 Furthermore, it is considered that the PCM in the liquid phase is an incompressible Newtonian  
 120 fluid the fact that the density of the PCM is considered unchangeable for any fluid particle  
 121 ( $\frac{\partial \rho}{\partial t} = 0$ ). So, the previous equation is reduced to:

$$\frac{\partial(\rho u)}{\partial x} + \frac{\partial(\rho v)}{\partial y} + \frac{\partial(\rho w)}{\partial z} = 0 \quad (9)$$

122 • **Momentum conservation:**

$$\rho \left( \frac{\partial u}{\partial t} + \frac{\partial(u^2)}{\partial x} + \frac{\partial(uv)}{\partial y} + \frac{\partial(uw)}{\partial z} \right) = -\frac{\partial P}{\partial x} + \mu \left[ \frac{\partial^2 u}{\partial x^2} + \frac{\partial^2 u}{\partial y^2} + \frac{\partial^2 u}{\partial z^2} \right] + S \cdot u \quad (10)$$

$$\rho \left( \frac{\partial v}{\partial t} + \frac{\partial(uv)}{\partial x} + \frac{\partial(v^2)}{\partial y} + \frac{\partial(vw)}{\partial z} \right) = -\frac{\partial P}{\partial y} + \mu \left[ \frac{\partial^2 v}{\partial x^2} + \frac{\partial^2 v}{\partial y^2} + \frac{\partial^2 v}{\partial z^2} \right] + S \cdot v \quad (11)$$

$$\rho \left( \frac{\partial w}{\partial t} + \frac{\partial(uw)}{\partial x} + \frac{\partial(vw)}{\partial y} + \frac{\partial(w^2)}{\partial z} \right) = -\frac{\partial P}{\partial z} + \mu \left[ \frac{\partial^2 w}{\partial x^2} + \frac{\partial^2 w}{\partial y^2} + \frac{\partial^2 w}{\partial z^2} \right] - \rho g \alpha_w (T - T_s) + S \cdot w \quad (12)$$

125 Where,  $\mu$  presents the dynamic viscosity,  $\alpha_w$  is the thermal expansion coefficient,  $P$  is  
 126 the pressure and  $g$  is the gravitational acceleration. Due to the gravitational acceleration  
 127 direction (negative  $z$ -direction), the Boussinesq approximation is determined by adding  
 128  $\rho g \alpha_w (T - T_s)$  term as presented in [equation \(12\)](#).

129 The following equation presents the source term  $S$ :

$$S = \frac{(1 - \xi)^2}{(\xi^3 + \varepsilon)} A_m \quad (13)$$

130 To avoid division by zero in [equation \(13\)](#), a small positive parameter  $\varepsilon$  is used ( $\varepsilon = 10^{-10}$ ).  
 131 The constant  $A_m$  presents the consecutive number in the mushy region and it is recommended  
 132 to take  $A_m = 10^5$  in several studies [[32–34](#)].

133 Mathematical models in this study can be founded in Wang and Yang [[32, 33](#)], Shatikian  
 134 et al. [[34](#)] and Nayak et al. [[35](#)]. They evaluated the performance of thermal management  
 135 based on PCM in internal fins.

### 136 3. Surrogate models

#### 137 3.1. Description of surrogate modeling process

138 Recently, metamodels are widely used in current engineering analysis in order to reduce  
 139 the calculation cost. Surrogate models aim to construct the mathematical approximations

140 to estimate system behaviour and to define the relationship between inputs and outputs of  
 141 the system [24]. The most used surrogate modelling methods are Radial Basis Function  
 142 (RBF) method, Response Surface Methodology (RSM), Artificial Neural Networks (ANN)  
 143 and Kriging method [23, 24]. Several researches [28–30] demonstrate that the Kriging  
 144 approach leads to a best approximation to a finite element analysis particularly for non-  
 145 linear problems. In this study, Kriging metamodel method is used to evaluate the outputs  
 146 of PCM-based heat sink in order to improve the computational efficiency.

147  
 148 In the beginning, let us consider a  $n$ -dimensional problem. Table 1 presents the description  
 149 of all parameters used in this problem.

Table 1: Description of all used parameters

Notation	Designation	Dimension	Vector
$x$	design variable vector	$1 \times n$	$x_1, x_2, \dots, x_n$
$x_s$	set of samples	$n \times 1$	$x_s = \{x^{(1)}, x^{(2)}, \dots, x^{(n)}\}^T$
$y_s$	outputs responses of the samples set	$n \times 1$	$y_s = \{y^{(1)}, y^{(2)}, \dots, y^{(n)}\}^T = \{y(x^{(1)}), y(x^{(2)}), \dots, y(x^{(n)})\}^T$

150 The sampled data set is indicated by the pair  $(x_s, y_s)$  in the vector space. The main aim  
 151 of surrogate modeling is to build a meta-model in order to predict the output for any point  
 152  $x$ , thus, to estimate  $y(x)$  based on the pair  $(x_s, y_s)$ .

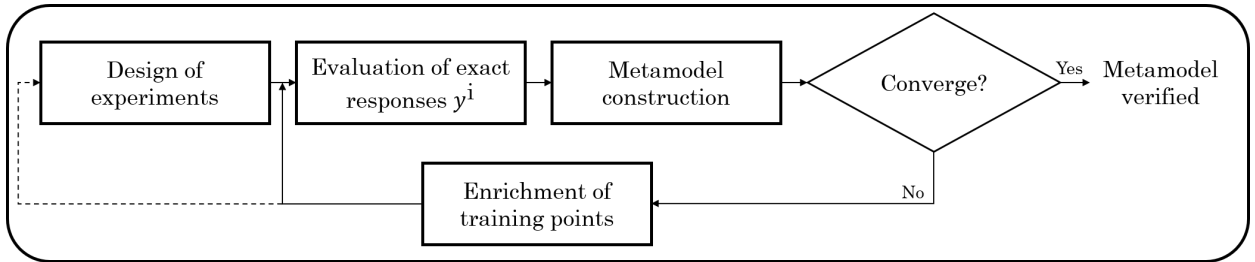

Figure 1: Surrogate modeling algorithm flowchart

153 The flowchart of the surrogate model process is presented in figure 1. Its implementation  
 154 is a multi-step process. Forrester et al. [23] present some used techniques to solve this  
 155 problem. First, Design Of Experiments (DOE) are applied by the surrogate modelling  
 156 approach. Particularly, Latin Hypercube Sampling (LHS) [36] is used in order to repeat  
 157 sampling in the design space. Kriging approach is then applied to represent the sampled  
 158 data. Accordingly, surrogate model can replace the original analysis code during the RBDO  
 159 procedure.

### 160 3.2. Kriging approach

161 Nowadays, Kriging method is widely used as surrogate approach. In fact, it is characterized  
 162 by its high quality of approximation with a required robustness, compared to other methods.  
 163 Kriging method, also called Gaussian process modelling [37], consists of two nested functions:



164 a deterministic function  $K(x)$  and a Gaussian random function  $Z(x)$ .

165 It can be written as follow:

$$y(x) = K(x) + Z(x) \quad (14)$$

166  $K(x)$  is usually determined as :

$$K(x) = \sum_{i=1}^{p-1} \beta_i \mathbf{f}_i(x) \quad (15)$$

167 Here,  $\boldsymbol{\beta} = [\beta_0, \beta_1, \dots, \beta_{p-1}]^T$  and  $f(x) = [f_0(x), f_1(x), \dots, f_{p-1}(x)]^T$  present the regression  
168 coefficients vector and regression basis function vector respectively.

169  $Z(x)$  is a zero-mean stochastic process with a non-zero covariance given by:

$$\text{Cov}(Z(\mathbf{x}) - Z(\mathbf{x}')) = \sigma^2 R(\mathbf{x}, \mathbf{x}') \quad (16)$$

170 We note that  $\sigma^2$  is the variance of  $Z(x)$ ,  $\mathbf{x}$  and  $\mathbf{x}'$  are the estimated sampling points in  
171 the design space and  $R(\mathbf{x}, \mathbf{x}')$  is the correlation function. It is an  $m$ -dimensional correlation  
172 functions constructed from *one*-dimensional correlation ones and obtained using a product  
173 correlation rule. For  $m$  design variables, the correlation function is defined by:

$$R(\mathbf{x}, \mathbf{x}') = \prod_{i=1}^m R(x_i, x'_i) \quad (17)$$

174 As mentioned in [38], exponential functions (equation (18)) and the Gaussian correlation  
175 functions (equation (19)) are the commonly used functions:

$$R(\mathbf{x}, \mathbf{x}') = \exp \left[ - \sum_{i=1}^m \theta_i |x_i - x'_i| \right] \quad (18)$$

$$R(\mathbf{x}, \mathbf{x}') = \exp \left[ - \sum_{i=1}^m \theta_i |x_i - x'_i|^2 \right] \quad (19)$$

177 With,  $\theta_i$  are the  $m$ -unknown parameters of  $R(\mathbf{x}, \mathbf{x}')$ . For any untried  $\mathbf{x}$ , the Kriging estimator  
178 [39] can be written as:

$$\hat{y}(\mathbf{x}) = \mathbf{r}^T(\mathbf{x}) \mathbf{R}^{-1}(\mathbf{y}_S - \mathbf{F}^T \boldsymbol{\beta}) + \mathbf{f}^T(\mathbf{x}) \boldsymbol{\beta} \quad (20)$$

179  $\hat{y}(\mathbf{x})$  is obtained by adding two functions. The first term consists in multiplying the untried  
180 sites correlation functions vector  $\mathbf{r}(\mathbf{x}) = [R(\mathbf{x}, \mathbf{x}^{(1)}), R(\mathbf{x}, \mathbf{x}^{(2)}), \dots, R(\mathbf{x}, \mathbf{x}^{(n)})]^T$  by the inverse  
181 of the correlation functions for the fitting sample matrix  $\mathbf{R}$  and the vector of residuals for  
182 all fitting points  $(\mathbf{y}_S - \mathbf{F}^T \boldsymbol{\beta})$ . Here,  $\mathbf{y}_S$  is the observed responses vector in the fitting sample  
183 and  $\mathbf{F}$  is the model matrix of variable parameters. It can be presented by:

$$\mathbf{F} = \begin{bmatrix} 1 & x_1^{(1)} & \dots & x_m^{(1)} & x_1^{(1)} x_2^{(1)} & \dots & x_{m-1}^{(1)} x_m^{(1)} & (x_1^{(1)})^2 & \dots & (x_m^{(1)})^2 \\ 1 & x_1^{(2)} & \dots & x_m^{(2)} & x_1^{(2)} x_2^{(2)} & \dots & x_{m-1}^{(2)} x_m^{(2)} & (x_1^{(2)})^2 & \dots & (x_m^{(2)})^2 \\ \vdots & \vdots & \ddots & \vdots & \vdots & \ddots & \vdots & \vdots & \ddots & \vdots \\ 1 & x_1^{(n)} & \dots & x_m^{(n)} & x_1^{(n)} x_2^{(n)} & \dots & x_{m-1}^{(n)} x_m^{(n)} & (x_1^{(n)})^2 & \dots & (x_m^{(n)})^2 \end{bmatrix} \quad (21)$$

184 The second term of (equation (20)) consists in multiplying the untired site regression basis  
 185 function  $\mathbf{f}^T(\mathbf{x})$  by the estimated regression coefficients vector  $\boldsymbol{\beta}$ .  
 186 Furthermore, the unknown model parameters  $\boldsymbol{\beta}$ ,  $\sigma^2$  and  $\boldsymbol{\theta}$  presented in equations (15), (16),  
 187 (18) and (19) respectively, needed to be determined to construct the Kriging predictor. To  
 188 this end, a methodology based on the Gaussian process framework of Kriging approach is  
 189 used. It consists in maximizing the likelihood function (equation (22)):

$$L(\boldsymbol{\beta}, \sigma^2, \boldsymbol{\theta}) = \frac{1}{\sqrt[2]{2\pi\sigma^2} \sqrt{|\mathbf{R}(\boldsymbol{\theta})|}} \exp \left[ -\frac{(\mathbf{y}_S - \mathbf{F}^T \boldsymbol{\beta})^T \mathbf{R}^{-1}(\boldsymbol{\theta})(\mathbf{y}_S - \mathbf{F}^T \boldsymbol{\beta})}{2\sigma^2} \right] \quad (22)$$

190 To simplify this function, the natural logarithm is then applied to the likelihood expression:

$$\ln(L) = -\frac{n}{2} \ln(2\pi) - \frac{n}{2} \ln(\sigma^2) - \frac{1}{2} \ln(|\mathbf{R}(\boldsymbol{\theta})|) - \frac{(\mathbf{y}_S - \mathbf{F}^T \boldsymbol{\beta})^T \mathbf{R}^{-1}(\boldsymbol{\theta})(\mathbf{y}_S - \mathbf{F}^T \boldsymbol{\beta})}{2\sigma^2} \quad (23)$$

191 By canceling the derivative of equation (23) with respect to  $\sigma^2$  and  $\boldsymbol{\beta}$  we obtain the Maximum  
 192 Likelihood Estimates (MLEs)  $\hat{\boldsymbol{\beta}}$  and  $\hat{\sigma}^2$ :

$$\hat{\boldsymbol{\beta}} = (\mathbf{F}^T \mathbf{R}^{-1} \mathbf{F})^{-1} \mathbf{F}^T \mathbf{R}^{-1} \mathbf{y}_S, \quad (24)$$

193 and

$$\hat{\sigma}^2 = \frac{(\mathbf{y}_S - \mathbf{F}^T \hat{\boldsymbol{\beta}})^T \mathbf{R}^{-1}(\boldsymbol{\theta})(\mathbf{y}_S - \mathbf{F}^T \hat{\boldsymbol{\beta}})}{n} \quad (25)$$

194 The estimator  $\hat{\boldsymbol{\theta}}$  is obtained by solving the optimization problem of equation (26):

$$\begin{aligned} \max_{\boldsymbol{\theta}} \quad & L(\boldsymbol{\theta}) = -\frac{1}{2} [n(\ln(2\pi) + \ln(\hat{\sigma}^2)) + \ln(|\mathbf{R}|)] \\ \text{s.t.} \quad & \theta_i > 0, \quad i = 1, \dots, m \end{aligned} \quad (26)$$

195 After determining the estimator  $\hat{\boldsymbol{\theta}}$  by solving equation (26),  $\hat{\boldsymbol{\beta}}$  and  $\hat{\sigma}^2$  can be defined using  
 196 equations (24) and (25). Consequently, the prediction at any given point can be estimated  
 197 by referring to equation (20).

### 198 3.3. Metamodel validation

199 Referring to [40], the efficiency of the constructed surrogate model is influenced by the  
 200 quantity and quality of the input dataset.

#### 201 3.3.1. Error measures

202 To examine the efficiency of the constructed metamodel, the most simple way is to verify  
 203 its residual errors. It consists in determining the difference between predicted response  $\hat{y}^{(i)}$   
 204 and the original one  $y^{(i)}$ . Smaller residual error means grater estimator efficiency.

205 The most used error indicators of such a surrogate model are:

206

207 The Maximum Absolute Error (MAE):

$$208 \quad MAE = \max |y^{(i)} - \hat{y}^{(i)}|, \quad i = 1, 2, \dots, n_t \quad (27)$$

209 \*\* The Relative Mean Error (RME):

$$210 \quad RME = \frac{1}{n_t} \sum_{i=1}^{n_t} \left| \frac{y^{(i)} - \hat{y}^{(i)}}{y^{(i)}} \right| \quad (28)$$

211 \*\*\* The Root Mean Squared Error (RMSE):

$$212 \quad RMSE = \sqrt{\frac{1}{n_t} \sum_{i=1}^{n_t} (y^{(i)} - \hat{y}^{(i)})^2} \quad (29)$$

213 where  $n_t$  is the sampling point number used to evaluate the error measures.

### 214 3.3.2. Cross validation

215 The Cross-Validation (CV) is another error indicator which we can verify the accuracy of  
 216 a surrogate model [41]. In CV, we define two type of samples data: training points responses  
 217  $y^{(i)}$  and test points  $\hat{y}_{-i}^{(i)}$  used to check its performances. It presents the prediction at  $\mathbf{x}^{(i)}$   
 218 using the surrogate model constructed from all sampling points except  $(\mathbf{x}^{(i)}, y^{(i)})$  [42]. The  
 219 Mean Squares Error (generalized error) for 'leave-one-out CV' can then be defined as:

$$MSE_{CV} = \frac{1}{n} \sum_{i=1}^n \left( y^{(i)} - \hat{y}_{-i}^{(i)} \right)^2 \quad (30)$$

## 220 4. Multi-objective optimization study

### 221 4.1. Deterministic Multi-Objective Optimization problem (DMOO)

222 Let's consider  $M$  objective functions  $f_m(x)$  to minimize. A DMOO approach is then  
 223 required to minimize these functions considering geometrical, physical and functional constraints.  
 224 Equation (31) can be then written as follow:

$$\begin{aligned} \min_x \quad & f_m(x), \quad m = 1, \dots, M \\ \text{s.t.} \quad & g_k(x) \leq 0, \quad k = 1, \dots, K \\ & h_j(x) = 0, \quad j = 1, \dots, J \\ & lb \leq x \leq ub \end{aligned} \quad (31)$$

225 Different from the mono-objective optimization, objective functions constitute a multi-  
 226 dimensional space in the multi-objective optimization, called the *objective function space*,  
 227 as well as the variable space used in all optimization problems. Figure 2 illustrates the  
 228 transition from the design variable space to the objective function space. Furthermore, for  
 229 each solution  $x$ , there is a point in the objective space, denoted by  $(f_1, f_2, \dots, f_M)^T$ .

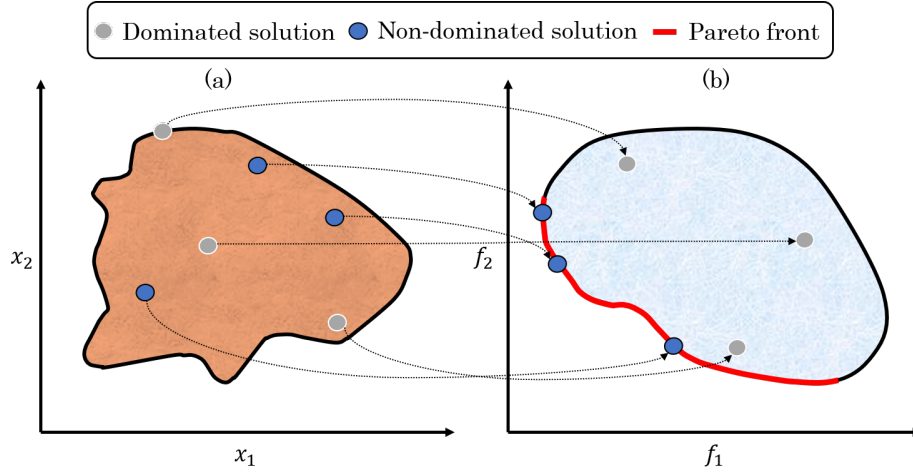

Figure 2: Transition from physical space (a) to objective space (b)

230 The DMOO approach aims to determine the optimal solution by choosing between a  
 231 set of obtaining points on the Pareto front, using a higher-level qualitative considerations.  
 232 Since, Evolutionary Multi-objective Optimization (EMO) approaches leads to find a set of  
 233 non-dominated solutions by making each population of solutions in each iteration intuitive  
 234 [43]. Figure 3 presents the EMO procedure for multi-objective optimization problems. It is  
 235 based on two steps:

- 236 • Step1: consists in finding closest multiple non-dominated points to the Pareto-optimal  
 237 front, with a wide trade-off among the objectives.
- 238 • Step2: consists in choosing the optimal point using higher-level information.

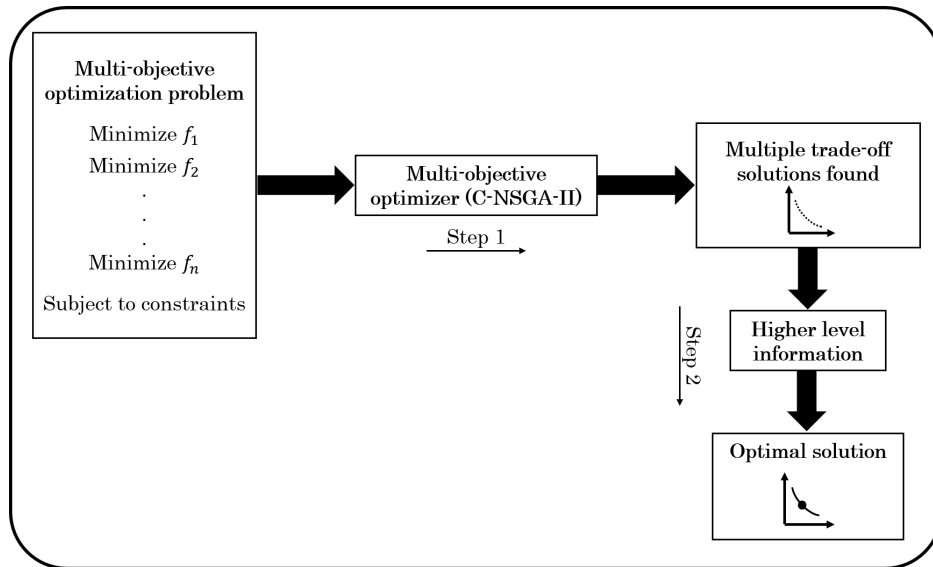

Figure 3: Flowchart of evolutionary multi-objective optimization procedure

239 *4.2. Multi-objective reliability based-design optimization (MORBDO)*

240 Comparing with the DMOO, the MORBDO aims to find the best compromise between  
 241 cost and reliability, taking into account design uncertainties. It can be mathematically  
 242 presented by [44, 45]:

$$\begin{aligned}
 & \min_x f_m(x), \quad m = 1, \dots, M \\
 & \text{s.t.} \quad P_r[G_k(x, y) \leq 0] \leq P_k^T, \quad k = 1, \dots, K \\
 & \quad \quad h_j(x) \leq 0, \quad j = 1, \dots, J
 \end{aligned} \tag{32}$$

243  $x$  and  $y$  are deterministic and random variables respectively.  $P_r[\cdot]$  presents the probability  
 244 operator and  $P_k^T$  is the target failure probability.  $h_j(x)$  and  $G_i(x, y)$  are respectively the  
 245 deterministic and the probabilistic constraints.

246  
 247 Dammak and El Hami [30] propose an efficient multi-objective optimization approach  
 248 called MORBDO-HM. This method is based on the classical hybrid method proposed in  
 249 [16, 17, 19]. The MORBDO-HM problem can be then described by:

$$\begin{aligned}
 & \min_{x,y} F_m(x, y) = f_m(x) \times d_\beta(x, y), \quad m = 1, \dots, M \\
 & \text{s.t.} \quad G(x, y) \leq 0 \\
 & \quad \quad g_k(x, y) \leq 0, \quad k = 1, \dots, K \\
 & \quad \quad d_\beta(x, y) \geq \beta_t
 \end{aligned} \tag{33}$$

250 It can be noted that  $d_\beta$  is the distance between the most probable failure point and the  
 251 optimal solution. It presents the reliability level and should be higher than the target  
 252 reliability level  $\beta_t$ . It has been proved in [30] that, MORBDO-HM has efficiently provided  
 253 an optimal solution where both physical and reliability constraints are respected. However,  
 254 the optimization problem becomes more complex and it may converge to a non-feasible  
 255 solution. To overcome this issue, an efficient method called MORBDO-RHM is proposed.  
 256 The basic idea of this method is based on adding a new constraint to the optimization  
 257 algorithm. The aim of this is to force the optimization problem to find the optimal point  
 258 where both physical and reliability constraints are respected. Mathematically, it is defined  
 259 as:

$$\begin{aligned}
 & \min_{x,y} F(x, y) = f_m(x) \times d_\beta(x, y) \quad m = 1, \dots, M \\
 & \text{s.t.} \quad G(x, y) \leq 0 \\
 & \quad \quad g_k(x) \leq 0, \quad k = 1, \dots, K \\
 & \quad \quad \beta(x, u) \geq \beta_t \\
 & \quad \quad lb \leq x \leq ub \\
 & \quad \quad f_m(x) \geq f_m(y)
 \end{aligned} \tag{34}$$

260 **5. Numerical analysis**

261 *5.1. Description of the numerical model*

262 Figure 4 presents a three-dimensional model of the studied cooling system. It is composed  
263 by an aluminum heat sink which contains a  $11 \times 12$  round pin fin matrix. Note that aluminum  
264 presents a high thermal conductivity as well as a lower mass (lower density). The dimensional  
265 details of the heat sink design are shown in figure 4.

266 The choice of this numerical configuration is based on an experimental study presented  
267 in [7]. The aim of this study is to propose a new methodology that leads to determine  
268 numerically an optimal design. To this end, firstly, this configuration needs to be validated  
269 with experimental data. Recently, several studies have been reported using metal-fins and  
270 metal-foam [46, 47]. However, the use of these configurations is limited to some specific  
271 applications and they are proportionally more expensive than classical ones.

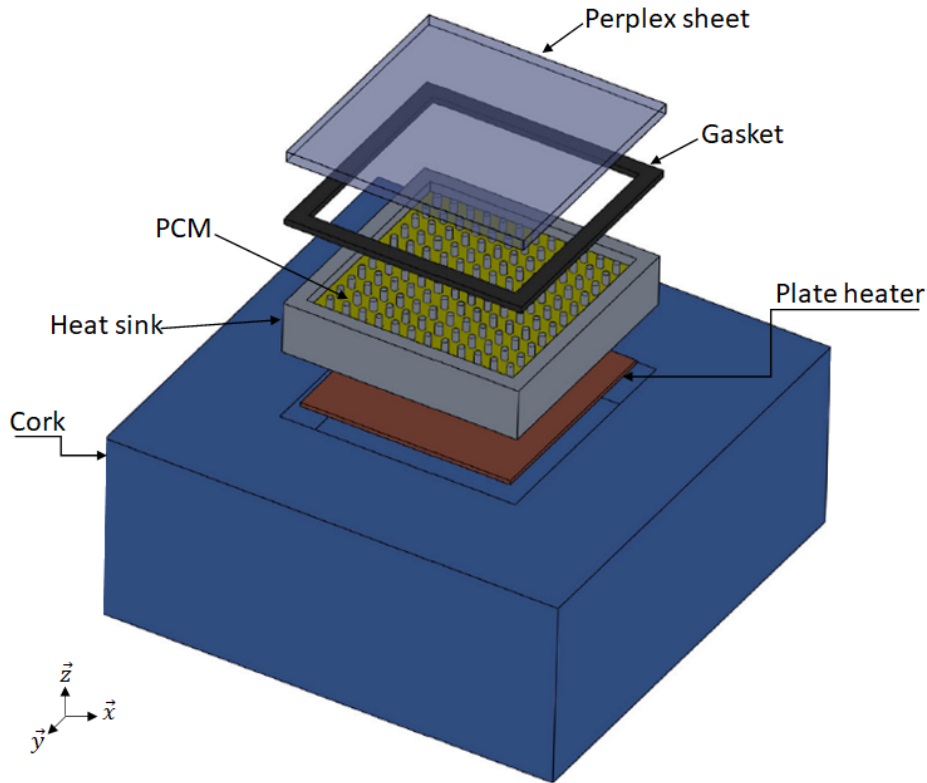

Figure 4: 3-D assembly of PCM-based heat sink

272 Experimentally, exterior walls of the heat sink are insulated with a rubber board, except  
273 the upper surface. The insulator presents a low thermal conductivity in order to minimize  
274 thermal losses and its properties are mentioned in table 2.

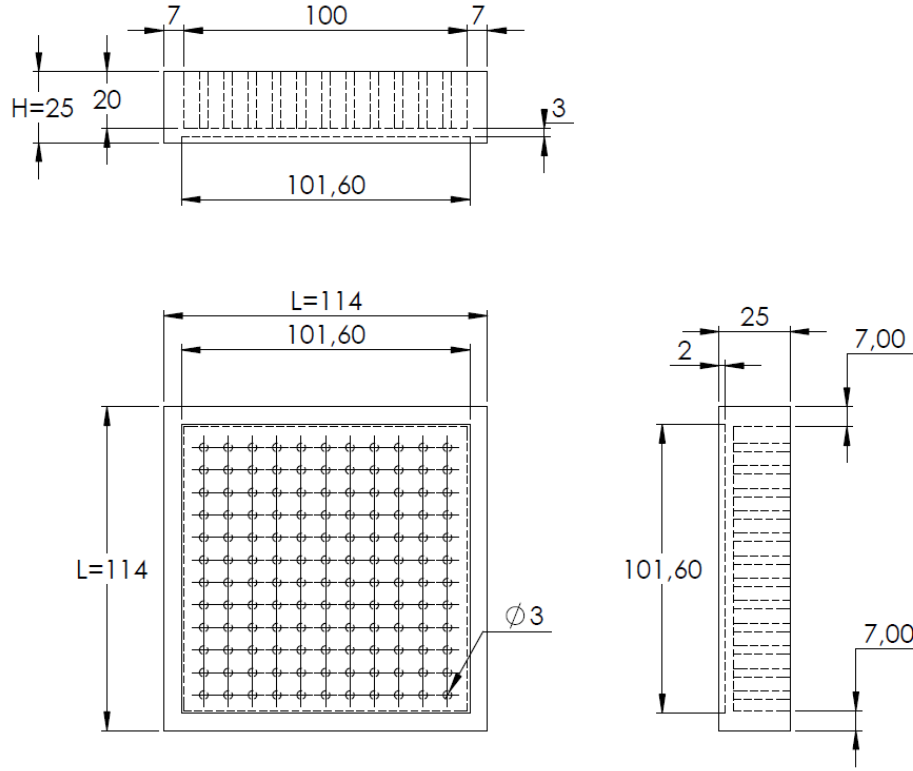

Figure 5: 2-D projections of 3mm round pin heat sink.

275 To control the liquid and solid fractions of PCM, the top surface is covered using silicon  
 276 gasket and Perspex sheet. Note that these parts are not considered in the proposed numerical  
 277 model.

278 The 3D numerical model is studied to compare the trends observed in the experimental  
 279 results [7]. A uniform heat flux is supplied from the heat source to the bottom surface of the  
 280 heat sink. It is transmitted then to the PCM, heat sink fins and finally to end walls. It can  
 281 be considered that the model does not take into account marginal effects such as natural  
 282 convection within melted PCM, and the volume changes in PCM after phase transition.  
 283 All required material dimensions and thermo-physical properties of the studied system are  
 284 available respectively in table 2 and table 3.

Table 2: Dimensions of required materials

Material	Used materials	Dimensions
1	Perspex sheet	$115 \times 115 \times 5 \text{ mm}^3$
2	Silicon rubber gasket	$115 \times 115 \times 5 \text{ mm}^3$ (with a cut out of $114 \times 114$ )
3	Rubber pad for heat sink	$220 \times 220 \times 25 \text{ mm}^3$ (with a cut out of $114 \times 114$ )
4	Rubber pad for heat sink bottom	$220 \times 220 \times 65 \text{ mm}^3$
5	Plate heater	$101.6 \times 101.6 \times 2 \text{ mm}^3$

Table 3: Thermo-physical properties of each material

Material	Thermal conductivity ( $W/m.K$ )	Specific heat ( $kJ/kgK$ )	Latent heat ( $kJ/kg$ )	Solidification point ( $^{\circ}C$ )	Melting point ( $^{\circ}C$ )	Density ( $kg/m^3$ )
Aluminum	201	0.9	-	-	606.4	2700
Paraffin Wax	0.212(s) 0.167(l)	2.8(s)	173.6	56	58	880(s) 790(l)
Rubber Pad	0.043	1.23	-	-	-	2500

285 *5.2. Boundary conditions*

286 A Finite Element (FE) computing software ANSYS Mechanical APDL is used to investigate  
287 the performance of the round pin fin heat sink filled with PCM.

288 A constant heat flux ( $Q=2800 W/m^2$ ) is applied to mimic the heat source at the HS bottom  
289 (presented by the red plate in figure 4). The charging phase is established for  $90min$  and it  
290 is performed at room temperature of  $18^{\circ}C$ .

291  
292 The "enthalpy-porosity" approach is adopted in the PCM-based heat sink to investigate  
293 the effect of the transition phase. In this numerical investigation, several hypotheses are  
294 considered:

- 295 • The HS material is homogeneous and isotropic .
- 296 • A local thermal equilibrium between fins and liquid PCM is considered.
- 297 • Whatever the phase and the temperature, the thermo-physical properties of PCM and  
298 fins are considered constant .
- 299 • The radiative heat transfer is also neglected.

300 Natural convection is applied on exterior areas of the insulator. To deal with governing  
301 equations, initial conditions as well as applied boundary conditions are:

- 302 • Initial conditions:

303  $t=0, T=T_{amb} = 18^{\circ}C, \xi = 0.$

304 Otherwise, at  $t=0$ , global model is maintained at room conditions and the proposed  
305 PCM is totally in the solid phase.

- 306 • Heat flux applied at the HS base:

307 
$$-\lambda \left. \frac{\partial T}{\partial x} \right|_{\substack{x = 6.2 \rightarrow 107.8 \\ y = 6.2 \rightarrow 107.8 \\ z = 2}} = -\lambda \left. \frac{\partial T}{\partial y} \right|_{\substack{x = 6.2 \rightarrow 107.8 \\ y = 6.2 \rightarrow 107.8 \\ z = 2}} = Q$$

308 *5.3. Preliminary results and discussion*

309 Figure 6 shows the mesh of the global studied numerical design. It is divided into 39240  
310 8-Node tetrahedral elements. Each element has eight nodes with a single degree of freedom,



311 temperature, at each node. It can be noted that a mesh refining is applied on the contact  
 312 surfaces of HS and PCM to give a better result.

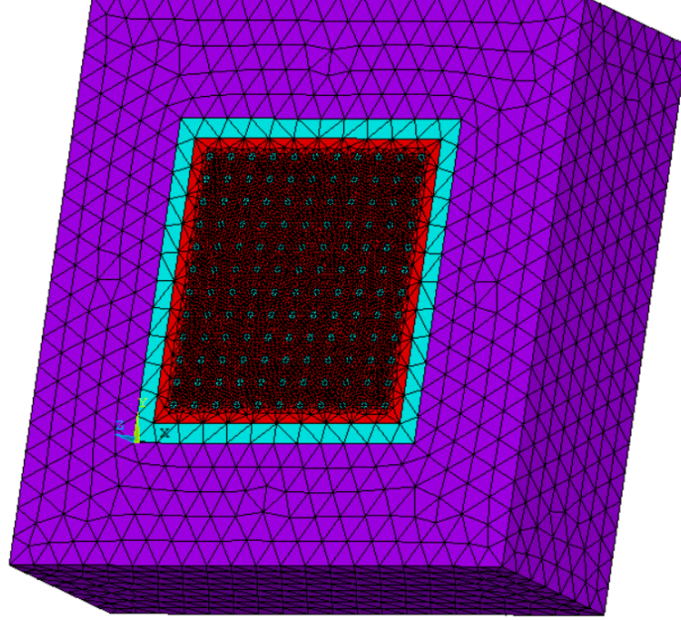

Figure 6: Mesh of studied model

313 Five different mesh sizes are investigated. The total computing time and the maximum  
 314 reached temperature  $T_{max}$  convergency are presented in [table 4](#).

Table 4: Mesh convergency study

Number of elements	36240	38001	39240	85756	141367
Simulation time ( <i>min</i> )	11.55	12.7	12.87	27.5	85.15
$T_{max}$ ( $^{\circ}C$ )	75.76	80.34	82.57	82.67	82.68

315 According to [table 3](#), the mesh configuration with 39240 elements is chosen to compromise  
 316 between cost and accuracy. In fact, the configuration with 141367 elements presents almost  
 317 the same maximum reached temperature with a higher computing time comparing with  
 318 39240 elements configuration. [Figure 7](#) presents the temperature-time profile at the HS  
 319 base for 3 *mm* pin fin heat sink configuration. Note that blue and red curves correspond  
 320 respectively to experimental and numerical results during the charging phase under  $Q= 2800$   
 321  $W/m^2$ .

322  
 323 For the heating phase, the temperature variation profile can be discretized into three  
 324 different regions:

- 325 • Solid region:  
 326 Initially, the temperature increases in a linear way from the ambient temperature  
 327  $T_{amb}=18^{\circ}C$  to the solidification temperature of PCM  $T_s=56^{\circ}C$ .

- 328 • Liquid region:
- 329 In this region, all the quantities of PCM inside enclosures will be totally melted. The
- 330 temperature increases, until 90 *min*.
  
- 331 • Latent heating region:
- 332 It can be seen that, for both numerical and experimental simulations, the increase
- 333 of the temperature has been significantly delayed due to the use of PCM. In fact,
- 334 benefiting from PCM thermo-physical properties, the energy generated by the input
- 335 source is stored by the PCM and causes its transition from the solid phase to liquid
- 336 phase.

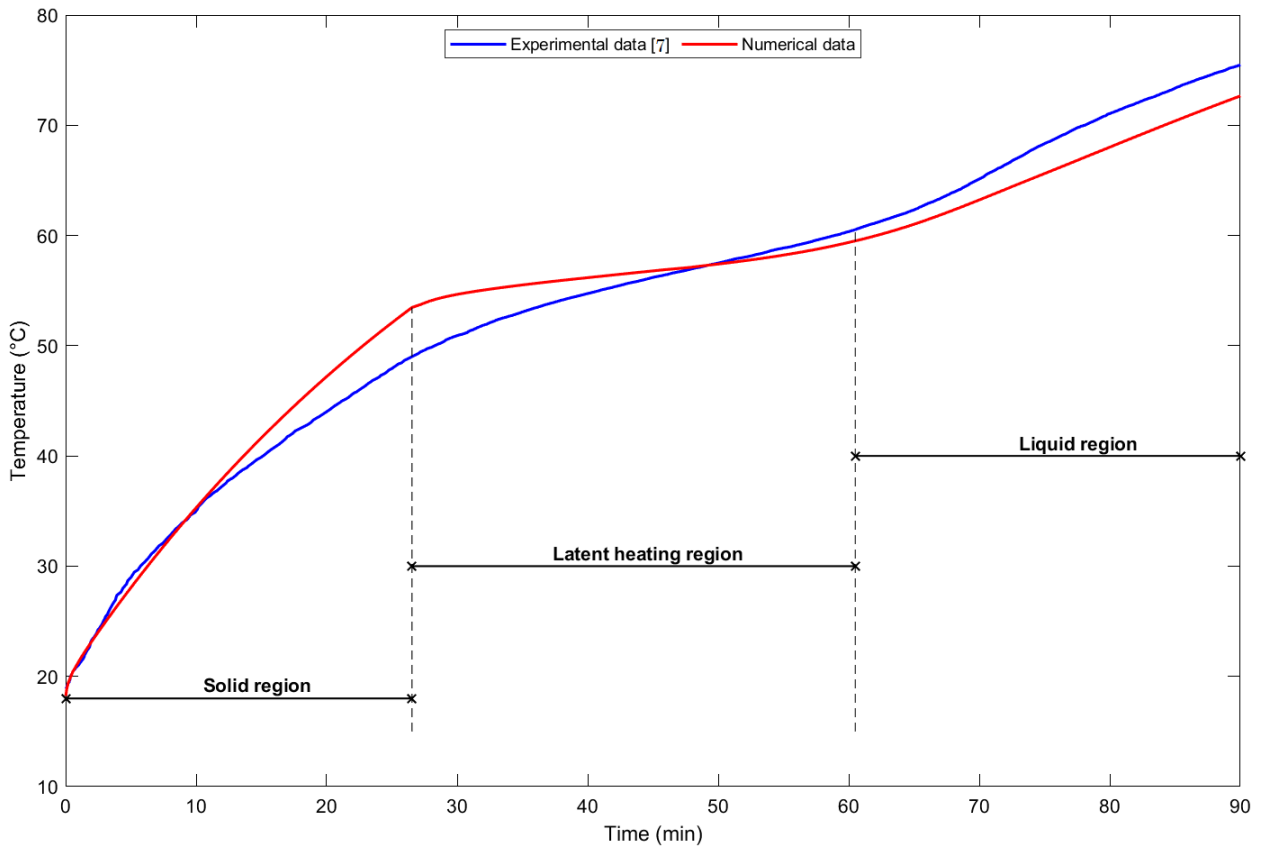

Figure 7: Temperature-time profile at the HS base under  $Q = 2800 \text{ W/m}^2$ .

337 It can be observed that numerical data compare reasonably well with the experimental  
 338 results found by Arshad et al. [7]. Hence, the coupled RBDO-metamodels problem can be  
 339 then proceeded. The design parameters considered in this study are supposed a random  
 340 probabilistic one which their characteristics are specified in table 5. We note that L and  
 341 H are respectively the length and the height of the HS and  $\phi$  is the pin-fin diameter (see  
 342 figure 5).

343

344 In a mono-objective RBDO method, the aim is to minimize one objective function  
345 subject to physical and reliability constraint. For a PCM-based cooling system problem,  
346 the objective function is generally chosen as its total volume, considering the maximum  
347 reached temperature  $T_{max}$ . However, obtained optimal design may present several issues  
348 in term of heat dissipation for the discharging phase related to greater designs [11]. To  
349 overcome this problem, minimizing cooling time must be considered. We note by  $t_f$  the  
350 final time to reach 25°C for the discharging phase. Furthermore, a 3D PCM-based heat  
351 sink model is expensive in term of computational time. Hence, the need to propose an  
352 original methodology of multiobjective RBDO coupled with surrogate model. Therefore,  
353 surrogate models are used to determine an approximation of  $T_{max}$  and  $t_f$  when changing  
354 design variables.

Table 5: Random variables properties

Variables	Symbol	Distribution type	Cov	Mean value	Lower bound ( <i>lb</i> )	Upper bound ( <i>ub</i> )
Length ( <i>mm</i> )	$L$	Normal	0.1	114	110	125
Height ( <i>mm</i> )	$H$	Normal	0.1	25	15	30
Pin fin diameter ( <i>mm</i> )	$\phi$	Normal	0.1	3	2	4

#### 355 5.4. Surrogate model results: Kriging approach accuracy

356 Meta-model approaches are applied to build estimations of the finite element simulation  
357 and determine the link between input parameters and their responses. The maximum  
358 reached temperature at the base of PCM-based round pin-fin heat sink is determined using  
359 Kriging surrogate models (equation (14)). To develop the Kriging meta-model, the Matlab  
360 toolbox package *Design and Analysis of Computer Experiments* (DACE) [48] is used. A  
361 second order polynomial global trend function and exponential correlation function are  
362 applied. Training data presented in (table 5) are then considered as the input of the FE  
363 analysis. The efficiency of the Kriging surrogate model is validated using error measures  
364 (equations (27) to (29)) as presented in table 6.

Table 6: Error measures of Kriging predictor

Error measures	20 LHS points		30 LHS points		50 LHS points	
	$T_{max}$	$t_f$	$T_{max}$	$t_f$	$T_{max}$	$t_f$
MAE	1.354	2.054	1.216	2.1587	0.4353	1.3895
RME	1.046e-03	0.0032	8.1313e-04	0.0027	3.5979e-04	0.0017
RMSE	0.377	0.489	0.0905	0.7629	0.2531	0.3181

365 Training points number with LHS comparison is presented via the CV in figures 8 to 10  
366 for 20, 30 and 50 LHS points, respectively.  
367 It can be concluded that the Kriging model obtained by 50 LHS points gives an estimation  
368 of the original design with acceptable efficiency. In other words, the model validation using

369 the Kriging approach with 50 LHS points is more accurate than other configurations to  
 370 estimate the link between input variables and their responses.

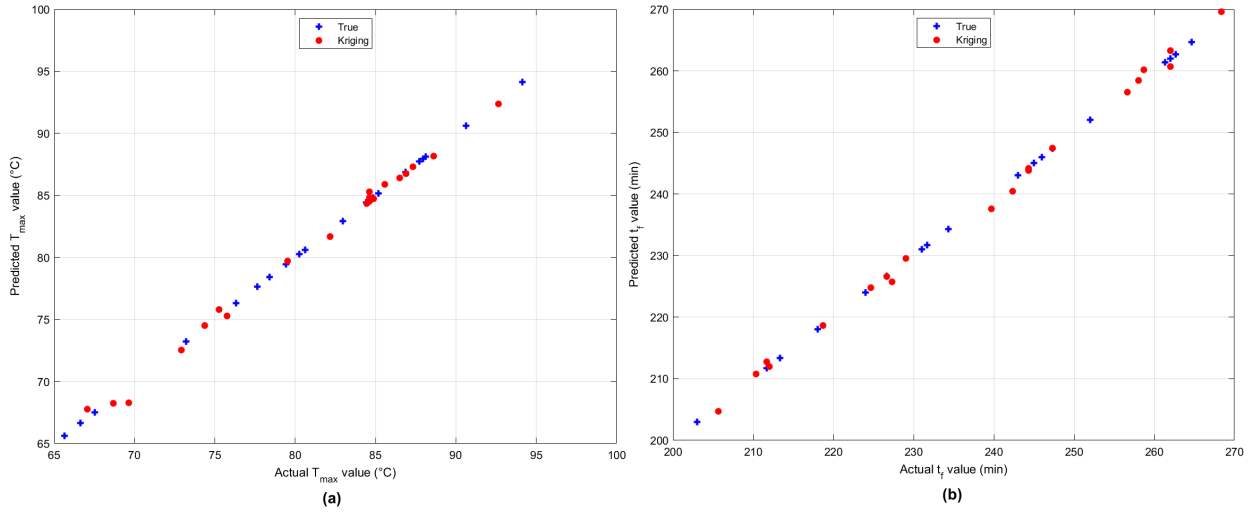

Figure 8: Cross-validation using Kriging predictor with 20 LHS points for (a)  $T_{max}$  and (b)  $t_f$

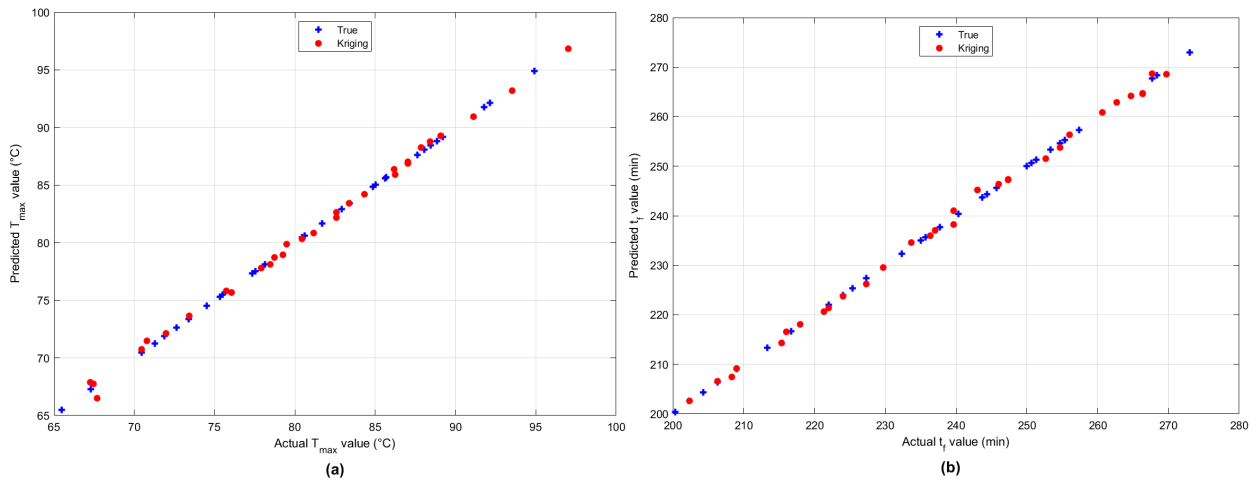

Figure 9: Cross-validation using Kriging predictor with 30 LHS points for (a)  $T_{max}$  and (b)  $t_f$

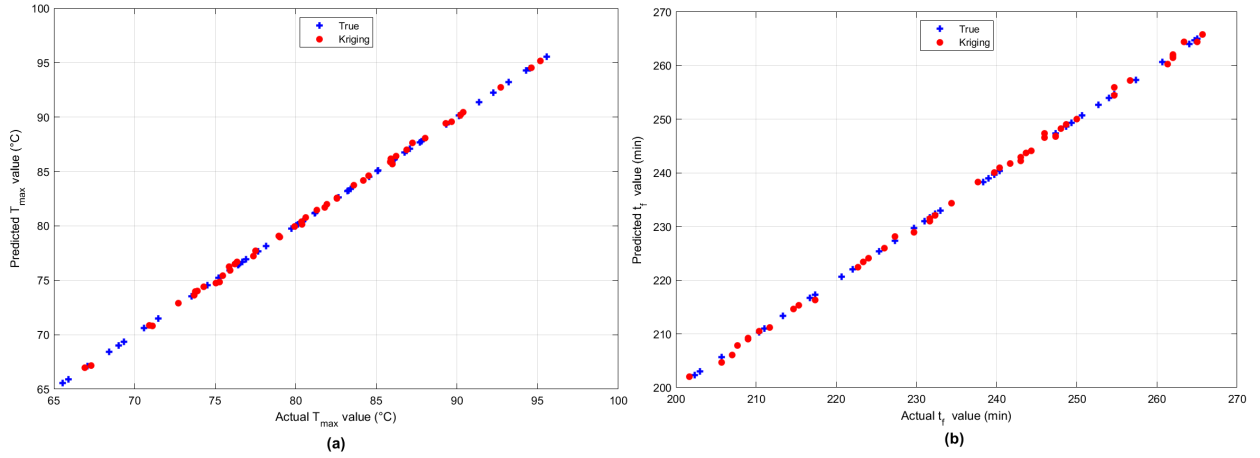

Figure 10: Cross-validation using Kriging predictor with 50 LHS points for (a)  $T_{max}$  and (b)  $t_f$

371 In the next section, Kriging model will be coupled with MORBDO simulation to analyze  
 372 optimization and reliability of the studied system.

373 *5.5. MORBDO for PCM-based heat sink*

374 In [49], authors develop the constrained non-dominated sorting genetic algorithm (C-  
 375 NSGA-II) to solve the optimization problem.

376 Pareto front using different populations sizes comparison is presented in figure 11. In  
 377 this paper, a maximum of 500 generations and a population size of 200 are used. This  
 378 configuration is used in order to determine if the spread in solutions is maintained.

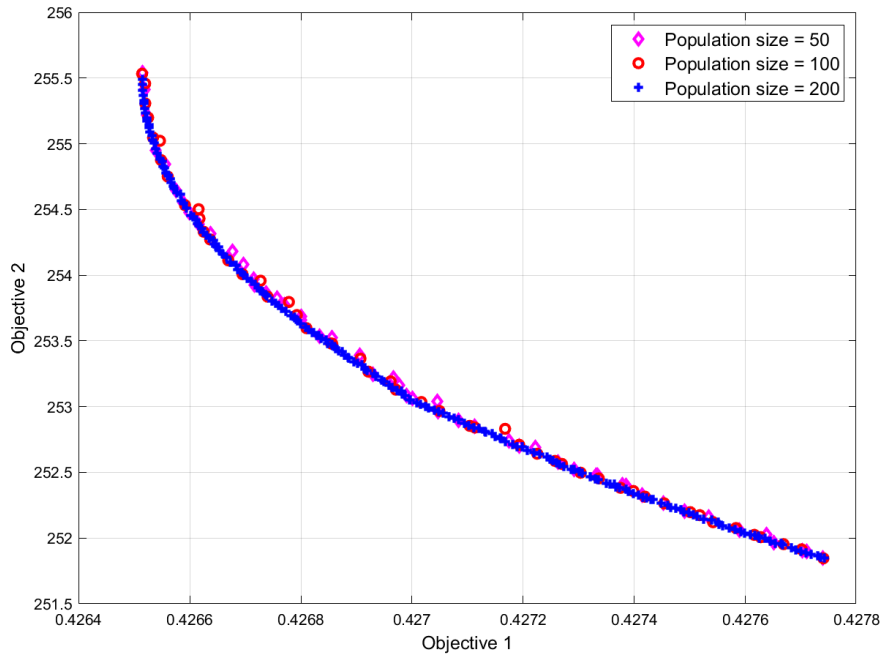

Figure 11: A comparison between different populations sizes

379 The optimization problem is based on minimizing the cooling system volume as well as the  
 380 final time ( $t_f$ ) taken for the discharging phase subject to the maximum reached temperature  
 381 ( $T_{max}$ ). Note that the critical temperature for the charging phase is about  $T_{crit} = 70^\circ C$ .  
 382 Generally, the target reliability level is supposed equal to:  $\beta_t=3$  which corresponds to a  
 383 failure probability about  $10^{-3}$ .

### 384 5.5.1. Results of DMOO

385 For the DMOO approach, the global safety factor  $S_g$  is chosen based on engineering  
 386 experience. Consequently, the optimal design temperature should be lower than the critical  
 387 values. Then, the DMOO problem is defined as:

$$\begin{aligned}
 & \min_x \{f_1(x) = V, f_2(x) = t_f\} \\
 & \text{s.t. } T_{max}(x) \leq \frac{T_{crit}}{S_g} \\
 & lb \leq x \leq ub
 \end{aligned} \tag{35}$$

388 Figure 12 presents the Pareto optimal front of DMOO. It provides, for design selection,  
 389 decision-makers with a set of solutions over the Pareto space. To select the best optimum,  
 390 called knee point [50], the Minimum Distance Selection Method (MDSM) [51] is considered  
 391 here as shown in figure 12. In a Pareto front, the knee point provides a good trade-off  
 392 between the objective functions. It presents the minimal distance from the utopia point.

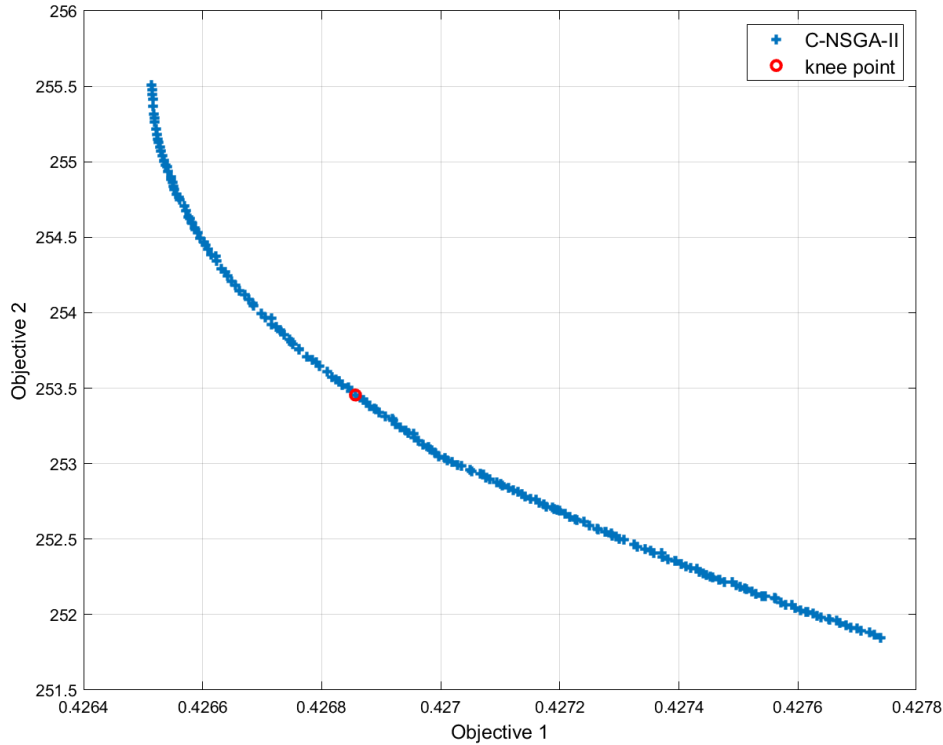

Figure 12: DMOO Pareto front

393 [Table 7](#) presents the deterministic MOO results. Referring to the baseline model, the  
394 DMOO approach presents an optimal design (the thermal constraint is verified), but its  
395 reliability level  $\beta$  is missing ( $\beta=1.85<3$ ). Therefore, to solve this issue, MORBDO methods  
396 are extremely recommended.

Table 7: DMOO results

Description		Design point	Optimal solution
		$y^*$	$x^*$
Design variables	$L$ (mm)	125	125
	$H$ (mm)	23.78	28.64
	$\phi$ (mm)	4	3.72
Objective function	$V$ (mm <sup>3</sup> )	3.51e+05	4.268e+05
	$t_f$ (min)	236.47	253.45
Thermal constraint	$T_{max}$ (°C)	70	63
Reliability value	$\beta$		1.85

### 397 5.5.2. Results of MORBDO

398 [Equation \(36\)](#) and [equation \(37\)](#) present respectively the MORBDO-HM and MORBDO-  
399 RHM optimization problem:

$$\begin{aligned}
& \min_{x,y} F(x, y) = [V(x), t_f(x)] \times d_\beta(x, y) \\
& \text{s.t. } T_{max}(y) \leq 70^\circ C \\
& \quad lb \leq x, y \leq ub \\
& \quad d_\beta(x, y) \geq \beta_t
\end{aligned} \tag{36}$$

$$\begin{aligned}
& \min_{x,y} F(x, y) = [V(x), t_f(x)] \times d_\beta(x, y) \\
& \text{s.t. } T_{max}(y) \leq 70^\circ C \\
& \quad lb \leq x, y \leq ub \\
& \quad d_\beta(x, y) \geq \beta_t \\
& \quad V(x) \geq V(y) \\
& \quad t_f(x) \geq t_f(y)
\end{aligned} \tag{37}$$

401 The corresponding Pareto front is illustrated in [figure 13](#) for both MORBDO-HM and  
402 MORBDO-RHM. MORBDO results are presented in [table 8](#). As well as DMOO, MORBDO  
403 results provide a set of optimal points over the Pareto space. Against DMOO, the reliability  
404 level with MORBDO is respected.

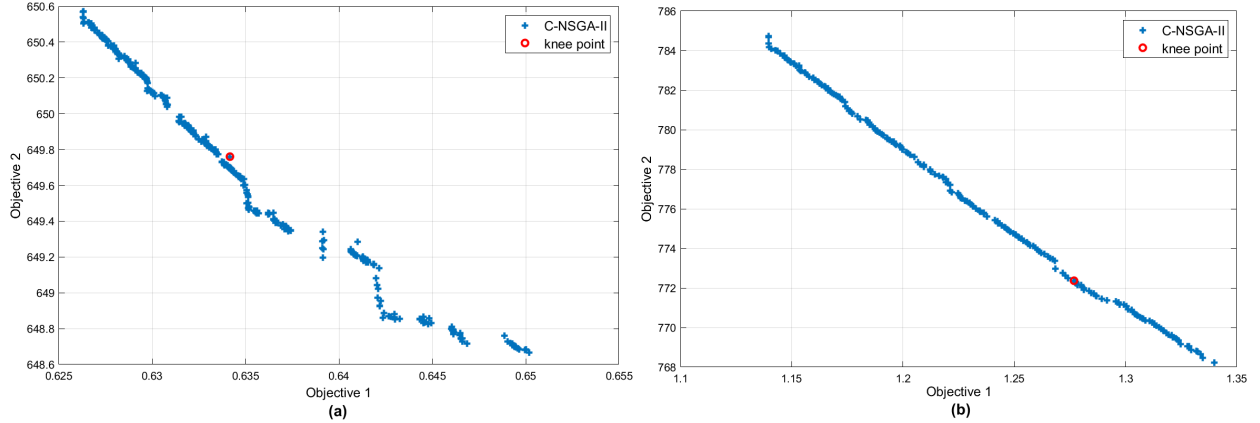

Figure 13: Pareto optimal front: (a) MORBDO-HM and (b) MORBDO-RHM

405 [Table 8](#) illustrated that MORBDO-HM gives an optimal resulted point within the failure  
 406 zone ( $T_{max} = 90.98^{\circ}C > 70^{\circ}C$ ). However, the MORBDO-RHM leads to obtain an optimal  
 407 configuration with respect of reliability constraint as well as thermal constraint, comparing  
 408 with DMOO and MORBDO-HM approaches.

Table 8: MORBDO results

Description	MORBDO-HM		MORBDO-RHM	
	Design point $y^*$	Optimal solution $x^*$	Design point $y^*$	Optimal solution $x^*$
Design variables	$L(mm)$	124.67	122.62	121.96
	$H(mm)$	24.04	18.89	30
	$\phi(mm)$	4	4	3.92
Objective functions	$V(mm^3)$	3.53e+05	2.11e+05	3.8279e+05
	$t_f(min)$	237.43	216.56	254.8
Thermal constraint	$T_{max}(^{\circ}C)$	70	90.98	69.86
Reliability value	$\beta$		3	3

409 The temperature-time profile, measured at the HS base, is presented in [figure 14](#), for  
 410 baseline design (red curve) and MORBDO-RHM design (blue curve). In this figure, charging  
 411 and discharging phases of cooling electronic devices are investigated.

412  
 413 As presented in figure 14 and table 8, the optimal design obtained by the MORBDO-  
 414 RHM approach verifies both thermal and reliability constraints. In fact, at  $t = 120min$ , the  
 415 maximum reached temperature  $T_{max}$  is lower than the critical temperature, which guarantees  
 416 a better performance of the electronic component. Moreover, reliability condition is verified  
 417 with this model. In fact, the reliability level of the optimal design is equal to the target  
 418 reliability level ( $\beta_{MORBDO-RHM} \geq \beta_t$ ). However, the baseline model does not respect this  
 419 condition and it may lead to an immediate failure of the electronic component. Furthermore,  
 420 for the optimal configuration, the latent heating phase period is more important than its  
 421 for baseline design throughout the charging phase. This can be explained by the fact that



422 the optimal configuration has the ability to store a large amount of thermal energy against  
 423 the baseline design. On the other hand, for the discharging phase, optimal design has the  
 424 ability to release the stored thermal energy in a minimal time compared with initial model.  
 425 In fact, PCM takes about  $40min$  to reach its solid states against over than  $55min$  for the  
 426 initial model.

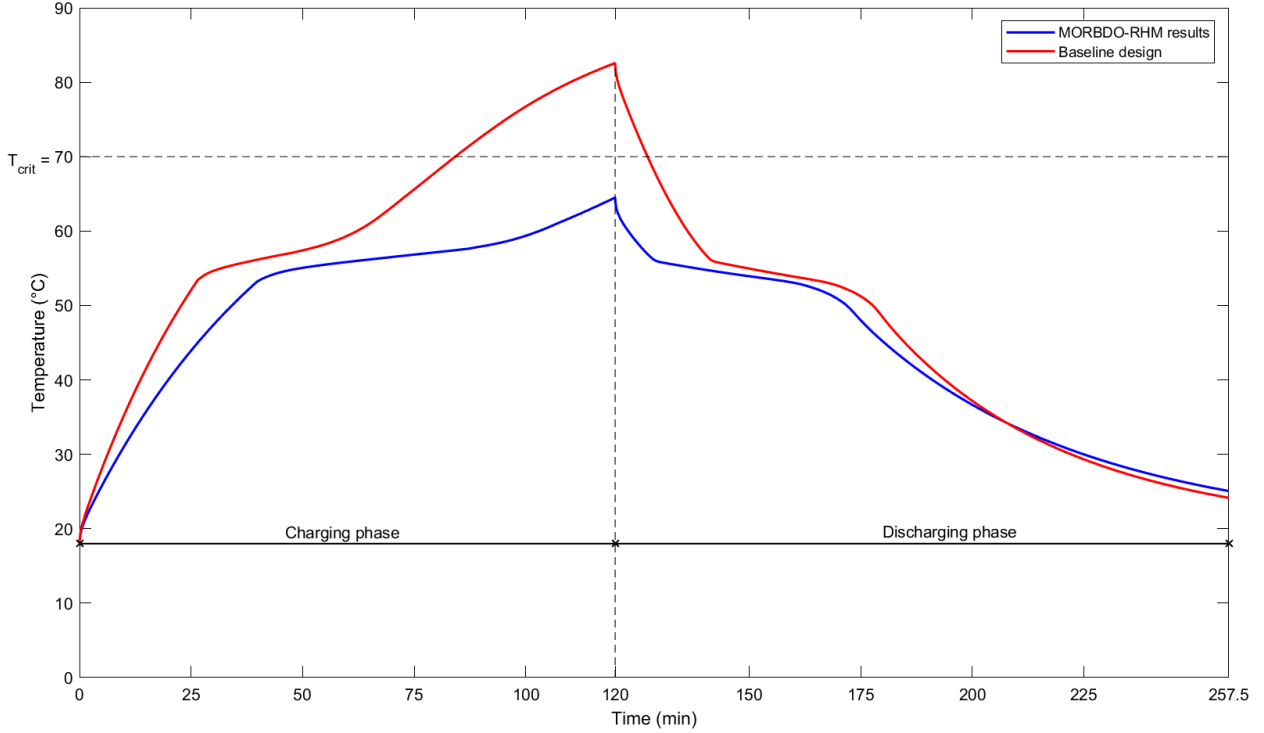

Figure 14: Temperature profile for baseline design and optimal design: charging and discharging phases.

## 427 6. Conclusion

428 This paper aims to propose an efficient method that leads to obtain an optimal configuration  
 429 of thermal management systems based on PCM technology which ensure a recommended  
 430 reliability level. In this work, a 3D transient numerical simulation of round pin-fin heat  
 431 sink fully filled with PCM is studied to investigate the thermal management behaviours for  
 432 passive cooling of electronic equipments.

433 Experimental results founded by Arshad et al. [7] are numerically validated for PCM  
 434 embedded in  $3mm$  round pin fin heat sink configuration subject to constant heat load  
 435 (about  $2800 W/m^2$ ).

436 To determine the relationship between the input and output variables, Kriging approach is  
 437 used in the construction of the surrogate model. The results of cross-validation and error  
 438 measures show that Kriging estimator with 50 LHS points gives an approximation of the  
 439 original design with great accuracy.

440 Although the DMOO approach is easy to apply and can ensure an optimum design, a  
 441 reliability level of thermal constraint is missed. Therefore, and in order to overcome this

442 issue, MORBDO methods are investigated for thermal management applications. MORBDO-  
443 RHM and MORBDO-HM approaches based on surrogate models are coupled with PCM-  
444 based heat sink design.

445  
446 The numerical study proves that the proposed MORBDO-RHM approach is more efficient  
447 and reliable comparing with MORBDO-HM approach. We conclude that, for thermal  
448 enhancer application using PCM-based HS, MORBDO-RHM approach leads to obtain an  
449 optimal design, where both thermal and reliability constraints are verified. The proposed  
450 methodology can be then applied to determine an optimal design of cooling systems that  
451 guarantees a higher performance of electronic components. Furthermore, it gives a better  
452 compromise between safety and cost, for both charging and discharging phases. An extension  
453 to other heat sink configurations such as square and triangular pin-fin heat sink needs to be  
454 studied and validated with experimental investigation.

## 455 References

- 456 [1] Ravi Kandasamy, Xiang-Qi Wang, and Arun S Mujumdar. Transient cooling of electronics using phase  
457 change material (pcm)-based heat sinks. *Applied thermal engineering*, 28(8-9):1047–1057, 2008.
- 458 [2] Akin Burak Etemoglu. A brief survey and economical analysis of air cooling for electronic equipments.  
459 *International communications in heat and mass transfer*, 34(1):103–113, 2007.
- 460 [3] Ronan Grimes, Ed Walsh, and Pat Walsh. Active cooling of a mobile phone handset. *Applied Thermal*  
461 *Engineering*, 30(16):2363–2369, 2010.
- 462 [4] Zhaoxia Luo, Hyejung Cho, Xiaobing Luo, and Kyung-il Cho. System thermal analysis for mobile  
463 phone. *Applied Thermal Engineering*, 28(14-15):1889–1895, 2008.
- 464 [5] Rajesh Baby and C Balaji. Thermal performance of a pcm heat sink under different heat loads: an  
465 experimental study. *International Journal of Thermal Sciences*, 79:240–249, 2014.
- 466 [6] Ibrahim Mjallal, Hussien Farhat, Mohammad Hammoud, Samer Ali, and Ibrahim Assi. Improving the  
467 cooling efficiency of heat sinks through the use of different types of phase change materials. *Technologies*,  
468 6(1):5, 2018.
- 469 [7] Adeel Arshad, Hafiz Muhammad Ali, Shahab Khushnood, and Mark Jabbal. Experimental investigation  
470 of pcm based round pin-fin heat sinks for thermal management of electronics: effect of pin-fin diameter.  
471 *International Journal of Heat and Mass Transfer*, 117:861–872, 2018.
- 472 [8] Jesto Thomas, PVSS Srivatsa, S Ramesh Krishnan, and Rajesh Baby. Thermal performance evaluation  
473 of a phase change material based heat sink: A numerical study. *Procedia technology*, 25:1182–1190,  
474 2016.
- 475 [9] Bessem Debich, Abdelkhalak El Hami, Ahmed Yaich, Wajih Gafsi, Lassaad Walha, and Mohamed  
476 Haddar. Design optimization of pcm-based finned heat sinks for mechatronic components: A numerical  
477 investigation and parametric study. *Journal of Energy Storage*, 32:101960, 2020.
- 478 [10] Abdelkhalak El Hami and Radi Bouchaib. *Uncertainty and optimization in structural mechanics*. Wiley  
479 Online Library, 2013.
- 480 [11] Bessem Debich, Abdelkhalak El Hami, Ahmed Yaich, Wajih Gafsi, Lassaad Walha, and Mohamed  
481 Haddar. An efficient reliability-based design optimization study for pcm-based heat-sink used for  
482 cooling electronic devices. *Mechanics of Advanced Materials and Structures*, pages 1–13, 2020.
- 483 [12] Bessem Debich, Ahmed Yaich, Abdelkhalak Elhami, Wajih Gafsi, Lassaad Walha, and Mohamed  
484 Haddar. Coupling pcm-based heat sinks finite elements model for mechatronic devices with design  
485 optimization procedure. In *2020 IEEE 6th International Conference on Optimization and Applications*  
486 *(ICOA)*, pages 1–4. IEEE, 2020.
- 487 [13] A Makhloufi, Y Aoues, and A El Hami. Reliability based design optimization of wire bonding in power  
488 microelectronic devices. *Microsystem Technologies*, 22(12):2737–2748, 2016.

- 489 [14] A El Hami and Bouchaib Radi. Comparison study of different reliability-based design optimization  
490 approaches. In *Advanced materials research*, volume 274, pages 113–121. Trans Tech Publ, 2011.
- 491 [15] A Abo Al-Kheer, Abdelkhalak El-Hami, Mohamed Ghias Kharmanda, and Abdel Mouem Mouazen.  
492 Reliability-based design for soil tillage machines. *Journal of Terramechanics*, 48(1):57–64, 2011.
- 493 [16] G Kharmanda, A Mohamed, and Maurice Lemaire. Efficient reliability-based design optimization using  
494 a hybrid space with application to finite element analysis. *Structural and Multidisciplinary Optimization*,  
495 24(3):233–245, 2002.
- 496 [17] A Yaich, G Kharmanda, Abdelkhalak El Hami, L Walha, and M Haddar. Reliability based design  
497 optimization for multiaxial fatigue damage analysis using robust hybrid method. *Journal of Mechanics*,  
498 34(5):551–566, 2018.
- 499 [18] K Dammak, A El Hami, S Koubaa, L Walha, and M Haddar. Reliability based design optimization  
500 of coupled acoustic-structure system using generalized polynomial chaos. *International Journal of*  
501 *Mechanical Sciences*, 134:75–84, 2017.
- 502 [19] Khalil Dammak, Ahmed Yaich, Abdelkhalak El Hami, Lassaad Walha, and Mohamed Haddar. An  
503 efficient optimization based on the robust hybrid method for the coupled acoustic–structural system.  
504 *Mechanics of Advanced Materials and Structures*, pages 1–11, 2018.
- 505 [20] Fatma Abid, Abdelkhalak El Hami, Tarek Merzouki, Lassaad Walha, and Mohamed Haddar. An  
506 approach for the reliability-based design optimization of shape memory alloy structure. *Mechanics*  
507 *Based Design of Structures and Machines*, pages 1–17, 2019.
- 508 [21] A Kamel, K Dammak, A El Hami, M Ben Jdidia, L Hammami, and M Haddar. A modified hybrid  
509 method for a reliability-based design optimization applied to an offshore wind turbine. *Mechanics of*  
510 *Advanced Materials and Structures*, pages 1–14, 2020.
- 511 [22] Ahmed Yaich, Fatma Abid, Tarek Merzouki, Abdelkhalak El Hami, Lassaad Walha, and Mohamed  
512 Haddar. A robust method for the reliability-based design optimization of shape memory alloy actuator.  
513 *Mechanics Based Design of Structures and Machines*, pages 1–19, 2021.
- 514 [23] Alexander Forrester, Andras Sobester, and Andy Keane. *Engineering design via surrogate modelling:  
515 a practical guide*. John Wiley & Sons, 2008.
- 516 [24] Achille Messac. *Optimization in practice with MATLAB®: for engineering students and professionals*.  
517 Cambridge University Press, 2015.
- 518 [25] A Ben Abdesslem and Abdelkhalak El-Hami. A probabilistic approach for optimising hydroformed  
519 structures using local surrogate models to control failures. *International Journal of Mechanical Sciences*,  
520 96:143–162, 2015.
- 521 [26] K Dammak, S Koubaa, A El Hami, L Walha, and M Haddar. Numerical modelling of vibro-acoustic  
522 problem in presence of uncertainty: Application to a vehicle cabin. *Applied Acoustics*, 144:113–123,  
523 2019.
- 524 [27] A Guerine, A El Hami, L Walha, T Fakhfakh, and M Haddar. A polynomial chaos method for the  
525 analysis of the dynamic behavior of uncertain gear friction system. *European Journal of Mechanics-*  
526 *A/Solids*, 59:76–84, 2016.
- 527 [28] Changwu Huang, Bouchaïb Radi, and Abdelkhalak El Hami. Uncertainty analysis of deep drawing using  
528 surrogate model based probabilistic method. *The International Journal of Advanced Manufacturing*  
529 *Technology*, 86(9-12):3229–3240, 2016.
- 530 [29] Fatma Abid, Khalil Dammak, Abdelkhalak El Hami, Tarek Merzouki, Hassen Trabelsi, Lassaad Walha,  
531 and Mohamed Haddar. Surrogate models for uncertainty analysis of micro-actuator. *Microsystem*  
532 *Technologies*, pages 1–12, 2020.
- 533 [30] Khalil Dammak and Abdelkhalak El Hami. Multi-objective reliability based design optimization  
534 using kriging surrogate model for cementless hip prosthesis. *Computer Methods in Biomechanics and*  
535 *Biomedical Engineering*, pages 1–14, 2020.
- 536 [31] Khalil Dammak and Abdelkhalak El Hami. Multi-objective reliability based design optimization of  
537 coupled acoustic-structural system. *Engineering Structures*, 197:109389, 2019.
- 538 [32] Yue-Tzu Yang and Yi-Hsien Wang. Numerical simulation of three-dimensional transient cooling  
539 application on a portable electronic device using phase change material. *International Journal of*

- 540 *Thermal Sciences*, 51:155 – 162, 2012.
- 541 [33] Yi-Hsien Wang and Yue-Tzu Yang. Three-dimensional transient cooling simulations of a portable  
542 electronic device using pcm (phase change materials) in multi-fin heat sink. *Energy*, 36(8):5214 – 5224,  
543 2011. PRES 2010.
- 544 [34] V. Shatikian, G. Ziskind, and R. Letan. Numerical investigation of a pcm-based heat sink with internal  
545 fins: Constant heat flux. *International Journal of Heat and Mass Transfer*, 51(5):1488 – 1493, 2008.
- 546 [35] K.C. Nayak, S.K. Saha, K. Srinivasan, and P. Dutta. A numerical model for heat sinks with phase  
547 change materials and thermal conductivity enhancers. *International Journal of Heat and Mass Transfer*,  
548 49(11):1833 – 1844, 2006.
- 549 [36] Michael D McKay, Richard J Beckman, and William J Conover. A comparison of three methods for  
550 selecting values of input variables in the analysis of output from a computer code. *Technometrics*,  
551 42(1):55–61, 2000.
- 552 [37] Christopher KI Williams and Carl Edward Rasmussen. *Gaussian processes for machine learning*,  
553 volume 2. MIT press Cambridge, MA, 2006.
- 554 [38] Tushar Goel, Willem Roux, and Nielen Stander. A topology optimization tool for ls-dyna users: Ls-  
555 opt/topology. In *7th european LS-Dyna conference*, pages 14–15, 2009.
- 556 [39] Bilal M Ayyub and George J Klir. *Uncertainty modeling and analysis in engineering and the sciences*.  
557 CRC Press, 2006.
- 558 [40] Ann-Britt Ryberg, Rebecka Domeij Bäckryd, and Larsgunnar Nilsson. *Metamodel-based*  
559 *multidisciplinary design optimization for automotive applications*. Linköping University Electronic  
560 Press, 2012.
- 561 [41] Martin Meckesheimer, Andrew J Booker, Russell R Barton, and Timothy W Simpson. Computationally  
562 inexpensive metamodel assessment strategies. *AIAA journal*, 40(10):2053–2060, 2002.
- 563 [42] Alexander IJ Forrester and Andy J Keane. Recent advances in surrogate-based optimization. *Progress*  
564 *in aerospace sciences*, 45(1-3):50–79, 2009.
- 565 [43] Kalyanmoy Deb. Multi-objective optimisation using evolutionary algorithms: an introduction. In  
566 *Multi-objective evolutionary optimisation for product design and manufacturing*, pages 3–34. Springer,  
567 2011.
- 568 [44] A Elhami, G Lallement, P Minotti, and S Cogan. Methods that combine finite group theory with  
569 component mode synthesis in the analysis of repetitive structures. *Computers & structures*, 48(6):975–  
570 982, 1993.
- 571 [45] Jianguang Fang, Yunkai Gao, Guangyong Sun, and Qing Li. Multiobjective reliability-based  
572 optimization for design of a vehicledoor. *Finite Elements in Analysis and Design*, 67:13–21, 2013.
- 573 [46] Mohamed Moussa El Idi and Mustapha Karkri. Heating and cooling conditions effects on the kinetic  
574 of phase change of pcm embedded in metal foam. *Case Studies in Thermal Engineering*, 21:100716,  
575 2020.
- 576 [47] Mohamed Moussa El Idi and Moustapha Karkri. Melting and solidification behavior of pcm embedded  
577 in metal foam. In *COMSOL CONFERENCE 2020 EUROPE*, 2020.
- 578 [48] Søren Nymand Lophaven, Hans Bruun Nielsen, Jacob Søndergaard, et al. *DACE: a Matlab kriging*  
579 *toolbox*, volume 2. Citeseer, 2002.
- 580 [49] Kalyanmoy Deb, Amrit Pratap, Sameer Agarwal, and TAMT Meyarivan. A fast and elitist  
581 multiobjective genetic algorithm: Nsga-ii. *IEEE transactions on evolutionary computation*, 6(2):182–  
582 197, 2002.
- 583 [50] Guangyong Sun, Guangyao Li, Shiwei Zhou, Hongzhou Li, Shujuan Hou, and Qing Li. Crashworthiness  
584 design of vehicle by using multiobjective robust optimization. *Structural and Multidisciplinary*  
585 *Optimization*, 44(1):99–110, 2011.
- 586 [51] Samer Barakat, Khaldoon Bani-Hani, and Mohammed Q Taha. Multi-objective reliability-based  
587 optimization of prestressed concrete beams. *Structural Safety*, 26(3):311–342, 2004.