



**HAL**  
open science

## **Life cycle assessment of wastewater source separation scenario: case study on a new district in Bordeaux, France**

Mathilde Besson, Jean-Christophe Aguas, Sylvaine Berger, Ligia Tiruta-Barna, Etienne Paul, Mathieu Spérandio

### ► **To cite this version:**

Mathilde Besson, Jean-Christophe Aguas, Sylvaine Berger, Ligia Tiruta-Barna, Etienne Paul, et al.. Life cycle assessment of wastewater source separation scenario: case study on a new district in Bordeaux, France. Second International Conference Water, Megacities and Global Change, Dec 2020, Paris, France. ⟨hal-03340985⟩

**HAL Id: hal-03340985**

**<https://hal.science/hal-03340985v1>**

Submitted on 10 Sep 2021

**HAL** is a multi-disciplinary open access archive for the deposit and dissemination of scientific research documents, whether they are published or not. The documents may come from teaching and research institutions in France or abroad, or from public or private research centers.

L'archive ouverte pluridisciplinaire **HAL**, est destinée au dépôt et à la diffusion de documents scientifiques de niveau recherche, publiés ou non, émanant des établissements d'enseignement et de recherche français ou étrangers, des laboratoires publics ou privés.



HAL Authorization

## **LIFE CYCLE ASSESSMENT OF WASTEWATER SOURCE SEPARATION SCENARIO: CASE STUDY ON A NEW DISTRICT IN BORDEAUX, FRANCE**

*Mathilde Besson<sup>1,2</sup>, Jean-Christophe Aguas<sup>2</sup>, Sylvaine Berger<sup>3</sup>, Ligia Tiruta-Barna<sup>1</sup>,  
Etienne Paul<sup>1</sup>, Mathieu Spérandio<sup>1</sup>*

### **KEYWORDS**

Wastewater, source separation, life cycle assessment, urine, blackwater, new district, case study

### **ABBREVIATIONS**

BOD<sub>5</sub>: biological oxygen demand at 5 days

BW: blackwater

BW-GW: blackwater – greywater

COD: chemical oxygen demand

LCA: Life Cycle Assessment

TMCS: transmembrane chemiosorption

TN: Total nitrogen

TP: Total phosphorus

U: Urine

UASB: upflow anaerobic sludge blanket

WRRF: Water resources recovery facility

WWTP: wastewater treatment plant

---

<sup>1</sup> TBI, Université de Toulouse, CNRS, INRAE, INSA, Toulouse, France

<sup>2</sup> ; Le Sommer Environnement, Paris, France

<sup>3</sup> SOLAGRO, Toulouse, France

---

## ABSTRACT

Source separation of urine and blackwater is an investigated solution to achieve wastewater resource recovery more efficiently than in the centralized and conventional wastewater treatment plant (WWTP). Several scenarios and treatment trains exist with more or less decentralized treatment. These scenarios need to be evaluated with life cycle assessment to highlight the advantages and the drawbacks of each one of them. District is the perfect scale to evaluate these scenarios as it is the scale of implementation of real pilot project. However it was not so frequently done. The tool developed in a previous study allows us to evaluate the case study of Belvédère in France. This district is under construction, and even if no source-separation is yet foreseen, it will be a good example of what can be achieved in a future French pilot project.

The study compares four different scenarios: two with urine source separation with a treatment at the WWTP or decentralized in the district. The two other scenarios consist on blackwater separation with a decentralized treatment of blackwater and also for the greywater in the last scenario. Process train consists on recovery of nitrogen, phosphorus and organic matter. Processes that already proved their efficiency at pilot scale have been chosen. Two different reference scenarios serve for the comparison: 1) the current wastewater treatment plant of Bordeaux which discharge the effluent into a non-sensitive area; 2) the WWTP improved with a nitrogen recovery step in the sludge line.

Results show that source separation is indeed the only way to recover significant amount of nitrogen from the district even if the WWTP has a nitrogen recovery step. The higher nitrogen recovery efficiency from source separation scenarios is the reason why these scenarios have less impact on climate change than reference (at least 46 % decrease). Indeed it allows reducing the N<sub>2</sub>O direct emissions from biological treatment of nitrogen and, in the meantime, to avoid emissions from fertilizer production. Blackwater separation presents a decrease in climate change impact compared to reference. However it comes with higher energy consumption by a factor 2 for the scenario with centralized treatment of greywater, and by a factor 5 for the totally decentralized scenario. Vacuum sewer and greywater treatment with a membrane bioreactor are responsible for this increase. More investigations are needed to reduce these two contributors.

## 1 INTRODUCTION

Wastewater management is currently shifting to resource recovery and not only treatment for protection of the receiving water. However the current design of wastewater treatment make difficult large amount of nutrient recovery. Indeed the available processes need to be implemented in high concentrated stream, which can only be in the sludge line after anaerobic digestion. Therefore source separation systems are investigated to answer this issue. Indeed between 70 % and 80 % of total nitrogen and around 50 % of the phosphorus in wastewater come from urine (Larsen and Gujer, 1996) for only 1 % of the wastewater flowrate. Two major types of source separation are tested since the 90'. The first one is urine source separation where urine is collected by urine diverting toilets until storage tank and transported to treatment site by truck. The second approach is blackwater (wastewater from toilet) separation which is collected by vacuum toilet to avoid dilution by large amount of flush water. Vacuum sewer is mandatory to transport this highly concentrated stream. Treatment consists in most cases on an anaerobic digestion followed by recovery or elimination of nutrient. Blackwater separation allows separating the greywater which can be reused for water reclamation. Besides, several projects focus only on greywater reclamation especially in water scarce region (Al-Jayyousi, 2003, p.; Friedler et al., 2005). In parallel to real pilot plant implementation (Larsen et al., 2013; Skambraks et al., 2017), environmental assessment have been perform to evaluate the drawbacks and advantages of these systems. Most of them study large implementation of source separation at city scale (Bisinella de

Faria et al., 2015; Landry and Boyer, 2016; Meinzinger et al., 2010; Remy and Jekel, 2008; Thibodeau et al., 2014, 2014). A few studied the implementation at district scale (Besson et al., 2020; Igos et al., 2017; Oldenburg et al., 2007), even if it will be the scale of implementation for a certain period of time. Moreover all these system studies have been addressed in cases study around the globe (Canada, USA, Germany, and the Netherlands) but never in France.

This study aims to assess the implementation of source separation system in a case study in Bordeaux, France for a new district which is currently under construction and will be for the next 10 years. A life cycle assessment of the wastewater management system is performed following the methodology presented in (Besson et al., 2020).

## 2 METHODS

This study aims to evaluate several scenarios of source separation at the district scale for the case study of the Belvédère in Bordeaux, France. In a first part of this methodology, the scenarios are described. They have been chosen to be closed to the pilot projects implemented in real application. The evaluation of the scenarios is performed thank to the tool developed in (Besson et al., 2020). The tool allows modeling the sanitation system at the district scale with wastewater collection, transport and treatment. It also takes into account the effect on source separation on the centralized wastewater treatment plant. Several changes have been implemented to be adapted to the context of this case study. The present methodology describes, thus in a second part, the main hypothesis of the tool and the major changes regarding the context of the case study.

### 2.1 Belvedere district

The Belvedere is a new district in Bordeaux in the South West of France. The new Belvedere district is located on the right bank of the Garonne, on former railway and port wastelands, opposite the historic Bordeaux, classified as a UNESCO World Heritage Site. This construction program is being carried out jointly by Nexity, Altarea Cogedim and Pitch Promotion according to an overall project designed by the Dutch urban planning architects Güller + Güller.

On 9.3 ha of land, 3.9 ha is built with a mix of use between housing, offices, business and hotel. Part of the urban planning is not defined and thus only the first phases of the project have been studied. Indeed only 2.6 ha of building are considered (Figure 1) for 14 ha of floor surface distributed between:

- 84 000 m<sup>2</sup> of housing and hotels
- 5 000 m<sup>2</sup> of offices
- 93 000 m<sup>2</sup> of business

Knowing the typology of the apartment (number of room), an number of inhabitant have been estimated according to the data of French statistical institute INSEE published in (COSTIC, 2016). The number of person using hotel and senior resident has been established with an average occupancy rate of 62.5% (for hotel) and 1.2 people per room.

The number of employee is also an essential feature to evaluate the wastewater production. It has been considered a value of 13 m<sup>2</sup> per employee in office. The minimal value according to French norm is 10 m<sup>2</sup>/employee and 15 for noisy environment (AFNOR, 1998). For business place the number of employee has been established by considering 57 m<sup>2</sup>/employee according to average value for retail from (Kfoury and Trevien, 2017).

The Belvedere district is located close to the WWTP, less than 10 km away from Clos de Hilde WWTP by sewer network or truck. This WWTP is not in a sensitive area of discharge and no limitation on

nitrogen and phosphorus concentration is mandatory. The treatment consists on an enhanced primary clarifier to remove a large proportion of suspended solid and organic matter. Phosphorus is also removed in this step. Two types of biofilters are the second step of treatment: one for COD removal only, the other one with nitrification. The primary and secondary sludge is send to anaerobic digestion and the final sludge is dewatered and composted (Ministère de la transition écologique et solidaire, 2018).

Finally, the green space in the district represents around 2.8 ha and consists on green roof, and green space on the ground. The need of irrigation can be estimated to 3 L/m<sup>2</sup>/j from May to September (Le Prieuré, 2020).

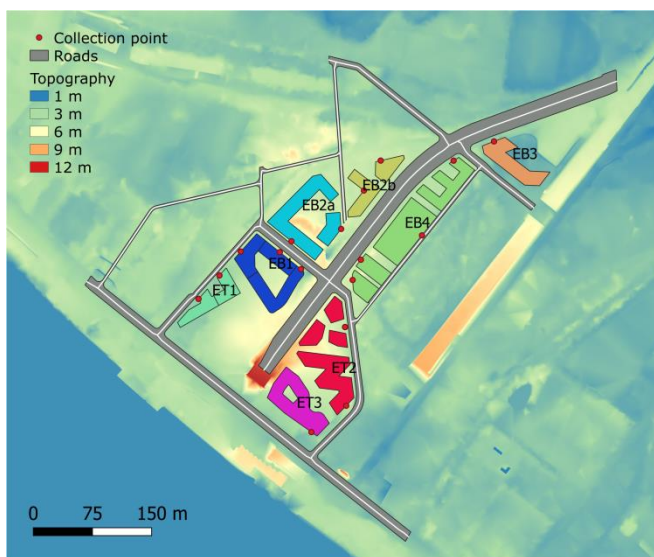

Figure 1: Belvédère district with the topography

## 2.2 Scenarios

Four scenarios of source separation have been analyzed (Figure 2)

In the first two scenarios, the urine is collected separately and treated in the centralized WWTP (U-Cent) or in a decentralized treatment located in the district (U-Decent). In both cases urine is collected in tanks and then transported once a week by truck (10m<sup>3</sup> trucks, two rounds per weeks). Considering 3 L or 6 L toilet flushes, it is considered that only 0.2 L of every flush goes into the urine compartment and storage, while the remaining volume goes with feces. Finally only 80 % of urine is still separated which corresponds to the best performances observed in pilot project (data from (Jönsson et al., 1998) and (Peter-Fröhlich et al., 2007) respectively for Understeshöjden et Palsternackan projects in Sweden and SCST project in Germany). The remaining 20 % is transported with feces. This urine recovery rate is influenced by the design of the toilet which allows more or less urine retention but also the willingness of the user to facilitate the separation. Indeed, urine separation toilet still requires gents to sit down when urinating. In U-Decent, after treatment the remaining effluent is sent to the centralized treatment.

The two others scenarios concern the blackwater separation from the greywater. Blackwater is collected thanks to vacuum toilet (1.2 L per flush) and transported by vacuum sewer to a center location in the district for treatment. In the scenario BW, greywater and the remaining effluent from blackwater treatment are sent to the centralized treatment through a gravity sewer. Blackwater is treated by an upflow anaerobic sludge blanket reactor (UASB) to produced biogas blanket (UASB,

SRT = 75 d, T=25°C, 60 % of coming COD converting into biogas (de Graaff et al., 2010)) followed by a struvite precipitation (removal of 86 % of phosphate with a Mg/P molar ratio of 1.5 (de Graaff and van Hell, 2014)) and TMCS (T = 45°C, pH = 9.6, 90 % recovery of ammonia, 50 % heat recovery).

In the scenario BW-GW both streams are treated in the district. In this case a membrane bioreactor is used for the greywater treatment, in order to have a high enough effluent quality to reuse it for non-potable purpose.

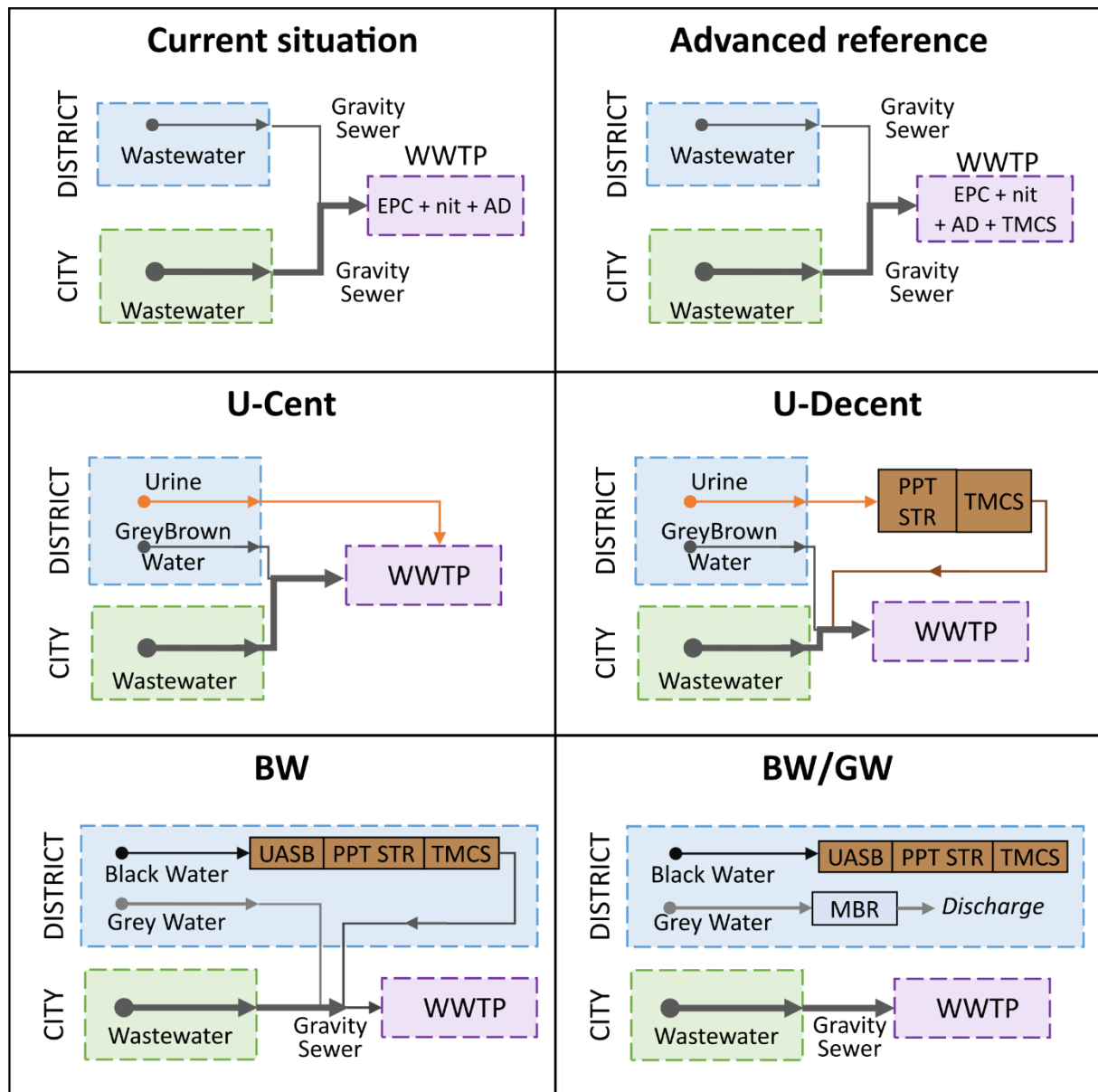

Figure 2: Studied scenarios EPC: Enhanced primary clarifier, AD: Anaerobic digester, PPTSTRU: Struvite precipitation, TMCS: transmembrane chemisorption, UASB: upflow active sludge blanket, MBR: membrane bioreactor.

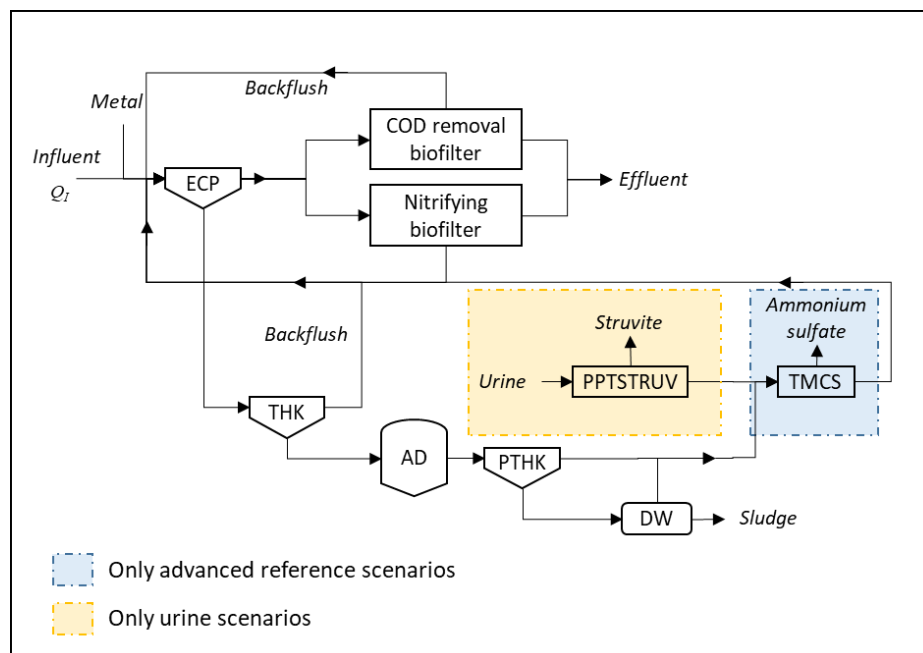

Figure 3: Wastewater treatment plant configuration

Two different WWTP have been used for this study Figure 3. The first one corresponds to the current WWTP of Clos de Hilde in Bordeaux already described. The second WWTP represents the transformation of Clos de Hilde WWTP to become a resource recovery facility. For this purpose, a TMCS unit is added on the supernatants of dewatering the sludge to recover nitrogen. Phosphorus is not recovered as it is difficult to recover it as it is bounded with metal ions from the primary clarifier step.

For all the scenario, the effluent composition is: 10 mgTSS/L, 25 mgN-NH<sub>4</sub>/L, 15 mgN-NO<sub>3</sub>/L, 0.5 mgP-PO<sub>4</sub>/L (Lepage and Etcheber, 2013). The WWTP has been modelled with the SUMO software v19.0.1 (Dynamita, 2019). Effluent composition has been controlled for each scenario with:

- A SRT for nitrified biofilter of 2.4 days and 0.7 days for only COD removal biofilter
- The pumped flow dividing the flow to treat between the two biofilters is control to achieve the ammonium content in the effluent.
- Caustic soda is added in the nitrified biofilter to keep a pH of 6.6
- The metal adjunction of the ECP is proportional of the flow to treat. (9.7E-7 with a concentration of 192.65 gFe/L)
- When TMCS is added, caustic soda adjunction is control by the pH of the influent (9.6)
- When struvite is added for the treatment of urine.

### 2.3 Description of the tool

The tool aims to model the buildings, the transport of wastewater with gravity or vacuum sewer or truck and treatment located in the district. For this purpose a geographical information system has been created and is used to design the transport. The smallest distance is assumed between each point of production and the collection point.

Gravity sewer is designed to achieve the transport of the peak flow by choosing the appropriate couple diameter / slope of the pipe according to (BERLAND, 2014; Bourrier, 2008;

Monfront, 2009; Okun et al., 2010). This couple needs to fulfil three self-cleansing conditions to avoid sedimentation in the pipes. Moreover, when depth is too high, assumed to be 4 meters in our model, a pumping station is placed and designed.

Vacuum sewer works with air transport instead of water transport as in gravity sewer. A lift in series allows maintaining the transport of the wastewater. The design rules of (Bowne et al., 1991; Islam, 2017; Roediger Vacuum, 2012; SQA E, 1994) have been followed with a minimum slope of 0.002 m/m and a maximum depth of 1.5m below surface. The pressure drop is calculated based on the recommendations of (Bowne et al., 1991; Islam, 2017; SQA E, 1994) for static pressure drop and of (Jinming and Jingxuan, 2006) for frictional pressure drop.

The topography is also taken into account for the design of the underground network. The digital elevation model of (Bordeaux Métropole, 2012) has been used with an accuracy of 15 meters.

## 2.4 LCA model and change

The function of the system, as defined in the LCA methodology, is *to collect and treat wastewater produced in the district while respecting the discharge limit of 25 mg-NNH<sub>4</sub>/L and 0.5 mg-PPO<sub>4</sub>/L, and this for one year*. The functional unit is thus 1 PE considering the EU normalized definition: 1 PE = 60 gDBO<sub>5</sub>/d.

Several changes have been made since the first version of the tool:

- Migration from Ecoinvent 2.6 to Ecoinvent 3.6 Market have been used when available (FR or RER or CH or GLO with this order of priority)
- N<sub>2</sub>O emissions are different regarding the biofilter: 0.017 gNN<sub>2</sub>O/gN entering the biofilter with nitrification and 0,0083 for the biofilter without nitrogen treatment (IPCC, 2019).
- French electricity mix
- Transport of by-products (compost, ammonium sulfate and struvite) is done by truck with 69% EURO VI, 27% EURO V and 4% EURO IV according to the French fleet average (Comité national routier, 2019)
- Heat at district is produced from an urban heat network alimented by 45% geothermal source at low temperature (55°C), 25% biomass combustion and 20% natural gas.
- Avoided process: tap water production from underground water with chemical treatment.
- The sludge is composted with gas emissions (0.73 gCH<sub>4</sub>/kgsludge treated, 0.16 gNH<sub>3</sub>/kgsludge, 0.04 gVOC/kgsludge (Maulini-Duran et al., 2013) and 0,6 gN<sub>2</sub>O/kg-dry waste and 2% of nitrogen in dry waste (IPCC, 2008)) and electricity need for aeration and mixing (90 kWh/Mg dry waste with bulk material (Brown et al., 2010) and a volumetric ratio of 1:3 for sludge and bulking agent and 42% of dry mass in the bulking agent (Maulini-Duran et al., 2013))

### 3 RESULTS

#### 3.1.1 DISTRICT CHARACTERISTICS

The Belvédère district produces 361.5 m<sup>3</sup>/d of wastewater in the reference scenario (Table 1). Urine diluted by toilet flush represents only a flowrate of 7.1 m<sup>3</sup>/d. Considering a transport by 10m<sup>3</sup> truck, 5 rounds per week are needed to collect urine (one per working days). The ratio of COD/N/P of wastewater in the reference scenario is around 56.9/6.5/1 where the average ratio is 68/5.6/1 (Pons et al., 2004). The difference highlight the high production from offices where less greywater is produced and thus less COD compared to the nutrients coming from human excreta. Indeed office wastewater corresponds to 33 % of the total wastewater flowrate but to 50 % of the nitrogen and 47 % of the phosphorus.

*Table 1: Flowrate and mass flow for the different streams to treat*

Streams	Scenario	Flowrate (m <sup>3</sup> /d)	COD (kg/d)	TN (kgN/d)	TP (kgP/d)
<b>Wastewater</b>	Reference	361.5	352.9	40.5	6.2
<b>Urine</b>	U-Decent U-Cent	7.1	29.4	25.1	2.2
<b>Brown Greywater</b>	U-Decent U-Cent	354.4	323.5	15.4	4.0
<b>Effluent from urine treatment</b>	U-Decent	7.1	0.1	6.1	0.4
<b>Blackwater</b>	BW BW-GW	25.8	204.0	36.9	4.7
<b>Effluent from BW treatment</b>	BW	23.6	0.1	10.6	0.9
<b>Greywater</b>	BW BW-GW	293.8	149.0	3.6	1.4

#### 3.1.2 MASS BALANCE

The current WWTP does not recover significantly the nitrogen, only 8 % is found in the sludge. Phosphorus is more recovered (59 %) since phosphate is precipitated in the EPC with the adjunction of coagulant and flocculation. The organic matter, thanks to the EPC, is well recovered with 48 % in the biogas and 21 % in the remaining sludge.

The advanced WWTP allows recovering more nitrogen (19 % with 10 % in the ammonium sulfate from TMCS process). The COD recovered in biogas also increases up to 54 % of the incoming COD. Indeed as less nitrogen entering the biofilters step, less COD need to be send to the nitrifying biofilter and more sludge is produced from the other biofilter.

### 3.2 LIFE CYCLE ASSESSMENT

#### 3.2.1 CUMULATIVE ENERGY CONSUMPTION

The impact category “cumulative energy consumption” allows analyzing the use of energy in the life cycle of the system from the different source of energy. Figure 4 presents in positive value the consumption of energy and in negative value the avoided production of energy.

The two scenarios of urine source separation and the reference show lower energy consumption with only fossil fuel consumption. This consumption is linked to construction of the infrastructure of the WWTP and sewer and the production of chemicals. However the two scenarios with black water separation present higher consumption due to nuclear energy consumption, linked to vacuum sewer electricity consumption and in the case of BW-GW scenario to greywater treatment.

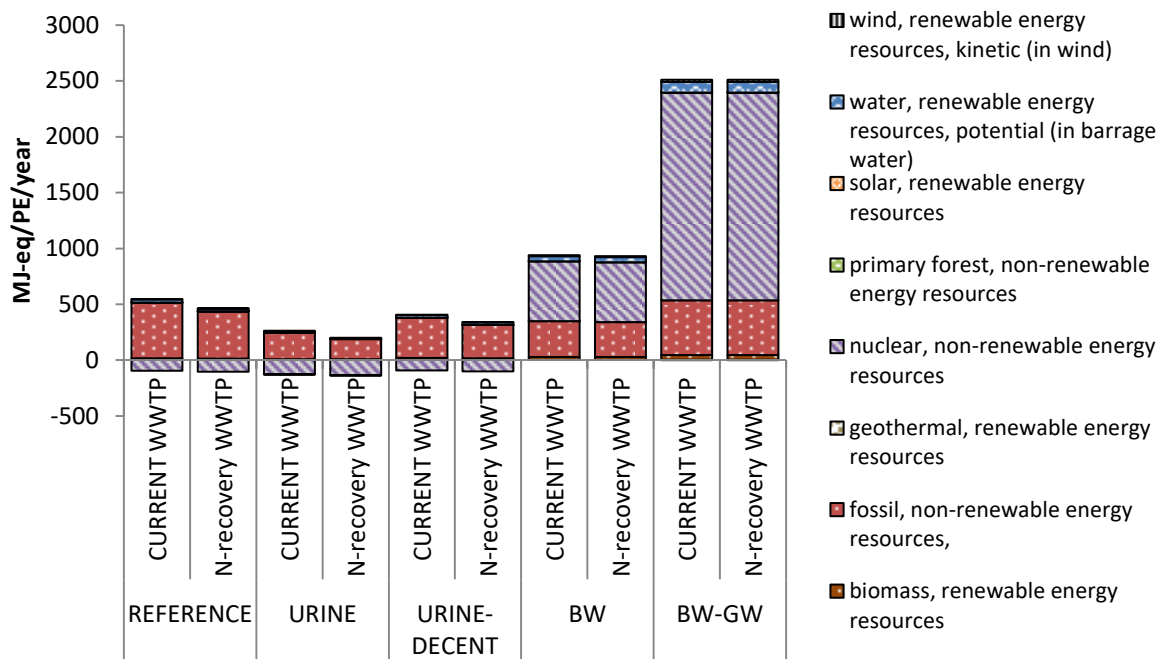

Figure 4: Cumulative energy demand for the scenarios with current WWTP and the WWTP with N-recovery step

The model predicts an energy consumption of the vacuum sewer of  $11.5 \text{ kWh}_{\text{elec}}/\text{m}^3_{\text{BW}}$  which is in the range of operational value reported in the pilot projects:  $5.6 \text{ kWh}/\text{m}^3$  in (de Graaff and van Hell, 2014) and from 13 to  $21 \text{ kWh}/\text{m}^3$  (Albold, n.d.; OtterWasser GmbH, 2009). But it represents 80 % of the electricity of the system in the BW scenario and 36 % for the BW-GW scenario which is not negligible.

If advanced WWTP with nitrogen recovery is implemented, a small decrease in cumulative energy demand is observed for Reference, Urine-Cent and Urine-Decent scenarios. It is link to a decrease in chemical use at the WWTP. Less nitrification is required as the nitrogen in the sludge is partially recover. Less caustic soda is needed in the nitrifying step.

### 3.2.2 CLIMATE CHANGE IMPACT

Regarding the climate change impact, this high energy consumption of BW and BW-GW scenarios, is not a predominant contributor. Indeed the French electricity mix is used with a large proportion of nuclear energy. Therefore all the alternative scenarios present an improved climate change impact. This reduction of the impact is feasible by:

- 1) the decrease in direct emission into air and especially nitrous oxide ( $\text{N}_2\text{O}$ )
- 2) the increase of avoided production of fertilizer

Thanks to a low impact on climate change of the energy consumption of MBR, the reuse of treated greywater compensate the emissions. However in this scenario, all the greywater is assumed to be reused, but flush water represent only 6 % of the treated greywater. Irrigation water demand in a first approach, can be estimated to  $84 \text{ m}^3/\text{d}$  during May to September and  $12\,850 \text{ m}^3/\text{year}$  which is

only 12 % of the annual average of treated greywater flowrate. If only these two reclamations are foreseen, the balance for BW-GW scenario will be 48.9 kgCO<sub>2-eq</sub>/PE/year against 34.6. Therefore, this scenario is still more efficient than the reference (97.6 kgCO<sub>2-eq</sub>/PE/year). In this first approach the energy consumption needed for the reused water sewer was not taken into account and should be to validate this decrease in impact.

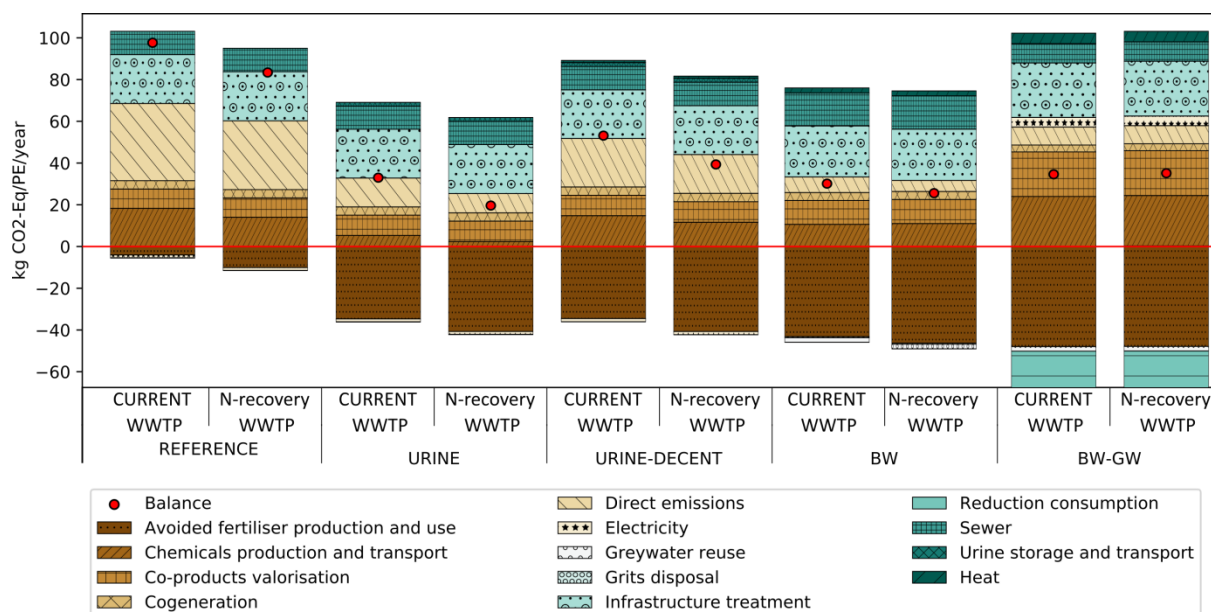

Figure 5: Comparison of climate change impact for the scenarios with current WWTP and the WWTP with N-recovery step

The shift from the current WWTP to the WWTP with N-recovery, decreases by 15 % the climate change impact of the reference. The benefit to have an N-recovery WWTP is the highest for U-Cent scenario. Indeed between current and N-recovery plant a decrease of 41 % is observed. Therefore, a process which can treat the urine and the effluent from sludge treatment is the best strategy.

## Conclusions

This first analysis shows that the implementation of source separation of urine or blackwater can be very interesting for the Belvédère district. A decrease of at least 46 % of climate change impact can be achieved with all the scenarios. The nitrogen recovery is the predominant factor explaining this decrease with lower emission of N<sub>2</sub>O with nitrogen separation and increase in avoided production of fertilizer. Greywater treatment allows water for non-potable use to be produced. Even if the gain linked to avoided production of tap water is not so significant, it can contribute to preserve the water resource.

The energy consumption of vacuum sewer and greywater treatment need, nevertheless, a closer attention, in order to avoid a significant increase in the bill for collectivity and users but also to achieve sobriety. Vacuum sewer could operate will lower energy consumption and optimization on the location of the vacuum plant needs to be performed to limit the pressure loss. Other greywater treatment could

also be investigated with lower energy consumption and in a more extensive way. Several projects attempts to implement nature based solution (like reed bed filter, known also as living machine or wetland system as in San Francisco (SFPUC, 2018).

## References

- AFNOR, 1998. Norme NF X35-102: Conception ergonomique des espaces de travail en bureaux.
- Albold, A., n.d. Flintenbreite.
- Al-Jayyousi, O.R., 2003. Greywater reuse: towards sustainable water management. Desalination, Joint EDS, WSTA and IWA conference on Desalination and the Environment Fresh Water for All UN International Year of Fresh Water 2003 156, 181–192. [https://doi.org/10.1016/S0011-9164\(03\)00340-0](https://doi.org/10.1016/S0011-9164(03)00340-0)
- BERLAND, J.-M., 2014. Assainissement des agglomérations. Techniques de l'ingénieur Gestion de l'eau base documentaire : TIB234DUO.
- Besson, M., Berger, S., Tiruta-Barna, L., Paul, E., Spérandio, M., 2020. Environmental assessment of urine, black and grey water separation for resource recovery in a new district compared to centralized WRRF. *Journal of Cleaner Production* In preparation.
- Bisinella de Faria, A.B., Spérandio, M., Ahmadi, A., Tiruta-Barna, L., 2015. Evaluation of new alternatives in wastewater treatment plants based on dynamic modelling and life cycle assessment (DM-LCA). *Water Research* 84, 99–111. <https://doi.org/10.1016/j.watres.2015.06.048>
- Bordeaux Métropole, 2012. Modèle numérique de terrain 2012.
- Bourrier, R., 2008. Les réseaux d'assainissement - calculs, applications, perspectives (5e éd.). Lavoisier.
- Bowne, W.C., Naret, R.C., Otis, R.J., 1991. Manual - alternative wastewater collection systems (Manual No. EPA/625/1-91/024). U.S. Environmental Protection Agency, Office of research and development, National risk management research laboratory., Cincinnati, Ohio, USA.
- Brown, S., Beecher, N., Carpenter, A., 2010. Calculator Tool for Determining Greenhouse Gas Emissions for Biosolids Processing and End Use. *Environ. Sci. Technol.* 44, 9509–9515. <https://doi.org/10.1021/es101210k>
- Comité national routier, 2019. Enquêt longue distance 2018. L'observatoire économique du transport routier de marchandises.
- COSTIC, 2016. Les besoins d'eau chaude sanitaire en habitat individuel et collectif (Guide technique). ADEME, France.
- de Graaff, M.S., Temmink, H., Zeeman, G., Buisman, C.J.N., 2010. Anaerobic Treatment of Concentrated Black Water in a UASB Reactor at a Short HRT. *Water* 2, 101–119. <https://doi.org/10.3390/w2010101>
- de Graaff, R., van Hell, A.J., 2014. Nieuwe Sanitatie Noorderhoek, Sneek deelonderzoeken (New Sanitation Noorderhoek, Sneek sub-studies) (No. 2014–48), STOWA. STOWA, Amersfoort - Netherlands.
- Dynamita, 2019. SUMO. URL <http://www.dynamita.com/> (accessed 4.1.16).
- Friedler, E., Kovalio, R., Galil, N.I., 2005. On-site greywater treatment and reuse in multi-storey buildings. *Water Sci. Technol.* 51, 187–194.
- Igos, E., Besson, M., Navarrete Gutiérrez, T., Bisinella de Faria, A.B., Benetto, E., Barna, L., Ahmadi, A., Spérandio, M., 2017. Assessment of environmental impacts and operational costs of the implementation of an innovative source-separated urine treatment. *Water Research* 126, 50–59. <https://doi.org/10.1016/j.watres.2017.09.016>
- IPCC, 2019. Wastewater treatment and discharge, in: 2019 Refinement to the 2006 IPCC Guidelines for National Greenhouse Gas Inventories. IPCC, Switzerland.

- 
- IPCC, 2008. 2006 IPCC Guidelines for National Greenhouse Gas Inventories – A primer, Prepared by the National Greenhouse Gas Inventories Programme, IGES, Japan.
- Islam, M.S., 2017. Comparative evaluation of vacuum sewer and gravity sewer systems. *International Journal of System Assurance Engineering and Management* 8, 37–53. <https://doi.org/10.1007/s13198-016-0518-z>
- Jönsson, H., Burström, A., Svensson, J., 1998. Mätning på två urinsorterande avloppssystem (Report No. 228). Uppsala.
- Kfoury, J., Trevien, C., 2017. Les points de vente du commerce de détail -. Insee Première 1668.
- Landry, K.A., Boyer, T.H., 2016. Life cycle assessment and costing of urine source separation: Focus on nonsteroidal anti-inflammatory drug removal. *Water Research* 105, 487–495. <https://doi.org/10.1016/j.watres.2016.09.024>
- Larsen, T.A., Gujer, W., 1996. Separate management of anthropogenic nutrient solutions (human urine). *Water Science and Technology* 34, 87–94.
- Larsen, T.A., Udert, K.M., Lienert, J. (Eds.), 2013. Source separation and decentralization for wastewater management. IWA Publ, London.
- Le Prieuré, 2020. Irrigation demand.
- Lepage, M., Etcheber, H., 2013. Etude intégrée de l'effet des apports amont et locaux sur le fonctionnement de la Garonne estuarienne (ETIAGE): Rapport année 3 Avril 2012 - Mars 2013 Addendum (report). irstea.
- Maulini-Duran, C., Artola, A., Font, X., Sánchez, A., 2013. A systematic study of the gaseous emissions from biosolids composting: Raw sludge versus anaerobically digested sludge. *Bioresource Technology* 147, 43–51. <https://doi.org/10.1016/j.biortech.2013.07.118>
- Meininger, F., Otterpohl, R., Londong, J., 2010. Resource efficiency of urban sanitation systems: a comparative assessment using material and energy flow analysis, *Hamburger Berichte zur Siedlungswasserwirtschaft. Ges. zur Förderung und Entwicklung der Umwelttechnologien an der Techn. Univ. Hamburg-Harburg, Hamburg*.
- Ministère de la transition écologique et solidaire, 2018. BEGLES (CLOS DE HILDE) [WWW Document]. Portail d'information sur l'assainissement communal. URL <http://assainissement.developpement-durable.gouv.fr/> (accessed 7.17.20).
- Monfront, L., 2009. Dimensionner les canalisations d'assainissement pour assurer leur performance hydraulique. (Sewer design to insure hydraulic performance) (Rapport Etude & Recherche No. 158.E–2), Les Editions du CERIB. CERIB, France.
- Okun, D.A., Wang, L.K., Shammas, N.K., 2010. *Water Supply and Distribution and Wastewater Collection*. John Wiley and Sons.
- Oldenburg, M., Peter-Fröhlich, A., Dlabacs, C., Pawlowski, L., Bonhomme, A., 2007. EU demonstration project for separate discharge and treatment of urine, faeces and greywater – Part II: Cost comparison of different sanitation systems. *Water Science & Technology* 56, 251. <https://doi.org/10.2166/wst.2007.578>
- OtterWasser GmbH, 2009. Ecological housing estate, Flintenbreite, Lübeck, Germany (Case study of sustainable sanitation projects), Sustainable Sanitation Alliance (SuSanA).
- Peter-Fröhlich, A., Bonhomme, A., Oldenburg, M., 2007. Sanitation concepts for separate treatment of urine, faeces and greywater (SCST) (Final report: EU-demonstration project No. Contract: LIFE03ENV/D000025). KompetenzZentrum Wasser Berlin gGmbH.
- Pons, M.-N., Spanjers, H., Baetens, D., Nowak, O., Gillot, S., Nouwen, J., Schuttinga, N., 2004. Wastewater characteristics in Europe - A survey. *European water management online* 4, 10 p.
- Remy, C., Jekel, M., 2008. Sustainable wastewater management: life cycle assessment of conventional and source-separating urban sanitation systems. *Water Science & Technology* 58, 1555. <https://doi.org/10.2166/wst.2008.533>
- Roediger Vacuum, 2012. *Vacuum Sewer Systems Construction Manual*. Pipe laying and installation of RoeVac® collection chambers and valves.

- SFPUC, 2018. San Francisco's Non-potable Water System Projects. San Francisco Public Utilities Commission.
- Skambraks, A.-K., Kjerstadius, H., Meier, M., Davidsson, Å., Wuttke, M., Giese, T., 2017. Source separation sewage systems as a trend in urban wastewater management: Drivers for the implementation of pilot areas in Northern Europe. *Sustainable Cities and Society* 28, 287–296. <https://doi.org/10.1016/j.scs.2016.09.013>
- SQAE, 1994. Assainissement des eaux usées dans les petites collectivités : techniques particulières de collecte des eaux usées. Volume 3 : Le réseau d'égouts sous vide. SQAE, Menviq, EAT Environnement.
- Thibodeau, C., Monette, F., Glaus, M., 2014. Comparison of development scenarios of a black water source-separation sanitation system using life cycle assessment and environmental life cycle costing. *Resources, Conservation and Recycling* 92, 38–54. <https://doi.org/10.1016/j.resconrec.2014.08.004>