



**HAL**  
open science

# Designing An Active Anti Roll Bar Control System For A Semi -Trailer

Duc Tien Bui, Olivier Sename, van Tan Vu

► **To cite this version:**

Duc Tien Bui, Olivier Sename, van Tan Vu. Designing An Active Anti Roll Bar Control System For A Semi -Trailer. ICMCE 2021 - 10th International Conference on Mechatronics and Control Engineering (ICMCE 2021), Jul 2021, Lisbon, Portugal. 10.1007/978-981-19-1540-6\_16 . hal-03300480

**HAL Id: hal-03300480**

**<https://hal.science/hal-03300480v1>**

Submitted on 27 Jul 2021

**HAL** is a multi-disciplinary open access archive for the deposit and dissemination of scientific research documents, whether they are published or not. The documents may come from teaching and research institutions in France or abroad, or from public or private research centers.

L'archive ouverte pluridisciplinaire **HAL**, est destinée au dépôt et à la diffusion de documents scientifiques de niveau recherche, publiés ou non, émanant des établissements d'enseignement et de recherche français ou étrangers, des laboratoires publics ou privés.

# Designing An Active Anti Roll Bar Control System For A Semi – Trailer

Duc Tien Bui<sup>1</sup>, Olivier Sename<sup>2</sup> and Van Tan Vu<sup>3</sup>

<sup>1</sup> Department of Automotive Engineering, Faculty of Mechanical Engineering, Thuyloi University, 175 Tay Son, Dong Da, Hanoi, Vietnam

<sup>2</sup> Univ. Grenoble Alpes, CNRS, Grenoble INP, GIPSA-Lab, 38000 Grenoble, Institute of Engineering Univ. Grenoble Alpes, France

<sup>3</sup> Department of Automotive Mechanical Engineering, Faculty of Mechanical Engineering, University of Transport and Communications, Hanoi, Vietnam  
buiductionien.ckoto@tlu.edu.vn

**Abstract.** Nowadays, tractor semi-trailer heavy vehicles are the most popular transport vehicle in the world because of their benefits. However, the traffic accidents related to these vehicles usually are serious consequences. The main reason causes these accidents is the loss stability of tractor semi-trailer heavy vehicles, particularly is the roll-over phenomenon of them. In order to improve the roll stability, most modern these vehicles are equipped a passive anti - roll bar system. However, the passive anti - roll bar does not meet the required stability when the vehicle is in emergencies. This paper investigates the influence of the suspension roll damping and roll stiffness parameters on the stability of the tractor semi-trailer and designs an active anti – roll bar control system for semi-trailer, by using Linear Quadratic Regulator (LQR) method. The obtained results show that these suspension parameters do not meet well for the vehicle roll stability when the tractor semi-trailer is in a cornering maneuver. In addition, the simulation results compare the performance between the passive and the LQR active anti - roll bar systems for semi-trailer show that by using the active system the reduction for the roll angle of the sprung mass is about 43%, 50% for the normalized load transfer and 50% for the roll angle of the unsprung mass.

**Keywords:** Tractor semi-trailer, Active anti roll bar, LQR control method, Roll stability, Rollover.

## 1 Introduction

Today, tractor semi-trailer heavy vehicles play an essential role in the transportation sector because of their merits. Compared to conventional trucks, tractor semi-trailer vehicles provide such benefits as reduction in fuel consumption per ton per kilometer leading to less emission, reduce transport costs thanks to increase in the transport volume and payload of one delivery time, and road protection due to reduced axle loads.

However, the accidents related to tractor semi-trailer usually are fatal and they often are caused by rollover accidents. There are three main factors leading to rollover accidents are side wind gusts, abrupt steering and braking manoeuvres by the driver. In these cases, roll stability occur when the tyre – road contact force of the wheels on one side of the vehicle equals zero. Hence, most of tractor semi-trailer equipped passive anti – roll bar at all axles in order to cope with the instability of tractor semi-trailer. However, it also has some drawbacks: the passive anti – roll bar system will transfer vertical forces of one side of the suspension to other side and leading moment to against the lateral force when driver control is in tractor semi-trailer cornering situation.

An active anti – roll bar system is applied to deal with these drawbacks. The active anti - roll bar includes a pair of hydraulic actuators [1], it generates a stabilizing moment to balance the overturning moment. Therefore, the lateral load response can reduce significantly.

The research on controlling the active roll control system for the tractor semi-trailer was conducted by a research team at the University of Cambridge in the United Kingdom. In [2] A.J.P. Miège and D. Cebon used PID control method to applied on an actual tractor semi-trailer, the authors had controlled the active ARB system to improve the vehicle roll stability. A semi active anti roll bar system is proposed by combining active and passive systems in [3]. In [4], [5], the authors designed a state feedback roll control system for a tractor semi-trailer using a flexible frame, which allowed a more accurate assessment of the benefits of this system. The mechanical properties of tires effect on instability of tractor-trailer at moderate levels of lateral acceleration indicated in [6].

The previous studies proposed an active anti roll bar system for both tractor and semi-trailer, while Sampson's results showed that the rear axle of semi-trailer is loss stability first [1]. Therefore, the objective control for semi-trailer is easier and exchangeable with other tractor as well as improve significantly the stability of tractor semi-trailer vehicles. Therefore, this is a new approach and more practical solution when compared with the previous studies.

The contributions of this paper are the following:

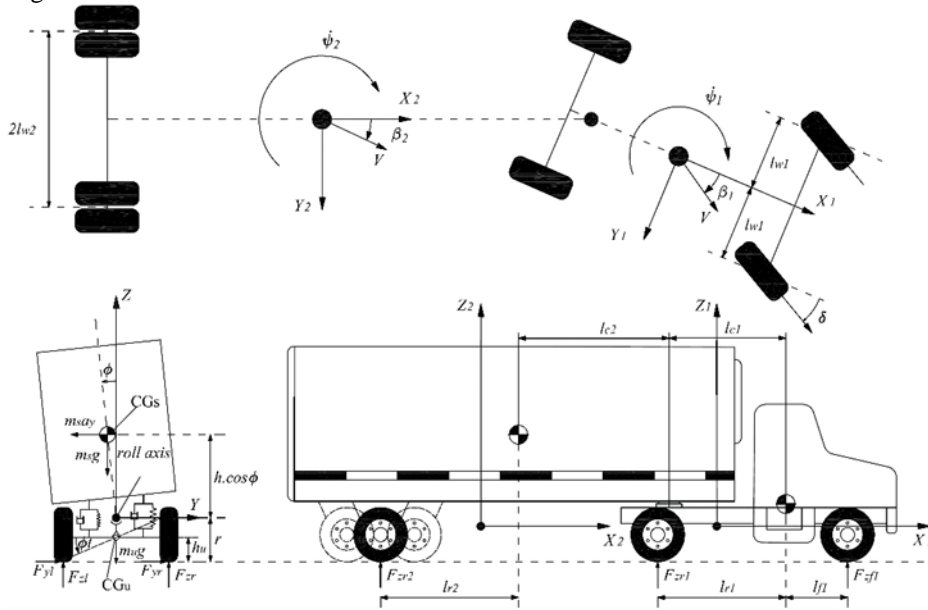
- A yaw - roll model of tractor semi-trailer is used for surveying the influence of structural parameters on the stability of the tractor semi-trailer, by considering the vertical and lateral displacement of the vehicle.
- An optimal LQR controller is designed at the semi-trailer axle in order to improve the roll stability of tractor semi-trailer.
- The simulation results in time domain and frequency domain show that the LQR active anti - roll bar system improves significantly the roll stability of tractor semi-trailer when compared with the passive anti - roll bar system.

## **2 Vehicle modelling**

### **2.1 Modeling of a tractor semi – trailer**

In this study, a yaw - roll model of tractor - semi-trailer in [7] is used in order to analyse characteristic dynamics with some assumptions: the tractor - semi-trailer is assumed to be perfectly rigid; pitching and bouncing motions have only a small effect on

the roll and handling behaviour of the vehicle and so can be neglected in formulating a model to investigate roll and handling performance. The effects of aerodynamic inputs (wind disturbances) and road inputs (cross-gradients, dips and bumps) are also neglected.



**Fig. 1.** Yaw – roll model of tractor - semi-trailer.

The vehicle body has the roll axis with distance  $r$  upwards from the ground. The dynamic equations of the vehicle are calculated by equating the change of momentum (or, in the rotational case, moment of momentum) with the sum of external forces (or moments) acting on the system. The motion is described using a coordinate system  $(x', y', z')$  fixed in the vehicle, as shown in Figure 1. The roll axis is replaced by an  $x'$  axis parallel to the ground, and the  $z'$  axis passes downward through the center of mass of the tractor - semi-trailer.

Figure 1 shows the tractor - semi-trailer model which includes two parts: tractor and semi-trailer, in which  $m_{st}$  is the sprung mass,  $m_u$  is the unsprung mass at the front axle, and  $m_r$  is the unsprung mass at the rear axle,  $h$  is the height of center of sprung mass,  $h_u$  is the height of center of unsprung mass,  $I_{st}$  is the roll moment of inertia of sprung mass,  $I_{st}$  is the yaw moment of inertia of sprung mass,  $I_{st}$  is the yaw roll moment of inertia of sprung mass,  $l_2$  is the longitudinal distance to articulation point, measured forwards from center of sprung mass,  $l_1$  is the longitudinal distance to articulation point, measured forwards from center of total mass of tractor or semi-trailer. The subscripts f and r express the front and rear axle of the tractor or trailer, respectively. The subscripts i (1 and 2) express the tractor and semi-trailer, respectively.  $F_{y1}$  is lateral force at the coupling point. The symbols and parameters of this model are shown in [7].

## 2.2 Dynamic equations of a tractor – semi-trailer

Equations (1) to (10) show the dynamic of the Yaw – Roll model of tractor – semi-trailer, in which: the yaw moment, the roll moment of the sprung mass, the roll moment of the front and rear unsprung masses of tractor are expressed in equations (1) to (5). The equations (6) to (8) describe the yaw moment of the sprung mass, the roll moment of the sprung mass, the roll moment of the rear unsprung mass of semi-trailer. The equation (9) denote the kinematic constraint between the tractor and the semi-trailer at the vehicle coupling [7]:

$$m_1 v (\dot{\beta}_1 + \dot{\psi}_1) - m_{s1} h \dot{\phi}_1 = F_{yf} + F_{yr} - F_C \quad (1)$$

$$I_{xz1} \ddot{\phi}_1 - I_{zz1} \ddot{\psi}_1 = F_{yr1} dl_{r1} - F_{yf1} dl_{f1} - b'_{r1} F_C - k_{\psi 1} (\psi_1 - \psi_2) \quad (2)$$

$$-m_{s1} a_y \dot{h}_{s1} - m_{s1} g \phi_1 h_{s1} + I_{xx1} \ddot{\phi}_1 - I_{xz1} \ddot{\psi}_1 + k_{f1} (\phi_1 - \phi_{f1}) + l_{f1} (\dot{\phi}_1 - \dot{\phi}_{f1}) \quad (3)$$

$$+ k_{r1} (\phi_1 - \phi_{r1}) + l_{r1} (\dot{\phi}_1 - \dot{\phi}_{r1}) + (h_{ar1} - r_1) F_C - k_{\phi 1} (\phi_1 - \phi_2) = 0$$

$$-F_{yf1} r_1 + (r_1 - h_{uf1}) m_{uf1} v (\dot{\beta}_1 + \dot{\psi}_1) + k_{uf1} \phi_{uf1} + (r_1 - h_{uf1}) m_{uf1} g \phi_{uf1} \quad (4)$$

$$-k_{f1} (\phi_1 - \phi_{f1}) - l_{f1} (\dot{\phi}_1 - \dot{\phi}_{f1}) = 0$$

$$-F_{yr1} r_1 + (r_1 - h_{ur1}) m_{ur1} v (\dot{\beta}_1 + \dot{\psi}_1) + k_{ur1} \phi_{ur1} + (r_1 - h_{ur1}) m_{ur1} g \phi_{ur1} \quad (5)$$

$$-k_{r1} (\phi_1 - \phi_{r1}) - l_{r1} (\dot{\phi}_1 - \dot{\phi}_{r1}) = 0$$

$$I_{xz2} \ddot{\phi}_2 - I_{zz2} \ddot{\psi}_2 = F_{yr2} dl_{r2} + b'_{f2} F_C - k_{\psi 1} (\psi_1 - \psi_2) \quad (6)$$

$$I_{xx2} \ddot{\phi}_2 - I_{xz2} \ddot{\psi}_2 - m_{s2} a_y \dot{h}_{s2} - m_{s2} g \phi_2 h_{s2} + k_{r2} (\phi_2 - \phi_{r2}) \quad (7)$$

$$+ l_{r2} (\dot{\phi}_2 - \dot{\phi}_{r2}) + u_{r2} - (h_{af2} - r_2) F_C + k_{\phi 1} (\phi_1 - \phi_2) = 0$$

$$-F_{yr2} r_2 - (h_{ur2} - r_2) m_{ur2} v (\dot{\beta}_2 + \dot{\psi}_2) - (h_{ur2} - r_2) m_{ur2} g \phi_{ur2} \quad (8)$$

$$-k_{r2} (\phi_2 - \phi_{r2}) - l_{r1} (\dot{\phi}_2 - \dot{\phi}_{r2}) + k_{ur2} \phi_{ur2} = 0$$

$$\beta_1 - \beta_2 - \frac{(r_1 - h_{ar1})}{v} \dot{\phi}_1 + \frac{(r_2 - h_{af2})}{v} \dot{\phi}_2 + \frac{b'_{r1}}{v} \dot{\psi}_1 - \frac{b'_{f2}}{v} \dot{\psi}_2 + \psi_1 - \psi_2 = 0 \quad (9)$$

The lateral tyre forces in the direction of velocity at the wheel ground connection points are modelled by using linear stiffness coefficients as:

$$\begin{aligned} F_{yfi} &= \mu C_f \alpha_f \\ F_{yri} &= \mu C_r \alpha_r \end{aligned} \quad (10)$$

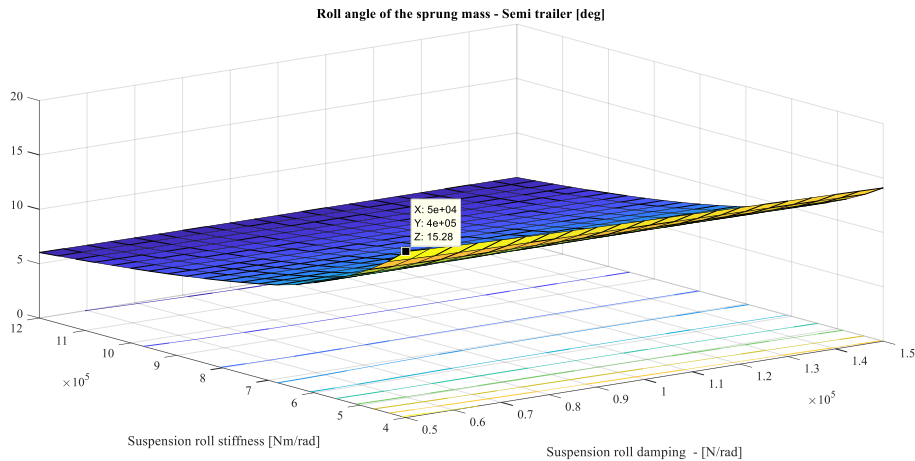
With the tyre side slip angles:

$$\alpha_{f1} = -\beta_1 + \delta_f - \frac{l_{f1} \dot{\psi}_1}{v} \quad \alpha_{r1} = -\beta_1 + \frac{l_{r1} \dot{\psi}_1}{v} \quad \alpha_{r2} = -\beta_2 + \frac{l_{r2} \dot{\psi}_2}{v} \quad (11)$$

The tractor semi-trailer is considered rollover when the wheel lifts off, means the normalized load transfer reach  $\pm 1$  [7].

### 3 Influence of structural parameters on tractor – semi-trailer stability

In this part, we use a cornering situation [8] as the common disturbance for studying the roll stability when the vehicle velocity is considered at 60 km/h. Fig.2 shows the time response of the roll angle of sprung mass when the characteristic of suspension roll damping and suspension roll stiffness change from (0.5 ÷ 1.5) standard value, in especially,  $(4.10^5 \div 12.10^5)$  Nm for suspension roll stiffness and  $(5.10^4 \div 15.10^5)$  Nm/rad for suspension roll damping.

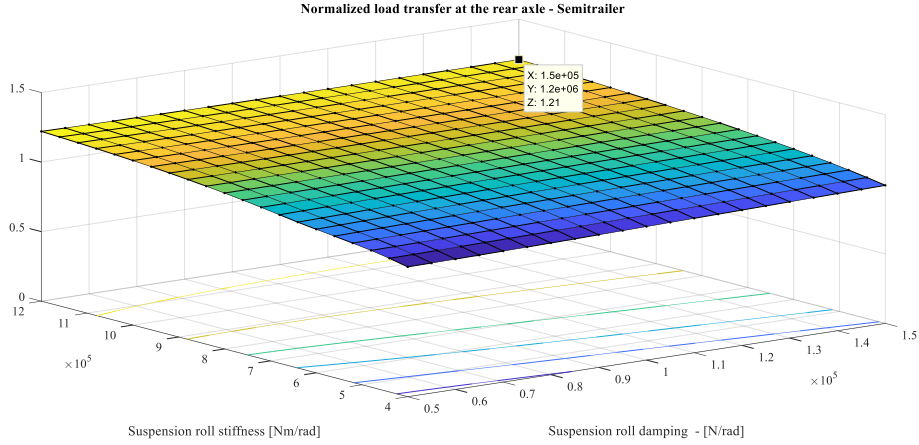


**Fig. 2.** Time responses of the roll angle of the sprung mass

As we see, the less value of suspension roll stiffness and suspension roll damping are, the more roll angle of the sprung mass of semi-trailer is and reach the peak at 15,28 degree when the value of suspension roll stiffness and suspension roll damping are the lowest. When these figures increase, the roll angle of the sprung mass of semi-trailer is decreased, respectively and it gets the lowest value at 6,03 degree. We also see that this roll angle of the sprung mass depends mainly on the suspension roll stiffness, the suspension roll damping affects insignificantly on it.

Fig.3 shows the time response of the normalized load transfer at rear axles of semi-trailer. We can see that when the value of suspension roll stiffness and suspension roll damping are low, the normalized load transfer is low and reach the lowest point at 0.93. This value rises to 1.21 when the value of suspension roll stiffness and suspension roll damping increase. However, the normalized load transfer also round 1. It is clear that the risk of rollover of this vehicle usually high when the velocity at 60 km/h although the value of suspension roll stiffness and suspension roll damping vary. Therefore,

designing an active anti roll bar system controller for tractor semi-trailer in order to improving the stability of this vehicle is very necessary.



**Fig. 3.** Time responses of the normalized load transfer

## 4 LQR controller design for active anti – roll bar system of semi – trailer

The motion differential equations from (1) to (11) can be rewritten in the LTI state – space representation as:

$$\begin{cases} \dot{x} = Ax + B_1w + B_2u \\ z = Cx + D_1w + D_2u \end{cases} \quad (12)$$

Where:

The state vector:  $x = [\beta_1 \ \dot{\psi}_1 \ \phi_1 \ \dot{\phi}_1 \ \phi_{r1} \ \dot{\phi}_{r1} \ \phi_2 \ \dot{\phi}_2 \ \beta_2 \ \dot{\psi}_2 \ \phi_{r2}]^T$ ,

The exogenous disturbance:  $w = [\delta]^T$ ,

The control input:  $u = [u_{r2}]^T$ ,

The output vector:  $z = x$ .

### 4.1 The control objectives for vehicle roll stability

The objective of the active anti-roll bar control system is to maximize the vehicle roll stability. In this paper, we would like to minimize the normalized load transfer of rear axle of semi-trailer to evaluate the vehicle roll stability of tractor semi-trailer vehicles:

$$|R| = \left| \frac{\Delta F_z}{F_z} \right| < 1 \quad (13)$$

where  $\Delta F_z$  is lateral load transfer and  $F_z$  total axle load of semi-trailer. If  $R$  takes the value  $\pm 1$ , the rollover occurs because the inner wheel in the bend lifts off and denoted in [8].

#### 4.2 LQR active anti – roll bar controller

The LTI model is noted by equation (12). For the controller design, it is assumed that all the states are available from measurements or can be estimated. Then, we consider the state feedback control law:

$$u = -Kx \quad (14)$$

where  $K$  is the state feedback gain matrix. The optimization procedure includes determining the control input  $u$  which minimizes some performance index  $J$ . This index includes the performance characteristic requirement as well as the controller input limitations, usually expressed by:  $J = \int_0^{\infty} (x^T Qx + u^T Ru) dt$ , where  $Q$  and  $R$  are the positive

definite weighting matrices. The optimal closed-loop system is obtained as follows [9]:

$$\dot{x} = (A - B_2 K)x + B_1 W \quad (15)$$

The performance index  $J$  is chosen as follows:

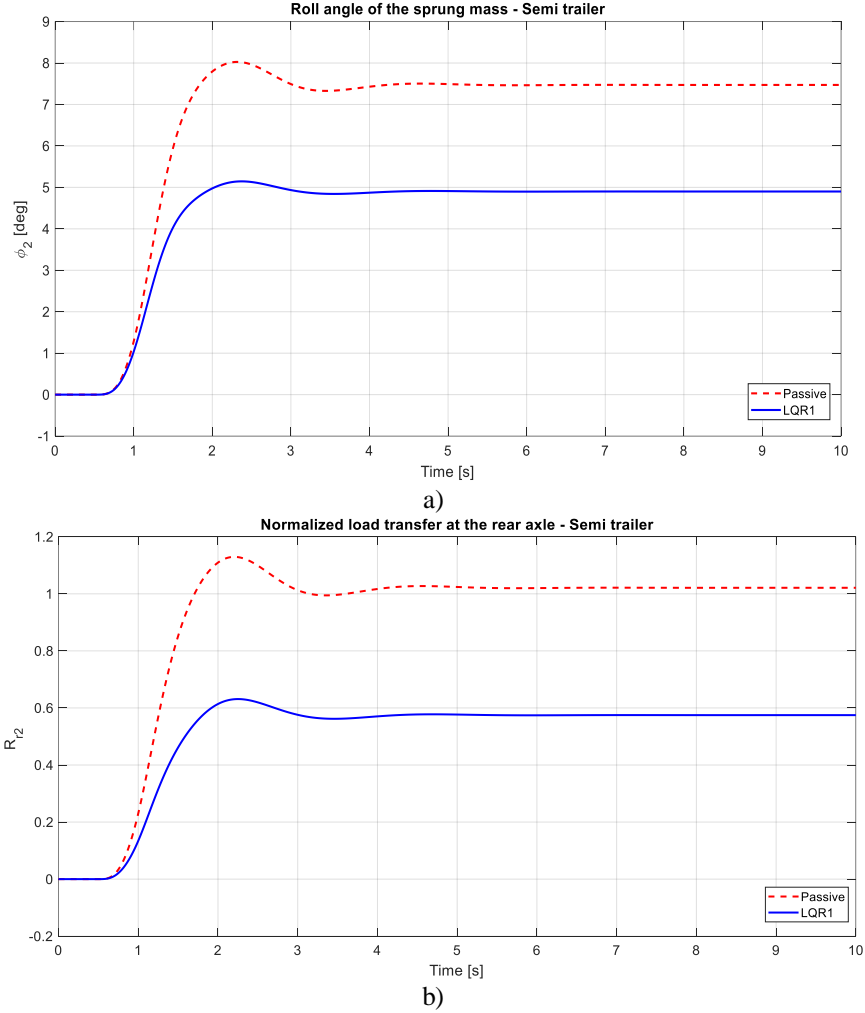
$$J = \int_0^{\infty} (\rho_1 \phi_2^2 + \rho_2 \dot{\phi}_2^2 + \rho_3 \beta_2^2 + \rho_4 \psi_2^2 + \rho_5 \dot{\phi}_{r2}^2) dt \quad (16)$$

Remark: The selection of  $J$  completely depends on the goal of the control design.  $\rho_1 = 10^{13}$ ;  $\rho_2 = 10$ ;  $\rho_3 = 10$ ;  $\rho_4 = 10$ ;  $\rho_5 = 10$  are the weighting parameters of  $J$ .

#### 4.3 The simulation results in the time domain

In this paper, we use a cornering situation [8] as the common disturbance for studying the roll stability. Fig.4 shows the time response of the steering angle, the roll angle of sprung mass, the roll angle of unsprung mass, the normalized load transfer at rear axles of semi-trailer when the vehicle velocity is considered at 60 km/h. We can see that the maximum value of these variables in LQR controller are always smaller than the passive anti roll bar system. The reduction is about 43% for the roll angle of the sprung mass, 50% for the normalized load transfer and 50% for the roll angle of the unsprung mass.

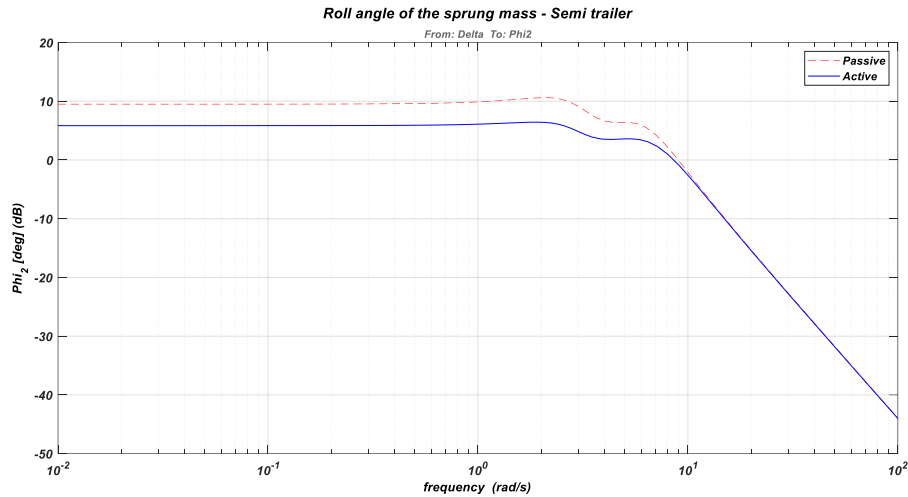




**Fig. 4.** Time responses of the roll angle of the sprung mass (a) and normalized load transfer at the rear axle (b) of semi-trailer.

#### 4.4 The simulation results in the frequency domain

We simulate tractor - semi-trailer model in the frequency range from  $10^{-2} \div 10^2 \text{ rad} / \text{s}$  with the control input is the steering angle. Fig 5 illustrates the transfer from steering angle to the roll angle of the sprung mass of semi-trailer. We can see, this value reduce 4dB in the frequency range of  $10^{-2} \div 4 \text{ rad} / \text{s}$ , which is respected for the driver bandwidth [8], [9]. We can conclude that by using LQR active anti-roll bar control system at the rear axle of semi-trailer, the roll stability of the tractor semi-trailer vehicles is significantly improved when compared with a passive system.



**Fig. 5.** Frequency responses when vehicle is in a cornering maneuver.

## 5 Conclusions

This paper has shown the effect of the suspension roll damping and roll stiffness parameters on the stability of the tractor semi-trailer and illustrated merits of the anti-roll bar system on tractor semi-trailer, particularly on semi-trailer during cornering situations. The LQR controller is applied on the rear axle of the semi-trailer, in which the lateral load transfer is taken into consideration. The obtained results have described the dramatically productivity of the LQR active anti-roll bar control to improve roll stability when compared with the passive anti-roll bar system.

This paper facilitates the application of the active anti-roll bar system on all axles of tractor semi-trailer in order to prevent the tractor semi-trailer vehicle rollover phenomenon in the future.

## References

1. Sampson DJM. Active roll control of articulated heavy vehicles. University of Cambridge, UK (2000).
2. A.J.P. Miège and D. Cebon. Design and Implementation of an Active Roll Control System for Heavy Vehicles. 5th International symposium on Advanced Vehicle Control, AVEC-2002, Hiroshima, Japan (2002)
3. Stone EJ, Cebon D. Control of semi-active antiroll systems on heavy vehicles. *Vehicle System Dynamics* 48(10), 1215–1243 (2010)
4. D.J.M. Sampson and D. Cebon. An Investigation of Roll Control System Design for Articulated Heavy Vehicles. 4th International symposium on Advanced Vehicle Control, AVEC-1998, Nagoya, Japan (1998)

5. Hsun-Hsuan Huang, Rama K. Yedavalli & Dennis A. Guenther. Active roll control for roll-over prevention of heavy articulated vehicles with multiple-rollover-index minimisation. *Vehicle System Dynamics* 50(3), 471-493 (2012)
6. L. Segel and R. D. Ervin. The influence of tire factors on the stability of trucks and truck-trailers. *Vehicle System Dynamics*, 10(1), 39-59 (1981)
7. Vu Van Tan, Olivier Sename, Péter Gáspár; Improving roll stability of tractor semi-trailer vehicles by using  $H_\infty$  active anti-roll bar control system; Proceedings of the Institution of Mechanical Engineers, Part D: Journal of Automobile Engineering, Published online first May 08 (2021)
8. Vu Van Tan, Nguyen Duy Hung. Using an LQR active anti-roll bar system to improve road safety of tractor semi-trailers. *Science & Technology Development Journal* 23(3), 593-601 (2020)
9. Gaspar P, Szabo Z, Bokor J. Prediction based combined control to prevent the rollover of heavy. Limassol, Cyprus: Proceedings of the 13th Mediterranean Conference on Control and Automation 10(2), 148-162 (2004)