



HAL
open science

Tensor algebra and analysis

Paolo Vannucci

► **To cite this version:**

| Paolo Vannucci. Tensor algebra and analysis. Master. France. 2021. hal-03298805v3

HAL Id: hal-03298805

<https://hal.science/hal-03298805v3>

Submitted on 17 Jan 2022

HAL is a multi-disciplinary open access archive for the deposit and dissemination of scientific research documents, whether they are published or not. The documents may come from teaching and research institutions in France or abroad, or from public or private research centers.

L'archive ouverte pluridisciplinaire **HAL**, est destinée au dépôt et à la diffusion de documents scientifiques de niveau recherche, publiés ou non, émanant des établissements d'enseignement et de recherche français ou étrangers, des laboratoires publics ou privés.

université
PARIS-SACLAY

A short course on
Tensor algebra and analysis

with application to differential geometry

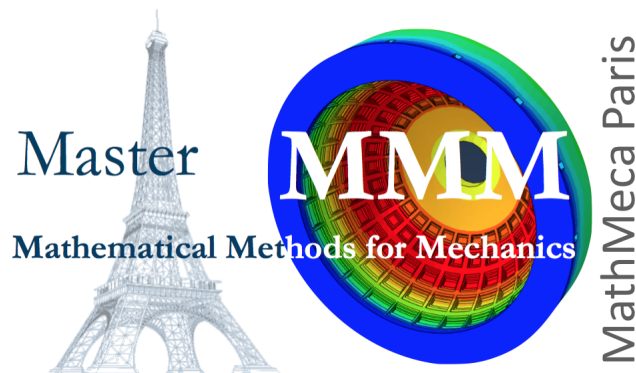

Paolo Vannucci
paolo.vannucci@uvsq.fr

Preface

This text is a support for different courses of the master of Mechanics of the University Paris-Saclay.

The content of this text is an introduction, for graduate students, to tensor algebra and analysis. Far from being exhaustive, the text focuses on some subjects, with the intention of providing the reader with the main algebraic tools necessary for a modern course in continuum mechanics.

The presentation of tensor algebra and analysis is intentionally done in Cartesian coordinates, that are normally used for classical problems. Then, an entire chapter is devoted to the passage to curvilinear coordinates and to the formalism of co- and contra-variant components.

The tensor theory and results are specially applied to introduce some subjects concerning differential geometry of curves and surfaces. Also in this case, the presentation is mainly intended for applications to continuum mechanics.

Versailles, November 5, 2021

Contents

Preface	iii
1 Points and vectors	1
1.1 Points and vectors	1
1.2 Scalar product, distance, orthogonality	3
1.3 Basis of \mathcal{V} , expression of the scalar product	4
1.4 Exercices	5
2 Second rank tensors	7
2.1 Second-rank tensors	7
2.2 Dyads, tensor components	8
2.3 Tensor product	9
2.4 Transpose, symmetric and skew tensors	9
2.5 Trace, scalar product of tensors	11
2.6 Spherical and deviatoric parts	12
2.7 Determinant, inverse of a tensor	13
2.8 Eigenvalues and eigenvectors of a tensor	16
2.9 Skew tensors and cross product	19
2.10 Orientation of a basis	23
2.11 Rotations	24
2.12 Reflexions	34
2.13 Polar decomposition	35
2.14 Exercices	37
3 Fourth rank tensors	39
3.1 Fourth-rank tensors	39
3.2 Dyads, tensor components	40
3.3 Conjugation product, transpose, symmetries	41
3.4 Trace and scalar product of fourth-rank tensors	43
3.5 Projectors, identities	44
3.6 Orthogonal conjugator	46
3.7 Rotations and symmetries	47
3.8 The Kelvin formalism	48
3.9 Exercices	50

4	Tensor analysis: curves	53
4.1	Curves of points, vectors and tensors	53
4.2	Differentiation of curves	54
4.3	Integral of a curve of vectors, length of a curve	57
4.4	The Frenet-Serret basis	60
4.5	Curvature of a curve	61
4.6	The Frenet-Serret formulae	64
4.7	The torsion of a curve	65
4.8	Osculating sphere and circle	66
4.9	Evolute, involute and envelopes of plane curves	68
4.10	The theorem of Bonnet	69
4.11	Canonic equations of a curve	70
4.12	Exercices	71
5	Tensor analysis: fields, deformations	75
5.1	Introduction	75
5.2	Scalar, vector and tensor fields	75
5.3	Differentiation of fields, differential operators	76
5.4	Theorems on fields	78
5.5	Differential operators in Cartesian coordinates	80
5.6	Differential operators in cylindrical coordinates	80
5.7	Differential operators in spherical coordinates	82
5.8	Exercices	83
6	Curvilinear coordinates	85
6.1	Introduction	85
6.2	Curvilinear coordinates, metric tensor	85
6.3	Co- and contra-variant components	88
6.4	Spatial derivatives of fields in curvilinear coordinates	93
6.5	Exercices	96
7	Surfaces in \mathcal{E}	99
7.1	Surfaces in \mathcal{E} , coordinate lines, tangent planes	99
7.2	Surfaces of revolution	101
7.3	Ruled surfaces	102
7.4	First fundamental form of a surface	103
7.5	Second fundamental form of a surface	105
7.6	Curvatures of a surface	107
7.7	The theorem of Rodrigues	110
7.8	Classification of the points of a surface	111
7.9	Developable surfaces	113
7.10	Points of a surface of revolution	114
7.11	Lines of curvature, conjugated directions, asymptotic directions	115
7.12	The Dupin's conical curves	117
7.13	The Gauss-Weingarten equations	118
7.14	The <i>Theorema Egregium</i>	119

7.15 Minimal surfaces	120
7.16 Geodesics	122
7.17 The Gauss-Codazzi compatibility conditions	126
7.18 Exercices	131
Suggested texts	133

Chapter 1

Points and vectors

1.1 Points and vectors

We consider in the following a *point space* \mathcal{E} , whose elements are points p^1 . On \mathcal{E} we admit the existence of an operation, the *difference* of any of its two elements:

$$q - p, \quad p, q \in \mathcal{E}.$$

We associate to \mathcal{E} a *vector space* \mathcal{V} whose dimension is $\dim \mathcal{V} = 3$ and whose elements are vectors \mathbf{v} representing *translations over* \mathcal{E} :

$$\forall p, q \in \mathcal{E}, \exists! \mathbf{v} \in \mathcal{V} \mid q - p = \mathbf{v}.$$

Any element $\mathbf{v} \in \mathcal{V}$ is hence a transformation over \mathcal{E} that can be written, using the previous definition, as :

$$\forall \mathbf{v} \in \mathcal{V}, \mathbf{v} : \mathcal{E} \rightarrow \mathcal{E} \mid q = \mathbf{v}(p) \rightarrow q = p + \mathbf{v}.$$

To remark that the result of the application of the translation \mathbf{v} depends upon the argument p :

$$q = p + \mathbf{v} \neq p' + \mathbf{v} = q',$$

whose geometric meaning is depicted in Fig. 1.1. Unlike difference, the sum of two points is not defined and is meaningless.

We define the *sum of two vectors* \mathbf{u} and \mathbf{v} as the vector \mathbf{w} such that

$$(\mathbf{u} + \mathbf{v})(p) = \mathbf{u}(\mathbf{v}(p)) = \mathbf{w}(p)$$

This means that, if

$$q = \mathbf{v}(p) = p + \mathbf{v},$$

then

$$r = \mathbf{u}(q) = q + \mathbf{u} = \mathbf{w}(p),$$

¹ \mathcal{E} is to be identified with the *Euclidean three-dimensional space* in which the events of classical mechanics are intended to be set.

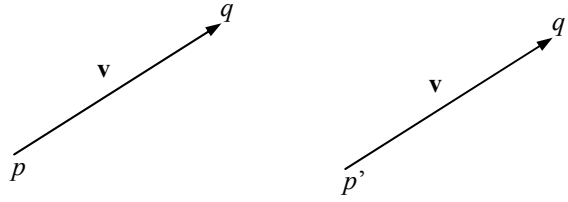

Figure 1.1: Same translation over two different points.

see Fig. 1.2, which shows that the above definition actually coincides with the parallelogram rule and that

$$\mathbf{u} + \mathbf{v} = \mathbf{v} + \mathbf{u},$$

as obvious, for the sum over a vector space commutes. It is evident that the sum of more than two vectors can be defined iteratively, summing up a vector at time to the sum of the previous vectors.

The *null vector* \mathbf{o} is defined as the difference of two coincident points:

$$\mathbf{o} = p - p \quad \forall p \in \mathcal{E};$$

\mathbf{o} is unique and the only vector such that

$$\mathbf{v} + \mathbf{o} = \mathbf{v} \quad \forall \mathbf{v} \in \mathcal{V}.$$

In fact:

$$\forall p \in \mathcal{E}, \quad \mathbf{v} + \mathbf{o} = \mathbf{v} + p - p \rightarrow p + \mathbf{v} + \mathbf{o} = p + \mathbf{v} \iff \mathbf{v} + \mathbf{o} = \mathbf{v}.$$

A *linear combination* of n vectors \mathbf{v}_i is defined as the vector²

$$\mathbf{w} = k_i \mathbf{v}_i, \quad k_i \in \mathbb{R}, \quad i = 1, \dots, n.$$

The $n + 1$ vectors \mathbf{w} , \mathbf{v}_i , $i = 1, \dots, n$, are said to be *linear independent* if it does not exist a set of n scalars k_i such that the above equation is satisfied, *linear dependent* in the opposite case.

²We adopt here and in the following the *Einstein notation* for summations: all the times that an index is repeated in a monomial, then summation with respect to that index, called the *dummy index*, is understood. If a repeated index is underlined, then it is not a dummy index, i.e. there is no summation.

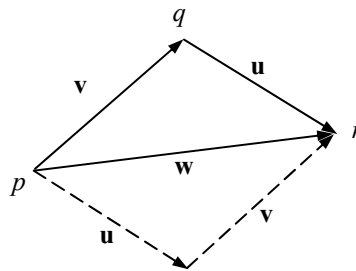

Figure 1.2: Sum of two vectors: the parallelogram rule.

1.2 Scalar product, distance, orthogonality

A *scalar product* on a vector space is a positive definite, symmetric, bilinear form. A *form* ω is a function

$$\omega : \mathcal{V} \times \mathcal{V} \rightarrow \mathbb{R},$$

i.e., ω operates on a couple of vectors to give a real number, a *scalar*. We will indicate the scalar product of two vectors \mathbf{u} and \mathbf{v} as

$$\omega(\mathbf{u}, \mathbf{v}) = \mathbf{u} \cdot \mathbf{v}.$$

The properties of *bilinearity* prescribe that, $\forall \mathbf{u}, \mathbf{v} \in \mathcal{V}$ and $\forall \alpha, \beta \in \mathbb{R}$,

$$\begin{aligned}\mathbf{u} \cdot (\alpha \mathbf{v} + \beta \mathbf{w}) &= \alpha \mathbf{u} \cdot \mathbf{v} + \beta \mathbf{u} \cdot \mathbf{w}, \\ (\alpha \mathbf{u} + \beta \mathbf{v}) \cdot \mathbf{w} &= \alpha \mathbf{u} \cdot \mathbf{w} + \beta \mathbf{v} \cdot \mathbf{w},\end{aligned}$$

while *symmetry* implies that

$$\mathbf{u} \cdot \mathbf{v} = \mathbf{v} \cdot \mathbf{u} \quad \forall \mathbf{u}, \mathbf{v} \in \mathcal{V}.$$

Finally, the *positive definiteness* means that

$$\mathbf{v} \cdot \mathbf{v} > 0 \quad \forall \mathbf{v} \in \mathcal{V}, \quad \mathbf{v} \cdot \mathbf{v} = 0 \iff \mathbf{v} = \mathbf{o}.$$

Any two vectors are said to be *orthogonal* \iff

$$\mathbf{u} \cdot \mathbf{v} = 0.$$

Thanks to the properties of the scalar product, we can define the *Euclidean norm* of a vector \mathbf{v} as the nonnegative scalar, denoted equivalently by v or $|\mathbf{v}|$,

$$v = |\mathbf{v}| = \sqrt{\mathbf{v} \cdot \mathbf{v}}$$

The norm of a vector has the following properties:

$$\begin{aligned}|\mathbf{u} + \mathbf{v}| &\leq u + v \quad (\text{Minkowski's triangular inequality}); \\ |\mathbf{u} \cdot \mathbf{v}| &\leq u v \quad (\text{Schwarz's inequality}); \\ |k\mathbf{v}| &= |k|v, \quad k \in \mathbb{R}.\end{aligned}$$

We define *distance between two any points* p and $q \in \mathcal{E}$ the scalar

$$d(p, q) = |p - q| = |q - p|.$$

Similarly, the *distance between two any vectors* \mathbf{u} and $\mathbf{v} \in \mathcal{V}$ is defined as

$$d(\mathbf{u}, \mathbf{v}) = |\mathbf{u} - \mathbf{v}| = |\mathbf{v} - \mathbf{u}|.$$

Two points or two vectors are *coincident* if and only if their distance is null.

The *unit sphere* \mathcal{S} of \mathcal{V} is defined as the set of all the vectors whose norm is one:

$$\mathcal{S} = \{\mathbf{v} \in \mathcal{V} \mid v = 1\}.$$

1.3 Basis of \mathcal{V} , expression of the scalar product

Generally speaking, a *basis* \mathcal{B} of a vector space is any set of n linearly independent vectors, where n is equal to the dimension of the vector space. In the case of \mathcal{V} , $n = 3$, so that a basis \mathcal{B} of \mathcal{V} is any set

$$\mathcal{B} = \{\mathbf{e}_1, \mathbf{e}_2, \mathbf{e}_3\},$$

of three linearly independent vectors \mathbf{e}_i . The concept of *basis of \mathcal{V}* is useful for representing vectors: once a basis chosen, any vector $\mathbf{v} \in \mathcal{V}$ can be represented as a linear combination of the vectors of the basis, where the coefficients v_i of the linear combination are the *components* of \mathbf{v} :

$$\mathbf{v} = v_i \mathbf{e}_i = v_1 \mathbf{e}_1 + v_2 \mathbf{e}_2 + v_3 \mathbf{e}_3.$$

Though the choice of the elements of a basis is completely arbitrary, the only condition being their linear independency, we will use in the following only *orthonormal bases*, that are bases composed by mutually orthogonal vectors of \mathcal{S} , i.e. satisfying

$$\mathbf{e}_i \cdot \mathbf{e}_j = \delta_{ij},$$

where the symbol δ_{ij} is the so-called *Kronecker's delta*:

$$\delta_{ij} = \begin{cases} 1 & \text{if } i = j, \\ 0 & \text{if } i \neq j. \end{cases}$$

The use of orthonormal bases has great advantages; for instance, it allows to give a very simple rule for the calculation of the scalar product:

$$\mathbf{u} \cdot \mathbf{v} = u_i \mathbf{e}_i \cdot v_j \mathbf{e}_j = u_i v_j \delta_{ij} = u_i v_i = u_1 v_1 + u_2 v_2 + u_3 v_3.$$

In particular, it is

$$\mathbf{v} \cdot \mathbf{e}_i = v_k \mathbf{e}_k \cdot \mathbf{e}_i = v_k \delta_{ik} = v_i, \quad i = 1, 2, 3.$$

So, the *Cartesian components* of a vector are the projection of the vector on the three vectors of the basis \mathcal{B} ; such quantities are the *director cosines* of \mathbf{v} in the basis \mathcal{B} . In fact, if θ is the angle formed by two vectors \mathbf{u} and \mathbf{v} , then

$$\mathbf{u} \cdot \mathbf{v} = u v \cos \theta.$$

This relation is used to define the angle between two vectors,

$$\theta = \arccos \frac{\mathbf{u} \cdot \mathbf{v}}{u v},$$

which can be proved easily: given two vectors \mathbf{u} and \mathbf{v} , we look for $c \in \mathbb{R}$ such that the vector $\mathbf{u} - c\mathbf{v}$ be orthogonal to \mathbf{v} :

$$(\mathbf{u} - c\mathbf{v}) \cdot \mathbf{v} = 0 \iff c = \frac{\mathbf{u} \cdot \mathbf{v}}{\mathbf{v} \cdot \mathbf{v}} = \frac{\mathbf{u} \cdot \mathbf{v}}{v^2}.$$

Now, if \mathbf{u} is inclined of θ on \mathbf{v} , its projection u_v on the direction of \mathbf{v} is

$$u_v = u \cos \theta,$$

and, by construction (see Fig. 1.3), it is also

$$u_v = c v.$$

So

$$c = \frac{u}{v} \cos \theta \rightarrow \frac{u}{v} \cos \theta = \frac{\mathbf{u} \cdot \mathbf{v}}{v^2} \Rightarrow \cos \theta = \frac{\mathbf{u} \cdot \mathbf{v}}{u v}.$$

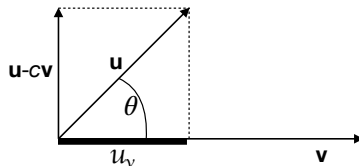

Figure 1.3: Angle between two vectors.

To remark that, while the scalar product, being an intrinsic operation, does not change for a change of basis, the components v_i of a vector are *not* intrinsic quantities, but they are basis-dependent: a change of the basis makes the components change. The way this change is done will be introduced in Sect. 2.11.

A *frame* \mathcal{R} for \mathcal{E} is composed by a point $o \in \mathcal{E}$, the *origin*, and a basis \mathcal{B} of \mathcal{V} :

$$\mathcal{R} = \{o, \mathcal{B}\} = \{o; \mathbf{e}_1, \mathbf{e}_2, \mathbf{e}_3\}.$$

The use of a frame for \mathcal{E} is useful for determining the position of a point p , which can be done through its *Cartesian coordinates* x_i , defined as the components, in \mathcal{B} , of the vector $p - o$:

$$x_i = (p - o) \cdot \mathbf{e}_i, \quad i = 1, 2, 3.$$

Of course, the coordinates depend upon both the choices of o and of \mathcal{B} .

1.4 Exercices

1. Prove that the null vector is unique.
2. Prove that the norm of the null vector is zero.
3. Prove the inequality of Minkowski.
4. Prove the inequality of Schwarz.
5. Prove that

$$\mathbf{u} \cdot \mathbf{v} = 0 \iff |\mathbf{u} - \mathbf{v}| = |\mathbf{u} + \mathbf{v}| \quad \forall \mathbf{u}, \mathbf{v} \in \mathcal{V}.$$

6. Prove the *linear forms representation theorem*: be $\psi : \mathcal{V} \rightarrow \mathbb{R}$ a linear function. Then, $\exists! \mathbf{u} \in \mathcal{V}$ such that

$$\psi(\mathbf{v}) = \mathbf{u} \cdot \mathbf{v} \quad \forall \mathbf{v} \in \mathcal{V}.$$

Chapter 2

Second rank tensors

2.1 Second-rank tensors

A *second-rank tensor* \mathbf{L} is any linear application from \mathcal{V} to \mathcal{V} :

$$\mathbf{L} : \mathcal{V} \rightarrow \mathcal{V} \mid \mathbf{L}(\alpha_i \mathbf{u}_i) = \alpha_i \mathbf{L}\mathbf{u}_i \quad \forall \alpha_i \in \mathbb{R}, \mathbf{u}_i \in \mathcal{V}, i = 1, \dots, n.$$

Though here \mathcal{V} indicates the vector space of translations over \mathcal{E} , the definition of tensor¹ is more general and in particular \mathcal{V} can be any vector space.

Defining the *sum of two tensors* as

$$(\mathbf{L}_1 + \mathbf{L}_2)\mathbf{u} = \mathbf{L}_1\mathbf{u} + \mathbf{L}_2\mathbf{u} \quad \forall \mathbf{u} \in \mathcal{V}, \quad (2.1)$$

the *product of a scalar by a tensor* as

$$(\alpha \mathbf{L})\mathbf{u} = \alpha(\mathbf{L}\mathbf{u}) \quad \forall \alpha \in \mathbb{R}, \mathbf{u} \in \mathcal{V}$$

and the *null tensor* \mathbf{O} as the unique tensor such that

$$\mathbf{O}\mathbf{u} = \mathbf{o} \quad \forall \mathbf{u} \in \mathcal{V},$$

then the set of all the tensors \mathbf{L} that operate on \mathcal{V} forms a vector space, denoted by $Lin(\mathcal{V})$. We define the *identity tensor* \mathbf{I} as the unique tensor such that

$$\mathbf{I}\mathbf{u} = \mathbf{u} \quad \forall \mathbf{u} \in \mathcal{V}.$$

Different possible operations can be defined for second-rank tensors. We consider all of them in the following Sections.

¹We consider for the while only second-rank tensors, but we will see in the following how to introduce tensors of higher ranks.

2.2 Dyads, tensor components

For any couple of vectors \mathbf{u} and \mathbf{v} , the *dyad*² $\mathbf{u} \otimes \mathbf{v}$ is the tensor defined by

$$(\mathbf{u} \otimes \mathbf{v})\mathbf{w} = \mathbf{v} \cdot \mathbf{w} \mathbf{u} \quad \forall \mathbf{w} \in \mathcal{V}.$$

The application defined above is actually a tensor because of the bi-linearity of the scalar product. The introduction of dyads allows for expressing any tensor as a linear combination of dyads. In fact, it can be proved that if $\mathcal{B} = \{\mathbf{e}_1, \mathbf{e}_2, \mathbf{e}_3\}$ is a basis of \mathcal{V} , then the set of 9 dyads

$$\mathcal{B}^2 = \{\mathbf{e}_i \otimes \mathbf{e}_j, \quad i, j = 1, 2, 3\},$$

is a basis of $Lin(\mathcal{V})$, i.e. $\dim(Lin(\mathcal{V})) = 9$. This implies that any tensor $\mathbf{L} \in Lin(\mathcal{V})$ can be expressed as

$$\mathbf{L} = L_{ij} \mathbf{e}_i \otimes \mathbf{e}_j, \quad i, j = 1, 2, 3,$$

where the L_{ij} s are the nine *Cartesian components* of \mathbf{L} with respect to \mathcal{B}^2 . The L_{ij} s can be calculated easily:

$$\mathbf{e}_i \cdot \mathbf{L}\mathbf{e}_j = \mathbf{e}_i \cdot L_{hk} \mathbf{e}_h \otimes \mathbf{e}_k \mathbf{e}_j = L_{hk} \mathbf{e}_i \cdot \mathbf{e}_h \mathbf{e}_k \cdot \mathbf{e}_j = L_{hk} \delta_{ih} \delta_{jk} = L_{ij}.$$

The above expression is sometimes called the *canonical decomposition of a tensor*. The components of a dyad can be computed easily:

$$(\mathbf{u} \otimes \mathbf{v})_{ij} = \mathbf{e}_i \cdot (\mathbf{u} \otimes \mathbf{v}) \mathbf{e}_j = \mathbf{u} \cdot \mathbf{e}_i \mathbf{v} \cdot \mathbf{e}_j = u_i v_j. \quad (2.2)$$

The components of a vector \mathbf{v} result of the application of a tensor \mathbf{L} on a vector \mathbf{u} can now be easily calculated:

$$\mathbf{v} = \mathbf{L}\mathbf{u} = L_{ij}(\mathbf{e}_i \otimes \mathbf{e}_j)(u_k \mathbf{e}_k) = L_{ij} u_k \delta_{jk} \mathbf{e}_i = L_{ij} u_j \mathbf{e}_i \rightarrow v_i = L_{ij} u_j. \quad (2.3)$$

Depending upon two indices, any second-rank tensor \mathbf{L} can be represented by a matrix, whose entries are the Cartesian components of \mathbf{L} in the basis \mathcal{B} :

$$\mathbf{L} = \begin{bmatrix} L_{11} & L_{12} & L_{13} \\ L_{21} & L_{22} & L_{23} \\ L_{31} & L_{32} & L_{33} \end{bmatrix};$$

because any $\mathbf{u} \in \mathcal{V}$, depending upon only one index, can be represented by a column vector, eq. (2.3) represents actually the classical operation of the multiplication of a 3×3 matrix by a 3×1 vector.

²In some texts, the dyad is also called *tensor product*; we prefer to use the term dyad because tensor product can be ambiguous, as used to denote the product of two tensors, see Sect. 2.3.

2.3 Tensor product

The *tensor product* of \mathbf{L}_1 and $\mathbf{L}_2 \in \text{Lin}(\mathcal{V})$ is defined as

$$(\mathbf{L}_1\mathbf{L}_2)\mathbf{v} = \mathbf{L}_1(\mathbf{L}_2\mathbf{v}) \quad \forall \mathbf{v} \in \mathcal{V}.$$

By linearity and eq. (2.1) we get

$$\begin{aligned} [\mathbf{L}(\mathbf{L}_1 + \mathbf{L}_2)]\mathbf{v} &= \mathbf{L}[(\mathbf{L}_1 + \mathbf{L}_2)\mathbf{v}] = \mathbf{L}(\mathbf{L}_1\mathbf{v} + \mathbf{L}_2\mathbf{v}) = \\ \mathbf{L}\mathbf{L}_1\mathbf{v} + \mathbf{L}\mathbf{L}_2\mathbf{v} &= (\mathbf{L}\mathbf{L}_1 + \mathbf{L}\mathbf{L}_2)\mathbf{v} \rightarrow \mathbf{L}(\mathbf{L}_1 + \mathbf{L}_2) = \mathbf{L}\mathbf{L}_1 + \mathbf{L}\mathbf{L}_2. \end{aligned}$$

To remark that the tensor product is not symmetric:

$$\mathbf{L}_1\mathbf{L}_2 \neq \mathbf{L}_2\mathbf{L}_1;$$

however, by the same definition of the identity tensor and of tensor product,

$$\mathbf{I}\mathbf{L} = \mathbf{L}\mathbf{I} = \mathbf{L} \quad \forall \mathbf{L} \in \text{Lin}(\mathcal{V}).$$

The Cartesian components of a tensor $\mathbf{L} = \mathbf{A}\mathbf{B}$ can be easily calculated using eq. (2.3):

$$\begin{aligned} L_{ij} &= \mathbf{e}_i \cdot (\mathbf{A}\mathbf{B})\mathbf{e}_j = \mathbf{e}_i \cdot \mathbf{A}(\mathbf{B}\mathbf{e}_j) = \mathbf{e}_i \cdot \mathbf{A}(B_{hk}(\mathbf{e}_j)_k \mathbf{e}_h) = B_{hk}\delta_{jk}\mathbf{e}_i \cdot \mathbf{A}\mathbf{e}_h \\ &= B_{hk}\delta_{jk}\mathbf{e}_i \cdot (A_{pq}(\mathbf{e}_h)_q \mathbf{e}_p) = A_{pq}B_{hk}\delta_{jk}\delta_{qh}\delta_{ip} = A_{ih}B_{hj}. \end{aligned}$$

The above result simply corresponds to the rule of the multiplication of rows by lines of two matrices. Using it, the following two identities can be readily shown:

$$\begin{aligned} (\mathbf{a} \otimes \mathbf{b})(\mathbf{c} \otimes \mathbf{d}) &= \mathbf{b} \cdot \mathbf{c}(\mathbf{a} \otimes \mathbf{d}) \quad \forall \mathbf{a}, \mathbf{b}, \mathbf{c}, \mathbf{d} \in \mathcal{V}, \\ \mathbf{A}(\mathbf{a} \otimes \mathbf{b}) &= (\mathbf{A}\mathbf{a}) \otimes \mathbf{b} \quad \forall \mathbf{a}, \mathbf{b} \in \mathcal{V}, \mathbf{A} \in \text{Lin}(\mathcal{V}). \end{aligned} \tag{2.4}$$

Finally, the symbol \mathbf{L}^2 is normally used to denote in short the product $\mathbf{L}\mathbf{L}$, $\forall \mathbf{L} \in \text{Lin}(\mathcal{V})$.

2.4 Transpose, symmetric and skew tensors

For any tensor $\mathbf{L} \in \text{Lin}(\mathcal{V})$, it exists just one tensor \mathbf{L}^\top , called the *transpose* of \mathbf{L} , such that

$$\mathbf{u} \cdot \mathbf{L}\mathbf{v} = \mathbf{v} \cdot \mathbf{L}^\top\mathbf{u} \quad \forall \mathbf{u}, \mathbf{v} \in \mathcal{V}.$$

The transpose of the transpose of \mathbf{L} is \mathbf{L} :

$$\mathbf{u} \cdot \mathbf{L}\mathbf{v} = \mathbf{v} \cdot \mathbf{L}^\top\mathbf{u} = \mathbf{u} \cdot (\mathbf{L}^\top)^\top\mathbf{v} \Rightarrow (\mathbf{L}^\top)^\top = \mathbf{L}.$$

The Cartesian components of \mathbf{L}^\top are obtained swapping the indexes of the components of \mathbf{L} :

$$L_{ij}^\top = \mathbf{e}_i \cdot \mathbf{L}^\top\mathbf{e}_j = \mathbf{e}_j \cdot (\mathbf{L}^\top)^\top\mathbf{e}_i = \mathbf{e}_j \cdot \mathbf{L}\mathbf{e}_i = L_{ji}.$$

It is immediate to show that

$$(\mathbf{A} + \mathbf{B})^\top = \mathbf{A}^\top + \mathbf{B}^\top \quad \forall \mathbf{A}, \mathbf{B} \in \text{Lin}(\mathcal{V}),$$

while

$$\mathbf{u} \cdot (\mathbf{AB})\mathbf{v} = \mathbf{B}\mathbf{v} \cdot \mathbf{A}^\top \mathbf{u} = \mathbf{v} \cdot \mathbf{B}^\top \mathbf{A}^\top \mathbf{u} \Rightarrow (\mathbf{AB})^\top = \mathbf{B}^\top \mathbf{A}^\top.$$

Moreover,

$$\mathbf{u} \cdot (\mathbf{a} \otimes \mathbf{b})\mathbf{v} = \mathbf{a} \cdot \mathbf{u} \mathbf{b} \cdot \mathbf{v} = \mathbf{v} \cdot (\mathbf{b} \otimes \mathbf{a})\mathbf{u} \Rightarrow (\mathbf{a} \otimes \mathbf{b})^\top = \mathbf{b} \otimes \mathbf{a}. \quad (2.5)$$

A tensor \mathbf{L} is *symmetric* \iff

$$\mathbf{L} = \mathbf{L}^\top.$$

In such a case

$$L_{ij} = L_{ij}^\top = L_{ji} \iff L_{ij} = L_{ji}.$$

A symmetric tensor is hence represented, in a given basis, by a symmetric matrix and has just six independent Cartesian components. Applying eq. (2.4) to \mathbf{I} , it is immediately recognized that the identity tensor is symmetric: $\mathbf{I} = \mathbf{I}^\top$.

A tensor \mathbf{L} is *antisymmetric* or *skew* \iff

$$\mathbf{L} = -\mathbf{L}^\top.$$

In such a case (no summation on the index i , see footnote 2, Chap. 1)

$$L_{ij} = -L_{ij}^\top = -L_{ji} \iff L_{ij} = -L_{ji} \Rightarrow L_{ii} = 0 \quad \forall i = 1, 2, 3.$$

A skew tensor is hence represented, in a given basis, by an antisymmetric matrix whose components on the diagonal are identically null, in any basis; finally, a skew tensor just depends upon three independent Cartesian components.

If we denote by $\text{Sym}(\mathcal{V})$ the set of all the symmetric tensors and by $\text{Skw}(\mathcal{V})$ that of all the skew tensors, then it is evident that, $\forall \alpha, \beta, \lambda, \mu \in \mathbb{R}$,

$$\begin{aligned} \text{Sym}(\mathcal{V}) \cap \text{Skw}(\mathcal{V}) &= \mathbf{O}, \\ \alpha \mathbf{A} + \beta \mathbf{B} &\in \text{Sym}(\mathcal{V}) \quad \forall \mathbf{A}, \mathbf{B} \in \text{Sym}(\mathcal{V}), \\ \lambda \mathbf{L} + \mu \mathbf{M} &\in \text{Skw}(\mathcal{V}) \quad \forall \mathbf{L}, \mathbf{M} \in \text{Skw}(\mathcal{V}), \end{aligned}$$

so $\text{Sym}(\mathcal{V})$ and $\text{Skw}(\mathcal{V})$ are vector subspaces of $\text{Lin}(\mathcal{V})$ with $\dim(\text{Sym}(\mathcal{V})) = 6$, while $\dim(\text{Skw}(\mathcal{V})) = 3$.

Any tensor \mathbf{L} can be decomposed into the sum of a symmetric, \mathbf{L}^s , and an antisymmetric, \mathbf{L}^a , tensor:

$$\mathbf{L} = \mathbf{L}^s + \mathbf{L}^a,$$

with

$$\mathbf{L}^s = \frac{\mathbf{L} + \mathbf{L}^\top}{2} \in \text{Sym}(\mathcal{V})$$

and

$$\mathbf{L}^a = \frac{\mathbf{L} - \mathbf{L}^\top}{2} \in \text{Skw}(\mathcal{V}),$$

so that, finally,

$$\text{Lin}(\mathcal{V}) = \text{Sym}(\mathcal{V}) \oplus \text{Skw}(\mathcal{V}).$$

2.5 Trace, scalar product of tensors

It exists one and only one linear form

$$\text{tr} : \text{Lin}(\mathcal{V}) \rightarrow \mathbb{R},$$

called the *trace*, such that

$$\text{tr}(\mathbf{a} \otimes \mathbf{b}) = \mathbf{a} \cdot \mathbf{b} \quad \forall \mathbf{a}, \mathbf{b} \in \mathcal{V}.$$

For its same definition, that has been given without making use of any basis of \mathcal{V} , the trace of a tensor is a *tensor invariant*, i.e. a quantity, extracted from a tensor, that does not depend upon the basis.

Linearity implies that

$$\text{tr}(\alpha \mathbf{A} + \beta \mathbf{B}) = \alpha \text{tr} \mathbf{A} + \beta \text{tr} \mathbf{B} \quad \forall \alpha, \beta \in \mathbb{R}, \mathbf{A}, \mathbf{B} \in \text{Lin}(\mathcal{V}).$$

It is just the linearity to give the rule for calculating the trace of a tensor \mathbf{L} :

$$\text{tr} \mathbf{L} = \text{tr}(L_{ij} \mathbf{e}_i \otimes \mathbf{e}_j) = L_{ij} \text{tr}(\mathbf{e}_i \otimes \mathbf{e}_j) = L_{ij} \mathbf{e}_i \cdot \mathbf{e}_j = L_{ij} \delta_{ij} = L_{ii}.$$

A tensor is hence an operator whose sum of the components on the diagonal,

$$\text{tr} \mathbf{L} = L_{11} + L_{22} + L_{33},$$

is constant, regardless of the basis.

Following the same procedure above, it is readily seen that

$$\text{tr} \mathbf{L}^\top = \text{tr} \mathbf{L},$$

which implies, by linearity, that

$$\text{tr} \mathbf{L} = 0 \quad \forall \mathbf{L} \in \text{Skw}(\mathcal{V}).$$

The *scalar product* of tensors \mathbf{A} and \mathbf{B} is the positive definite, symmetric bilinear form defined by

$$\mathbf{A} \cdot \mathbf{B} = \text{tr}(\mathbf{A}^\top \mathbf{B}).$$

This definition implies that, $\forall \mathbf{L}, \mathbf{M}, \mathbf{N} \in \text{Lin}(\mathcal{V}), \alpha, \beta \in \mathbb{R}$,

$$\begin{aligned} \mathbf{L} \cdot (\alpha \mathbf{M} + \beta \mathbf{N}) &= \alpha \mathbf{L} \cdot \mathbf{M} + \beta \mathbf{L} \cdot \mathbf{N}, \\ (\alpha \mathbf{L} + \beta \mathbf{M}) \cdot \mathbf{N} &= \alpha \mathbf{L} \cdot \mathbf{N} + \beta \mathbf{M} \cdot \mathbf{N}, \\ \mathbf{L} \cdot \mathbf{M} &= \mathbf{M} \cdot \mathbf{L}, \\ \mathbf{L} \cdot \mathbf{L} > 0 \quad \forall \mathbf{L} \in \text{Lin}(\mathcal{V}), \quad \mathbf{L} \cdot \mathbf{L} = 0 &\iff \mathbf{L} = \mathbf{O}. \end{aligned}$$

Such properties give the rule for computing the scalar product of two tensors \mathbf{A} and \mathbf{B} :

$$\begin{aligned} \mathbf{A} \cdot \mathbf{B} &= A_{ij}(\mathbf{e}_i \otimes \mathbf{e}_j) \cdot B_{hk}(\mathbf{e}_h \otimes \mathbf{e}_k) = A_{ij} B_{hk} (\mathbf{e}_i \otimes \mathbf{e}_j) \cdot (\mathbf{e}_h \otimes \mathbf{e}_k) \\ &= A_{ij} B_{hk} \text{tr}[(\mathbf{e}_i \otimes \mathbf{e}_j)^\top (\mathbf{e}_h \otimes \mathbf{e}_k)] = A_{ij} B_{hk} \text{tr}[(\mathbf{e}_j \otimes \mathbf{e}_i)(\mathbf{e}_h \otimes \mathbf{e}_k)] \\ &= A_{ij} B_{hk} \text{tr}[\mathbf{e}_i \cdot \mathbf{e}_h (\mathbf{e}_j \otimes \mathbf{e}_k)] = A_{ij} B_{hk} \mathbf{e}_i \cdot \mathbf{e}_h \mathbf{e}_j \cdot \mathbf{e}_k \\ &= A_{ij} B_{hk} \delta_{ih} \delta_{jk} = A_{ij} B_{ij}. \end{aligned}$$

Like in the case of vectors, the scalar product of two tensors is equal to the sum of the products of the corresponding components. In the same manner, it is easily shown that, $\forall \mathbf{a}, \mathbf{b}, \mathbf{c}, \mathbf{d} \in \mathcal{V}$,

$$(\mathbf{a} \otimes \mathbf{b}) \cdot (\mathbf{c} \otimes \mathbf{d}) = \mathbf{a} \cdot \mathbf{c} \mathbf{b} \cdot \mathbf{d} = a_i b_j c_i d_j,$$

while by the same definition of tensor scalar product,

$$\text{tr} \mathbf{L} = \mathbf{I} \cdot \mathbf{L} \quad \forall \mathbf{L} \in \text{Lin}(\mathcal{V}).$$

Similarly to vectors, we define *Euclidean norm* of a tensor \mathbf{L} the nonnegative scalar, denoted either by L or $|\mathbf{L}|$,

$$L = |\mathbf{L}| = \sqrt{\mathbf{L} \cdot \mathbf{L}} = \sqrt{\text{tr}(\mathbf{L}^\top \mathbf{L})} = \sqrt{L_{ij} L_{ij}},$$

and the *distance* $d(\mathbf{L}, \mathbf{M})$ of two tensors \mathbf{L} and \mathbf{M} the norm of the tensor difference:

$$d(\mathbf{L}, \mathbf{M}) = |\mathbf{L} - \mathbf{M}| = |\mathbf{M} - \mathbf{L}|.$$

2.6 Spherical and deviatoric parts

Let $\mathbf{L} \in \text{Sym}(\mathcal{V})$; the *spherical part* of \mathbf{L} is defined by

$$\mathbf{L}^{sph} = \frac{1}{3} \text{tr} \mathbf{L} \mathbf{I},$$

and the *deviatoric part* by

$$\mathbf{L}^{dev} = \mathbf{L} - \mathbf{L}^{sph},$$

so that

$$\mathbf{L} = \mathbf{L}^{sph} + \mathbf{L}^{dev}.$$

To remark that

$$\text{tr} \mathbf{L}^{sph} = \frac{1}{3} \text{tr} \mathbf{L} \text{tr} \mathbf{I} = \text{tr} \mathbf{L} \Rightarrow \text{tr} \mathbf{L}^{dev} = 0,$$

i.e. the deviatoric part is a traceless tensor. Let $\mathbf{A}, \mathbf{B} \in \text{Lin}(\mathcal{V})$; then

$$\mathbf{A}^{sph} \cdot \mathbf{B}^{dev} = \frac{1}{3} \text{tr} \mathbf{A} \mathbf{I} \cdot \mathbf{B}^{dev} = \frac{1}{3} \text{tr} \mathbf{A} \text{tr} \mathbf{B}^{dev} = 0, \quad (2.6)$$

i.e. any spherical tensor is orthogonal to any deviatoric tensor.

The sets

$$\begin{aligned} Sph(\mathcal{V}) &:= \left\{ \mathbf{A}^{sph} \in \text{Lin}(\mathcal{V}) \mid \mathbf{A}^{sph} = \frac{1}{3} \text{tr} \mathbf{A} \mathbf{I} \quad \forall \mathbf{A} \in \text{Lin}(\mathcal{V}) \right\}, \\ Dev(\mathcal{V}) &:= \left\{ \mathbf{A}^{dev} \in \text{Lin}(\mathcal{V}) \mid \mathbf{A}^{dev} = \mathbf{A} - \mathbf{A}^{sph} \quad \forall \mathbf{A} \in \text{Lin}(\mathcal{V}) \right\} \end{aligned}$$

form two subspaces of $\text{Lin}(\mathcal{V})$; the proof is left to the reader. For what proved above, $Sph(\mathcal{V})$ and $Dev(\mathcal{V})$ are two mutually orthogonal subspaces of $\text{Lin}(\mathcal{V})$.

2.7 Determinant, inverse of a tensor

The reader is probably familiar with the concept of determinant of a matrix. We show here that the determinant of a second rank tensor can be defined intrinsically and that it corresponds with the determinant of the matrix that represents it in any basis of \mathcal{V} . To this purpose, we need first to introduce a mapping:

$$\omega : \mathcal{V} \times \mathcal{V} \times \mathcal{V} \rightarrow \mathbb{R}$$

is a *skew trilinear form* if $\omega(\mathbf{u}, \mathbf{v}, \cdot)$, $\omega(\mathbf{u}, \cdot, \mathbf{v})$ and $\omega(\cdot, \mathbf{u}, \mathbf{v})$ are linear forms on \mathcal{V} and if

$$\omega(\mathbf{u}, \mathbf{v}, \mathbf{w}) = -\omega(\mathbf{v}, \mathbf{u}, \mathbf{w}) = -\omega(\mathbf{u}, \mathbf{w}, \mathbf{v}) = -\omega(\mathbf{w}, \mathbf{v}, \mathbf{u}) \quad \forall \mathbf{u}, \mathbf{v}, \mathbf{w} \in \mathcal{V}. \quad (2.7)$$

After this definition, we can state the following

Theorem 1. *Three vectors are linearly independent if and only if every skew trilinear form on them is not null.*

Proof. In fact, be $\mathbf{u} = \alpha\mathbf{v} + \beta\mathbf{w}$; then, for any skew trilinear form ω ,

$$\omega(\mathbf{u}, \mathbf{v}, \mathbf{w}) = \omega(\alpha\mathbf{v} + \beta\mathbf{w}, \mathbf{v}, \mathbf{w}) = \alpha\omega(\mathbf{v}, \mathbf{v}, \mathbf{w}) + \beta\omega(\mathbf{w}, \mathbf{v}, \mathbf{w}) = 0$$

because of eq. (2.7), applied to the permutation of the positions of the two \mathbf{u} and the two \mathbf{w} . □

It is evident that the set of all the skew trilinear forms is a vector space, that we denote by Ω , whose null element is the *null form* ω_0 :

$$\omega_0(\mathbf{u}, \mathbf{v}, \mathbf{w}) = 0 \quad \forall \mathbf{u}, \mathbf{v}, \mathbf{w} \in \mathcal{V}.$$

For a given $\omega(\mathbf{u}, \mathbf{v}, \mathbf{w}) \in \Omega$, any $\mathbf{L} \in \text{Lin}(\mathcal{V})$ induces another form $\omega_L(\mathbf{u}, \mathbf{v}, \mathbf{w}) \in \Omega$, defined as

$$\omega_L(\mathbf{u}, \mathbf{v}, \mathbf{w}) = \omega(\mathbf{L}\mathbf{u}, \mathbf{L}\mathbf{v}, \mathbf{L}\mathbf{w}) \quad \forall \mathbf{u}, \mathbf{v}, \mathbf{w} \in \mathcal{V}.$$

A key point³ for the following developments is that $\dim \Omega = 1$.

This means that $\forall \omega_1, \omega_2 \neq \omega_0 \in \Omega, \exists \lambda \in \mathbb{R}$ such that

$$\omega_2(\mathbf{u}, \mathbf{v}, \mathbf{w}) = \lambda\omega_1(\mathbf{u}, \mathbf{v}, \mathbf{w}) \quad \forall \mathbf{u}, \mathbf{v}, \mathbf{w} \in \mathcal{V}.$$

So, $\forall \mathbf{L} \in \text{Lin}(\mathcal{V})$, it must exist $\lambda_L \in \mathbb{R}$ such that

$$\omega(\mathbf{L}\mathbf{u}, \mathbf{L}\mathbf{v}, \mathbf{L}\mathbf{w}) = \omega_L(\mathbf{u}, \mathbf{v}, \mathbf{w}) = \lambda_L \omega(\mathbf{u}, \mathbf{v}, \mathbf{w}) \quad \forall \mathbf{u}, \mathbf{v}, \mathbf{w} \in \mathcal{V}. \quad (2.8)$$

³The proof of this statement is rather articulated and out of our scope; the interested reader is addressed to the classical textbook of Halmos on linear algebra, §31 (see the bibliography). The theory of the determinants is developed in §53.

The scalar⁴ λ_L is the *determinant of \mathbf{L}* and in the following it will be denoted as $\det \mathbf{L}$. The determinant of a tensor \mathbf{L} is an intrinsic quantity of \mathbf{L} , i.e. it does not depend upon the particular form ω , nor on the basis of \mathcal{V} . In fact, we have never introduced, so far, a basis for defining $\det \mathbf{L}$, hence it cannot depend upon the choice of a basis for \mathcal{V} , i.e. $\det \mathbf{L}$ is a *tensor invariant*.

Then, if ω^1 and $\omega^2 \in \Omega$, because $\dim \Omega = 1$, it exists $k \in \mathbb{R}$, $k \neq 0$ such that

$$\begin{aligned}\omega^2(\mathbf{u}, \mathbf{v}, \mathbf{w}) &= k \omega^1(\mathbf{u}, \mathbf{v}, \mathbf{w}) \quad \forall \mathbf{u}, \mathbf{v}, \mathbf{w} \in \mathcal{V} \Rightarrow \\ \omega^2(\mathbf{L}\mathbf{u}, \mathbf{L}\mathbf{v}, \mathbf{L}\mathbf{w}) &= k \omega^1(\mathbf{L}\mathbf{u}, \mathbf{L}\mathbf{v}, \mathbf{L}\mathbf{w}) \rightarrow \\ \omega_L^2(\mathbf{u}, \mathbf{v}, \mathbf{w}) &= k \omega_L^1(\mathbf{u}, \mathbf{v}, \mathbf{w}).\end{aligned}$$

Moreover, by eq. (2.8) we get

$$\begin{aligned}\omega^1(\mathbf{L}\mathbf{u}, \mathbf{L}\mathbf{v}, \mathbf{L}\mathbf{w}) &= \omega_L^1(\mathbf{u}, \mathbf{v}, \mathbf{w}) = \lambda_L^1 \omega^1(\mathbf{u}, \mathbf{v}, \mathbf{w}), \\ \omega^2(\mathbf{L}\mathbf{u}, \mathbf{L}\mathbf{v}, \mathbf{L}\mathbf{w}) &= \omega_L^2(\mathbf{u}, \mathbf{v}, \mathbf{w}) = \lambda_L^2 \omega^2(\mathbf{u}, \mathbf{v}, \mathbf{w}),\end{aligned}$$

so that

$$\begin{aligned}\lambda_L^2 k \omega^1(\mathbf{u}, \mathbf{v}, \mathbf{w}) &= \lambda_L^2 \omega^2(\mathbf{u}, \mathbf{v}, \mathbf{w}) = \omega_L^2(\mathbf{u}, \mathbf{v}, \mathbf{w}) = \\ k \omega_L^1(\mathbf{u}, \mathbf{v}, \mathbf{w}) &= \lambda_L^1 k \omega^1(\mathbf{u}, \mathbf{v}, \mathbf{w}) \iff \lambda_L^1 = \lambda_L^2,\end{aligned}$$

which proves that $\det \mathbf{L}$ does not depend upon the skew trilinear form, but only upon \mathbf{L} .

The definition given for $\det \mathbf{L}$ let us prove some important properties. First of all,

$$\det \mathbf{O} = 0;$$

in fact, $\forall \omega \in \Omega$,

$$\det \mathbf{O} \omega(\mathbf{u}, \mathbf{v}, \mathbf{w}) = \omega(\mathbf{O}\mathbf{u}, \mathbf{O}\mathbf{v}, \mathbf{O}\mathbf{w}) = \omega(\mathbf{o}, \mathbf{o}, \mathbf{o}) = 0$$

because ω operates on three identical, i.e. linearly dependent, vectors. Then, if $\mathbf{L} = \mathbf{I}$,

$$\det \mathbf{I} \omega(\mathbf{u}, \mathbf{v}, \mathbf{w}) = \omega(\mathbf{I}\mathbf{u}, \mathbf{I}\mathbf{v}, \mathbf{I}\mathbf{w}) = \omega(\mathbf{u}, \mathbf{v}, \mathbf{w})$$

if and only if

$$\det \mathbf{I} = 1. \tag{2.9}$$

A third property is that $\forall \mathbf{a}, \mathbf{b} \in \mathcal{V}$,

$$\det(\mathbf{a} \otimes \mathbf{b}) = 0. \tag{2.10}$$

In fact, if $\mathbf{L} = \mathbf{a} \otimes \mathbf{b}$, then

$$\det \mathbf{L} \omega(\mathbf{u}, \mathbf{v}, \mathbf{w}) = \omega(\mathbf{L}\mathbf{u}, \mathbf{L}\mathbf{v}, \mathbf{L}\mathbf{w}) = \omega((\mathbf{b} \cdot \mathbf{u})\mathbf{a}, (\mathbf{b} \cdot \mathbf{v})\mathbf{a}, (\mathbf{b} \cdot \mathbf{w})\mathbf{a}) = 0$$

because the three vectors on which $\omega \in \Omega$ operates are linearly dependent; being \mathbf{u}, \mathbf{v} and \mathbf{w} arbitrary, this implies eq. (2.10).

An important result is the

⁴More precisely, $\det \mathbf{L}$ is the function that associates a scalar with each tensor (Halmos, §53). We can however, for the sake of practice, identify $\det \mathbf{L}$ with the scalar associated to \mathbf{L} , without consequences for our purposes.

Theorem 2. (*Theorem of Binet*): $\forall \mathbf{A}, \mathbf{B} \in \text{Lin}(\mathcal{V})$

$$\det(\mathbf{AB}) = \det \mathbf{A} \det \mathbf{B}. \quad (2.11)$$

Proof. $\forall \omega \in \Omega$,

$$\begin{aligned} \lambda_{AB}\omega(\mathbf{u}, \mathbf{v}, \mathbf{w}) &= \omega(\mathbf{ABu}, \mathbf{ABv}, \mathbf{ABw}) = \omega(\mathbf{A}(\mathbf{Bu}), \mathbf{A}(\mathbf{Bv}), \mathbf{A}(\mathbf{Bw})) = \\ \lambda_A\omega(\mathbf{Bu}, \mathbf{Bv}, \mathbf{Bw}) &= \lambda_A\lambda_B\omega(\mathbf{u}, \mathbf{v}, \mathbf{w}) \iff \lambda_{AB} = \lambda_A\lambda_B, \end{aligned}$$

which proves the theorem. \square

A tensor \mathbf{L} is called *singular* if $\det \mathbf{L} = 0$, otherwise it is *non-singular*.

Considering eq. (2.8), one can easily see that, if in a basis \mathcal{B} of \mathcal{V} it is $\mathbf{L} = L_{ij}\mathbf{e}_i \otimes \mathbf{e}_j$, then

$$\det \mathbf{L} = \sum_{\pi \in \mathcal{P}_3} \epsilon_{\pi(1), \pi(2), \pi(3)} L_{1, \pi(1)} L_{2, \pi(2)} L_{3, \pi(3)},$$

where \mathcal{P}_3 is the set of all the permutations π of $\{1, 2, 3\}$ and the $\epsilon_{i,j,k}$ s are the components of the *Ricci alternator*:

$$\epsilon_{i,j,k} = \begin{cases} 1 & \text{if } (i, j, k) \text{ is an even permutation of } (1, 2, 3), \\ 0 & \text{if } (i, j, k) \text{ is not a permutation,} \\ -1 & \text{if } (i, j, k) \text{ is an odd permutation of } (1, 2, 3). \end{cases}$$

The above rule for $\det \mathbf{L}$ coincides with that for calculating the determinant of the matrix whose entries are the L_{ij} s. This shows that, once chosen a basis \mathcal{B} for \mathcal{V} , $\det \mathbf{L}$ coincides with the determinant of the matrix representing it in \mathcal{B} , and finally that

$$\begin{aligned} \det \mathbf{L} &= L_{11}L_{22}L_{33} + L_{12}L_{23}L_{31} + L_{13}L_{32}L_{21} \\ &\quad - L_{11}L_{23}L_{32} - L_{22}L_{13}L_{31} - L_{33}L_{12}L_{21}. \end{aligned} \quad (2.12)$$

This result shows immediately that $\forall \mathbf{L} \in \text{Lin}(\mathcal{V})$, and regardless of \mathcal{B} , it is

$$\det \mathbf{L}^\top = \det \mathbf{L}. \quad (2.13)$$

Using eq. (2.12), it is not difficult to show that, $\forall \alpha \in \mathbb{R}$,

$$\det(\mathbf{I} + \alpha\mathbf{L}) = 1 + \alpha I_1 + \alpha^2 I_2 + \alpha^3 I_3, \quad (2.14)$$

where I_1, I_2 and I_3 are the three *principal invariants* of \mathbf{L} :

$$I_1 = \text{tr} \mathbf{L}, \quad I_2 = \frac{\text{tr}^2 \mathbf{L} - \text{tr} \mathbf{L}^2}{2}, \quad I_3 = \det \mathbf{L}. \quad (2.15)$$

A tensor $\mathbf{L} \in \text{Lin}(\mathcal{V})$ is said to be *invertible* if there is a tensor $\mathbf{L}^{-1} \in \text{Lin}(\mathcal{V})$, called the *inverse* of \mathbf{L} , such that

$$\mathbf{L}\mathbf{L}^{-1} = \mathbf{L}^{-1}\mathbf{L} = \mathbf{I}. \quad (2.16)$$

If \mathbf{L} is invertible, then \mathbf{L}^{-1} is unique. By the above definition, if \mathbf{L} is invertible, then

$$\mathbf{u}_1 = \mathbf{L}\mathbf{u} \Rightarrow \mathbf{u} = \mathbf{L}^{-1}\mathbf{u}_1.$$

Theorem 3. *Any invertible tensor maps triples of linearly independent vectors into triples of still linearly independent vectors.*

Proof. Be \mathbf{L} an invertible tensor and $\mathbf{u}_1 = \mathbf{L}\mathbf{u}$, $\mathbf{v}_1 = \mathbf{L}\mathbf{v}$, $\mathbf{w}_1 = \mathbf{L}\mathbf{w}$, where \mathbf{u} , \mathbf{v} , \mathbf{w} are three linearly independent vectors. Let us suppose that

$$\mathbf{u}_1 = h\mathbf{v}_1 + k\mathbf{w}_1, \quad h, k \in \mathbb{R}.$$

Then, because \mathbf{L} is invertible,

$$\mathbf{L}^{-1}\mathbf{u}_1 = \mathbf{L}^{-1}(h\mathbf{v}_1 + k\mathbf{w}_1) = h\mathbf{L}^{-1}\mathbf{v}_1 + k\mathbf{L}^{-1}\mathbf{w}_1 = h\mathbf{v} + k\mathbf{w},$$

which goes against the hypothesis. By consequence, \mathbf{u}_1 , \mathbf{v}_1 and \mathbf{w}_1 are linearly independent. \square

This result, along with the definition of determinant, eq. (2.8), and Theorem 1, proves the

Theorem 4. (*Invertibility theorem*): $\mathbf{L} \in \text{Lin}(\mathcal{V})$ is invertible $\iff \det \mathbf{L} \neq 0$.

Using the Theorem of Binet, 2, along with eqs. (2.9) and (2.16), we get

$$\det \mathbf{L}^{-1} = \frac{1}{\det \mathbf{L}}.$$

Equation (2.16) applied to \mathbf{L}^{-1} , along with the uniqueness of the inverse, gives immediately that

$$(\mathbf{L}^{-1})^{-1} = \mathbf{L},$$

while

$$\mathbf{B}^{-1}\mathbf{A}^{-1} = \mathbf{B}^{-1}\mathbf{A}^{-1}\mathbf{A}\mathbf{B}(\mathbf{A}\mathbf{B})^{-1} = (\mathbf{A}\mathbf{B})^{-1}.$$

The operations of transpose and inversion commute:

$$\begin{aligned} \mathbf{L}^\top(\mathbf{L}^\top)^{-1} &= \mathbf{I} = \mathbf{L}^{-1}\mathbf{L} = \mathbf{I}^\top = (\mathbf{L}^{-1}\mathbf{L})^\top = \mathbf{L}^\top(\mathbf{L}^{-1})^\top \Rightarrow \\ (\mathbf{L}^{-1})^\top &= (\mathbf{L}^\top)^{-1} := \mathbf{L}^{-\top}. \end{aligned}$$

2.8 Eigenvalues and eigenvectors of a tensor

If it exists a $\lambda \in \mathbb{R}$ and a $\mathbf{v} \in \mathcal{V}$, except the null vector, such that

$$\mathbf{L}\mathbf{v} = \lambda\mathbf{v}, \tag{2.17}$$

then λ is an *eigenvalue* and \mathbf{v} an *eigenvector*, relatif to λ , of \mathbf{L} . It is immediate to observe that, thanks to linearity, any eigenvector \mathbf{v} of \mathbf{L} is determined to within a multiplier, i.e., that $k\mathbf{v}$ is an eigenvector of \mathbf{L} too, $\forall k \in \mathbb{R}$. Often, the multiplier k is fixed in such a way that $|\mathbf{v}| = 1$.

To determine the eigenvalues and eigenvectors of a tensor, we rewrite eq. (2.17) as

$$(\mathbf{L} - \lambda \mathbf{I})\mathbf{v} = \mathbf{o}. \quad (2.18)$$

The condition for this homogeneous system have a non null solution is

$$\det(\mathbf{L} - \lambda \mathbf{I}) = 0;$$

this is the so-called *characteristic* or *Laplace's equation*. In the case of a second rank tensor over \mathcal{V} , the Laplace's equation is an algebraic equation of degree 3 with real coefficients. The roots of the Laplace's equation are the eigenvalues of \mathbf{L} ; because the components of \mathbf{L} , and hence the coefficients of the characteristic equation, are all real, then the eigenvalues of \mathbf{L} are all real or one real and two complex conjugate.

For any eigenvalue λ_i , $i = 1, 2, 3$ of \mathbf{L} , the corresponding eigenvectors \mathbf{v}_i can be found solving eq. (2.18), once put $\lambda = \lambda_i$.

The *proper space* of \mathbf{L} relatif to λ is the subspace of $Lin(\mathcal{V})$ composed by all the vectors that satisfy eq. (2.18). The *multiplicity* of λ is the dimension of its proper space, while the *spectrum* of \mathbf{L} is the set composed by all of its eigenvalues, each one with its multiplicity.

\mathbf{L}^\top has the same eigenvalues of \mathbf{L} , because the Laplace's equation is the same in both the cases:

$$\det(\mathbf{L}^\top - \lambda \mathbf{I}) = \det(\mathbf{L}^\top - \lambda \mathbf{I}^\top) = \det(\mathbf{L} - \lambda \mathbf{I})^\top = \det(\mathbf{L} - \lambda \mathbf{I}).$$

However, this is not the case for the eigenvectors, that, generally speaking, are different, as a simple example can show.

Developing the Laplace's equation, it is easy to show that it can be written as

$$\det(\mathbf{L} - \lambda \mathbf{I}) = -\lambda^3 + I_1\lambda^2 - I_2\lambda + I_3 = 0,$$

which is merely an application of eq. (2.14). If we denote $\mathbf{L}^3 = \mathbf{L}\mathbf{L}\mathbf{L}$, using eq. (2.15) one can prove the

Theorem 5. (*Cayley-Hamilton Theorem*): $\forall \mathbf{L} \in Lin(\mathcal{V})$,

$$\mathbf{L}^3 - I_1\mathbf{L}^2 + I_2\mathbf{L} - I_3\mathbf{I} = \mathbf{O}.$$

A *quadratic form* defined by \mathbf{L} is any form $\omega : \mathcal{V} \times \mathcal{V} \rightarrow \mathbb{R}$ of the type

$$\omega = \mathbf{v} \cdot \mathbf{L}\mathbf{v};$$

if $\omega > 0 \forall \mathbf{v} \in \mathcal{V}$, $\omega = 0 \iff \mathbf{v} = \mathbf{o}$, then ω and \mathbf{L} are said to be *positive definite*. The eigenvalues of a positive definite tensor are positive. In fact, if λ is an eigenvalue of \mathbf{L} , positive definite, and \mathbf{v} its eigenvector, then

$$\mathbf{v} \cdot \mathbf{L}\mathbf{v} = \mathbf{v} \cdot \lambda \mathbf{v} = \lambda \mathbf{v}^2 > 0 \iff \lambda > 0.$$

Be \mathbf{v}_1 and \mathbf{v}_2 two eigenvectors of a symmetric tensor \mathbf{L} relative to the eigenvalues λ_1 and λ_2 , respectively, with $\lambda_1 \neq \lambda_2$; then

$$\lambda_1 \mathbf{v}_1 \cdot \mathbf{v}_2 = \mathbf{L} \mathbf{v}_1 \cdot \mathbf{v}_2 = \mathbf{L} \mathbf{v}_2 \cdot \mathbf{v}_1 = \lambda_2 \mathbf{v}_2 \cdot \mathbf{v}_1 \iff \mathbf{v}_1 \cdot \mathbf{v}_2 = 0.$$

Actually, symmetric tensors have a particular importance, specified by the

Theorem 6. (*Spectral Theorem*): *the eigenvectors of a symmetric tensor form a basis of \mathcal{V} .*

This theorem⁵ is of the paramount importance in linear algebra: it proves that the eigenvalues of a symmetric tensor \mathbf{L} are real valued and, remembering the definition of eigenvalues and eigenvectors, eq. (2.17), that it exists a basis $\mathcal{B}_N = \{\mathbf{u}_1, \mathbf{u}_2, \mathbf{u}_3\}$ of \mathcal{V} composed by eigenvectors of \mathbf{L} , i.e. by vectors that are mutually orthogonal and that remain mutually orthogonal once transformed by \mathbf{L} . Such a basis is called the *normal basis*.

If $\lambda_i, i = 1, 2, 3$, are the eigenvalues of \mathbf{L} , then the components of \mathbf{L} in \mathcal{B}_N are

$$L_{ij} = \mathbf{u}_i \cdot \mathbf{L} \mathbf{u}_j = \mathbf{u}_i \cdot \lambda_j \mathbf{u}_j = \lambda_j \delta_{ij}$$

so finally in \mathcal{B}_N it is

$$\mathbf{L} = \lambda_i \mathbf{e}_i \otimes \mathbf{e}_i,$$

i.e. \mathbf{L} is diagonal and is completely represented by its eigenvalues. In addition, it is easy to check that

$$I_1 = \lambda_1 + \lambda_2 + \lambda_3, \quad I_2 = \lambda_1 \lambda_2 + \lambda_2 \lambda_3 + \lambda_3 \lambda_1, \quad I_3 = \lambda_1 \lambda_2 \lambda_3.$$

A tensor with a unique eigenvalue λ , of multiplicity 3, is said to be *spherical*; in such a case, any basis of \mathcal{V} is \mathcal{B}_N and

$$\mathbf{L} = \lambda \mathbf{I}.$$

Eigenvalues and eigenvectors have also another important property: let us consider the quadratic form $\omega := \mathbf{v} \cdot \mathbf{L} \mathbf{v}$, $\forall \mathbf{v} \in \mathcal{S}$, defined by a symmetric tensor \mathbf{L} . We look for the directions $\mathbf{v} \in \mathcal{S}$ whereupon ω is stationary. Then, we have to solve the constrained problem

$$\nabla_{\mathbf{v}}(\mathbf{v} \cdot \mathbf{L} \mathbf{v}) = \mathbf{o}, \quad \mathbf{v} \in \mathcal{S}.$$

Using the Lagrange's multiplier technique, we solve the equivalent problem

$$\nabla_{(\mathbf{v}, \lambda)}(\mathbf{v} \cdot \mathbf{L} \mathbf{v} - \lambda(\mathbf{v}^2 - 1)) = 0,$$

which restitutes the equation

$$\mathbf{L} \mathbf{v} = \lambda \mathbf{v}$$

and the constraint $|\mathbf{v}| = 1$. The above equation is exactly the one defining the eigenvalue problem for \mathbf{L} : the stationary values (i.e. the maximum and minimum) of ω corresponds

⁵The proof of the spectral theorem is omitted here; the interested reader can find a proof of it in the classical text of Halmos, page 155, see the bibliography.

hence to two eigenvalues of \mathbf{L} and the directions \mathbf{v} whereupon stationarity is get coincide with the respective eigenvectors.

Two tensors \mathbf{A} and \mathbf{B} are said to be *coaxial* if they have the same normal basis \mathcal{B}_N , i.e. if they share the same eigenvectors. Be \mathbf{u} an eigenvector of \mathbf{A} , relative to the eigenvalue λ_A , and of \mathbf{B} , relatif to λ_B . Then,

$$\mathbf{A}\mathbf{B}\mathbf{u} = \mathbf{A}\lambda_B\mathbf{u} = \lambda_B\mathbf{A}\mathbf{u} = \lambda_A\lambda_B\mathbf{u} = \lambda_A\mathbf{B}\mathbf{u} = \mathbf{B}\lambda_A\mathbf{u} = \mathbf{B}\mathbf{A}\mathbf{u},$$

which shows, on one hand, that also $\mathbf{B}\mathbf{u}$ is an eigenvector of \mathbf{A} , relative to the same eigenvalue λ_A ; in the same way, of course, $\mathbf{A}\mathbf{u}$ is an eigenvector of \mathbf{B} relative to λ_B . In other words, this shows that \mathbf{B} leaves unchanged any proper space of \mathbf{A} , and viceversa. On the other hand, we see that, at least for what concerns the eigenvectors, two tensors commute if and only if they are coaxial. Because any vector can be written as a linear combination of the vectors of \mathcal{B}_N , and for the linearity of tensors, we finally have proved the

Theorem 7. (*Commutation Theorem*): *two tensors commute if and only if they are coaxial.*

2.9 Skew tensors and cross product

Because $\dim(\mathcal{V}) = \dim(\text{Skw}(\mathcal{V})) = 3$, an isomorphism can be established between \mathcal{V} and $\text{Skw}(\mathcal{V})$, i.e. between vectors and skew tensors. We establish hence a way to associate in a unique way a vector to any skew tensor and inversely. To this purpose, we first introduce the following

Theorem 8. *The spectrum of any tensor $\mathbf{W} \in \text{Skw}(\mathcal{V})$ is $\{0\}$ and the dimension of its proper space is 1.*

Proof. This theorem states that zero is the only real eigenvalue of any skew tensor and that its multiplicity is 1. In fact, be \mathbf{w} an eigenvector of \mathbf{W} relative to the eigenvalue λ . Then

$$\begin{aligned} \lambda^2\mathbf{w}^2 &= \mathbf{W}\mathbf{w} \cdot \mathbf{W}\mathbf{w} = \mathbf{w} \cdot \mathbf{W}^\top \mathbf{W}\mathbf{w} = -\mathbf{w} \cdot \mathbf{W}\mathbf{W}\mathbf{w} \\ &= -\mathbf{w} \cdot \mathbf{W}(\lambda\mathbf{w}) = -\lambda\mathbf{w} \cdot \mathbf{W}\mathbf{w} = -\lambda^2\mathbf{w}^2 \iff \lambda = 0. \end{aligned}$$

Then, if $\mathbf{W} \neq \mathbf{O}$ its rank is necessarily 2, because $\det \mathbf{W} = 0 \forall \mathbf{W} \in \text{Skw}(\mathcal{V})$; hence, the equation

$$\mathbf{W}\mathbf{w} = \mathbf{o} \tag{2.19}$$

has ∞^1 solutions, i.e. the multiplicity of λ is 1, which proves the theorem. \square

The last equation gives also the way the isomorphism is constructed: in fact, using eq. (2.19) it is easy to check that if $\mathbf{w} = (a, b, c)$, then

$$\mathbf{w} = (a, b, c) \iff \mathbf{W} = \begin{bmatrix} 0 & -c & b \\ c & 0 & -a \\ -b & a & 0 \end{bmatrix}. \tag{2.20}$$

The proper space of \mathbf{W} is called the *axis of \mathbf{W}* and it is indicated by $\mathcal{A}(\mathbf{W})$:

$$\mathcal{A}(\mathbf{W}) = \{\mathbf{u} \in \mathcal{V} \mid \mathbf{W}\mathbf{u} = \mathbf{o}\}.$$

The consequence of what shown above is that $\dim \mathcal{A}(\mathbf{W}) = 1$. With regard to eq. (2.20), one can check easily that the equation

$$\mathbf{u} \cdot \mathbf{u} = \frac{1}{2} \mathbf{W} \cdot \mathbf{W} \quad (2.21)$$

is satisfied only by \mathbf{w} and by its opposite $-\mathbf{w}$. Because both these vectors belong to $\mathcal{A}(\mathbf{W})$, choosing one of them corresponds to choose an orientation for \mathcal{E} , see below. We will always fix our choice according to eq. (2.20), which fixes once and for all the isomorphism between \mathcal{V} and $Skw(\mathcal{V})$ that makes correspond any vector \mathbf{w} with one and only one *axial tensor* \mathbf{W} and vice-versa, any skew tensor \mathbf{W} with a unique *axial vector* \mathbf{w} .

It is worth noting that the above isomorphism between the vector spaces \mathcal{V} and $Skw(\mathcal{V})$ implies that to any linear combination of vectors \mathbf{a} and \mathbf{b} corresponds an equal linear combination of the corresponding axial tensors \mathbf{W}_a and \mathbf{W}_b and vice-versa, i.e. $\forall a, b \in \mathbb{R}$

$$\mathbf{w} = \alpha \mathbf{a} + \beta \mathbf{b} \iff \mathbf{W} = \alpha \mathbf{W}_a + \beta \mathbf{W}_b, \quad (2.22)$$

where \mathbf{W} is the axial tensor of \mathbf{w} . Such a property is immediately checked using eq. (2.20).

It is useful, for further developments, to calculate the powers of \mathbf{W} :

$$\mathbf{W}^2 = \mathbf{W}\mathbf{W} = -\mathbf{W}^\top(-\mathbf{W}^\top) = (\mathbf{W}\mathbf{W})^\top = (\mathbf{W}^2)^\top \quad (2.23)$$

i.e. \mathbf{W}^2 is symmetric. Moreover:

$$\begin{aligned} \mathbf{W}^2 \mathbf{u} &= \mathbf{W}\mathbf{W}\mathbf{u} = \mathbf{w} \times (\mathbf{w} \times \mathbf{u}) = \mathbf{w} \cdot \mathbf{u}\mathbf{w} - \mathbf{w} \cdot \mathbf{w}\mathbf{u} \\ &= -(\mathbf{I} - \mathbf{w} \otimes \mathbf{w})\mathbf{u} \Rightarrow \mathbf{W}^2 = -(\mathbf{I} - \mathbf{w} \otimes \mathbf{w}) \end{aligned} \quad (2.24)$$

So, applying recursively the previous results,

$$\begin{aligned} \mathbf{W}^3 &= \mathbf{W}\mathbf{W}^2 = -\mathbf{W}(\mathbf{I} - \mathbf{w} \otimes \mathbf{w}) = -\mathbf{W} + (\mathbf{W}\mathbf{w}) \otimes \mathbf{w} = -\mathbf{W} \\ \mathbf{W}^4 &= \mathbf{W}\mathbf{W}^3 = -\mathbf{W}^2 \\ \mathbf{W}^5 &= \mathbf{W}\mathbf{W}^4 = -\mathbf{W}^3 \end{aligned} \quad (2.25)$$

etc.

An important property of any couple axial tensor \mathbf{W} - axial vector \mathbf{w} is

$$\mathbf{W}\mathbf{W} = -\frac{1}{2} |\mathbf{W}|^2 (\mathbf{I} - \mathbf{w} \otimes \mathbf{w}),$$

while eq. (2.21) can be generalized to any two axial couples $\mathbf{w}_1, \mathbf{W}_1$ and $\mathbf{w}_2, \mathbf{W}_2$:

$$\mathbf{w}_1 \cdot \mathbf{w}_2 = \frac{1}{2} \mathbf{W}_1 \cdot \mathbf{W}_2.$$

The proof of these two last properties is rather easy and left to the reader.

We define *cross product* of two vectors \mathbf{a} and \mathbf{b} the vector

$$\mathbf{a} \times \mathbf{b} = \mathbf{W}_a \mathbf{b},$$

where \mathbf{W}_a is the axial tensor of \mathbf{a} . If $\mathbf{a} = (a_1, a_2, a_3)$ and $\mathbf{b} = (b_1, b_2, b_3)$, then by eq. (2.20) we get

$$\mathbf{a} \times \mathbf{b} = (a_2 b_3 - a_3 b_2, a_3 b_1 - a_1 b_3, a_1 b_2 - a_2 b_1).$$

The cross product is bilinear: $\forall \mathbf{a}, \mathbf{b}, \mathbf{u} \in \mathcal{V}, \alpha, \beta \in \mathbb{R}$,

$$\begin{aligned} (\alpha \mathbf{a} + \beta \mathbf{b}) \times \mathbf{u} &= \alpha \mathbf{a} \times \mathbf{u} + \beta \mathbf{b} \times \mathbf{u}, \\ \mathbf{u} \times (\alpha \mathbf{a} + \beta \mathbf{b}) &= \alpha \mathbf{u} \times \mathbf{a} + \beta \mathbf{u} \times \mathbf{b}. \end{aligned}$$

In fact, the first equation above is a consequence of eq. (2.22), while the second one is a simple application to axial tensors of the same definition of tensor.

Three important results concerning the cross product are stated by the following theorems:

Theorem 9. (*Condition of parallelism*): two vectors \mathbf{a} and \mathbf{b} are parallel, i.e. $\mathbf{b} = k\mathbf{a}$, $k \in \mathbb{R}$, \iff

$$\mathbf{a} \times \mathbf{b} = \mathbf{o}.$$

Proof. This property is actually a consequence of the fact that any eigenvalue of a tensor is determined to within a multiplier:

$$\mathbf{a} \times \mathbf{b} = \mathbf{W}_a \mathbf{b} = \mathbf{o} \iff \mathbf{b} = k\mathbf{a}, k \in \mathbb{R},$$

for Theorem 8. □

Theorem 10. (*Orthogonality property*):

$$\mathbf{a} \times \mathbf{b} \cdot \mathbf{a} = \mathbf{a} \times \mathbf{b} \cdot \mathbf{b} = 0. \tag{2.26}$$

Proof.

$$\begin{aligned} \mathbf{a} \times \mathbf{b} \cdot \mathbf{a} &= \mathbf{W}_a \mathbf{b} \cdot \mathbf{a} = \mathbf{b} \cdot \mathbf{W}_a^\top \mathbf{a} = -\mathbf{b} \cdot \mathbf{W}_a \mathbf{a} = -\mathbf{b} \cdot \mathbf{o} = 0, \\ \mathbf{a} \times \mathbf{b} \cdot \mathbf{b} &= \mathbf{W}_a \mathbf{b} \cdot \mathbf{b} = \mathbf{b} \cdot \mathbf{W}_a^\top \mathbf{b} = -\mathbf{b} \cdot \mathbf{W}_a \mathbf{b} \iff \mathbf{a} \times \mathbf{b} \cdot \mathbf{b} = 0. \end{aligned}$$

□

Theorem 11. $\mathbf{a} \times \mathbf{b}$ is the axial vector of the tensor $(\mathbf{b} \otimes \mathbf{a} - \mathbf{a} \otimes \mathbf{b})$.

Proof. First of all, by eq. (2.5) we see that

$$(\mathbf{b} \otimes \mathbf{a} - \mathbf{a} \otimes \mathbf{b}) \in \text{Skew}(\mathcal{V}).$$

Then,

$$(\mathbf{b} \otimes \mathbf{a} - \mathbf{a} \otimes \mathbf{b})(\mathbf{a} \times \mathbf{b}) = \mathbf{a} \cdot \mathbf{a} \times \mathbf{b} \mathbf{b} - \mathbf{b} \cdot \mathbf{a} \times \mathbf{b} \mathbf{a} = 0$$

for Theorem 10. □

Theorem 11 allows for showing that, unlike the scalar product, the cross product is anti-symmetric:

$$\mathbf{a} \times \mathbf{b} = -\mathbf{b} \times \mathbf{a}. \quad (2.27)$$

In fact, if $\mathbf{W}_1 = (\mathbf{b} \otimes \mathbf{a} - \mathbf{a} \otimes \mathbf{b})$ is the axial tensor of $\mathbf{a} \times \mathbf{b}$, $\mathbf{W}_2 = (-\mathbf{a} \otimes \mathbf{b} + \mathbf{b} \otimes \mathbf{a})$ is that of $-\mathbf{b} \times \mathbf{a}$. But, evidently, $\mathbf{W}_1 = \mathbf{W}_2$ which implies eq. (2.27) for the isomorphism between \mathcal{V} and $\text{Lin}(\mathcal{V})$. This property and again Theorem 11 let us show the formula for the *double cross product*:

$$\mathbf{u} \times (\mathbf{v} \times \mathbf{w}) = -(\mathbf{v} \times \mathbf{w}) \times \mathbf{u} = -(\mathbf{w} \otimes \mathbf{v} - \mathbf{v} \otimes \mathbf{w})\mathbf{u} = \mathbf{u} \cdot \mathbf{w} \mathbf{v} - \mathbf{u} \cdot \mathbf{v} \mathbf{w}. \quad (2.28)$$

Another interesting result concerns the *mixed product*:

$$\mathbf{u} \times \mathbf{v} \cdot \mathbf{w} = \mathbf{W}_u \mathbf{v} \cdot \mathbf{w} = -\mathbf{v} \cdot \mathbf{W}_u \mathbf{w} = -\mathbf{v} \cdot \mathbf{u} \times \mathbf{w} = \mathbf{w} \times \mathbf{u} \cdot \mathbf{v}, \quad (2.29)$$

and similarly

$$\mathbf{u} \times \mathbf{v} \cdot \mathbf{w} = \mathbf{v} \times \mathbf{w} \cdot \mathbf{u}.$$

Using this last result, we can obtain a formula for the norm of a cross product; if $\mathbf{a} = a \mathbf{e}_a$ and $\mathbf{b} = b \mathbf{e}_b$, with $\mathbf{e}_a, \mathbf{e}_b \in \mathcal{S}$, are two vectors forming the angle θ , then

$$\begin{aligned} (\mathbf{a} \times \mathbf{b}) \cdot (\mathbf{a} \times \mathbf{b}) &= \mathbf{a} \times \mathbf{b} \cdot (\mathbf{a} \times \mathbf{b}) = (\mathbf{a} \times \mathbf{b}) \times \mathbf{a} \cdot \mathbf{b} = -\mathbf{a} \times (\mathbf{a} \times \mathbf{b}) \cdot \mathbf{b} = \\ &= (-\mathbf{a} \cdot \mathbf{b} \mathbf{a} + \mathbf{a}^2 \mathbf{b}) \cdot \mathbf{b} = \mathbf{b} \cdot (\mathbf{a}^2 \mathbf{I} - \mathbf{a} \otimes \mathbf{a}) \mathbf{b} = a^2 \mathbf{b} \cdot (\mathbf{I} - \mathbf{e}_a \otimes \mathbf{e}_a) \mathbf{b} = \\ &= a^2 b^2 \mathbf{e}_b \cdot (\mathbf{I} - \mathbf{e}_a \otimes \mathbf{e}_a) \mathbf{e}_b = a^2 b^2 (1 - \cos^2 \theta) = a^2 b^2 \sin^2 \theta \rightarrow |\mathbf{a} \times \mathbf{b}| = ab \sin \theta. \end{aligned}$$

So, the norm of a cross product can be interpreted, geometrically, as the area of the parallelogram spanned by the two vectors. As a consequence, the absolute value of the mixed product (2.29) measures the volume of the prism delimited by three non coplanar vectors.

Because the cross product is antisymmetric and the scalar one is symmetric, it is easy to check that the form

$$\beta(\mathbf{u}, \mathbf{v}, \mathbf{w}) = \mathbf{u} \times \mathbf{v} \cdot \mathbf{w}$$

is a skew trilinear form. Then, eq. (2.8), we get

$$\mathbf{L}\mathbf{u} \times \mathbf{L}\mathbf{v} \cdot \mathbf{L}\mathbf{w} = \det \mathbf{L} \mathbf{u} \times \mathbf{v} \cdot \mathbf{w}. \quad (2.30)$$

Following the interpretation given above for the absolute value of the mixed product, we can conclude that $|\det \mathbf{L}|$ can be interpreted as a coefficient of volume dilation. A geometrical interpretation can then be given to the case of a non invertible tensor, i.e.

of $\det \mathbf{L} = 0$: it crushes a prism into a flat region (the three original vectors become coplanar, i.e. linearly dependent).

The *adjugate* of \mathbf{L} is the tensor

$$\mathbf{L}^* := (\det \mathbf{L})\mathbf{L}^{-\top}.$$

From eq. (2.30) we get hence

$$\begin{aligned} \det \mathbf{L} \mathbf{u} \times \mathbf{v} \cdot \mathbf{w} &= \mathbf{L}\mathbf{u} \times \mathbf{L}\mathbf{v} \cdot \mathbf{L}\mathbf{w} = \mathbf{L}^\top(\mathbf{L}\mathbf{u} \times \mathbf{L}\mathbf{v}) \cdot \mathbf{w} \quad \forall \mathbf{w} \Rightarrow \\ \mathbf{L}\mathbf{u} \times \mathbf{L}\mathbf{v} &= \mathbf{L}^*(\mathbf{u} \times \mathbf{v}). \end{aligned}$$

2.10 Orientation of a basis

It is immediate to observe that a basis $\mathcal{B} = \{\mathbf{e}_1, \mathbf{e}_2, \mathbf{e}_3\}$ can be oriented in two opposite ways⁶: e.g., once two unit mutually orthogonal vectors \mathbf{e}_1 and \mathbf{e}_2 chosen, there are two opposite unit vectors perpendicular to both \mathbf{e}_1 and \mathbf{e}_2 that can be chosen to form \mathcal{B} .

We say that \mathcal{B} is *positively oriented* or *right-handed* if

$$\mathbf{e}_1 \times \mathbf{e}_2 \cdot \mathbf{e}_3 = 1,$$

while \mathcal{B} is *negatively oriented* or *left-handed* if

$$\mathbf{e}_1 \times \mathbf{e}_2 \cdot \mathbf{e}_3 = -1.$$

Schematically, a right-handed basis is represented in Fig. 2.1, where a left-handed basis is represented too, with a dashed \mathbf{e}_3 .

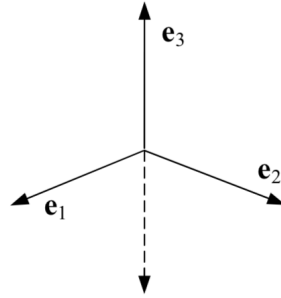

Figure 2.1: Right- and left-handed bases.

With a right-handed basis, by definition the axial tensors of the three vectors of the basis are

$$\begin{aligned} \mathbf{W}_{\mathbf{e}_1} &= \mathbf{e}_3 \otimes \mathbf{e}_2 - \mathbf{e}_2 \otimes \mathbf{e}_3, \\ \mathbf{W}_{\mathbf{e}_2} &= \mathbf{e}_1 \otimes \mathbf{e}_3 - \mathbf{e}_3 \otimes \mathbf{e}_1, \\ \mathbf{W}_{\mathbf{e}_3} &= \mathbf{e}_2 \otimes \mathbf{e}_1 - \mathbf{e}_1 \otimes \mathbf{e}_2. \end{aligned}$$

⁶It is evident that this is true also for one- and two-dimensional vector spaces.

2.11 Rotations

In the previous Chapter we have seen that the elements of \mathcal{V} represent translations over \mathcal{E} . A *rotation*, i.e. a rigid rotation of the space, is an operation that transforms any two vectors \mathbf{u} and \mathbf{v} into two other vectors \mathbf{u}' and \mathbf{v}' in such a way that

$$u = u', \quad v = v', \quad \mathbf{u} \cdot \mathbf{v} = \mathbf{u}' \cdot \mathbf{v}', \quad (2.31)$$

i.e. it preserves norms and angles. Because a rotation is a transformation from \mathcal{V} to \mathcal{V} , rotations are tensors, i.e. we can write

$$\mathbf{v}' = \mathbf{R}\mathbf{v},$$

with \mathbf{R} the *rotation tensor* or simply the *rotation*.

Conditions (2.31) impose some restrictions on \mathbf{R} :

$$\mathbf{u}' \cdot \mathbf{v}' = \mathbf{R}\mathbf{u} \cdot \mathbf{R}\mathbf{v} = \mathbf{u} \cdot \mathbf{R}^\top \mathbf{R}\mathbf{v} = \mathbf{u} \cdot \mathbf{v} \iff \mathbf{R}^\top \mathbf{R} = \mathbf{I} = \mathbf{R}\mathbf{R}^\top.$$

A tensor that preserves angles belongs to $Orth(\mathcal{V})$, the subspace of *orthogonal tensors* (we leave to the reader the proof that actually $Orth(\mathcal{V})$ is a subspace of $Lin(\mathcal{V})$). Replacing in the above equation \mathbf{v} with \mathbf{u} shows immediately that an orthogonal tensor preserves also the norms. By the uniqueness of the inverse, we see that

$$\mathbf{R} \in Orth(\mathcal{V}) \iff \mathbf{R}^{-1} = \mathbf{R}^\top.$$

The above condition is not sufficient to characterize a rotation; in fact, a rotation must transform a right-handed basis into another right-handed basis, i.e. it must *preserve the orientation of the space*. This means that it must be

$$\mathbf{e}'_1 \times \mathbf{e}'_2 \cdot \mathbf{e}'_3 = \mathbf{R}\mathbf{e}_1 \times \mathbf{R}\mathbf{e}_2 \cdot \mathbf{R}\mathbf{e}_3 = \mathbf{e}_1 \times \mathbf{e}_2 \cdot \mathbf{e}_3.$$

By eq. (2.30) we get hence the condition⁷

$$\det \mathbf{R}(\mathbf{e}_1 \times \mathbf{e}_2 \cdot \mathbf{e}_3) = \mathbf{e}_1 \times \mathbf{e}_2 \cdot \mathbf{e}_3 \iff \det \mathbf{R} = 1.$$

The tensors of $Orth(\mathcal{V})$ that have a determinant equal to 1 form the subspace of *proper rotations* or simply *rotations*, indicated by $Orth(\mathcal{V})^+$ or also by $SO(3)$. Only tensors of $Orth(\mathcal{V})^+$ represent rigid rotations of \mathcal{E} ⁸.

Theorem 12. : *each tensor $\mathbf{R} \in Orth(\mathcal{V})$ has the eigenvalue ± 1 , with $+1$ for rotations.*

Proof. Be \mathbf{u} an eigenvector of $\mathbf{R} \in Orth(\mathcal{V})$ corresponding to the eigenvalue λ . Because \mathbf{R} preserves the norm, it is

$$\mathbf{R}\mathbf{u} \cdot \mathbf{R}\mathbf{u} = \lambda^2 \mathbf{u}^2 = \mathbf{u}^2 \rightarrow \lambda^2 = 1.$$

⁷From the condition $\mathbf{R}^\top \mathbf{R} = \mathbf{I}$ and through eq.(2.13) and the Theorem of Binet, we recognize immediately that $\det \mathbf{R} = \pm 1 \quad \forall \mathbf{R} \in Orth(\mathcal{V})$.

⁸A tensor $\mathbf{S} \in Orth(\mathcal{V})$ such that $\det \mathbf{S} = -1$ represents a transformation that changes the orientation of the space, like mirror symmetries do, see Sect. 2.12.

We now must prove that it exists at least one real eigenvector λ . To this end, we consider the characteristic equation

$$f(\lambda) = \lambda^3 + k_1\lambda^2 + k_2\lambda + k_3 = 0,$$

whose coefficients k_i are real-valued, because \mathbf{R} has real-valued components. It is immediate to recognize that

$$\lim_{\lambda \rightarrow \pm\infty} f(\lambda) = \pm\infty.$$

So, because $f(\lambda)$ is a real-valued continuous function, actually a polynomial of λ , it exists at least one $\lambda_1 \in \mathbb{R}$ such that

$$f(\lambda_1) = 0.$$

In addition, we already know that $\forall \mathbf{R} \in Orth(\mathcal{V})$, $\det \mathbf{R} = \pm 1$ and that, if $\lambda_i, i = 1, 2, 3$ are the eigenvalues of \mathbf{R} , then $\det \mathbf{R} = \lambda_1\lambda_2\lambda_3$. Hence, two are the possible cases:

- i. $\lambda_1 \in \mathbb{R}$ and $\lambda_2, \lambda_3 \in \mathbb{C}$, with $\lambda_3 = \bar{\lambda}_2$, the complex conjugate of λ_2 ;
- ii. $\lambda_i \in \mathbb{R} \forall i = 1, 2, 3$.

Let us consider the case of $\mathbf{R} \in Orth(\mathcal{V})^+$, i.e. a (proper) rotation $\rightarrow \det \mathbf{R} = 1$. Then, in the first case above,

$$\det \mathbf{R} = \lambda_1\lambda_2\bar{\lambda}_2 = \lambda_1[\Re^2(\lambda_2) + \Im^2(\lambda_2)].$$

But

$$\Re^2(\lambda_2) + \Im^2(\lambda_2) = 1$$

because it is the square of the modulus of the complex eigenvalue λ_2 . So in this case

$$\det \mathbf{R} = 1 \iff \lambda_1 = 1.$$

In the second case, $\lambda_i \in \mathbb{R} \forall i = 1, 2, 3$, either $\lambda_1 > 0, \lambda_2, \lambda_3 < 0$, or all of them are positive. Because the modulus of each eigenvalue must be equal to 1, either $\lambda_1 = 1$ or $\lambda_i = 1 \forall i = 1, 2, 3$ (in this case $\mathbf{R} = \mathbf{I}$).

Following the same steps, one arrives easily to show that $\forall \mathbf{S} \in Orth(\mathcal{V})$ with $\det \mathbf{S} = -1$, it exists at least one real eigenvalue $\lambda_1 = -1$. \square

Generally speaking, a rotation tensor rotates the basis $\mathcal{B} = \{\mathbf{e}_1, \mathbf{e}_2, \mathbf{e}_3\}$ into the basis $\mathcal{B}' = \{\mathbf{e}'_1, \mathbf{e}'_2, \mathbf{e}'_3\}$:

$$\mathbf{R}\mathbf{e}_i = \mathbf{e}'_i \quad \forall i = 1, 2, 3 \Rightarrow R_{ij} = \mathbf{e}_i \cdot \mathbf{R}\mathbf{e}_j = \mathbf{e}_i \cdot \mathbf{e}'_j. \quad (2.32)$$

This result actually means that the j -th column of \mathbf{R} is composed by the components in the basis \mathcal{B} of the vector \mathbf{e}'_j of \mathcal{B}' . Because the two bases are orthonormal, such components are the director cosines of the axes of \mathcal{B}' with respect to \mathcal{B} .

Geometrically speaking, any rotation is characterized by an *axis of rotation* \mathbf{w} , $|\mathbf{w}| = 1$ and by an *amplitude* φ , i.e. the angle through which the space is rotated about \mathbf{w} . By definition, \mathbf{w} is the (only) vector that is left unchanged by \mathbf{R} , i.e.

$$\mathbf{R}\mathbf{w} = \mathbf{w},$$

or, in other words, it is the eigenvector corresponding to the eigenvalue $+1$.

The question is then: how a rotation tensor \mathbf{R} can be expressed by means of its geometrical parameters, \mathbf{w} and φ ? To this end we have a fundamental theorem:

Theorem 13. (*Euler's rotation representation theorem*): $\forall \mathbf{R} \in \text{Orth}(\mathcal{V})^+$,

$$\mathbf{R} = \mathbf{I} + \sin \varphi \mathbf{W} + (1 - \cos \varphi) \mathbf{W}^2 \quad (2.33)$$

with φ the rotation's amplitude and \mathbf{W} the axial tensor of the rotation axis \mathbf{w} .

Proof. We observe preliminarily that

$$\mathbf{R}\mathbf{w} = \mathbf{I}\mathbf{w} + \sin \varphi \mathbf{W}\mathbf{w} + (1 - \cos \varphi) \mathbf{W}\mathbf{W}\mathbf{w} = \mathbf{I}\mathbf{w} = \mathbf{w} \quad (2.34)$$

i.e. that eq. (2.33) actually defines a transformation that leaves unchanged the axis \mathbf{w} , like a rotation about \mathbf{w} must do, and that $+1$ is an eigenvalue of \mathbf{R} .

We need now to prove that eq. (2.33) actually represents a rotation tensor, i.e. we must prove that

$$\mathbf{R}\mathbf{R}^\top = \mathbf{I}, \quad \det \mathbf{R} = 1.$$

Through eq. (2.25) we get

$$\begin{aligned} \mathbf{R}\mathbf{R}^\top &= (\mathbf{I} + \sin \varphi \mathbf{W} + (1 - \cos \varphi) \mathbf{W}^2)(\mathbf{I} + \sin \varphi \mathbf{W} + (1 - \cos \varphi) \mathbf{W}^2)^\top \\ &= (\mathbf{I} + \sin \varphi \mathbf{W} + (1 - \cos \varphi) \mathbf{W}^2)(\mathbf{I} - \sin \varphi \mathbf{W} + (1 - \cos \varphi) \mathbf{W}^2) \\ &= \mathbf{I} + 2(1 - \cos \varphi) \mathbf{W}^2 - \sin^2 \varphi \mathbf{W}^2 + (1 - \cos \varphi)^2 \mathbf{W}^4 \\ &= \mathbf{I} + 2(1 - \cos \varphi) \mathbf{W}^2 - \sin^2 \varphi \mathbf{W}^2 - (1 - \cos \varphi)^2 \mathbf{W}^2 = \mathbf{I}. \end{aligned}$$

Then, through eq. (2.24) we obtain

$$\begin{aligned} \mathbf{R} &= \mathbf{I} + \sin \varphi \mathbf{W} + (1 - \cos \varphi) \mathbf{W}^2 \\ &= \mathbf{I} + \sin \varphi \mathbf{W} - (1 - \cos \varphi)(\mathbf{I} - \mathbf{w} \otimes \mathbf{w}) \\ &= \cos \varphi \mathbf{I} + \sin \varphi \mathbf{W} + (1 - \cos \varphi) \mathbf{w} \otimes \mathbf{w}. \end{aligned} \quad (2.35)$$

To go on, we need to express \mathbf{W} and $\mathbf{w} \otimes \mathbf{w}$; if $\mathbf{w} = (w_1, w_2, w_3)$, then by eq. (2.20) we have

$$\mathbf{W} = \begin{bmatrix} 0 & -w_3 & w_2 \\ w_3 & 0 & -w_1 \\ -w_2 & w_1 & 0 \end{bmatrix}$$

and by eq. (2.2)

$$\mathbf{w} \otimes \mathbf{w} = \begin{bmatrix} w_1^2 & w_1 w_2 & w_1 w_3 \\ w_1 w_2 & w_2^2 & w_2 w_3 \\ w_1 w_3 & w_2 w_3 & w_3^2 \end{bmatrix},$$

that injected into eq. (2.35) gives

$$\mathbf{R} = \begin{bmatrix} \cos \varphi + (1 - \cos \varphi) w_1^2 & -w_3 \sin \varphi + w_1 w_2 (1 - \cos \varphi) & w_2 \sin \varphi + w_1 w_3 (1 - \cos \varphi) \\ w_3 \sin \varphi + w_1 w_2 (1 - \cos \varphi) & \cos \varphi + (1 - \cos \varphi) w_2^2 & -w_1 \sin \varphi + w_2 w_3 (1 - \cos \varphi) \\ -w_2 \sin \varphi + w_1 w_3 (1 - \cos \varphi) & w_1 \sin \varphi + w_2 w_3 (1 - \cos \varphi) & \cos \varphi + (1 - \cos \varphi) w_3^2 \end{bmatrix}. \quad (2.36)$$

This formula gives \mathbf{R} as function exclusively of \mathbf{w} and φ , the geometrical elements of the rotation. Then

$$\det \mathbf{R} = (w^2 + (1 - w^2) \cos \varphi)(\cos^2 \varphi + w^2 \sin^2 \varphi)$$

and because $w = 1$, $\det \mathbf{R} = 1$, which proves that eq. (2.33) actually represents a rotation.

We eventually need to prove that eq. (2.33) represents the rotation about \mathbf{w} of amplitude φ . To this end, we choose an orthonormal basis $\mathcal{B} = \{\mathbf{e}_1, \mathbf{e}_2, \mathbf{e}_3\}$ of \mathcal{V} such that $\mathbf{w} = \mathbf{e}_3$, i.e. we analyze the particular case of a rotation of amplitude φ about \mathbf{e}_3 . This is always possible, thanks to the arbitrariness of the basis of \mathcal{V} . In such a case, eq. (2.32) gives

$$\mathbf{R} = \begin{bmatrix} \cos \varphi & -\sin \varphi & 0 \\ \sin \varphi & \cos \varphi & 0 \\ 0 & 0 & 1 \end{bmatrix}. \quad (2.37)$$

Moreover,

$$\mathbf{W} = \begin{bmatrix} 0 & -1 & 0 \\ 1 & 0 & 0 \\ 0 & 0 & 0 \end{bmatrix}, \quad \mathbf{w} \otimes \mathbf{w} = \begin{bmatrix} 0 & 0 & 0 \\ 0 & 0 & 0 \\ 0 & 0 & 1 \end{bmatrix},$$

$$\mathbf{W}^2 = -(\mathbf{I} - \mathbf{w} \otimes \mathbf{w}) = \begin{bmatrix} -1 & 0 & 0 \\ 0 & -1 & 0 \\ 0 & 0 & 0 \end{bmatrix}.$$

Hence

$$\begin{aligned} \mathbf{I} + \sin \varphi \mathbf{W} + (1 - \cos \varphi) \mathbf{W}^2 &= \begin{bmatrix} 1 & 0 & 0 \\ 0 & 1 & 0 \\ 0 & 0 & 1 \end{bmatrix} + \sin \varphi \begin{bmatrix} 0 & -1 & 0 \\ 1 & 0 & 0 \\ 0 & 0 & 0 \end{bmatrix} + \\ &+ (1 - \cos \varphi) \begin{bmatrix} -1 & 0 & 0 \\ 0 & -1 & 0 \\ 0 & 0 & 0 \end{bmatrix} = \begin{bmatrix} \cos \varphi & -\sin \varphi & 0 \\ \sin \varphi & \cos \varphi & 0 \\ 0 & 0 & 1 \end{bmatrix} = \mathbf{R}. \end{aligned} \quad (2.38)$$

□

Equation (2.33) gives another result: to obtain the inverse of \mathbf{R} it is sufficient to change the sign of φ . In fact, because $\mathbf{W} \in Skw(\mathcal{V})$ and through eq. (2.23)

$$\begin{aligned} \mathbf{R}^{-1} &= \mathbf{R}^\top = (\mathbf{I} + \sin \varphi \mathbf{W} + (1 - \cos \varphi) \mathbf{W}^2)^\top = \mathbf{I} + \sin \varphi \mathbf{W}^\top + (1 - \cos \varphi) (\mathbf{W}^2)^\top \\ &= \mathbf{I} - \sin \varphi \mathbf{W} + (1 - \cos \varphi) \mathbf{W}^2 = \mathbf{I} + \sin(-\varphi) \mathbf{W} + (1 - \cos(-\varphi)) \mathbf{W}^2. \end{aligned}$$

The knowledge of the inverse of a rotation allows also to perform the operation of *change of basis*, i.e. to determine the components of a vector or of a tensor in a basis $\mathcal{B}' = \{\mathbf{e}'_1, \mathbf{e}'_2, \mathbf{e}'_3\}$ rotated with respect to an original basis $\mathcal{B} = \{\mathbf{e}_1, \mathbf{e}_2, \mathbf{e}_3\}$ by a rotation \mathbf{R} (in the following equation, a prime indicates a quantity specified in the basis \mathcal{B}'). Considering that

$$\mathbf{e}_i = \mathbf{R}^{-1} \mathbf{e}'_i = \mathbf{R}^\top \mathbf{e}'_i = R_{hk}^\top (\mathbf{e}'_h \otimes \mathbf{e}'_k) \mathbf{e}_i = R_{hk}^\top \delta_{ki} \mathbf{e}'_h$$

we get, for a vector \mathbf{u} ,

$$\mathbf{u} = u_i \mathbf{e}_i = u_i R_{ki}^\top \mathbf{e}'_k$$

i.e.

$$u'_k = R_{ki}^\top u_i \rightarrow \mathbf{u}' = \mathbf{R}^\top \mathbf{u}.$$

We remark that, because $\mathbf{R}^\top = \mathbf{R}^{-1}$, the operation of change of basis is just the opposite one of the rotation of the space (and actually, we have seen that it is sufficient to take the opposite of φ in eq. (2.33) to get \mathbf{R}^{-1}).

For a second-rank tensor \mathbf{L} we get

$$\mathbf{L} = L_{ij} \mathbf{e}_i \otimes \mathbf{e}_j = L_{ij} R_{mi}^\top \mathbf{e}'_m \otimes R_{nj}^\top \mathbf{e}'_n = R_{mi}^\top R_{nj}^\top L_{ij} \mathbf{e}'_m \otimes \mathbf{e}'_n,$$

i.e.

$$L'_{mn} = R_{mi}^\top R_{nj}^\top L_{ij} \rightarrow \mathbf{L}' = \mathbf{R}^\top \mathbf{L} \mathbf{R}.$$

We remark something that is typical of tensors: the components of a r -rank tensor in a rotated basis \mathcal{B}' depend upon the r -th powers of the directors cosines of the axes of \mathcal{B}' , i.e. on the r -th powers of the components R_{ij} of \mathbf{R} .

If a rotation tensor is known through its Cartesian components in a given basis \mathcal{B} , it is easy to calculate its geometrical elements: the rotation axis \mathbf{w} is the eigenvector of \mathbf{R} corresponding to the eigenvalue 1, so it is found solving the equation

$$\mathbf{R} \mathbf{w} = \mathbf{w}$$

and then normalizing it, while the rotation amplitude φ can be found still using (2.33): because the trace of a tensor is an invariant, we get

$$\text{tr} \mathbf{R} = 3 + (1 - \cos \varphi) \text{tr}(-\mathbf{I} + \mathbf{w} \cdot \mathbf{w}) = 1 + 2 \cos \varphi \rightarrow \varphi = \arccos \frac{\text{tr} \mathbf{R} - 1}{2}.$$

It is interesting to consider the geometrical meaning of eq. (2.33). To this purpose we apply eq. (2.33) to a vector \mathbf{u} , see Fig. 2.2

$$\begin{aligned} \mathbf{R} \mathbf{u} &= (\mathbf{I} + \sin \varphi \mathbf{W} + (1 - \cos \varphi) \mathbf{W}^2) \mathbf{u} \\ &= \mathbf{u} + \sin \varphi \mathbf{w} \times \mathbf{u} + (1 - \cos \varphi) \mathbf{w} \times (\mathbf{w} \times \mathbf{u}) \end{aligned}$$

The rotated vector $\mathbf{R} \mathbf{u}$ is the sum of three vectors; in particular, $\sin \varphi \mathbf{W} \mathbf{u}$ is always orthogonal to \mathbf{u} , \mathbf{w} and $(1 - \cos \varphi) \mathbf{W}^2 \mathbf{u}$. If $\mathbf{u} \cdot \mathbf{w} = 0$, see the sketch on the right in Fig. 2.2, then $(1 - \cos \varphi) \mathbf{W}^2 \mathbf{u}$ is also parallel to \mathbf{u} .

Let us consider now a composition of rotations. In particular, let us imagine that a vector \mathbf{u} is rotated first by \mathbf{R}_1 , around \mathbf{w}_1 through φ_1 , then by \mathbf{R}_2 , around \mathbf{w}_2 through φ_2 . So, first the vector \mathbf{u} becomes the vector

$$\mathbf{u}_1 = \mathbf{R}_1 \mathbf{u}.$$

Then, the vector \mathbf{u}_1 is rotated about \mathbf{w}_2 through φ_2 to become

$$\mathbf{u}_{12} = \mathbf{R}_2 \mathbf{u}_1 = \mathbf{R}_2 \mathbf{R}_1 \mathbf{u}.$$

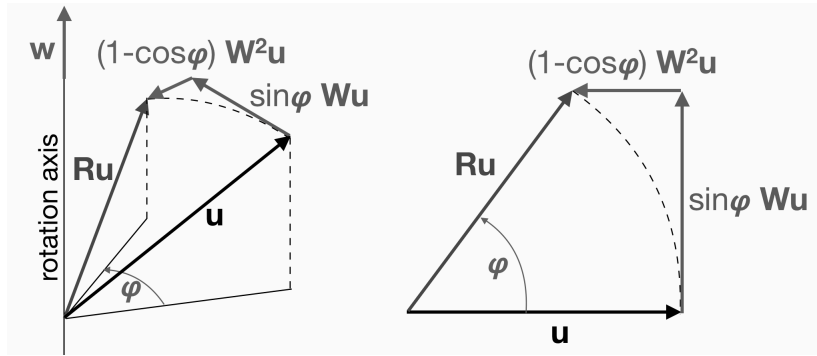

Figure 2.2: Rotation of a vector.

Let us now suppose to change the order of the rotations: \mathbf{R}_2 first and then \mathbf{R}_1 . The final result will be the vector

$$\mathbf{u}_{21} = \mathbf{R}_1 \mathbf{R}_2 \mathbf{u}. \quad (2.39)$$

Because the tensor product is not symmetric (i.e., it has not the commutativity property), generally speaking⁹

$$\mathbf{u}_{12} \neq \mathbf{u}_{21}.$$

In other words, the order of the rotations matters: changing the order of the rotations leads to a different final result. An example is shown in Fig. 2.3.

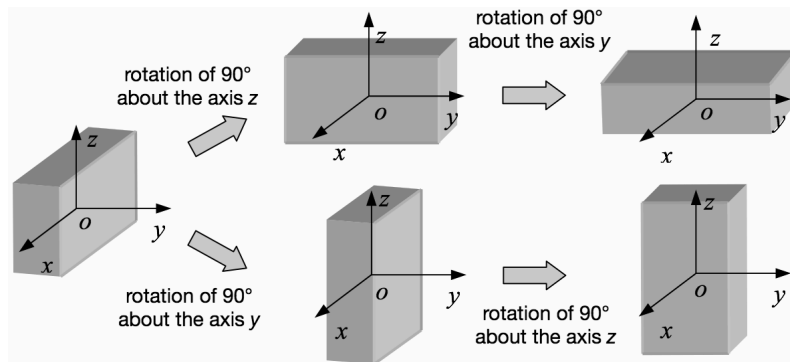

Figure 2.3: Non-commutativity of the rotations.

This is a fundamental difference between rotations and displacements, that commute, see Fig. 1.2, because the composition of displacements is ruled by the sum of vectors:

$$\mathbf{w} = \mathbf{u} + \mathbf{v} = \mathbf{v} + \mathbf{u} \quad (2.40)$$

This difference, which is a major point in physics, comes from the difference of the operators: vectors for the displacements, tensors for the rotations.

⁹We have seen, Theorem 7, that two tensors commute \iff they are coaxial, i.e. if they have the same eigenvectors. Because the rotation axis is always a real eigenvector of a rotation tensor, if two tensors operate a rotation about different axes they are not coaxial. Hence, the rotation tensors about different axes never commute.

Any rotation can be specified by the knowledge of three parameters. This can be easily seen from eq. (2.33): the parameters are the three components of \mathbf{w} , that are not independent because

$$w = |\mathbf{w}| = \sqrt{w_1^2 + w_2^2 + w_3^2} = 1$$

and by the amplitude angle φ . The choice of the parameters by which to express a rotation is not unique. Besides the use of the Cartesian components of \mathbf{w} and φ , other choices are possible, let us see three of them:

- i. *physical angles*: the rotation axis \mathbf{w} is given through its spherical coordinates ψ , the *longitude*, $0 \leq \psi < 2\pi$, and θ , the *colatitude*, $0 \leq \theta \leq \pi$, see Fig. 2.4, the third parameter being the *rotation amplitude* φ . Then

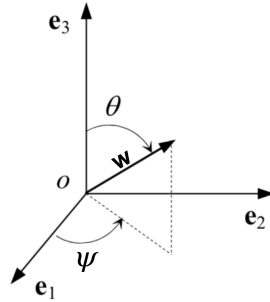

Figure 2.4: Physical angles.

$$\mathbf{w} = (\sin \theta \cos \psi, \sin \theta \sin \psi, \cos \theta) \rightarrow \theta = \arccos w_3, \quad \psi = \arctan \frac{w_2}{w_1},$$

and, eq. (2.36),

$$\mathbf{R} = \begin{bmatrix} c\psi^2 s\theta^2 + c\varphi(c\theta^2 + s\psi^2 s\theta^2) & s\psi c\psi s\theta^2(1 - c\varphi) - c\theta s\varphi & c\psi s\theta c\theta(1 - c\varphi) + s\psi s\theta s\varphi \\ s\psi c\psi s\theta^2(1 - c\varphi) + c\theta s\varphi & s\psi^2 s\theta^2 + c\varphi(c\theta^2 + c\psi^2 s\theta^2) & s\psi s\theta c\theta(1 - c\varphi) - c\psi s\theta s\varphi \\ c\psi s\theta c\theta(1 - c\varphi) - s\psi s\theta s\varphi & s\psi s\theta c\theta(1 - c\varphi) + c\psi s\theta s\varphi & c\theta^2 + c\varphi(c\psi^2 s\theta^2 + s\psi^2 s\theta^2) \end{bmatrix},$$

where $c\psi = \cos \psi$, $s\psi = \sin \psi$, $c\theta = \cos \theta$, $s\theta = \sin \theta$, $c\varphi = \cos \varphi$, $s\varphi = \sin \varphi$. We remark that all the components of \mathbf{R} so expressed depend upon the first powers of the circular functions of φ . Hence, for what said above, with this representation of the rotations, the components of a rotated r -rank tensor depend upon the r -th power of the circular functions of φ , i.e. of the physical rotation, but not on ψ nor on θ .

- ii. *Euler's angles*: in this case the three parameters are the amplitude of three particular rotations into which the rotation is decomposed. Such parameters are the angles ψ , the *precession*, θ , the *nutation*, and φ , the *proper rotation*, see Fig. 2.5 These three rotations are represented in Fig. 2.6. The first one, of amplitude ψ , is made about z to carry the axis x onto the *knots line* x_N , the line perpendicular to both the axes z and z' , and y onto \bar{y} ; by eq. (2.32), in the frame $\{x, y, z\}$ it is

$$\mathbf{R}_\psi = \begin{bmatrix} \cos \psi & -\sin \psi & 0 \\ \sin \psi & \cos \psi & 0 \\ 0 & 0 & 1 \end{bmatrix}.$$

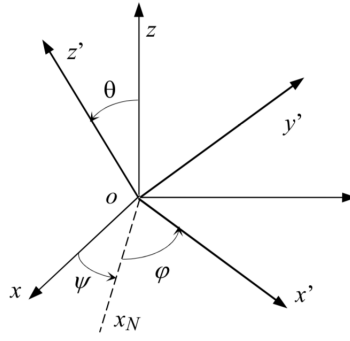

Figure 2.5: Euler's angles.

The second one, of amplitude θ , is made about x_N to carry z onto z' ; in the frame $\{x_N, \bar{y}, z\}$ it is

$$\mathbf{R}_\theta = \begin{bmatrix} 1 & 0 & 0 \\ 0 & \cos \theta & -\sin \theta \\ 0 & \sin \theta & \cos \theta \end{bmatrix},$$

while in the frame $\{x, y, z\}$

$$\mathbf{R}_\theta^o = (\mathbf{R}_\psi^{-1})^\top \mathbf{R}_\theta \mathbf{R}_\psi^{-1} = \mathbf{R}_\psi \mathbf{R}_\theta \mathbf{R}_\psi^\top.$$

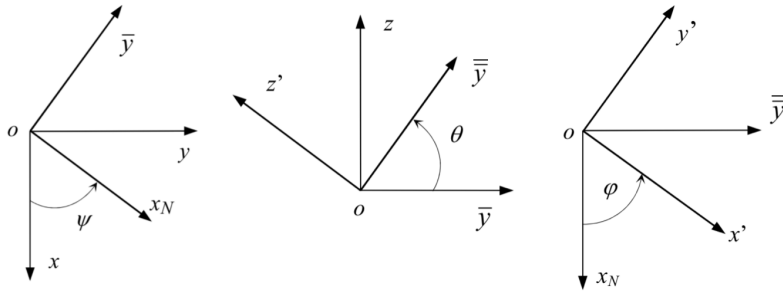

Figure 2.6: Euler's rotations, as seen from the respective axes of rotation.

The last rotation, of amplitude φ , is made about z' to carry x_N onto x' and \bar{y} onto y' ; in the frame $\{x_N, \bar{y}, z'\}$ it is

$$\mathbf{R}_\varphi = \begin{bmatrix} \cos \varphi & -\sin \varphi & 0 \\ \sin \varphi & \cos \varphi & 0 \\ 0 & 0 & 1 \end{bmatrix},$$

while in $\{x, y, z\}$

$$\mathbf{R}_\varphi^o = (\mathbf{R}_\psi^{-1})^\top (\mathbf{R}_\theta^{-1})^\top \mathbf{R}_\varphi \mathbf{R}_\theta^{-1} \mathbf{R}_\psi^{-1} = \mathbf{R}_\psi \mathbf{R}_\theta \mathbf{R}_\varphi \mathbf{R}_\theta^\top \mathbf{R}_\psi^\top.$$

Any vector \mathbf{u} is transformed, by the global rotation, into the vector

$$\mathbf{u}' = \mathbf{R}\mathbf{u}.$$

But we can write also

$$\mathbf{u}' = \mathbf{R}_\varphi^o \bar{\bar{\mathbf{u}}},$$

where $\bar{\bar{\mathbf{u}}}$ is the vector transformed by rotation \mathbf{R}_θ^o ,

$$\bar{\bar{\mathbf{u}}} = \mathbf{R}_\theta^o \bar{\mathbf{u}},$$

and $\bar{\mathbf{u}}$ is the vector transformed by rotation \mathbf{R}_ψ ,

$$\bar{\mathbf{u}} = \mathbf{R}_\psi \mathbf{u}.$$

Finally,

$$\mathbf{u}' = \mathbf{R}\mathbf{u} = \mathbf{R}_\varphi^o \mathbf{R}_\theta^o \mathbf{R}_\psi \mathbf{u} \rightarrow \mathbf{R} = \mathbf{R}_\varphi^o \mathbf{R}_\theta^o \mathbf{R}_\psi,$$

i.e. the global rotation tensor is obtained composing, in the opposite order of execution of the rotations, the three tensors all expressed in the original basis. However,

$$\mathbf{R} = \mathbf{R}_\varphi^o \mathbf{R}_\theta^o \mathbf{R}_\psi = \mathbf{R}_\psi \mathbf{R}_\theta \mathbf{R}_\varphi \mathbf{R}_\theta^\top \mathbf{R}_\psi^\top \mathbf{R}_\varphi^\top \mathbf{R}_\psi \mathbf{R}_\theta \mathbf{R}_\psi^\top \mathbf{R}_\varphi = \mathbf{R}_\psi \mathbf{R}_\theta \mathbf{R}_\varphi,$$

i.e., the global rotation tensor is also equal to the composition of the three rotations, in the order of execution, if the three rotations are expressed in their own particular bases. This result is general, not bounded to the Euler's rotations nor to three rotations.

Performing the tensor multiplications we get

$$\mathbf{R} = \begin{bmatrix} \cos \psi \cos \varphi - \sin \psi \sin \varphi \cos \theta & -\cos \psi \sin \varphi - \sin \psi \cos \varphi \cos \theta & \sin \psi \sin \theta \\ \sin \psi \cos \varphi + \cos \psi \sin \varphi \cos \theta & -\sin \psi \sin \varphi + \cos \psi \cos \varphi \cos \theta & -\cos \psi \sin \theta \\ \sin \varphi \sin \theta & \cos \varphi \sin \theta & \cos \theta \end{bmatrix}.$$

The components of a vector \mathbf{u} in the basis \mathcal{B}' are then given by

$$\mathbf{u}' = \mathbf{R}^\top \mathbf{u} = \mathbf{R}_\varphi^\top \mathbf{R}_\theta^\top \mathbf{R}_\psi^\top \mathbf{u},$$

and those of a second-rank tensor

$$\mathbf{L}' = \mathbf{R}^\top \mathbf{L} \mathbf{R} = \mathbf{R}_\varphi^\top \mathbf{R}_\theta^\top \mathbf{R}_\psi^\top \mathbf{L} \mathbf{R}_\psi \mathbf{R}_\theta \mathbf{R}_\varphi.$$

- iii. *coordinate angles*: in this case, the rotation \mathbf{R} is decomposed into three successive rotations α, β, γ , respectively about the axes x, y and z of each rotation, i.e.

$$\mathbf{R} = \mathbf{R}_\alpha \mathbf{R}_\beta \mathbf{R}_\gamma$$

with

$$\mathbf{R}_\alpha = \begin{bmatrix} 1 & 0 & 0 \\ 0 & \cos \alpha & -\sin \alpha \\ 0 & \sin \alpha & \cos \alpha \end{bmatrix}, \mathbf{R}_\beta = \begin{bmatrix} \cos \beta & 0 & -\sin \beta \\ 0 & 1 & 0 \\ \sin \beta & 0 & \cos \beta \end{bmatrix}, \mathbf{R}_\gamma = \begin{bmatrix} \cos \gamma & -\sin \gamma & 0 \\ \sin \gamma & \cos \gamma & 0 \\ 0 & 0 & 1 \end{bmatrix},$$

so finally

$$\mathbf{R} = \begin{bmatrix} \cos \beta \cos \gamma & -\cos \beta \sin \gamma & -\sin \beta \\ \cos \alpha \sin \gamma - \sin \alpha \sin \beta \cos \gamma & \cos \alpha \cos \gamma + \sin \alpha \sin \beta \sin \gamma & -\sin \alpha \cos \beta \\ \sin \alpha \sin \gamma + \cos \alpha \sin \beta \cos \gamma & \sin \alpha \cos \gamma - \cos \alpha \sin \beta \sin \gamma & \cos \alpha \cos \beta \end{bmatrix}.$$

Let us now consider the case of *small rotations*, i.e. $|\varphi| \rightarrow 0$. In such a case,

$$\sin \varphi \simeq \varphi, \quad 1 - \cos \varphi \simeq 0$$

and

$$\mathbf{R} \simeq \mathbf{I} + \varphi \mathbf{W},$$

i.e. in the small rotations approximation, any vector \mathbf{u} is transformed as

$$\mathbf{R}\mathbf{u} \simeq (\mathbf{I} + \varphi \mathbf{W})\mathbf{u} = \mathbf{u} + \varphi \mathbf{w} \times \mathbf{u}, \quad (2.41)$$

i.e. by a skew tensor, not by a rotation tensor. The term $(1 - \cos \varphi) \mathbf{W}^2 \mathbf{u}$ has disappeared (i.e., it is a higher order infinitesimal quantity) and the term $\varphi \mathbf{w} \times \mathbf{u}$ is orthogonal to \mathbf{u} . Because $\varphi \rightarrow 0$, the arc is approximated by its tangent, the vector $\varphi \mathbf{w} \times \mathbf{u}$, see Fig. 2.7. Applying to eq. (2.41) the procedure already seen for the composition of finite amplitude

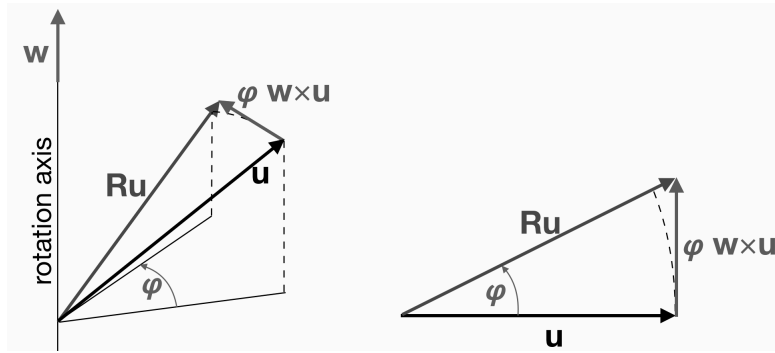

Figure 2.7: Small rotations.

rotations, we get

$$\begin{aligned} \mathbf{u}_1 &= \mathbf{R}_1 \mathbf{u} = (\mathbf{I} + \varphi_1 \mathbf{W}_1) \mathbf{u} = \mathbf{u} + \varphi_1 \mathbf{w}_1 \times \mathbf{u}, \\ \mathbf{u}_{21} &= \mathbf{R}_2 \mathbf{u}_1 = (\mathbf{I} + \varphi_2 \mathbf{W}_2) \mathbf{u}_1 = \mathbf{u}_1 + \varphi_2 \mathbf{w}_2 \times \mathbf{u}_1 \\ &= \mathbf{u} + \varphi_1 \mathbf{w}_1 \times \mathbf{u} + \varphi_2 \mathbf{w}_2 \times \mathbf{u} \\ &\quad + \varphi_1 \varphi_2 \mathbf{w}_2 \times (\mathbf{w}_1 \times \mathbf{u}). \end{aligned}$$

If the order of the rotations is changed, the last term becomes $\varphi_1 \varphi_2 \mathbf{w}_1 \times (\mathbf{w}_2 \times \mathbf{u})$, which is, in general, different from $\varphi_1 \varphi_2 \mathbf{w}_2 \times (\mathbf{w}_1 \times \mathbf{u})$: strictly speaking, also small rotations do not commute¹⁰. However, for small rotations, $\varphi_1 \varphi_2$ is negligible with respect to φ_1 and φ_2 : in this approximation, small rotations commute. To remark that the approximation (2.41) gives, for the displacements, a law which is quite similar to that of the velocities of the points of a rigid body:

$$\mathbf{v} = \mathbf{v}_0 + \boldsymbol{\omega} \times (\mathbf{p} - \mathbf{o})$$

This is quite natural, because

$$\boldsymbol{\omega} = \frac{d\varphi}{dt},$$

i.e. a small amplitude rotation can be seen as the rotation made with finite angular velocity $\boldsymbol{\omega}$ in a small time interval dt .

¹⁰This can happen for some vectors, all the times that $\mathbf{w}_1 \cdot \mathbf{u} = \mathbf{w}_2 \cdot \mathbf{u}$, like for the case of a vector \mathbf{u} orthogonal to both \mathbf{w}_1 and \mathbf{w}_2 ; however, this is no more than a curiosity, it has no importance in practice.

2.12 Reflexions

Let us consider now tensors $\mathbf{S} \in Orth(\mathcal{V})$ that are not a rotation, i.e. such that $\det \mathbf{S} = -1$. Let us call \mathbf{S} an *improper rotation*. A particular improper rotation, whose all eigenvalues are equal to -1, is the *inversion* or *reflexion tensor*

$$\mathbf{S}_I = -\mathbf{I}.$$

The effect of \mathbf{S}_I is to transform any basis \mathcal{B} into the basis $-\mathcal{B}$, i.e. with all the basis vectors changed of orientation (or, which is the same, to change the sign of all the components of a vector). In other words, \mathbf{S}_I changes the orientation of the space. This is also the effect of any other improper rotation \mathbf{S} , that can be decomposed into a proper rotation \mathbf{R} followed by the reflexion \mathbf{S}_I ¹¹:

$$\mathbf{S} = \mathbf{S}_I \mathbf{R}. \quad (2.42)$$

Be $\mathbf{n} \in \mathcal{S}$, then

$$\mathbf{S}_R = \mathbf{I} - 2\mathbf{n} \otimes \mathbf{n} \quad (2.43)$$

is the tensor that operates the transformation of symmetry with respect to a plane orthogonal to \mathbf{n} . In fact

$$\mathbf{S}_R \mathbf{n} = -\mathbf{n}, \quad \mathbf{S}_R \mathbf{m} = \mathbf{m} \quad \forall \mathbf{m} \in \mathcal{V} : \mathbf{m} \cdot \mathbf{n} = 0.$$

\mathbf{S}_R is an improper rotation; in fact, eqs. (2.4), (2.14) and exercise 11,

$$\begin{aligned} (\mathbf{I} - 2\mathbf{n} \otimes \mathbf{n})(\mathbf{I} - 2\mathbf{n} \otimes \mathbf{n})^\top &= (\mathbf{I} - 2\mathbf{n} \otimes \mathbf{n})(\mathbf{I} - 2\mathbf{n} \otimes \mathbf{n}) \\ &= \mathbf{I} - 2\mathbf{n} \otimes \mathbf{n} - 2\mathbf{n} \otimes \mathbf{n} + 4(\mathbf{n} \otimes \mathbf{n})(\mathbf{n} \otimes \mathbf{n}) = \mathbf{I}, \end{aligned}$$

$$\det(\mathbf{I} - 2\mathbf{n} \otimes \mathbf{n}) = 1 - 2\text{tr}(\mathbf{n} \otimes \mathbf{n}) + 4 \frac{\text{tr}^2(\mathbf{n} \otimes \mathbf{n}) - \text{tr}(\mathbf{n} \otimes \mathbf{n})(\mathbf{n} \otimes \mathbf{n})}{2} - 8 \det(\mathbf{n} \otimes \mathbf{n}) = -1.$$

Be $\mathbf{S} = \mathbf{S}_I \mathbf{R}$ an improper rotation; then

$$\begin{aligned} (\mathbf{S}\mathbf{u}) \times (\mathbf{S}\mathbf{v}) &= (\mathbf{S}_I \mathbf{R}\mathbf{u}) \times (\mathbf{S}_I \mathbf{R}\mathbf{v}) = \det(\mathbf{S}_I \mathbf{R}) [(\mathbf{S}_I \mathbf{R})^{-1}]^\top (\mathbf{u} \times \mathbf{v}) \\ &= \det \mathbf{S}_I \det \mathbf{R} (\mathbf{R}^{-1} \mathbf{S}_I^{-1})^\top (\mathbf{u} \times \mathbf{v}) = -(-\mathbf{R}^{-1} \mathbf{I})^\top (\mathbf{u} \times \mathbf{v}) = \mathbf{R}(\mathbf{u} \times \mathbf{v}). \end{aligned}$$

The transformation by \mathbf{S} of any vector \mathbf{u} gives

$$\mathbf{S}\mathbf{u} = \mathbf{S}_I \mathbf{R}\mathbf{u} = -\mathbf{R}\mathbf{u},$$

i.e. it changes the orientation of the rotated vector; this is not the case when the same improper rotations transforms the vectors of a cross product: the rotated vector result of the cross product does not change of orientation, i.e. the cross product is insensitive to a reflexion. That is why, strictly speaking, the result of a cross product is not a vector, but a *pseudo-vector*: it behaves like vectors apart for the reflexions. For the same reason a scalar result of a mixed product (scalar plus cross product of three vectors) is called a *pseudo-scalar*, because in this case the scalar result of the mixed product changes of sign under a reflexion, as it is easy to be seen.

¹¹The application of the Binet's Theorem shows immediately that $\det \mathbf{S} = -1$, while $\mathbf{S}_I \mathbf{R} (\mathbf{S}_I \mathbf{R})^\top = \mathbf{S}_I \mathbf{R} \mathbf{R}^\top \mathbf{S}_I^\top = -\mathbf{I}(-\mathbf{I})^\top = \mathbf{I}$: the decomposition in eq. (2.42) actually gives an improper rotation.

2.13 Polar decomposition

Theorem 14. (*Square root theorem*): be $\mathbf{L} \in \text{Sym}(\mathcal{V})$ and positive definite; then is exists a unique tensor $\mathbf{U} \in \text{Sym}(\mathcal{V})$ and positive definite such that

$$\mathbf{L} = \mathbf{U}^2.$$

Proof. Existence: be $\mathbf{L}, \mathbf{U}, \mathbf{V} \in \text{Sym}(\mathcal{V})$ positive definite and

$$\mathbf{L} = \omega_i \mathbf{e}_i \otimes \mathbf{e}_i$$

a spectral decomposition of \mathbf{L} , $\omega_i > 0 \forall i$. Define \mathbf{U} as

$$\mathbf{U} = \sqrt{\omega_i} \mathbf{e}_i \otimes \mathbf{e}_i;$$

then, by eq. (2.4)₁ we get

$$\mathbf{U}^2 = \mathbf{L}.$$

Uniqueness: suppose that also

$$\mathbf{V}^2 = \mathbf{L}$$

and be \mathbf{e} an eigenvector of \mathbf{L} corresponding to the (positive) eigenvalue ω . Then, if $\lambda = \sqrt{\omega}$,

$$\mathbf{0} = (\mathbf{U}^2 - \lambda \mathbf{I})\mathbf{e} = (\mathbf{U} - \lambda \mathbf{I})(\mathbf{U} + \lambda \mathbf{I})\mathbf{e},$$

and put

$$\mathbf{v} = (\mathbf{U} - \lambda \mathbf{I})\mathbf{e},$$

we get

$$\mathbf{U}\mathbf{v} = -\lambda\mathbf{v} \Rightarrow \mathbf{v} = \mathbf{0} \Rightarrow \mathbf{U}\mathbf{e} = \lambda\mathbf{e}$$

because \mathbf{U} is positive definite and $-\lambda$ cannot be an eigenvalue of \mathbf{U} , because $\lambda > 0$. In the same way

$$\mathbf{V}\mathbf{e} = \lambda\mathbf{e} \Rightarrow \mathbf{U}\mathbf{e} = \mathbf{V}\mathbf{e}$$

for every eigenvector \mathbf{e} of \mathbf{L} . Because, spectral theorem, it exists a basis of eigenvectors of \mathbf{L} , $\mathbf{U} = \mathbf{V}$. \square

We symbolically write that

$$\mathbf{U} = \sqrt{\mathbf{L}}.$$

For any $\mathbf{F} \in \text{Lin}(\mathcal{V})$, both $\mathbf{F}\mathbf{F}^\top$ and $\mathbf{F}^\top\mathbf{F}$ clearly $\in \text{Sym}(\mathcal{V})$. If in addition $\det \mathbf{F} > 0$, then

$$\mathbf{u} \cdot \mathbf{F}^\top\mathbf{F}\mathbf{u} = (\mathbf{F}\mathbf{u}) \cdot (\mathbf{F}\mathbf{u}) \geq 0$$

and the zero value is obtained $\iff \mathbf{F}\mathbf{u} = \mathbf{0}$ and because \mathbf{F} is invertible, $\iff \mathbf{u} = \mathbf{0}$. As a consequence, $\mathbf{F}^\top\mathbf{F}$ is positive definite. In the same way it can be proved that $\mathbf{F}\mathbf{F}^\top$ is also positive definite.

An important tensor decomposition is given by the

Theorem 15. (*Polar decomposition theorem*): $\forall \mathbf{F} \in \text{Lin}(\mathcal{V}) \mid \det \mathbf{F} > 0$ exist and are uniquely determined two positive definite tensors $\mathbf{U}, \mathbf{V} \in \text{Sym}(\mathcal{V})$ and a rotation \mathbf{R} such that

$$\mathbf{F} = \mathbf{R}\mathbf{U} = \mathbf{V}\mathbf{R}.$$

Proof. Uniqueness: Be $\mathbf{F} = \mathbf{R}\mathbf{U}$ a right polar decomposition of \mathbf{F} ; because $\mathbf{R} \in \text{Orth}(\mathcal{V})^+$ and $\mathbf{U} \in \text{Sym}(\mathcal{V})$,

$$\mathbf{F}^\top \mathbf{F} = \mathbf{U}\mathbf{R}^\top \mathbf{R}\mathbf{U} = \mathbf{U}^2 \rightarrow \mathbf{U} = \sqrt{\mathbf{F}^\top \mathbf{F}}.$$

By the Square-root Theorem, tensor \mathbf{U} is unique, and because

$$\mathbf{R} = \mathbf{F}\mathbf{U}^{-1},$$

\mathbf{R} is unique too.

Be now $\mathbf{F} = \mathbf{V}\mathbf{R}$ a left polar decomposition of \mathbf{F} ; by the same procedure, we get

$$\mathbf{F}\mathbf{F}^\top = \mathbf{V}^2 \rightarrow \mathbf{V} = \sqrt{\mathbf{F}\mathbf{F}^\top},$$

so \mathbf{V} is unique and also

$$\mathbf{R} = \mathbf{V}^{-1}\mathbf{F}.$$

Existence: be

$$\mathbf{U} = \sqrt{\mathbf{F}^\top \mathbf{F}}$$

so $\mathbf{U} \in \text{Sym}(\mathcal{V})$ and it is positive definite, and let

$$\mathbf{R} = \mathbf{F}\mathbf{U}^{-1}.$$

To prove that $\mathbf{F} = \mathbf{R}\mathbf{U}$ is a right polar decomposition, we just have to show that $\mathbf{R} \in \text{Orth}(\mathcal{V})^+$. Since $\det \mathbf{F} > 0, \det \mathbf{U} > 0$ (the latter because all the eigenvalues of \mathbf{U} are strictly positive), by the Theorem of Binet also $\det \mathbf{R} > 0$. Then

$$\mathbf{R}^\top \mathbf{R} = (\mathbf{F}\mathbf{U}^{-1})^\top (\mathbf{F}\mathbf{U}^{-1}) = \mathbf{U}^{-1} \mathbf{F}^\top \mathbf{F} \mathbf{U}^{-1} = \mathbf{U}^{-1} \mathbf{U}^2 \mathbf{U}^{-1} = \mathbf{I} \Rightarrow \mathbf{R} \in \text{Orth}(\mathcal{V})^+.$$

Let now

$$\mathbf{V} = \mathbf{R}\mathbf{U}\mathbf{R}^\top;$$

then $\mathbf{V} \in \text{Sym}(\mathcal{V})$ and is positive definite, see exercise 16, and

$$\mathbf{V}\mathbf{R} = \mathbf{R}\mathbf{U}\mathbf{R}^\top \mathbf{R} = \mathbf{R}\mathbf{U} = \mathbf{F},$$

which completes the proof. □

2.14 Exercises

1. Prove that

$$\mathbf{L}\mathbf{o} = \mathbf{o} \quad \forall \mathbf{L} \in Lin(\mathcal{V}).$$

2. Prove that, if a straight line r has the direction of $\mathbf{u} \in \mathcal{S}$, then the tensor giving the projection of a vector $\mathbf{v} \in \mathcal{V}$ on r is $\mathbf{u} \otimes \mathbf{u}$, while the one giving the projection on a direction orthogonal to r is $\mathbf{I} - \mathbf{u} \otimes \mathbf{u}$.

3. For any $\alpha \in \mathbb{R}$, $\mathbf{a}, \mathbf{b} \in \mathcal{V}$ and $\mathbf{A}, \mathbf{B} \in Lin(\mathcal{V})$, prove that

$$(\alpha \mathbf{A})^\top = \alpha \mathbf{A}^\top, \quad (\mathbf{A} + \mathbf{B})^\top = \mathbf{A}^\top + \mathbf{B}^\top, \quad (\mathbf{a} \otimes \mathbf{b})\mathbf{A} = \mathbf{a} \otimes (\mathbf{A}^\top \mathbf{b}).$$

4. Prove that

$$\text{tr} \mathbf{I} = 3, \quad \text{tr} \mathbf{O} = 0, \quad \text{tr}(\mathbf{A}\mathbf{B}) = \text{tr}(\mathbf{B}\mathbf{A}) \quad \forall \mathbf{A}, \mathbf{B} \in Lin(\mathcal{V}).$$

5. Prove that, $\forall \mathbf{L}, \mathbf{M}, \mathbf{N} \in Lin(\mathcal{V})$,

$$\mathbf{L}^\top \cdot \mathbf{M}^\top = \mathbf{L} \cdot \mathbf{M}, \quad \mathbf{L}\mathbf{M} \cdot \mathbf{N} = \mathbf{L} \cdot \mathbf{N}\mathbf{M}^\top = \mathbf{M} \cdot \mathbf{L}^\top \mathbf{N}.$$

6. Prove that $Sym(\mathcal{V})$ and $Skw(\mathcal{V})$ are orthogonal, i.e. prove that

$$\mathbf{A} \cdot \mathbf{B} = 0 \quad \forall \mathbf{A} \in Sym(\mathcal{V}), \quad \mathbf{B} \in Skw(\mathcal{V}).$$

7. For any $\mathbf{L} \in Lin(\mathcal{V})$, prove that, if $\mathbf{A} \in Sym(\mathcal{V})$, then

$$\mathbf{A} \cdot \mathbf{L} = \mathbf{A} \cdot \mathbf{L}^s,$$

while if $\mathbf{B} \in Skw(\mathcal{V})$, then

$$\mathbf{B} \cdot \mathbf{L} = \mathbf{B} \cdot \mathbf{L}^a.$$

8. Express by components the second principal invariant I_2 of a tensor \mathbf{L} .

9. Prove that, if $\mathbf{a} = (a_1, a_2, a_3)$, $\mathbf{b} = (b_1, b_2, b_3)$, $\mathbf{c} = (c_1, c_2, c_3)$, then

$$\mathbf{a} \times \mathbf{b} \cdot \mathbf{c} = \det \begin{bmatrix} a_1 & a_2 & a_3 \\ b_1 & b_2 & b_3 \\ c_1 & c_2 & c_3 \end{bmatrix}.$$

10. Prove the uniqueness of the inverse tensor.

11. Show, using the Cartesian components, that all the dyads are singular.

12. Prove that if \mathbf{L} is invertible and $\alpha \in \mathbb{R} - \{0\}$ then

$$(\alpha \mathbf{L})^{-1} = \alpha^{-1} \mathbf{L}^{-1}.$$

13. Prove that any form defined by a tensor \mathbf{L} can be written as a scalar product of tensors:

$$\mathbf{v} \cdot \mathbf{L}\mathbf{w} = \mathbf{L} \cdot \mathbf{v} \otimes \mathbf{w} \quad \forall \mathbf{v}, \mathbf{w} \in \mathcal{V}, \mathbf{L} \in \text{Lin}(\mathcal{V}).$$

14. Prove that, if \mathbf{W} is the axial tensor of \mathbf{w} , then

$$\mathbf{W}\mathbf{W} = -\frac{1}{2}|\mathbf{W}|^2(\mathbf{I} - \mathbf{w} \otimes \mathbf{w}).$$

15. Prove that for any two axial couples $\mathbf{w}_1, \mathbf{W}_1$ and $\mathbf{w}_2, \mathbf{W}_2$, it is:

$$\mathbf{w}_1 \cdot \mathbf{w}_2 = \frac{1}{2}\mathbf{W}_1 \cdot \mathbf{W}_2.$$

16. Let $\mathbf{L} \in \text{Sym}(\mathcal{V})$ and positive definite and $\mathbf{R} \in \text{Orth}(\mathcal{V})^+$; then prove that $\mathbf{R}\mathbf{L}\mathbf{R}^\top \in \text{Sym}(\mathcal{V})$ and that it is positive definite.

17. Let $\mathbf{A}, \mathbf{B}, \mathbf{C}, \mathbf{D} \in \text{Lin}(\mathcal{V})$; prove that

$$\mathbf{A} \cdot (\mathbf{BCD}) = (\mathbf{B}^\top \mathbf{A}) \cdot (\mathbf{CD}) = (\mathbf{AD}^\top) \cdot (\mathbf{BC}).$$

18. Prove that the spectrum of \mathbf{L}^{sph} is composed by only

$$\lambda^{sph} = \frac{1}{3}\text{tr}\mathbf{L},$$

and that any $\mathbf{u} \in \mathcal{S}$ is an eigenvector.

19. Prove that the eigenvalues λ^{dev} of \mathbf{L}^{dev} are given by

$$\lambda^{dev} = \lambda - \lambda^{sph},$$

where λ is an eigenvalue of \mathbf{L} .

Chapter 3

Fourth rank tensors

3.1 Fourth-rank tensors

A *fourth-rank tensor* \mathbb{L} is any linear application from $Lin(\mathcal{V})$ to $Lin(\mathcal{V})$:

$$\mathbb{L} : Lin(\mathcal{V}) \rightarrow Lin(\mathcal{V}) | \mathbb{L}(\alpha_i \mathbf{A}_i) = \alpha_i \mathbb{L} \mathbf{A}_i \quad \forall \alpha_i \in \mathbb{R}, \mathbf{A}_i \in Lin(\mathcal{V}), i = 1, \dots, n.$$

Defining the *sum of two fourth-rank tensors* as

$$(\mathbb{L}_1 + \mathbb{L}_2) \mathbf{A} = \mathbb{L}_1 \mathbf{A} + \mathbb{L}_2 \mathbf{A} \quad \forall \mathbf{A} \in Lin(\mathcal{V}),$$

the *product of a scalar by a fourth-rank tensor* as

$$(\alpha \mathbb{L}) \mathbf{A} = \alpha (\mathbb{L} \mathbf{A}) \quad \forall \alpha \in \mathbb{R}, \mathbf{A} \in Lin(\mathcal{V})$$

and the *null fourth-rank tensor* \mathbb{O} as the unique tensor such that

$$\mathbb{O} \mathbf{A} = \mathbf{O} \quad \forall \mathbf{A} \in Lin(\mathcal{V}),$$

then the set of all the tensors \mathbb{L} that operate on $Lin(\mathcal{V})$ forms a vector space, denoted by $\mathbb{L}in(\mathcal{V})$. We define the *fourth-rank identity tensor* \mathbb{I} as the unique tensor such that

$$\mathbb{I} \mathbf{A} = \mathbf{A} \quad \forall \mathbf{A} \in Lin(\mathcal{V}).$$

It is apparent that the algebra of fourth-rank tensors is similar to that of second-rank tensors and in fact the operations with fourth-rank tensors can be introduced in almost the same way, in some sense shifting from \mathcal{V} to $Lin(\mathcal{V})$ the operations. However, the algebra of fourth-rank tensors is richer than that of the second-rank ones and some care must be paid.

In the following sections, we consider some of the operations that can be done with fourth-rank tensors.

3.2 Dyads, tensor components

For any couple of tensors \mathbf{A} and $\mathbf{B} \in \text{Lin}(\mathcal{V})$, the (*tensor*) *dyad* $\mathbf{A} \otimes \mathbf{B}$ is the fourth-rank tensor defined by

$$(\mathbf{A} \otimes \mathbf{B})\mathbf{L} := \mathbf{B} \cdot \mathbf{L} \mathbf{A} \quad \forall \mathbf{L} \in \text{Lin}(\mathcal{V}).$$

The application defined above is actually a fourth-rank tensor because of the bi-linearity of the scalar product of second-rank tensors. Applying this rule to the nine dyads of the basis $\mathcal{B}^2 = \{\mathbf{e}_i \otimes \mathbf{e}_j, i, j = 1, 2, 3\}$ of $\text{Lin}(\mathcal{V})$ let us introduce the 81 fourth-rank tensors

$$\mathbf{e}_i \otimes \mathbf{e}_j \otimes \mathbf{e}_k \otimes \mathbf{e}_l := (\mathbf{e}_i \otimes \mathbf{e}_j) \otimes (\mathbf{e}_k \otimes \mathbf{e}_l)$$

that form a basis $\mathcal{B}^4 = \{\mathbf{e}_i \otimes \mathbf{e}_j \otimes \mathbf{e}_k \otimes \mathbf{e}_l, i, j = 1, 2, 3\}$ for $\mathbb{L}(\mathcal{V})$. We remark hence that $\dim(\mathbb{L}(\mathcal{V})) = 81$. A useful result is that

$$(\mathbf{e}_i \otimes \mathbf{e}_j \otimes \mathbf{e}_k \otimes \mathbf{e}_l)(\mathbf{e}_p \otimes \mathbf{e}_q) = (\mathbf{e}_k \otimes \mathbf{e}_l) \cdot (\mathbf{e}_p \otimes \mathbf{e}_q)(\mathbf{e}_i \otimes \mathbf{e}_j) = \delta_{kp}\delta_{lq}(\mathbf{e}_i \otimes \mathbf{e}_j). \quad (3.1)$$

Any fourth-rank tensor can be expressed as the linear combination (the *canonical decomposition*)

$$\mathbb{L} = L_{ijkl} \mathbf{e}_i \otimes \mathbf{e}_j \otimes \mathbf{e}_k \otimes \mathbf{e}_l, \quad i, j = 1, 2, 3,$$

where the L_{ijkl} s are the 81 *Cartesian components* of \mathbb{L} with respect to \mathcal{B}^4 . The L_{ijkl} s are defined by the operation:

$$\begin{aligned} (\mathbf{e}_i \otimes \mathbf{e}_j) \cdot \mathbb{L}(\mathbf{e}_k \otimes \mathbf{e}_l) &= (\mathbf{e}_i \cdot \mathbf{e}_j) \cdot (L_{pqrs} \mathbf{e}_p \otimes \mathbf{e}_q \otimes \mathbf{e}_r \otimes \mathbf{e}_s)(\mathbf{e}_k \otimes \mathbf{e}_l) \\ &= (\mathbf{e}_i \otimes \mathbf{e}_j) \cdot (L_{pqrs} \delta_{rk} \delta_{sl} \mathbf{e}_p \otimes \mathbf{e}_q) \\ &= L_{pqrs} \delta_{rk} \delta_{sl} \delta_{ip} \delta_{jq} = L_{ijkl}. \end{aligned}$$

The components of a tensor dyad can be computed without any difficulty:

$$\begin{aligned} \mathbf{A} \otimes \mathbf{B} &= (A_{ij} \mathbf{e}_i \otimes \mathbf{e}_j) \otimes (B_{kl} \mathbf{e}_k \otimes \mathbf{e}_l) = A_{ij} B_{kl} \mathbf{e}_i \otimes \mathbf{e}_j \otimes \mathbf{e}_k \otimes \mathbf{e}_l \Rightarrow \\ &(\mathbf{A} \otimes \mathbf{B})_{ijkl} = A_{ij} B_{kl}, \end{aligned}$$

so that in particular

$$((\mathbf{a} \otimes \mathbf{b}) \otimes (\mathbf{c} \otimes \mathbf{d}))_{ijkl} = a_i b_j c_k d_l.$$

Concerning the identity of $\mathbb{L}(\mathcal{V})$,

$$\begin{aligned} I_{ijkl} &:= (\mathbf{e}_i \otimes \mathbf{e}_l) \cdot \mathbb{I}(\mathbf{e}_k \otimes \mathbf{e}_l) = (\mathbf{e}_i \otimes \mathbf{e}_j) \cdot (\mathbf{e}_k \otimes \mathbf{e}_l) = \mathbf{e}_i \cdot \mathbf{e}_k \mathbf{e}_j \cdot \mathbf{e}_l = \delta_{ik} \delta_{jl} \rightarrow \\ &\mathbb{I} = \delta_{ik} \delta_{jl} (\mathbf{e}_i \otimes \mathbf{e}_l \otimes \mathbf{e}_k \otimes \mathbf{e}_l). \end{aligned}$$

The components of $\mathbf{A} \in \text{Lin}(\mathcal{V})$ result of the application of $\mathbb{L} \in \mathbb{L}(\mathcal{V})$ on $\mathbf{B} \in \text{Lin}(\mathcal{V})$ can now be easily calculated:

$$\begin{aligned} \mathbf{A} = \mathbb{L}\mathbf{B} &= L_{ijkl} (\mathbf{e}_i \otimes \mathbf{e}_j \otimes \mathbf{e}_k \otimes \mathbf{e}_l) (B_{pq} \mathbf{e}_p \otimes \mathbf{e}_q) \\ &= L_{ijkl} B_{pq} \delta_{kp} \delta_{lq} (\mathbf{e}_i \otimes \mathbf{e}_j) \\ &= L_{ijkl} B_{kl} (\mathbf{e}_i \otimes \mathbf{e}_j) \rightarrow A_{ij} = L_{ijkl} B_{kl}. \end{aligned} \quad (3.2)$$

Moreover,

$$\begin{aligned} \mathbb{L}(\mathbf{A} \otimes \mathbf{B})\mathbf{C} &= \mathbb{L}((\mathbf{A} \otimes \mathbf{B})\mathbf{C}) = \mathbb{L}(\mathbf{B} \cdot \mathbf{C}\mathbf{A}) = \mathbf{B} \cdot \mathbf{C} \mathbb{L}\mathbf{A} = ((\mathbf{L}\mathbf{A}) \otimes \mathbf{B})\mathbf{C} \Rightarrow \\ &\mathbb{L}(\mathbf{A} \otimes \mathbf{B}) = (\mathbf{L}\mathbf{A}) \otimes \mathbf{B}. \end{aligned}$$

Using this result and eq. (3.1), we can determine the components of a product of fourth-rank tensors:

$$\begin{aligned}
\mathbb{A}\mathbb{B} &= A_{ijkl}(\mathbf{e}_i \otimes \mathbf{e}_j \otimes \mathbf{e}_k \otimes \mathbf{e}_l)B_{pqrs}(\mathbf{e}_p \otimes \mathbf{e}_q \otimes \mathbf{e}_r \otimes \mathbf{e}_s) \\
&= A_{ijkl}B_{pqrs}(\mathbf{e}_i \otimes \mathbf{e}_j \otimes \mathbf{e}_k \otimes \mathbf{e}_l)(\mathbf{e}_p \otimes \mathbf{e}_q) \otimes (\mathbf{e}_r \otimes \mathbf{e}_s) \\
&= A_{ijkl}B_{pqrs}[(\mathbf{e}_i \otimes \mathbf{e}_j \otimes \mathbf{e}_k \otimes \mathbf{e}_l)(\mathbf{e}_p \otimes \mathbf{e}_q)] \otimes (\mathbf{e}_r \otimes \mathbf{e}_s) \\
&= A_{ijkl}B_{pqrs}[\delta_{kp}\delta_{lq}(\mathbf{e}_i \otimes \mathbf{e}_j)] \otimes (\mathbf{e}_r \otimes \mathbf{e}_s) \\
&= A_{ijkl}B_{klrs}(\mathbf{e}_i \otimes \mathbf{e}_j \otimes \mathbf{e}_r \otimes \mathbf{e}_s) \Rightarrow (\mathbb{A}\mathbb{B})_{ijrs} = A_{ijkl}B_{klrs}.
\end{aligned} \tag{3.3}$$

Depending upon four indices, a fourth-rank tensor \mathbb{L} cannot be represented by a matrix; however, we will see in Sect. 3.8 that a matrix representation of a fourth-rank tensor is still possible, and that it is currently used in some cases, e.g. in elasticity.

3.3 Conjugation product, transpose, symmetries

For any two tensors $\mathbf{A}, \mathbf{B} \in \text{Lin}(\mathcal{V})$ we call *conjugation product* the the tensor $\mathbf{A} \boxtimes \mathbf{B} \in \text{Lin}(\mathcal{V})$ defined by the operation

$$(\mathbf{A} \boxtimes \mathbf{B})\mathbf{L} := \mathbf{A}\mathbf{L}\mathbf{B}^\top \quad \forall \mathbf{L} \in \text{Lin}(\mathcal{V}).$$

As a consequence, for the vectors of \mathcal{B} ,

$$(\mathbf{e}_i \otimes \mathbf{e}_j) \boxtimes (\mathbf{e}_k \otimes \mathbf{e}_l) = \mathbf{e}_i \otimes \mathbf{e}_k \otimes \mathbf{e}_j \otimes \mathbf{e}_l, \tag{3.4}$$

so that

$$(\mathbf{A} \boxtimes \mathbf{B})_{ijkl} = A_{ik}B_{jl}.$$

Moreover, by the uniqueness of the identity \mathbb{I} , $\forall \mathbf{A} \in \text{Lin}(\mathcal{V})$,

$$(\mathbb{I} \boxtimes \mathbb{I})\mathbf{A} = \mathbf{A}\mathbb{I}\mathbb{I}^\top = \mathbf{A} \Rightarrow \mathbb{I} = \mathbb{I} \boxtimes \mathbb{I}.$$

The *transpose* of a fourth-rank tensor \mathbb{L} is the unique tensor \mathbb{L}^\top such that

$$\mathbf{A} \cdot (\mathbb{L}\mathbf{B}) = \mathbf{B} \cdot (\mathbb{L}^\top \mathbf{A}) \quad \forall \mathbf{A}, \mathbf{B} \in \text{Lin}(\mathcal{V}).$$

By this definition, putting $\mathbf{A} = \mathbf{e}_i \otimes \mathbf{e}_j$, $\mathbf{B} = \mathbf{e}_k \otimes \mathbf{e}_l$ gives

$$(L^\top)_{ijkl} = L_{klji}.$$

A consequence is that

$$\mathbf{A} \cdot (\mathbb{L}\mathbf{B}) = \mathbf{B} \cdot (\mathbb{L}^\top \mathbf{A}) = \mathbf{A} \cdot (\mathbb{L}^\top)^\top \mathbf{B} \Rightarrow (\mathbb{L}^\top)^\top = \mathbb{L}.$$

Then, using

$$\begin{aligned}
\mathbf{M} \cdot (\mathbf{A} \otimes \mathbf{B})^\top \mathbf{L} &= \mathbf{L} \cdot (\mathbf{A} \otimes \mathbf{B})\mathbf{M} \\
&= \mathbf{L} \cdot \mathbf{A}\mathbf{M} \cdot \mathbf{B} = \mathbf{M} \cdot (\mathbf{B}\mathbf{A} \cdot \mathbf{L}) \\
&= \mathbf{M} \cdot (\mathbf{B} \otimes \mathbf{A})\mathbf{L}, \\
\mathbf{M} \cdot (\mathbf{A} \boxtimes \mathbf{B})^\top \mathbf{L} &= \mathbf{L} \cdot (\mathbf{A} \boxtimes \mathbf{B})\mathbf{M} \\
&= \mathbf{L} \cdot \mathbf{A}\mathbf{M}\mathbf{B}^\top = \mathbf{A}^\top \mathbf{L} \cdot \mathbf{M}\mathbf{B}^\top = \mathbf{M}^\top \mathbf{A}^\top \mathbf{L} \cdot \mathbf{B}^\top \\
&= (\mathbf{M}^\top \mathbf{A}^\top \mathbf{L})^\top \cdot (\mathbf{B}^\top)^\top = \mathbf{L}^\top \mathbf{A}\mathbf{M} \cdot \mathbf{B} = \mathbf{A}\mathbf{M} \cdot \mathbf{L}\mathbf{B} \\
&= \mathbf{M} \cdot \mathbf{A}^\top \mathbf{L}\mathbf{B} = \mathbf{M} \cdot (\mathbf{A}^\top \boxtimes \mathbf{B}^\top)\mathbf{L},
\end{aligned}$$

so that

$$\begin{aligned}(\mathbf{A} \otimes \mathbf{B})^\top &= \mathbf{B} \otimes \mathbf{A}, \\ (\mathbf{A} \boxtimes \mathbf{B})^\top &= \mathbf{A}^\top \boxtimes \mathbf{B}^\top.\end{aligned}$$

A tensor $\mathbb{L} \in \text{Lin}(\mathcal{V})$ is *symmetric* $\iff \mathbb{L} = \mathbb{L}^\top$. It is then evident that

$$\mathbb{L} = \mathbb{L}^\top \Rightarrow L_{ijkl} = L_{klij},$$

relations called *major symmetries*. These symmetries are 36 on the whole, so that a symmetric fourth-rank tensor has 45 independent components. Moreover,

$$\begin{aligned}\mathbf{A} \boxtimes \mathbf{B} = (\mathbf{A} \boxtimes \mathbf{B})^\top &= \mathbf{A}^\top \boxtimes \mathbf{B}^\top \iff \mathbf{A} = \mathbf{A}^\top, \mathbf{B} = \mathbf{B}^\top, \\ \mathbf{A} \otimes \mathbf{B} = (\mathbf{A} \otimes \mathbf{B})^\top &= \mathbf{B} \otimes \mathbf{A} \iff \mathbf{B} = \lambda \mathbf{A}, \lambda \in \mathbb{R}.\end{aligned}$$

Let us now consider the case of a $\mathbb{L} \in \text{Lin}(\mathcal{V})$ such that

$$\mathbb{L}\mathbf{A} = (\mathbb{L}\mathbf{A})^\top \quad \forall \mathbf{A} \in \text{Lin}(\mathcal{V}).$$

Then, by eq. (3.2),

$$L_{ijkl} = L_{jikl},$$

relations called *left minor symmetries*: a tensor \mathbb{L} having the left minor symmetries has values in $\text{Sym}(\mathcal{V})$. On the whole, the left minor symmetries are 27. Finally, consider the case of a $\mathbb{L} \in \text{Lin}(\mathcal{V})$ such that

$$\mathbb{L}\mathbf{A} = \mathbb{L}(\mathbf{A}^\top) \quad \forall \mathbf{A} \in \text{Lin}(\mathcal{V});$$

then, again by eq. (3.2), we get

$$L_{ijlk} = L_{jilk},$$

relations called *minor right-symmetries*, whose total number is also 27. It is immediate to recognize that if \mathbb{L} has the minor right-symmetries, then

$$\mathbb{L}\mathbf{W} = \mathbf{O} \quad \forall \mathbf{W} \in \text{Skw}(\mathcal{V}).$$

We say that a tensor has the minor symmetries if it has both the right and left minor symmetries; the total number of minor symmetries is 45, because actually some of the left and right minor symmetries are the same, so a tensor with the minor symmetries has 36 independent components.

If $\mathbb{L} \in \text{Lin}(\mathcal{V})$ has the major and minor symmetries, then the independent symmetry relations are actually 60 (some minor and major symmetries coincide), so in such a case \mathbb{L} depends upon 21 independent components only. This is the case of the elasticity tensor.

Finally, the 6 *Cauchy-Poisson symmetries* are those of the type

$$L_{ijkl} = L_{ikjl}.$$

A tensor having the major, minor and Cauchy-Poisson symmetries is *completely symmetric*, i.e. swapping any couple of indices gives an identical component. In that case, the number of independent components is of only 15.

3.4 Trace and scalar product of fourth-rank tensors

We can introduce the scalar product between fourth-rank tensors in the same way used for second-rank tensors. We first introduce the concept of *trace for fourth-rank tensors* once again using the dyad (here, the tensor dyad):

$$\mathrm{tr}_4 \mathbf{A} \otimes \mathbf{B} := \mathbf{A} \cdot \mathbf{B}.$$

The easy proof that $\mathrm{tr}_4 : \mathbb{L}(\mathcal{V}) \rightarrow \mathbb{R}$ is a linear form is based upon the properties of scalar product of second-rank tensors and it is left to the reader. An immediate result is that

$$\mathrm{tr}_4 \mathbf{A} \otimes \mathbf{B} = A_{ij} B_{ij},$$

Then, using the canonical decomposition, we have that

$$\mathrm{tr}_4 \mathbb{L} = \mathrm{tr}_4(L_{ijkl}(\mathbf{e}_i \otimes \mathbf{e}_j) \otimes (\mathbf{e}_k \otimes \mathbf{e}_l)) = L_{ijkl}(\mathbf{e}_i \otimes \mathbf{e}_j) \cdot (\mathbf{e}_k \otimes \mathbf{e}_l) = L_{ijkl} \delta_{ik} \delta_{jl} = L_{ijij}$$

and that

$$\mathrm{tr}_4 \mathbb{L}^\top = \mathrm{tr}_4(L_{klij}(\mathbf{e}_i \otimes \mathbf{e}_j) \otimes (\mathbf{e}_k \otimes \mathbf{e}_l)) = L_{klij}(\mathbf{e}_i \otimes \mathbf{e}_j) \cdot (\mathbf{e}_k \otimes \mathbf{e}_l) = L_{klij} \delta_{ik} \delta_{jl} = L_{ijij} = \mathrm{tr}_4 \mathbb{L}.$$

Then, we define the *scalar product of fourth-rank tensors* as

$$\mathbf{A} \cdot \mathbf{B} := \mathrm{tr}_4(\mathbf{A}^\top \mathbf{B}).$$

By the properties of tr_4 , the scalar product is a positive definite symmetric bilinear form:

$$\begin{aligned} \alpha \mathbf{A} \cdot \beta \mathbf{B} &= \mathrm{tr}_4(\alpha \mathbf{A}^\top \beta \mathbf{B}) = \alpha \beta \mathrm{tr}_4(\mathbf{A}^\top \mathbf{B}) = \alpha \beta \mathbf{A} \cdot \mathbf{B}, \\ \mathbf{A} \cdot \mathbf{B} &= \mathrm{tr}_4(\mathbf{A}^\top \mathbf{B}) = \mathrm{tr}_4(\mathbf{A}^\top \mathbf{B})^\top = \mathrm{tr}_4(\mathbf{B}^\top \mathbf{A}) = \mathbf{B} \cdot \mathbf{A}, \\ \mathbf{A} \cdot \mathbf{A} &= \mathrm{tr}_4(\mathbf{A}^\top \mathbf{A}) = (\mathbf{A}^\top \mathbf{A})_{ijij} = A_{klij} A_{klij} > 0 \quad \forall \mathbf{A} \in \mathbb{L}(\mathcal{V}), \mathbf{A} \cdot \mathbf{A} = 0 \iff \mathbf{A} = \mathbf{0}. \end{aligned}$$

By components

$$\begin{aligned} \mathbf{A} \cdot \mathbf{B} &= \mathrm{tr}_4((A_{klij} \mathbf{e}_i \otimes \mathbf{e}_j \otimes \mathbf{e}_k \otimes \mathbf{e}_l)(B_{pqrs} \mathbf{e}_p \otimes \mathbf{e}_q \otimes \mathbf{e}_r \otimes \mathbf{e}_s)) \\ &= \mathrm{tr}_4(A_{klij} B_{pqrs} \delta_{kp} \delta_{lq} (\mathbf{e}_i \otimes \mathbf{e}_j) \otimes (\mathbf{e}_r \otimes \mathbf{e}_s)) \\ &= A_{klij} B_{pqrs} \delta_{kp} \delta_{lq} (\mathbf{e}_i \otimes \mathbf{e}_j) \cdot (\mathbf{e}_r \otimes \mathbf{e}_s) = A_{klij} B_{pqrs} \delta_{kp} \delta_{lq} \delta_{ir} \delta_{js} = A_{klij} B_{klij}. \end{aligned}$$

The rule for computing the scalar product is hence always the same already seen for vectors and second-rank tensors: all the indexes are to be saturated.

In complete analogy with vectors and second-rank tensors, we say that \mathbf{A} is *orthogonal to* \mathbf{B} \iff

$$\mathbf{A} \cdot \mathbf{B} = 0$$

and we define the *norm of* \mathbb{L} as

$$|\mathbb{L}| := \sqrt{\mathbb{L} \cdot \mathbb{L}} = \sqrt{\mathrm{tr}_4 \mathbb{L}^\top \mathbb{L}} = \sqrt{L_{ijkl} L_{ijkl}}.$$

3.5 Projectors, identities

For the spherical part of any $\mathbf{A} \in \text{Sym}(\mathcal{V})$ we can write

$$\mathbf{A}^{sph} := \frac{1}{3} \text{tr} \mathbf{A} \mathbf{I} = \frac{1}{3} \mathbf{I} \cdot \mathbf{A} \mathbf{I} = \frac{1}{3} (\mathbf{I} \otimes \mathbf{I}) \mathbf{A} = \mathbb{S}^{sph} \mathbf{A},$$

where

$$\mathbb{S}^{sph} := \frac{1}{3} \mathbf{I} \otimes \mathbf{I}$$

is the *spherical projector*, i.e. the fourth-rank tensor that extracts from any $\mathbf{A} \in \text{Lin}(\mathcal{V})$ its spherical part. Moreover,

$$\mathbf{A}^{dev} := \mathbf{A} - \mathbf{A}^{sph} = \mathbb{I} \mathbf{A} - \mathbb{S}^{sph} \mathbf{A} = \mathbb{D}^{dev} \mathbf{A},$$

where

$$\mathbb{D}^{dev} := \mathbb{I} - \mathbb{S}^{sph}$$

is the *deviatoric projector*, i.e. the fourth-rank tensor that extracts from any $\mathbf{A} \in \text{Lin}(\mathcal{V})$ its deviatoric part. It is worth noting that

$$\mathbb{I} = \mathbb{S}^{sph} + \mathbb{D}^{dev}.$$

Moreover, about the components of \mathbb{S}^{sph} ,

$$\begin{aligned} S_{ijkl}^{sph} &= (\mathbf{e}_i \otimes \mathbf{e}_j) \cdot \frac{1}{3} (\mathbf{I} \otimes \mathbf{I}) (\mathbf{e}_k \otimes \mathbf{e}_l) = \frac{1}{3} (\mathbf{e}_i \otimes \mathbf{e}_j) \cdot \mathbf{I} (\mathbf{e}_k \otimes \mathbf{e}_l) \cdot \mathbf{I} \\ &= \frac{1}{3} \text{tr} (\mathbf{e}_i \otimes \mathbf{e}_j) \text{tr} (\mathbf{e}_k \otimes \mathbf{e}_l) = \frac{1}{3} \delta_{ij} \delta_{kl} \rightarrow \mathbb{S}^{sph} = \frac{1}{3} \delta_{ij} \delta_{kl} (\mathbf{e}_i \otimes \mathbf{e}_j \otimes \mathbf{e}_k \otimes \mathbf{e}_l). \end{aligned}$$

To remark that

$$\mathbb{S}^{sph} = (\mathbb{S}^{sph})^\top.$$

We introduce now the tensor \mathbb{I}^s , *restriction of \mathbb{I} to $A \in \text{Sym}(\mathcal{V})$* . It can be introduced as follows: $\forall A \in \text{Sym}(\mathcal{V})$

$$\mathbf{A} = \frac{1}{2} (\mathbf{A} + \mathbf{A}^\top),$$

and

$$\mathbf{A} = \mathbb{I} \mathbf{A} = \frac{1}{2} (\mathbb{I} \mathbf{A} + \mathbb{I} \mathbf{A}^\top) = \frac{1}{2} (I_{ijkl} A_{kl} + I_{ijlk} A_{lk}) (\mathbf{e}_i \otimes \mathbf{e}_j \otimes \mathbf{e}_k \otimes \mathbf{e}_l);$$

because $\mathbf{A} = \mathbf{A}^\top$ there is insensitivity to the swap of indexes k and l , so

$$\mathbf{A} = \frac{1}{2} (I_{ijkl} A_{kl} + I_{ijlk} A_{lk}) (\mathbf{e}_i \otimes \mathbf{e}_j \otimes \mathbf{e}_k \otimes \mathbf{e}_l) = \frac{1}{2} (\delta_{ik} \delta_{jl} + \delta_{il} \delta_{jk}) A_{kl} (\mathbf{e}_i \otimes \mathbf{e}_j \otimes \mathbf{e}_k \otimes \mathbf{e}_l).$$

Then, if we admit the interchangeability of indexes k and l , i.e. if we postulate the existence of the minor right-symmetries for \mathbb{I} , then $\mathbb{I} = \mathbb{I}^s$, with

$$\mathbb{I}^s = \frac{1}{2} (\delta_{ik} \delta_{jl} + \delta_{il} \delta_{jk}) (\mathbf{e}_i \otimes \mathbf{e}_j \otimes \mathbf{e}_k \otimes \mathbf{e}_l).$$

It is apparent that

$$I_{ijkl}^s = I_{klij}^s,$$

i.e. $\mathbb{I}^s = (\mathbb{I}^s)^\top$, but also that

$$I_{ijkl}^s = \frac{1}{2}(\delta_{il}\delta_{jk} + \delta_{ik}\delta_{jl}) = I_{jikl}^s,$$

i.e., \mathbb{I}^s has also the minor left-symmetries; in other words, \mathbb{I}^s has the major and minor symmetries, like an elasticity tensor, while this is not the case for \mathbb{I} . In fact

$$I_{ijkl} = I_{jilk} = \delta_{ik}\delta_{jl} \neq \delta_{il}\delta_{jk} = I_{jikl} = I_{ijlk}.$$

Because \mathbb{S}^{sph} and \mathbb{D}^{dev} operate on $Sym(\mathcal{V})$, it is immediate to recognize that it is also

$$\mathbb{D}^{dev} = \mathbb{I}^s - \mathbb{S}^{sph} \Rightarrow \mathbb{I}^s = \mathbb{S}^{sph} + \mathbb{D}^{dev}.$$

It is worth noting that

$$(\mathbb{D}^{dev})^\top = (\mathbb{I}^s - \mathbb{S}^{sph})^\top = (\mathbb{I}^s)^\top - (\mathbb{S}^{sph})^\top = \mathbb{I}^s - \mathbb{S}^{sph} = \mathbb{D}^{dev}.$$

We can now determine the components of \mathbb{D}^{dev} :

$$\begin{aligned} D_{ijkl}^{dev} &= I_{ijkl}^s - S_{ijkl}^{sph} = \frac{1}{2}(\delta_{ik}\delta_{jl} + \delta_{il}\delta_{jk}) - \frac{1}{3}\delta_{ij}\delta_{kl} \rightarrow \\ \mathbb{D}^{dev} &= \left[\frac{1}{2}(\delta_{ik}\delta_{jl} + \delta_{il}\delta_{jk}) - \frac{1}{3}\delta_{ij}\delta_{kl} \right] (\mathbf{e}_i \otimes \mathbf{e}_j \otimes \mathbf{e}_k \otimes \mathbf{e}_l). \end{aligned}$$

To remark that the result (2.6) implies that \mathbb{S}^{sph} and \mathbb{D}^{dev} are *orthogonal projectors*, i.e. they project the same $\mathbf{A} \in Sym(\mathcal{V})$ into two orthogonal subspaces of \mathcal{V} , $Sph(\mathcal{V})$ and $Dev(\mathcal{V})$.

The tensor $\mathbb{T}^{trp} \in Lin(\mathcal{V})$ defined by the operation

$$\mathbb{T}^{trp} \mathbf{A} := \mathbf{A}^\top,$$

is the *transposition projector*, whose components are

$$T_{ijkl}^{trp} = (\mathbf{e}_i \otimes \mathbf{e}_j) \cdot \mathbb{T}^{trp}(\mathbf{e}_k \otimes \mathbf{e}_l) = (\mathbf{e}_i \otimes \mathbf{e}_j) \cdot (\mathbf{e}_l \otimes \mathbf{e}_k) = \delta_{il}\delta_{jk}.$$

The following operation defines the *symmetry projector* $\mathbb{S}^{sym} \in Lin(\mathcal{V})$:

$$\mathbb{S}^{sym} \mathbf{A} = \frac{1}{2}(\mathbf{A} + \mathbf{A}^\top) \quad \forall \mathbf{A} \in Lin(\mathcal{V}),$$

while the *antisymmetry projector* $\mathbb{W}^{skw} \in Lin(\mathcal{V})$ is defined by

$$\mathbb{W}^{skw} \mathbf{A} = \frac{1}{2}(\mathbf{A} - \mathbf{A}^\top) \quad \forall \mathbf{A} \in Lin(\mathcal{V}).$$

Also \mathbb{S}^{sym} and \mathbb{W}^{skw} are orthogonal projectors, because they project the same $\mathbf{A} \in Lin(\mathcal{V})$ into two orthogonal subspaces of $Lin(\mathcal{V})$: $Sym(\mathcal{V})$ and $Skw(\mathcal{V})$, see exercise 6 of Chap. 2.

We prove now two properties of the projectors: $\forall \mathbf{A} \in \text{Lin}(\mathcal{V})$,

$$(\mathbb{S}^{sym} + \mathbb{W}^{skw})\mathbf{A} = \frac{1}{2}(\mathbf{A} + \mathbf{A}^\top) + \frac{1}{2}(\mathbf{A} - \mathbf{A}^\top) = \mathbf{A} = \mathbb{I}\mathbf{A} \Rightarrow \mathbb{S}^{sym} + \mathbb{W}^{skw} = \mathbb{I}. \quad (3.5)$$

Then,

$$(\mathbb{S}^{sym} - \mathbb{W}^{skw})\mathbf{A} = \frac{1}{2}(\mathbf{A} + \mathbf{A}^\top) - \frac{1}{2}(\mathbf{A} - \mathbf{A}^\top) = \mathbf{A}^\top = \mathbb{T}^{trp}\mathbf{A} \Rightarrow \mathbb{S}^{sym} - \mathbb{W}^{skw} = \mathbb{T}^{trp}. \quad (3.6)$$

3.6 Orthogonal conjugator

For any $\mathbf{U} \in \text{Orth}(\mathcal{V})$ we define its *orthogonal conjugator* $\mathbb{U} \in \text{Lin}(\mathcal{V})$ as

$$\mathbb{U} := \mathbf{U} \boxtimes \mathbf{U}.$$

Theorem 16. (*orthogonality of \mathbb{U}*): the orthogonal conjugator is an orthogonal tensor of $\text{Lin}(\mathcal{V})$, i.e. it preserves the scalar product between tensors:

$$\mathbb{U}\mathbf{A} \cdot \mathbb{U}\mathbf{B} = \mathbf{A} \cdot \mathbf{B} \quad \forall \mathbf{A}, \mathbf{B} \in \text{Lin}(\mathcal{V}).$$

Proof. By the assertion in exercise 17 of Chap. 2, and because $\mathbf{U} \in \text{Orth}(\mathcal{V})$, we have

$$\begin{aligned} \mathbb{U}\mathbf{A} \cdot \mathbb{U}\mathbf{B} &= (\mathbf{U} \boxtimes \mathbf{U})\mathbf{A} \cdot (\mathbf{U} \boxtimes \mathbf{U})\mathbf{B} = \mathbf{U}\mathbf{A}\mathbf{U}^\top \cdot \mathbf{U}\mathbf{B}\mathbf{U}^\top \\ &= \mathbf{U}^\top \mathbf{U}\mathbf{A}\mathbf{U}^\top \cdot \mathbf{U}\mathbf{B}\mathbf{U}^\top = \mathbf{A}\mathbf{U}^\top \cdot \mathbf{B}\mathbf{U}^\top = \mathbf{A}\mathbf{U}^\top \mathbf{U} \cdot \mathbf{B} = \mathbf{A} \cdot \mathbf{B}. \end{aligned}$$

□

Just as for tensors of $\text{Orth}(\mathcal{V})$, it is also

$$\mathbb{U}\mathbb{U}^\top = \mathbb{U}^\top \mathbb{U} = \mathbb{I}.$$

In fact, see the assertion of exercise 3,

$$\mathbb{U}\mathbb{U}^\top = (\mathbf{U} \boxtimes \mathbf{U})(\mathbf{U}^\top \boxtimes \mathbf{U}^\top) = \mathbf{U}\mathbf{U}^\top \boxtimes \mathbf{U}\mathbf{U}^\top = \mathbf{I} \boxtimes \mathbf{I} = \mathbb{I}. \quad (3.7)$$

The orthogonal conjugators have also some properties in relation with projectors:

Theorem 17. : \mathbb{S}^{sph} is unaffected by any orthogonal conjugator, while \mathbb{D}^{dev} commutes with any orthogonal conjugator.

Proof. For any $\mathbf{L} \in \text{Sym}(\mathcal{V})$ and $\mathbf{U} \in \text{Orth}(\mathcal{V})$,

$$\begin{aligned} \mathbb{U}\mathbb{S}^{sph}\mathbf{L} &= (\mathbf{U} \boxtimes \mathbf{U}) \left(\frac{1}{3}\mathbf{I} \otimes \mathbf{I} \right) \mathbf{L} = \frac{1}{3}(\text{tr}\mathbf{L})(\mathbf{U} \boxtimes \mathbf{U})\mathbf{I} = \frac{1}{3}(\text{tr}\mathbf{L})\mathbf{U}\mathbf{I}\mathbf{U}^\top \\ &= \frac{1}{3}(\text{tr}\mathbf{L})\mathbf{I} = \frac{1}{3}\mathbf{I} \cdot \mathbf{L}\mathbf{I} = \frac{1}{3}(\mathbf{I} \otimes \mathbf{I})\mathbf{L} = \mathbb{S}^{sph}\mathbf{L}. \end{aligned}$$

Moreover,

$$\begin{aligned}\mathbb{S}^{sph}\mathbf{U}\mathbf{L} &= \left(\frac{1}{3}\mathbf{I} \otimes \mathbf{I}\right) (\mathbf{U} \boxtimes \mathbf{U})\mathbf{L} = \frac{1}{3}(\mathbf{I} \otimes \mathbf{I})(\mathbf{U}\mathbf{L}\mathbf{U}^\top) = \frac{1}{3}(\mathbf{I} \cdot \mathbf{U}\mathbf{L}\mathbf{U}^\top)\mathbf{I} \\ &= \frac{1}{3}\text{tr}(\mathbf{U}\mathbf{L}\mathbf{U}^\top)\mathbf{I} = \frac{1}{3}\text{tr}(\mathbf{U}^\top\mathbf{U}\mathbf{L})\mathbf{I} = \frac{1}{3}(\text{tr}\mathbf{L})\mathbf{I} = \frac{1}{3}\mathbf{I} \cdot \mathbf{L}\mathbf{I} = \frac{1}{3}(\mathbf{I} \otimes \mathbf{I})\mathbf{L} = \mathbb{S}^{sph}\mathbf{L}.\end{aligned}$$

Thus, we have proved that

$$\mathbb{S}^{sph}\mathbf{U} = \mathbf{U}\mathbb{S}^{sph} = \mathbb{S}^{sph},$$

i.e. that the spherical projector \mathbb{S}^{sph} is unaffected by any orthogonal conjugator. Further

$$\mathbb{D}^{dev}\mathbf{U}\mathbf{L} = (\mathbb{I}^s - \mathbb{S}^{sph})\mathbf{U}\mathbf{L} = \mathbb{I}^s\mathbf{U}\mathbf{L} - \mathbb{S}^{sph}\mathbf{U}\mathbf{L} = \mathbf{U}\mathbf{L} - \mathbb{S}^{sph}\mathbf{L} = (\mathbf{U} - \mathbb{S}^{sph})\mathbf{L}$$

and

$$\mathbf{U}\mathbb{D}^{dev}\mathbf{L} = \mathbf{U}(\mathbb{I}^s - \mathbb{S}^{sph})\mathbf{L} = \mathbf{U}\mathbb{I}^s\mathbf{L} - \mathbf{U}\mathbb{S}^{sph}\mathbf{L} = \mathbf{U}\mathbf{L} - \mathbb{S}^{sph}\mathbf{L} = (\mathbf{U} - \mathbb{S}^{sph})\mathbf{L},$$

so that

$$\mathbb{D}^{dev}\mathbf{U} = \mathbf{U}\mathbb{D}^{dev}.$$

□

3.7 Rotations and symmetries

We ponder now how to rotate a fourth-rank tensor, i.e., what are the components of

$$\mathbb{L} = L_{ijkl}\mathbf{e}_i \otimes \mathbf{e}_j \otimes \mathbf{e}_k \otimes \mathbf{e}_l$$

in a basis $\mathcal{B}' = \{\mathbf{e}'_1, \mathbf{e}'_2, \mathbf{e}'_3\}$ obtained rotating the basis $\mathcal{B} = \{\mathbf{e}_1, \mathbf{e}_2, \mathbf{e}_3\}$ by the rotation $\mathbb{R} = R_{ij}\mathbf{e}_i \otimes \mathbf{e}_j, \mathbb{R} \in \text{Orth}(\mathcal{V})^+$. The procedure is exactly the same already seen for vectors and second-rank tensors:

$$\begin{aligned}\mathbb{L} &= L_{ijkl}\mathbf{e}_i \otimes \mathbf{e}_j \otimes \mathbf{e}_k \otimes \mathbf{e}_l = L_{ijkl}R_{pi}^\top\mathbf{e}'_p \otimes R_{qj}^\top\mathbf{e}'_q \otimes R_{rk}^\top\mathbf{e}'_r \otimes R_{sl}^\top\mathbf{e}'_s \\ &= R_{pi}^\top R_{qj}^\top R_{rk}^\top R_{sl}^\top L_{ijkl}\mathbf{e}'_p \otimes \mathbf{e}'_q \otimes \mathbf{e}'_r \otimes \mathbf{e}'_s,\end{aligned}$$

i.e.

$$L'_{pqrs} = R_{pi}^\top R_{qj}^\top R_{rk}^\top R_{sl}^\top L_{ijkl}.$$

We see clearly that the components of \mathbb{L} in the basis \mathcal{B}' are a linear combination of those in \mathcal{B} , the coefficients of the linear combination being fourth-powers of the director cosines, the R_{ijs} . The introduction of the orthogonal conjugator¹ of the rotation \mathbf{R} ,

$$\mathbb{R} = \mathbf{R} \boxtimes \mathbf{R},$$

allows to give a compact expression for the rotation of second- and fourth-rank tensors (for completeness we recall also that of a vector \mathbf{w});

$$\begin{aligned}\mathbf{w}' &= \mathbf{R}^\top \mathbf{w}, \\ \mathbf{L}' &= \mathbf{R}^\top \mathbf{L} \mathbf{R} = (\mathbf{R}^\top \boxtimes \mathbf{R}^\top) \mathbf{L} = \mathbb{R}^\top \mathbf{L}, \\ \mathbb{L}' &= (\mathbf{R}^\top \boxtimes \mathbf{R}^\top) \mathbb{L} (\mathbf{R} \boxtimes \mathbf{R}) = \mathbb{R}^\top \mathbb{L} \mathbf{R}.\end{aligned}$$

¹Here the symbol \mathbb{R} indicates the orthogonal conjugator of \mathbf{R} , not the set of real numbers.

The check of the above relations with the orthogonal conjugator \mathbb{R} is left to the reader. It is worth noting that actually these transformations are valid not only for $\mathbf{R} \in Orth(\mathcal{V})^+$, but more generally for any $\mathbf{U} \in Orth(\mathcal{V})$, i.e. also for symmetries.

If by \mathbf{U} we denote the tensor of change of basis under any orthogonal transformation, i.e., if we put $\mathbf{U} = \mathbf{R}^\top$ for the rotations, then the above relations become

$$\begin{aligned}\mathbf{w}' &= \mathbf{U}\mathbf{w}, \\ \mathbf{L}' &= \mathbf{U}\mathbf{L}\mathbf{U}^\top = (\mathbf{U} \boxtimes \mathbf{U})\mathbf{L} = \mathbb{U}\mathbf{L}, \\ \mathbb{L}' &= (\mathbf{U} \boxtimes \mathbf{U})\mathbb{L}(\mathbf{U} \boxtimes \mathbf{U})^\top = \mathbb{U}\mathbb{L}\mathbb{U}^\top.\end{aligned}\tag{3.8}$$

Finally, we say that $\mathbf{L} \in Lin(\mathcal{V})$ or $\mathbb{L} \in \mathbb{L}in(\mathcal{V})$ is *invariant under an orthogonal transformation* \mathbf{U} if

$$\mathbf{U}\mathbf{L}\mathbf{U}^\top = \mathbf{L}, \quad \mathbb{U}\mathbb{L}\mathbb{U}^\top = \mathbb{L};$$

right multiplying both terms by \mathbf{U} or by \mathbb{U} and through eq. (3.7), we get that \mathbf{L} or \mathbb{L} are invariant under $\mathbf{U} \iff$

$$\mathbf{U}\mathbf{L} = \mathbf{L}\mathbf{U}, \quad \mathbb{U}\mathbb{L} = \mathbb{L}\mathbb{U},$$

i.e. $\iff \mathbf{L}$ and \mathbf{U} , or \mathbb{L} and \mathbb{U} commute. This relation allows, e.g., the analysis of material symmetries in elasticity.

If a tensor is invariant under *any* orthogonal transformation, i.e. if the previous equations hold true $\forall \mathbf{U} \in Orth(\mathcal{V})$ then the tensor is said to be *isotropic*. A general result² is that a fourth-rank tensor \mathbb{L} is isotropic \iff exist two scalar functions λ, μ such that

$$\mathbb{L}\mathbf{A} = 2\mu\mathbf{A} + \lambda\text{tr}\mathbf{A} \mathbf{I} \quad \forall \mathbf{A} \in Sym(\mathcal{V}).$$

The reader is addressed to the book of Gurtin (see references) for the proof of this result and for a deeper insight in isotropic functions.

3.8 The Kelvin formalism

As already mentioned, though fourth-rank tensors cannot be organized in and represented by a matrix, a matrix formalism for these operators exists. Such formalism is due to Kelvin³ and it is strictly related to the theory of elasticity, i.e. it concerns the Cauchy's stress tensor $\boldsymbol{\sigma}$, the strain tensor $\boldsymbol{\varepsilon}$ and the elasticity tensor \mathbb{E} . The relation between $\boldsymbol{\sigma}$ and $\boldsymbol{\varepsilon}$ is given by the celebrated (generalized) *Hooke's law*:

$$\boldsymbol{\sigma} = \mathbb{E}\boldsymbol{\varepsilon}.$$

Both $\boldsymbol{\sigma}, \boldsymbol{\varepsilon} \in Sym(\mathcal{V})$ while $\mathbb{E} = \mathbb{E}^\top$ and it has also the minor symmetries, so \mathbb{E} has just 21 independent components⁴. In the Kelvin formalism, the six independent components

²Actually, this is a quite famous result in classical elasticity, the Lamé's equation, defining an isotropic elastic material.

³W. Thomson (Lord Kelvin): *Elements of a mathematical theory of elasticity*. Philos. Trans. R. Soc., 146, 481-498, 1856. Later, Voigt (W. Voigt: *Lehrbuch der Kristallphysik*. B. G. Taubner, Leipzig, 1910) gave another, similar matrix formalism for tensors, more widely known than the Kelvin one, but less effective.

⁴Actually, the Kelvin formalism can be extended without major difficulties also to tensors that do not possess all the symmetries.

of $\boldsymbol{\sigma}$ and $\boldsymbol{\varepsilon}$ are organized into column vectors and renumbered as follows

$$\{\boldsymbol{\sigma}\} = \begin{Bmatrix} \sigma_1 = \sigma_{11} \\ \sigma_2 = \sigma_{22} \\ \sigma_3 = \sigma_{33} \\ \sigma_4 = \sqrt{2}\sigma_{23} \\ \sigma_5 = \sqrt{2}\sigma_{31} \\ \sigma_6 = \sqrt{2}\sigma_{12} \end{Bmatrix}, \quad \{\boldsymbol{\varepsilon}\} = \begin{Bmatrix} \varepsilon_1 = \varepsilon_{11} \\ \varepsilon_2 = \varepsilon_{22} \\ \varepsilon_3 = \varepsilon_{33} \\ \varepsilon_4 = \sqrt{2}\varepsilon_{23} \\ \varepsilon_5 = \sqrt{2}\varepsilon_{31} \\ \varepsilon_6 = \sqrt{2}\varepsilon_{12} \end{Bmatrix}.$$

The elasticity tensor \mathbb{E} is reduced to a 6×6 matrix $[E]$, consequence of the minor symmetries induced by the symmetry of $\boldsymbol{\sigma}$ and $\boldsymbol{\varepsilon}$; this matrix is symmetric because $\mathbb{E} = \mathbb{E}^\top$:

$$[E] = \begin{bmatrix} E_{11} = E_{1111} & E_{12} = E_{1122} & E_{13} = E_{1133} & E_{14} = \sqrt{2}E_{1123} & E_{15} = \sqrt{2}E_{1131} & E_{16} = \sqrt{2}E_{1112} \\ E_{12} = E_{1122} & E_{22} = E_{2222} & E_{23} = E_{2233} & E_{24} = \sqrt{2}E_{2223} & E_{25} = \sqrt{2}E_{2231} & E_{26} = \sqrt{2}E_{2212} \\ E_{13} = E_{1133} & E_{23} = E_{2233} & E_{33} = E_{3333} & E_{34} = \sqrt{2}E_{3323} & E_{35} = \sqrt{2}E_{3331} & E_{36} = \sqrt{2}E_{3312} \\ E_{14} = \sqrt{2}E_{1123} & E_{24} = \sqrt{2}E_{2223} & E_{34} = \sqrt{2}E_{3323} & E_{44} = 2E_{2323} & E_{45} = 2E_{2331} & E_{46} = 2E_{2312} \\ E_{15} = \sqrt{2}E_{1131} & E_{25} = \sqrt{2}E_{2231} & E_{35} = \sqrt{2}E_{3331} & E_{45} = 2E_{2331} & E_{55} = 2E_{3131} & E_{56} = 2E_{3112} \\ E_{16} = \sqrt{2}E_{1112} & E_{26} = \sqrt{2}E_{2212} & E_{36} = \sqrt{2}E_{3312} & E_{46} = 2E_{2312} & E_{56} = 2E_{3112} & E_{66} = 2E_{1212} \end{bmatrix}.$$

In this way, the matrix product

$$\{\boldsymbol{\sigma}\} = [E]\{\boldsymbol{\varepsilon}\} \quad (3.9)$$

is equivalent to the tensor form of the Hooke's law and all the operations can be done by the aid of classical matrix algebra⁵, e.g. the computation of the inverse of \mathbb{E} , the *compliance tensor*.

An important operation is the expression of tensor \mathbb{U} in eq. (3.8) in the Kelvin formalism; some tedious but straightforward passages give the result:

$$[U] = \begin{bmatrix} U_{11}^2 & U_{12}^2 & U_{13}^2 & \sqrt{2}U_{12}U_{13} & \sqrt{2}U_{13}U_{11} & \sqrt{2}U_{11}U_{12} \\ U_{21}^2 & U_{22}^2 & U_{23}^2 & \sqrt{2}U_{22}U_{23} & \sqrt{2}U_{23}U_{21} & \sqrt{2}U_{21}U_{22} \\ U_{31}^2 & U_{32}^2 & U_{33}^2 & \sqrt{2}U_{32}U_{33} & \sqrt{2}U_{33}U_{31} & \sqrt{2}U_{31}U_{32} \\ \sqrt{2}U_{21}U_{31} & \sqrt{2}U_{22}U_{32} & \sqrt{2}U_{23}U_{33} & U_{23}U_{32} + U_{22}U_{33} & U_{33}U_{21} + U_{31}U_{23} & U_{31}U_{22} + U_{32}U_{21} \\ \sqrt{2}U_{31}U_{11} & \sqrt{2}U_{32}U_{12} & \sqrt{2}U_{33}U_{13} & U_{32}U_{13} + U_{33}U_{12} & U_{31}U_{13} + U_{33}U_{11} & U_{31}U_{12} + U_{32}U_{11} \\ \sqrt{2}U_{11}U_{21} & \sqrt{2}U_{12}U_{22} & \sqrt{2}U_{13}U_{23} & U_{12}U_{23} + U_{13}U_{22} & U_{11}U_{23} + U_{13}U_{21} & U_{11}U_{22} + U_{12}U_{21} \end{bmatrix}$$

With some work, it can be checked that

$$[U][U]^\top = [U]^\top[U] = [I],$$

i.e. that $[U]$ is an orthogonal matrix in \mathbb{R}^6 . Of course,

$$[R] = [U]^\top$$

is the matrix that in the Kelvin formalism represents the tensor $\mathbf{R} = \mathbf{U}^\top$. The change of basis for $\boldsymbol{\sigma}$ and $\boldsymbol{\varepsilon}$ are hence done through the relations

$$\{\boldsymbol{\sigma}'\} = [U]\{\boldsymbol{\sigma}\}, \quad \{\boldsymbol{\varepsilon}'\} = [U]\{\boldsymbol{\varepsilon}\},$$

⁵Mehrabadi and Cowin have shown that the Kelvin formalism transforms second- and fourth-rank tensors on \mathbb{R}^3 into vectors and second-rank tensors on \mathbb{R}^6 (M. M. Mehrabadi, S. C. Cowin: *Eigentensors of linear anisotropic elastic materials*. Q. J. Mech. Appl. Math., 43, 15-41, 1990).

which applied to eq. (3.9) give

$$\{\sigma\} = [E]\{\varepsilon\} \rightarrow [U]^\top\{\sigma'\} = [E][U]^\top\{\varepsilon'\} \rightarrow \{\sigma'\} = [U][E][U]^\top\{\varepsilon'\}$$

i.e. in the basis \mathcal{B}'

$$\{\sigma'\} = [E']\{\varepsilon'\},$$

where

$$[E'] = [U][E][U]^\top = [R]^\top[E][R]$$

is the matrix representing \mathbb{E} in \mathcal{B}' in the Kelvin formalism. Though it is possible to give the expression of the components of $[E']$, they are so long that they are omitted here.

3.9 Exercises

1. Prove eq. (3.4).

2. Prove that

$$\mathbf{A} \otimes \mathbf{B}\mathbf{L} = \mathbf{A} \otimes \mathbf{L}^\top \mathbf{B}.$$

3. Prove that

$$(\mathbf{A} \boxtimes \mathbf{B})(\mathbf{C} \boxtimes \mathbf{D}) = \mathbf{A}\mathbf{C} \boxtimes \mathbf{B}\mathbf{D}.$$

4. Prove eq. (3.3) using the result of the previous exercise.

5. Prove that

$$(\mathbf{A} \otimes \mathbf{B})(\mathbf{C} \boxtimes \mathbf{D}) = \mathbf{A} \otimes ((\mathbf{C}^\top \boxtimes \mathbf{D}^\top)\mathbf{B}).$$

6. Prove that

$$(\mathbf{A} \boxtimes \mathbf{B})(\mathbf{C} \otimes \mathbf{D}) = ((\mathbf{A} \boxtimes \mathbf{B})\mathbf{C}) \otimes \mathbf{D}.$$

7. Let $\mathbf{p} \in \mathcal{S}$ and $\mathbf{P} = \mathbf{p} \otimes \mathbf{p}$; then prove that

$$\mathbf{P} \boxtimes \mathbf{P} = \mathbf{P} \otimes \mathbf{P}.$$

8. Prove that, $\forall \mathbf{A} \in \text{Lin}(\mathcal{V})$,

$$\mathbb{I}\mathbf{A} = \mathbf{A}\mathbb{I} = \mathbf{A}.$$

9. Show that

$$(\mathbf{A} \otimes \mathbf{B}) \cdot (\mathbf{C} \otimes \mathbf{D}) = \mathbf{A} \cdot \mathbf{C} \mathbf{B} \cdot \mathbf{D}.$$

10. Show that

$$\mathbb{S}^{sph} = \frac{\mathbf{I}}{|\mathbf{I}|} \otimes \frac{\mathbf{I}}{|\mathbf{I}|}.$$

11. Show that

$$\dim(\text{Sph}(\mathcal{V})) = 1, \quad \dim(\text{Dev}(\mathcal{V})) = 5.$$

12. Show the following properties of \mathbb{S}^{sph} and \mathbb{D}^{dev} :

$$\begin{aligned}\mathbb{S}^{sph}\mathbb{S}^{sph} &= \mathbb{S}^{sph}, \\ \mathbb{D}^{dev}\mathbb{D}^{dev} &= \mathbb{D}^{dev}, \\ \mathbb{S}^{sph}\mathbb{D}^{dev} &= \mathbb{D}^{dev}\mathbb{S}^{sph} = \mathbb{O}.\end{aligned}$$

13. Prove the results in eqs. (3.5) and (3.6) using the components.

14. Show that

$$\begin{aligned}\mathbb{S}^{sph} \cdot \mathbb{S}^{sph} &= 1, \\ \mathbb{D}^{dev} \cdot \mathbb{D}^{dev} &= 5, \\ \mathbb{S}^{sph} \cdot \mathbb{D}^{dev} &= 0.\end{aligned}$$

15. Explicit the orthogonal conjugator \mathbb{S}_R of the tensor \mathbf{S}_R in eq. (2.43).

Chapter 4

Tensor analysis: curves

4.1 Curves of points, vectors and tensors

The scalar products in \mathcal{V} , $Lin(\mathcal{V})$ and $\mathbb{L}in(\mathcal{V})$ allow us to define a *norm*, the *Euclidean norm*, so they automatically endow these spaces with a *metric*, i.e. we are able to measure and calculate a distance between two elements of such a space and in \mathcal{E} . This allows us to generalise the concepts of continuity and differentiability already known in \mathbb{R} , whose definition intrinsically makes use of a distance between real quantities.

Let $\pi_n = \{p_n \in \mathcal{E}, n \in \mathbb{N}\}$ a sequence of points in \mathcal{E} . We say that π_n *converges to* $p \in \mathcal{E}$ if

$$\lim_{n \rightarrow \infty} d(p_n - p) = 0.$$

A similar definition can be given for sequences of vectors or tensors of any rank. Through this definition of convergence we can now precise the concepts of continuity and of curve.

Let $[a, b]$ an interval of \mathbb{R} ; the function

$$p = p(t) : [a, b] \rightarrow \mathcal{E}$$

is *continuous* at $t \in [a, b]$ if for each sequence $\{t_n \in [a, b], n \in \mathbb{N}\}$ that converges to t the sequence π_n defined by $p_n = p(t_n) \forall n \in \mathbb{N}$ converges to $p(t) \in \mathcal{E}$. The function $p = p(t)$ is a *curve in* $\mathcal{E} \iff$ it is continuous $\forall t \in [a, b]$. In the same way we can define a curve of vectors and of tensors:

$$\begin{aligned} \mathbf{v} &= \mathbf{v}(t) : [a, b] \rightarrow \mathcal{V}, \\ \mathbf{L} &= \mathbf{L}(t) : [a, b] \rightarrow Lin(\mathcal{V}), \\ \mathbb{L} &= \mathbb{L}(t) : [a, b] \rightarrow \mathbb{L}in(\mathcal{V}). \end{aligned}$$

Mathematically, a curve is a function that lets correspond to a real value t (the *parameter*) in an interval an element of a space, \mathcal{E} , \mathcal{V} , $Lin(\mathcal{V})$ or $\mathbb{L}in(\mathcal{V})$.

4.2 Differentiation of curves

Let $\mathbf{v} = \mathbf{v}(t) : [a, b] \rightarrow \mathcal{V}$ a curve of vectors and $g = g(t) : [a, b] \rightarrow \mathbb{R}$ a scalar function. We say that \mathbf{v} is *of the order o with respect to g in t_0* \iff

$$\lim_{t \rightarrow t_0} \frac{|\mathbf{v}(t)|}{|g(t)|} = 0,$$

and we write

$$\mathbf{v}(t) = o(g(t)) \text{ for } t \rightarrow t_0.$$

A similar definition can be given for a curve of tensors of any rank. We then say that the curve \mathbf{v} is *differentiable* in $t_0 \in]a, b[\iff \exists \mathbf{v}' \in \mathcal{V}$ such that

$$\mathbf{v}(t) - \mathbf{v}(t_0) = (t - t_0)\mathbf{v}' + o(t - t_0).$$

We call \mathbf{v}' the *derivative of \mathbf{v}^1* , also indicated by $\frac{d\mathbf{v}}{dt}$. Applying the definition of derivative to \mathbf{v}' we define the *second derivative \mathbf{v}''* of \mathbf{v} and recursively all the derivatives of higher orders. We say that \mathbf{v} is of *class C^n* if it is continuous with its derivatives up to the order n ; if $n \geq 1$, \mathbf{v} is said to be *smooth*. A curve $\mathbf{v}(t)$ of class C^n is said to be *regular* if $\mathbf{v}' \neq \mathbf{o} \forall t$. Similar definitions can be given for curves in \mathcal{E} , $Lin(\mathcal{V})$ and $\mathbb{L}in(\mathcal{V})$, so defining derivatives of points and tensors. We remark that the derivative of a curve in \mathcal{E} , defined as a difference of points, is a curve in \mathcal{V} (we say, in short, that *the derivative of a point is a vector*). For what concerns tensors, the derivative of a tensor of rank r is a tensor of the same rank.

Let \mathbf{u}, \mathbf{v} curves in \mathcal{V} , \mathbf{L}, \mathbf{M} curves in $Lin(\mathcal{V})$, \mathbb{L}, \mathbb{M} curves in $\mathbb{L}in(\mathcal{V})$ and α a scalar function, all of them defined and at least of class C^1 on $[a, b]$. The same definition of derivative of a curve gives the following results, whose proof is left to the reader:

$$\begin{aligned} (\mathbf{u} + \mathbf{v})' &= \mathbf{u}' + \mathbf{v}', \\ (\alpha\mathbf{v})' &= \alpha'\mathbf{v} + \alpha\mathbf{v}', \\ (\mathbf{u} \cdot \mathbf{v})' &= \mathbf{u}' \cdot \mathbf{v} + \mathbf{u} \cdot \mathbf{v}', \\ (\mathbf{u} \times \mathbf{v})' &= \mathbf{u}' \times \mathbf{v} + \mathbf{u} \times \mathbf{v}', \\ (\mathbf{u} \otimes \mathbf{v})' &= \mathbf{u}' \otimes \mathbf{v} + \mathbf{u} \otimes \mathbf{v}', \\ (\mathbf{L} + \mathbf{M})' &= \mathbf{L}' + \mathbf{M}', \\ (\alpha\mathbf{L})' &= \alpha'\mathbf{L} + \alpha\mathbf{L}', \\ (\mathbf{L}\mathbf{v})' &= \mathbf{L}'\mathbf{v} + \mathbf{L}\mathbf{v}', \\ (\mathbf{L}\mathbf{M})' &= \mathbf{L}'\mathbf{M} + \mathbf{L}\mathbf{M}', \\ (\mathbf{L} \cdot \mathbf{M})' &= \mathbf{L}' \cdot \mathbf{M} + \mathbf{L} \cdot \mathbf{M}', \end{aligned}$$

¹The symbol \cdot is also used, but it is usually reserved, in physics, to the case where t is the time.

$$\begin{aligned}
(\mathbf{L} \otimes \mathbf{M})' &= \mathbf{L}' \otimes \mathbf{M} + \mathbf{L} \otimes \mathbf{M}', \\
(\mathbf{L} \boxtimes \mathbf{M})' &= \mathbf{L}' \boxtimes \mathbf{M} + \mathbf{L} \boxtimes \mathbf{M}', \\
(\mathbf{L} + \mathbf{M})' &= \mathbf{L}' + \mathbf{M}', \\
(\alpha \mathbf{L})' &= \alpha' \mathbf{L} + \alpha \mathbf{L}', \\
(\mathbf{L} \mathbf{L})' &= \mathbf{L}' \mathbf{L} + \mathbf{L} \mathbf{L}', \\
(\mathbf{L} \mathbf{M})' &= \mathbf{L}' \mathbf{M} + \mathbf{L} \mathbf{M}', \\
(\mathbf{L} \cdot \mathbf{M})' &= \mathbf{L}' \cdot \mathbf{M} + \mathbf{L} \cdot \mathbf{M}'.
\end{aligned}$$

To remark that the derivative of any kind of product is made according to the usual rule of the derivative of a product of functions.

Be $\mathcal{R} = \{o; \mathcal{B}\}$ a reference frame of the euclidean space \mathcal{E} , composed by an *origin* o and a basis $\mathcal{B} = \{\mathbf{e}_1, \mathbf{e}_2, \mathbf{e}_3\}$ of \mathcal{V} , $\mathbf{e}_i \cdot \mathbf{e}_j = \delta_{ij} \forall i, j = 1, 2, 3$ and let us consider a point $p(t) = (p_1(t), p_2(t), p_3(t))$. If the three *coordinates* $p_i(t)$ are three continuous functions over the interval $[t_1, t_2] \in \mathbb{R}$, then, by the definition given above, the mapping $p(t) : [t_1, t_2] \rightarrow \mathcal{E}$ is a curve in \mathcal{E} and the equation

$$p(t) = (p_1(t), p_2(t), p_3(t)) \rightarrow \begin{cases} p_1 = p_1(t) \\ p_2 = p_2(t) \\ p_3 = p_3(t) \end{cases}$$

is the *parametric point equation of the curve*: to each value of $t \in [t_1, t_2]$ it corresponds a point of the curve in \mathcal{E} , see Fig. 4.1.

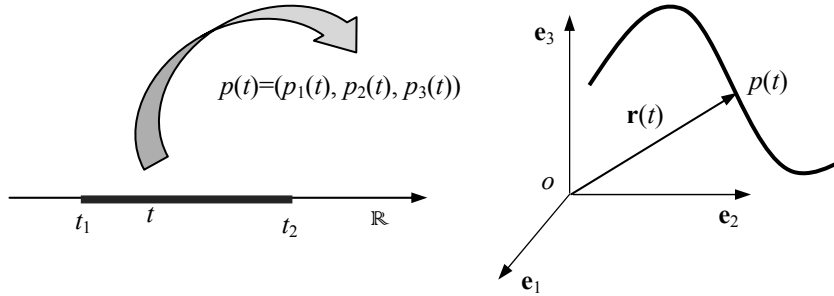

Figure 4.1: Mapping of a curve of points.

The vector function $\mathbf{r}(t) = p(t) - o$ is the *position vector* of point p in \mathcal{R} ; the equation

$$\mathbf{r}(t) = r_i(t) \mathbf{e}_i = r_1(t) \mathbf{e}_1 + r_2(t) \mathbf{e}_2 + r_3(t) \mathbf{e}_3 \rightarrow \begin{cases} r_1 = r_1(t) \\ r_2 = r_2(t) \\ r_3 = r_3(t) \end{cases}$$

is the *parametric vector equation* of the curve: to each value of $t \in [t_1, t_2]$ it corresponds a vector of \mathcal{V} that determines a point of the curve in \mathcal{E} through the operation $p(t) = o + \mathbf{r}(t)$.

Similarly, if the components $L_{ij}(t)$ are continuous functions of a parameter t , the mapping $\mathbf{L}(t) : [t_1, t_2] \rightarrow \text{Lin}(\mathcal{V})$ defined by

$$\mathbf{L}(t) = L_{ij}(t)\mathbf{e}_i \otimes \mathbf{e}_j, \quad i, j = 1, 2, 3,$$

is a curve of tensors. In the same way we can give a curve of fourth-rank tensors $\mathbb{L}(t) : [t_1, t_2] \rightarrow \mathbb{L}\text{in}(\mathcal{V})$ by

$$\mathbb{L}(t) = L_{ijkl}(t)\mathbf{e}_i \otimes \mathbf{e}_j \otimes \mathbf{e}_k \otimes \mathbf{e}_l, \quad i, j, k, l = 1, 2, 3.$$

To be noticed that the choice of the parameter is *not unique*: the equation $p = p[\tau(t)]$ still represents the same curve $p = p(t)$, through the *change of parameter* $\tau = \tau(t)$.

The definition given above for the derivative of a curve of points $p = p(t)$ in $t = t_0$ is equivalent to the following one (probably more familiar to the reader)

$$\frac{dp(t)}{dt} = \lim_{\varepsilon \rightarrow 0} \frac{p(t_0 + \varepsilon) - p(t_0)}{\varepsilon};$$

represented in Fig. 4.2, it is apparent that $\mathbf{r}'(t) = \frac{dp(t)}{dt}$ is a vector.

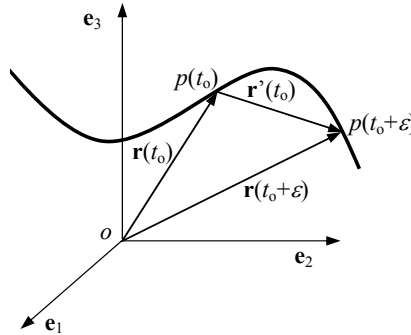

Figure 4.2: Derivative of a curve.

An important case is that of a vector $\mathbf{v}(t)$ whose norm $v(t)$ is constant $\forall t$:

$$(v^2)' = (\mathbf{v} \cdot \mathbf{v})' = \mathbf{v}' \cdot \mathbf{v} + \mathbf{v} \cdot \mathbf{v}' = 2\mathbf{v}' \cdot \mathbf{v} = 0 : \quad (4.1)$$

the derivative of such a vector is orthogonal to it $\forall t$. The contrary is also true, as immediately apparent.

Finally, using the above rules and assuming that the reference frame \mathcal{R} is independent from t , we get easily that

$$\begin{aligned} p'(t) &= p'_i(t) \mathbf{e}_i, \\ \mathbf{v}'(t) &= v'_i(t) \mathbf{e}_i, \\ \mathbf{L}'(t) &= L'_{ij}(t) \mathbf{e}_i \otimes \mathbf{e}_j, \\ \mathbb{L}'(t) &= L'_{ijkl}(t) \mathbf{e}_i \otimes \mathbf{e}_j \otimes \mathbf{e}_k \otimes \mathbf{e}_l, \end{aligned} \quad (4.2)$$

i.e. that the derivative of a curve of points, vectors or tensors is simply calculated differentiating the coordinates or the components.

More involved is to prove that

$$\begin{aligned}(\mathbf{L}^\top)' &= \mathbf{L}'^\top, \\(\mathbb{L}^\top)' &= \mathbb{L}'^\top, \\(\det \mathbf{L})' &= \det \mathbf{L} \operatorname{tr}(\mathbf{L}'\mathbf{L}^{-1}) = \det \mathbf{L} \mathbf{L}^{\top'} \cdot \mathbf{L}^{-1} = \det \mathbf{L} \mathbf{L}' \cdot \mathbf{L}^{-\top},\end{aligned}$$

the reader is addressed to the book of Gurtin for the proof.

4.3 Integral of a curve of vectors, length of a curve

We define *integral of a curve of vectors* $\mathbf{r}(t)$ between a and $b \in [t_1, t_2]$ the curve that is obtained integrating each component of the curve:

$$\int_a^b \mathbf{r}(t) dt = \int_a^b r_i(t) dt \mathbf{e}_i.$$

If the curve is regular, we can generalize the second fundamental theorem of the integral calculus

$$\mathbf{r}(t) = \mathbf{r}(a) + \int_a^t \mathbf{r}'(t^*) dt^*.$$

Because

$$\mathbf{r}(t) = p(t) - o, \quad \mathbf{r}'(t) = (p(t) - o)' = p'(t),$$

we get also

$$p(t) = p(a) + \int_a^t p'(t^*) dt^*.$$

The integral of a vector function is the generalization of the vector sum, see Fig. 4.3.

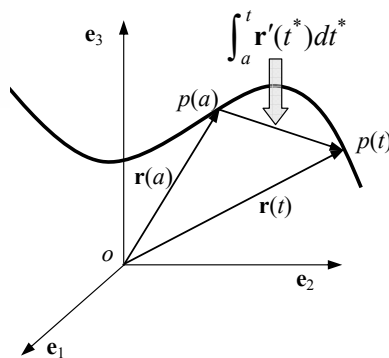

Figure 4.3: Integral of a vector curve.

Be $\mathbf{r}(t) : [a, b] \rightarrow \mathcal{E}$ a regular curve, σ a partition of the type $a = t_0 < t_1 < \dots < t_n = b$, and

$$\sigma_{max} = \max_{i=1, \dots, n} |t_i - t_{i-1}|.$$

The length ℓ_σ of the polygonal line whose vertices are the points $\mathbf{r}(t_i)$ is hence:

$$\ell_\sigma = \sum_{i=1}^n |\mathbf{r}(t_i) - \mathbf{r}(t_{i-1})|.$$

We define *length of the curve* $\mathbf{r}(t)$ the (positive) number

$$\ell := \sup_{\sigma} \ell_\sigma.$$

Theorem 18. *Be $\mathbf{r}(t) : [a, b] \Rightarrow \mathcal{E}$ a regular curve; then*

$$\ell = \int_a^b |\mathbf{r}'(t)| dt.$$

Proof. By the fundamental theorem of calculus,

$$\mathbf{r}(t_i) - \mathbf{r}(t_{i-1}) = \int_{t_{i-1}}^{t_i} \mathbf{r}'(t) dt \rightarrow |\mathbf{r}(t_i) - \mathbf{r}(t_{i-1})| = \left| \int_{t_{i-1}}^{t_i} \mathbf{r}'(t) dt \right| \leq \int_{t_{i-1}}^{t_i} |\mathbf{r}'(t)| dt,$$

whence

$$\ell \leq \int_a^b |\mathbf{r}'(t)| dt. \quad (4.3)$$

Because $\mathbf{r}'(t)$ is continuous on $[a, b]$, $\forall \varepsilon > 0 \exists \delta > 0$ such that $|t - \bar{t}| < \delta \Rightarrow |\mathbf{r}'(t) - \mathbf{r}'(\bar{t})| < \varepsilon$. Be $t \in [t_{i-1}, t_i]$ and $\sigma_{max} < \delta$, which is always possible by the choice of the partition σ ; by the triangular inequality,

$$|\mathbf{r}'(t)| \leq |\mathbf{r}'(t) - \mathbf{r}'(t_i)| + |\mathbf{r}'(t_i)| < \varepsilon + |\mathbf{r}'(t_i)|,$$

whence

$$\begin{aligned} \int_{t_{i-1}}^{t_i} |\mathbf{r}'(t)| dt &< \int_{t_{i-1}}^{t_i} |\mathbf{r}'(t_i)| dt + \varepsilon(t_i - t_{i-1}) = \left| \int_{t_{i-1}}^{t_i} \mathbf{r}'(t_i) dt \right| + \varepsilon(t_i - t_{i-1}) \\ &\leq \left| \int_{t_{i-1}}^{t_i} \mathbf{r}'(t) dt \right| + \left| \int_{t_{i-1}}^{t_i} (\mathbf{r}'(t_i) - \mathbf{r}'(t)) dt \right| + \varepsilon(t_i - t_{i-1}) \\ &\leq |\mathbf{r}(t_i) - \mathbf{r}(t_{i-1})| + 2\varepsilon(t_i - t_{i-1}). \end{aligned}$$

Summing up over all the intervals $[t_{i-1}, t_i]$ we get

$$\int_a^b |\mathbf{r}'(t)| dt \leq \ell_\sigma + 2\varepsilon(b - a) \leq \ell + 2\varepsilon(b - a),$$

and because ε is arbitrary,

$$\int_a^b |\mathbf{r}'(t)| dt \leq \ell,$$

which by eq. (4.3) implies the thesis. □

Theorem 19. *The length of a curve does not depend upon its parameterization.*

Proof. Be $\mathbf{r}(t) : [a, b] \rightarrow \mathcal{E}$ a regular curve and $t = t(\tau) : [c, d] \rightarrow [a, b]$ a change of parameter; then

$$\ell = \int_a^b |\mathbf{r}'(t)| dt = \int_c^d |\mathbf{r}'(t(\tau))t'(\tau)| d\tau = \int_c^d |\mathbf{r}'(\tau)| d\tau.$$

□

A simple way to determine a point $p(t)$ on a curve is to fix a point p_0 on the curve and to measure the length $s(t)$ of the arc of curve between $p_0 = p(t = 0)$ and $p(t)$. This length $s(t)$ is called *curvilinear abscissa*²:

$$s(t) = \int_0^t |\mathbf{r}'(t^*)| dt^* = \int_0^t |(p(t^*) - o)'| dt^*. \quad (4.4)$$

From eq. (4.4) we get

$$\frac{ds}{dt} = |\mathbf{r}'(t)| > 0,$$

so that $s(t)$ is an increasing function of t and the length of an infinitesimal arc is

$$ds = \sqrt{dr_1^2 + dr_2^2 + dr_3^2}.$$

For a plane curve $y = f(x)$, we can always put $t = x$, which gives the parametric equation

$$p(t) = (t, f(t)),$$

or in vector form

$$\mathbf{r}(t) = t \mathbf{e}_1 + f(t) \mathbf{e}_2,$$

from which we obtain

$$\frac{ds}{dt} = |\mathbf{r}'(t)| = |p'(t)| = \sqrt{1 + f'^2(t)}, \quad (4.5)$$

that gives the length of a plane curve between $t = x_0$ and $t = x$ as a function of the abscissa x :

$$s(x) = \int_{x_0}^x \sqrt{1 + f'^2(t)} dt.$$

²The curvilinear abscissa is also called *arc-length* or *natural parameter*.

4.4 The Frenet-Serret basis

We define the *tangent vector* $\boldsymbol{\tau}(t)$ to a regular curve $p = p(t)$ the vector

$$\boldsymbol{\tau}(t) = \frac{p'(t)}{|p'(t)|}.$$

By the definition of derivative, this unit vector is always oriented as the increasing values of t ; the straight line tangent to the curve in $p_0 = p(t_0)$ has hence equation

$$q(\bar{t}) = p(t_0) + \bar{t} \boldsymbol{\tau}(t_0).$$

If the curvilinear abscissa s is chosen as parameter for the curve, through the change of parameter $s = s(t)$ we get

$$\boldsymbol{\tau}(t) = \frac{p'(t)}{|p'(t)|} = \frac{p'[s(t)]}{|p'[s(t)]|} = \frac{1}{s'(t)} \frac{dp(s)}{ds} \frac{ds(t)}{dt} = \frac{dp(s)}{ds} \rightarrow \boldsymbol{\tau}(s) = p'(s).$$

So, if the parameter of the curve is s , the derivative of the curve is $\boldsymbol{\tau}$, i.e. it is automatically a unit vector. The above equation, in addition, shows that the change of parameter does not change the direction of the tangent, because just a scalar, the derivative of the parameter's change, multiplies the vector. Nevertheless, generally speaking, a change of parameter can change the orientation of the curve.

Because the norm of $\boldsymbol{\tau}$ is constant, its derivative is a vector orthogonal to $\boldsymbol{\tau}$, see eq. (4.1). That is why we call *principal normal vector* to a curve the unit vector

$$\boldsymbol{\nu}(t) = \frac{\boldsymbol{\tau}'(t)}{|\boldsymbol{\tau}'(t)|}. \quad (4.6)$$

$\boldsymbol{\nu}$ is defined only on the points of the curve where $\boldsymbol{\tau}' \neq \mathbf{0}$ which implies that $\boldsymbol{\nu}$ is not defined on the points of a straight line. This simply means that there is not, among the infinite unit normal vectors to a straight line, a normal with special properties, a *principal* one, uniquely linked to $\boldsymbol{\tau}$.

Unlike $\boldsymbol{\tau}$, whose orientation changes with the choice of the parameter, $\boldsymbol{\nu}$ is an *intrinsic* local characteristic of the curve: *it is not affected by the choice of the parameter*. In fact, by its same definition, $\boldsymbol{\nu}$ does not depend upon the reference frame; then, because the direction of $\boldsymbol{\tau}$ is also independent upon the parameter's choice, the only factor that could affect $\boldsymbol{\nu}$ is the orientation of the curve, that depends upon the parameter. But a change of the orientation affects, in (4.6), both $\boldsymbol{\tau}$ and the sign of the increment dt , so that $\boldsymbol{\tau}'(t) = d\boldsymbol{\tau}/dt$ does not change, neither $\boldsymbol{\nu}$, which is hence an intrinsic property of the curve.

The vector

$$\boldsymbol{\beta}(t) = \boldsymbol{\tau}(t) \times \boldsymbol{\nu}(t)$$

is called the *binormal vector*; by construction, it is orthogonal to $\boldsymbol{\tau}$ and $\boldsymbol{\nu}$ and it is a unit vector. In addition, it is evident that

$$\boldsymbol{\tau} \times \boldsymbol{\nu} \cdot \boldsymbol{\beta} = 1,$$

so the set $\{\boldsymbol{\tau}, \boldsymbol{\nu}, \boldsymbol{\beta}\}$ forms a positively oriented orthonormal basis that can be defined at any regular point of a curve with $\boldsymbol{\tau}' \neq \mathbf{o}$. Such a basis is called the *Frenet-Serret local basis*, local in the sense that it changes with the position along the curve. The plane $\boldsymbol{\tau} - \boldsymbol{\nu}$ is the *osculating plane*, the plane $\boldsymbol{\nu} - \boldsymbol{\beta}$ the *normal plane* and the plane $\boldsymbol{\beta} - \boldsymbol{\tau}$ the *rectifying plane*, see Fig. 4.4. The osculating plane is particularly important: if we

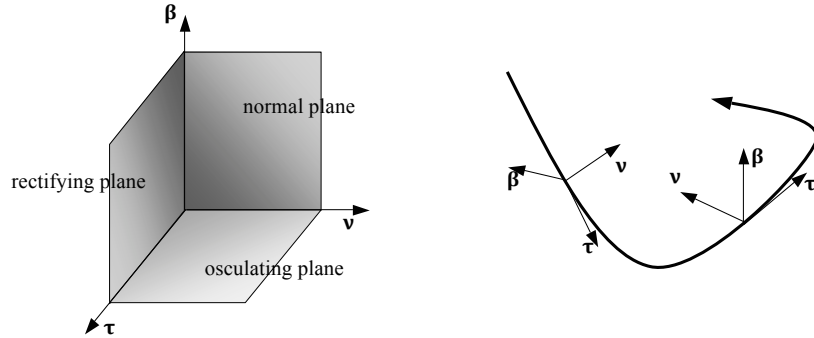

Figure 4.4: The Frenet-Serret basis.

consider a plane passing through three not aligned points of the curve, when these points become closer and closer, still remaining on the curve, the plane tends to the osculating plane: the osculating plane at a point of a curve is the plane that better approaches the curve near the point. A plane curve is entirely contained in the osculating plane, which is fixed.

The principal normal $\boldsymbol{\nu}$ is always oriented towards the part of the space, with respect to the rectifying plane, where the curve is; in particular, for a plane curve, $\boldsymbol{\nu}$ is always directed towards the concavity of the curve. To show it, it is sufficient to prove that the vector $p(t + \varepsilon) - p(t)$ forms with $\boldsymbol{\nu}$ an angle $\psi \leq \pi/2$, i.e. that $(p(t + \varepsilon) - p(t)) \cdot \boldsymbol{\nu} \geq 0$. In fact,

$$p(t + \varepsilon) - p(t) = \varepsilon p'(t) + \frac{1}{2}\varepsilon^2 p''(t) + o(\varepsilon^2) \rightarrow$$

$$(p(t + \varepsilon) - p(t)) \cdot \boldsymbol{\nu} = \frac{1}{2}\varepsilon^2 p''(t) \cdot \boldsymbol{\nu} + o(\varepsilon^2),$$

but

$$p''(t) \cdot \boldsymbol{\nu} = (\boldsymbol{\tau}'|p'| + \boldsymbol{\tau}|p'|') \cdot \boldsymbol{\nu} = (|\boldsymbol{\tau}'||p'| \boldsymbol{\nu} + \boldsymbol{\tau}|p'|') \cdot \boldsymbol{\nu} = |\boldsymbol{\tau}'||p'|,$$

so that, to within infinitesimal quantities of order $o(\varepsilon^2)$, we obtain

$$(p(t + \varepsilon) - p(t)) \cdot \boldsymbol{\nu} = \frac{1}{2}\varepsilon^2 |\boldsymbol{\tau}'||p'| \geq 0.$$

4.5 Curvature of a curve

It is important, in several situations, to evaluate how much a curve moves away from a straight line, in the neighborhood of a point. To do that, we calculate the angle formed by the tangents at two close points, determined by the curvilinear abscissae s and $s + \varepsilon$, and we measure the angle $\chi(s, \varepsilon)$ that they form, see Fig. 4.5.

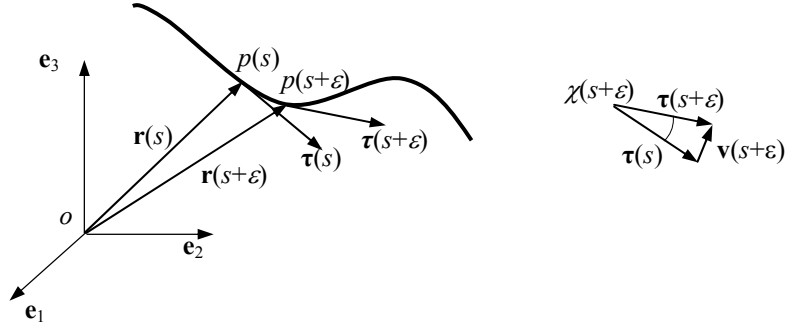

Figure 4.5: Curvature of a curve.

We then define *curvature* of the curve in $p = p(s)$ the limit

$$c(s) = \lim_{\varepsilon \rightarrow 0} \left| \frac{\chi(s, \varepsilon)}{\varepsilon} \right|.$$

The curvature is hence a non-negative scalar that measures the rapidity of variation of the direction of the curve per unit length of the curve (that is why $c(s)$ is defined as a function of the curvilinear abscissa); by its same definition, the curvature is an *intrinsic property* of the curve, i.e. independent from the parameter's choice. For a straight line, the curvature is identically null everywhere.

The curvature is linked to the second derivative of the curve:

$$\begin{aligned} c(s) &= \lim_{\varepsilon \rightarrow 0} \left| \frac{\chi(s, \varepsilon)}{\varepsilon} \right| = \lim_{\varepsilon \rightarrow 0} \left| \frac{\sin \chi(s, \varepsilon)}{\varepsilon} \right| = \lim_{\varepsilon \rightarrow 0} \left| \frac{2}{\varepsilon} \sin \frac{\chi(s, \varepsilon)}{2} \right| = \\ &= \lim_{\varepsilon \rightarrow 0} \left| \frac{\mathbf{v}(s, \varepsilon)}{\varepsilon} \right| = \lim_{\varepsilon \rightarrow 0} \left| \frac{\boldsymbol{\tau}(s + \varepsilon) - \boldsymbol{\tau}(s)}{\varepsilon} \right| = |\boldsymbol{\tau}'(s)| = |p''(s)|. \end{aligned}$$

Another formula for the calculation of $c(s)$ can be obtained if we consider that

$$\frac{d\boldsymbol{\tau}[s(t)]}{dt} = \frac{d\boldsymbol{\tau}}{ds} \frac{ds}{dt} = \frac{d\boldsymbol{\tau}}{ds} |p'(t)| \rightarrow \frac{d\boldsymbol{\tau}}{ds} = \frac{1}{|p'(t)|} \frac{d\boldsymbol{\tau}}{dt},$$

so that

$$c(s) = |\boldsymbol{\tau}'(s)| = \frac{1}{|p'(t)|} \left| \frac{d\boldsymbol{\tau}}{dt} \right| = \frac{|\boldsymbol{\tau}'(t)|}{|p'(t)|}. \quad (4.7)$$

A better formula can be obtained as follows:

$$\begin{aligned} \frac{d\boldsymbol{\tau}}{ds} &= \frac{1}{|p'(t)|} \frac{d\boldsymbol{\tau}}{dt} = \frac{1}{|p'(t)|} \frac{d}{dt} \frac{p'(t)}{|p'(t)|} = \frac{1}{|p'|} \frac{p''|p'| - p' \frac{p'' \cdot p'}{|p'|}}{|p'|^2} = \\ &= \frac{p'' - \boldsymbol{\tau} p'' \cdot \boldsymbol{\tau}}{|p'|^2} = (\mathbf{I} - \boldsymbol{\tau} \otimes \boldsymbol{\tau}) \frac{p''}{|p'|^2}. \end{aligned}$$

By consequence,

$$c(s) = \left| \frac{d\boldsymbol{\tau}(s)}{ds} \right| = \frac{1}{|p'|^2} |(\mathbf{I} - \boldsymbol{\tau} \otimes \boldsymbol{\tau})p''|.$$

Now, we use the following general formula expressing a skew tensor \mathbf{W} :

$$\mathbf{W}\mathbf{W} = -\frac{1}{2}|\mathbf{W}|^2(\mathbf{I} - \mathbf{w} \otimes \mathbf{w});$$

if we use this formula for $\boldsymbol{\tau}$, so that \mathbf{W} is the axial tensor of $\boldsymbol{\tau}$, we get

$$\mathbf{I} - \boldsymbol{\tau} \otimes \boldsymbol{\tau} = -2 \frac{\mathbf{W}\mathbf{W}}{|\mathbf{W}|^2} = -\mathbf{W}\mathbf{W},$$

because if $\boldsymbol{\tau} = (\tau_1, \tau_2, \tau_3)$, then

$$\begin{aligned} |\mathbf{W}|^2 = \mathbf{W} \cdot \mathbf{W} &= \begin{bmatrix} 0 & -\tau_3 & \tau_2 \\ \tau_3 & 0 & -\tau_1 \\ -\tau_2 & \tau_1 & 0 \end{bmatrix} \cdot \begin{bmatrix} 0 & -\tau_3 & \tau_2 \\ \tau_3 & 0 & -\tau_1 \\ -\tau_2 & \tau_1 & 0 \end{bmatrix} = \\ &2(\tau_1^2 + \tau_2^2 + \tau_3^2) = 2. \end{aligned}$$

So, recalling that for any skew tensor \mathbf{W} ,

$$\mathbf{W} \mathbf{u} = \mathbf{w} \times \mathbf{u} \quad \forall \mathbf{u} \in \mathcal{V},$$

with \mathbf{w} the axial vector of \mathbf{W} , we get

$$\begin{aligned} |(\mathbf{I} - \boldsymbol{\tau} \otimes \boldsymbol{\tau})p''| &= |-\mathbf{W}\mathbf{W}p''| = |-\mathbf{W}(\boldsymbol{\tau} \times p'')| = |-\boldsymbol{\tau} \times (\boldsymbol{\tau} \times p'')| = \\ &|\boldsymbol{\tau} \times (\boldsymbol{\tau} \times p'')| = |\boldsymbol{\tau} \times p''| = \frac{|p' \times p''|}{|p'|}, \end{aligned}$$

so that finally

$$c = \frac{|p' \times p''|}{|p'|^3}. \quad (4.8)$$

Applying this last formula to a plane curve $p(t) = (x(t), y(t))$, we get

$$c = \frac{|x'y'' - x''y'|}{(x'^2 + y'^2)^{\frac{3}{2}}}$$

and if the curve is given in the form $y = y(x)$, so that the parameter $t = x$, then we obtain

$$c = \frac{|y''|}{(1 + y'^2)^{\frac{3}{2}}}.$$

This last formula shows that if $|y'| \ll 1$, like in the infinitesimal theory of strain, then

$$c \simeq |y''|.$$

4.6 The Frenet-Serret formulae

From eqs. (4.6) for $t = s$ and (4.7) we get

$$\frac{d\boldsymbol{\tau}}{ds} = c \boldsymbol{\nu} \quad (4.9)$$

which is the *first Frenet-Serret Formula*, giving the variation of $\boldsymbol{\tau}$ per unit length of the curve. Such a variation is a vector whose norm is the curvature and that has as direction that of $\boldsymbol{\nu}$.

Let us now consider the variation of $\boldsymbol{\beta}$ per unit length of the curve; because $\boldsymbol{\beta}$ is a unit vector, we have

$$\frac{d\boldsymbol{\beta}}{ds} \cdot \boldsymbol{\beta} = 0,$$

and

$$\boldsymbol{\beta} \cdot \boldsymbol{\tau} = 0 \Rightarrow \frac{d(\boldsymbol{\beta} \cdot \boldsymbol{\tau})}{ds} = \frac{d\boldsymbol{\beta}}{ds} \cdot \boldsymbol{\tau} + \boldsymbol{\beta} \cdot \frac{d\boldsymbol{\tau}}{ds} = 0.$$

Through eq. (4.9) and because $\boldsymbol{\beta} \cdot \boldsymbol{\nu} = 0$ we get

$$\frac{d\boldsymbol{\beta}}{ds} \cdot \boldsymbol{\tau} = -c \boldsymbol{\beta} \cdot \boldsymbol{\nu} = 0,$$

so that $\frac{d\boldsymbol{\beta}}{ds}$ is necessarily parallel to $\boldsymbol{\nu}$. We then put

$$\frac{d\boldsymbol{\beta}}{ds} = \vartheta \boldsymbol{\nu},$$

which is the *second Frenet-Serret formula*. The scalar $\vartheta(s)$ is called the *torsion of the curve* in $p = p(s)$. So, we see that the variation of $\boldsymbol{\beta}$ per unit length is a vector parallel to $\boldsymbol{\nu}$ and proportional to the torsion of the curve.

We can now find the variation of $\boldsymbol{\nu}$ per unit length of the curve:

$$\frac{d\boldsymbol{\nu}}{ds} = \frac{d(\boldsymbol{\beta} \times \boldsymbol{\tau})}{ds} = \frac{d\boldsymbol{\beta}}{ds} \times \boldsymbol{\tau} + \boldsymbol{\beta} \times \frac{d\boldsymbol{\tau}}{ds} = \vartheta \boldsymbol{\nu} \times \boldsymbol{\tau} + c \boldsymbol{\beta} \times \boldsymbol{\nu},$$

so finally

$$\frac{d\boldsymbol{\nu}}{ds} = -c \boldsymbol{\tau} - \vartheta \boldsymbol{\beta},$$

which is the *third Frenet-Serret formula*: the variation of $\boldsymbol{\nu}$ per unit length of the curve is a vector of the rectifying plane.

The three formulae of Frenet-Serret (discovered independently by J. F. Frenet in 1847 and by J. A. Serret in 1851) can be condensed in the symbolic matrix product

$$\begin{Bmatrix} \boldsymbol{\tau}' \\ \boldsymbol{\nu}' \\ \boldsymbol{\beta}' \end{Bmatrix} = \begin{bmatrix} 0 & c & 0 \\ -c & 0 & -\vartheta \\ 0 & \vartheta & 0 \end{bmatrix} \begin{Bmatrix} \boldsymbol{\tau} \\ \boldsymbol{\nu} \\ \boldsymbol{\beta} \end{Bmatrix}.$$

The matrix in the equation above is called the *matrix of Cartan*, and it is skew.

4.7 The torsion of a curve

We have introduced the torsion of a curve in the previous section, with the second formula of Frenet-Serret. The torsion measures the deviation of a curve from flatness: if a curve is planar, it belongs to the osculating plane and β , which is perpendicular to the osculating plane, is hence a constant vector. So, its derivative is null and by the Frenet-Serret second formula $\vartheta = 0$.

Conversely, if $\vartheta = 0$ everywhere, β is a constant vector and hence the osculating plane does not change and the curve is planar. So we have that *a curve is planar if and only if the torsion is null $\forall p(s)$.*

Using the Frenet-Serret formulae in the expression of $p'''(s)$ we get a formula for the torsion:

$$\begin{aligned} p'(t) &= |p'| \boldsymbol{\tau} = \frac{dp}{ds} \frac{ds}{dt} = s' \boldsymbol{\tau} \Rightarrow |p'| = s' \rightarrow \\ p''(t) &= s'' \boldsymbol{\tau} + s' \boldsymbol{\tau}' = s'' \boldsymbol{\tau} + s'^2 \frac{d\boldsymbol{\tau}}{ds} = s'' \boldsymbol{\tau} + c s'^2 \boldsymbol{\nu} \rightarrow \\ p'''(t) &= s''' \boldsymbol{\tau} + s'' \boldsymbol{\tau}' + (c s'^2)' \boldsymbol{\nu} + c s'^2 \boldsymbol{\nu}' = \\ &= s''' \boldsymbol{\tau} + s'' s' \frac{d\boldsymbol{\tau}}{ds} + (c s'^2)' \boldsymbol{\nu} + c s'^3 \frac{d\boldsymbol{\nu}}{ds} = \\ &= s''' \boldsymbol{\tau} + s'' s' c \boldsymbol{\nu} + (c s'^2)' \boldsymbol{\nu} - c s'^3 (c \boldsymbol{\tau} + \vartheta \boldsymbol{\beta}) = \\ &= (s''' - c^2 s'^3) \boldsymbol{\tau} + (s'' s' c + c' s'^2 + 2c s' s'') \boldsymbol{\nu} - c s'^3 \vartheta \boldsymbol{\beta}, \end{aligned}$$

so that, through eq. (4.8), we get

$$\begin{aligned} p' \times p'' \cdot p''' &= s' \boldsymbol{\tau} \times (s'' \boldsymbol{\tau} + c s'^2 \boldsymbol{\nu}) \cdot [(s''' - c^2 s'^3) \boldsymbol{\tau} + \\ &= (s'' s' c + c' s'^2 + 2c s' s'') \boldsymbol{\nu} - c s'^3 \vartheta \boldsymbol{\beta}] = \\ &= -c^2 s'^6 \vartheta = -c^2 |p'|^6 \vartheta = -\frac{|p' \times p''|^2}{|p'|^6} |p'|^6 \vartheta, \end{aligned}$$

so that, finally,

$$\vartheta = -\frac{p' \times p'' \cdot p'''}{|p' \times p''|^2}.$$

To remark that while the curvature is linked to the second derivative of the curve, the torsion is a function also of the third derivative.

Unlike curvature, which is intrinsically positive, the torsion can be negative. In fact, still using the Frenet-Serret formulae,

$$\begin{aligned} p(s + \varepsilon) - p(s) &= \varepsilon p' + \frac{1}{2} \varepsilon^2 p'' + \frac{1}{6} \varepsilon^3 p''' + o(\varepsilon^3) = \\ &= \varepsilon \boldsymbol{\tau} + \frac{1}{2} \varepsilon^2 c \boldsymbol{\nu} + \frac{1}{6} \varepsilon^3 (c \boldsymbol{\nu})' + o(\varepsilon^3) = \\ &= \varepsilon \boldsymbol{\tau} + \frac{1}{2} \varepsilon^2 c \boldsymbol{\nu} + \frac{1}{6} \varepsilon^3 (c' \boldsymbol{\nu} - c^2 \boldsymbol{\tau} - c \vartheta \boldsymbol{\beta}) + o(\varepsilon^3) \rightarrow \\ &= (p(s + \varepsilon) - p(s)) \cdot \boldsymbol{\beta} = -\frac{1}{6} \varepsilon^3 c \vartheta + o(\varepsilon^3). \end{aligned}$$

The above dot product determines if the point $p(s + \varepsilon)$ is located, with respect to the osculating plane, on the side of β or on the opposite one, see Fig. 4.6: if following the curve for increasing values of s , $\varepsilon > 0$, the point passes into the semi-space of β from the opposite one, because $1/6 c \varepsilon^3 > 0$, it will be $\vartheta < 0$, while in the opposite case it will be $\vartheta > 0$.

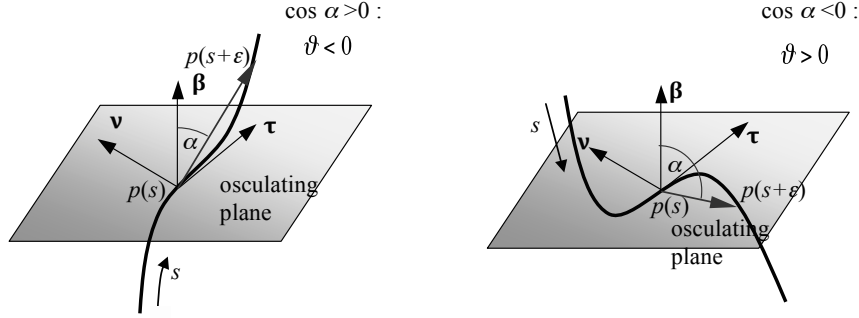

Figure 4.6: Torsion of a curve.

This result is intrinsic, i.e. it does not depend upon the choice of the parameter, hence of the positive orientation of the curve; in fact, ν is intrinsic, but changing the orientation of the curve, τ , and hence β , change of orientation.

4.8 Osculating sphere and circle

The *osculating sphere*³ to a curve at a point p is a sphere to which the curve tends to adhere in the neighborhood of p . Mathematically speaking, if q_s is the center of the sphere relative to point $p(s)$, then

$$|p(s + \varepsilon) - q_s|^2 = |p(s) - q_s|^2 + o(\varepsilon^3).$$

Using this definition, discarding the terms of order $o(\varepsilon^3)$ and using the Frenet-Serret formulae, we get:

$$\begin{aligned} |p(s + \varepsilon) - q_s|^2 &= |p(s) - q_s + \varepsilon p' + \frac{1}{2}\varepsilon^2 p'' + \frac{1}{6}\varepsilon^3 p''' + o(\varepsilon^3)|^2 = \\ &= |p(s) - q_s + \varepsilon \tau + \frac{1}{2}\varepsilon^2 c \nu + \frac{1}{6}\varepsilon^3 (c\nu)' + o(\varepsilon^3)|^2 = \\ &= |p(s) - q_s|^2 + 2\varepsilon(p(s) - q_s) \cdot \tau + \varepsilon^2 + \varepsilon^2 c(p(s) - q_s) \cdot \nu + \\ &= \frac{1}{3}\varepsilon^3(p(s) - q_s) \cdot (c'\nu - c^2\tau - c\vartheta\beta) + o(\varepsilon^3), \end{aligned}$$

which gives

$$\begin{aligned} (p(s) - q_s) \cdot \tau &= 0, \\ (p(s) - q_s) \cdot \nu &= -\frac{1}{c} = -\rho, \\ (p(s) - q_s) \cdot \beta &= -\frac{c'}{c^2\vartheta} = \frac{\rho'}{\vartheta}, \end{aligned}$$

³The word *osculating* comes from the latin word *osculo* that means to kiss; an osculating sphere or circle or plane is a geometric object that is very close to the curve, as close as two lovers are in a kiss.

and finally

$$q_s = p + \rho \boldsymbol{\nu} - \frac{\rho'}{\vartheta} \boldsymbol{\beta}, \quad (4.10)$$

so the center of the sphere belongs to the normal plane; the sphere is not defined for a plane curve. ρ is the *radius of curvature* of the curve, defined as

$$\rho = \frac{1}{c}.$$

The radius of the osculating sphere is

$$\rho_s = |p - q_s| = \sqrt{\rho^2 + \left(\frac{\rho'}{\vartheta}\right)^2}.$$

The intersection between the osculating sphere and the osculating plane at a same point p is the *osculating circle*. This circle has the property to share the same tangent in p with the curve and its radius is the radius of curvature, ρ . From eq. (4.10) we get the position of the osculating circle center q :

$$q = p + \rho \boldsymbol{\nu}. \quad (4.11)$$

An example can be seen in Fig. 4.7, where the osculating plane, circle and sphere are shown for a point p of a conical helix.

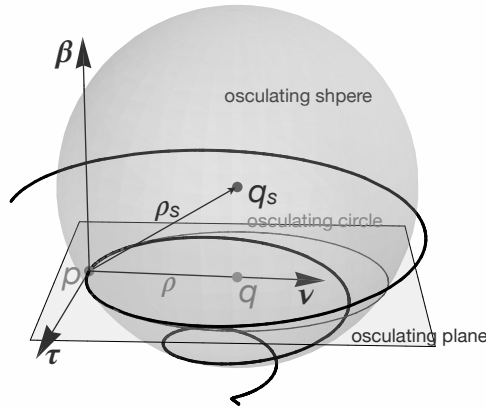

Figure 4.7: Osculating plane, circle and sphere for a point p of a conical helix.

The osculating circle is a diametral circle of the osculating sphere only when $q = q_s$, so if and only if

$$\frac{\rho'}{\vartheta} = -\frac{c'}{c^2\vartheta} = 0,$$

i.e. when the curvature is constant.

4.9 Evolute, involute and envelopes of plane curves

For any plane curve $\gamma(s)$, the center of the osculating circle q describes a curve $\delta(\sigma)$ that is called the *evolute* of $\gamma(s)$ (s and σ are curvilinear abscissae). A point q of the evolute is then given by eq. (4.11). We call *involute* of a curve $\alpha(s)$ a curve $\beta(\sigma)$ whose evolute is $\alpha(s)$. We call *envelop* of a family of plane curves $\varphi(s, \kappa)$, $\kappa \in \mathbb{R}$ being a parameter, a curve that is tangent, in each of its points, to the curve of $\varphi(s, \kappa)$ passing through that point.

Let us consider the evolute $\delta(\sigma)$ of a curve $\gamma(s)$; the tangent to $\delta(\sigma)$ is the vector, cf. eq. (4.11),

$$\boldsymbol{\tau}_\delta = \frac{dq}{d\sigma} = \frac{dq}{ds} \frac{ds}{d\sigma}.$$

But, cf. again eq. (4.11) and the Frenet-Serret formulae,

$$\frac{dq}{ds} = \frac{dp}{ds} + \frac{d\rho}{ds} \boldsymbol{\nu} + \rho \frac{d\boldsymbol{\nu}}{ds} = \boldsymbol{\tau} + \frac{d\rho}{ds} \boldsymbol{\nu} - \rho c \boldsymbol{\tau} = \frac{d\rho}{ds} \boldsymbol{\nu},$$

so

$$\boldsymbol{\tau}_\delta = \frac{dq}{d\sigma} = \frac{d\rho}{ds} \frac{ds}{d\sigma} \boldsymbol{\nu}.$$

Because

$$\left| \frac{dq}{d\sigma} \right| = |\boldsymbol{\nu}| = 1,$$

then

$$\frac{d\rho}{ds} \frac{ds}{d\sigma} = 1 \Rightarrow \frac{d\rho}{ds} = \frac{d\sigma}{ds}$$

and

$$\boldsymbol{\tau}_\delta = \boldsymbol{\nu}.$$

The evolute, $\delta(\sigma)$, of $\gamma(s)$ is hence the envelop of its principal normals $\boldsymbol{\nu}(s)$.

This result helps us in finding the equation of the involute $\beta(\sigma)$ of a curve $\gamma(s)$; let $p = p(s)$ be a point of $\gamma(s)$; then, if $b \in \beta(\sigma)$ it must be

$$(b - p) \cdot \boldsymbol{\nu} = 0$$

where $\boldsymbol{\nu}$ is the principal normal to $\gamma(s)$ in p , because $\gamma(s)$ is the evolute of $\beta(\sigma)$, which implies for the last result, that $\boldsymbol{\tau} = \boldsymbol{\nu}_\beta$, with $\boldsymbol{\tau}$ the tangent to $\gamma(s)$ in p and $\boldsymbol{\nu}_\beta$ the principal normal to $\beta(\sigma)$ in b , see Fig. 4.8.

Therefore,

$$b(s) - p(s) = f(s) \boldsymbol{\tau}(s) \rightarrow b(s) = p(s) + f(s) \boldsymbol{\tau}(s),$$

with $f = f(s)$ a scalar function of s ; to remark that $b = b(s)$, i.e. the arc-length s of $\gamma(s)$ is the parameter also for β , but in general $\sigma \neq s$. Upon differentiation we get

$$b'(s) = (1 - f'(s)) \boldsymbol{\tau}(s) + f(s) c(s) \boldsymbol{\nu}(s).$$

Then, because $b'(s) = |b'(s)| \boldsymbol{\tau}_\beta$ is orthogonal to $\boldsymbol{\nu}_\beta = \boldsymbol{\tau}$, it is parallel to $\boldsymbol{\nu}$ so it must be

$$1 - f'(s) = 0 \Rightarrow f(s) = a - s, \quad a \in \mathbb{R}.$$

Finally, the equation of the involute $\beta(s)$ to $\gamma(s)$ is

$$b(s) = p(s) + (a - s)\tau(s),$$

and we remark that the involute is not unique.

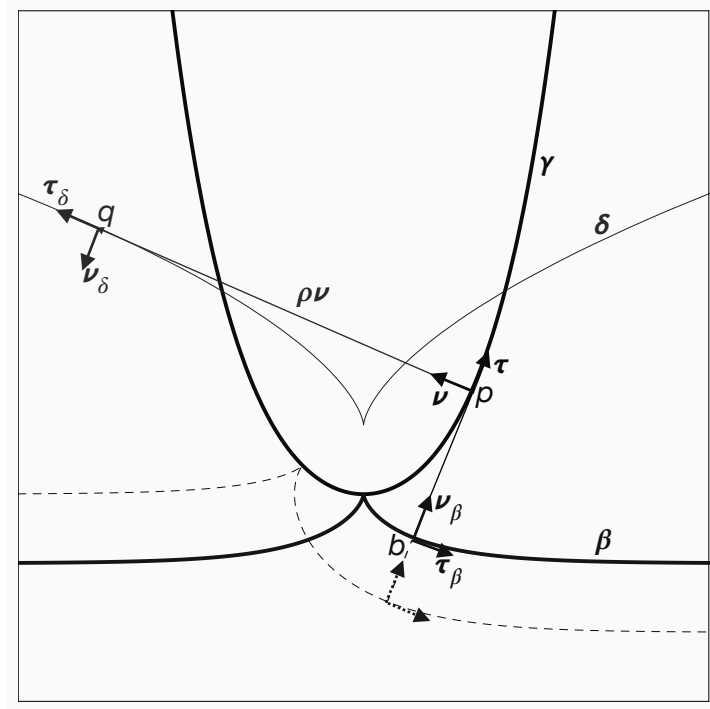

Figure 4.8: Evolute, δ , and involutes for $a = 0, \beta$, and $a = 1$, dashed, of a catenary γ .

4.10 The theorem of Bonnet

The curvature, $c(s)$, and the torsion, $\vartheta(s)$, are the only differential parameters that completely describe a curve. In other words: given two functions $c(s)$ and $\vartheta(s)$, then a curve exists with such a curvature and torsion (to remark that there are no conditions bounding these parameters). This is proved by the

Theorem 20. (*Bonnet's theorem*): *given two scalar functions $c(s) \in C^1$ and $\vartheta(s) \in C^0$, it always exists and is unique a curve $\gamma \in C^3$ whose curvilinear abscissa is s , curvature $c(s)$ and torsion $\vartheta(s)$.*

Proof. Let

$$\mathbf{e} = \begin{pmatrix} \tau \\ \nu \\ \beta \end{pmatrix}$$

the column vector whose elements are the vectors of the Frenet-Serret basis. Then

$$\frac{d\mathbf{e}(s)}{ds} = \mathbf{C}(s)\mathbf{e}(s) \tag{4.12}$$

with

$$\mathbf{C}(s) = \begin{bmatrix} 0 & c(s) & 0 \\ -c(s) & 0 & -\vartheta(s) \\ 0 & \vartheta(s) & 0 \end{bmatrix}$$

the matrix of Cartan. Adding the initial condition

$$\mathbf{e}(0) = \begin{pmatrix} \mathbf{e}_1 \\ \mathbf{e}_2 \\ \mathbf{e}_3 \end{pmatrix}$$

we have a Cauchy problem for the basis $\mathbf{e}(0)$. As known, such a problem admits a unique solution, i.e. we can associate to $c(s)$ and $\vartheta(s)$ a family of bases $\mathbf{e}(s)$ (that are orthonormal, because if one of them were not so, the Cartan's matrix should not be skew). Call $\boldsymbol{\tau}(s)$ the first vector of the basis $\mathbf{e}(s)$ and define the function

$$p(s) := p_0 + \int_0^s \boldsymbol{\tau}(s^*) ds^*;$$

$p(s)$ is the curve looked for (it depends upon an arbitrary point p_0 , i.e. upon an inessential rigid displacement). In fact, because $|\boldsymbol{\tau}| = 1$, then s is the curvilinear abscissa of the curve. Then, it is sufficient to write the Frenet-Serret equations identifying them with the system (4.12). \square

4.11 Canonic equations of a curve

We call *canonic equations* of a curve at a point p_0 the equations of the curve referred to the Frenet-Serret basis in p_0 . To this purpose, we expand the curve in a Taylor series of initial point p_0 :

$$p(s) = p_0 + s p'(0) + \frac{1}{2} s^2 p''(0) + \frac{1}{3!} s^3 p'''(0) + o(s^3).$$

In the Frenet-Serret basis,

$$p'(0) = \boldsymbol{\tau}(0), \quad p''(0) = c(0)\boldsymbol{\nu}(0), \quad p'''(0) = \left. \frac{dc\boldsymbol{\nu}}{ds} \right|_{s=0} = c'(0)\boldsymbol{\nu}(0) - c^2(0)\boldsymbol{\tau}(0) - c(0)\vartheta(0)\boldsymbol{\beta}(0),$$

so

$$p(s) = p_0 + s \boldsymbol{\tau}(0) + \frac{1}{2} s^2 c(0)\boldsymbol{\nu}(0) + \frac{1}{6} s^3 (-c^2(0)\boldsymbol{\tau}(0) + c'(0)\boldsymbol{\nu}(0) - c(0)\vartheta(0)\boldsymbol{\beta}(0)) + o(s^3).$$

The coordinates of a point $p(s)$ close to p_0 , in the basis $(\boldsymbol{\tau}(0), \boldsymbol{\nu}(0), \boldsymbol{\beta}(0))$, are hence

$$\begin{aligned} p_1(s) &= s - \frac{1}{6} c^2(0) s^3 + o(s^3), \\ p_2(s) &= \frac{1}{2} c(0) s^2 + \frac{1}{6} c'(0) s^3 + o(s^3), \\ p_3(s) &= -\frac{1}{6} c(0) \vartheta(0) s^3 + o(s^3). \end{aligned}$$

The projections of the curve onto the planes of the Frenet-Serret basis have hence, close to p_0 (i.e. retaining the first non null term in the expressions above), the following equations:

- on the osculating plane

$$\begin{cases} p_1(s) = s, \\ p_2(s) = \frac{1}{2}c(0)s^2, \end{cases}$$

or, eliminating s ,

$$p_2 = \frac{1}{2}c(0)p_1^2,$$

which is the equation of a parabola;

- on the rectifying plane

$$\begin{cases} p_1(s) = s, \\ p_3(s) = -\frac{1}{6}c(0)\vartheta(0)s^3, \end{cases}$$

or, eliminating s ,

$$p_3 = -\frac{1}{6}c(0)\vartheta(0)p_1^3,$$

which is the equation of a cubic parabola;

- on the normal plane

$$\begin{cases} p_2(s) = \frac{1}{2}c(0)s^2, \\ p_3(s) = -\frac{1}{6}c(0)\vartheta(0)s^3, \end{cases}$$

or, eliminating s ,

$$p_3^2 = \frac{2}{9} \frac{\vartheta^2(0)}{c(0)} p_2^3,$$

which is the equation of a semicubic parabola, with a cusp at the origin, hence a singular point, though the curve $p(s)$ is regular.

In Fig. 4.9 the example of the projected curves for a circular helix.

4.12 Exercises

1. Using the same definition of derivative of a curve, prove the relations in Sect. (4.2).
2. Prove the relations in eq. (4.2).
3. The curve whose polar equation is

$$r = a \theta, \quad a \in \mathbb{R},$$

is an *Archimede's spiral*. Find its curvature, its length for $\theta \in [0, 2\pi)$ and prove that any straight line passing by the origin is divided by the spiral in segments of constant length $2\pi a$ (that is why it is used to record disks).

4. The curve whose polar equation is

$$r = a e^{b\theta}, \quad a, b \in \mathbb{R},$$

is the *logarithmic spiral*. Prove that the origin is an asymptotic point of the curve, find its curvature and the length of the segment in which a straight line by the

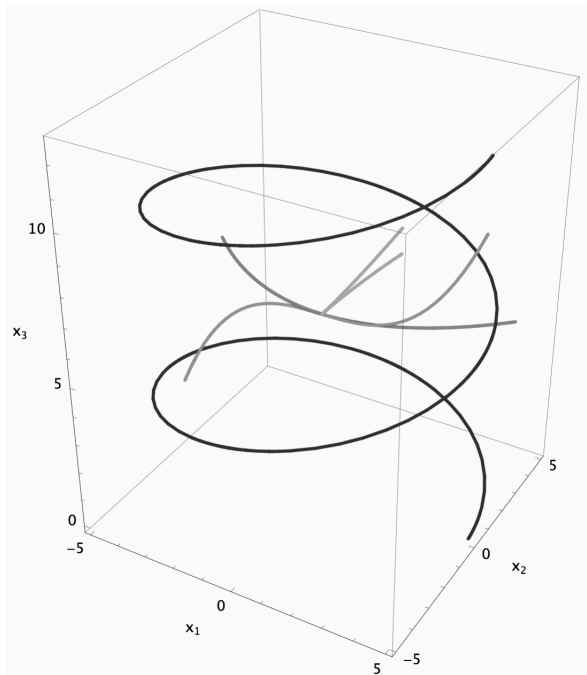

Figure 4.9: The projected curves of a circular helix.

origin is divided by two consecutive intersections with the spiral. Then prove that the curve is plane and its *equiangular property*: the angle α between $p(\theta) - o$ and $\tau(\theta)$ is constant.

5. The curve whose parametric equation is

$$p(\theta) = a(\cos \theta + \theta \sin \theta)\mathbf{e}_1 + a(\sin \theta - \theta \cos \theta)\mathbf{e}_2$$

with the parameter θ the angle formed by $p(\theta) - o$ with the x_1 -axis is the *involute of the circle*. Find its curvature and length for $\theta \in [0, 2\pi)$ and prove that the geometrical set of the points $p(\theta) + \rho(\theta)\nu(\theta)$ is exactly the circle of center o and radius a (that is why the involute of the circle is used to profile engrenages).

6. The curve whose parametric equation is

$$p(\theta) = a \cos \omega \theta \mathbf{e}_1 + a \sin \omega \theta \mathbf{e}_2 + b \omega \theta \mathbf{e}_3$$

is a *circular helix*, i.e. a *helix* that winds on a circular cylinder of radius a . Show that the angle formed by the helix and any generatrix of the cylinder is constant (a property that defines a helix in the general case). Then, find its length for $\theta \in [0, 2\pi)$, curvature, torsion and pitch (the distance, on a same generatrix, between two successive intersections with the helix). Prove then the *Bertrand's theorem*: a curve is a cylindrical helix if and only if the ratio $c/\vartheta = \text{const}$. Finally, prove that for the above circular helix there are two constants A and B such that

$$p' \times p'' = A\mathbf{u}(\theta) + B\mathbf{e}_3,$$

with

$$\mathbf{u} = \sin \omega \theta \mathbf{e}_1 - \cos \omega \theta \mathbf{e}_2;$$

find then A and B .

7. Find the equation of the *cycloid*, i.e. of the curve that is the trace of a point of a circle of radius r rolling without slipping on a horizontal axis. Calculate the length of the cycloid for a complete round of the circle, determine its curvature and show that the evolute of the cycloid is the cycloid itself (Huygens, 1659).
8. The planar curve whose parametric equation is

$$p(t) = t\mathbf{e}_1 + \cosh t\mathbf{e}_2$$

is the *catenary* (Jc. Bernoulli, 1690; Jn. Bernoulli, Leibniz, Huygens, 1691). It is the equilibrium curve of a heavy perfectly flexible and inextensible cable. Calculate the curvature of the catenary and the equation of its evolute and of its involutes.

9. The planar curve whose parametric equation is

$$p(t) = \left(\cos t + \ln \tan \frac{t}{2} \right) \mathbf{e}_1 + \sin t \mathbf{e}_2$$

is a *tractrix* (Perrault, 1670; Newton, 1676; Huygens, 1693). This is the curve along which an object moves, under the influence of friction, when pulled on a horizontal plane by a line segment attached to a tractor that moves at a right angle to the initial line between the object and the puller at an infinitesimal speed. Show that the length of the tangent to the tractrix between the points on the tractrix itself and the axis x is constant $\forall t$, calculate the length of the curve between t_1 and t_2 , calculate the curvature of the tractrix and finally show that its evolute is the catenary.

10. For the curve whose cylindrical equation is

$$\begin{cases} r = 1, \\ z = \sin \theta \end{cases}$$

find the highest curvature and determine whether or not it is planar.

11. Be $p = p(t)$ the path of a moving particle of masse m , t being the time. Define the velocity and the acceleration of p as, respectively, the first and second derivative of p with respect to t . Decompose these two vectors in the Frenet-Serret basis and interpret physically the result. Recalling the second Newton's Principle of mechanics, what about the forces on p ?

Chapter 5

Tensor analysis: fields, deformations

5.1 Introduction

In this chapter, we introduce the concepts of fields and deformations and the differential operators linked to these ones. Some fundamental theorems on field analysis are also recalled.

5.2 Scalar, vector and tensor fields

Let $\Omega \subset \mathcal{E}$ and $\mathbf{f} : \Omega \rightarrow \mathcal{V}$. We say that \mathbf{f} is *continuous at* $p \in \Omega \iff \forall$ sequence $\pi_n = \{p_n \in \Omega, n \in \mathbb{N}\}$ that converges to $p \in \mathcal{E}$, the sequence $\{\mathbf{v}_n = \mathbf{f}(p_n), n \in \mathbb{N}\}$ converges to $\mathbf{f}(p)$ in \mathcal{V} . The function $\mathbf{f}(p) : \Omega \rightarrow \mathcal{V}$ is a *vector field on* Ω if it is continuous at each $p \in \Omega$. In the same way we can define a *scalar field* $\varphi(p) : \Omega \rightarrow \mathbb{R}$ and a *tensor field*, $\mathbf{L}(p) : \Omega \rightarrow \text{Lin}(\mathcal{V})$ or $\mathbb{L}(p) : \Omega \rightarrow \mathbb{L}(\mathcal{V})$.

A *deformation* is any continuous and bijective function $f(p) : \Omega \rightarrow \mathcal{E}$, i.e. any transformation of a region $\Omega \subset \mathcal{E}$ into another region of \mathcal{E} ; bijectivity imposes that to any point $p \in \Omega$ corresponds one and only point in the transformed region, and vice-versa. This is a constraint imposed to a function from \mathcal{E} to \mathcal{E} to represent a physical deformation of a body.

Finally, the basic difference between fields/deformations and curves, is that a field or a deformation is defined over a subset of \mathcal{E} , not of \mathbb{R} . In practice, this implies that the components of the field/deformation are functions of three variables, the coordinates x_i of a point $p \in \Omega$.

5.3 Differentiation of fields, differential operators

Let $\mathbf{f}(p) : \Omega \rightarrow \mathcal{V}$; we say that \mathbf{f} is *differentiable in* $p_0 \in \Omega \iff \exists \text{grad}\mathbf{f} \in \text{Lin}(\mathcal{V})$ such that

$$\mathbf{f}(p_0 + \mathbf{u}) = \mathbf{f}(p_0) + \text{grad}\mathbf{f}(p_0) \mathbf{u} + o(\mathbf{u})$$

when $\mathbf{u} \rightarrow \mathbf{o}$. If \mathbf{f} is differentiable $\forall p \in \Omega$, $\text{grad}\mathbf{f}$ defines a tensor field on Ω called the *gradient of* \mathbf{f} . It is also possible to define higher order differential operators, using higher order tensors, but this will not be done here. If \mathbf{f} is continuous with $\text{grad}\mathbf{f} \forall p \in \Omega$, then \mathbf{f} is of class C^1 (*smooth*).

Let \mathbf{f} a vector field of class C^1 on Ω . Then the *divergence* of \mathbf{f} is the scalar field defined by

$$\text{div}\mathbf{f} := \text{tr}(\text{grad}\mathbf{f}),$$

while the *curl* of \mathbf{f} is the unique vector field $\text{curl}\mathbf{f}$ that satisfies the relation

$$(\text{grad}\mathbf{f} - \text{grad}\mathbf{f}^\top)\mathbf{u} = (\text{curl}\mathbf{f}) \times \mathbf{u} \quad \forall \mathbf{u} \in \mathcal{V}.$$

The *divergence of a tensor field* \mathbf{L} is the unique vector field $\text{div}\mathbf{L}$ that satisfies

$$(\text{div}\mathbf{L}) \cdot \mathbf{u} = \text{div}(\mathbf{L}^\top \mathbf{u}) \quad \forall \mathbf{u} \in \mathcal{V}.$$

Let $\varphi(p) : \Omega \rightarrow \mathbb{R}$ a scalar field over Ω . Similarly to what done for vector fields, we say that φ is *differentiable at* $p_0 \in \Omega \iff \exists \text{grad}\varphi \in \mathcal{V}$ such that

$$\varphi(p_0 + \mathbf{u}) = \varphi(p_0) + \text{grad}\varphi(p_0) \cdot \mathbf{u} + o(\mathbf{u})$$

when $\mathbf{u} \rightarrow \mathbf{o}$. If φ is differentiable $\forall p \in \Omega$, $\text{grad}\varphi$ defines a vector field on Ω called the *gradient of* φ . If $\text{grad}\varphi$ is differentiable, its gradient is the tensor $\text{grad}^{II}\varphi$ called *second gradient* or *Hessian*. It is immediate to show that under continuity assumption,

$$\text{grad}^{II}\varphi = (\text{grad}^{II}\varphi)^\top.$$

A *level set* of a scalar field $\varphi(p)$ is the set \mathcal{S}_L such that

$$\varphi(p) = \text{const.} \quad \forall p \in \mathcal{S}_L.$$

By the same definition of differentiability of $\varphi(p)$, we can prove that $\text{grad}\varphi(p)$ is a vector that is orthogonal to \mathcal{S}_L at p . The curves of \mathcal{E} that are tangent to $\text{grad}\varphi(p) \forall p \in \Omega$ are the *streamlines of* φ ; they have the property to be orthogonal to any \mathcal{S}_L of $\varphi \forall p \in \Omega$.

$\text{grad}\varphi$ allows to calculate the *directional derivative* of φ along any direction $\mathbf{n} \in \mathcal{S}$ as

$$\frac{d\varphi}{d\mathbf{n}} := \text{grad}\varphi \cdot \mathbf{n}.$$

The highest variation of φ is hence in the direction of $\text{grad}\varphi$, and $|\text{grad}\varphi|$ is the value of this variation; we remark also that $\text{grad}\varphi$ is a vector directed as the increasing values of φ .

Similarly, for a vector field \mathbf{f} the *directional derivative* along any direction $\mathbf{n} \in \mathcal{S}$ is defined as

$$\frac{d\mathbf{f}}{d\mathbf{n}} := \text{grad} \mathbf{f} \cdot \mathbf{n}.$$

Let ψ a scalar or vector field of class C^2 at least. Then, the *laplacian* $\Delta\psi$ of ψ is defined by

$$\Delta\psi := \text{div}(\text{grad}\psi).$$

By the linearity of the trace, and hence of the divergence, we see easily that the laplacian of a vector field is the vector field whose components are the laplacian of each corresponding component of the field. A field is said to be *harmonic* on Ω if its laplacian is null $\forall p \in \Omega$.

The definitions given above for differentiable field, gradient and class C^1 can be repeated *verbatim* for a deformation $f(p) : \Omega \rightarrow \mathcal{E}$.

Let φ, ψ two scalar fields, $\mathbf{u}, \mathbf{v}, \mathbf{w}$ vector fields, \mathbf{L} a tensor field and \mathbf{W} the axial tensor of \mathbf{w} . Then, the following properties hold:

$$\begin{aligned} \text{grad}(\varphi\psi) &= \varphi\text{grad}\psi + \psi\text{grad}\varphi, \\ \text{grad}(\varphi\mathbf{v}) &= \varphi\text{grad}\mathbf{v} + \mathbf{v} \otimes \text{grad}\varphi, \\ (\text{grad}\mathbf{v})\mathbf{v} &= (\text{curl}\mathbf{v}) \times \mathbf{v} + \frac{1}{2}\text{grad}\mathbf{v}^2, \\ \text{grad}(\mathbf{v} \cdot \mathbf{w}) &= (\text{grad}\mathbf{w})^\top \mathbf{v} + (\text{grad}\mathbf{v})^\top \mathbf{w} = (\text{grad}\mathbf{w})\mathbf{v} + (\text{grad}\mathbf{v})\mathbf{w} + \mathbf{v} \times \text{curl}\mathbf{w} + \mathbf{w} \times \text{curl}\mathbf{v}, \\ \text{grad}(\mathbf{u} \cdot \mathbf{v} \mathbf{w}) &= (\mathbf{u} \cdot \mathbf{v})\text{grad}\mathbf{w} + (\mathbf{w} \otimes \mathbf{u})\text{grad}\mathbf{v} + (\mathbf{w} \otimes \mathbf{v})\text{grad}\mathbf{u}, \\ \text{grad}\mathbf{v} \cdot \text{grad}\mathbf{v}^\top &= \text{div}((\text{grad}\mathbf{v})\mathbf{v} - (\text{div}\mathbf{v})\mathbf{v}) + (\text{div}\mathbf{v})^2, \\ \text{div}(\varphi\mathbf{v}) &= \varphi\text{div}\mathbf{v} + \mathbf{v} \cdot \text{grad}\varphi, \\ \text{div}(\mathbf{v} \otimes \mathbf{w}) &= \mathbf{v}\text{div}\mathbf{w} + (\text{grad}\mathbf{v})\mathbf{w}, \\ \text{div}(\mathbf{L}^\top \mathbf{v}) &= \mathbf{L} \cdot \text{grad}\mathbf{v} + \mathbf{v} \cdot \text{div}\mathbf{L}, \\ \text{div}(\varphi\mathbf{L}) &= \varphi\text{div}\mathbf{L} + \mathbf{L}\text{grad}\varphi, \\ \text{div}(\text{grad}\mathbf{v}^\top) &= \text{grad}(\text{div}\mathbf{v}), \\ \text{div}((\text{grad}\mathbf{v})\mathbf{v}) &= \text{grad}\mathbf{v} \cdot \text{grad}\mathbf{v}^\top + \mathbf{v} \cdot \text{grad}(\text{div}\mathbf{v}), \\ \text{div}(\mathbf{v} \times \mathbf{w}) &= \mathbf{w} \cdot \text{curl}\mathbf{v} - \mathbf{v} \cdot \text{curl}\mathbf{w}, \\ \text{div}(\varphi\mathbf{L}\mathbf{v}) &= \varphi\mathbf{L}^\top \cdot \text{grad}\mathbf{v} + \varphi\mathbf{v} \cdot \text{div}\mathbf{L}^\top + \mathbf{L}\mathbf{v} \cdot \text{grad}\varphi, \\ \text{div}(\text{curl}\mathbf{v}) &= \mathbf{0}, \\ \text{curl}(\varphi\mathbf{v}) &= \varphi\text{curl}\mathbf{v} + \text{grad}\varphi \times \mathbf{v}, \\ \text{curl}(\text{curl}\mathbf{v}) &= \text{grad}(\text{div}\mathbf{v}) - \Delta\mathbf{v}, \\ \text{curl}(\text{grad}\varphi) &= \mathbf{0}, \end{aligned}$$

$$\begin{aligned}\operatorname{curl}(\mathbf{v} \times \mathbf{w}) &= (\operatorname{grad} \mathbf{v})\mathbf{w} - (\operatorname{grad} \mathbf{w})\mathbf{v} + \mathbf{v}\operatorname{div} \mathbf{w} - \mathbf{w}\operatorname{div} \mathbf{v}, \\ \operatorname{curl} \mathbf{w} &= -\operatorname{div} \mathbf{W}, \\ \Delta(\varphi\psi) &= 2\operatorname{grad} \varphi \cdot \operatorname{grad} \psi + \varphi\Delta\psi + \psi\Delta\varphi, \\ \Delta(\mathbf{v} \cdot \mathbf{w}) &= 2\operatorname{grad} \mathbf{v} \cdot \operatorname{grad} \mathbf{w} + \mathbf{v} \cdot \Delta \mathbf{w} + \mathbf{w} \cdot \Delta \mathbf{v}.\end{aligned}$$

The proof of these properties is a good exercise for the reader (see also the book of Gurtin).

5.4 Theorems on fields

We recall here, without proof, some classical theorems on fields and operators.

Theorem 21. (*on harmonic fields*): if $\mathbf{v}(p)$ is a vector field of class $\geq C^2$ such that

$$\operatorname{div} \mathbf{v} = 0, \quad \operatorname{curl} \mathbf{v} = \mathbf{o},$$

then \mathbf{v} is harmonic: $\Delta \mathbf{v} = \mathbf{o}$.

Theorem 22. (*Potential theorem*): let $\mathbf{v}(p)$ a vector field of class $\geq C^1$ on a simply connected domain $\Omega \subset \mathcal{E}$; then

$$\operatorname{curl} \mathbf{v} = \mathbf{o} \iff \mathbf{v} = \operatorname{grad} \varphi$$

with $\varphi(p)$ a scalar field of class $\geq C^2$, the potential.

In what follows, Ω is a sufficiently regular region of \mathcal{E} , whose boundary is $\partial\Omega$ and the external normal $\mathbf{n} \in \mathcal{S}$.

Theorem 23. (*Divergence lemma*): let $\mathbf{v}(p)$ a vector field of class $\geq C^1$ on Ω ; then

$$\int_{\partial\Omega} \mathbf{v} \otimes \mathbf{n} \, ds = \int_{\Omega} \operatorname{grad} \mathbf{v} \, dv.$$

Theorem 24. (*Divergence or Gauss theorem*): let $\varphi, \mathbf{v}, \mathbf{L}$ respectively a scalar, vector and tensor field on Ω of class $\geq C^1$. Then

$$\begin{aligned}\int_{\partial\Omega} \varphi \mathbf{n} \, ds &= \int_{\Omega} \operatorname{grad} \varphi \, dv, \\ \int_{\partial\Omega} \mathbf{v} \cdot \mathbf{n} \, ds &= \int_{\Omega} \operatorname{div} \mathbf{v} \, dv, \\ \int_{\partial\Omega} \mathbf{L} \mathbf{n} \, ds &= \int_{\Omega} \operatorname{div} \mathbf{L} \, dv.\end{aligned}$$

Theorem 25. (Curl theorem): let $\mathbf{v}(p)$ a vector field of class $\geq C^1$ on Ω ; then

$$\int_{\partial\Omega} \mathbf{n} \times \mathbf{v} \, ds = \int_{\Omega} \operatorname{curl} \mathbf{v} \, dv.$$

Theorem 26. (Stokes theorem): let $\mathbf{v}(p)$ a vector field of class $\geq C^1$ on Ω and be Σ an open surface whose support is the closed line γ and $\mathbf{n} \in \mathcal{S}$ the normal, see Fig. 5.1. Then

$$\oint_{\gamma} \mathbf{v} \cdot d\mathbf{l} = \int_{\Sigma} \operatorname{curl} \mathbf{v} \cdot \mathbf{n} \, ds.$$

The parametric equation of γ must be chosen in such a way that

$$p'(t_1) \times p'(t_2) \cdot \mathbf{n} > 0 \quad \forall t_2 > t_1.$$

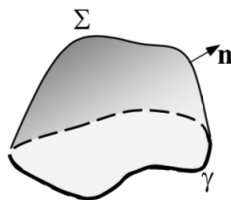

Figure 5.1: Scheme for the Stokes theorem.

Theorem 27. (Green's formula): let $\varphi(p), \psi(p)$ two scalar fields on Ω of class $\geq C^2$; then

$$\int_{\partial\Omega} \left(\psi \frac{d\varphi}{d\mathbf{n}} - \varphi \frac{d\psi}{d\mathbf{n}} \right) ds = \int_{\Omega} (\psi \Delta\varphi - \varphi \Delta\psi) dv.$$

Theorem 28. (Flux theorem): let $\mathbf{v}(p)$ a vector field of class $\geq C^1$ on an open subset \mathbf{R} of \mathcal{E} . Then

$$\operatorname{div} \mathbf{v} = 0 \iff \int_{\partial\Omega} \mathbf{v} \cdot \mathbf{n} \, ds = 0 \quad \forall \Omega \subset \mathbf{R}.$$

5.5 Differential operators in Cartesian coordinates

In what follows, $f, \mathbf{v}, \mathbf{L}$ are respectively a scalar, vector and tensor field. The Cartesian components¹ of the differential operators are²

$$\begin{aligned}(\operatorname{grad} f)_i &= f_{,i}, \\(\operatorname{grad} \mathbf{v})_{ij} &= v_{i,j}, \\div \mathbf{v} &= v_{i,i}, \\(\operatorname{div} \mathbf{L})_i &= L_{ij,j}, \\\Delta f &= f_{,ii}, \\(\Delta \mathbf{v})_i &= \Delta v_i = v_{i,jj}, \\\operatorname{curl} \mathbf{v} &= (v_{3,2} - v_{2,3}, v_{1,3} - v_{3,1}, v_{2,1} - v_{1,2}).\end{aligned}$$

The so-called *operator nabla* ∇ :

$$\nabla := \frac{\partial \cdot}{\partial x_i} \mathbf{e}_i = \frac{\partial \cdot}{\partial x_1} \mathbf{e}_1 + \frac{\partial \cdot}{\partial x_2} \mathbf{e}_2 + \frac{\partial \cdot}{\partial x_3} \mathbf{e}_3$$

is often used to indicate the differential operators:

$$\begin{aligned}\operatorname{grad} f &= \nabla f, \\\operatorname{div} \mathbf{v} &= \nabla \cdot \mathbf{v}, \\\operatorname{curl} \mathbf{v} &= \nabla \times \mathbf{v}, \\\Delta f &= \nabla^2 f.\end{aligned}$$

5.6 Differential operators in cylindrical coordinates

The cylindrical coordinates ρ, θ, z of a point p , whose Cartesian coordinates in the (fixed) frame $\{o; \mathbf{e}_1, \mathbf{e}_2, \mathbf{e}_3\}$ are $p = (x_1, x_2, x_3)$, are shown in Fig. 5.2. They are related together by

$$\begin{aligned}\rho &= \sqrt{x_1^2 + x_2^2}, \\\theta &= \arctan \frac{x_2}{x_1}, \\z &= x_3,\end{aligned}$$

or conversely

$$\begin{aligned}x_1 &= \rho \cos \theta, \\x_2 &= \rho \sin \theta, \\x_3 &= z.\end{aligned}$$

To notice that $\rho \geq 0$ and that the *anomaly* θ is bounded by $0 \leq \theta < 2\pi$.

¹In the following formulae, the Einstein summation rule holds.

²The comma indicates partial derivative, e.g. $f_{i,j} = \frac{\partial f_i}{\partial x_j}$.

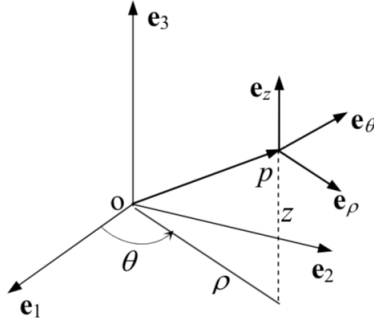

Figure 5.2: Cylindrical coordinates.

In the (local) frame $\{p; \mathbf{e}_\rho, \mathbf{e}_\theta, \mathbf{e}_z\}$, the differential operators are

$$\nabla f = \left(f_{,\rho}, \frac{1}{\rho} f_{,\theta}, f_{,z} \right),$$

$$\Delta f = \frac{1}{\rho} (\rho f_{,\rho})_{,\rho} + \frac{1}{\rho^2} f_{,\theta\theta} + f_{,zz},$$

$$\nabla \mathbf{v} = \begin{bmatrix} v_{\rho,\rho} & \frac{1}{\rho} (v_{\rho,\theta} - v_\theta) & v_{\rho,z} \\ v_{\theta,\rho} & \frac{1}{\rho} (v_{\theta,\theta} + v_\rho) & v_{\theta,z} \\ v_{z,\rho} & \frac{1}{\rho} v_{z,\theta} & v_{z,z} \end{bmatrix},$$

$$\operatorname{div} \mathbf{v} = v_{\rho,\rho} + \frac{1}{\rho} (v_{\theta,\theta} + v_\rho) + v_{z,z},$$

$$\operatorname{curl} \mathbf{v} = \left(\frac{1}{\rho} v_{z,\theta} - v_{\theta,z}, v_{\rho,z} - v_{z,\rho}, \frac{1}{\rho} ((\rho v_\theta)_{,\rho} - v_{\rho,\theta}) \right),$$

$$\operatorname{div} \mathbf{L} = \begin{bmatrix} \frac{1}{\rho} ((\rho L_{\rho\rho})_{,\rho} + L_{\rho\theta,\theta} - L_{\theta\theta}) + L_{\rho z,z} \\ L_{\theta\rho,\rho} + \frac{1}{\rho} (L_{\theta\theta,\theta} + L_{\rho\theta} + L_{\theta\rho}) + L_{\theta z,z} \\ \frac{1}{\rho} ((\rho L_{z\rho})_{,\rho} + L_{z\theta,\theta}) + L_{z z,z} \end{bmatrix},$$

$$\Delta \mathbf{v} = \begin{pmatrix} \Delta v_\rho \\ \Delta v_\theta \\ \Delta v_z \end{pmatrix} = \begin{pmatrix} \frac{1}{\rho} (\rho v_{\rho,\rho})_{,\rho} + \frac{1}{\rho^2} v_{\rho,\theta\theta} + v_{\rho,zz} - \frac{1}{\rho^2} (v_\rho + 2v_{\theta,\theta}) \\ \frac{1}{\rho} (\rho v_{\theta,\rho})_{,\rho} + \frac{1}{\rho^2} v_{\theta,\theta\theta} + v_{\theta,zz} - \frac{1}{\rho^2} (v_\theta - 2v_{\rho,\theta}) \\ \frac{1}{\rho} (\rho v_{z,\rho})_{,\rho} + \frac{1}{\rho^2} v_{z,\theta\theta} + v_{z,zz} \end{pmatrix}.$$

5.7 Differential operators in spherical coordinates

The spherical coordinates r, φ, θ of a point p , whose Cartesian coordinates in the (fixed) frame $\{o; \mathbf{e}_1, \mathbf{e}_2, \mathbf{e}_3\}$ are $p = (x_1, x_2, x_3)$, are shown in Fig. 5.3. They are related together by

$$\begin{aligned} r &= \sqrt{x_1^2 + x_2^2 + x_3^2}, \\ \varphi &= \arctan \frac{\sqrt{x_1^2 + x_2^2}}{x_3}, \\ \theta &= \arctan \frac{x_2}{x_1}, \end{aligned}$$

or conversely

$$\begin{aligned} x_1 &= r \cos \theta \sin \varphi, \\ x_2 &= r \sin \theta \sin \varphi, \\ x_3 &= r \cos \varphi. \end{aligned}$$

To notice that $r \geq 0$ and that the *anomaly* θ is bounded by $0 \leq \theta < 2\pi$ while the *colatitude* φ by $0 \leq \varphi \leq \pi$.

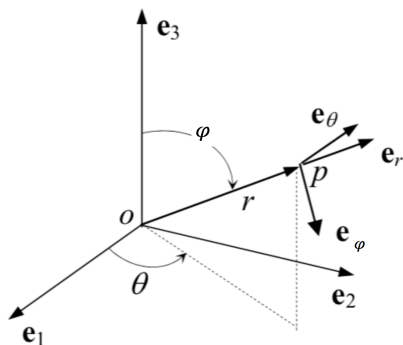

Figure 5.3: Spherical coordinates.

In the (local) frame $\{p; \mathbf{e}_r, \mathbf{e}_\varphi, \mathbf{e}_\theta\}$, the differential operators are

$$\begin{aligned} \nabla f &= \left(f_{,r}, \frac{1}{r} f_{,\varphi}, \frac{1}{r \sin \varphi} f_{,\theta} \right), \\ \Delta f &= \frac{1}{r^2} (r^2 f_{,r})_{,r} + \frac{1}{r^2 \sin \varphi} (f_{,\theta\theta} + (f_{,\varphi} \sin \varphi)_{,\varphi}), \\ \nabla \mathbf{v} &= \begin{bmatrix} v_{r,r} & \frac{1}{r} (v_{r,\varphi} - v_\varphi) & \frac{1}{r} \left(\frac{1}{\sin \varphi} v_{r,\theta} - v_\theta \right) \\ v_{\varphi,r} & \frac{1}{r} (v_{\varphi,\varphi} + v_r) & \frac{1}{r} \left(\frac{1}{\sin \varphi} v_{\varphi,\theta} - v_\theta \cot \varphi \right) \\ v_{\theta,r} & \frac{1}{r} v_{\theta,\varphi} & \frac{1}{r} \left(\frac{1}{\sin \varphi} v_{\theta,\theta} + v_r + v_\varphi \cot \varphi \right) \end{bmatrix}, \end{aligned}$$

$$\begin{aligned} \operatorname{div} \mathbf{v} &= \frac{1}{r^2} (r^2 v_r)_{,r} + \frac{1}{r \sin \varphi} (v_{\varphi,\varphi} \sin \theta + v_{\theta,\theta}), \\ \operatorname{curl} \mathbf{v} &= \left(\frac{1}{r \sin \varphi} (v_{\theta,\varphi} \sin \theta - v_{\varphi,\theta}), \frac{1}{r \sin \varphi} v_{r,\theta} - \frac{1}{r} (r v_\theta)_{,r}, \frac{1}{r} ((r v_\varphi)_{,r} - v_{r,\varphi}) \right), \\ \operatorname{div} \mathbf{L} &= \left(\begin{aligned} &\frac{1}{r^2} (r^2 L_{rr})_{,r} + \frac{1}{r} L_{r\varphi,\varphi} + \frac{1}{r \sin \varphi} L_{r\theta,\theta} - \frac{L_{\varphi\varphi} + L_{\theta\theta}}{r} + \frac{\cot \varphi}{r} L_{r\varphi} \\ &\frac{1}{r^2} (r^2 L_{\varphi r})_{,r} + \frac{1}{r} L_{\varphi\varphi,\varphi} + \frac{1}{r \sin \varphi} L_{\varphi\theta,\theta} + \frac{1}{r} L_{r\varphi} + \frac{\cot \varphi}{r} (L_{\varphi\varphi} - L_{\theta\theta}) \\ &\frac{1}{r^2} (r^2 L_{\theta r})_{,r} + \frac{1}{r} L_{\theta\varphi,\varphi} + \frac{1}{r \sin \varphi} L_{\theta\theta,\theta} + \frac{1}{r} L_{r\theta} + \frac{\cot \varphi}{r} (L_{\varphi\theta} + L_{\theta\varphi}) \end{aligned} \right), \\ \Delta \mathbf{v} &= \left(\begin{aligned} &v_{r,rr} + \frac{2v_{r,r}}{r} + \frac{v_{r,\varphi\varphi} - 2v_{\varphi,\varphi}}{r^2} + \frac{v_{r,\varphi} - 2v_\varphi}{r^2 \tan \varphi} + \frac{1}{r^2 \sin \varphi} \left(\frac{v_{r,\theta\theta}}{\sin \varphi} - 2v_{\theta,\theta} \right) - \frac{2v_r}{r^2} \\ &v_{\varphi,rr} + \frac{2v_{\varphi,r}}{r} + \frac{v_{\varphi,\varphi\varphi} + 2v_{r,\varphi}}{r^2} + \frac{v_{\varphi,\varphi} - v_\varphi \cot \varphi}{r^2 \tan \varphi} + \frac{1}{r^2 \sin \varphi} \left(\frac{v_{\varphi,\theta\theta}}{\sin \varphi} - 2v_{\theta,\theta} \cot \varphi \right) - \frac{v_\varphi}{r^2} \\ &v_{\theta,rr} + \frac{2v_{\theta,r}}{r} + \frac{v_{\theta,\varphi\varphi}}{r^2} + \left(v_{\theta,\varphi} + \frac{2v_{\varphi,\theta}}{\sin \varphi} \right) \frac{1}{r^2 \tan \varphi} + \frac{1}{r^2 \sin \varphi} \left(\frac{v_{\theta,\theta\theta}}{\sin \varphi} + 2v_{r,\theta} \right) - \frac{v_\theta}{r^2 \sin^2 \varphi} \end{aligned} \right). \end{aligned}$$

5.8 Exercices

1. Consider a rigid body \mathbf{B} , and a point $p_0 \in \mathbf{B}$. From the kinematics of rigid bodies, we now that the velocity of another point $p \in \mathbf{B}$ is given by

$$\mathbf{v}(p) = \mathbf{v}(p_0) + \boldsymbol{\omega} \times (p - p_0),$$

with $\boldsymbol{\omega}$ the angular velocity. Prove that

$$\boldsymbol{\omega} = \frac{1}{2} \operatorname{curl} \mathbf{v}.$$

2. Prove the relations at the end of Sect. 5.3.
3. Prove the three forms of the Gauss Theorem using the Divergence lemma.
4. Make use of the tensor form of the Gauss Theorem to prove the Curl Theorem.
5. Prove the following identities using the Gauss theorem:

$$\begin{aligned} \int_{\partial\Omega} \mathbf{v} \cdot \mathbf{L} \mathbf{n} \, ds &= \int_{\Omega} (\mathbf{v} \cdot \operatorname{div} \mathbf{L} + \mathbf{L} \cdot \nabla \mathbf{v}) \, dv, \\ \int_{\partial\Omega} (\mathbf{L} \mathbf{n}) \otimes \mathbf{v} \, ds &= \int_{\Omega} ((\operatorname{div} \mathbf{L}) \otimes \mathbf{v} + \mathbf{L} (\nabla \mathbf{v}^\top)) \, dv, \\ \int_{\partial\Omega} (\mathbf{w} \cdot \mathbf{n}) \mathbf{v} \, ds &= \int_{\Omega} (\mathbf{v} \operatorname{div} \mathbf{w} + (\nabla \mathbf{v}) \mathbf{w}) \, dv. \end{aligned}$$

Chapter 6

Curvilinear coordinates

6.1 Introduction

All the developments done in the previous Chapters are intended for the case where algebraic and differential operators are expressed in a Cartesian frame, i.e. with *rectangular coordinates*. The points of \mathcal{E} are thus referred to a system of coordinates taken along straight lines that are mutually orthogonal and with the same unit along each one of the directions of the frame. Though this is a very important and common case, it is not the only possibility and in many cases non rectangular coordinate frames are used or arise in the mathematical developments (a typical example is that of the geometry of surfaces, see Chapter 7). A non rectangular coordinate frame is a frame where coordinates can be taken along non orthogonal directions, or along some lines that intersect at right angles but that are not straight lines or even when both of these situations occur. This situation is often denoted in the literature as that of *curvilinear coordinates*; the transformations to be done to algebraic and differential operators in the case of curvilinear coordinates is the topic of this Chapter.

6.2 Curvilinear coordinates, metric tensor

Let us consider an arbitrary origin o of \mathcal{E} and an orthonormal basis $e = \{\mathbf{e}_1, \mathbf{e}_2, \mathbf{e}_3\}$ of \mathcal{V} ; we will indicate the coordinates of a point $p \in \mathcal{E}$ with respect to the frame $\mathbb{R} = \{o; \mathbf{e}_1, \mathbf{e}_2, \mathbf{e}_3\}$ by $x_k : p = (x_1, x_2, x_3)$. Then, we consider also another set of coordinate lines for \mathcal{E} , where the position of a point $p \in \mathcal{E}$ with respect to the same arbitrary origin o of \mathcal{E} is now determined by a set of three numbers $z^j : p = \{z^1, z^2, z^3\}$. Nothing is a-priori asked to coordinates z^j , namely they do not need to be a set of Cartesian coordinates, i.e. referring to an orthonormal basis of \mathcal{V} . In principle, the coordinates z^j can be taken along non straight lines, that do not need to be mutually orthogonal at o and also with different units along each line. That is why we call the z^j s *curvilinear coordinates*, see Fig. 6.1. Any point $p \in \mathcal{E}$ can be identified by either set of coordinates; mathematically, this means that there must be an isomorphism between the x_k s and the z^j s, i.e. invertible relations

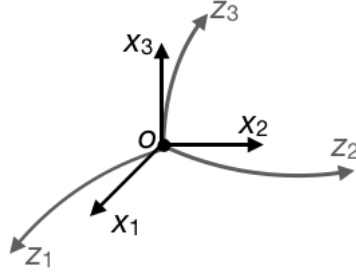

Figure 6.1: Cartesian and curvilinear coordinates.

of the kind

$$z^j = z^j(x_1, x_2, x_3) = z^j(x_k), \quad x_k = x_k(z^1, z^2, z^3) = x_k(z^j) \quad \forall j, k = 1, 2, 3 \quad (6.1)$$

exist between the two sets of coordinates. The distance between two points $p, q \in \mathcal{E}$ is

$$s = \sqrt{(p - q) \cdot (p - q)} = \sqrt{(x_k^p - x_k^q)(x_k^p - x_k^q)}$$

but this is no longer true for curvilinear coordinates:

$$s \neq \sqrt{(z^{jp} - z^{jq})(z^{jp} - z^{jq})}.$$

However, if $p \rightarrow q$, we can define

$$dx_k = x_k^p - x_k^q, \quad dz^j = z^{jp} - z^{jq},$$

so using eq. (6.1)₂

$$dx_k = \frac{\partial x_k}{\partial z^j} dz^j. \quad (6.2)$$

The (infinitesimal) distance between p and q will then be

$$ds = \sqrt{dx_k dx_k} = \sqrt{\frac{\partial x_k}{\partial z^j} \frac{\partial x_k}{\partial z^l} dz^j dz^l} = \sqrt{g_{jl} dz^j dz^l},$$

where

$$g_{jl} = g_{lj} = \frac{\partial x_k}{\partial z^j} \frac{\partial x_k}{\partial z^l} \quad (6.3)$$

are the *covariant*¹ components of the metric tensor \mathbf{g} . To notice that, as \mathbf{g} defines a positive quadratic form (the length of a vector), it is a positive definite symmetric tensor, so

$$\det \mathbf{g} > 0. \quad (6.4)$$

Coming back to the vector notation, from eq. (6.2) we get

$$dx = dx_i \mathbf{e}_i = \frac{\partial x_i}{\partial z^k} dz^k \mathbf{e}_i;$$

¹The notion of co- and contra-variant components will be detailed later.

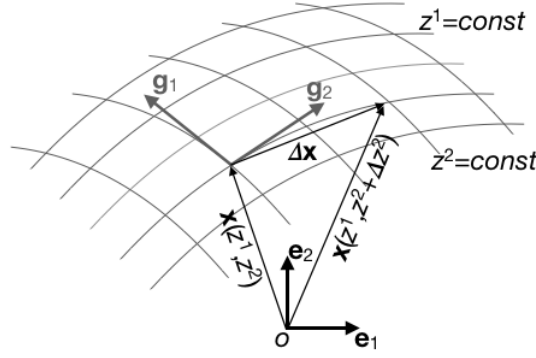

Figure 6.2: Tangent vectors to the curvilinear coordinates lines.

introducing the vector \mathbf{g}_k ,

$$\mathbf{g}_k := \frac{\partial x_i}{\partial z^k} \mathbf{e}_i, \quad (6.5)$$

we can write

$$dx = dz^k \mathbf{g}_k.$$

We see hence that a vector dx can be expressed as a linear combination of the vectors \mathbf{g}_k ; these ones form therefore a basis, called the *local basis*. Generally speaking, $\mathbf{g}_k \notin \mathcal{S}$ and it is clearly tangent to the lines $z^j = \text{const}$. This can be seen in Fig. 6.2 for a two-dimensional case:

$$dx = \lim_{\Delta \mathbf{x} \rightarrow 0} \Delta \mathbf{x} = \lim_{\Delta \mathbf{x} \rightarrow 0} \frac{x_i(z^1, z^2 + \Delta z^2, z^3) - x_i(z^1, z^2, z^3)}{\Delta z^2} \Delta z^2 \mathbf{e}_i = \frac{\partial x_i}{\partial z^2} \mathbf{e}_i dz^2 = \mathbf{g}_2 dz^2.$$

Then

$$\mathbf{g}_k \cdot \mathbf{g}_l = \frac{\partial x_i}{\partial z^k} \mathbf{e}_i \cdot \frac{\partial x_j}{\partial z^l} \mathbf{e}_j = \frac{\partial x_i}{\partial z^k} \frac{\partial x_j}{\partial z^l} \delta_{ij} = g_{kl}, \quad (6.6)$$

i.e. the components of the metric tensor \mathbf{g} are the scalar products of the tangent vectors \mathbf{g}_k s. If the curvilinear coordinates are *orthogonal*, i.e. if $\mathbf{g}_h \cdot \mathbf{g}_k = 0 \forall h, k = 1, 2, 3, h \neq k$, then \mathbf{g} is diagonal. If, in addition, $\mathbf{g}_k \in \mathcal{S} \forall k = 1, 2, 3$, then $\mathbf{g} = \mathbf{I}$: it is the case of Cartesian coordinates. As an example, let us consider the case of polar coordinates,

$$\begin{cases} x_1 = r \cos \theta, \\ x_2 = r \sin \theta, \end{cases} \quad \begin{cases} z^1 = r = \sqrt{x_1^2 + x_2^2}, \\ z^2 = \theta = \arctan \frac{x_2}{x_1}. \end{cases}$$

Hence, Fig. 6.3,

$$\begin{aligned} \mathbf{g}_1 &= \frac{\partial x_1}{\partial z^1} \mathbf{e}_1 + \frac{\partial x_2}{\partial z^1} \mathbf{e}_2 = \cos \theta \mathbf{e}_1 + \sin \theta \mathbf{e}_2 = \mathbf{e}_r, \\ \mathbf{g}_2 &= \frac{\partial x_1}{\partial z^2} \mathbf{e}_1 + \frac{\partial x_2}{\partial z^2} \mathbf{e}_2 = -r \sin \theta \mathbf{e}_1 + r \cos \theta \mathbf{e}_2 = r \mathbf{e}_\theta. \end{aligned}$$

To remark that $|\mathbf{g}_1| = 1$ but $|\mathbf{g}_2| \neq 1$ and it is variable with the position.

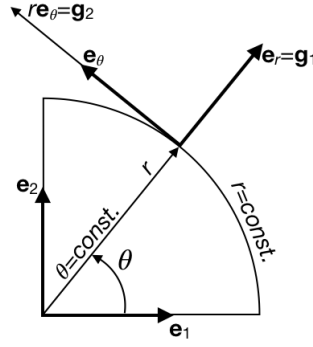

Figure 6.3: Tangent vectors to the polar coordinates lines.

6.3 Co- and contra-variant components

The notion of *co- and contra-variant components* is important in the geometry of surfaces. A geometrical way to introduce the concept of covariant and contravariant components is to consider how to represent a vector \mathbf{v} in the z -system. There are basically two ways, cf. Fig. 6.4, referred, for the sake of simplicity, to a planar case:

- i. contravariant components: \mathbf{v} is projected parallel to z^1 and z^2 ; they are indicated by superscripts: $\mathbf{v} = (v^1, v^2, v^3)$;
- ii. covariant components: \mathbf{v} is projected perpendicularly to z^1 and z^2 ; they are indicated by subscripts: $\mathbf{v} = (v_1, v_2, v_3)$;

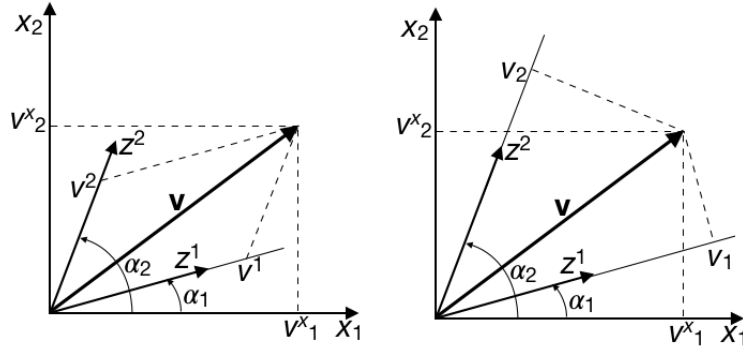

Figure 6.4: Contravariant, left, and covariant, right, components of a vector in a plane.

Still referring to the planar case in Fig. 6.4, if the Cartesian components² of \mathbf{v} are $\mathbf{v} = (v_1^x, v_2^x)$, we get

$$\begin{cases} v^1 = h(v_1^x \sin \alpha_2 - v_2^x \cos \alpha_2), \\ v^2 = h(-v_1^x \sin \alpha_1 + v_2^x \cos \alpha_1), \end{cases} \quad \begin{cases} v_1 = v_1^x \cos \alpha_1 + v_2^x \sin \alpha_1, \\ v_2 = v_1^x \cos \alpha_2 + v_2^x \sin \alpha_2, \end{cases} \quad (6.7)$$

and conversely

$$\begin{cases} v_1^x = v^1 \cos \alpha_1 + v^2 \cos \alpha_2, \\ v_2^x = v^1 \sin \alpha_1 + v^2 \sin \alpha_2, \end{cases} \quad \begin{cases} v_1^x = h(v_1 \sin \alpha_2 - v_2 \sin \alpha_1), \\ v_2^x = h(-v_1 \cos \alpha_2 + v_2 \cos \alpha_1), \end{cases} \quad (6.8)$$

²In the following, we use the superscript x to indicate a Cartesian component.

with

$$h = \frac{1}{\sin(\alpha_2 - \alpha_1)}.$$

It is apparent that the Cartesian coordinates are at the same time co- and contra-variant. Still on a planar scheme, we can see how to pass from a system of coordinates to another one, cf. Fig. 6.5 For a point p the Cartesian coordinates (x_1, x_2) are related to the

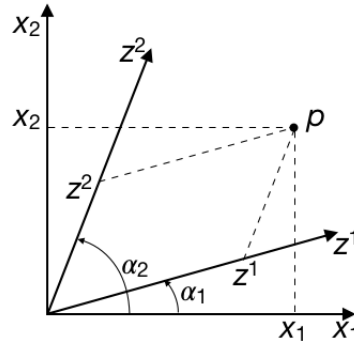

Figure 6.5: Relation between Cartesian and contravariant components.

contravariant ones by

$$\begin{aligned} x_1 &= z^1 \cos \alpha_1 + z^2 \cos \alpha_2, \\ x_2 &= z^1 \sin \alpha_1 + z^2 \sin \alpha_2, \end{aligned}$$

and conversely

$$\begin{aligned} z^1 &= h(x_1 \sin \alpha_2 - x_2 \cos \alpha_2), \\ z^2 &= h(-x_1 \sin \alpha_1 + x_2 \cos \alpha_1). \end{aligned}$$

So, differentiating we get

$$\begin{aligned} \frac{\partial x_1}{\partial z^1} &= \cos \alpha_1, & \frac{\partial x_1}{\partial z^2} &= \cos \alpha_2, \\ \frac{\partial x_2}{\partial z^1} &= \sin \alpha_1, & \frac{\partial x_2}{\partial z^2} &= \sin \alpha_2, \end{aligned}$$

and

$$\begin{aligned} \frac{\partial z^1}{\partial x_1} &= h \sin \alpha_2, & \frac{\partial z^1}{\partial x_2} &= -h \cos \alpha_2, \\ \frac{\partial z^2}{\partial x_1} &= -h \sin \alpha_1, & \frac{\partial z^2}{\partial x_2} &= h \cos \alpha_1. \end{aligned}$$

Injecting these expressions into eqs. (6.7) and (6.8) gives

$$\begin{aligned} v_1 &= v_1^x \frac{\partial x_1}{\partial z^1} + v_2^x \frac{\partial x_2}{\partial z^1}, \\ v_2 &= v_1^x \frac{\partial x_1}{\partial z^2} + v_2^x \frac{\partial x_2}{\partial z^2}, \end{aligned} \quad \rightarrow \quad v_i = \frac{\partial x_k}{\partial z^i} v_k^x \quad (6.9)$$

and

$$\begin{aligned} v^1 &= v_1^x \frac{\partial z^1}{\partial x_1} + v_2^x \frac{\partial z^1}{\partial x_2}, \\ v^2 &= v_1^x \frac{\partial z^2}{\partial x_1} + v_2^x \frac{\partial z^2}{\partial x_2}, \end{aligned} \rightarrow v^i = \frac{\partial z^i}{\partial x_k} v_k^x. \quad (6.10)$$

If now we calculate

$$g_{hi} v^i = g_{hi} \frac{\partial z^i}{\partial x_k} v_k^x,$$

from eq. (6.3) and by the chain rule³ we get

$$\begin{aligned} g_{hi} v^i &= \frac{\partial x_j}{\partial z^h} \frac{\partial x_j}{\partial z^i} \frac{\partial z^i}{\partial x_k} v_k^x \\ &= \frac{\partial x_j}{\partial z^h} \frac{\partial x_j}{\partial x_k} v_k^x = \frac{\partial x_j}{\partial z^h} \delta_{jk} v_k^x = \frac{\partial x_k}{\partial z^h} v_k^x = v_h, \end{aligned}$$

i.e. we obtain the rule of *lowering of the indices* for passing from contravariant to covariant components:

$$v_h = g_{hi} v^i.$$

Introducing the *inverse*⁴ to g_{hi} as

$$g^{hi} = \frac{\partial z^h}{\partial x_k} \frac{\partial z^i}{\partial x_k}, \quad (6.11)$$

we get, still using the chain rule,

$$\begin{aligned} g^{hi} v_i &= g^{hi} \frac{\partial x_k}{\partial z^i} v_k^x = \frac{\partial z^h}{\partial x_j} \frac{\partial z^i}{\partial x_j} \frac{\partial x_k}{\partial z^i} v_k^x \\ &= \frac{\partial z^h}{\partial x_j} \frac{\partial x_k}{\partial x_j} v_k^x = \frac{\partial z^h}{\partial x_j} \delta_{jk} v_k^x = \frac{\partial z^h}{\partial x_k} v_k^x = v^h, \end{aligned}$$

which is the rule of *raising of the indices* for passing from covariant to contravariant components:

$$v^h = g^{hi} v_i.$$

Still applying the chain rule, by eq. (6.9) we get

$$\frac{\partial z^i}{\partial x^l} v_i = \frac{\partial z^i}{\partial x^l} \frac{\partial x_k}{\partial z^i} v_k^x = \frac{\partial x_k}{\partial x^l} v_k^x = \delta_{kl} v_k^x$$

i.e.

$$v_k^x = \frac{\partial z^i}{\partial x^k} v_i, \quad (6.12)$$

³The reader can easily see that, in practice, the chain rule allows to handle the derivatives as fractions.

⁴To prove that the contravariant components g^{pq} are the inverse of the covariant ones, g_{pq} is direct:

$$g^{pq} g_{pq} = \frac{\partial z^p}{\partial x_k} \frac{\partial z^q}{\partial x_k} \frac{\partial x_j}{\partial z^p} \frac{\partial x_j}{\partial z^q} = \delta_{jk} \delta_{jk} = 1.$$

which is the converse of eq. (6.9). In the same way we get the converse of eq. (6.10):

$$v_k^x = \frac{\partial x_k}{\partial z^i} v^i. \quad (6.13)$$

Let us now calculate the norm v of a vector \mathbf{v} ; starting from the Cartesian components and using the last two results,

$$v = \sqrt{\mathbf{v} \cdot \mathbf{v}} = \sqrt{v_k^x v_k^x} = \sqrt{\frac{\partial z^i}{\partial x^k} v_i \frac{\partial z^j}{\partial x^k} v_j} = \sqrt{\frac{\partial z^i}{\partial x^k} \frac{\partial z^j}{\partial x^k} v_i v_j} = \sqrt{g^{ij} v_i v_j},$$

or also

$$v = \sqrt{\mathbf{v} \cdot \mathbf{v}} = \sqrt{v_k^x v_k^x} = \sqrt{\frac{\partial x_k}{\partial z^i} v^i \frac{\partial x_k}{\partial z^j} v^j} = \sqrt{\frac{\partial x_k}{\partial z^i} \frac{\partial x_k}{\partial z^j} v^i v^j} = \sqrt{g_{ij} v^i v^j}$$

and even

$$v = \sqrt{\mathbf{v} \cdot \mathbf{v}} = \sqrt{v_k^x v_k^x} = \sqrt{\frac{\partial z^i}{\partial x_k} v_i \frac{\partial x_k}{\partial z^j} v^j} = \sqrt{\frac{\partial z^i}{\partial x_k} \frac{\partial x_k}{\partial z^j} v_i v^j} = \sqrt{\delta_j^i v_i v^j} = \sqrt{v_i v^i}.$$

Through eq. (6.13) and by the definition of the tangent vectors to the lines of curvilinear coordinates, eq. (6.5), for a vector \mathbf{v} we get

$$\mathbf{v} = v_i^x \mathbf{e}_i = v^k \frac{\partial x_i}{\partial z^k} \mathbf{e}_i = v^k \mathbf{g}_k.$$

We see hence that the contravariant components are actually the components of \mathbf{v} in the basis composed by the \mathbf{g}_k s, the tangents to the lines of curvilinear coordinates. In a similar manner, if we introduce the *dual basis* whose vectors \mathbf{g}^k are defined as

$$\mathbf{g}^k := \frac{\partial z^k}{\partial x_i} \mathbf{e}_i, \quad (6.14)$$

proceeding in the same way we obtain that

$$\mathbf{v} = v_i^x \mathbf{e}_i = v_k \frac{\partial z^k}{\partial x_i} \mathbf{e}_i = v_k \mathbf{g}^k,$$

i.e. the covariant components are actually the components of \mathbf{v} in the dual basis. Finally, for a vector we have, alternatively,

$$\mathbf{v} = v_i^x \mathbf{e}_i = v^k \mathbf{g}_k = v_k \mathbf{g}^k. \quad (6.15)$$

Just as for the \mathbf{g}_k s, we have

$$\mathbf{g}^h \cdot \mathbf{g}^k = \left(\frac{\partial z^h}{\partial x_i} \mathbf{e}_i \right) \cdot \left(\frac{\partial z^k}{\partial x_j} \mathbf{e}_j \right) = \frac{\partial z^h}{\partial x_i} \frac{\partial z^k}{\partial x_j} \delta_{ij} = \frac{\partial z^h}{\partial x_i} \frac{\partial z^k}{\partial x_i} = g^{hk};$$

moreover

$$\mathbf{g}^h \cdot \mathbf{g}_k = \left(\frac{\partial z^h}{\partial x_i} \mathbf{e}_i \right) \cdot \left(\frac{\partial x_j}{\partial z^k} \mathbf{e}_j \right) = \frac{\partial z^h}{\partial x_i} \frac{\partial x_j}{\partial z^k} \delta_{ij} = \frac{\partial z^h}{\partial x_i} \frac{\partial x_i}{\partial z^k} = \frac{\partial z^h}{\partial z^k} = \delta_k^h,$$

and by the symmetry of the scalar product

$$\delta_h^k := \mathbf{g}_h \cdot \mathbf{g}^k = \mathbf{g}^k \cdot \mathbf{g}_h = \delta_h^k.$$

The last equations defines the *orthogonality conditions* for the \mathbf{g} -vectors. Using these results and eq. (6.15) we have also

$$\begin{aligned} v^k &= \delta_h^k v^h = \mathbf{g}^k \cdot v^h \mathbf{g}_h = \mathbf{g}^k \cdot \mathbf{v} = \mathbf{g}^k \cdot v_h \mathbf{g}^h = g^{kh} v_h, \\ v_k &= \delta_k^h v_h = \mathbf{g}_k \cdot v_h \mathbf{g}^h = \mathbf{g}_k \cdot \mathbf{v} = \mathbf{g}_k \cdot v^h \mathbf{g}_h = g_{kh} v^h, \end{aligned}$$

so founding again the rules of raising and lowering of the indices.

What done for a vector, can be transposed, using a similar approach, to tensors. In particular, for a second-rank tensor \mathbf{L} we get

$$\begin{aligned} L^{ij} &= \frac{\partial z^i}{\partial x_h} \frac{\partial z^j}{\partial x_k} L_{hk}^x, \\ L_{ij} &= \frac{\partial x_h}{\partial z^i} \frac{\partial x_k}{\partial z^j} L_{hk}^x, \end{aligned} \tag{6.16}$$

for the contravariant and covariant components, respectively, while we can also introduce the *mixed components*

$$\begin{aligned} L^i_j &= \frac{\partial z^i}{\partial x_h} \frac{\partial x_k}{\partial z^j} L_{hk}^x, \\ L_i^j &= \frac{\partial x_h}{\partial z^i} \frac{\partial z^j}{\partial x_k} L_{hk}^x. \end{aligned} \tag{6.17}$$

Conversely,

$$\begin{aligned} L_{hk}^x &= \frac{\partial x_h}{\partial z^i} \frac{\partial x_k}{\partial z^j} L^{ij}, \\ L_{hk}^x &= \frac{\partial z^i}{\partial x_h} \frac{\partial z^j}{\partial x_k} L_{ij}, \\ L_{hk}^x &= \frac{\partial x_h}{\partial z^i} \frac{\partial z^j}{\partial x_k} L^i_j, \\ L_{hk}^x &= \frac{\partial z^i}{\partial x_h} \frac{\partial x_k}{\partial z^j} L_i^j. \end{aligned} \tag{6.18}$$

Also for \mathbf{L} , the rule of lowering or raising the indices is valid:

$$L^{ij} = g^{ih} g^{jk} L_{hk}, \quad L_{ij} = g_{ih} g_{jk} L^{hk}.$$

From eq. (6.18) and by the same definitions of g_{ij} , eq.(6.3), and g^{ij} , eq. (6.11), we get

$$\mathbf{L} = L_{ij}^x \mathbf{e}_i \otimes \mathbf{e}_j = \frac{\partial x_i}{\partial z^h} \frac{\partial x_j}{\partial z^k} L^{hk} \mathbf{e}_i \otimes \mathbf{e}_j = L^{hk} \mathbf{g}_h \otimes \mathbf{g}_k$$

and

$$\mathbf{L} = L_{ij}^x \mathbf{e}_i \otimes \mathbf{e}_j = \frac{\partial z^h}{\partial x_i} \frac{\partial z^k}{\partial x_j} L_{hk} \mathbf{e}_i \otimes \mathbf{e}_j = L_{hk} \mathbf{g}^h \otimes \mathbf{g}^k.$$

In the same manner, the tensor mixed components are also found:

$$\mathbf{L} = L_{ij}^x \mathbf{e}_i \otimes \mathbf{e}_j = \frac{\partial x_i}{\partial z^h} \frac{\partial z^k}{\partial x_j} L_{ij}^x \mathbf{e}_i \otimes \mathbf{e}_j = L_{ij}^x L_{ij}^k \mathbf{e}_i \otimes \mathbf{e}_j = L_{ij}^k \mathbf{g}_i \otimes \mathbf{g}_j$$

and

$$\mathbf{L} = L_{ij}^x \mathbf{e}_i \otimes \mathbf{e}_j = \frac{\partial z^k}{\partial x_j} \frac{\partial x_i}{\partial z^h} L_{ij}^x \mathbf{e}_i \otimes \mathbf{e}_j = L_{ij}^x L_{ij}^k \mathbf{e}_i \otimes \mathbf{e}_j = L_{ij}^k \mathbf{g}_i \otimes \mathbf{g}_j$$

We see hence that a second-rank tensor can be given with four different combinations of coordinates; even more complex is the case of higher order tensors, that will not be treated here.

Still by eqs.(6.3) and (6.11) and applying the chain rule to $\delta_j^i = \frac{\partial z^i}{\partial z^j}$, we get

$$\begin{aligned} g_{ij} &= \frac{\partial x_k}{\partial z^i} \frac{\partial x_k}{\partial z^j} = \frac{\partial x_h}{\partial z^i} \frac{\partial x_k}{\partial z^j} \delta_{hk}, \\ g^{ij} &= \frac{\partial z^i}{\partial x_k} \frac{\partial z^j}{\partial x_k} = \frac{\partial z^i}{\partial x_h} \frac{\partial z^j}{\partial x_k} \delta_{hk}, \\ \delta_j^i &= \frac{\partial z^i}{\partial x_h} \frac{\partial x_k}{\partial z^j} \delta_{hk}, \\ \delta_i^j &= \frac{\partial x_h}{\partial z^i} \frac{\partial z^j}{\partial x_k} \delta_{hk}. \end{aligned} \tag{6.19}$$

So, applying eq. (6.18) to the identity tensor we get

$$\mathbf{I} = \delta_{ij} \mathbf{e}_i \otimes \mathbf{e}_j = \frac{\partial x_i}{\partial z^h} \frac{\partial x_j}{\partial z^k} I^{hk} \mathbf{e}_i \otimes \mathbf{e}_j = I^{hk} \mathbf{g}_h \otimes \mathbf{g}_k,$$

but, by eqs. (6.16) and (6.19),

$$I^{hk} = \frac{\partial z^h}{\partial x_i} \frac{\partial z^k}{\partial x_j} \delta_{ij} = g^{hk}$$

so finally

$$\mathbf{I} = g^{hk} \mathbf{g}_h \otimes \mathbf{g}_k.$$

Proceeding in the same manner, we get also

$$\mathbf{I} = g_{hk} \mathbf{g}^h \otimes \mathbf{g}^k = \delta_{ij}^h \mathbf{g}_i \otimes \mathbf{g}^j = \delta_{ij}^k \mathbf{g}^i \otimes \mathbf{g}_j.$$

We see hence that the g_{hk} s represent \mathbf{I} in covariant coordinates, the g^{hk} s in the contravariant ones and the δ_{ij}^k s and δ_{ij}^h s in mixed coordinates.

6.4 Spatial derivatives of fields in curvilinear coordinates

Let φ a spatial⁵ scalar field, $\varphi : \mathcal{E} \rightarrow \mathbb{R}$. Generally speaking,

$$\varphi = \varphi(z^j(x_i)),$$

⁵The term *spatial* here refers to differentiation with respect to spatial coordinates, that can be Cartesian or curvilinear.

or also

$$\varphi = \varphi(x_j(z^k)),$$

where the x_j s, z^k s are respectively Cartesian and curvilinear coordinates, related as in eq. (6.1). By the chain rule

$$\frac{\partial \varphi}{\partial x_j} = \frac{\partial \varphi}{\partial z^k} \frac{\partial z^k}{\partial x_j} \quad (6.20)$$

and inversely

$$\frac{\partial \varphi}{\partial z^k} = \frac{\partial \varphi}{\partial x_j} \frac{\partial x_j}{\partial z^k}.$$

We remark that the last quantity transforms like the components of a covariant vector, cf. eq.(6.9).

The *gradient* of φ is the vector that in the Cartesian basis is defined by

$$\nabla \varphi = \frac{\partial \varphi}{\partial x_j} \mathbf{e}_j;$$

so, by eqs. (6.14) and (6.20) we get that in the dual basis

$$\nabla \varphi = \frac{\partial \varphi}{\partial z^k} \frac{\partial z^k}{\partial x_j} \mathbf{e}_j = \frac{\partial \varphi}{\partial z^k} \mathbf{g}^k.$$

We see hence that in curvilinear coordinates the *nabla operator* is defined by

$$\nabla(\cdot) = \frac{\partial \cdot}{\partial z^k} \mathbf{g}^k. \quad (6.21)$$

The contravariant components of the gradient can be obtained by the covariant ones upon multiplication by the components of the inverse (contravariant) metric tensor, eq. (6.11):

$$g^{hk} \frac{\partial \varphi}{\partial z^k} = \frac{\partial z^h}{\partial x_i} \frac{\partial z^k}{\partial x_i} \frac{\partial \varphi}{\partial x_j} \frac{\partial x_j}{\partial z^k} = \delta_{ij} \frac{\partial \varphi}{\partial x_j} \frac{\partial z^h}{\partial x_i} = \frac{\partial \varphi}{\partial x_j} \frac{\partial z^h}{\partial x_j} \rightarrow \nabla \varphi = \frac{\partial \varphi}{\partial x_j} \frac{\partial z^h}{\partial x_j} \mathbf{g}^h.$$

Let us now consider a vector field $\mathbf{v} : \mathcal{E} \rightarrow \mathcal{V}$; we want to calculate the spatial derivative of its Cartesian components. By the chain rule and eq. (6.13) we get

$$\begin{aligned} \frac{\partial v_i^x}{\partial x_j} &= \frac{\partial v_i^x}{\partial z^k} \frac{\partial z^k}{\partial x_j} = \frac{\partial z^k}{\partial x_j} \frac{\partial}{\partial z^k} \left(\frac{\partial x_i}{\partial z^h} v^h \right) = \frac{\partial z^k}{\partial x_j} \left(\frac{\partial x_i}{\partial z^h} \frac{\partial v^h}{\partial z^k} + \frac{\partial^2 x_i}{\partial z^k \partial z^l} v^l \right) \\ &= \frac{\partial z^k}{\partial x_j} \frac{\partial x_i}{\partial z^h} \left(\frac{\partial v^h}{\partial z^k} + \frac{\partial z^h}{\partial x_m} \frac{\partial^2 x_m}{\partial z^k \partial z^l} v^l \right), \end{aligned}$$

whence

$$\frac{\partial z^h}{\partial x_i} \frac{\partial x_j}{\partial z^k} \frac{\partial v_i^x}{\partial x_j} = \frac{\partial v^h}{\partial z^k} + \frac{\partial z^h}{\partial x_m} \frac{\partial^2 x_m}{\partial z^k \partial z^l} v^l. \quad (6.22)$$

Comparing this result with eq. (6.17)₁ we see that the first member actually corresponds to the components of a mixed tensor field which is the *gradient of the vector field* \mathbf{v} , that we write as

$$v^h{}_{;k} = \frac{\partial v^h}{\partial z^k} + \Gamma_{kl}^h v^l, \quad (6.23)$$

where the

$$\Gamma_{kl}^h = \frac{\partial z^h}{\partial x_m} \frac{\partial^2 x_m}{\partial z^k \partial z^l} \quad (6.24)$$

are the *Christoffel symbols*. We immediately see that $\Gamma_{kl}^h = \Gamma_{lk}^h$. The quantity $v^h{}_{;k}$ is the *covariant derivative of the contravariant components* v^h . It can be proved that the Christoffel symbols can be written also as

$$\Gamma_{kl}^h = \frac{1}{2} g^{hm} \left(\frac{\partial g_{mk}}{\partial z^l} + \frac{\partial g_{ml}}{\partial z^k} - \frac{\partial g_{kl}}{\partial z^m} \right). \quad (6.25)$$

Proceeding in the same way for the covariant components of \mathbf{v} , but now using eqs. (6.12) and (6.17)₁, we get

$$v_{h;k} = \frac{\partial v_h}{\partial z^k} - \Gamma_{kh}^l v_l,$$

which is the *covariant derivative of the covariant components* v_h .

Using eqs. (6.22) and (6.23), we conclude that

$$\operatorname{div} \mathbf{v} := \frac{\partial v_i^x}{\partial x_i} = v^h{}_{;h}.$$

Then, applying the operator divergence so defined to the gradient of the scalar field φ we obtain, in arbitrary coordinates z , the Laplacian $\Delta\varphi$ as

$$\Delta\varphi = \left(g^{hk} \frac{\partial \varphi}{\partial z^k} \right)_{;h} = \frac{\partial}{\partial z^h} \left(g^{hk} \frac{\partial \varphi}{\partial z^k} \right) + \Gamma_{hj}^h g^{jk} \frac{\partial \varphi}{\partial z^k}.$$

Using the definition of the nabla operator in curvilinear coordinates, eq. (6.21), jointly to the fact that, cf. Sect. 5.5,

$$\operatorname{div} \nabla f = \nabla \cdot \nabla f,$$

we get the the following representation of the Laplace operator in curvilinear coordinates:

$$\begin{aligned} \Delta(\cdot) &= \nabla \cdot \nabla(\cdot) = \left(\frac{\partial}{\partial z^k} \left(\frac{\partial(\cdot)}{\partial z^h} \mathbf{g}^h \right) \right) \cdot \mathbf{g}^k = \frac{\partial^2(\cdot)}{\partial z^k \partial z^h} \mathbf{g}^h \cdot \mathbf{g}^k + \frac{\partial \mathbf{g}^h}{\partial z^k} \frac{\partial(\cdot)}{\partial z^h} \cdot \mathbf{g}^k \\ &= \frac{\partial^2(\cdot)}{\partial z^k \partial z^h} g^{hk} + \frac{\partial \mathbf{g}^h}{\partial z^k} \cdot \mathbf{g}^k \frac{\partial(\cdot)}{\partial z^h}. \end{aligned}$$

Let us now calculate the spatial derivatives of the components of a 2^{nd} -rank tensor \mathbf{L} : by eqs. (6.18)₁ and (6.24) we get

$$\frac{\partial L_{ij}^x}{\partial x_k} = \frac{\partial z^h}{\partial x_k} \frac{\partial}{\partial z^h} \left(\frac{\partial x_i}{\partial z^n} \frac{\partial x_j}{\partial z^p} L^{np} \right) = \frac{\partial z^h}{\partial x_k} \frac{\partial x_i}{\partial z^n} \frac{\partial x_j}{\partial z^p} \left(\frac{\partial L^{np}}{\partial z^h} + \Gamma_{hr}^n L^{rp} + \Gamma_{hr}^p L^{nr} \right),$$

which implies that

$$\frac{\partial L^{np}}{\partial z^h} + \Gamma_{hr}^n L^{rp} + \Gamma_{hr}^p L^{nr} = \frac{\partial x_k}{\partial z^h} \frac{\partial z^n}{\partial x_i} \frac{\partial z^p}{\partial x_j} \frac{\partial L_{ij}^x}{\partial x_k}. \quad (6.26)$$

So, eq. (6.16), we can conclude that the expression

$$L^{np}{}_{;h} = \frac{\partial L^{np}}{\partial z^h} + \Gamma_{hr}^n L^{rp} + \Gamma_{hr}^p L^{nr} \quad (6.27)$$

represents the covariant derivative of the contravariant components of the second-rank tensor \mathbf{L} . In a similar manner, this time by eq. (6.18)₂, we obtain the covariant derivatives of the covariant components of \mathbf{L} :

$$\frac{\partial L_{np}}{\partial z^h} - \Gamma_{nh}^r L_{rp} - \Gamma_{ph}^r L_{nr} = \frac{\partial x_k}{\partial z^h} \frac{\partial x_i}{\partial z^n} \frac{\partial x_j}{\partial z^p} \frac{\partial L_{ij}^x}{\partial x_k},$$

i.e.

$$L_{np;h} = \frac{\partial L_{np}}{\partial z^h} - \Gamma_{ph}^r L_{nr} - \Gamma_{nh}^r L_{pr}. \quad (6.28)$$

The same procedure with eqs. (6.18)_{3,4} gives the covariant derivatives of the mixed components of \mathbf{L} :

$$\begin{aligned} L^n{}_{p;h} &= \frac{\partial L^n{}_p}{\partial z^h} + \Gamma_{hr}^n L^r{}_p - \Gamma_{ph}^r L^n{}_r, \\ L_p{}^n{}_{;h} &= \frac{\partial L_p{}^n}{\partial z^h} - \Gamma_{ph}^r L_r{}^n + \Gamma_{hr}^n L_p{}^r. \end{aligned} \quad (6.29)$$

Equations (6.27), (6.28) and (6.29) represents the different forms of the components of a third-rank tensor $\nabla \mathbf{L}$, the *gradient of \mathbf{L}* .

If in eqs. (6.26) and (6.27) we put $p = h$, we get

$$L^{nh}{}_{;h} = \frac{\partial L^{nh}}{\partial z^h} + \Gamma_{hr}^n L^{rh} + \Gamma_{hr}^h L^{nr} = \frac{\partial x_k}{\partial z^h} \frac{\partial z^n}{\partial x_i} \frac{\partial z^h}{\partial x_j} \frac{\partial L_{ij}^x}{\partial x_k} = \delta_{kj} \frac{\partial z^n}{\partial x_i} \frac{\partial L_{ij}^x}{\partial x_k} = \frac{\partial z^n}{\partial x_i} \frac{\partial L_{ij}^x}{\partial x_j},$$

which are the components of the contravariant vector field $\text{div} \mathbf{L}$, the *divergence of \mathbf{L}* .

6.5 Exercises

1. Write \mathbf{g} and ds for cylindrical coordinates.
2. Write \mathbf{g} and ds for spherical coordinates.
3. Find the length of a cylindrical helix on a cylinder of radius R between the angles θ and $\theta + 2\pi$.
4. A curve is traced in a quarter of circle of radius R , see Fig. 6.6; when the quarter of circle is rolled into a cone, the curve appears as indicated in the figure, after having described, in the plane, a complete circle. Determine the length ℓ of the curve, first using the polar coordinates in the plane of the quarter of circle, then the cylindrical ones for case of the curve on the cone.

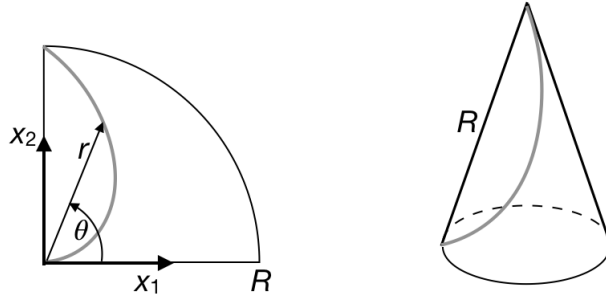

Figure 6.6: Curve in a plane and on a cone.

5. Calculate \mathbf{g} for a planar system of coordinates composed by two axes z^1 and z^2 inclined respectively of α_1 and α_2 on the axis x_1 .
6. Calculate the \mathbf{g}_i s for a system of spherical coordinates.
7. In the plane, elliptical coordinates are defined by the relations

$$x_1 = c \cosh z^1 \cos z^2, \quad x_2 = c \sinh z^1 \sin z^2, \quad z^1 \in (0, \infty), \quad z^2 \in [0, 2\pi);$$

show that the lines $z^1 = \text{const.}$, $z^2 = \text{const.}$ are confocal ellipses and hyperbolae, determine the axes of the ellipses in terms of the parameter c , discuss the limit case of ellipses that degenerate into a crack and determine its length. Finally, find \mathbf{g} , \mathbf{g}_1 , \mathbf{g}_2 .

8. Determine the co- and contra-variant components of a tensor \mathbf{L} in cylindrical coordinates.
9. Determine the co- and contra-variant components of a tensor \mathbf{L} in spherical coordinates.
10. For the case of exercise 5, calculate the vectors \mathbf{g}_k and \mathbf{g}^k , design these vectors and check the orthogonality conditions $\mathbf{g}^h \cdot \mathbf{g}_k = \delta_k^h$.
11. Show that

$$\text{tr}\mathbf{L} = L_{ii}^x = g^{ij}L_{ij} = g_{ij}L^{ij} = L^i_i = L_j^j.$$

12. Prove eq. (6.25).
13. Prove the *Lemme of Ricci*:

$$\frac{\partial g_{jk}}{\partial z^h} = \Gamma_{jh}^i g_{ik} + \Gamma_{kh}^i g_{ji}.$$

14. Using eq. (6.25) find the Christoffel symbols for the cylindrical, spherical and elliptical (in the plane) coordinates.
15. Write the Laplace operator in cylindrical and spherical coordinates.
16. Prove that

$$g^{np}{}_{;h} = g_{np;h} = 0.$$

Chapter 7

Surfaces in \mathcal{E}

7.1 Surfaces in \mathcal{E} , coordinate lines, tangent planes

A function $\mathbf{f}(u, v) : \Omega \subset \mathbb{R}^2 \rightarrow \mathcal{E}$ of class $\geq C^1$ and such that its Jacobian

$$J = \begin{bmatrix} \frac{\partial f_1}{\partial u} & \frac{\partial f_1}{\partial v} \\ \frac{\partial f_2}{\partial u} & \frac{\partial f_2}{\partial v} \\ \frac{\partial f_3}{\partial u} & \frac{\partial f_3}{\partial v} \end{bmatrix}$$

has maximum rank ($\text{rank}[J]=2$) defines a *surface in \mathcal{E}* , see Fig. 7.1. We say also that \mathbf{f} is an *immersion* of Ω into \mathcal{E} and that the subset $\Sigma \subset \mathcal{E}$ image of \mathbf{f} is the *support* or *trace* of the surface \mathbf{f} .

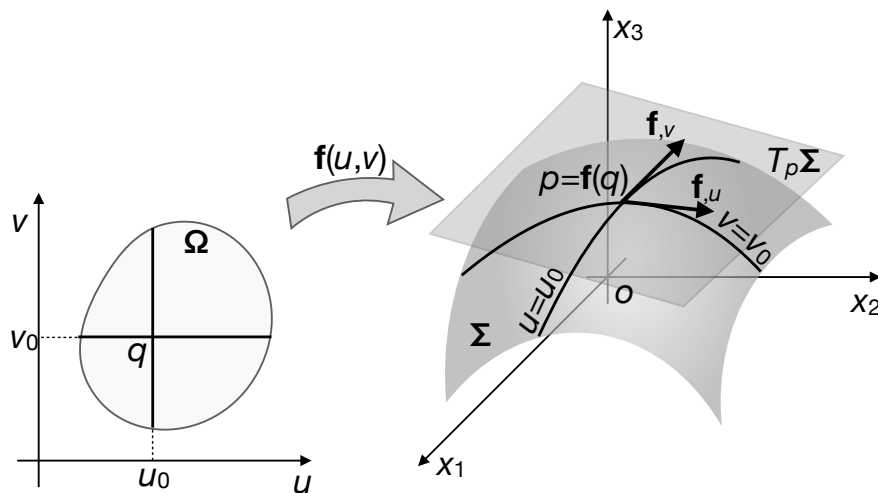

Figure 7.1: General scheme of a surface and of the tangent space at a point p .

We will also indicate derivatives with respect to the variables u, v by, e.g., $\frac{\partial \mathbf{f}}{\partial u} = \mathbf{f}_{,u}$ etc.

The condition on the rank of J is equivalent to impose that

$$\mathbf{f}_{,u}(u, v) \times \mathbf{f}_{,v}(u, v) \neq \mathbf{o} \quad \forall (u, v) \in \Omega. \quad (7.1)$$

The *normal to the surface* \mathbf{f} is the vector $\mathbf{N} \in \mathcal{S}$ defined as

$$\mathbf{N} := \frac{\mathbf{f}_{,u} \times \mathbf{f}_{,v}}{|\mathbf{f}_{,u} \times \mathbf{f}_{,v}|}. \quad (7.2)$$

A *regular point of* Σ is a point where \mathbf{N} is defined; if \mathbf{N} is defined $\forall p \in \Sigma$ then the surface is said to be *regular*.

A function $\gamma(t) : G \subset \mathbb{R} \rightarrow \Omega$ whose parametric equation is $\gamma(t) = (u(t), v(t))$ describes a curve in Ω whose image, through \mathbf{f} , is a curve

$$\hat{\gamma}(t) = \mathbf{f}(u(t), v(t)) : G \subset \mathbb{R} \rightarrow \Sigma \subset \mathcal{E}.$$

As a special case of curve in Ω , let us consider the curves of the type $v = v_0$ or $u = u_0$, with u_0, v_0 some constants. Then, their image through \mathbf{f} are two curves $\mathbf{f}(u, v_0), \mathbf{f}(u_0, v)$ on Σ called *coordinate lines*, see Fig. 7.1. The *tangent vectors to the coordinate lines* are respectively the vectors $\mathbf{f}_{,u}(u, v_0)$ and $\mathbf{f}_{,v}(u_0, v)$, while the tangent to a curve $\hat{\gamma}(t) = \mathbf{f}(u(t), v(t))$ is the vector

$$\hat{\gamma}'(t) = \mathbf{f}_{,u} \frac{du}{dt} + \mathbf{f}_{,v} \frac{dv}{dt}, \quad (7.3)$$

i.e. the tangent vector to any curve on Σ is a linear combination of the tangent vectors to the coordinate lines. To remark that the tangent vectors $\mathbf{f}_{,u}(u, v_0)$ and $\mathbf{f}_{,v}(u_0, v)$ are necessarily non null and linear independent as consequence of the assumption on the rank of J , and hence of the existence of \mathbf{N} , i.e. of the regularity of Σ . They determine a plane that contains the tangents to all the curves on Σ passing by $p = \mathbf{f}(u_0, v_0)$ and form a basis on this plane, called the *natural basis*. Such a plane is the *tangent plane to Σ in p* and is indicated by $T_p\Sigma$; this plane is actually the space spanned by $\mathbf{f}_{,u}(u, v_0)$ and $\mathbf{f}_{,v}(u_0, v)$ and is also called the *tangent vector space*.

Let us consider two open subsets $\Omega_1, \Omega_2 \subset \mathbb{R}^2$; a *diffeomorphism*¹ of class C^k between Ω_1 and Ω_2 is a bijective map $\vartheta : \Omega_1 \rightarrow \Omega_2$ of class C^k with also its inverse of class C^k ; the diffeomorphism is *smooth* if $k = \infty$.

Let Ω_1, Ω_2 be two open subsets of \mathbb{R}^2 , $\mathbf{f} : \Omega_2 \rightarrow \mathcal{E}$ a surface and $\vartheta : \Omega_1 \rightarrow \Omega_2$ a smooth diffeomorphism. Then the surface $\mathbf{F} = \mathbf{f} \circ \vartheta : \Omega_1 \rightarrow \mathcal{E}$ is a *change of parameterization* for \mathbf{f} . In practice, the function defining the surface changes, but not Σ , its trace in \mathcal{E} . Let (U, V) be the coordinates in Ω_1 and (u, v) in Ω_2 ; then, by the chain rule,

$$\begin{aligned} \mathbf{F}_{,U} &= \mathbf{f}_{,u} \frac{\partial u}{\partial U} + \mathbf{f}_{,v} \frac{\partial v}{\partial U}, \\ \mathbf{F}_{,V} &= \mathbf{f}_{,u} \frac{\partial u}{\partial V} + \mathbf{f}_{,v} \frac{\partial v}{\partial V}, \end{aligned}$$

¹The definition of diffeomorphism, of course, can be given for subsets of $\mathbb{R}^n, n \geq 1$; here, we bound the definition to the case of interest.

or, denoting by J_ϑ the Jacobian of ϑ ,

$$\begin{Bmatrix} \mathbf{F}_{,U} \\ \mathbf{F}_{,V} \end{Bmatrix} = [J_\vartheta]^\top \begin{Bmatrix} \mathbf{f}_{,u} \\ \mathbf{f}_{,v} \end{Bmatrix},$$

whence

$$\mathbf{F}_{,U} \times \mathbf{F}_{,V} = \det[J_\vartheta] \mathbf{f}_{,u} \times \mathbf{f}_{,v}.$$

This result shows that the regularity of the surface, condition (7.1), the tangent plane and the tangent space vector *do not depend upon the parameterization of Σ* . From the last equation, we get also

$$\mathbf{N}(U, V) = \text{sgn}(\det[J_\vartheta]) \mathbf{N}(u, v);$$

we say that the change of parameterization *preserves the orientation if $\det[J_\vartheta] > 0$* , and that it *inverses the parameterization* in the opposite case.

7.2 Surfaces of revolution

A *surface of revolution* is a surface whose trace is obtained letting rotate a plane curve, say γ , around an axis, say x_3 . To be more specific, and without loss of generality, let $\gamma : G \subset \mathbb{R} \rightarrow \mathbb{R}^2$ be a regular curve of the plane $x_2 = 0$, whose parametric equation is

$$\gamma(u) : \begin{cases} x_1 = \varphi(u), \\ x_3 = \psi(u), \end{cases} \quad \varphi(u) > 0 \quad \forall u \in G. \quad (7.4)$$

Then, the subset $\Sigma_\gamma \subset \mathcal{E}$ defined by

$$\Sigma_\gamma := \{(x_1, x_2, x_3) \in \mathcal{E} \mid x_1^2 + x_2^2 = \varphi^2(u), x_3 = \psi(u), u \in G\}$$

is the trace of a surface of revolution of the curve $\gamma(u)$ around the axis x_3 . A general parameterization of such a surface is

$$\mathbf{f}(u, v) : G \times (-\pi, \pi] \rightarrow \mathcal{E} \quad \begin{cases} x_1 = \varphi(u) \cos v, \\ x_2 = \varphi(u) \sin v, \\ x_3 = \psi(u). \end{cases} \quad (7.5)$$

It is readily checked that this parameterization actually defines a regular surface:

$$\mathbf{f}_{,u} = \begin{Bmatrix} \varphi'(u) \cos v \\ \varphi'(u) \sin v \\ \psi'(u) \end{Bmatrix}, \quad \mathbf{f}_{,v} = \begin{Bmatrix} -\varphi(u) \sin v \\ \varphi(u) \cos v \\ 0 \end{Bmatrix} \rightarrow \mathbf{f}_{,u} \times \mathbf{f}_{,v} = \begin{Bmatrix} -\varphi(u) \psi'(u) \cos v \\ -\varphi(u) \psi'(u) \sin v \\ \varphi(u) \varphi'(u) \end{Bmatrix}$$

so that

$$|\mathbf{f}_{,u} \times \mathbf{f}_{,v}| = \varphi^2(u) (\varphi'^2(u) + \psi'^2(u)) \neq 0 \quad \forall u \in G$$

for being $\gamma(u)$ a regular curve, i.e. with $\gamma'(u) \neq \mathbf{o} \quad \forall u \in G$. A *meridian* is a curve in \mathcal{E} intersection of the trace of \mathbf{f} , Σ_γ , with a plane containing the axis x_3 ; the equation of a meridian is obtained fixing the value of v , say $v = v_0$:

$$\begin{cases} x_1 = \varphi(u) \cos v_0, \\ x_2 = \varphi(u) \sin v_0, \\ x_3 = \psi(u). \end{cases}$$

A *parallel* is a curve in \mathcal{E} intersection of Σ_γ with a plane orthogonal to x_3 ; the equation of a parallel, which is a circle with center on the axis x_3 , is obtained fixing the value of u , say $u = u_0$:

$$\begin{cases} x_1 = \varphi(u_0) \cos v, \\ x_2 = \varphi(u_0) \sin v, \\ x_3 = \psi(u_0), \end{cases}$$

or also

$$\begin{cases} x_1^2 + x_2^2 = \varphi(u_0)^2, \\ x_3 = \psi(u_0); \end{cases}$$

the radius of the circle is $\varphi(u_0)$.

A *loxodrome* or *rhumb line* is a curve on Σ_γ crossing all the meridians at the same angle.

Some important examples of surfaces of revolution are:

- the *sphere*:

$$\mathbf{f}(u, v) : \left[-\frac{\pi}{2}, \frac{\pi}{2}\right] \times (-\pi, \pi] \rightarrow \mathcal{E} \mid \begin{cases} x_1 = \cos u \cos v, \\ x_2 = \cos u \sin v, \\ x_3 = \sin v; \end{cases}$$

- the *catenoid*:

$$\mathbf{f}(u, v) : [-a, a] \times (-\pi, \pi] \rightarrow \mathcal{E} \mid \begin{cases} x_1 = \cosh u \cos v, \\ x_2 = \cosh u \sin v, \\ x_3 = u; \end{cases}$$

- the *pseudo-sphere*:

$$\mathbf{f}(u, v) : [0, a] \times (-\pi, \pi] \rightarrow \mathcal{E} \mid \begin{cases} x_1 = \sin u \cos v, \\ x_2 = \sin u \sin v, \\ x_3 = \cos u + \ln\left(\tan \frac{u}{2}\right); \end{cases} \quad (7.6)$$

- the *hyperbolic hyperboloid*:

$$\mathbf{f}(u, v) : [-a, a] \times (-\pi, \pi] \rightarrow \mathcal{E} \mid \begin{cases} x_1 = \cos u - v \sin u, \\ x_2 = \sin u + v \cos u, \\ x_3 = v. \end{cases}$$

7.3 Ruled surfaces

A *ruled surface* (also named a *scroll*) is a surface with the property that through every one of its points there is a straight line that lies on the surface. A ruled surface can be seen as the set of points swept by a moving straight line. We say that a surface is *doubly*

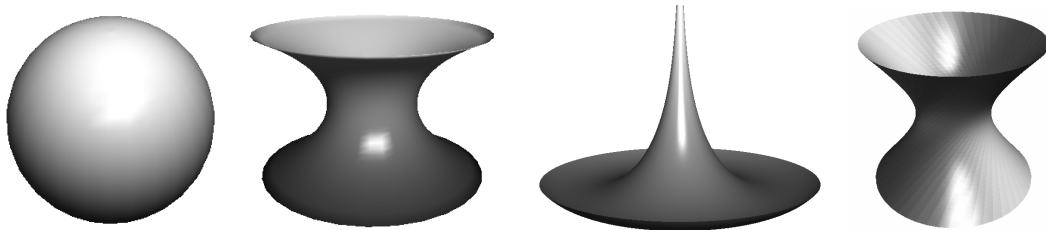

Figure 7.2: Surfaces of revolution. From the left: sphere, catenoid, pseudo-sphere, hyperbolic hyperboloid.

ruled if through every one of its points there are two distinct straight lines that lie on the surface.

Any ruled surface can be represented by a parameterization of the form

$$\mathbf{f}(u, v) = \boldsymbol{\gamma}(u) + v\boldsymbol{\lambda}(u), \quad (7.7)$$

where $\boldsymbol{\gamma}(u)$ is a regular smooth curve, the *directrix*, and $\boldsymbol{\lambda}(u)$ is a smooth curve. Fixing $u = u_0$ gives a *generator line* $\mathbf{f}(u_0, v)$ of the surface; the vectors $\boldsymbol{\lambda}(u) \neq \mathbf{0}$ describe the directions of the generators. Some important examples of ruled surfaces are:

- *cones*: for these surfaces, all the straight lines pass through a point, the *apex* of the cone, choosing the apex as the origin, then it must be $\boldsymbol{\lambda}(u) = k\boldsymbol{\gamma}(u)$, $k \in \mathbb{R} \rightarrow$

$$\mathbf{f}(u, v) = v\boldsymbol{\gamma}(u);$$

- *cylinders*: a ruled surface is a cylinder $\iff \boldsymbol{\lambda}(u) = \text{const}$. In this case, it is always possible to choose $\boldsymbol{\lambda}(u) \in \mathcal{S}$ and $\boldsymbol{\gamma}(u)$ a planar curve lying in a plane orthogonal to $\boldsymbol{\lambda}(u)$ (it is sufficient to choose the curve $\boldsymbol{\gamma}^*(u) = (\mathbf{I} - \boldsymbol{\lambda}(u) \otimes \boldsymbol{\lambda}(u))\boldsymbol{\gamma}(u)$);
- *helicoids*: a surface generated by rotating and simultaneously displacing a curve, the *profile curve*, along an axis is a helicoid. Any point of the profile curve is the starting point of a circular helix. Generally speaking, we get a helicoid if

$$\boldsymbol{\gamma}(u) = (0, 0, \varphi(u)), \quad \boldsymbol{\lambda}(u) = (\cos u, \sin u, 0), \quad \varphi(u) : \mathbb{R} \rightarrow \mathbb{R}.$$

- *Möbius strip*: it is a ruled surface with

$$\boldsymbol{\gamma}(u) = (\cos 2u, \sin 2u, 0), \quad \boldsymbol{\lambda}(u) = (\cos u \cos 2u, \cos u \sin 2u, \sin u).$$

7.4 First fundamental form of a surface

We call *first fundamental form of a surface*, denoted by $I(\cdot, \cdot)$, the restriction of the scalar product to the tangent vector space $T_p\Sigma$. We recall that a scalar product is a positive definite symmetric form. Let us consider two vectors $\mathbf{w}_1 = a_1\mathbf{f}_{,u} + b_1\mathbf{f}_{,v}$, $\mathbf{w}_2 = a_2\mathbf{f}_{,u} + b_2\mathbf{f}_{,v} \in T_p\Sigma$; then

$$I(\mathbf{w}_1, \mathbf{w}_2) = \mathbf{w}_1 \cdot \mathbf{w}_2 = a_1a_2\mathbf{f}_{,u}^2 + (a_1b_2 + a_2b_1)\mathbf{f}_{,u} \cdot \mathbf{f}_{,v} + b_1b_2\mathbf{f}_{,v}^2$$

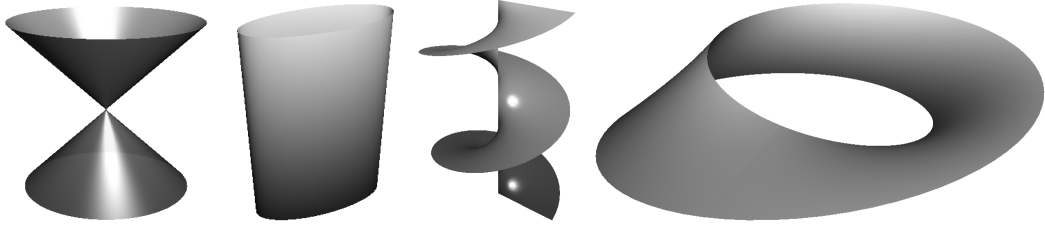

Figure 7.3: Ruled surfaces. From the left: elliptical cone, elliptical cylinder, helicoid, Möbius strip.

is the first form of $\mathbf{f}(u, v)$; if $\mathbf{w}_1 = \mathbf{w}_2 = \mathbf{w} = a\mathbf{f}_{,u} + b\mathbf{f}_{,v}$, then

$$I(\mathbf{w}) = \mathbf{w}^2 = a^2\mathbf{f}_{,u}^2 + 2ab\mathbf{f}_{,u} \cdot \mathbf{f}_{,v} + b^2\mathbf{f}_{,v}^2$$

is a positive form $\forall \mathbf{w} \in T_p\Sigma$. We can rewrite $I(\cdot, \cdot)$ in the form

$$I(\mathbf{w}_1, \mathbf{w}_2) = \mathbf{w}_1 \cdot \mathbf{g} \mathbf{w}_2,$$

where²

$$\mathbf{g} = \begin{bmatrix} \mathbf{f}_{,u} \cdot \mathbf{f}_{,u} & \mathbf{f}_{,u} \cdot \mathbf{f}_{,v} \\ \mathbf{f}_{,v} \cdot \mathbf{f}_{,u} & \mathbf{f}_{,v} \cdot \mathbf{f}_{,v} \end{bmatrix}$$

is actually the metric tensor \mathbf{g} of Σ , cf. eq. (6.6). In fact, $\mathbf{f}_{,u}$ and $\mathbf{f}_{,v}$ are the tangent vectors to the coordinate lines on Σ , i.e. they coincide with the vectors \mathbf{g}_k .

Through $I(\cdot, \cdot)$ we can calculate some important quantities regarding the geometry of Σ :

- metric on Σ : $\forall ds \in \Sigma$,

$$ds^2 = ds \cdot ds = I(ds);$$

so, if

$$ds = \mathbf{f}_{,u}du + \mathbf{f}_{,v}dv$$

then

$$ds^2 = \mathbf{f}_{,u}^2 du^2 + 2\mathbf{f}_{,u} \cdot \mathbf{f}_{,v} du dv + \mathbf{f}_{,v}^2 dv^2; \quad (7.8)$$

- length ℓ of a curve $\gamma : [t_1, t_2] \subset \mathbb{R} \rightarrow \Sigma$: we know, eq. (4.4), that the length of a curve is the integral of the tangent vector:

$$\ell = \int_{t_1}^{t_2} |\gamma'(t)| dt = \int_{t_1}^{t_2} \sqrt{\gamma'(t) \cdot \gamma'(t)} dt$$

²Often, in texts on differential geometry, tensor \mathbf{g} is indicated as

$$\mathbf{g} = \begin{bmatrix} E & F \\ F & G \end{bmatrix},$$

where $E := \mathbf{f}_{,u} \cdot \mathbf{f}_{,u}$, $F := \mathbf{f}_{,u} \cdot \mathbf{f}_{,v}$, $G := \mathbf{f}_{,v} \cdot \mathbf{f}_{,v}$.

and hence, see eq. (7.3), if we call $\mathbf{w} = (u', v')$ the tangent vector to γ , expressed by its components in the natural basis,

$$\begin{aligned} \ell &= \int_{t_1}^{t_2} \sqrt{u'^2 \mathbf{f}_{,u}^2 + 2u'v' \mathbf{f}_{,u} \cdot \mathbf{f}_{,v} + v'^2 \mathbf{f}_{,v}^2} dt = \int_{t_1}^{t_2} \sqrt{(u', v') \cdot \mathbf{g}(u', v')} dt \\ &= \int_{t_1}^{t_2} \sqrt{I(\mathbf{w})} dt; \end{aligned} \quad (7.9)$$

- angle θ formed by two vectors $\mathbf{w}_1, \mathbf{w}_2 \in T_p \Sigma$:

$$\cos \theta = \frac{\mathbf{w}_1 \cdot \mathbf{w}_2}{|\mathbf{w}_1| |\mathbf{w}_2|} = \frac{I(\mathbf{w}_1, \mathbf{w}_2)}{\sqrt{I(\mathbf{w}_1)} \sqrt{I(\mathbf{w}_2)}};$$

- area of a small surface on Σ : be $\mathbf{f}_{,u} du$ and $\mathbf{f}_{,v} dv$ two small vectors on Σ , forming together the angle θ , that are the transformed, through³ $\mathbf{f} : \Omega \rightarrow \Sigma$, of two small orthogonal vectors $du, dv \in \Omega$; then the area $d\mathcal{A}$ of the parallelogram determined by them is

$$\begin{aligned} d\mathcal{A} &= |\mathbf{f}_{,u} du \times \mathbf{f}_{,v} dv| = |\mathbf{f}_{,u} \times \mathbf{f}_{,v}| du dv = \sqrt{\mathbf{f}_{,u}^2 \mathbf{f}_{,v}^2 \sin^2 \theta} du dv \\ &= \sqrt{\mathbf{f}_{,u}^2 \mathbf{f}_{,v}^2 (1 - \cos^2 \theta)} du dv = \sqrt{\mathbf{f}_{,u}^2 \mathbf{f}_{,v}^2 - \mathbf{f}_{,u} \mathbf{f}_{,v} \cos^2 \theta} du dv \\ &= \sqrt{\mathbf{f}_{,u}^2 \mathbf{f}_{,v}^2 - (\mathbf{f}_{,u} \cdot \mathbf{f}_{,v})^2} du dv = \sqrt{\det \mathbf{g}} du dv; \end{aligned}$$

the term $\sqrt{\det \mathbf{g}}$ is hence the *dilatation factor of the areas*; recalling eq. (6.4), we see that the previous expression has a sense $\forall \mathbf{f}(u, v)$, i.e. for any parameterization of the surface.

7.5 Second fundamental form of a surface

Be $\mathbf{f} : \Omega \rightarrow \Sigma$ a regular surface, $\{\mathbf{f}_{,u}, \mathbf{f}_{,v}\}$ the natural basis for $T_p \Sigma$ and $\mathbf{N} \in \mathcal{S}$ the normal to Σ defined as in (7.2). We call *map of Gauss* of Σ the map $\varphi_\Sigma : \Sigma \rightarrow \mathcal{S}$ that associates to each $p \in \Sigma$ its $\mathbf{N} : \varphi_\Sigma(p) = \mathbf{N}(p)$. To each subset $\sigma \subset \Sigma$ the map of Gauss associates hence a subset $\sigma_\mathcal{S} \subset \mathcal{S}$, Fig. 7.4 (e.g. the Gauss map of a plane is just a point of \mathcal{S}).

We want to study how $\mathbf{N}(p)$ varies at the varying of p on Σ . To this purpose, we calculate the change of \mathbf{N} per unit length of a curve $\gamma(s) \in \Sigma$, i.e., we study how \mathbf{N} varies along any curve of Σ per unit of length of the curve itself; that is why we parameterize the curve with its arc-length s ⁴. Be $\mathbf{N} = N_i(u, v) \mathbf{e}_i$; then

$$\begin{aligned} \frac{d\mathbf{N}}{ds} &= \frac{dN_i(u(s), v(s))}{ds} \mathbf{e}_i = \left(\frac{\partial N_i}{\partial u} \frac{du}{ds} + \frac{\partial N_i}{\partial v} \frac{dv}{ds} \right) \mathbf{e}_i \\ &= \nabla N_i \cdot \boldsymbol{\tau} \mathbf{e}_i = (\mathbf{e}_i \otimes \nabla N_i) \boldsymbol{\tau} = (\nabla \mathbf{N}) \boldsymbol{\tau} = \frac{d\mathbf{N}}{d\boldsymbol{\tau}}. \end{aligned}$$

³For the sake of conciseness, from now on we will indicate a surface as the function $\mathbf{f} : \Omega \rightarrow \Sigma$, with $\mathbf{f} = \mathbf{f}(u, v)$, $(u, v) \in \Omega \subset \mathbb{R}^2$ and $\Sigma \subset \mathcal{E}$.

⁴Actually, it is possible to introduce the following concepts also more generally, for any parameterization of the curve; anyway, for the sake of simplicity, we will just use the parameter s in the following.

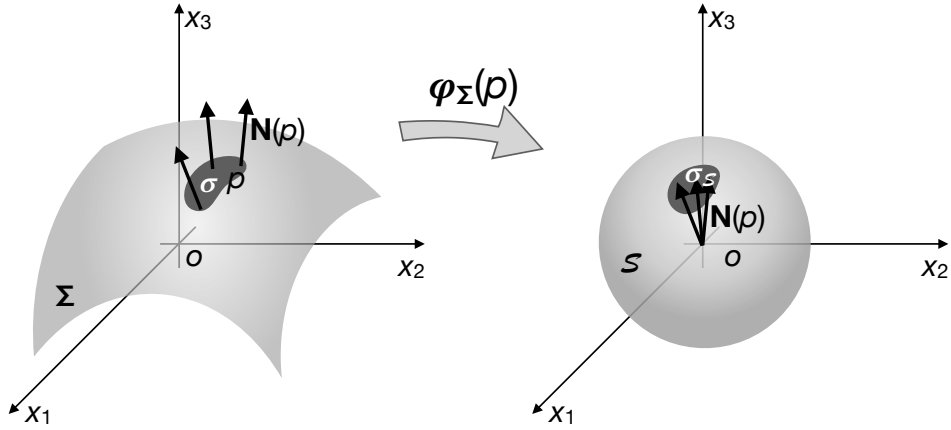

Figure 7.4: The map of Gauss.

The change of \mathbf{N} is hence related to the directional derivative of \mathbf{N} along the tangent $\boldsymbol{\tau}$ to $\gamma(s)$, which is a linear operator on $T_p\Sigma$. Moreover, as $\mathbf{N} \in \mathcal{S}$, then, cf. eq. (4.1),

$$\mathbf{N} \cdot \mathbf{N}_{,u} = \mathbf{N} \cdot \mathbf{N}_{,v} = 0 \Rightarrow \mathbf{N}_{,u}, \mathbf{N}_{,v} \in T_p\Sigma.$$

We then call *Weingarten operator* $\mathcal{L}_W : T_p\Sigma \rightarrow T_p\Sigma$ the opposite of the directional derivative of \mathbf{N} :

$$\mathcal{L}_W(\boldsymbol{\tau}) := -\frac{d\mathbf{N}}{d\boldsymbol{\tau}}.$$

Hence,

$$\mathcal{L}_W(\mathbf{f}_{,u}) = -\mathbf{N}_{,u}, \quad \mathcal{L}_W(\mathbf{f}_{,v}) = -\mathbf{N}_{,v}. \quad (7.10)$$

Because \mathcal{L}_W is linear, then it exists a tensor \mathbf{X} on $T_p\Sigma$ such that

$$\mathcal{L}_W(\mathbf{v}) = \mathbf{X}\mathbf{v} \quad \forall \mathbf{v} \in T_p\Sigma. \quad (7.11)$$

For any two vectors $\mathbf{w}_1, \mathbf{w}_2 \in T_p\Sigma$, we define *second fundamental form of a surface*, denoted by $II(\mathbf{w}_1, \mathbf{w}_2)$ the bilinear form

$$II(\mathbf{w}_1, \mathbf{w}_2) := I(\mathcal{L}_W(\mathbf{w}_1), \mathbf{w}_2).$$

Theorem 29. (*Symmetry of the second fundamental form*): $\forall \mathbf{w}_1, \mathbf{w}_2 \in T_p\Sigma$, $II(\mathbf{w}_1, \mathbf{w}_2) = II(\mathbf{w}_2, \mathbf{w}_1)$.

Proof. Because I and \mathcal{L}_W are linear, it is sufficient to prove the thesis for the natural basis $\{\mathbf{f}_{,u}, \mathbf{f}_{,v}\}$ of $T_p\Sigma$, and, by the symmetry of I , it is sufficient to prove that

$$I(\mathcal{L}_W(\mathbf{f}_{,u}), \mathbf{f}_{,v}) = I(\mathbf{f}_{,u}, \mathcal{L}_W(\mathbf{f}_{,v})),$$

i.e. that

$$I(-\mathbf{N}_{,u}, \mathbf{f}_{,v}) = I(\mathbf{f}_{,u}, -\mathbf{N}_{,v})$$

and in the end that

$$\mathbf{N}_{,u} \cdot \mathbf{f}_{,v} = \mathbf{f}_{,u} \cdot \mathbf{N}_{,v}.$$

To this end, we recall that

$$\mathbf{N} \cdot \mathbf{f}_{,u} = 0 = \mathbf{N} \cdot \mathbf{f}_{,v},$$

so, differentiating the first equation by v and the second one by u , we get

$$\mathbf{N}_{,v} \cdot \mathbf{f}_{,u} = -\mathbf{N} \cdot \mathbf{f}_{,uv} = \mathbf{N}_{,u} \cdot \mathbf{f}_{,v}. \quad (7.12)$$

□

The second fundamental form defines a quadratic, bilinear symmetric form:

$$II(\mathbf{w}_1, \mathbf{w}_2) = I(\mathcal{L}_W(\mathbf{w}_1), \mathbf{w}_2) = I(\mathbf{w}_1, \mathcal{L}_W(\mathbf{w}_2)) = I(\mathbf{w}_1, \mathbf{X}\mathbf{w}_2) = \mathbf{w}_1 \cdot \mathbf{g}\mathbf{X}\mathbf{w}_2 = \mathbf{w}_1 \cdot \mathbf{B}\mathbf{w}_2,$$

where

$$\mathbf{B} := \mathbf{g}\mathbf{X}. \quad (7.13)$$

In the natural basis $\{\mathbf{f}_{,u}, \mathbf{f}_{,v}\}$ of $T_p\Sigma$, by eq. (7.12), it is⁵

$$B_{ij} = II(\mathbf{f}_{,i}, \mathbf{f}_{,j}) = I(\mathcal{L}_W(\mathbf{f}_{,i}), \mathbf{f}_{,j}) = -\mathbf{N}_{,i} \cdot \mathbf{f}_{,j} = \mathbf{N} \cdot \mathbf{f}_{,ij}; \quad (7.14)$$

tensor \mathbf{X} can then be calculated by eq. (7.13):

$$\mathbf{X} = \mathbf{g}^{-1}\mathbf{B}. \quad (7.15)$$

By eq. (7.14), because $\mathbf{f}_{,ij} = \mathbf{f}_{,ji}$ or simply because $II(\cdot, \cdot)$ is symmetric, we get that

$$\mathbf{B} = \mathbf{B}^\top.$$

7.6 Curvatures of a surface

Be $\mathbf{f} : \Omega \rightarrow \Sigma$ a regular surface and $\gamma(s) : G \subset \mathbb{R} \rightarrow \Sigma$ a regular curve on Σ parameterized with the arc length s . We call *curvature vector of $\gamma(s)$* the vector $\boldsymbol{\kappa}(s)$ defined as

$$\boldsymbol{\kappa}(s) := c(s)\boldsymbol{\nu}(s) = \gamma''(s),$$

where $\boldsymbol{\nu}(s)$ is the principal normal to $\gamma(s)$. Then, we call *normal curvature $\kappa_N(s)$ of $\gamma(s)$* the projection of $\boldsymbol{\kappa}(s)$ onto $\mathbf{N}(s)$, the normal to Σ :

$$\kappa_N(s) := \boldsymbol{\kappa}(s) \cdot \mathbf{N}(s) = c(s) \boldsymbol{\nu}(s) \cdot \mathbf{N}(s) = \gamma''(s) \cdot \mathbf{N}(s).$$

⁵In many texts on differential geometry, the following symbols are used:

$$\begin{aligned} L &= \mathbf{f}_{,uu} \cdot \mathbf{N} = -\mathbf{f}_{,u} \cdot \mathbf{N}_{,u}, \\ M &= \mathbf{f}_{,uv} \cdot \mathbf{N} = -\mathbf{f}_{,u} \cdot \mathbf{N}_{,v}, \\ N &= \mathbf{f}_{,vv} \cdot \mathbf{N} = -\mathbf{f}_{,v} \cdot \mathbf{N}_{,v}. \end{aligned}$$

Theorem 30. *The normal curvature $\kappa_N(s)$ of $\gamma(s) \in \Sigma$ depends uniquely on $\tau(s)$:*

$$\kappa_N(s) = \tau(s) \cdot \mathbf{B}\tau(s) = II(\tau(s), \tau(s)). \quad (7.16)$$

Proof.

$$\gamma(s) = \gamma(u(s), v(s)) \rightarrow \tau(s) = \gamma'(s) = \mathbf{f}_{,u}u' + \mathbf{f}_{,v}v',$$

therefore $\tau = (u', v')$ in the natural basis and

$$\kappa(s) = \gamma''(s) = \mathbf{f}_{,u}u'' + \mathbf{f}_{,v}v'' + \mathbf{f}_{,uu}u'^2 + 2\mathbf{f}_{,uv}u'v' + \mathbf{f}_{,vv}v'^2$$

and finally, by eqs. (7.2) and (7.14),

$$\kappa_N(s) = \gamma''(s) \cdot \mathbf{N}(s) = B_{11}u'^2 + 2B_{12}u'v' + B_{22}v'^2 = \tau \cdot \mathbf{B}\tau = II(\tau, \tau).$$

□

If now $s = s(t)$ is a change of parameter for γ , then

$$\gamma'(t) = |\gamma'(t)|\tau(t),$$

so, by the linearity of $II(\cdot, \cdot)$ we get

$$II(\gamma'(t), \gamma'(t)) = |\gamma'(t)|^2 II(\tau(t), \tau(t)) = |\gamma'(t)|^2 \kappa_N(t)$$

and finally

$$\kappa_N(t) = \frac{II(\gamma'(t), \gamma'(t))}{I(\gamma'(t), \gamma'(t))}.$$

To each point $p \in \Sigma$ it corresponds uniquely (in the assumption of regularity of the surface $\mathbf{f} : \Omega \rightarrow \Sigma$) a tangent plane and a tangent space vector $T_p\Sigma$. In p , there are infinite tangent vectors to Σ , all of them belonging to $T_p\Sigma$. We can associate a curvature to each direction $\mathbf{t} \in T_p\Sigma$, i.e. to each tangent direction, in the following way: let us consider the bundle \mathcal{H} of planes whose support is the straight line through p and parallel to \mathbf{N} . Then any plane $H \in \mathcal{H}$ is a *normal plane to Σ in p* ; each normal plane is uniquely determined by a tangent direction \mathbf{t} and the (planar) curve $\gamma_{N\mathbf{t}} := H \cap \Sigma$ is called a *normal section of Σ* . If ν and \mathbf{N} are respectively the principal normal to $\gamma_{N\mathbf{t}}$ and the normal to Σ in p , then

$$\nu = \pm \mathbf{N}$$

for each normal section. We have in this way defined a function that to each tangent direction $\mathbf{t} \in T_p\Sigma$ associates the normal curvature κ_N of the normal section $\gamma_{N\mathbf{t}}$:

$$\kappa_N : \mathcal{S} \cap T_p\Sigma \rightarrow \mathbb{R} \quad \kappa_N(\mathbf{t}) = \frac{II(\mathbf{t}, \mathbf{t})}{I(\mathbf{t}, \mathbf{t})}.$$

By the bilinearity of the second fundamental form, $\kappa_N(\mathbf{t}) = \kappa_N(-\mathbf{t})$.

A point $p \in \Sigma$ is said to be a *umbilical point* if $\kappa_N(\mathbf{t}) = \text{const. } \forall \mathbf{t}$, it is a *planar point* if $\kappa_N(\mathbf{t}) = 0 \forall \mathbf{t}$. In all the other points, κ_N takes a minimum and a maximum value on distinct directions $\mathbf{t} \in T_p\Sigma$.

Because $\mathbf{B} = \mathbf{B}^\top$, by the spectral theorem it exists an orthonormal basis $\{\mathbf{u}_1, \mathbf{u}_2\}$ of $T_p\Sigma$ such that

$$\mathbf{B} = \beta_i \mathbf{u}_i \otimes \mathbf{u}_i,$$

with β_i the eigenvalues of \mathbf{B} . In such a basis, by eq. (7.13) we get

$$\kappa_N(\mathbf{u}_i) = \frac{II(\mathbf{u}_i, \mathbf{u}_i)}{I(\mathbf{u}_i, \mathbf{u}_i)} = \frac{\mathbf{u}_i \cdot \mathbf{B}\mathbf{u}_i}{\mathbf{u}_i \cdot \mathbf{g}\mathbf{u}_i} = \frac{\mathbf{u}_i \cdot \mathbf{g}\mathbf{X}\mathbf{u}_i}{\mathbf{u}_i \cdot \mathbf{g}\mathbf{u}_i}.$$

Then, because $\{\mathbf{u}_1, \mathbf{u}_2\}$ is an orthonormal basis, $\mathbf{g} = \mathbf{I}$ and

$$\kappa_N(\mathbf{u}_i) = \mathbf{u}_i \cdot \mathbf{X}\mathbf{u}_i = \beta_i,$$

i.e. \mathbf{X} and \mathbf{B} shares the same eigenvalues and eigenvectors. Moreover, cf. Sect. 2.8, we know that the two directions $\mathbf{u}_1, \mathbf{u}_2$ are the directions whereupon the quadratic form in the previous equation gets its maximum, κ_1 , and minimum, κ_2 , values, and in such a basis

$$\mathbf{X} = \kappa_i \mathbf{u}_i \otimes \mathbf{u}_i.$$

We call κ_1 and κ_2 the *principal curvatures of Σ in p* and $\mathbf{u}_1, \mathbf{u}_2$ the *principal directions of Σ in p* , see Fig. 7.5.

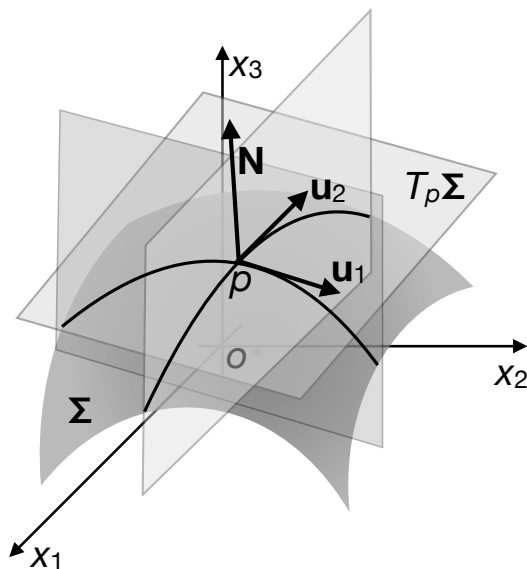

Figure 7.5: Principal curvatures.

We call *Gaussian curvature K* the product of the principal curvatures:

$$K := \kappa_1 \kappa_2 = \det \mathbf{X}.$$

By eq. (7.15) and the Theorem of Binet, it is also

$$K = \frac{\det \mathbf{B}}{\det \mathbf{g}}. \quad (7.17)$$

We define *mean curvature* H of a surface⁶ $\mathbf{f} : \Omega \rightarrow \Sigma$ at a point $p \in \Sigma$ the mean of the principal curvatures at p :

$$H := \frac{\kappa_1 + \kappa_2}{2} = \frac{1}{2} \operatorname{tr} \mathbf{X}.$$

Of course, a change of parameterization of a surface can change the orientation, cf. Sect. 7.1, which induces a change of \mathbf{N} into its opposite one and by consequence of the sign of the second fundamental form and hence of the normal and principal curvatures. These last are hence defined to less the sign, and the mean curvature too, while the principal directions, umbilicality, flatness and Gaussian curvature are intrinsic to Σ , i.e. they do not depend on its parameterization.

7.7 The theorem of Rodrigues

Principal directions of curvature have a property which is specified by the

Theorem 31. (*Theorem of Rodrigues*): be $\mathbf{f}(u, v)$ a surface of class at least C^2 and $\boldsymbol{\lambda} = (\lambda_u, \lambda_v) \in T_p \Sigma$; then

$$\frac{d\mathbf{N}(p)}{d\boldsymbol{\lambda}} = -\kappa_\lambda \boldsymbol{\lambda} \quad (7.18)$$

if and only if $\boldsymbol{\lambda}$ is a principal direction; κ_λ is the principal curvature relative to $\boldsymbol{\lambda}$.

Proof. Let $\boldsymbol{\lambda}$ be a principal direction of $T_p \Sigma$. Because $|\mathbf{N}| = 1$, then

$$\frac{d\mathbf{N}}{d\boldsymbol{\lambda}} \cdot \boldsymbol{\lambda} = 0; \quad (7.19)$$

moreover,

$$\frac{d\mathbf{N}}{d\boldsymbol{\lambda}} = \nabla \mathbf{N} \boldsymbol{\lambda} = \begin{bmatrix} 0 & 0 & 0 \\ 0 & 0 & 0 \\ \mathbf{N}_{,u} & \mathbf{N}_{,v} & 1 \end{bmatrix} \begin{pmatrix} \lambda_u \\ \lambda_v \\ 0 \end{pmatrix} = \mathbf{N}_{,u} \lambda_u + \mathbf{N}_{,v} \lambda_v. \quad (7.20)$$

Be $\boldsymbol{\mu} = (\mu_u, \mu_v)$ the other principal direction of $T_p \Sigma$; then

$$\boldsymbol{\lambda} \cdot \boldsymbol{\mu} = 0 \rightarrow I(\boldsymbol{\lambda}, \boldsymbol{\mu}) = II(\boldsymbol{\lambda}, \boldsymbol{\mu}) = 0.$$

Moreover

$$\frac{d\mathbf{N}}{d\boldsymbol{\lambda}} \cdot \boldsymbol{\mu} = -II(\boldsymbol{\lambda}, \boldsymbol{\mu}) = 0$$

which implies, together with eq. (7.19),

$$\frac{d\mathbf{N}}{d\boldsymbol{\lambda}} = \alpha \boldsymbol{\lambda}. \quad (7.21)$$

⁶The concept of mean curvature of a surface was introduced for the first time by Sophie Germain, in her celebrated work on the elasticity of plates.

Therefore

$$\frac{d\mathbf{N}}{d\boldsymbol{\lambda}} \cdot \boldsymbol{\lambda} = -II(\boldsymbol{\lambda}) = \alpha \boldsymbol{\lambda} \cdot \boldsymbol{\lambda} = \alpha I(\boldsymbol{\lambda})$$

and finally

$$\alpha = -\frac{II(\boldsymbol{\lambda})}{I(\boldsymbol{\lambda})} = -\kappa_\lambda.$$

Contrarily, if we assume eq. (7.21), like before we get $\alpha = -\kappa_\lambda$ and to end we just need to prove that $\boldsymbol{\lambda}$ is a principal direction. From eqs. (7.20) and (7.21) we get

$$\lambda_u \mathbf{N}_{,u} + \lambda_v \mathbf{N}_{,v} = -\kappa_\lambda (\lambda_u \mathbf{f}_{,u} + \lambda_v \mathbf{f}_{,v}).$$

Projecting this equation onto $\mathbf{f}_{,u}$ and $\mathbf{f}_{,v}$ gives the two equations

$$\begin{aligned} L\lambda_u + M\lambda_v &= \kappa_\lambda (E\lambda_u + F\lambda_v), \\ M\lambda_u + N\lambda_v &= \kappa_\lambda (E\lambda_u + G\lambda_v), \end{aligned} \tag{7.22}$$

with the symbols E, F, G, L, M and N defined in Notes 2 and 5. Let $\mathbf{w} = (w_u, w_v) \in T_p\Sigma$ and consider the function

$$\zeta(\mathbf{w}, \kappa_\lambda) = II(\mathbf{w}) - \kappa_\lambda I(\mathbf{w});$$

it is easy to check that ζ , $\frac{\partial \zeta}{\partial w_u}$ and $\frac{\partial \zeta}{\partial w_v}$ take zero value for $\mathbf{w} = \boldsymbol{\lambda}_0$, with $\boldsymbol{\lambda}_0$ the eigenvector of the principal direction relative to κ_λ , which gives the system of equations

$$\begin{cases} II(\boldsymbol{\lambda}_0) - \kappa_\lambda I(\boldsymbol{\lambda}_0) = 0, \\ \frac{\partial II(\boldsymbol{\lambda}_0)}{\partial w_u} - \kappa_\lambda \frac{\partial II(\boldsymbol{\lambda}_0)}{\partial w_u} = 0, \\ \frac{\partial II(\boldsymbol{\lambda}_0)}{\partial w_v} - \kappa_\lambda \frac{\partial II(\boldsymbol{\lambda}_0)}{\partial w_v} = 0. \end{cases}$$

Developing the derivatives and making some standard passages, eq. (7.22) is found again, which proves that $\boldsymbol{\lambda}$ is necessarily the principal direction relative to κ_λ . \square

This theorems states hence that the derivative of \mathbf{N} along a given direction is a vector parallel to such a direction only when this is a principal direction of curvature.

7.8 Classification of the points of a surface

Be $\mathbf{f} : \Omega \rightarrow \Sigma$ a regular surface and $p \in \Sigma$ a non-planar point. Then, we say that

- p is an *elliptic point* if $K(p) > 0$;
- p is a *hyperbolic point* if $K(p) < 0$;
- p is a *parabolic point* if $K(p) = 0$.

To remark that, by eq. (7.17), because $\det \mathbf{g} > 0$, eq. (6.4), the value of $\det \mathbf{B}$ is sufficient to determine the type of a point on Σ .

Theorem 32. *If p is an elliptical point of σ , then it exists a neighbourhood $U \in \Sigma$ of p such that all the points $q \in U$ belong to the same half-space into which \mathcal{E} is divided by the tangent plane $T_p\Sigma$.*

Proof. For the sake of simplicity and without loss of generality, we can always chose a parameterization $\mathbf{f}(u, v)$ of the surface such that $p = \mathbf{f}(0, 0)$. Expanding $\mathbf{f}(u, v)$ into a Taylor's series around $(0, 0)$ we get the position of a point $q = \mathbf{f}(u, v) \in \Sigma$ in the neighbourhood of p (though not indicated for the sake of shortness, all the derivatives are intended to be calculated at $(0, 0)$):

$$\mathbf{f}(u, v) = \mathbf{f}_u u + \mathbf{f}_v v + \frac{1}{2}(\mathbf{f}_{uu}u^2 + 2\mathbf{f}_{uv}uv + \mathbf{f}_{vv}v^2) + o(u^2 + v^2).$$

The distance with sign $d(q)$ of $q \in \Sigma$ from the tangent plane $T_p\Sigma$ is the projection onto \mathbf{N} , i.e.:

$$\begin{aligned} d(q) &= \frac{1}{2}(\mathbf{f}_{uu}u^2 + 2\mathbf{f}_{uv}uv + \mathbf{f}_{vv}v^2) \cdot \mathbf{N} + o(u^2 + v^2) \\ &= \frac{1}{2}(B_{11}u^2 + 2B_{12}uv + B_{22}v^2) + o(u^2 + v^2), \end{aligned}$$

or, which is the same, once put $\mathbf{w} = u\mathbf{f}_u + v\mathbf{f}_v$,

$$d(q) = II(\mathbf{w}, \mathbf{w}) + o(u^2 + v^2). \quad (7.23)$$

If p is an elliptic point, the principal curvatures have the same sign because $K = \kappa_1\kappa_2 > 0 \Rightarrow$ the sign of $II(\mathbf{w}, \mathbf{w})$ does not depend upon \mathbf{w} , i.e. upon the tangent vector. As a consequence the sign of $d(q)$ does not change with $\mathbf{w} \Rightarrow \forall q \in U$, Σ is on the same side of the tangent plane $T_p\Sigma$. \square

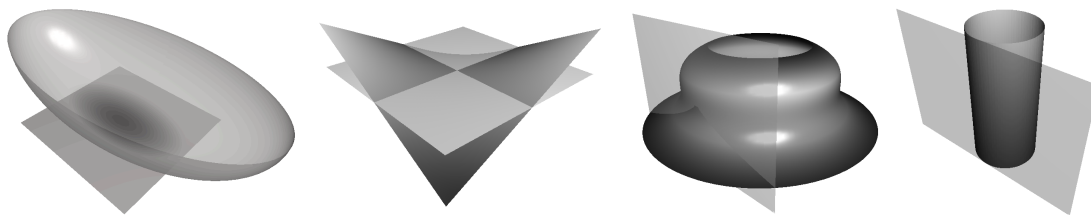

Figure 7.6: Elliptic, left, hyperbolic, center, and parabolic, the two last on the right, points.

Theorem 33. *If p is a hyperbolic point of Σ , then for each neighbourhood $U \in \Sigma$ of p there are points $q \in U$ that are in half-spaces on the opposite sides with respect to the tangent plane $T_p\Sigma$.*

Proof. The proof is identical to that of the previous theorem, until eq. (7.23); if now p is a hyperbolic point, the principal curvatures have opposite sign and by consequence $d(q)$ changes of sign at least two times in any neighbourhood U of $p \Rightarrow$ there are points $q \in U$ lying in half-spaces on the opposite sides with respect to the tangent plane $T_p\Sigma$. \square

In a parabolic point, there are different possibilities: Σ is on one side of the space with respect to $T_p\Sigma$, like for the case of a cylinder, or not, like, e.g., for the points $(0, v)$ of the surface, see Fig. 7.6,

$$\begin{cases} x = (u^3 + 2) \cos v, \\ y = (u^3 + 2) \sin v, \\ z = -u. \end{cases}$$

This is the case also for planar points: e.g., the point $(0, 0, 0)$ is a planar point for both the surfaces

$$z = x^4 + y^4, \quad z = x^3 - 3xy^2,$$

but in the first case, all the surface is on one side from the tangent plane, while it is on both sides for the second case (the so-called *monkey's saddle*), see Fig.7.7.

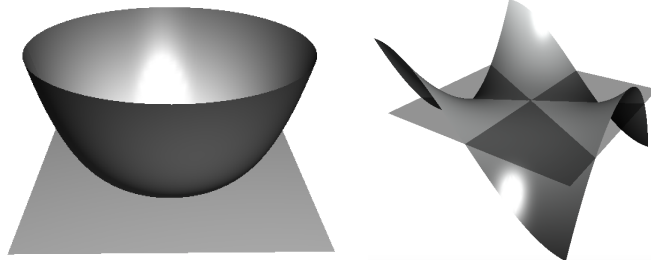

Figure 7.7: Two different planar points.

7.9 Developable surfaces

Let us now consider a ruled surface $\mathbf{f} : \Omega \rightarrow \Sigma$ like in eq. (7.7); then

$$\mathbf{f}_{,u} = \boldsymbol{\gamma}' + v\boldsymbol{\lambda}', \quad \mathbf{f}_{,v} = \boldsymbol{\lambda}, \quad \mathbf{f}_{,u} \times \mathbf{f}_{,v} = \boldsymbol{\gamma}' \times \boldsymbol{\lambda} + v\boldsymbol{\lambda}' \times \boldsymbol{\lambda}, \quad \mathbf{f}_{,uv} = \boldsymbol{\lambda}', \quad \mathbf{f}_{,vv} = \mathbf{o}.$$

by consequence, $B_{22} = \mathbf{N} \cdot \mathbf{f}_{,vv} = 0 \Rightarrow \det \mathbf{B} = -B_{12}^2$: the points of Σ are hyperbolic or parabolic. Namely, the parabolic points are those with

$$B_{12} = \mathbf{N} \cdot \mathbf{f}_{,uv} = \frac{\mathbf{f}_{,u} \times \mathbf{f}_{,v}}{|\mathbf{f}_{,u} \times \mathbf{f}_{,v}|} \cdot \mathbf{f}_{,uv} = 0 \iff (\boldsymbol{\gamma}' \times \boldsymbol{\lambda} + v\boldsymbol{\lambda}' \times \boldsymbol{\lambda}) \cdot \boldsymbol{\lambda}' = \boldsymbol{\gamma}' \times \boldsymbol{\lambda} \cdot \boldsymbol{\lambda}' = 0.$$

To remark that ruled surfaces made of parabolic points have *null Gaussian curvature everywhere*: $K = 0$.

Let us consider ruled surfaces having only parabolic points; then,

Theorem 34. *For a ruled surface $\mathbf{f}(u, v) = \boldsymbol{\gamma}(u) + v\boldsymbol{\lambda}(u)$, the following are equivalents:*

- i. $\boldsymbol{\gamma}', \boldsymbol{\lambda}, \boldsymbol{\lambda}'$ are linearly dependent;
- ii. $\mathbf{N}_{,v} = \mathbf{o}$.

Proof. Condition *ii* implies that \mathbf{N} does not change along a straight line lying on the ruled surface $\Rightarrow \mathbf{f}_{,u} \times \mathbf{f}_{,v} = \boldsymbol{\gamma}' \times \boldsymbol{\lambda} + v\boldsymbol{\lambda}' \times \boldsymbol{\lambda}$ does not depend on v as well. This is possible $\Leftrightarrow \boldsymbol{\gamma}' \times \boldsymbol{\lambda}$ and $\boldsymbol{\lambda}' \times \boldsymbol{\lambda}$ are linearly dependent, i.e. \Leftrightarrow

$$(\boldsymbol{\gamma}' \times \boldsymbol{\lambda}) \times (\boldsymbol{\lambda}' \times \boldsymbol{\lambda}) = (\boldsymbol{\lambda}' \times \boldsymbol{\lambda} \cdot \boldsymbol{\gamma}')\boldsymbol{\lambda} - (\boldsymbol{\lambda}' \times \boldsymbol{\lambda} \cdot \boldsymbol{\lambda})\boldsymbol{\gamma}' = (\boldsymbol{\lambda}' \times \boldsymbol{\lambda} \cdot \boldsymbol{\gamma}')\boldsymbol{\lambda} = \mathbf{o},$$

i.e. when $\boldsymbol{\lambda}, \boldsymbol{\lambda}'$ and $\boldsymbol{\gamma}'$ are coplanar, which proves the thesis. \square

We say that a ruled surface is *developable* if one of the conditions of Theorem 34 is satisfied. A developable surface is a surface that can be *flattened without distortion onto a plane*, i.e. it can be bent without stretching or shearing or vice-versa, it can be obtained by transforming a plane. To remark that only ruled surfaces are developable (but not all the ruled surfaces are developable).

It is immediate to check that a cylinder or a cone are developable surfaces, while the helicoid, the hyperbolic paraboloid or the hyperbolic paraboloid are not. Another classical example of developable surface is the *ruled surface of the tangents to a curve*: be $\boldsymbol{\gamma}(t) : G \subset \mathbb{R} \rightarrow \mathcal{E}$ a regular smooth curve; then the ruled surface of the tangents to $\boldsymbol{\gamma}$ is the surface $\mathbf{f}(u, v) : G \times \mathbb{R} \rightarrow \Sigma$ defined by

$$\mathbf{f}(u, v) = \boldsymbol{\gamma}(u) + v\boldsymbol{\gamma}'(u).$$

In Fig. 7.8, the ruled surface of the tangents to a cylindrical helix.



Figure 7.8: The ruled surface of the tangents to a cylindrical helix.

7.10 Points of a surface of revolution

Let us now consider a surface of revolution $\mathbf{f} : \Omega \rightarrow \Sigma_\gamma$ like in eq. (7.5) and, for the sake of simplicity, be u the natural parameter of the curve in eq. (7.4) generating the surface. Then

$$\varphi'^2(u) + \psi'^2(u) = 1, \quad \psi''(u)\varphi'(u) - \psi'(u)\varphi''(u) = c(u).$$

We can then calculate:

- the vectors of the natural basis:

$$\mathbf{f}_{,u} = \begin{Bmatrix} \varphi'(u) \cos v \\ \varphi'(u) \sin v \\ \psi'(u) \end{Bmatrix}, \quad \mathbf{f}_{,v} = \begin{Bmatrix} -\varphi(u) \sin v \\ \varphi(u) \cos v \\ 0 \end{Bmatrix};$$

- the normal to the surface

$$\mathbf{N} = \begin{Bmatrix} -\psi'(u) \cos v \\ -\psi'(u) \sin v \\ \varphi'(u) \end{Bmatrix};$$

- the metric tensor (i.e. the first fundamental form):

$$\mathbf{g} = \begin{bmatrix} 1 & 0 \\ 0 & \varphi^2(u) \end{bmatrix};$$

- the second derivatives of \mathbf{f} :

$$\mathbf{f}_{,uu} = \begin{Bmatrix} \varphi''(u) \cos v \\ \varphi''(u) \sin v \\ \psi''(u) \end{Bmatrix}, \quad \mathbf{f}_{,uv} = \begin{Bmatrix} -\varphi'(u) \sin v \\ \varphi'(u) \cos v \\ 0 \end{Bmatrix}, \quad \mathbf{f}_{,vv} = \begin{Bmatrix} -\varphi(u) \cos v \\ -\varphi(u) \sin v \\ 0 \end{Bmatrix};$$

- tensor \mathbf{B} (i.e. the second fundamental form):

$$\mathbf{B} = \begin{bmatrix} c(u) & 0 \\ 0 & \varphi(u)\psi'(u) \end{bmatrix};$$

- the Gaussian curvature K :

$$K = \det \mathbf{X} = \frac{\det \mathbf{B}}{\det \mathbf{g}} = \frac{c(u)\psi'(u)}{\varphi(u)}.$$

Therefore, points of Σ_γ where $c(u)$ and $\psi'(u)$ have the same sign are elliptic, hyperbolic otherwise. Parabolic points correspond to inflexion points of $\gamma(u)$, if $c(u) = 0$, or to points with horizontal tangent to $\gamma(u)$, if $\psi'(u) = 0$.

As an example, let us consider the case of the pseudo-sphere, eq. (7.6). Then,

$$\varphi(u) = \sin u, \quad \psi(u) = \cos u + \ln \tan \frac{u}{2}.$$

Some simple calculations give

$$\psi'(u) = -\sin u + \frac{1}{\sin u}, \quad c(u) = -\frac{|\tan u|}{|\cot u|};$$

by consequence

$$K = \frac{c(u)\psi'(u)}{\varphi(u)} = -\frac{(-\sin u + \frac{1}{\sin u})|\tan u|}{\sin u|\cot u|} = -1.$$

Finally, $K = \text{const.} = -1$, which is the reason for the name of this surface.

7.11 Lines of curvature, conjugated directions, asymptotic directions

A *line of curvature* is a curve on a surface with the property to be tangent, at each point, to a principal direction.

Theorem 35. *The lines of curvature of a surface are the solutions to the differential equation*

$$X_{21}u'^2 + (X_{22} - X_{11})u'v' - X_{12}v'^2 = 0.$$

Proof. A curve $\gamma(t) : G \subset \mathbb{R} \rightarrow \Sigma \subset \mathcal{E}$ is a line of curvature \iff

$$\gamma'(t) = \mathbf{f}_{,u}u' + \mathbf{f}_{,v}v'$$

is an eigenvector of $\mathbf{X}(t) \forall t$, i.e. \iff it exists a function $\mu(t)$ such that

$$\mathbf{X}(t)\gamma'(t) = \mu(t)\gamma'(t) \quad \forall t.$$

In the natural basis of $T_p\Sigma$, this condition reads like (we omit the dependence upon t for the sake of simplicity)

$$\begin{bmatrix} X_{11} & X_{12} \\ X_{21} & X_{22} \end{bmatrix} \begin{Bmatrix} u' \\ v' \end{Bmatrix} = \mu \begin{Bmatrix} u' \\ v' \end{Bmatrix},$$

which is satisfied \iff the two vectors at the left and right sides are proportional, i.e. if

$$\det \begin{bmatrix} X_{11}u' + X_{12}v' & u' \\ X_{21}u' + X_{22}v' & v' \end{bmatrix} = 0 \rightarrow X_{21}u'^2 + (X_{22} - X_{11})u'v' - X_{12}v'^2 = 0.$$

□

As a corollary, if \mathbf{X} is diagonal, then the coordinate lines are at the same time principal directions and lines of curvature.

Theorem 36. *A curve $\gamma(u) : G \subset \mathbb{R} \rightarrow \Sigma$ is a line of curvature \iff the surface*

$$\mathbf{f}(u, v) = \gamma(u) + v\mathbf{N}(\gamma(u)), \tag{7.24}$$

is developable.

Proof. From Theorem 34 $\mathbf{f}(u, v)$ is developable $\iff \gamma' \cdot \mathbf{N} \times \mathbf{N}' = 0$. Because γ' and $\mathbf{N}' \in T_p\Sigma$, which is orthogonal to \mathbf{N} , the surface will be developable $\iff \gamma' \times \mathbf{N}' = \mathbf{o}$. Moreover, writing

$$\gamma' = \mathbf{f}_{,u}u' + \mathbf{f}_{,v}v'$$

it is

$$\mathbf{N}' = \mathbf{N}_{,u}u' + \mathbf{N}_{,v}v' = -\mathcal{L}_W(\gamma'),$$

hence $\mathbf{f}(u, v)$ is developable $\iff \mathcal{L}_W(\gamma') \times \gamma' = \mathbf{o}$, i.e. when γ' is a principal direction. □

The curve in eq. (7.24) is called the *ruled surface of the normals*.

Be p a non-planar point of a surface $\mathbf{f} : \Omega \rightarrow \Sigma$ and $\mathbf{v}_1, \mathbf{v}_2$ two vectors of $T_p\Sigma$. We say that \mathbf{v}_1 and \mathbf{v}_2 are *conjugated* if $II(\mathbf{v}_1, \mathbf{v}_2) = 0$. The directions corresponding to \mathbf{v}_1 and \mathbf{v}_2 are

called *conjugated directions*. Hence, the principal directions at a point p are conjugated; if p is an umbilical point, any two orthogonal directions are conjugated.

The direction of a vector $\mathbf{v} \in T_p\Sigma$ is said to be *asymptotic* if it is *autoconjugated*, i.e. if $II(\mathbf{v}, \mathbf{v}) = 0$. An asymptotic direction is hence a direction where the normal curvature is null. In a hyperbolic point there are two asymptotic directions, in a parabolic point only one and in an elliptic point there are not asymptotic directions. An *asymptotic line* is a curve on a surface with the property of being tangent at every point to an asymptotic direction. The asymptotic lines are the solution of the differential equation

$$II(\gamma', \gamma') = 0 \rightarrow B_{11}u'^2 + 2B_{12}u'v' + B_{22}v'^2 = 0;$$

in particular, if $B_{11} = B_{22} = 0$ and $\mathbf{B} \neq \mathbf{O}$, then the coordinate lines are asymptotic lines. Asymptotic lines exist only in the regions where $K \leq 0$.

7.12 The Dupin's conical curves

The *conical curves of Dupin* are the real curves in $T_p\Sigma$ whose equations are

$$II(\mathbf{v}, \mathbf{v}) = \pm 1, \quad \mathbf{v} \in \mathcal{S}.$$

Be $\{\mathbf{u}_1, \mathbf{u}_2\}$ the basis of the principal directions. Using polar coordinates, we can write

$$\mathbf{v} = \rho \mathbf{e}_\rho, \quad \mathbf{e}_\rho = \cos \theta \mathbf{u}_1 + \sin \theta \mathbf{u}_2.$$

Therefore,

$$II(\mathbf{v}, \mathbf{v}) = \rho^2 II(\mathbf{e}_\rho, \mathbf{e}_\rho) = \rho^2 \kappa_N(\mathbf{e}_\rho),$$

and the conicals' equations are

$$\rho^2(\kappa_1 \cos^2 \theta + \kappa_2 \sin^2 \theta) = \pm 1.$$

With the Cartesian coordinates $\xi = \rho \cos \theta, \eta = \rho \sin \theta$, we get

$$\kappa_1 \xi^2 + \kappa_2 \eta^2 = \pm 1.$$

The type of conical curves depend upon the kind of point on Σ :

- elliptical points: the principal curvatures have the same sign \rightarrow one of the conical curves is an ellipse, the other one the null set (actually, it is not a real curve);
- hyperbolic points: the principal curves have opposite signs \rightarrow the conical curves are conjugated hyperbolae whose asymptotes coincide with the asymptotic directions;
- parabolic points: at least one of the principal curvatures is null \rightarrow one of the conical curves degenerates into a couple of parallel straight lines, corresponding to the asymptotic direction, the other one is the null set.

The three possible cases are depicted in Fig. 7.9

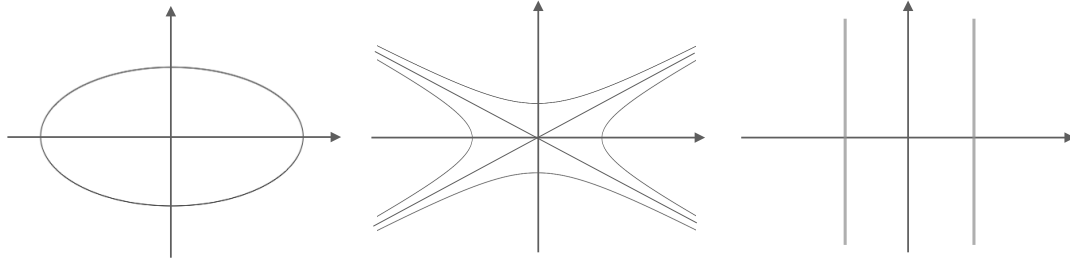

Figure 7.9: The conical curves of Dupin; from the left: elliptic, hyperbolic and parabolic points.

7.13 The Gauss-Weingarten equations

Be $\mathbf{f} : \Omega \rightarrow \Sigma$ a surface; for any point $p \in \Sigma$, consider the basis $\{\mathbf{f}_{,u}, \mathbf{f}_{,v}, \mathbf{N}\}$, also called the *Gauss' basis*. It is the equivalent of the Frenet-Serret basis for the surfaces. We want to calculate the derivatives of the vectors of this basis, i.e. we want to obtain, for the surfaces, something equivalent to the Frenet-Serret equations.

Generally speaking, $\mathbf{N} \in \mathcal{S}$ and $\mathbf{N} \cdot \mathbf{f}_{,u} = \mathbf{N} \cdot \mathbf{f}_{,v} = 0$, but $\mathbf{f}_{,u}, \mathbf{f}_{,v} \notin \mathcal{S}$ and $\mathbf{f}_{,u} \cdot \mathbf{f}_{,v} \neq 0$. In other words, we are in a case of non-orthogonal (curvilinear) coordinates. So, if w is the coordinate along the normal \mathbf{N} , let us call, for the sake of convenience,

$$u = z^1, \quad v = z^2,$$

while, for the vectors,

$$\mathbf{f}_{,u} = \mathbf{f}_{,1} = \mathbf{g}_1, \quad \mathbf{f}_{,v} = \mathbf{f}_{,2} = \mathbf{g}_2,$$

with $\mathbf{g}_1, \mathbf{g}_2$ exactly the \mathbf{g} -vectors of the coordinate lines on Σ . Then:

$$\begin{aligned} \frac{\partial \mathbf{g}_i}{\partial z^j} \cdot \mathbf{g}_i &= \frac{1}{2} \frac{\partial (\mathbf{g}_i \cdot \mathbf{g}_i)}{\partial z^j} = \frac{1}{2} \frac{\partial g_{ii}}{\partial z^j}, \\ \frac{\partial \mathbf{g}_i}{\partial z^i} \cdot \mathbf{g}_j &= \frac{\partial (\mathbf{g}_i \cdot \mathbf{g}_j)}{\partial z^i} - \frac{\partial \mathbf{g}_i}{\partial z^j} \cdot \mathbf{g}_i = \frac{\partial g_{ij}}{\partial z^i} - \frac{1}{2} \frac{\partial g_{ii}}{\partial z^j}, \end{aligned} \quad i, j = 1, 2;$$

for the last equation we have used the identity

$$\frac{\partial \mathbf{g}_j}{\partial z^i} = \mathbf{f}_{,ji} = \mathbf{f}_{,ij} = \frac{\partial \mathbf{g}_i}{\partial z^j}, \quad i, j = 1, 2.$$

Using eq. (6.25), it can be proved that it is also⁷

$$\frac{\partial \mathbf{g}_i}{\partial z^j} \cdot \mathbf{g}_h = \Gamma_{ij}^h \quad i, j, h = 1, 2.$$

Moreover, by eq. (7.14),

$$\frac{\partial \mathbf{g}_i}{\partial z^j} \cdot \mathbf{N} = \mathbf{f}_{,ij} \cdot \mathbf{N} = B_{ij} \quad i, j = 1, 2,$$

⁷The proof is rather cumbersome and it is omitted here; in many texts on differential geometry, the Christoffel symbols are just introduced in this way, as the projection of the derivatives of vectors \mathbf{g}_i s onto the same vectors, i.e. as the coefficients of the Gauss equations.

and, by eqs. (7.10), (7.11),

$$\frac{\partial \mathbf{N}}{\partial z^i} \cdot \mathbf{g}_j = -\mathcal{L}_W(\mathbf{g}_i) \cdot \mathbf{g}_j = -\mathbf{X}\mathbf{g}_i \cdot \mathbf{g}_j = -X_{ji}, \quad i, j = 1, 2,$$

while, because $|\mathbf{N}| = \text{const.} = 1$, then, eq. (4.1),

$$\frac{\partial \mathbf{N}}{\partial z^i} \cdot \mathbf{N} = 0 \quad \forall i = 1, 2.$$

Finally, the decomposition of the derivatives of the vectors of the basis $\{\mathbf{f}_u, \mathbf{f}_v, \mathbf{N}\}$ onto these same vectors gives the equations

$$\begin{aligned} \frac{\partial \mathbf{g}_i}{\partial z^j} &= \Gamma_{ij}^h \mathbf{g}_h + B_{ij} \mathbf{N}, \\ \frac{\partial \mathbf{N}}{\partial z^j} &= -X_{ij} \mathbf{g}_i, \end{aligned} \quad i, j = 1, 2; \quad (7.25)$$

these are the *Gauss-Weingarten equations* (the first one is due to Gauss and the second to Weingarten).

If now we make the scalar product of the Gauss equations by \mathbf{g}_1 and \mathbf{g}_2 , i.e.

$$\mathbf{g}_k \cdot \frac{\partial \mathbf{g}_i}{\partial z^j} = \mathbf{g}_k \cdot (\Gamma_{ij}^h \mathbf{g}_h + B_{ij} \mathbf{N}), \quad i, j, k = 1, 2,$$

we get the following three systems of equations:

$$\begin{cases} \Gamma_{11}^1 g_{11} + \Gamma_{11}^2 g_{21} = \frac{1}{2} \frac{\partial g_{11}}{\partial z^1}, \\ \Gamma_{11}^1 g_{12} + \Gamma_{11}^2 g_{22} = \frac{\partial g_{12}}{\partial z^1} - \frac{1}{2} \frac{\partial g_{11}}{\partial z^2}; \end{cases} \quad (7.26)$$

$$\begin{cases} \Gamma_{12}^1 g_{11} + \Gamma_{12}^2 g_{21} = \frac{1}{2} \frac{\partial g_{11}}{\partial z^2}, \\ \Gamma_{12}^1 g_{12} + \Gamma_{12}^2 g_{22} = \frac{1}{2} \frac{\partial g_{22}}{\partial z^1}; \end{cases} \quad (7.27)$$

$$\begin{cases} \Gamma_{22}^1 g_{11} + \Gamma_{22}^2 g_{21} = \frac{\partial g_{12}}{\partial z^2} - \frac{1}{2} \frac{\partial g_{22}}{\partial z^1}, \\ \Gamma_{22}^1 g_{12} + \Gamma_{22}^2 g_{22} = \frac{1}{2} \frac{\partial g_{22}}{\partial z^2}. \end{cases} \quad (7.28)$$

The determinant of each one of these systems is just $\det \mathbf{g} \neq 0 \rightarrow$ it is possible to express the Christoffel symbols as functions of the g_{ij} s and of their derivatives, i.e. as functions of the first fundamental form (the metric tensor).

7.14 The *Theorema Egregium*

The following theorem is a fundamental result due to Gauss:

Theorem 37. (*Theorema Egregium*): the Gaussian curvature K of a surface $\mathbf{f}(u, v) : \Omega \rightarrow \Sigma$ depends only upon the first fundamental form of \mathbf{f} .

Proof. Let us write the identity

$$\frac{\partial^2 \mathbf{g}_1}{\partial z^1 \partial z^2} = \frac{\partial^2 \mathbf{g}_1}{\partial z^2 \partial z^1}$$

using the Gauss equations (7.25)₁:

$$\begin{aligned} \Gamma_{11}^1 \mathbf{g}_{1,2} + \Gamma_{11}^2 \mathbf{g}_{2,2} + B_{11} \mathbf{N}_{,2} + \Gamma_{11,2}^1 \mathbf{g}_1 + \Gamma_{11,2}^2 \mathbf{g}_2 + B_{11,2} \mathbf{N} = \\ \Gamma_{12}^1 \mathbf{g}_{1,1} + \Gamma_{12}^2 \mathbf{g}_{1,2} + B_{12} \mathbf{N}_{,1} + \Gamma_{12,1}^1 \mathbf{g}_1 + \Gamma_{12,1}^2 \mathbf{g}_2 + B_{12,1} \mathbf{N}, \end{aligned}$$

where, for the sake of shortness, we have abridged $\frac{\partial(\cdot)}{\partial z^j}$ by $(\cdot)_{,j}$. Then, we use again eqs. (7.25) to express $\mathbf{g}_{1,1}$, $\mathbf{g}_{1,2}$, $\mathbf{g}_{2,2}$, $\mathbf{N}_{,1}$ and $\mathbf{N}_{,2}$; after doing that and equating to 0 the coefficient of \mathbf{g}_2 we get

$$B_{11} X_{22} - B_{12} X_{21} = \Gamma_{11}^1 \Gamma_{12}^2 + \Gamma_{11}^2 \Gamma_{22}^2 + \Gamma_{11,2}^2 - \Gamma_{12}^1 \Gamma_{11}^2 - \Gamma_{12}^2 \Gamma_{12}^2 - \Gamma_{12,1}^2;$$

by eq. (7.13) we get that

$$B_{11} = g_{11} X_{11} + g_{12} X_{21}, \quad B_{12} = g_{11} X_{12} + g_{12} X_{22},$$

that injected into the previous equation gives

$$g_{11} \det \mathbf{X} = \Gamma_{11}^1 \Gamma_{12}^2 + \Gamma_{11}^2 \Gamma_{22}^2 + \Gamma_{11,2}^2 - \Gamma_{12}^1 \Gamma_{11}^2 - \Gamma_{12}^2 \Gamma_{12}^2 - \Gamma_{12,1}^2. \quad (7.29)$$

Putting equal to zero the coefficient of \mathbf{g}_1 a similar expression can be get also for g_{12} . Because \mathbf{g} is positive definite, it is not possible that $g_{11} = g_{12} = 0$. So, remembering that $K = \det \mathbf{X}$ and the result of the previous Section, we see that it is possible to express K through the coefficients of the first fundamental form and of its derivatives. \square

7.15 Minimal surfaces

A *minimal surface* is a surface $\mathbf{f} : \Omega \rightarrow \Sigma$ having the mean curvature $H = 0 \forall p \in \Sigma$. Typical minimal surfaces are the catenoid and the helicoid. Other minimal surfaces are the *Enneper's surface*

$$\begin{cases} x_1 u - \frac{u^3}{3} + uv^2, \\ x_2 = v - \frac{v^3}{3} + u^2 v, \\ x_3 = u^2 - v^2, \end{cases}$$

the *Costa's surface* and the *Schoen's gyroid*, Fig. 7.10.

Theorem 38. *The non-planar points of a minimal surface are hyperbolic.*

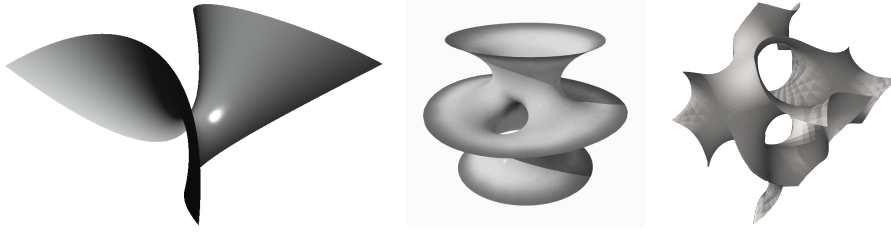

Figure 7.10: From the left, the minimal surfaces of Enneper, Costa and Schoen.

Proof. This is a direct consequence of the definition of mean curvature H and of hyperbolic points: $H = 0 \iff \kappa_1\kappa_2 < 0$. \square

Be $\mathbf{f} : \Omega \rightarrow \Sigma$ a regular surface and Q a subset of Ω with its boundary ∂Q a closed regular curve in Ω ; then $R = \mathbf{f}(Q) \subset \Sigma$ is a *simple region* of Σ . Let $h : Q \rightarrow \mathbb{R}$ a smooth function. Then, we call *normal variation of R* the map $\varphi : Q \times (-\epsilon, \epsilon) \rightarrow \mathcal{E}$ defined by

$$\varphi(u, v, t) = \mathbf{f}(u, v) + t h(u, v)\mathbf{N}(u, v).$$

For each fixed t , $\varphi(u, v, t)$ is a surface with

$$\begin{aligned} \varphi_{,u}(u, v, t) &= \mathbf{f}_{,u}(u, v) + t h(u, v)\mathbf{N}_{,u}(u, v) + t h_{,u}(u, v)\mathbf{N}(u, v), \\ \varphi_{,v}(u, v, t) &= \mathbf{f}_{,v}(u, v) + t h(u, v)\mathbf{N}_{,v}(u, v) + t h_{,v}(u, v)\mathbf{N}(u, v). \end{aligned}$$

If the first fundamental form of \mathbf{f} is represented by the metric tensor \mathbf{g} , we look for the metric tensor \mathbf{g}^t representing the first fundamental form of $\varphi(u, v, t) \forall t$:

$$\begin{aligned} g_{11}^t &= \varphi_{,u} \cdot \varphi_{,u} = g_{11} + 2t h \mathbf{f}_{,u} \cdot \mathbf{N}_{,u} + t^2(h^2\mathbf{N}_{,u}^2 + h_{,u}^2), \\ g_{12}^t &= \varphi_{,u} \cdot \varphi_{,v} = g_{12} + t h(\mathbf{f}_{,u} \cdot \mathbf{N}_{,v} + \mathbf{f}_{,v} \cdot \mathbf{N}_{,u}) + t^2(h^2\mathbf{N}_{,u} \cdot \mathbf{N}_{,v} + h_u h_{,v}), \\ g_{22}^t &= \varphi_{,v} \cdot \varphi_{,v} = g_{22} + 2t h \mathbf{f}_{,v} \cdot \mathbf{N}_{,v} + t^2(h^2\mathbf{N}_{,v}^2 + h_{,v}^2), \end{aligned}$$

and by eq. (7.14)

$$\begin{aligned} g_{11}^t &= g_{11} - 2t h B_{11} + t^2(h^2\mathbf{N}_{,u}^2 + h_{,u}^2), \\ g_{12}^t &= g_{12} - 2t h B_{12} + t^2(h^2\mathbf{N}_{,u} \cdot \mathbf{N}_{,v} + h_u h_{,v}), \\ g_{22}^t &= g_{22} - 2t h B_{22} + t^2(h^2\mathbf{N}_{,v}^2 + h_{,v}^2), \end{aligned}$$

whence

$$\det \mathbf{g}^t = \det \mathbf{g} - 2th(g_{11}B_{22} - 2g_{12}B_{12} + g_{22}B_{11}) + o(t^2).$$

Then, by eq. (7.15), we get easily that

$$g_{11}B_{22} - 2g_{12}B_{12} + g_{22}B_{11} = 2H \det \mathbf{g},$$

so that

$$\det \mathbf{g}^t = \det \mathbf{g}(1 - 4thH) + o(t^2).$$

We can now calculate the area $\mathcal{A}(t)$ of the simple region $R^t = \varphi(u, v, t)$ corresponding to the subset Q :

$$\mathcal{A}^t = \int_Q \sqrt{\det \mathbf{g}(1 - 4thH) + o(t^2)} dudv;$$

For $\epsilon \ll 1$ \mathcal{A}^t is differentiable and its derivative for $t = 0$ is

$$\left[\frac{d\mathcal{A}^t}{dt} \right]_{t=0} = - \int_Q 2hH \sqrt{\det \mathbf{g}} du dv.$$

Theorem 39. A surface $\mathbf{f} : \Omega \rightarrow \Sigma$ is minimal $\iff \left[\frac{d\mathcal{A}^t}{dt} \right]_{t=0} = 0 \quad \forall R \subset \Sigma$ and for each normal variation.

Proof. If \mathbf{f} is minimal, the condition is clearly satisfied ($H = 0$). Conversely, let us suppose that $\exists p = \mathbf{f}(\bar{u}, \bar{v}) \in \Sigma |H(p) \neq 0$. Be $r_1, r_2 \in \mathbb{R}$ such that $|H| \neq 0$ in the circle D_2 with center p and radius r_2 and $|H| > \frac{1}{2}|H(p)|$ in the circle D_1 with center p and radius r_1 . Then, we chose a smooth function $h(u, v)$ such that *i.* $h = H$ inside D_1 , *ii.* $hH > 0$ inside D_2 and *iii.* $h = 0$ outside D_2 . For the normal variation defined by such $h(u, v)$ we have

$$\begin{aligned} - \left[\frac{d\mathcal{A}^t}{dt} \right]_{t=0} &= \int_{D_2} 2hH \sqrt{\det \mathbf{g}} du dv \geq \int_{D_1} 2H^2 \sqrt{\det \mathbf{g}} du dv \\ &\geq \int_{D_1} \frac{H(p)^2}{2} \sqrt{\det \mathbf{g}} du dv = \frac{H(p)^2}{2} \mathcal{A}(\mathbf{f}(D_1)) \\ &\Rightarrow \left[\frac{d\mathcal{A}^t}{dt} \right]_{t=0} < 0 \end{aligned}$$

which contradicts the hypithesis. □

The meaning of this theorem justifies the name of minimal surfaces: these are the surfaces that have the minimal area among all the surfaces that share the same boundary.

7.16 Geodesics

Be $\mathbf{f} : \Omega \rightarrow \Sigma$ a surface and $\gamma(t) : G \subset \mathbb{R} \rightarrow \Sigma$ a curve on Σ . A vector function $\mathbf{w}(t) : G \rightarrow T_{\gamma(t)}\Sigma$ is called a *vector field*⁸ along $\gamma(t)$. We call *covariant derivative of $\mathbf{w}(t)$ along $\gamma(t)$* the vector field $D_\gamma \mathbf{w}(t) : G \rightarrow \mathcal{V}$ defined as⁹

$$D_\gamma \mathbf{w} := (\mathbf{I} - \mathbf{N} \otimes \mathbf{N}) \frac{d\mathbf{w}}{dt},$$

i.e. the projection of the derivative of \mathbf{w} onto $T_{\gamma(t)}\Sigma$. It is always possible to decompose $\mathbf{w}(t)$ into its components in the natural basis $\{\mathbf{f}_u, \mathbf{f}_v\}$:

$$\mathbf{w}(t) = w_1(t)\mathbf{f}_u(\gamma(t)) + w_2(t)\mathbf{f}_v(\gamma(t)).$$

Differentiating we get (a prime here denotes the derivative with respect to t)

$$\mathbf{w}' = w_1' \mathbf{f}_u + w_1 (\mathbf{f}_{uu} u' + \mathbf{f}_{uv} v') + w_2' \mathbf{f}_v + w_2 (\mathbf{f}_{uv} u' + \mathbf{f}_{vv} v')$$

⁸More correctly, $\mathbf{w}(t)$ is a curve of vectors; however, it is normally called a vector field along a curve.

⁹The operator that gives the projection of \mathbf{w} onto a vector orthogonal to $\mathbf{N} \in \mathcal{S}$, i.e. onto $T_{\gamma(t)}\Sigma$, is $\mathbf{I} - \mathbf{N} \otimes \mathbf{N}$, cf. ex. 2, Chap.2.

and using the Gauss equations, eq. (7.25)₁, we get (summation on the dummy indexes, u_1 stands for u and u_2 for v)

$$\mathbf{w}' = \mathbf{f}_{,k} w'_k + (\Gamma_{ij}^k \mathbf{f}_{,k} + B_{ij} \mathbf{N}) w_i u'_j, \quad i, j, k = 1, 2,$$

so that the projection onto $T_{\gamma(t)}\Sigma$, i.e. $D_\gamma \mathbf{w}(t)$ is

$$D_\gamma \mathbf{w} = (w'_k + \Gamma_{ij}^k w_i u'_j) \mathbf{f}_{,k}. \quad (7.30)$$

A *parallel vector field* \mathbf{w} along γ is a vector field having $\mathbf{D}_\gamma \mathbf{w} = \mathbf{o} \forall t$. A regular curve γ is a *geodesic* of Σ if the vector field γ' of the vectors tangent to γ is parallel along γ .

Theorem 40. *A curve γ is a geodesic of $\Sigma \iff \boldsymbol{\nu} \times \mathbf{N} = \mathbf{o}$.*

Proof. If γ is a geodesic, then the derivative of its tangent γ' has a component only along \mathbf{N} , i.e. $\gamma'' \times \mathbf{N} = \mathbf{o} \Rightarrow \gamma' \cdot \gamma'' = 0$. The principal normal to γ , $\boldsymbol{\nu}$, is orthogonal to $\gamma' \Rightarrow \boldsymbol{\nu} \times \mathbf{N} = \mathbf{o}$. Vice versa, if $\boldsymbol{\nu} \times \mathbf{N} = \mathbf{o}$, then γ'' is orthogonal to $\gamma' \Rightarrow \mathbf{D}_\gamma \gamma' = \mathbf{o}$, i.e. γ is a geodesic. \square

Theorem 41. *If γ is a geodesic, then $|\gamma'| = \text{const}$.*

Proof. In a geodesic $\gamma' \cdot \gamma'' = 0 \Rightarrow \frac{d(\gamma' \cdot \gamma')}{dt} = 0 \Rightarrow |\gamma'| = \text{const}$. \square

This result shows that in a geodesic the parameter is always a multiple of the natural parameter s .

Be $\gamma(s)$ a curve on Σ parameterized by the the arc-length s . We call *geodesic curvature* of $\gamma(s)$ the function

$$\kappa_g := D_\gamma \boldsymbol{\tau} \cdot (\mathbf{N} \times \boldsymbol{\tau}),$$

where $\boldsymbol{\tau} = \gamma' \in \mathcal{S}$ is the tangent vector to γ . Because $\mathbf{N} \times \boldsymbol{\tau} \in \mathcal{S}$ lies in $T_\gamma \Sigma$, the component of $\boldsymbol{\tau}'$ orthogonal to $T_\gamma \Sigma$ gives a null contribution to κ_g , so we can write also

$$\kappa_g = \boldsymbol{\tau}' \cdot (\mathbf{N} \times \boldsymbol{\tau}).$$

Theorem 42. *A regular curve $\gamma(s)$ is a geodesic $\iff \kappa_g = 0 \forall s$.*

Proof. If γ is a geodesic, clearly $\kappa_g = 0$. Vice versa, if $\kappa_g = 0$, then $\boldsymbol{\tau}, \boldsymbol{\tau}'$ and \mathbf{N} are linearly dependent, i.e. coplanar. Because $\boldsymbol{\tau}' \cdot \boldsymbol{\tau} = \mathbf{N} \cdot \boldsymbol{\tau} = 0 \Rightarrow \boldsymbol{\tau}' \times \mathbf{N} = \mathbf{o} \Rightarrow$ by Theorem 40, γ is a geodesic. \square

Let us now write eq. (7.30) in the particular case of $\mathbf{w} = \gamma'$, i.e. $w_1 = u', w_2 = v'$:

$$D_\gamma \mathbf{w} = (u''_k + \Gamma_{ij}^k u'_i u'_j) \mathbf{f}_{,k};$$

therefore, the geodesics are the solutions to the system of differential equations

$$\begin{cases} u'' + \Gamma_{11}^1 u'^2 + 2\Gamma_{12}^1 u'v' + \Gamma_{22}^1 v'^2 = 0, \\ v'' + \Gamma_{11}^2 u'^2 + 2\Gamma_{12}^2 u'v' + \Gamma_{22}^2 v'^2 = 0. \end{cases} \quad (7.31)$$

It can be shown that $\forall p \in \Sigma$ and $\forall \mathbf{w}(p) \in T_p \Sigma$ the geodesic is unique.

Be p a point of a regular surface $\mathbf{f} : \Omega \rightarrow \Sigma$, $\alpha(v) : G \subset \mathbb{R} \rightarrow \Sigma$ a smooth regular curve on Σ , v being the natural parameter and such that $p = \alpha(0)$. Consider the geodesic γ_v passing through $q = \alpha(v)$ and such that $\gamma'_v(0) = \mathbf{N}(\alpha(v)) \times \boldsymbol{\tau}(v)$, with $\boldsymbol{\tau}(v)$ the (unit) tangent vector to $\alpha(v)$. Consider the map $\mathbf{f}(u, v) : \Omega \rightarrow \Sigma$ defined posing $\mathbf{f}(u, v) = \gamma_v(u)$; this is a surface whose coordinates (u, v) are called *semigeodesic coordinates*.

Let us see the form that the first fundamental form (i.e. the metric tensor \mathbf{g}), the Christoffel symbols and the Gaussian curvature take in semigeodesic coordinates. Curves $\mathbf{f}(u, v_0) = \gamma_{v_0}(u)$ are geodesics and u is hence their natural parameter. Therefore, $\mathbf{f}_{,u} \in \mathcal{S} \Rightarrow g_{11} = 1$. Then, $\mathbf{f}_{uu}(u, v_0)$ is the derivative of the tangent vector to a geodesic $\mathbf{f}(u, v_0) = \gamma_{v_0}(u) \Rightarrow \mathbf{f}_{uu}(u, v_0)$ has not a component along the tangent, hence, eq. $\Rightarrow \Gamma_{11}^1 = \Gamma_{11}^2 = 0$. Then, by eq. (7.26)₁, we get $g_{12,u} = 0 \Rightarrow g_{12}$ does not depend upon $u \Rightarrow g_{12}(u, v) = g_{12}(0, v) \forall u$. Moreover, be θ the angle between the curve α , i.e. between the coordinate line $\mathbf{f}(0, v)$, whose tangent vector is $\mathbf{f}_{,v}(0, v)$, and the geodesic $\gamma_v(u)$, whose tangent vector at $(0, v)$ is $\gamma'_v(u)$. Then, $\theta = \frac{\pi}{2}$, because $\gamma'_v(0) = \mathbf{N}(\alpha(v)) \times \boldsymbol{\tau}(v)$. As a consequence, $g_{12}(0, v) = 0 \Rightarrow g_{12}(u, v) = 0 \forall (u, v) \in \Omega$. Finally, putting $\mathbf{g}_{22} = g$,

$$\mathbf{g} = \begin{bmatrix} 1 & 0 \\ 0 & g \end{bmatrix},$$

with $g > 0$ because \mathbf{g} is positive definite. Through systems (7.26), (7.27) and (7.28) we obtain

$$\Gamma_{12}^1 = 0, \quad \Gamma_{12}^2 = \frac{g_{,u}}{2g}, \quad \Gamma_{22}^1 = -\frac{g_{,u}}{2}, \quad \Gamma_{22}^2 = \frac{g_{,v}}{2g},$$

and using eq. (7.29) we obtain

$$K = \det \mathbf{X} = -\frac{g_{,uu}}{2g} + \frac{g_{,u}^2}{4g^2}.$$

Given two points $p_1, p_2 \in \Sigma$, we define the *distance* $d(p_1, p_2)$ as the infimum of the lengths of the curves on Σ that rely the two points. We end with an important characterisation of geodesics:

Theorem 43. *Geodesics are the curves of minimal distance between two points of a surface.*

Proof. Be $\gamma : G \subset \mathbb{R} \rightarrow \Sigma$ a geodesic on Σ , parameterized with the arc-length, and α a smooth regular curve through p and orthogonal to γ . Through α , we set up a system of semigeodesic coordinates in a neighbourhood U of p . With an opportune parameterization

$\alpha(t)$, in such coordinates we can get $p = \mathbf{f}(0, 0)$ and γ described by the equation $v = 0$. Be $q \in U$ a point of γ , and consider a regular curve connecting p with q . The length $\ell(p, q)$ of such curve is

$$\ell(p, q) = \int_p^q \sqrt{u'^2 + g v'^2} dt \geq \left| \int_p^q u' dt \right| = |u_q - u_p|.$$

Observing that $p = (u_p, 0), q = (u_q, 0)$, we remark that $|u_q - u_p|$ is exactly the length of γ between p and q , because γ is parameterized with its arc-length. \square

There is another, direct and beautiful way to show that geodesics are the shortest path lines: the use of the methods of the calculus of variations¹⁰. The length $\ell(p, q)$ of a curve $\gamma(t) \in \Sigma$ between two points p and q is given by the functional (7.9); it depends upon the first fundamental form, i.e. upon the metric tensor \mathbf{g} on σ . For the sake of conciseness, be $\mathbf{w} = (w_{,t}^1, w_{,t}^2)$ the tangent vector to the curve $\gamma(w_1, w_2) \in \Sigma$. Then,

$$\ell(p, q) = \int_p^q \sqrt{I(\mathbf{w})} dt = \int_p^q \sqrt{\mathbf{w} \cdot \mathbf{g} \mathbf{w}} dt.$$

The curve $\gamma(t)$ that minimizes $\ell(p, q)$ is the solution to the *Euler-Lagrange equations*

$$\frac{d}{dt} \frac{\partial F}{\partial \mathbf{w}_{,t}} - \frac{\partial F}{\partial \mathbf{w}} = \mathbf{o} \quad \rightarrow \quad \frac{d}{dt} \frac{\partial F}{\partial w_{,t}^k} - \frac{\partial F}{\partial w^k} = 0, \quad k = 1, 2,$$

where

$$F(\mathbf{w}, \mathbf{w}_{,t}, t) = \sqrt{\mathbf{w} \cdot \mathbf{g} \mathbf{w}} = \sqrt{g_{ij} w_{,t}^i w_{,t}^j}$$

It is more direct, and equivalent, to minimize $J^2(t)$, i.e. to write the Euler-Lagrange equations for

$$\Phi(\mathbf{w}, \mathbf{w}_{,t}, t) := F^2(\mathbf{w}, \mathbf{w}_{,t}, t) = g_{ij} w_{,t}^i w_{,t}^j.$$

Therefore:

$$\begin{aligned} \frac{\partial \Phi}{\partial w_{,t}^k} &= 2g_{jk} w_{,t}^j, \\ \frac{\partial \Phi}{\partial w^k} &= \frac{\partial g_{hj}}{\partial w^k} w_{,t}^h w_{,t}^j, & j, h, k = 1, 2. \\ \frac{d}{dt} \frac{\partial \Phi}{\partial w_{,t}^k} &= 2 \left(g_{jk} w_{,tt}^j + \frac{dg_{jk}}{dt} w_{,t}^j \right) = 2 \left(g_{jk} w_{,tt}^j + \frac{\partial g_{jk}}{\partial w^l} w_{,t}^l w_{,t}^j \right), \end{aligned}$$

¹⁰The reader is addressed to texts on the calculus of variations for an insight in the matter, cf. **Suggested texts**. Here, we just recall the fundamental fact to be used in the proof concerning geodesics: be

$$J(t) = \int_a^b F(\mathbf{x}, \mathbf{x}', t) dt$$

a functional to be minimized by a proper choice of the function $\mathbf{x}(t)$ (in the case of the geodesics, $J = \ell(p, q)$); then, such a minimizing function can be found as solution of the *Euler-Lagrange equations*

$$\frac{d}{dt} \frac{\partial F}{\partial \mathbf{x}'} - \frac{\partial F}{\partial \mathbf{x}} = \mathbf{o}.$$

The Euler-Lagrange equations are hence

$$g_{jk}w_{,tt}^j + \frac{\partial g_{jk}}{\partial w^h}w_{,t}^h w_{,t}^j - \frac{1}{2} \frac{\partial g_{hj}}{\partial w^k}w_{,t}^h w_{,t}^j = 0, \quad j, h, k = 1, 2,$$

that can be rewritten as

$$g_{jk}w_{,tt}^j + \frac{1}{2} \left(\frac{\partial g_{jk}}{\partial w^h} + \frac{\partial g_{hk}}{\partial w^j} - \frac{\partial g_{hj}}{\partial w^k} \right) w_{,t}^h w_{,t}^j = 0, \quad j, h, k = 1, 2.$$

Multiplying by g^{lk} we get

$$g^{lk}g_{jk}w_{,tt}^j + \frac{1}{2}g^{lk} \left(\frac{\partial g_{jk}}{\partial w^h} + \frac{\partial g_{hk}}{\partial w^j} - \frac{\partial g_{hj}}{\partial w^k} \right) w_{,t}^h w_{,t}^j = 0, \quad j, h, k, l = 1, 2.$$

and finally, because

$$g^{lk}g_{jk} = \delta_{lj}$$

and by eq. (6.25), we get

$$w_{,tt}^l + \Gamma_{jh}^l w_{,t}^j w_{,t}^h, \quad j, h, l = 1, 2.$$

These are the differential equations whose solution is the curve of minimal length between two points of Σ ; comparing these equations with those of a geodesic of Σ , eq. (7.31), we see that they are the same: the geodesics of a surface are hence the curves of minimal distance on the surface.

The Christoffel symbols of a plane are all null; as a consequence, the geodesic lines of a plane are straight lines. In fact, only such lines have a constant derivative.

Through systems (7.26), (7.27) and (7.28) we can calculate the Christoffel symbols for a revolution surface, eq. (7.5), which are all null excepted

$$\Gamma_{12}^2 = \frac{\varphi'}{\varphi}, \quad \Gamma_{22}^1 = -\varphi \varphi',$$

so the system of differential equations (7.31) becomes

$$\begin{cases} u'' - \varphi \varphi' v'^2 = 0, \\ v'' + 2 \frac{\varphi'}{\varphi} u' v' = 0. \end{cases}$$

It is direct to check that the meridians ($u = t, v = v_0$) are geodesic lines, while the parallels ($u = u_0, v = t$) are geodesics $\iff \varphi'(u_0) = 0$.

7.17 The Gauss-Codazzi compatibility conditions

Let us consider a surface Σ whose points are determined by the vector function $\mathbf{r} : \Omega \subset \mathbb{R}^2 \rightarrow \Sigma \subset \mathcal{E}$, $\mathbf{r}(\alpha_1, \alpha_2) = x_i(\alpha_1, \alpha_2)\boldsymbol{\epsilon}_i$, with $\boldsymbol{\epsilon}_i, i = 1, 2, 3$, the vectors of the orthonormal basis of the reference frame $\mathcal{R} = \{o; \boldsymbol{\epsilon}_1, \boldsymbol{\epsilon}_2, \boldsymbol{\epsilon}_3\}$ and the parameters α_1, α_2 chosen in such

a way that the lines $\alpha_1 = \text{const.}$, $\alpha_2 = \text{const.}$ are lines of curvature, i.e. tangent at each point to the principal directions of curvature and hence mutually orthogonal¹¹. With such a choice, cf. eq. (7.8),

$$ds^2 = A_1^2 d\alpha_1^2 + A_2^2 d\alpha_2^2,$$

with

$$A_1 = \sqrt{\mathbf{r}_{\alpha_1}^2} = \sqrt{\frac{dx_i}{d\alpha_1} \frac{dx_i}{d\alpha_1}},$$

$$A_2 = \sqrt{\mathbf{r}_{\alpha_2}^2} = \sqrt{\frac{dx_i}{d\alpha_2} \frac{dx_i}{d\alpha_2}}$$

the so-called *Lamé's parameters*. We remark that along the lines of curvatures, i.e. the lines $\alpha_i = \text{const.}$, $i = 1, 2$, that in short from now on we will call the *lines* α_i , it is

$$ds_1 = A_1 d\alpha_1,$$

$$ds_2 = A_2 d\alpha_2,$$

and hence,

$$\boldsymbol{\lambda}_1 = \frac{ds_1}{d\alpha_1} = A_1 \mathbf{e}_1,$$

$$\boldsymbol{\lambda}_2 = \frac{ds_2}{d\alpha_2} = A_2 \mathbf{e}_2$$
(7.32)

are the vectors tangent to the lines of curvature. Be

$$\mathbf{e}_1 = \frac{1}{A_1} \mathbf{r}_{,\alpha_1}, \quad \mathbf{e}_2 = \frac{1}{A_2} \mathbf{r}_{,\alpha_2}, \quad \mathbf{e}_3 = \mathbf{e}_1 \times \mathbf{e}_2 (= \mathbf{N});$$
(7.33)

these three vectors form the orthonormal (local) natural basis $\mathbf{e} = \{\mathbf{e}_1, \mathbf{e}_2, \mathbf{e}_3\}$. We always make the choice of α_1, α_2 such that \mathbf{e}_3 is always directed to the convex side of Σ if the point is elliptic or parabolic, or to the side of the centres of negative curvature, if the point is hyperbolic.

We consider a vector $\mathbf{v} = \mathbf{v}(p)$, $p \in \Sigma$,

$$\mathbf{v} = v_1 \mathbf{e}_1 + v_2 \mathbf{e}_2 + v_3 \mathbf{e}_3,$$

and we want to calculate how it transforms when p changes. To this end, we need to calculate how $\mathbf{e}_1, \mathbf{e}_2, \mathbf{e}_3$ change with α_1, α_2 . Be $q \in \Sigma$ a point in the neighborhood of p on the line α_i and let us first consider the change of \mathbf{e}_3 in passing from p to q . Because p and q belong to the same line α_i , by the Theorem of Rodrigues we get (no summation on i in the following equations)

$$\frac{\partial \mathbf{e}_3}{\partial \lambda_i} = -\kappa_i \boldsymbol{\lambda}_i, \quad i = 1, 2,$$

¹¹The symbol \mathbf{r} is here preferred to \mathbf{f} , like α_1 to u and α_2 to v , to recall that we have made the particular choice of coordinate lines that are lines of curvature. All the developments could be done in a more general case, but this choice is made to obtain simpler relations, that preserves anyway the generality because the lines of curvature exist everywhere.

i.e., by eq. (7.32),

$$\frac{\partial \mathbf{e}_3}{\partial \alpha_i} = \frac{A_i}{R_i} \mathbf{e}_i,$$

with

$$R_i = -\frac{1}{\kappa_i}$$

the (principal) radius of curvature along the line α_i . The sign minus in the previous equation is due to the choice done above for orienting $\mathbf{e}_3 = \mathbf{N}$, that gives always $\mathbf{N} = -\boldsymbol{\nu}$, with $\boldsymbol{\nu}$ the principal normal to the line α_i . This result can be obtained also directly, see Fig. 7.11:

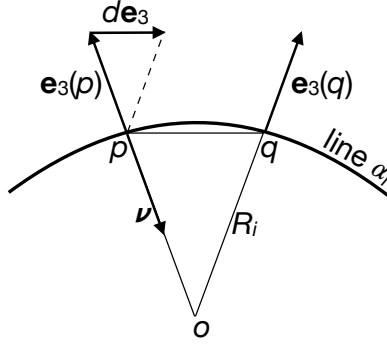

Figure 7.11: Variation of $\mathbf{N} = \mathbf{e}_3$ along a line of curvature.

$$\mathbf{e}_3(q) = \mathbf{e}_3(p) + d\mathbf{e}_3$$

and in the limit of $q \rightarrow p$, $d\mathbf{e}_3$ tends to be parallel to $q - p$ and

$$\lim_{q \rightarrow p} (q - p) = \boldsymbol{\lambda}_i = A_i \mathbf{e}_i.$$

By the similitude of the triangles, it is evident that

$$\frac{|d\mathbf{e}_3|}{|\mathbf{e}_3|} = \frac{|q - p|}{R_i},$$

moreover,

$$d\mathbf{e}_3 = \frac{\partial \mathbf{e}_3}{\partial \alpha_i} d\alpha_i \mathbf{e}_i.$$

Finally, as $|\mathbf{e}_3| = 1$, we get again

$$\frac{\partial \mathbf{e}_3}{\partial \alpha_i} = \frac{A_i}{R_i} \mathbf{e}_i. \quad (7.34)$$

Implicitly, in this last proof, we have used the Theorem of Rodrigues, because we have assumed that $d\mathbf{e}_3$ is parallel to $\boldsymbol{\lambda}_i$, as it is, because line α_i is a line of curvature.

We pass now to determine the changes of \mathbf{e}_1 and \mathbf{e}_2 ; to this purpose, we remark that

$$\frac{\partial \mathbf{r}_{,\alpha_1}}{\partial \alpha_2} = \frac{\partial^2 \mathbf{r}}{\partial \alpha_2 \partial \alpha_1} = \frac{\partial^2 \mathbf{r}}{\partial \alpha_1 \partial \alpha_2} = \frac{\partial \mathbf{r}_{,\alpha_2}}{\partial \alpha_1},$$

so by eq. (7.33) we get

$$\frac{\partial(A_1 \mathbf{e}_1)}{\partial \alpha_2} = \frac{\partial(A_2 \mathbf{e}_2)}{\partial \alpha_1}. \quad (7.35)$$

Let us study now $\frac{\partial \mathbf{e}_j}{\partial \alpha_i}$; as $|\mathbf{e}_j| = 1, j = 1, 2$,

$$\frac{\partial \mathbf{e}_j}{\partial \alpha_i} \cdot \mathbf{e}_j = 0 \quad \forall i, j = 1, 2. \quad (7.36)$$

Because $\mathbf{e}_1 \cdot \mathbf{e}_2 = 0$,

$$\frac{\partial \mathbf{e}_1}{\partial \alpha_1} \cdot \mathbf{e}_2 = \frac{\partial(\mathbf{e}_1 \cdot \mathbf{e}_2)}{\partial \alpha_1} - \mathbf{e}_1 \cdot \frac{\partial \mathbf{e}_2}{\partial \alpha_1} = -\mathbf{e}_1 \cdot \frac{\partial \mathbf{e}_2}{\partial \alpha_1}.$$

By eq. (7.35) we get

$$\frac{\partial \mathbf{e}_2}{\partial \alpha_1} = \frac{1}{A_2} \frac{\partial(A_1 \mathbf{e}_1)}{\partial \alpha_2} - \frac{1}{A_2} \frac{\partial A_2}{\partial \alpha_1} \mathbf{e}_2,$$

that injected in the previous equation gives, by eq. (7.36),

$$\frac{\partial \mathbf{e}_1}{\partial \alpha_1} \cdot \mathbf{e}_2 = -\frac{1}{A_2} \frac{\partial(A_1 \mathbf{e}_1)}{\partial \alpha_2} \cdot \mathbf{e}_1 + \frac{1}{A_2} \frac{\partial A_2}{\partial \alpha_1} \mathbf{e}_2 \cdot \mathbf{e}_1 = -\frac{A_1}{A_2} \frac{\partial \mathbf{e}_1}{\partial \alpha_2} \cdot \mathbf{e}_1 - \frac{1}{A_2} \frac{\partial A_1}{\partial \alpha_2} \mathbf{e}_1 \cdot \mathbf{e}_1 = -\frac{1}{A_2} \frac{\partial A_1}{\partial \alpha_2}.$$

Then, because $\mathbf{e}_1 \cdot \mathbf{e}_3 = 0$,

$$\frac{\partial \mathbf{e}_1}{\partial \alpha_1} \cdot \mathbf{e}_3 = \frac{\partial(\mathbf{e}_1 \cdot \mathbf{e}_3)}{\partial \alpha_1} - \mathbf{e}_1 \cdot \frac{\partial \mathbf{e}_3}{\partial \alpha_1} = -\mathbf{e}_1 \cdot \frac{\partial \mathbf{e}_3}{\partial \alpha_1},$$

and by eq. (7.34)

$$\frac{\partial \mathbf{e}_3}{\partial \alpha_1} = \frac{A_1}{R_1} \mathbf{e}_1,$$

so finally

$$\frac{\partial \mathbf{e}_1}{\partial \alpha_1} \cdot \mathbf{e}_3 = -\frac{A_1}{R_1}.$$

Again through eqs. (7.35) and (7.36) we get

$$\frac{\partial \mathbf{e}_1}{\partial \alpha_2} \cdot \mathbf{e}_2 = \frac{1}{A_1} \frac{\partial(A_2 \mathbf{e}_2)}{\partial \alpha_1} \cdot \mathbf{e}_2 - \frac{1}{A_1} \frac{\partial A_1}{\partial \alpha_2} \mathbf{e}_1 \cdot \mathbf{e}_2 = \frac{A_2}{A_1} \frac{\partial \mathbf{e}_2}{\partial \alpha_1} \cdot \mathbf{e}_2 + \frac{1}{A_1} \frac{\partial A_2}{\partial \alpha_1} \mathbf{e}_2 \cdot \mathbf{e}_2 = \frac{1}{A_1} \frac{\partial A_2}{\partial \alpha_1}$$

and also, by eq. (7.34)

$$\frac{\partial \mathbf{e}_1}{\partial \alpha_2} \cdot \mathbf{e}_3 = \frac{\partial(\mathbf{e}_1 \cdot \mathbf{e}_3)}{\partial \alpha_2} - \mathbf{e}_1 \cdot \frac{\partial \mathbf{e}_3}{\partial \alpha_2} = -\mathbf{e}_1 \cdot \frac{\partial \mathbf{e}_3}{\partial \alpha_2} = -\frac{A_2}{R_2} \mathbf{e}_1 \cdot \mathbf{e}_2 = 0.$$

The derivatives of \mathbf{e}_2 can be found in the same way and resumming, we have

$$\begin{aligned}
\frac{\partial \mathbf{e}_1}{\partial \alpha_1} &= -\frac{1}{A_2} \frac{\partial A_1}{\partial \alpha_2} \mathbf{e}_2 - \frac{A_1}{R_1} \mathbf{e}_3, \\
\frac{\partial \mathbf{e}_1}{\partial \alpha_2} &= \frac{1}{A_1} \frac{\partial A_2}{\partial \alpha_1} \mathbf{e}_2, \\
\frac{\partial \mathbf{e}_2}{\partial \alpha_1} &= \frac{1}{A_2} \frac{\partial A_1}{\partial \alpha_2} \mathbf{e}_1, \\
\frac{\partial \mathbf{e}_2}{\partial \alpha_2} &= -\frac{1}{A_1} \frac{\partial A_2}{\partial \alpha_1} \mathbf{e}_1 - \frac{A_2}{R_2} \mathbf{e}_3, \\
\frac{\partial \mathbf{e}_3}{\partial \alpha_1} &= \frac{A_1}{R_1} \mathbf{e}_1, \\
\frac{\partial \mathbf{e}_3}{\partial \alpha_2} &= \frac{A_2}{R_2} \mathbf{e}_2.
\end{aligned} \tag{7.37}$$

Passing now to the 2nd-order derivatives, imposing the equality of mixed derivatives, gives some important differential relations between the Lamé's parameters A_i and the radiuses of curvatures R_i . In fact, from the identity

$$\frac{\partial^2 \mathbf{e}_3}{\partial \alpha_1 \partial \alpha_2} = \frac{\partial^2 \mathbf{e}_3}{\partial \alpha_2 \partial \alpha_1},$$

and eqs. (7.37)_{5,6} we get

$$\frac{\partial}{\partial \alpha_2} \left(\frac{A_1}{R_1} \mathbf{e}_1 \right) = \frac{\partial}{\partial \alpha_1} \left(\frac{A_2}{R_2} \mathbf{e}_2 \right),$$

whence

$$\frac{\partial}{\partial \alpha_2} \left(\frac{A_1}{R_1} \right) \mathbf{e}_1 + \frac{A_1}{R_1} \frac{\partial \mathbf{e}_1}{\partial \alpha_2} = \frac{\partial}{\partial \alpha_1} \left(\frac{A_2}{R_2} \right) \mathbf{e}_2 + \frac{A_2}{R_2} \frac{\partial \mathbf{e}_2}{\partial \alpha_1}.$$

Injecting now eqs. (7.37)_{2,3} into the last result and rearranging the terms gives

$$\left[\frac{\partial}{\partial \alpha_2} \left(\frac{A_1}{R_1} \right) - \frac{1}{R_2} \frac{\partial A_1}{\partial \alpha_2} \right] \mathbf{e}_1 - \left[\frac{\partial}{\partial \alpha_1} \left(\frac{A_2}{R_2} \right) - \frac{1}{R_1} \frac{\partial A_2}{\partial \alpha_1} \right] \mathbf{e}_2 = 0,$$

that to be true needs that the two following conditions be identically satisfied:

$$\begin{aligned}
\frac{\partial}{\partial \alpha_2} \left(\frac{A_1}{R_1} \right) - \frac{1}{R_2} \frac{\partial A_1}{\partial \alpha_2} &= 0, \\
\frac{\partial}{\partial \alpha_1} \left(\frac{A_2}{R_2} \right) - \frac{1}{R_1} \frac{\partial A_2}{\partial \alpha_1} &= 0.
\end{aligned} \tag{7.38}$$

The above equations are known as the *Codazzi conditions*. Let us now consider the other identity

$$\frac{\partial^2 \mathbf{e}_1}{\partial \alpha_1 \partial \alpha_2} = \frac{\partial^2 \mathbf{e}_1}{\partial \alpha_2 \partial \alpha_1};$$

still using eq. (7.37), with some standard passages this identity can be transformed to

$$\left[\frac{\partial}{\partial \alpha_1} \left(\frac{1}{A_1} \frac{\partial A_2}{\partial \alpha_1} \right) + \frac{\partial}{\partial \alpha_2} \left(\frac{1}{A_2} \frac{\partial A_1}{\partial \alpha_2} \right) + \frac{A_1 A_2}{R_1 R_2} \right] \mathbf{e}_2 + \left[\frac{\partial}{\partial \alpha_2} \left(\frac{A_1}{R_1} \right) - \frac{1}{R_2} \frac{\partial A_1}{\partial \alpha_2} \right] \mathbf{e}_3 = 0.$$

Again, for this equation to be identically satisfied, each of the expressions in square brackets must vanish, which gives two further differential conditions, but only the first one is new, as the second one corresponds to eq. (7.38)₁. The new condition is hence

$$\frac{\partial}{\partial \alpha_1} \left(\frac{1}{A_1} \frac{\partial A_2}{\partial \alpha_1} \right) + \frac{\partial}{\partial \alpha_2} \left(\frac{1}{A_2} \frac{\partial A_1}{\partial \alpha_2} \right) + \frac{A_1 A_2}{R_1 R_2} = 0, \quad (7.39)$$

which is known as the *Gauss condition*. The last identity

$$\frac{\partial^2 \mathbf{e}_2}{\partial \alpha_1 \partial \alpha_2} = \frac{\partial^2 \mathbf{e}_2}{\partial \alpha_2 \partial \alpha_1}$$

does not add any further independent condition, as it can be easily checked. The meaning of the *Gauss-Codazzi conditions*, eqs. (7.38) and (7.39), is that of *compatibility conditions*: only when these conditions are satisfied by functions A_1, A_2, R_1 and R_2 , then such functions represent the Lamé's parameters and the principal radiuses of curvature of a surface, i.e. only in this case they define a surface, except for its position in space.

7.18 Exercices

1. Prove that a function of the type $x_3 = f(x_1, x_2)$, with $f : \Omega \subset \mathbb{R}^2 \rightarrow \mathbb{R}$ smooth, defines a surface.
2. Show that the catenoid is the rotation surface of a catenary, then find its Gaussian curvature.
3. Show that the pseudo-sphere is the rotation surface of a tractrix and explain why the surface has this name (hint: look for its Gaussian curvature).
4. Prove that the regularity of a cone is satisfied at each point exception made for the apex and for the points on straight lines tangent to $\boldsymbol{\gamma}(u)$.
5. Prove that the hyperbolic hyperboloid is a doubly ruled surface.
6. Prove that the hyperbolic paraboloid, whose Cartesian equation is $x_3 = x_1 x_2$, is a doubly ruled surface.
7. Consider the parameterization

$$\mathbf{f}(u, v) = (1 - v)\boldsymbol{\gamma}(u) + v\boldsymbol{\lambda}(u),$$

with

$$\boldsymbol{\gamma}(u) = (\cos(u - \alpha), \sin(u - \alpha), -1), \quad \boldsymbol{\lambda}(u) = (\cos(u + \alpha), \sin(u + \alpha), 1).$$

Show that:

- for $\alpha = 0$ one gets a cylinder with equation $x_1^2 + x_2^2 = 1$;
- for $\alpha = \frac{\pi}{2}$ one gets a cone with equation $x_1^2 + x_2^2 = x_3^2$;
- for $0 < \alpha < \frac{\pi}{2}$ one gets a hyperbolic hyperboloid with equation

$$\frac{x_1^2 + x_2^2}{\cos^2 \alpha} - \frac{x_3^2}{\cot^2 \alpha} = 1.$$

8. Calculate the first fundamental form of a sphere of radius R , determine the metric on it, the area of a sector of surface between the longitudes θ_1 and θ_2 and the length of the parallel at the latitude $\pi/4$ between these two longitudes.
9. Prove that the surface defined by

$$\mathbf{f}(u, v) : \Omega = \mathbb{R} \times (-\pi, \pi] \rightarrow \mathcal{E} \mid \mathbf{f}(u, v) = \left(\frac{\cos v}{\cosh u}, \frac{\sin v}{\cosh u}, \frac{\sinh u}{\cosh u} \right)$$

is a sphere; then show that the image of any straight line on Ω is a loxodromic line on the sphere.

10. Calculate the vectors of the natural basis, the first and second fundamental form and the tensors \mathbf{g} , \mathbf{X} , \mathbf{B} for the catenoid.
11. Make the same for the helicoid of parametric equation

$$\mathbf{f}(u, v) = \boldsymbol{\gamma}(u) + v\boldsymbol{\lambda}(u),$$

with

$$\boldsymbol{\gamma}(u) = (0, 0, u), \quad \boldsymbol{\lambda}(u) = (\cos u, \sin u, 0).$$

12. Show that the catenoid and the helicoid are made of hyperbolic points.
13. Determine the geodesic lines of a circular cylinder.

Suggested texts

There are many textbooks on tensors, differential geometry and calculus of variations. The style, content, language of such books greatly depends upon the scientific community the authors belong to: pure or applied mathematicians, theoretical mechanics or engineers. It is hence difficult to suggest some readings in the domain, in the end it is for a lot a matter of personal taste.

This manuscript is greatly inspired by some classical methods, style and language that are typical in the community of theoretical mechanics; the following few suggested readings among several possible other ones belong to such a kind of scientific literature. They are classical textbooks and though the list is far from being exhaustive, they constitute a solid basis for the topics shortly developed in this manuscript, where the objective is to make mathematics for mechanics.

A good introduction to tensor algebra and analysis, that greatly inspired the content of this manuscript, are the two introductory chapters of the classical textbook

- M. E. Gurtin: *An introduction to continuum mechanics*. Academic Press, 1981,

or also, in the same style, the long article

- P. Podio-Guidugli: *A primer in elasticity*. Journal of Elasticity, v. 58: 1-104, 2000.

A short, effective introduction to tensor algebra and differential geometry of curves can be found in the following text of exercices on analytical mechanics:

- P. Biscari, C. Poggi, E. G. Virga: *Mechanics notebook*. Liguori Editore, 1999.

A classical textbook on linear algebra to be recommended is

- P. R. Halmos: *Finite-dimensional vector spaces*. Van Nostrand Reynold, 1958.

In the previous textbooks, tensor algebra in curvilinear coordinates is not developed; an introduction to this topic, specially intended for physicists and engineers, can be found in

- W. H. Müller: *An expedition to continuum theory*. Springer, 2014,

that has largely influenced Chapter 6.

Two modern and application oriented textbooks on differential geometry of curves and surfaces are

- V. A. Toponogov: *Differential geometry of curves and surfaces - A concise guide*. Birkhäuser, 2006,
- A. Pressley: *Elementary differential geometry*. Springer, 2010.

A short introduction to the differential geometry of surfaces, oriented to the mechanics of shells, can be found in the classical book

- V. V. Novozhilov: *Thin shell theory*. Noordhoff LTD., 1964.

For what concerns the calculus of variations, a still valid textbook in the matter (and not only) is

- R. Courant, D. Hilbert: *Methods of mathematical physics*. Interscience Publishers, 1953.

Two very good and classical textbooks with an introduction to the calculus of variations for mechanicians are

- C. Lanczos: *The variational principles of mechanics*. University of Toronto Press, 1949,
- H. L. Langhaar: *Energy methods in applied mechanics*. Wiley, 1962.