



HAL
open science

Graph-based Pattern Detection in Spatio-Temporal Phenomena

Kamaldeep Singh Oberoi, Géraldine del Mondo

► **To cite this version:**

Kamaldeep Singh Oberoi, Géraldine del Mondo. Graph-based Pattern Detection in Spatio-Temporal Phenomena. 16th Spatial Analysis and Geomatics Conference (SAGEO 2021), May 2021, La Rochelle (virtuel), France. hal-03232523

HAL Id: hal-03232523

<https://hal.science/hal-03232523>

Submitted on 21 May 2021

HAL is a multi-disciplinary open access archive for the deposit and dissemination of scientific research documents, whether they are published or not. The documents may come from teaching and research institutions in France or abroad, or from public or private research centers.

L'archive ouverte pluridisciplinaire **HAL**, est destinée au dépôt et à la diffusion de documents scientifiques de niveau recherche, publiés ou non, émanant des établissements d'enseignement et de recherche français ou étrangers, des laboratoires publics ou privés.

Graph-based Pattern Detection in Spatio-Temporal Phenomena

Kamaldeep Singh Oberoi, Géraldine Del Mondo

Normandie Univ, INSA Rouen, LITIS, 76000, Rouen (France)
kamal.oberoi@insa-rouen.fr,geraldine.del_mondo@insa-rouen.fr

RÉSUMÉ. *Les modèles spatio-temporels (ST) sont souvent utilisés pour analyser les phénomènes ST. Une de ces techniques d'analyse consiste à détecter des motifs dans le phénomène pour comprendre son évolution et modéliser le comportement de ses entités dans l'espace et le temps. Dans cet article, nous nous concentrons sur l'utilisation d'une représentation fondée sur les graphes dynamiques pour la modélisation des phénomènes ST, au sein duquel des motifs structurels, également modélisés sous forme de graphes dynamiques, peuvent être détectés. Nous illustrons le concept de motif par deux exemples applicatifs - le trafic routier et les sports collectifs. Pour chacun d'eux, nous présentons une modélisation du graphe ainsi que des motifs associés. Ensuite, nous formalisons le problème de la détection de motifs comme celui de l'isomorphisme de sous-graphe pour les graphes dynamiques. Enfin, nous présentons les résultats de notre algorithme pour résoudre ce problème. Les premiers résultats décrits dans cet article, qui sont obtenus en utilisant les graphes aléatoires, présentent une base de référence pour les futurs tests de l'algorithme.*

ABSTRACT. *Spatio-temporal (ST) models are often used for analyzing ST phenomena. One such analysis technique is to detect patterns in the phenomenon to understand its evolution and model the behaviour of its entities over space-time. In this paper, we focus on using a dynamic graph-based representation for modeling ST phenomena, within which structural patterns, also modeled using dynamic graphs, can be detected. We illustrate the concept of pattern using two applications - road traffic and invasive team sports. For both these applications, we present the graph model as well as the corresponding patterns. Then we formalize the problem of pattern detection as that of subgraph isomorphism for dynamic graphs. Finally, we present the results of our algorithm to solve this problem. The initial results described in this paper, obtained using random graphs, present a baseline for the future tests of the algorithm.*

MOTS-CLÉS : *Modélisation spatio-temporelle, Graphes dynamiques, Isomorphisme de sous-graphe, Trafic routier, Sports collectifs*

KEYWORDS: *Spatio-temporal modeling, Dynamic graphs, Subgraph isomorphism, Road traffic, Invasive team sports*

1. Introduction

The field of Spatio-Temporal (ST) Modeling has seen a growing interest in the last decades, most notably in the development of Geographical Information Science (GIS). GISystems store and analyze data about real-world entities, highlighting their ST evolution as well as the evolution of the overall phenomenon. Taking Leibnizian point of view, the real-world entities act as the basic units of space. In fact, space is defined in terms of the relations between such entities (Chrisman, 1977). From a conceptual point of view, these distinct entities and their time-varying spatial relations represent the ST phenomenon. This point of view leads to the development of a graph model of the phenomenon (Batty, 2003), where the nodes of the graph correspond to the entities and its edges represent the spatial relations between them. With this approach, the evolution of the phenomenon and its entities is explained in terms of the evolution of the graph, i.e., by modeling change in the attributes of the nodes and the edges and by modeling change in its overall structure. This evolution of the graph makes the temporal dimension of the model explicit. Such a modeling approach has been used for modeling dynamics of street networks (Costes *et al.*, 2015), for describing topological relations between places and events (Maduako, Wachowicz, 2019), etc. in the literature.

Representing the structure of the phenomenon using a graph encourages the development of analysis techniques which exploit the structural properties of the phenomenon. In other words, using this methodology, graph algorithms can be directly applied to analyse the characteristics of the phenomenon. One such analysis technique is the graph-based pattern detection. Pattern detection, in general, is useful to analyse the evolution or the behaviour of the entities of the phenomenon. Depending on the context, patterns might represent the evolution of environmental data (Tsoukatos, Gunopulos, 2001), spatio-temporal proximity of trajectories of moving objects (Demšar, Virrantaus, 2010) etc. However, in these cases, since the representation of the phenomenon does not take into account its underlying structure, the patterns detected are based on the quantitative data acquired about the phenomenon. Such patterns are called *statistical patterns* since statistical techniques are used for their definition and detection. When the underlying structure of the phenomenon is modeled, the concept of *structural patterns* comes into picture. Such patterns take a qualitative modeling approach and are defined in terms of the distinct entities and their corresponding relations which make up the ST phenomenon.

In this paper, we consider the notion of structural patterns and describe a method for their detection in ST phenomena. First, we consider two applications - urban road traffic and invasive team sports (specifically Handball) - to demonstrate the conceptual idea behind the structural patterns within a phenomenon. In case of road traffic, the patterns represent the movement of dynamic entities, like vehicles and pedestrians, and in case of handball, they represent predefined *plays* of the attacking team. The considered ST phenomena

(road traffic and handball) as well as the structural patterns are modeled using dynamic graphs with time-varying edge sets. For now, we do not consider the change in the attributes of the nodes or the edges.

Next, we describe the problem of pattern detection in a ST phenomenon in terms of the well known problem of *subgraph isomorphism (SI)* in graph theory, where a given *pattern graph* has to be detected in a given *target graph*. SI has been well studied in case of static pattern and target graphs (cf. (Conte *et al.*, 2004)). However, we are currently developing an algorithm to extend it for dynamic pattern and target graphs. In this paper, without going into details of the algorithm, we will present some initial results in terms of its runtime, which were computed using random dynamic pattern and target graphs. By using random graphs, we were able to modify various graph parameters, for both pattern and target graphs, to formalize the performance of our algorithm. The results presented in this paper provide us with a baseline which will be helpful when the algorithm will be applied to real data about different ST phenomena in the future.

The paper is organised as follows. Section 2 presents the related work. In Section 3, we will describe the graph model for representing road traffic and discuss different kinds of structural traffic patterns which can be defined using this model. In Section 4, we follow the same plan and discuss structural patterns in a game of handball. In Section 5, we formalize the problem of SI in case of dynamic graphs and then discuss the initial results of our algorithm. Lastly, Section 6 concludes the paper and discusses the future work.

2. Related work

Graphs have been used to model different kinds of spatial and spatio-temporal phenomena for the last two decades. However, an interesting point of discussion is the type of analysis that has been done using such graph representations. For example, (B. Jiang *et al.*, 2000) proposed a graph representation, called connectivity graph, to model the spatial structure of a building, using which graph parameters, like *node degree*, were applied for developing a cognitive point of view of space. Similarly, graph representations have been used to model street networks to understand the topological structure of the network and the *centrality* or the importance of a given street (Porta *et al.*, 2006).

Incorporating temporal information in the graph model leads to the definition of temporal version of graph parameters. For example, in (Del Mondo *et al.*, 2010), the authors have proposed a spatio-temporal graph model for representing ST phenomena. Since time is incorporated in the graph in terms of its time-varying structure, the neighborhood of a node is time-dependent. The authors have used the term *spatio-temporal neighborhood* to describe the neighbors of a node at a given instant (spatial) or during an interval (temporal). Using this notion, the authors are able to model the propagation of

brambles through space-time. Furthermore, for understanding the propagation of a disease within a population, it is important to note the contacts between different people over time. This idea has been applied in (Shirani-Mehr *et al.*, 2012) where a dynamic contact network is used to analyze the propagation of a virus. The authors study *reachability queries* which verify if a path exists between two nodes of the graph. But since the graph is time-varying, the path between two nodes evolves over time.

Graph-based pattern detection is also a very well studied research field. Some existing research focuses on frequent pattern mining, where the pattern is not known *a priori* and a subgraph which exists a certain number of times is considered pertinent (C. Jiang *et al.*, 2013). Moreover, detecting a given pattern graph in a given target graph also has its particular applications (Conte *et al.*, 2004). However, detection of dynamic patterns in dynamic graphs is not very matured research area. With this paper, we want to, first, highlight the semantics behind dynamic graph-based patterns in different spatio-temporal phenomena and, second, formalize the problem of pattern detection as that of subgraph isomorphism for dynamic graphs. The experiments performed on random graphs outline the performance of our algorithm.

3. Structural patterns in urban road traffic

In this section, we consider the case of urban road traffic. We will first describe, in brief, the formalization of the graph model representing traffic and semantics behind its nodes and edges and then discuss some examples of structural traffic patterns.

3.1. Graph-based model of road traffic

In our previous work (Oberoi *et al.*, 2017), a graph for representing urban road traffic was proposed. One of the objectives of this work was to understand the behaviour of dynamic entities of traffic (vehicles and pedestrians) under different traffic situations. As a result, we developed a traffic model which takes into account not only dynamic but static entities (buildings, traffic signs, road markings, footpaths, road segments, intersections) as well which affect traffic flow. In addition, the interactions between these entities, in terms of spatial relations between them (like topological, orientation, relative trajectory, relative speed, qualitative distance etc.), were also considered. The entities constituting traffic were represented as the nodes and the relations between them were represented as its edges. Given that traffic is a dynamic phenomenon, the model incorporated the temporal dimension as well. The proposed model had the support for snapshot-based approach, where each graph snapshot represented the state of the road traffic at a given time instant. Hence, the evolution of the graph, and in turn of road traffic, was described by a set of distinct graph snapshots for a given period of time. The model represents the behaviour of dynamic

entities in terms of their movement and their interactions with other entities over time. Given that the evolution of traffic is described using a set of distinct graph snapshots, the movement of dynamic entities can also be modeled using the same methodology. This defines the semantics behind the structural traffic patterns discussed below.

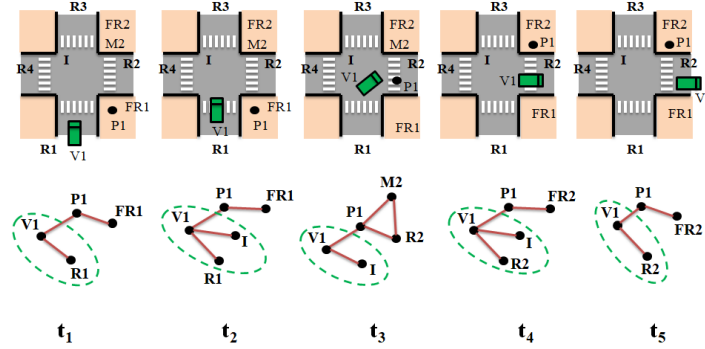

FIGURE 1. Pattern representing the movement of a vehicle and a pedestrian

3.2. Structural traffic patterns

Here, we present two examples of structural traffic patterns describing the movement of a vehicle and/or a pedestrian and their interactions with other entities over time. It is noteworthy that in the model proposed in (Oberoi *et al.*, 2017) edges represent spatial relations between entities but for defining the structural patterns we do not explicitly consider any spatial relations and focus only on the time-varying graph structure.

3.2.1. Vehicle crossing an intersection

A basic traffic situation is that of a vehicle crossing an intersection (the green encircled part of the graphs in Figure 1). In this situation, we consider five graph snapshots which represent the location of the vehicle $V1$ at a given instant. When the vehicle is on a road segment (at times t_1 , t_2 , t_4 and t_5), an edge between the vehicle and the corresponding road segment node ($R1$ or $R2$) exists in those graph snapshots. At t_3 , the vehicle is on the intersection I , hence, there is an edge between the vehicle and the intersection nodes. At times t_2 and t_4 , the vehicle is shared between the road segment and the intersection.

3.2.2. Vehicle crossing an intersection while pedestrian crossing a street

This situation combines the movement of the pedestrian $P1$ with that of the vehicle $V1$ (Figure 1). At time t_1 , the pedestrian is on the footpath $FR1$ and

the vehicle is approaching the intersection. The vehicle waits for the pedestrian at time t_3 and once the pedestrian has crossed the street, the vehicle continues moving at time t_4 . The road marking (zebra crossing) is represented as $M2$. This example highlights the fact that the movement of dynamic entities gets affected due to the presence of other entities around them and this effect can be represented using the structural representation of road traffic.

4. Structural patterns in team sports

In the literature, invasive team sports have been represented using graphs to model player interactions (Gudmundsson, Horton, 2017). In this section, while focusing on the game of handball, we will describe a graph modeling approach which takes into account the "role" of the players as well as their positions on the playing field. Then we will describe two examples of predefined plays for the attacking team, modeled using dynamic graphs. Such predefined actions could represent spatio-temporal patterns in other team sports as well.

4.1. Graph-based model for handball

We are working on developing a graph model to represent the game of handball while taking into account the role of each player and their corresponding positions for both defending and attacking teams. For the attacking team, there are six roles: Left and Right Backcourt, Center Backcourt, Left and Right Wingers and Pivot. For the defending team, there are seven roles (six defenders and one goal keeper) and we consider "6-0" defending formation. In addition, we consider two zones on the court which describe the position of each player. Free Throw ("FT") zone represents the area between the six meter line and the free throw line whereas Nine metre ("9m") zone represents the area beyond the free throw line towards the middle of the court. These two zones are added as nodes in the graph which has a total of seventeen nodes, fourteen corresponding to the player roles, one representing the ball and two for the zones.

The edges between "role" nodes represent the proximity relation, i.e., two players of same or opposite teams are connected if they are close to each other. The exact distance value to define the relation between two role nodes is not yet fixed. An edge between a role and the ball node represents the possession of the ball by the player having that role. The ball node could also be connected to two role nodes representing the action of pass between corresponding players. And finally, an edge between a role and zone node represents the topological relation between the player and the zone. It is added to represent the position of the player on the court. As in the case of road traffic, this graph represents the underlying structure of the game by describing player interactions. It is evident that this graph evolves with time and its evolution can be modeled in terms of its time-varying structure. The progress of the game is represented as

a set of discrete states of the graph. Such a graph model can be used to model and extract the predefined actions of the attacking team as discussed below.

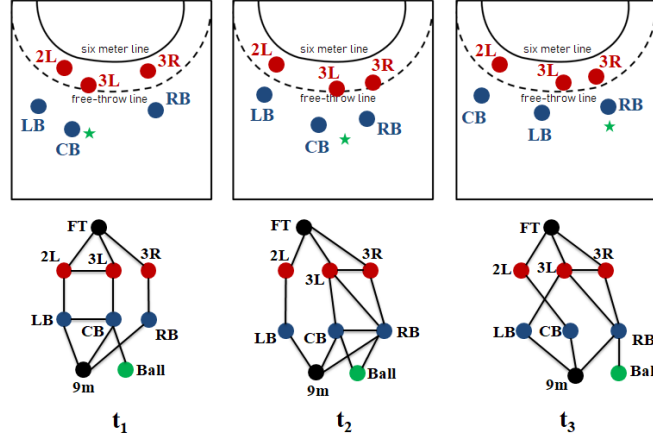

FIGURE 2. Switch between *CB* and *LB* players in the attacking team (in blue). The defending team is in red and the green star represents the ball

4.2. Structural patterns in handball

Similar to road traffic, structural patterns representing player actions in handball can be defined and modeled using dynamic graphs.

4.2.1. Switch between Center Backcourt and Left Backcourt

This tactic involves the players with roles of Center Backcourt *CB*, Left Backcourt *LB* and Right Backcourt *RB* in the attacking team (Figure 2). The tactic begins when Center Backcourt is in the possession of the ball at time t_1 . Then the ball is passed to the Right Backcourt at time t_2 . Then Center Backcourt takes the place of Left Backcourt and Left Backcourt takes the place of Center Backcourt leaving Right Backcourt with the ball possession at time t_3 . Then, according to the game situation, Right Backcourt may pass the ball or take the shot. Here, the roles of Right and Left Backcourt players can be interchanged.

4.2.2. Crossover between Center Backcourt and Right Backcourt

Here, the Center Backcourt and the Right Backcourt are involved in the action. The tactic begins when Center Backcourt is in the possession of the ball at time t_1 . He/she runs towards the direction of the Right Backcourt and Right Backcourt runs towards the middle of the playing field. When they are

close enough, the Center Backcourt makes a pass to the Right Backcourt at time t_2 , leaving Right Backcourt with the ball possession at time t_3 . Then, depending on the situation, Right Backcourt either shoots or makes another pass. The same action can also be performed by Center and Left Backcourt players as well.

5. Pattern detection in ST phenomena

In Sections 3 and 4, we described the graph-based approach for modeling road traffic and invasive team sports respectively. In both cases, the global phenomenon was modeled using a dynamic (target) graph within which some pertinent patterns, also modeled using dynamic (pattern) graphs, could be detected. In this section, we will formalize the problem of pattern detection as that of subgraph isomorphism (SI). First, we will formally define the problem and then present initial results of the algorithm under development to solve SI in case of dynamic pattern and target graphs.

5.1. Problem formulation

Consider a static graph $G = (X, E, \psi)$ with a set of nodes X and set of edges $E \subset X \times X$. Node classification function $\psi : X \rightarrow C$ assigns a class to each node from a set of classes C . It is possible for two nodes to belong to the same class. For example, in case of road traffic a node class could mean Vehicle, Road marking etc. whereas in case of handball a node class could mean Zone, Player of the attacking team etc. In addition, unique node labels are assigned to each node. Given a pair of static pattern graph $H = (X_H, E_H, \psi_H)$ and static target graph $G = (X_G, E_G, \psi_G)$, the problem of SI is to find an injective mapping $\mu \subset X_H \times X_G$ between the nodes of both graphs, while respecting the following conditions:

$$\forall u \in X_H, \exists v \in X_G \mid (u, v) \in \mu \quad (1)$$

$$\forall u, u' \in X_H, u \neq u', \exists \{(u, v), (u', v')\} \in \mu \Rightarrow v \neq v' \quad (2)$$

$$\forall (u, u') \in E_H, \exists (v, v') \in E_G \quad (3)$$

$$\forall u, u' \in X_H, (v, v') \in E_G, \{(u, v), (u', v')\} \in \mu \Rightarrow (u, u') \in E_H \quad (4)$$

$$\forall u \in X_H, \exists (u, v) \in \mu \Rightarrow \psi_H(u) = \psi_G(v) \quad (5)$$

Equations 1 and 2 state that all distinct nodes of the H must be mapped to some (but distinct) nodes of G . Equation 3 states that all edges of H are mapped to some edges of G . Equation 4 verifies the "induced" version of SI by checking that a mapped edge of G has a corresponding edge in H , i.e., the subgraph of G matched with H has no extra edges. Lastly, equation 5 states that only the nodes belonging to the same class in both H and G are mapped.

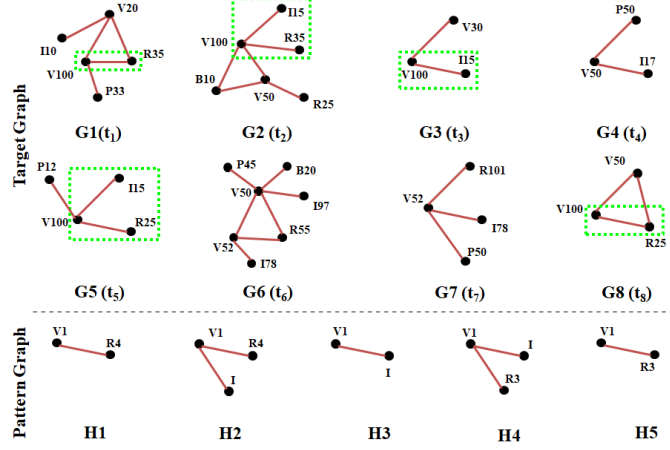

FIGURE 3. Snapshots of target graph \mathcal{G} and pattern graph \mathcal{H} with detected pattern highlighted in \mathcal{G} . Set of nodes in both graphs remains constant over time but the isolated nodes are not shown for better readability

Next, we define a simple dynamic graph $\mathcal{G} = (X_{\mathcal{G}}, E_{\mathcal{G}}, \mathcal{T}_{\mathcal{G}}, \psi_{\mathcal{G}})$ as a graph whose set of edges $E_{\mathcal{G}}$ is time-varying. Its discrete time domain $\mathcal{T}_{\mathcal{G}}$ is represented as a set of time instants $\mathcal{T}_{\mathcal{G}} = \{t_1, t_2, \dots, t_k\}$. We consider a snapshot-based model where a graph snapshot G_i at time instant t_i represents its state. Following this, a dynamic graph can be represented as a set of its discrete states, i.e., $\mathcal{G} = \{G_1, G_2, \dots, G_k\}$ (Figure 3).

Given a pair of dynamic pattern graph $\mathcal{H} = \{H_1, H_2, \dots, H_m\}$, having m snapshots, and dynamic target graph $\mathcal{G} = \{G_1, G_2, \dots, G_n\}$, having n snapshots, with $m \leq n$, we extend the problem of SI for dynamic graphs, i.e., (1) Each snapshot of \mathcal{H} must be mapped to some snapshot of \mathcal{G} while respecting the conditions of subgraph isomorphism (Equations 1-5). (2) The time order of \mathcal{H} and \mathcal{G} must be respected, i.e., if a snapshot $H_i, 1 \leq i \leq m$ of \mathcal{H} is mapped to a snapshot $G_j, 1 \leq j \leq n$ of \mathcal{G} , then the next snapshot H_{i+1} of \mathcal{H} must be mapped to some snapshot G_f of \mathcal{G} where $f > j$. (3) To find a complete matching of \mathcal{H} , a node $v \in X_{\mathcal{H}}$ must be mapped to the same node $v' \in X_{\mathcal{G}}$ at every time instant where the matching is possible and both nodes v and v' exist. (4) It is possible to have some snapshots of \mathcal{G} to which no snapshots of \mathcal{H} are matched. Such snapshots represent *noise*. They are included to be realistic in terms of the sampling rate to generate the target graphs in real applications. In Figure 3, the node classes are represented by the first character of their unique labels, i.e., the node having label $V20$ belongs to the class V etc. The pattern and target graph snapshots are matched as follows: $H1 \rightarrow G1$, $H2 \rightarrow G2$, $H3 \rightarrow G3$, $H4 \rightarrow G5$ and $H5 \rightarrow G8$, while the nodes of the pattern graph are

matched as: $V1 \rightarrow V100$, $R4 \rightarrow R35$, $I \rightarrow I15$ and $R3 \rightarrow R25$. Some target graph snapshots (G_4 , G_6 and G_7) represent "noise".

5.2. Experiments and results

We are developing an algorithm which takes graphs \mathcal{H} and \mathcal{G} as input and detects all instances of \mathcal{H} in \mathcal{G} . Our algorithm is based on another algorithm, VF3 (Carletti *et al.*, 2018), which has been developed for static pattern and target graphs. We extend VF3 to include the temporal order for both graphs. We have tested our algorithm using 6050 random pattern and target graph pairs which were generated with different values of graph parameters - Size (N), Density (D), Number of node classes (C) and Number of snapshots (T), while making sure that at least one instance of the pattern graph exists in the corresponding target graph. We calculated the average runtime and standard deviation (SD) for fifty graph pairs with different values of each parameter, while considering the total time taken, excluding, however, the time required to load each graph from the files. Some of the results obtained are tabulated in Table 1. For denser target graphs, the average runtime increases. This is due to the fact that for denser target graphs, the number of possible node mappings to be verified is higher. Similarly, increasing the number of snapshots of the target graph, the runtime increases since algorithm performs more iterations to find the solution. Increasing, however, the number of node classes of the target graph does not have a significant effect on the average runtime. For denser pattern graphs, the runtime also increases since it takes more time to look for the corresponding edges in the target graph to satisfy the equations 3 and 4 (Section 5.1). Increasing the number of snapshots of the pattern graph shows a peculiar behaviour. The runtime keeps increasing with the increase in the number of pattern snapshots since more graphs have to be mapped to find the complete solution. However, when the number of pattern snapshots becomes equal to the number of target snapshots ($T_t = T_p = 100$ in this case) the algorithm terminates quickly. This is due to the fact that the steps required to look for a future snapshot of the target graph are not performed in this case since a snapshot H_i of the pattern graph gets mapped to the snapshot G_i of the target graph. Similarly to target graph, increasing the number of node classes of the pattern graph does not have any significant effect on the runtime.

6. Conclusion and future work

The objective of this paper is to show the applicability of qualitative graph-based representations for modeling ST phenomena. Graphs represent the underlying structure of the phenomenon which can be exploited to analyse its spatio-temporal evolution. We focused on detecting patterns within different phenomena. Taking the examples of road traffic and handball, we highlighted the conceptual idea of structural pattern and then formalized the problem of

TABLE 1. Avg. runtime and standard deviation for different graph parameters

Pattern Graph				Target Graph				Runtime	SD
N_p	C_p	D_p	T_p	N_t	C_t	D_t	T_t	(secs)	(secs)
30	20	0.8	30	700	20	0.2	30	0.15	0.02
30	20	0.8	30	700	20	0.3	30	0.15	0.016
30	20	0.8	30	700	20	0.4	30	0.34	0.06
30	20	0.8	10	700	20	0.3	30	0.63	0.08
30	20	0.8	10	700	20	0.3	60	1.43	0.16
30	20	0.8	10	700	20	0.3	100	2.57	0.3
30	20	0.8	30	700	5	0.3	30	0.14	0.015
30	20	0.8	30	700	10	0.3	30	0.13	0.013
30	20	0.8	30	700	20	0.3	30	0.15	0.016
100	20	0.4	30	300	20	0.3	30	0.71	0.033
100	20	0.6	30	300	20	0.3	30	0.76	0.032
100	20	0.8	30	300	20	0.3	30	0.82	0.034
100	20	0.4	30	300	20	0.3	100	28.02	1.23
100	20	0.4	60	300	20	0.3	100	58.55	2.6
100	20	0.4	100	300	20	0.3	100	2.43	0.12
100	5	0.4	30	300	20	0.3	30	0.71	0.031
100	10	0.4	30	300	20	0.3	30	0.72	0.033
100	20	0.4	30	300	20	0.3	30	0.71	0.034

pattern detection as that of subgraph isomorphism for dynamic graphs. Finally, the results of our algorithm applied to random dynamic graphs were discussed. The next step would be to apply our algorithm on the real data. In fact, we have generated structural traffic patterns using a traffic simulator and we are in the process of applying our algorithm on the generated traffic model. For the case of Handball, the graph has been generated for a single game using video sequences and we are at the stage of defining pertinent structural patterns.

Acknowledgements

The authors would like to thank François Rioult, Quentin Bourgeois and Jeffrey Girault for providing the data for handball and for multiple discussions related to the detection of predefined plays in handball as part of NormaSTIC Federation.

Bibliographie

Batty M. (2003). Network geography: Relations, interactions, scaling and spatial processes in gis. *Centre for Advanced Spatial Analysis Working Paper Series*, p. 63:1-63:23.

- Carletti V., Foggia P., Saggese A., Vento M. (2018, April). Challenging the time complexity of exact subgraph isomorphism for huge and dense graphs with VF3. *IEEE Transactions on Pattern Analysis and Machine Intelligence*, vol. 40, n° 4, p. 804-818.
- Chrisman N. (1977). Concepts of space as a guide to cartographic data structures. In *First international advanced study symposium on topological data structures for geographic information systems*.
- Conte D., Foggia P., Sansone C., Vento M. (2004). Thirty years of graph matching in pattern recognition. *International Journal of Pattern Recognition and Artificial Intelligence*, vol. 18, n° 03, p. 265-298.
- Costes B., Perret J., Bucher B., Gribaudo M. (2015). An aggregated graph to qualify historical spatial networks using temporal patterns detection. In *18th agile international conference on geographic information science*.
- Del Mondo G., Stell J. G., Claramunt C., Thibaud R. (2010). A graph model for spatio-temporal evolution. *Journal of Universal Computer Science*, vol. 16, n° 11, p. 1452-1477.
- Demšar U., Virrantaus K. (2010). Space-time density of trajectories: exploring spatio-temporal patterns in movement data. *International Journal of Geographical Information Science*, vol. 24, n° 10, p. 1527-1542.
- Gudmundsson J., Horton M. (2017, avril). Spatio-temporal analysis of team sports. *ACM Comput. Surv.*, vol. 50, n° 2.
- Jiang B., Claramunt C., Klarqvist B. (2000). Integration of space syntax into gis for modelling urban spaces. *International Journal of Applied Earth Observation and Geoinformation*, vol. 2, n° 3, p. 161 - 171.
- Jiang C., Coenen F., Zito M. (2013). A survey of frequent subgraph mining algorithms. *The Knowledge Engineering Review*, vol. 28, n° 1, p. 75-105.
- Maduako I., Wachowicz M. (2019). A space-time varying graph for modelling places and events in a network. *International Journal of Geographical Information Science*, vol. 33, n° 10, p. 1915-1935.
- Oberoi K. S., Del Mondo G., Dupuis Y., Vasseur P. (2017). Towards a qualitative spatial model for road traffic in urban environment. In *2017 IEEE 20th international conference on intelligent transportation systems*, p. 1724-1729. IEEE.
- Porta S., Crucitti P., Latora V. (2006). The network analysis of urban streets: A primal approach. *Environment and Planning B: Planning and Design*, vol. 33, n° 5, p. 705-725.
- Shirani-Mehr H., Banaei-Kashani F., Shahabi C. (2012). Efficient reachability query evaluation in large spatiotemporal contact datasets. *Proc. VLDB Endow.*, vol. 5, n° 9, p. 848-859.
- Tsoukatos I., Gunopulos D. (2001). Efficient mining of spatiotemporal patterns. In C. S. Jensen, M. Schneider, B. Seeger, V. J. Tsotras (Eds.), *Advances in spatial and temporal databases*, p. 425-442. Springer Berlin Heidelberg.