



**HAL**  
open science

## Raman Laser Spectrometer: Application to $^{12}\text{C}/^{13}\text{C}$ Isotope Identification in $\text{CH}_4$ and $\text{CO}_2$ Greenhouse Gases

Vladimir Vitkin, Anton Polishchuk, Ian Chubchenko, Evgeniy Popov, Konstantin Grigorenko, Artem Kharitonov, Arsen Davtian, Anton Kovalev, Valeria Kurikova, Patrice Camy, et al.

► **To cite this version:**

Vladimir Vitkin, Anton Polishchuk, Ian Chubchenko, Evgeniy Popov, Konstantin Grigorenko, et al.. Raman Laser Spectrometer: Application to  $^{12}\text{C}/^{13}\text{C}$  Isotope Identification in  $\text{CH}_4$  and  $\text{CO}_2$  Greenhouse Gases. Applied Sciences, 2020, 10 (21), pp.7473. 10.3390/app10217473 . hal-03215887

**HAL Id: hal-03215887**

**<https://hal.science/hal-03215887>**

Submitted on 7 Oct 2021

**HAL** is a multi-disciplinary open access archive for the deposit and dissemination of scientific research documents, whether they are published or not. The documents may come from teaching and research institutions in France or abroad, or from public or private research centers.

L'archive ouverte pluridisciplinaire **HAL**, est destinée au dépôt et à la diffusion de documents scientifiques de niveau recherche, publiés ou non, émanant des établissements d'enseignement et de recherche français ou étrangers, des laboratoires publics ou privés.

1 Article

# 2 Raman laser spectrometer: Application to $^{12}\text{C}/^{13}\text{C}$ 3 isotope identification in $\text{CH}_4$ and $\text{CO}_2$ greenhouse 4 gases

5 Vladimir Vitkin <sup>1</sup>, Anton Polishchuk <sup>1</sup>, Ian Chubchenko <sup>1</sup>, Evgeniy Popov <sup>1</sup>, Konstantin  
6 Grigorenko <sup>1</sup>, Artem Kharitonov <sup>1</sup>, Arsen Davtian <sup>1</sup>, Anton Kovalev <sup>1</sup>, Valeria Kurikova <sup>1</sup>, Patrice  
7 Camy <sup>2</sup>, Pavel Loiko <sup>2</sup>, Magdalena Aguiló <sup>3</sup>, Francesc Díaz <sup>3</sup> and Xavier Mateos <sup>3,\*</sup>

8 <sup>1</sup> ITMO University, 49 Kronverksky Pr., 197101 St. Petersburg, Russia; e-mail: v.v.v@bk.ru

9 <sup>2</sup> Centre de Recherche sur les Ions, les Matériaux et la Photonique (CIMAP), UMR 6252 CEA-CNRS-  
10 ENSICAEN, Université de Caen, 6 Boulevard du Maréchal Juin, 14050 Caen, France

11 <sup>3</sup> Universitat Rovira i Virgili (URV), Física i Cristal·lografia de Materials i Nanomaterials (FiCMA-FiCNA)-  
12 EMaS, Marcel·li Domingo 1, 43007 Tarragona, Spain

13 \* Correspondence: xavier.mateos@urv.cat

14 Received: date; Accepted: date; Published: date

15 **Featured Application:** The developed Raman laser gas spectrometer is suitable for detection of  
16 carbon isotopologues of methane and carbon dioxide in human exhalation.

17 **Abstract:** A compact Raman laser gas spectrometer is developed. It comprises a high-power green  
18 laser at 532.123 nm as an excitation source and a specially designed gas cell with an internal volume  
19 less than 0.6 cm<sup>3</sup> withstanding gas pressures up to 100 atm. The resolution of the spectrometer is  
20 ~1 cm<sup>-1</sup>. The Raman spectra of chemically pure isotopically enriched carbon dioxide ( $^{12}\text{CO}_2$ ,  $^{13}\text{CO}_2$ )  
21 and methane ( $^{12}\text{CH}_4$ ,  $^{13}\text{CH}_4$ ) gases are studied. The expected limit of detection (LOD) is less than  
22 100 ppm for the isotopologues of  $\text{CO}_2$  and less than 25 ppm for those of  $\text{CH}_4$  (at a gas pressure of  
23 50 atm.), making the developed spectrometer promising for studying the sources of emissions of  
24 greenhouse gases by resolving their isotopologue composition. We also show the suitability of the  
25 spectrometer for Raman spectroscopy of human exhalation.

26 **Keywords:** Raman laser spectrometer; carbon isotopes; greenhouse gases; carbon dioxide; methane;  
27 human exhalation.  
28

## 29 1. Introduction

30 Nowadays, the concentration of greenhouse gases (such as  $\text{CO}_2$ ,  $\text{CH}_4$ ,  $\text{N}_2\text{O}$ , etc.) in the  
31 atmosphere is increasing due to the anthropogenic emissions. Thus, there is a need to determine the  
32 anthropogenic contribution against the natural background and to recognize emissions from various  
33 industries [1-3]. One possibility for doing this is via the carbon isotope ( $^{12}\text{C}$  and  $^{13}\text{C}$ ) ratio  
34 measurements of carbon dioxide ( $\text{CO}_2$ ) and methane ( $\text{CH}_4$ ) in the atmospheric air [4,5].

35 So far, the isotope ratio Raman spectroscopy of  $\text{CO}_2$  was addressed in several research works. In  
36 [6], the authors have found a way for determining the isotope-delta values (the relative difference of  
37 isotope ratios with respect to the reference material)  $\delta^{13}\text{C}$  using micro-Raman spectroscopy. A  
38 technique for monitoring  $^{13}\text{CO}_2$  by cavity-enhanced Raman spectroscopy was developed in [7].  
39 Quantitative analysis of carbon isotopic composition in  $\text{CO}_2$  with the estimation of the measurement  
40 uncertainty was performed in [8]. A detailed experimental and theoretical study on isotopic surface-  
41 enhanced Raman Spectroscopy was done in [9].

42 Defining the isotopic composition of greenhouse gases helps to constrain global budgets and to  
43 study sink and source processes [10]. CH<sub>4</sub> is an important anthropogenic and natural greenhouse gas  
44 and, moreover, it participates in atmospheric chemistry through its reaction with the hydroxyl radical  
45 [11]. Since individual CH<sub>4</sub> sources have characteristic isotope signatures, carbon and hydrogen  
46 isotope ratios of CH<sub>4</sub> (e.g., δ<sup>13</sup>C - CH<sub>4</sub>) have been useful to constrain the global methane budget [12].

47 By precisely measuring the ratio of <sup>13</sup>C to <sup>12</sup>C, one is able to determine the source of methane  
48 [13]. The individual values depend on the mechanisms of the CH<sub>4</sub> formation and consumption prior  
49 to its release to the atmosphere. It was shown [14] that it is possible to accurately measure the methane  
50 content in natural gases using Raman spectroscopy. The results of this work show the possibility of  
51 isotope-ratio analysis of methane.

52 Nowadays, isotope ratio measurement systems based on optical spectrometers are used because  
53 of several advantages. The first one is the fundamental possibility to distinguish the isotopologues  
54 (molecules that differ only in their isotope composition) with the same molecular weight but different  
55 isotopic composition like <sup>16</sup>O<sup>13</sup>C<sup>16</sup>O and <sup>16</sup>O<sup>12</sup>C<sup>17</sup>O (both representing carbon dioxide) [15]. Second, it  
56 is possible to perform calibration-free absolute measurement of isotopologues based on *ab initio*  
57 calculations of line intensities [16]. This is a relevant possibility in the metrology of isotope ratios  
58 because the International Committee for Weights and Measures (CIPM) encourages the development  
59 of absolute isotope ratio measurement values for reference materials [17]. Third, such systems are  
60 relatively easy in use, field deployable and low cost. They require no complicated sample  
61 preparation, provide real-time data, and allow for *in situ* monitoring with a spectroscopic selectivity.  
62 The disadvantage of the isotope ratio optical spectrometers compared to mass spectrometers is still  
63 low accuracy [18].

64 Raman spectroscopy has advantages over traditional methods in the analysis of pure  
65 isotopologues. Due to different selection rules, Raman spectroscopy can detect even diatomic  
66 homonuclear molecules such as O<sub>2</sub> or N<sub>2</sub> [19-22]. The development of Raman-based gas analyzers  
67 was presented in several papers [23,24]. A system for analysis of mixtures of CO and H<sub>2</sub> (synthesis  
68 gas) was proposed in [25]. The Purcell enhanced Raman scattering (PERS) device was used for  
69 isotopic gas analysis in [26]. A Raman analyzer for sensitive natural gas composition analysis was  
70 described in [27]. The main limitation is the low intensity of Raman scattering from gases. So far,  
71 application of Raman spectroscopy for routine trace gas analysis have not found widespread use due  
72 to the inherent weakness of Raman transitions and it was mainly employed in condensed phases [28].  
73 The above mentioned limitation can be overcome by using intense excitation beams and high-  
74 pressure gas cavities. For the reliable <sup>13</sup>C/<sup>12</sup>C ratio measurements, it is critical to calibrate the  
75 instruments. The preparation of calibration gas mixtures requires the analysis of the parent gases,  
76 such as pure <sup>12</sup>CO<sub>2</sub> and <sup>13</sup>CO<sub>2</sub> [29].

77 In the present work, we report on the method of quantitative analysis of <sup>12</sup>CO<sub>2</sub>, <sup>13</sup>CO<sub>2</sub>, <sup>12</sup>CH<sub>4</sub> and  
78 <sup>13</sup>CH<sub>4</sub> greenhouse gases based on Raman laser gas spectroscopy.

## 79 2. Materials and Methods

80 This study is dedicated to the development of a compact Raman laser gas spectrometer suitable  
81 for the analysis of gases under high pressures. The details of the spectrometer are described in  
82 Section 3.

83 The isotopically enriched carbon dioxide (<sup>12</sup>CO<sub>2</sub>, <sup>13</sup>CO<sub>2</sub>) and methane (<sup>12</sup>CH<sub>4</sub> and <sup>13</sup>CH<sub>4</sub>) gases  
84 were studied. The CO<sub>2</sub> gases were provided by PA EXP, Ltd. (Russia) and the CH<sub>4</sub> ones – by the  
85 Cambridge Isotope Laboratories (USA). The chemical purity (CP) and carbon isotopic enrichment  
86 (δC) of the studied gases are specified in Table 1 (provided by the suppliers). The chemical purity  
87 shows the molar content of the main gas component and equals to 100% minus the total content of  
88 impurities (e.g., N<sub>2</sub>, O<sub>2</sub>, Ar, CO, etc.). It is measured by gas chromatography–mass spectrometry (GC-  
89 MS). The carbon isotopic enrichment shows the content of the target isotopologue in the main gas  
90 component and it is measured by isotope-ratio mass spectrometry (IRMS). The gas temperature was  
91 293 K.

92 **Table 1.** Chemical purity (CP) and Carbon isotopic enrichment ( $\delta C$ ) of the studied carbon dioxide  
 93 and methane gases.

Gas	CP, %	$\delta C$ , %
$^{12}\text{CO}_2$	>99.987	99.992
$^{13}\text{CO}_2$	>99.994	99.57
$^{12}\text{CH}_4$	>99.5	>99.99
$^{13}\text{CH}_4$	>99	>99.9

94 This work also includes the study of human exhalation. All subjects gave their informed consent  
 95 for inclusion before they participated in the study. The study was conducted in accordance with the  
 96 Declaration of Helsinki, and the protocol was approved by the Ethics Committee of ITMO University  
 97 (project RFMEFI57518X0180).

### 98 3. Raman laser spectrometer

#### 99 3.1. Excitation source

100 The scheme of the spectrometer is shown in Fig. 1. As the excitation source, we employed a  
 101 continuous-wave diode-pumped solid-state laser (MSL-R-532, CNI-Lasers) emitting ~5 W of linearly  
 102 polarized output at a wavelength of 532.123 nm with a full-angle divergence of 1.5 mrad, the beam  
 103 quality parameter  $M^2_{x,y} < 1.1$  (TEM<sub>00</sub> mode) and a laser linewidth of <1 pm (~0.03 cm<sup>-1</sup>). The excitation  
 104 beam was expanded using a  $\times 7$  Vega laser beam expander ( $\lambda = 532$  nm, Edmund Optics) and focused  
 105 into the gas cell using a specially designed doublet lens with a focal length  $f = 55.9$  mm with both  
 106 sides antireflection (AR) coated at 532 nm. The measured spot size in the focus was less than 10  $\mu\text{m}$   
 107 (diameter, as measured by the optical knife method). The peak on-axis laser intensity was then about  
 108 ~10 MW/cm<sup>2</sup>. More details about the focusing system can be found elsewhere [30].

109 Prior to the beam expanding system, we installed a system based on a pair of crossed polarizers  
 110 (P1 and P2) and a  $\lambda/2$  waveplate and a Faraday rotator placed between them. It prevented back-  
 111 scattered light from damaging the excitation laser. In addition, a pair of flat highly-reflective (HR)  
 112 mirrors was used to align precisely the focal spot position in the gas cell, Fig. 1(b).

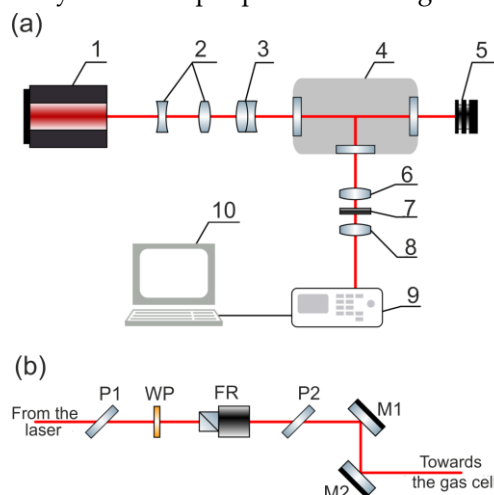

113

114 **Figure 1.** (a) Scheme of the Raman gas spectrometer: 1 – excitation laser, 2 – lens expander, 3 – focusing  
 115 lens, 4 – gas cell, 5 – laser radiation absorber, 6 – collecting lens, 7 – notch filter, 8 – focusing lens,  
 116 9 – spectrometer, 10 – computer; (b) System for attenuation and optical alignment of the laser beam:  
 117 P1 and P2 – polarizers, WP – half-wave plate, M1, M2 – HR mirrors.

#### 118 3.2. High-pressure gas cell

119 A special gas cell made of titanium was developed, Fig. 2. It was designed to work with gases in  
 120 a limited volume with high pressure. The internal volume was only 0.57 cm<sup>3</sup>. To prevent reflections  
 121 and light scattering, the internal surfaces of the gas cell were coated with an anti-glare enamel. The

122 two optical windows for the excitation and scattered beams were made of K8 optical glass. The  
 123 detection was at  $90^\circ$  to the optical axis of the laser beam. The gas cell can withstand pressures up to  
 124  $\sim 100$  atm. Note that  $\text{CO}_2$  passes from the gaseous to liquid phase at a pressure of  $\sim 60$  atm.

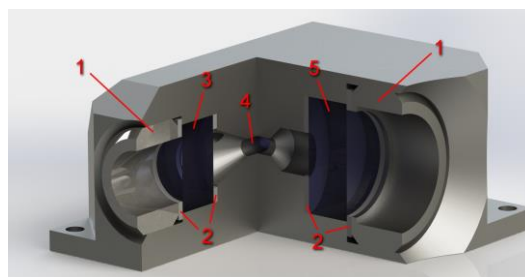

125

126 **Figure 2.** The scheme of the high-pressure gas cell: 1 – nut rings, 2 - PTFE gaskets, 3 – input window  
 127 for passing the excitation light, 4 – useful volume for the studied gas, 5 – output window for collection  
 128 of the scattered light.

129 The thickness of the optical windows was determined based on the calculations of the stress and  
 130 displacement fields in the windows using the SolidWorks software, Fig. 3(a)-(d). The ultimate stress  
 131 for both windows was assumed to be below the elastic limit of the K8 glass,  $\sim 40$  MPa, Fig. 3(e). Under  
 132 these conditions, the minimum thickness of the windows is 8 mm with a deviation from flatness of  
 133  $2 \mu\text{m}$  when exposed to a pressure of 100 atm. We have selected the thickness of 8 mm for both  
 134 windows. The clear aperture (diameter) of the windows was  $\sim 10$  mm (for the excitation beam) and  
 135 15 mm (for the scattered light). The input window was AR coated for 532 nm and the output one –  
 136 for 420-680 nm. The calculated fraction of the collected Raman signal determined by the geometry of  
 137 the gas cell is 11%.

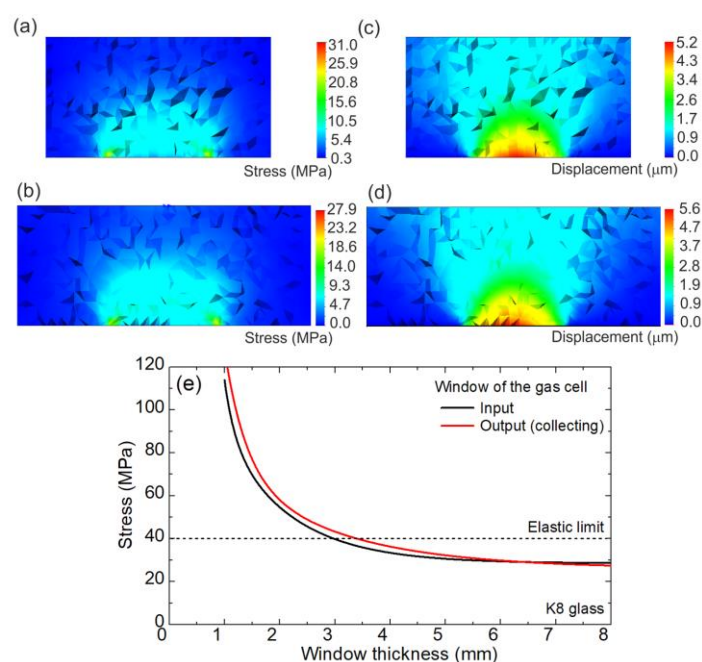

138

139 **Figure 3.** (a)-(d) Simulation of (a),(b) the stress field,  $\sigma$ , and (c),(d) the field of total displacements,  $u$ ,  
 140 in (a),(c) the input window of the gas cell and (b),(d) the output window used for collection of the  
 141 scattered light. The gas pressure is 100 atm; (e) Calculated maximum stress in the window *vs.* its  
 142 thickness, the dashed line represents the elastic limit of the K8 glass (the window material). The grain  
 143 structure in (a)-(d) represents the mesh used in the simulations.

144 The gas cell was equipped with a gas inlet and an outlet. First, a backing vacuum pump was  
 145 connected to the outlet valve and the cell was evacuated to the pressure of  $10^{-3}$  mm Hg. Then, the

146 inlet valve was opened and the cell was filled in with the studied or reference gas. After the  
147 measurement, we released the gas into the evacuation system through the outlet valve.

### 148 3.3. Spectrometer

149 The scattered light was collected using an achromatic doublet lens ( $f = 55.9$  mm) AR-coated for  
150 420-680 nm. The Rayleigh scattered light was filtered out using a pair of notch filters (attenuation at  
151 532 nm:  $\times 10^{-12}$ ). Another achromatic doublet lens ( $f = 80.6$  mm) was used to reimage the scattered light  
152 at the input slit of the spectrometer. It had the same AR coating as for the collecting lens.

153 The spectrometer was based on a Czerny-Turner scheme. A diffraction grating with 1800  
154 grooves per mm with a blazing wavelength of 500 nm was used. Its spectral efficiency at 330-860 nm  
155 exceeded 40%. The linear dispersion of the system was 1.52 nm/mm and the spectral resolution (the  
156 instrumental linewidth, full width at half maximum (FWHM)) was 0.05 nm. The reproducibility of  
157 the wavelength setting was 0.03 nm. To find a compromise between the spectral resolution and the  
158 signal-to-noise (SNR) ratio, the width of the entrance slit was  $\sim 20$   $\mu\text{m}$  during the experiments. For  
159 detecting the spectra, we used a CMOS camera (Hamamatsu) with a 2048 $\times$ 122 pixel<sup>2</sup> grid (pixel size:  
160 12 $\times$ 12  $\mu\text{m}$ ). It was cooled by a Peltier element to  $-40$   $^{\circ}\text{C}$ . The exposure time varied from 10  $\mu\text{s}$  up to  
161 10 min. The projected spectral range was as long as 35 nm (0.017 nm per pixel). It was possible to shift  
162 this range within the interval 530-635 nm. More details can be found in [31].

163 The wavelength grading was performed using an Hg-He arc-discharge spectral lamp (DRGS-  
164 12). The calibration of the Raman spectrometer was performed using a certified reference material of  
165 toluene with a known Raman spectrum [32]. The determined relative standard deviation ( $\Delta_{\text{rel}}$ )  
166 between the measured and standard peak Raman shifts of toluene was  $<0.01\%$  for the range of Raman  
167 shifts of 1000-3300  $\text{cm}^{-1}$  (for  $\lambda_{\text{exc}} = 532.123$  nm). The spectral resolution of the spectrometer was  $\sim 1$   $\text{cm}^{-1}$   
168 (the instrumental linewidth, FWHM). The measurements are performed at room temperature (293  
169 K).

## 170 4. Spectroscopy of $^{12}\text{C}/^{13}\text{C}$ isotopologues

171 The study of greenhouse gas mixtures containing the gases of interest (i.e., carbon dioxide and  
172 methane) requires a preliminary study of the reference gases with high chemical and isotopic purity.

173 The Raman spectra of the carbon isotopologues of carbon dioxide and methane are known. Here,  
174 we briefly describe and interpret the measured spectra.

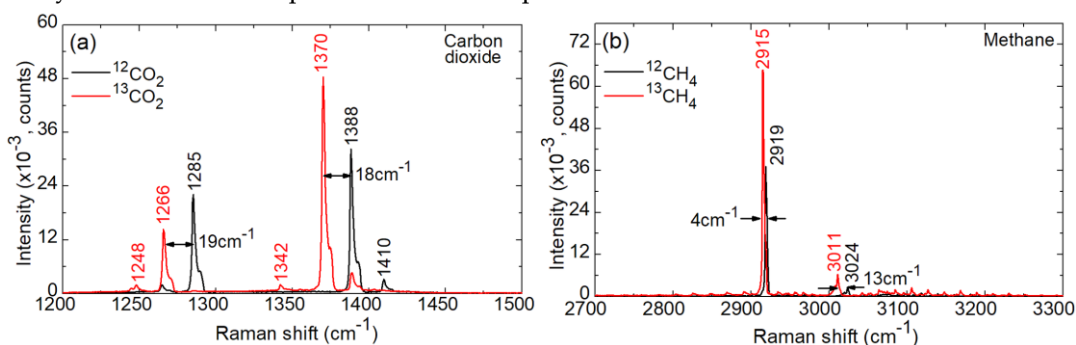

175

176 **Figure 4.** Raman spectra of isotopically enriched (a) carbon dioxide ( $^{12}\text{CO}_2$  and  $^{13}\text{CO}_2$ ) and (b) methane  
177 ( $^{12}\text{CH}_4$  and  $^{13}\text{CH}_4$ ) gases. The excitation wavelength  $\lambda_{\text{exc}} = 532.123$  nm; the resolution is  $\sim 1$   $\text{cm}^{-1}$ . Gas  
178 pressure: 1 atm. Exposure time: 60 s.

179 The  $\text{CO}_2$  molecule is linear and centrosymmetric. The Raman spectrum of  $\text{CO}_2$ , see Fig. 4(a),  
180 contains two intense and sharp Q-branches which form the diad  $\nu_1$  (1388 / 1370  $\text{cm}^{-1}$ ) and  $2\nu_2$  (1285 /  
181 1266  $\text{cm}^{-1}$ ) for the  $^{12}\text{C} / ^{13}\text{C}$  containing molecules, respectively [33]. Adjacent to these lines, there are  
182 much weaker ones assigned as  $\nu_1 + \nu_2 - \nu_2$  (1410  $\text{cm}^{-1}$  for  $^{12}\text{C}$ , for  $^{13}\text{C}$ , it overlaps with the  $\nu_1$  line) and  
183  $3\nu_2 - \nu_2$  (1266 / 1248  $\text{cm}^{-1}$  for  $^{12}\text{C} / ^{13}\text{C}$ , respectively). The easiest attribution of the carbon isotopologues  
184 of  $\text{CO}_2$  is according to the  $\nu_1$  and  $2\nu_2$  diad: the wavenumber shift between the corresponding lines for

185 the  $^{12}\text{CO}_2$  and  $^{13}\text{CO}_2$  molecules is  $\sim 18\text{--}19\text{ cm}^{-1}$ . The Raman lines of isotopologues of carbon dioxide are  
 186 easily detectable even at low gas pressure (1 atm.) using isotopically-enriched gases.

187 The Raman spectra of the  $^{12}\text{CH}_4$  isotopologue have been systematically studied. Much less  
 188 information is present about the second most abundant natural isotopologues,  $^{13}\text{CH}_4$  [34]. Only  
 189 recently, several studies focused on filling in this gap [35].  $\text{CH}_4$  has tetrahedral symmetry (point group  
 190  $T_d$ ) with four normal modes of vibration. They are labeled by irreducible representations of the  $T_d$   
 191 point group. The fundamental frequencies exhibit a simple relation,  $\nu_1(A_1) \approx \nu_3(F_2) \approx 2\nu_2(E) \approx 2\nu_4(F_2)$ .  
 192 It leads to the so-called polyad structure in the Raman and IR spectra [36]. A polyad  $P_n$  gathers all  
 193 vibrational states ( $\nu_1, \nu_2, \nu_3$  and  $\nu_4$ ) satisfying the condition  $n = 2(\nu_1 + \nu_3) + \nu_2 + \nu_4$ , where  $\nu_i$  are the  
 194 vibrational quantum numbers for  $i$ -th ( $i = 1, 2, 3, 4$ ) mode. Each set of  $\{\nu_i\}$  defines a vibrational level.  
 195 The pentad  $P_2$  corresponds to 5 vibrational levels:  $2\nu_4, \nu_2 + \nu_4, 2\nu_2, \nu_1$  and  $\nu_3$ . The lines in the Raman  
 196 spectra corresponding to the pentad of methane are observed at  $\sim 3000\text{ cm}^{-1}$  and they can be used for  
 197 detection of isotopologues of  $\text{CH}_4$ .

198 The Raman spectra of isotopologues of methane around  $\sim 3000\text{ cm}^{-1}$  have a rich structure due to  
 199 the complex vibration-rotation polyad interaction. The most intense line is observed at  $\sim 2919\text{ cm}^{-1}$   
 200 ( $^{12}\text{CH}_4$ ) and  $2915\text{ cm}^{-1}$  ( $^{13}\text{CH}_4$ ) and is assigned as  $\nu_1$ . The isotope wavenumber shift is only  $\sim 4\text{ cm}^{-1}$ . This  
 201 line is well detected even at low gas pressure and short exposure, Fig. 4(b). Other prominent lines are  
 202 those at  $\sim 3024\text{ cm}^{-1}$  ( $^{12}\text{CH}_4$ ) and  $3011\text{ cm}^{-1}$  ( $^{13}\text{CH}_4$ ) showing higher isotope wavenumber shift whilst  
 203 much lower intensity.

204 The spectra from Fig. 4 were analyzed to determine the limit of detection (LOD) for each of the  
 205 gases, Table 2. First, the Raman intensity at the characteristic Raman shift ( $\nu$ ) was determined both  
 206 for the signal ( $I_{\text{signal}}$ ) and noise ( $I_{\text{noise}}$ ) yielding the useful signal,  $\Delta I_{\text{signal}} = I_{\text{signal}} - I_{\text{noise}}$ . The room mean  
 207 square value of the noise, (r.m.s.) $_{\text{noise}}$ , was also determined. The noise analysis was performed using  
 208 the spectra of isotopically enriched gases in the wavenumber range free of Raman lines covering  
 209 about  $\sim 1000\text{ cm}^{-1}$ . The LOD is:

$$\text{LOD}_{\text{vol}\%} = X_{\text{vol}\%} \frac{3(\text{r.m.s.})_{\text{noise}}}{\Delta I_{\text{signal}}} \quad (1)$$

210 Here,  $X_{\text{vol}\%}$  is the volume fraction of the studied gas which is close to 100% for chemically pure  
 211 isotopically enriched gases, cf. Table 1. The results on LOD are shown in Table 2 being expressed  
 212 both in vol% and parts per million (ppm),  $\text{LOD}_{\text{ppm}} = 10^4 \times \text{LOD}_{\text{vol}\%}$ .

213 The upper limit for the error in the LOD estimation was determined by analyzing 10 repetitive  
 214 measurements for the  $^{12}\text{CH}_4$  gas. The maximum deviation from the average LOD value was  $\sim 14\%$ .

215 **Table 2.** Analysis<sup>a</sup> of the Sensitivity of the Raman Gas Spectrometer According to the Study of  
 216 Chemically Pure Isotopically Enriched Carbon Dioxide and Methane Gases

Parameter	$^{12}\text{CO}_2$	$^{13}\text{CO}_2$	$^{12}\text{CH}_4$	$^{13}\text{CH}_4$
$\nu, \text{cm}^{-1}$	1388	1370	2919	2915
$I_{\text{signal}}, \text{counts}$	7630	13754	37487	64654
$I_{\text{noise}}, \text{counts}$	382	229	523	311
(r.m.s.) $_{\text{noise}}, \text{counts}$	28	27	30	28
$\Delta I_{\text{signal}}, \text{counts}$	7248	13525	36964	64343
LOD(1 atm.), %	1.1731	0.5952	0.2428	0.1303
LOD(50 atm.), %	<i>0.0227</i>	<i>0.0119</i>	<i>0.0049</i>	<i>0.0026</i>
LOD(50 atm.), ppm	227	119	49	26
LOD(50 atm., 300 s), ppm	95	50	20	11

217 <sup>a</sup>The Raman spectra are shown in Fig. 4, gas pressure: 1 atm., exposure time: 60 s.  
 218 The estimated LOD values for the pressure of 50 atm. are according to Fig. 5. The  
 219 error in the specified LOD values is 14%. The estimated values are given in *italics*.

220 The LOD can be decreased in two ways. One is the increase of the gas pressure. The limit of  
 221 detection is proportional to inverse of the gas pressure  $p$ ,  $\text{LOD} \sim 1/p$ , see Eq. (1). Indeed, the useful  
 222 Raman signal of a gas is proportional to the gas pressure [37], while the noise level is mostly

223 determined by the detector and thus is independent on the pressure. To confirm this, we have  
 224 measured the Raman spectra of chemically pure isotopically enriched  $^{12}\text{CO}_2$  gas at various gas  
 225 pressures in the range of 1 – 9 atm. keeping the same exposure time of 60 s. The resulting LOD values  
 226 (according to the  $1388\text{ cm}^{-1}$  Raman line) are shown in Fig. 5. The data agree well with the  $\text{LOD} \sim 1/p$   
 227 law, yielding an estimation of the limit of detection at the maximum available gas pressure (50 atm.)  
 228 of 227 ppm (for 60 s exposure). Note that particularly for  $\text{CO}_2$  at high pressures (>50 atm.), it was  
 229 pointed out in [10] that the exponential law better describes the dependence of the Raman signal on  
 230 the gas pressure. Further studies are thus required at such elevated pressures.

231 Using the data measured at 1 atm., we interpolated the dependences for other gases, as shown  
 232 in Fig. 5 by dashed lines. The corresponding  $\text{LOD}(50\text{ atm.})$  values are listed in Table 2. In particular,  
 233 for methane, they are as low as 49 ppm ( $^{12}\text{CH}_4$ ) and 26 ppm ( $^{13}\text{CH}_4$ ).

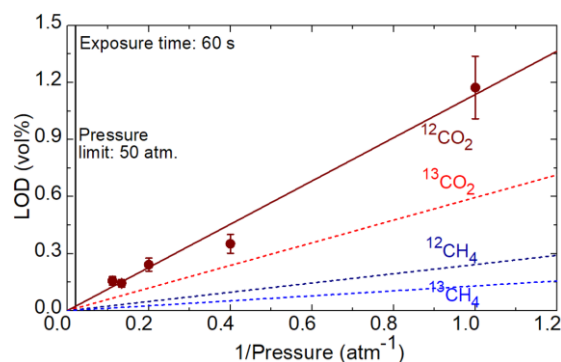

234

235 **Figure 5.** Limit of detection (LOD) of chemically pure isotopically enriched carbon dioxide and  
 236 methane gases *vs.* inverse of the gas pressure: *symbols:* experimental data for  $^{12}\text{CO}_2$  using the  $1388\text{ cm}^{-1}$   
 237 Raman line, *solid line* – their linear fit, *dashed lines* – interpolation for other gases according to the  
 238 measurement at 1 atm. Exposure time: 60 s.

239 Another possible way to improve the LOD is to increase the exposure time whilst this approach  
 240 is of limited use for applications where relatively fast characterization is needed. As an example, we  
 241 studied the  $^{13}\text{CH}_4$  gas at a fixed pressure of 1 atm. and an exposure time  $\Delta t$  in the range of 1-60 s. The  
 242 Raman spectra obtained for  $\Delta t = 1\text{--}30\text{ s}$  are presented in Fig. 6(a). Longer exposures allow observing  
 243 weak spectral details of the  $^{13}\text{CH}_4$  pentad.

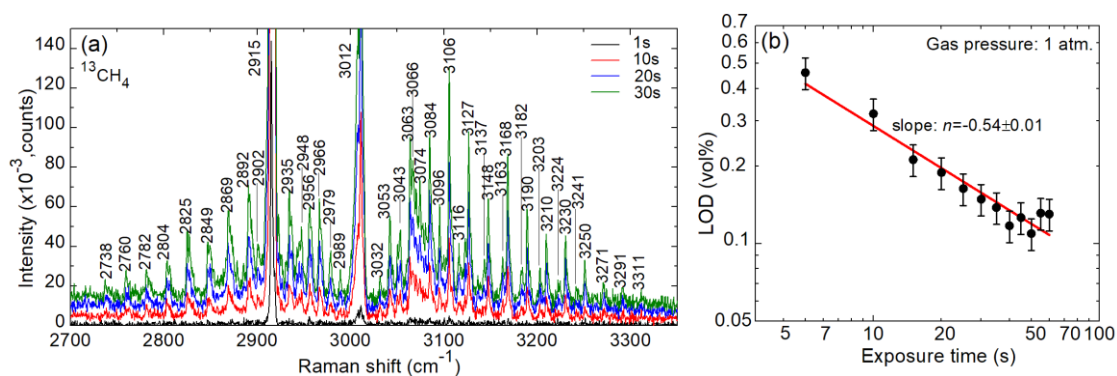

244

245 **Figure 6.** (a) Raman spectrum of high-purity (>99%) isotopically-enriched (>99.9%  $^{13}\text{C}$ )  $^{13}\text{CH}_4$  gas. The  
 246 excitation wavelength  $\lambda_{\text{exc}} = 532.123\text{ nm}$ ; the resolution is  $\sim 1\text{ cm}^{-1}$ . Gas pressure: 1 atm. Exposure time  
 247  $\Delta t$ : 1 – 30 s; (b) Double-logarithmic plot of LOD *vs.* the exposure time: *symbols:* experimental data, *line:*  
 248 linear fit according to Eq. (2). Gas pressure: 1 atm.

249 The dependence of LOD on the exposure time  $\Delta t$ , plotted in a double-logarithmic scale, is shown  
 250 in Fig. 6(b). From statistics, it is known that the r.m.s. of an average value is reduced by a factor of  
 251  $N^{-0.5}$  with respect to that for a single measurement, where  $N$  is the number of measurements which  
 252 are averaged. Thus, if  $\Delta t_0 = 1\text{ s}$  measurement yields a limit of detection of  $\text{LOD}_0$ , any longer



253 measurement with  $\Delta t = s \times \Delta t_0$  can be represented as a set of  $s$  elementary measurements with  
 254  $\text{LOD}(\Delta t) = \text{LOD}_0 \times s^{-0.5} = \text{LOD}_0 \times (\Delta t / \Delta t_0)^{-0.5}$ . By plotting Fig. 6(b) in double-logarithmic scale and fitting  
 255 the experimental points by a linear function, we obtain the slope  $n$  of the dependence:

$$\text{LOD}(\Delta t) = \text{LOD}_0 \left( \frac{\Delta t}{\Delta t_0} \right)^{-n} \quad (2)$$

256 In our case,  $n = -0.54 \pm 0.01$  which agrees well with the theoretical considerations.

257 By considering both the effects of the increased gas pressure ( $p = 50$  atm.) and the exposure time  
 258 ( $\Delta t = 300$  s), we obtained lower-limit estimations of LOD for all four studied gases, cf. Table 2, i.e.,  
 259  $<100$  ppm for the isotopologues of carbon dioxide and  $<25$  ppm for those of methane.

## 260 5. Towards applications: Human exhalation

261 Raman spectroscopy is well suited for the simultaneous detection of various gases in the analysis  
 262 of human respiration [38]. Natural carbon isotopes ( $^{12}\text{C}$  and  $^{13}\text{C}$ ) present in the human breath can be  
 263 used to identify various diseases. Carbon isotopes in exhaled  $\text{CO}_2$  can be a valuable real time  
 264 biomarker of cachexia [39] (depletion of the body), associated with the acute phase of the reaction  
 265 caused by endotoxemia (accumulation of toxic substances in the body). The acute phase reaction  
 266 causes shifts in stable carbon isotopes in exhaled  $\text{CO}_2$ , which can be used to monitor nutrient  
 267 metabolism. Isotope mass spectrometry (IRMS) exists to determine  $\text{CO}_2$  carbon isotopes in human  
 268 respiration [40]. This method has high accuracy, sensitivity and stability, but it is rather complex,  
 269 expensive and requires large expenditures on equipment and staff training. There is a less expensive  
 270 way to detect  $\text{CO}_2$  isotopes using an isotope-selective non-dispersive infrared spectrometer (NDIRS)  
 271 [41], but it is only suitable for simple breath tests where a small number of samples are required, for  
 272 example, to detect diseases of the gastrointestinal tract and detect *Helicobacter pylori* [42].  
 273 This is due to a decrease in the correlation of repeated measurements with longer series of  
 274 measurements.

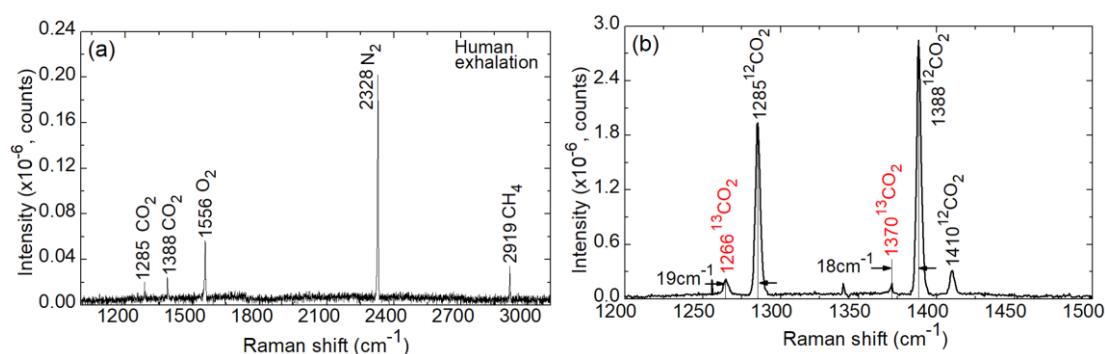

275

276 **Figure 7.** Raman spectrum of the human breath (exhalation): (a) an overview spectrum; (b) a close  
 277 view on the  $^{12}\text{CO}_2$  /  $^{13}\text{CO}_2$  lines. The excitation wavelength  $\lambda_{\text{exc}} = 532.123$  nm; the resolution is  $\sim 1$   $\text{cm}^{-1}$ .  
 278 Gas pressure: 1 atm. Exposure time: (a) 30 s, (b) 600 s.

279 An overview Raman spectrum of a human exhalation measured at ambient pressure (1 atm.) is  
 280 shown in Fig. 7(a). It shows several intense Raman peaks at 1285 and 1388  $\text{cm}^{-1}$  (both  $^{12}\text{CO}_2$ ),  
 281 1556  $\text{cm}^{-1}$  ( $\text{O}_2$ ), 2328  $\text{cm}^{-1}$  ( $\text{N}_2$ ) and 2919  $\text{cm}^{-1}$  ( $^{12}\text{CH}_4$ ). By focusing on the spectral range around  
 282  $\sim 1300$   $\text{cm}^{-1}$  and applying longer exposure (600 s), we were able to resolve clearly the Raman lines  
 283 assigned to the isotopologues of carbon dioxide ( $^{12}\text{CO}_2$  and  $^{13}\text{CO}_2$ ). The spectral position of the lines  
 284 and the isotopic wavenumber shifts well agree with the data for isotopically enriched gases, cf. Fig. 4.

285 The Raman spectra of isotopologues of carbon dioxide were analyzed from the point of view of  
 286 LOD in order to confirm the values obtained with the isotopically enriched gases, see Fig. 4. Note  
 287 that LOD can be calculated for any gas in a gas mixture if its volume fraction  $X_{\text{vol}\%}$  is known, see  
 288 Eq. (1). The volume fractions of  $^{12}\text{CO}_2$  and  $^{13}\text{CO}_2$  gases in the human exhalation depends on different  
 289 factors, e.g., on the time between breathing in and out [43,44]. We will use the mean values of 4 vol%

290  $^{12}\text{CO}_2$  and 0.04 vol%  $^{13}\text{CO}_2$ . Based on these volume fractions and the measured Raman spectra,  
291 Fig. 7(b), we have determined LOD to be 225 ppm ( $^{12}\text{CO}_2$ ) and 75 ppm ( $^{13}\text{CO}_2$ ) at a gas pressure of  
292 1 atm. and an exposure time of 600 s. These values agree well with the analysis performed in Table 2  
293 considering the difference in the exposure time.

## 294 6. Conclusions

295 To conclude, we have developed a sensitive and compact Raman laser spectrometer suitable for  
296 analyzing gas mixtures containing such relevant greenhouse gases as carbon dioxide and methane.  
297 In particular, it is capable of identifying the contributions of carbon isotopologues, such as  $^{12}\text{CO}_2$  /  
298  $^{13}\text{CO}_2$  and  $^{12}\text{CH}_4$  /  $^{13}\text{CH}_4$ . The feature of the developed spectrometer is a specially designed gas cell  
299 with the following advantages: (i) it can withstand high gas pressures (up to 100 atm.), (ii) it has a  
300 relatively small internal volume of  $\sim 0.6\text{ cm}^3$  relaxing the requirements for sample preparation, and  
301 (iii) together with the optical scheme of the spectrometer, it ensures good collection efficiency for the  
302 scattered light and, thus, low limits of detection (LODs) for the studied gases. By studying  
303 isotopically-enriched  $^{12}\text{CO}_2$  /  $^{13}\text{CO}_2$  and  $^{12}\text{CH}_4$  /  $^{13}\text{CH}_4$  gases, we estimated easily accessible LODs of  
304 less than 100 ppm for the isotopologues of carbon dioxide and less than 25 ppm for those of methane.  
305 We also show the proof-of-the-concept of the suitability of the developed spectrometer for studying  
306 the human exhalation.

307 Further work will focus on developing a gas analyzer using calibrated gas mixtures. Such Raman  
308 gas spectrometer and gas analyzer are promising for studies of sources of pollution in the  
309 atmosphere, combustion processes and human exhalation.

310 Potentially, the developed Raman gas spectrometer can be used for analyzing virus structures  
311 in human exhalation.

### 312 Author Contributions:

313 Conceptualization and methodology, E.P., I.C., A.Kh., P.C. and P.L.; validation, A.P. and A.D.; formal analysis,  
314 V.K.; investigation, V.V., I.C., E.P., A.P., A.D. and V.K.; data curation, A.K.; writing—original draft preparation,  
315 I.C., K.G.; writing—review and editing, P.L., M.A. and F.D.; visualization, K.G. and V.K.; supervision, V.V.;  
316 project administration, V.V. and X.M.; funding acquisition, V.V. All authors have read and agreed to the  
317 published version of the manuscript.

318 **Funding:** This research was funded by Ministry of Education and Science of Russian Federation, grant number  
319 RFMEFI57518X0180.

320 **Conflicts of Interest:** The authors declare no conflict of interest.

## 321 References

- 322 1. Rieker, G.B.; Giorgetta, F.R.; Swann, W.C.; Kofler, J.; Zolot, A.M.; Sinclair, L.C.; Baumann, E.; Cromer, C.;  
323 Petron, G.; Sweeney, C.; Tans, P.P.; Coddington, I.; Newbury, N.R. Frequency-comb-based remote sensing  
324 of greenhouse gases over kilometer air paths. *Optica* **2014**, *1*, pp. 290–298, doi: 10.1364/OPTICA.1.000290.
- 325 2. Ghosh, P.; Brand, W.A. Stable isotope ratio mass spectrometry in global climate change research. *Intern. J.*  
326 *Mass Spectrom.* **2003**, *228*, pp. 1–33, doi: 10.1016/S1387-3806(03)00289-6.
- 327 3. Schneider, S.H. Detecting climatic change signals: are there any "fingerprints"? *Science* **1994**, *263*, pp. 341–  
328 347, doi: 10.1126/science.263.5145.341
- 329 4. Stevens, C.M.; Rust, F.E. The carbon isotopic composition of atmospheric methane. *J. Geophys. Res.: Oceans*  
330 **1982**, *87*, pp. 4879–4882, doi: 10.1029/JC087iC07p04879.
- 331 5. Monteil, G.A.; Houweling, S.; Dlugokenky, E.J.; Maenhout, G.; Vaughn, B.H.; White, J.W.C.; Rockmann,  
332 T. Interpreting methane variations in the past two decades using measurements of  $\text{CH}_4$  mixing ratio and  
333 isotopic composition. *Atmosph. Chem. Phys.* **2011**, *11*, pp. 9141–9153, doi: 10.5194/acp-11-9141-2011.
- 334 6. Li, J.J.; Li, R.X.; Dong, H.; Wang, Z.H.; Zhao, B.S.; Wang, N.; Cheng, J.H. Carbon isotopic compositions in  
335 carbon dioxide measured by micro-laser Raman spectroscopy. *J. Appl. Spectr.* **2017**, *84*, pp. 237–241, doi:  
336 10.1007/s10812-017-0457-8.
- 337 7. Keiner, R.; Frosch, T.; Massad, T.; Trumbore, S.; Popp, J. Enhanced Raman multigas sensing—a novel tool  
338 for control and analysis of  $^{13}\text{CO}_2$  labeling experiments in environmental research. *Analyst* **2014**, *139*, pp.  
339 3879–3884, doi: 10.1039/C3AN01971C.

- 340 8. Li, J.; Li, R.; Zhao, B.; Guo, H.; Zhang, S.; Cheng, J.; Wu, X. Quantitative measurement of carbon isotopic  
341 composition in CO<sub>2</sub> gas reservoir by micro-laser Raman spectroscopy. *Spectrochim. Acta A Mol. Biomol.*  
342 *Spectrosc.* **2018**, *195*, pp. 191-198, doi: 10.1016/j.saa.2018.01.082.
- 343 9. Zhang, M.; Zhao, L.B.; Luo, W.L.; Pang, R.; Zong, C.; Zhou, J.Z.; Ren, B.; Tian, Z.Q.; Wu, D.Y. Experimental  
344 and theoretical study on isotopic surface-enhanced Raman spectroscopy for the surface catalytic coupling  
345 reaction on silver electrodes. *J. Phys. Chem. C* **2016**, *120*, pp. 11956-11965, doi: 10.1021/acs.jpcc.6b02252.
- 346 10. Prinzhofer, A.; Battani, A. Gas isotopes tracing: an important tool for hydrocarbons exploration. *Oil Gas*  
347 *Sci. Technol.* **2003**, *58*, pp. 299-311, doi: 10.2516/ogst:2003018.
- 348 11. Naik, V.; Voulgarakis, A.; Fiore, A.M.; Horowitz, L.W.; Lamarque, J.F.; Lin, M.; Prather, M.J.; Young, P.J.;  
349 Bergmann, D.; Cameron-Smith, P.J.; et al. Preindustrial to present-day changes in tropospheric hydroxyl  
350 radical and methane lifetime from the Atmospheric Chemistry and Climate Model Intercomparison Project  
351 (ACCMIP). *Atmosph. Chem. Phys.* **2013**, *13*, pp. 5277-5298, doi: 10.5194/acp-13-5277-2013.
- 352 12. Bergamaschi, P.; Schupp, M.; Harris, G.W. High-precision direct measurements of <sup>13</sup>CH<sub>4</sub>/<sup>12</sup>CH<sub>4</sub> and  
353 <sup>12</sup>CH<sub>3</sub>D/<sup>12</sup>CH<sub>4</sub> ratios in atmospheric methane sources by means of a long-path tunable diode laser  
354 absorption spectrometer. *App. Opt.* **1994**, *33*, pp. 7704-7716, doi: 10.1364/AO.33.007704.
- 355 13. Bréas, O.; Guillou, C.; Reniero, F.; Wada, E. The global methane cycle: isotopes and mixing ratios, sources  
356 and sinks. *Isot. Environ. Health S.* **2001**, *37*, pp. 257-379, doi: 10.1080/10256010108033302.
- 357 14. Petrov, D.V.; Matrosov, I.I. Raman gas analyzer (RGA): Natural gas measurements. *Appl. Spectr.* **2016**, *70*,  
358 1770-1776, doi: 10.1177/0003702816644611.
- 359 15. Prokhorov, I.; Kluge, T.; Janssen, C. A novel method of carbon dioxide clumped isotope analysis with  
360 tunable infra-red laser direct absorption spectroscopy. *EGUGA* **2016**, p. EPSC2016-3931, doi:  
361 2016EGUGA..18.3931P.
- 362 16. Polyansky, O.L.; Bielska, K.; Ghysels, M.; Lodi, L.; Zobov, N.F.; Hodges, J.T.; Tennyson, J. High-accuracy  
363 CO<sub>2</sub> line intensities determined from theory and experiment. *Phys. Rev. Lett.* **2015**, *114*, p. 243001, doi:  
364 10.1103/PhysRevLett.114.243001.
- 365 17. International Committee for Weights and Measures. Proceedings of Session I of the 104<sup>th</sup> meeting (9-10  
366 March 2015). Available online: <https://www.bipm.org/utis/en/pdf/CIPM/CIPM2015-I-EN.pdf> (accessed on  
367 29 August 2020).
- 368 18. van Geldern, R.; Nowak, M.E.; Zimmer, M.; Szzybalski, A.; Myrtilinen, A.; Barth, J.A.; Jost, H.J. Field-based  
369 stable isotope analysis of carbon dioxide by mid-infrared laser spectroscopy for carbon capture and storage  
370 monitoring. *Anal. Chem.* **2014**, *86*, pp. 12191-12198, doi: 10.1021/ac5031732.
- 371 19. Siberio-Pérez, D.Y.; Wong-Foy, A.G.; Yaghi, O.M.; Matzger, A.J. Raman spectroscopic investigation of CH<sub>4</sub>  
372 and N<sub>2</sub> adsorption in metal-organic frameworks. *Chem. Mater.* **2007**, *19*, pp. 3681-3685, doi:  
373 10.1021/cm070542g.
- 374 20. Keutel, D.; Seifert, F.; Oehme, K.L.; Asenbaum, A.; Musso, M. Evidence for negative cross correlations in  
375 vibrational dephasing in liquids: Isotropic Raman-line shift and width phenomena in isotopic mixtures of  
376 N<sub>2</sub> and O<sub>2</sub>. *Phys. Rev. Lett.* **2000**, *85*, p. 3850, doi: 10.1103/PhysRevLett.85.3850.
- 377 21. Cabaço, M.I.; Longelin, S.; Danten, Y.; Besnard, M. Transient dimer formation in supercritical carbon  
378 dioxide as seen from Raman scattering. *J. Chem. Phys.* **2008**, *128*, p. 074507, doi: 10.1063/1.2833493.
- 379 22. Musso, M.; Matthai, F.; Keutel, D.; Oehme, K.L. Critical Raman line shape behavior of fluid nitrogen. *Pure*  
380 *Appl. Chem.* **2004**, *76*, pp. 147-155, doi: 10.1351/pac200476010147.
- 381 23. Yan, D.; Popp, J.; Frosch, T. Analysis of fiber-enhanced Raman gas sensing based on Raman chemical  
382 imaging. *Anal. Chem.* **2017**, *89*, pp. 12269-12275, doi: 10.1021/acs.analchem.7b03209.
- 383 24. Yu, A.; Zuo, D.; Wang, X. Optimization of parabolic cell for gas Raman analysis. *J. Raman Spectr.* **2019**, *50*,  
384 pp. 731-740, doi: 10.1002/jrs.5564.
- 385 25. Eichmann, S.C.; Weschta, M.; Kiefer, J.; Seeger, T.; Leipertz, A. Characterization of a fast gas analyzer based  
386 on Raman scattering for the analysis of synthesis gas. *Rev. Sci. Instrum.* **2010**, *81*, p. 125104, doi:  
387 10.1063/1.3521397.
- 388 26. Petrak, B.; Cooper, J.; Konthasinghe, K.; Peiris, M.; Djeu, N.; Hopkins, A.J.; Muller, A. Isotopic gas analysis  
389 through Purcell cavity enhanced Raman scattering. *Appl. Phys. Lett.* **2016**, *108*, p. 091107, doi:  
390 10.1063/1.4943146.
- 391 27. Sharma, R.; Poonacha, S.; Bekal, A.; Vartak, S.; Weling, A.; Tilak, V.; Mitra, C. Raman analyzer for sensitive  
392 natural gas composition analysis. *Opt. Eng.* **2016**, *55*, p. 104103, doi: 10.1117/1.OE.55.10.104103.

- 393 28. John, S.T.; Shaw, D.M.; Klug, D.D.; Patchkovskii, S.; Vankó, G.; Monaco, G.; Krisch, M. X-ray Raman  
394 spectroscopic study of water in the condensed phases. *Phys. Rev. Lett.* **2008**, *100*, p. 095502, doi:  
395 10.1103/PhysRevLett.100.095502.
- 396 29. Chubchenko, Y.K.; Konopel'ko, L.A. Development of a new type of reference standard for carbon isotopic  
397 composition. *Measur. Tech.* **2018**, *60*, pp. 1228-1232, doi: 10.1007/s11018-018-1344-2.
- 398 30. Vitkin, V.V.; Chubchenko, I.K.; Polischuk, A.V.; Kovalev, A.V.; Popov, E.E. Raman gas analyzer for  
399 detecting carbon isotopologues. *J. Physics: Conf. Ser.* **2019**, *1399*, p. 022033, doi: 10.1088/1742-  
400 6596/1399/2/022033.
- 401 31. Popov, E.; Polishchuk, A.; Grigorenko, K.; Chubchenko, I.; Vitkin, V. Raman detector of carbon isotopes.  
402 *Opt. Sens. and Det. VI* **2020**, *11354*, p. 113542P, doi: 10.1117/12.2556262
- 403 32. ASTM E1840-96, Standard Guide for Raman Shift Standards for Spectrometer Calibration; ASTM  
404 International: West Conshohocken, PA, USA, 1996.
- 405 33. Howard-Lock, H.E.; Stoicheff, B.P. Raman intensity measurements of the Fermi diad  $\nu_1, 2\nu_2$  in  $^{12}\text{CO}_2$  and  
406  $^{13}\text{CO}_2$ . *J. Molec. Spectr.* **1971**, *37*, pp. 321-326, doi: 10.1016/0022-2852(71)90302-X.
- 407 34. Niederer, H.M.; Wang, X.G.; Carrington T., Jr.; Albert, S.; Bauerecker, S.; Boudon, V.; Quack, M. Analysis  
408 of the rovibrational spectrum of  $^{13}\text{CH}_4$  in the Octad range. *J. Molec. Spectr.* **2013**, *291*, pp. 33-47, doi:  
409 10.1016/j.jms.2013.06.003.
- 410 35. Niederer, H.M.; Albert, S.; Bauerecker, S.; Boudon, V.; Champion, J.P.; Quack, M. Global analysis of the  
411 infrared spectrum of  $^{13}\text{CH}_4$ : lines in the region 0 to  $3200\text{ cm}^{-1}$ . *CHIMIA Intern. J. Chem.* **2008**, *62*, pp. 273-276,  
412 doi: 10.2533/chimia.2008.273.
- 413 36. Boudon, V.; Rey, M.; Loete, M. The vibrational levels of methane obtained from analyses of high-resolution  
414 spectra. *J. Quant. Spectr. Rad. Transf.* **2006**, *98*, pp. 394-404, doi: 10.1016/j.jqsrt.2005.06.003.
- 415 37. Gooijer, C.; Ariese, F.; Hofstraat, J.W. *Chemical Analysis: A Series of Monographs on Analytical Chemistry and*  
416 *Its Application*; John Wiley & Sons: New York, NY, USA, 2000.
- 417 38. Okita, Y.; Katagiri, T.; Matsuura, Y. A Raman cell based on hollow optical fibers for breath analysis. In  
418 *Optical Fibers and Sensors for Medical Diagnostics and Treatment Applications X*, San Francisco, CA, USA,  
419 24 February 2010; Publisher: International Society for Optics and Photonics, Vol. 7559, p. 755908, doi:  
420 10.1117/12.841414.
- 421 39. Butz, D.E.; Cook, M.E.; Eghbalian, H.R.; Assadi-Porter, F.; Porter, W.P. Changes in the natural abundance  
422 of  $^{13}\text{CO}_2/^{12}\text{CO}_2$  in breath due to lipopolysacchride-induced acute phase response. *Rapid Commun. Mass*  
423 *Spectr.* **2009**, *23*, pp. 3729-3735, doi: 10.1002/rcm.4310.
- 424 40. Braden, B.; Haisch, M.; Duan, L.P.; Lembcke, B.; Caspary, W.F.; Hering, P. Clinically feasible stable isotope  
425 technique at a reasonable price: analysis of  $^{13}\text{CO}_2/^{12}\text{CO}_2$ -abundance in breath samples with a new isotope  
426 selective-nondispersive infrared spectrometer. *Z. Gastroenterol.* **1994**, *32*, pp. 675-678.
- 427 41. Barth, E.; Tugtekin, I.; Weidenbach, H.; Wachter, U.; Vogt, J.; Radermacher, P.; Adler, G.; Georgieff, M.  
428 Determination of  $^{13}\text{CO}_2/^{12}\text{CO}_2$  ratio by IRMS and NDIRS. *Isot. Environ. Health S.* **1998**, *34*, pp. 209-213, doi:  
429 10.1080/10256019708036348.
- 430 42. Koletzko, S.; Koletzko, B.; Haisch, M.; Hering, P.; Seeboth, I.; Hengels, K.; Braden, B. Isotope-selective non-  
431 dispersive infrared spectrometry for detection of *Helicobacter pylori* infection with  $^{13}\text{C}$ -urea breath test.  
432 *The Lancet* **1995**, *345*, pp. 961-962, doi: 10.1016/S0140-6736(95)90704-1.
- 433 43. Normand, S.; Pachiaudi, C.; Khalfallah, Y.; Guilluy, R.; Mornex, R.; Riou, J. P.  $^{13}\text{C}$  appearance in plasma  
434 glucose and breath  $\text{CO}_2$  during feeding with naturally  $^{13}\text{C}$ -enriched starchy food in normal humans. *Am. J.*  
435 *Clin. Nutr.* **1992**, *55*, pp. 430-435, doi: 10.1093/ajcn/55.2.430.
- 436 44. Schoeller, D.A.; Brown, C.; Nakamura, K.; Nakagawa, A.; Mazzeo, R.S.; Brooks, G.A.; Budinger, T. F.  
437 Influence of metabolic fuel on the  $^{13}\text{C}/^{12}\text{C}$  ratio of breath  $\text{CO}_2$ . *Biomed. Mass Spectrom.* **1984**, *11*, pp. 557-561,  
438 doi: 10.1002/bms.1200111103.
- 439



© 2020 by the authors. Submitted for possible open access publication under the terms and conditions of the Creative Commons Attribution (CC BY) license (<http://creativecommons.org/licenses/by/4.0/>).