



HAL
open science

Experimental Investigation of a Combined Drilling and Thread Milling Process: Thrilling

Anna Carla Araujo, M B G Jun, S G Kapoor, R E Devor

► **To cite this version:**

Anna Carla Araujo, M B G Jun, S G Kapoor, R E Devor. Experimental Investigation of a Combined Drilling and Thread Milling Process: Thrilling. Thirty-Fifth North American Manufacturing Research Conference - NAMRC 35, 2007, Ann Harbor - Michigan, United States. hal-03212832

HAL Id: hal-03212832

<https://hal.science/hal-03212832>

Submitted on 30 Apr 2021

HAL is a multi-disciplinary open access archive for the deposit and dissemination of scientific research documents, whether they are published or not. The documents may come from teaching and research institutions in France or abroad, or from public or private research centers.

L'archive ouverte pluridisciplinaire **HAL**, est destinée au dépôt et à la diffusion de documents scientifiques de niveau recherche, publiés ou non, émanant des établissements d'enseignement et de recherche français ou étrangers, des laboratoires publics ou privés.

EXPERIMENTAL INVESTIGATION OF A THRILLING PROCESS

A. C. Araujo
Mechanical Engineering Department
Universidade Federal do Rio de Janeiro
Rio de Janeiro, RJ, Brazil

M. B. G. Jun, S. G. Kapoor, and R. E. DeVor
Department of Mechanical Science and Engineering
University of Illinois at Urbana-Champaign
Urbana, IL 61801

KEYWORDS

Drilling, thread milling, thrilling, cutting force, thread quality.

ABSTRACT

This paper investigates a new thread making process called thrilling, which performs both drilling and thread milling with one tool. A simplified linear thread milling operation is performed to understand the forces associated with thread milling and number of engaged threads. Thrilling experiments are conducted to examine the process and associated forces. The forces measured during thrilling are compared to tapping results for the same size threads. The results show that forces in thrilling are significantly lower than those in tapping. The effects of both drilling and thread milling and their interaction on the thread quality have also been investigated.

INTRODUCTION

Threads on a workpiece can be produced in a variety of ways based on two basic principles: plastic working and metal cutting. Threads made by plastic working are stronger but lack the accuracy required for many applications. Threads made by cutting on the other hand provide better accuracy and finish, and threads can be made even with brittle materials. There are two common cutting processes for internal

thread generation, which are cut tapping and thread milling [Stephenson and Agapiou, 1996]. Recently, a thread cutting tool called thriller has been developed by Emuge Corp., which can perform both drilling and thread cutting operations. Thus, after drilling a hole, no tool change is required to make threads, leading rapid thread generation. This process needs to be understood for effective application of the process.

The thrilling process combines the drilling and thread milling processes. Thus, the bottom of a thriller is similar to a drill, and along the helix of the tool has the tool geometry of a thread milling tool. Since one tool performs two different processes consecutively, the quality of the threads generated would depend on both drilling and thread milling operations. However, though thread making processes both based on plastic working [Cao and Sutherland, 2002, Ivanina, 2005, Warrington et al., 2005] and thread cutting [Araujo et al., 2006, Smith, 1989] have been extensively studied by many researchers, the thrilling has not been investigated at all. Also, very little is known about cutting characteristics of the thrilling process.

The objective this paper is to investigate the thrilling process. Cutting forces during thrilling are measured and related to the cutting characteristics of the process. The quality of the threads generated at different drilling and thread milling conditions is examined to understand the

relationship between drilling and thread milling operations as one affects the other. Two different workpiece materials are considered to investigate the effect of workpiece materials.

The paper is organized as follows. The unique characteristics of the thrilling process are first described, followed by examination of the tool geometry. Then, the cutting characteristics during both drilling and thread milling are presented, followed by study on the quality of the threads generated.

DESCRIPTION OF A THRILLING PROCESS

The machining process of thrilling can be divided into seven stages as shown in Fig. 1. The first stage involves positioning the tool above the workpiece where the hole with threads needs to be made. Once the tool is positioned, it drills down into the workpiece to the desired depth of the hole. Then, the tool retracts up one third of the pitch. In order to make the thread, while rotating at the prescribed rotational speed and retracting the tool half the pitch, the tool moves radially into the workpiece to a proper radial depth of cut through a helical "run-in loop". Once the cutting edge is engaged into the workpiece at the desired radial depth of cut, the tool is moved up helically for one complete revolution. The number of threads generated in this one revolution corresponds to the number threads engaged in the workpiece. If generation of the threads for the full depth of the

hole is achieved in several steps, the stages 4-6 are repeated until all the threads are generated. Then, the tool moves back to the center of the hole, and, finally, the tool is retracted out of the hole.

During the seven stages, major cutting occurs at stages 2 (drilling operation) and 6 (thread milling operation). The drilling operation affects the quality of the hole, which in turn affects the thread milling process. Since both of these operations influence the whole process, their interaction may play a role in determining the final thread quality.

THRILLING TOOL GEOMETRY

The geometry of a thriller is shown in Fig. 2. Each flute has a chisel edge, drilling cutting lip, milling cutting edge, and thread milling cutting edge. The chisel edge does not cut but only spread the material sideways by an indentation mechanism [Altintas, 2000]. It has a width of $2w$ and an edge angle of ψ_c . The cutting lips have an offset from the center of the tool due to the chisel edge. The cutting lips remove the material with a constant chip thickness and the tool is fed into the workpiece at a feedrate of f_d . The chisel edge and cutting lips have the shape of a drill. The cutting lips at the point angle κ and with the height h_d meet with the milling cutting edge. The height of the milling cutting edge is denoted as h_e . The cutting tips, though, do not interfere with the thread milling operation.

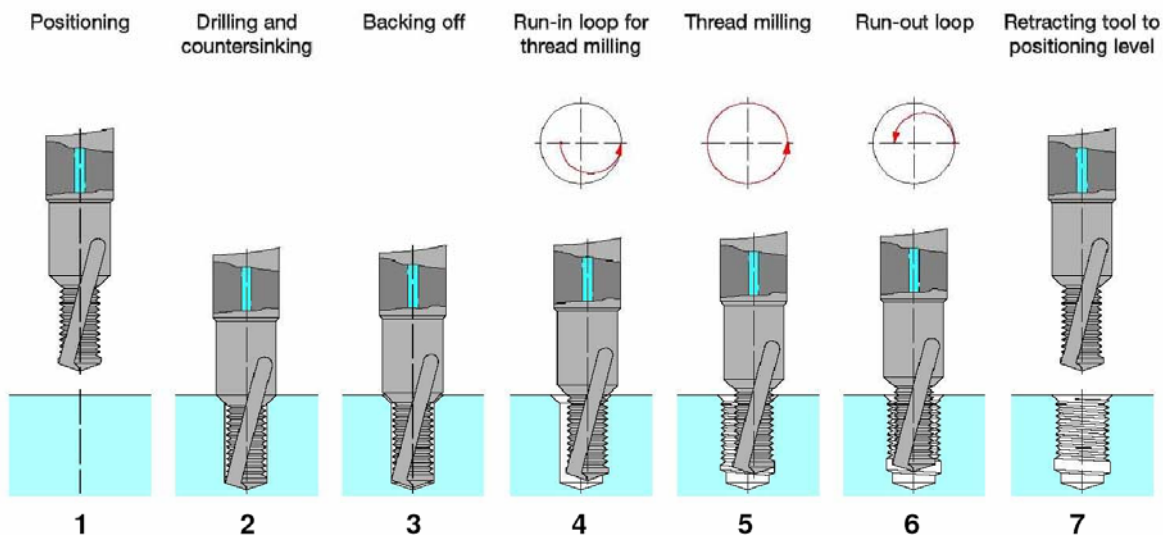

FIGURE 1. A THRILLING PROCESS

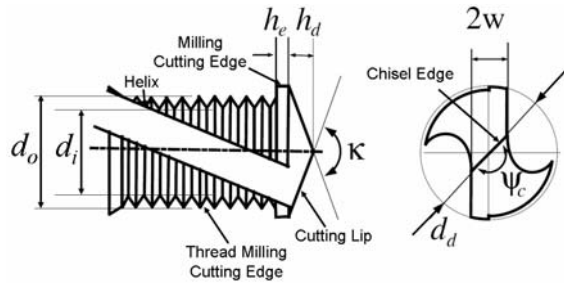

FIGURE 2. A THRILLING TOOL GEOMETRY

The milling cutting edge separates the drilling part from the thread milling part. In the drilling stage, it does not cut but only acts as a helical flute as in drilling during the drilling operation. Then, the milling cutting edge cuts as a milling tool so that the cutting lips do not interfere with the thread milling operation and allow the thread milling operation. During the thread milling operation, the cutting forces generated include the forces due to thread making and also cutting by this milling cutting edge. The external diameter of the thread milling cutting edge is smaller than the milling cutting edge diameter.

The threads on a thriller have the maximum diameter on the outside d_o and minimum diameter d_i , which can be obtained as $d_i = d_o - 2h_t$, where h_t is the thread height. The thread pitch is denoted as p . Figure 3 shows an example of the thread geometry of an M10 thriller tool. The dashed line shows the height of a M10 thread. Since the drilled hole needs to be greater than the thriller thread diameter, the milling cutting edge height or radius is greater than the thread tooth height or radius. To make an M10 thread in the workpiece, the distance to be moved into the workpiece during the thread milling operation is equal to the thread height plus the difference between heights of the milling cutting edge and thread tooth. For the thriller in Fig. 3, this distance is equal to 0.9 mm.

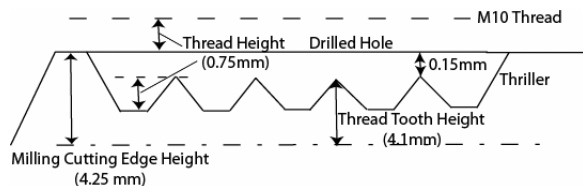

FIGURE 3. THRILLER THREAD GEOMETRY

EXPERIMENTAL SETUP

Figure 4 shows the experimental setup for thrilling operations. Experiments were conducted on Mori Seiki TV30 CNC milling center. A Kistler

four-axis dynamometer (9272) was used to measure both drilling and thread milling forces. LabView software was used for data acquisition. The experiments were conducted with an Emuge thriller of size M10x1.5 standard threads. Two different workpieces (Brass and Al6061) were used for the experiments. Castrol 6519 at 5% dilution was used as cutting fluid. The quality of the threads was analyzed using Mitutoyo Contracer CBH-400. The helix angle was measured using an optical microscope (Hirox CX-10C) and TechDig software (Fig. 5). Table 1 shows the thriller geometry.

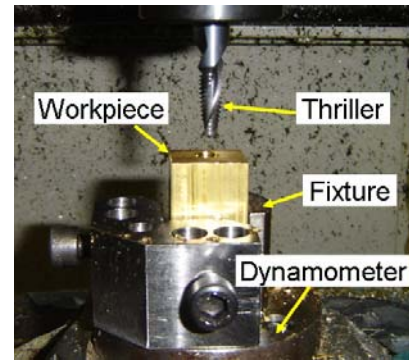

FIGURE 4. EXPERIMENTAL SETUP

TABLE 1. THRILLER GEOMETRY

Geometry	Value
Point angle κ	140°
Cutting lips height h_d	1.64 mm
Milling cutting edge height h_e	1.35 mm
Milling cutting edge diameter d_d	8.5 mm
Helix angle α_h	28°
Thread pitch p	1.5 mm
Thread height h_t	0.75 mm
Thread outside diameter d_o	8.2 mm
Thread inside diameter d_i	5.2 mm

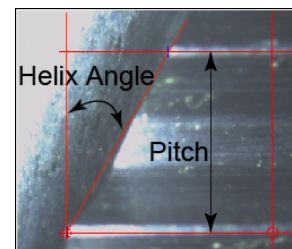

FIGURE 5. HELIX ANGLE MEASUREMENT

THRILLING FORCE EXPERIMENTS

Linear Thread Milling Experiments

In order to study the force characteristics of the thrilling process, experiments were first

conducted by simplifying the thread milling operation as shown in Fig. 6. By rolling out straight the curvilinear tool-workpiece path in Fig. 6(a) and neglecting the motion in the z-direction, the thread milling operation can be simplified as in Fig. 6(b) such that the tool moves linearly in the x-direction similar to a milling process. This simplification is a good approximation of the process as the z-direction velocity is very small compared to the cutting velocity and the radius of the curvature of the hole is large compared to the chip thickness. This simplification allows more thorough examination of the force profiles and the effects of the number of pitches engaged. The only major difference with this simplification is that the cutting flue exits the workpiece sooner than in actual thread milling operation [Araujo et al., 2006].

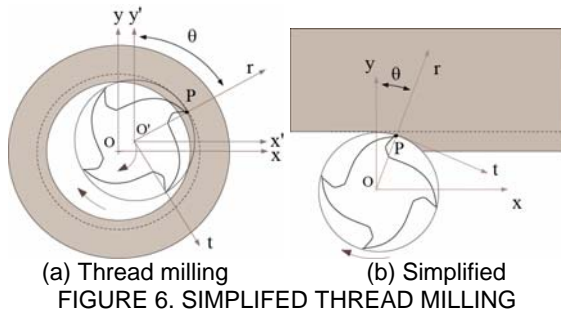

In order to see the effect of number of threads engaged, linear thread milling experiments were conducted at different axial depth of cuts (2.9 – 10.4 mm) with brass workpiece. Initially, experiments were conducted with only the milling cutting edge and no thread engaged. Then, experiments were conducted with increasing number of threads engaged. Figure 7 shows the peak and average forces averaged over 100 revolutions during linear thread milling experiments, plotted against the number of threads engaged. “Zero” thread engaged means that only the milling cutting edge was engaged. It shows that the force in the normal-to-feed direction is the highest. Also, as the number of engaged threads increases, the force in the normal-to-feed direction increases much more than in the feed direction. In actual threading operations, the feed direction represents the tangential direction. Thus, increase in the number of engaged threads would result in small increase in the torque, leading to less torque requirements. However, the radial forces would be high, which may result in more tool deflections.

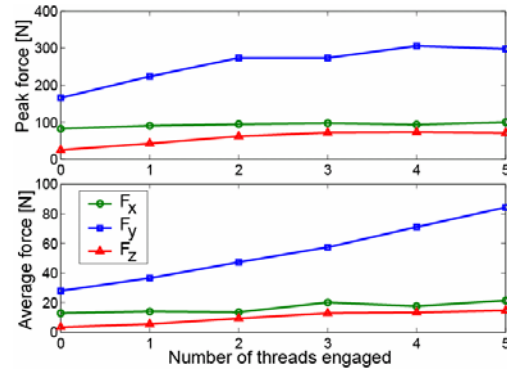

FIGURE 7. MEASURED FORCES DURING LINEAR THREAD MILLING

Because of the helix angle and small radial depth of cut, though the average force increases linearly with the number of threads engaged, the peak force does not. Figure 8 shows the force profiles with (a) 0, (b) 1, (c) 3, and (d) 5 threads engaged. As shown, though peak force does not increase as much, the area under the profile is larger with increased number of threads engaged, resulting in increased average forces. Also, similar to the results in [Araujo et al., 2006], the number of engaged threads cause the force profiles to have “local” peaks. In Fig. 8(d), due to increased number of engaged threads, there is an increased number of these local peaks on the force signature. These local peaks lead to forces with higher exciting frequencies than the tooth passing frequency, which can have a dynamic effect on tool vibrations.

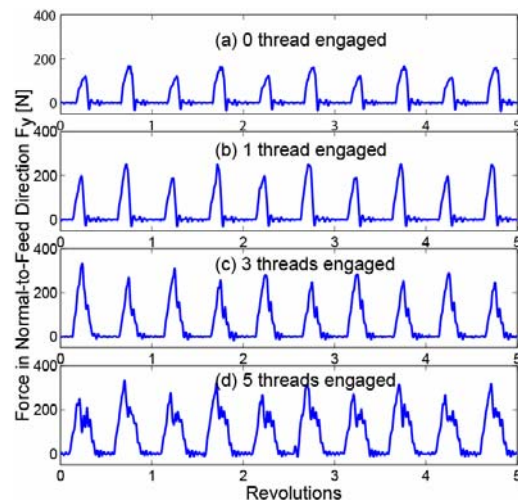

FIGURE 8. FORCE PROFILES DURING LINEAR THREAD MILLING

Threading Experiments

In order to study the force characteristics during actual thrilling operations, experiments were conducted for two different workpiece materials (brass and Al6061). Table 2 shows the cutting conditions. In order to evaluate the effectiveness of the thrilling process, the thread milling forces were compared to the tapping results given in [Chowdhary et al., 2003] for the same workpiece materials.

TABLE 2. CUTTING CONDITIONS FOR FORCE EXPERIMENTS

Exp. #	Drilling		Thread Milling	
	Speed (rpm)	Feed (mm/rev)	Speed (rpm)	Feed (mm/rev)
1	1000	0.05	1000	0.01
2	1000	0.15	1000	0.02
3	2000	0.05	2000	0.01
4	2000	0.15	2000	0.02

Figure 9 shows the torque and thrust during the thread milling operation at the spindle speed of 1000 rpm and the feedrate of 0.02 mm/rev. The forces during the run-in loop, thread milling, and run-out loop are also shown in Fig. 9. An example of the tapping torque and thrust at the spindle speed of 1000 rpm for the same size tool is shown in Fig. 10. Unlike the tapping torque and thrust, thread milling torque and thrust have periodic components, which could cause torsional and axial tool vibrations. Since radial forces are higher than tangential force in thread milling, the forces in the x- and y-directions are quite large also with the periodic components as shown in Fig. 11, which could cause lateral deflections. However, if maximum values of torque and thrust are taken during the thread milling operation, however, comparison of the magnitudes shown in Table 3 show that thread milling torque and thrust are, for most cases, more than ten times smaller than tapping results given in [Chowdhary et al., 2003]. In tapping, the feedrate is determined by the spindle speed and the thread pitch. However, in thread milling, the feedrate can be any value, which is the reason why the thread milling forces in Table 3 are much lower than tapping forces and can be lower if desired by using lower feedrates. This freedom to select a desired feedrate allows the thrilling or thread milling process more versatile.

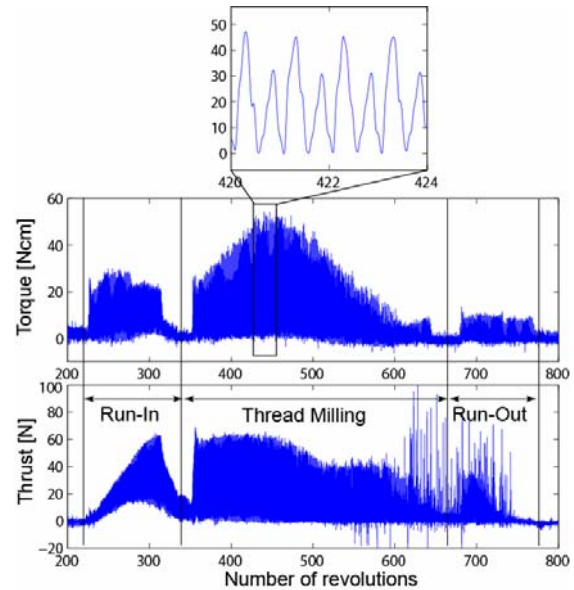

FIGURE 9. TYPICAL THREAD MILLING TORQUE AND THRUST

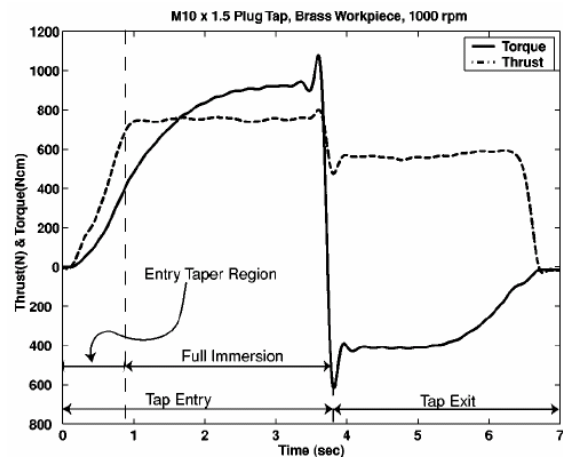

FIGURE 10. TYPICAL TAPPING TORQUE AND THRUST

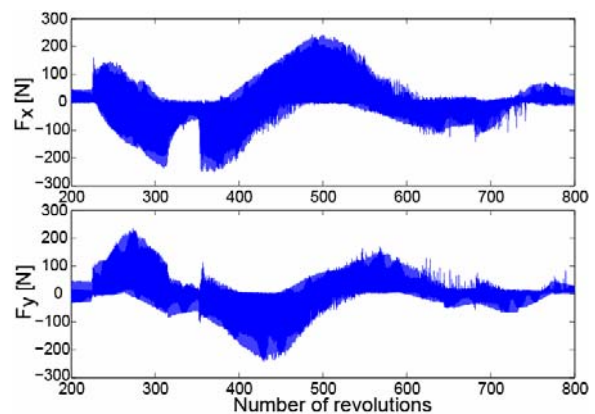

FIGURE 11. THREAD MILLING FORCES IN X- AND Y-DIRECTIONS

TABLE 3. COMPARISON OF THREAD MILLING AND TAPPING TORQUE AND THRUST

Thread Milling				
Exp. #	Brass		Al6061	
	Torque [Ncm]	Thrust [N]	Torque [Ncm]	Thrust [N]
1	44.4	60.7	45.4	59.4
2	52.9	70.3	65.2	86.2
3	43.3	58.9	42.3	51.1
4	54.9	69.7	65.4	99.7
Tapping				
Plug	925	760	1049	766
Bottom	832	984	913	857

THREAD QUALITY EXPERIMENTS

In order to investigate the effect of both drilling and thread milling and their interaction on the thread quality, two levels of spindle speed (1000 and 2000 rpm) and feedrate (0.05 and 0.15 mm/rev for drilling and 0.01 and 0.02 mm/rev for thread milling) for both drilling and thread milling operations are considered. Two different workpiece materials (brass and Al6061) were considered. Table 4 shows the experimental design.

TABLE 4. EXPERIMENTAL DESIGN

Exp. #	Drilling		Thread Milling	
	Speed (rpm)	Feed (mm/rev)	Speed (rpm)	Feed (mm/rev)
1	2000	0.15	2000	0.02
2	1000	0.15	2000	0.02
3	2000	0.05	2000	0.02
4	1000	0.05	2000	0.02
5	2000	0.15	1000	0.02
6	1000	0.15	1000	0.02
7	2000	0.05	1000	0.02
8	1000	0.05	1000	0.02
9	2000	0.15	2000	0.01
10	1000	0.15	2000	0.01
11	2000	0.05	2000	0.01
12	1000	0.05	2000	0.01
13	2000	0.15	1000	0.01
14	1000	0.15	1000	0.01
15	2000	0.05	1000	0.01
16	1000	0.05	1000	0.01

The thread quality was evaluated in terms of the thread geometry (pitch and height). In order to measure the thread pitch and height, the block with the threaded hole was cut in half as shown in Fig. 12(a). Then a profilometer (Mitutoyo Contracer CBH-1400) was used to scan along the direction as shown in Fig. 12(b).

The measurements were taken by moving the stylus of the profilometer at a rate of 0.5 mm/s. An example of the profilometer measurement is shown in Fig. 13. The thread pitch and height were measured to be the distances as shown in Fig. 13.

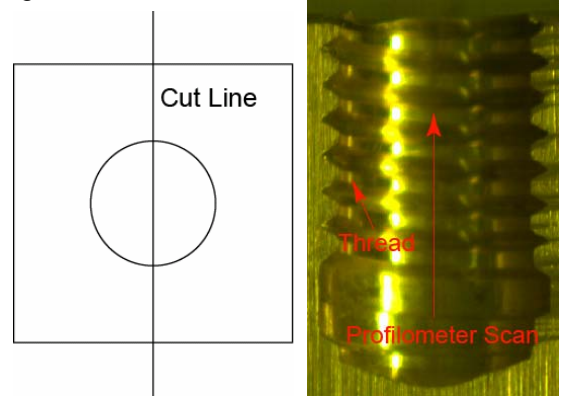

(a) Cross-section cut (b) Thread measurement
FIGURE 12. THREAD QUALITY MEASUREMENT

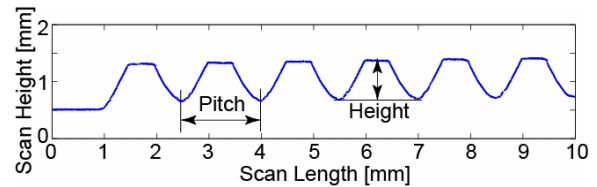

FIGURE 13. PROFILOMETER MEASUREMENT

A total of four scans were taken for each block to measure the thread pitch and height. Two scans were first taken on one half of the block, and two other scans were then performed on the other half of the block. For each scan, five threads were scanned starting from the bottom of the hole, and the heights and pitches of these five threads were averaged. Then, the average of the four scan results were recorded as the thread geometry for each experiment. Table 5 shows the results of the thread geometry measurements.

TABLE 5. THREAD MEASUREMENT RESULTS

Exp. #	Brass		Al6061	
	Height (mm)	Pitch (mm)	Height (mm)	Pitch (mm)
1	0.691	1.494	0.707	1.511
2	0.674	1.509	0.738	1.506
3	0.714	1.509	0.751	1.503
4	0.736	1.507	0.738	1.504
5	0.719	1.496	0.750	1.506
6	0.746	1.525	0.744	1.507
7	0.679	1.494	0.744	1.507
8	0.741	1.503	0.734	1.550
9	0.722	1.508	0.754	1.511

10	0.777	1.493	0.741	1.500
11	0.748	1.507	0.745	1.505
12	0.747	1.501	0.739	1.502
13	0.759	1.499	0.763	1.507
14	0.753	1.514	0.755	1.503
15	0.773	1.504	0.740	1.496
16	0.753	1.506	0.752	1.506
Average	0.733	1.504	0.743	1.508
Range	0.103	0.032	0.056	0.054

Table 5 shows that though the thread pitch is quite close to the nominal value (1.5 mm), the thread height is generally smaller than the nominal value (0.75 mm). This may be due to tool deflection caused by the radial or lateral forces during the thread milling operations. In fact, depending on the location of the thread in the hole, the thread height varies. Figure 14 shows the thread heights measured for one of the scans for the Exp. 1 hole. Low thread number on the abscissa indicates the thread near the bottom of the hole. As seen, the thread height increases close to the nominal value as the thread number increases. This indicates the presence of the lateral tool deflection due to radial forces. Note that though forces for Al6061 were generally higher as was shown in Table 3, the thread heights are lower for brass in Table 5. This may be due to the discontinuous nature of the brass chips. It was observed during the experiments that because brass chips are discontinuous, chip evacuation was difficult during the drilling operation and many segments of chips were left in the hole, which may adversely affect the thread milling operation.

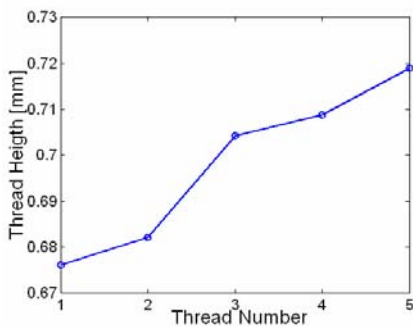

FIGURE 14. PROFILOMETER MEASUREMENT

In order to study the effects of both drilling and thread milling conditions, four effects considered are listed in Table 6 along with the low and high values. The four main effects and their interactions are analyzed. Figure 15 shows the normal probability plot for thread height of brass material. As shown, the effect of the thread milling feedrate on thread height is surely

significant. The similar result is observed with Al6061. This is somewhat expected since increase in the thread milling feedrate directly increases the cutting forces. Figure 16 shows the main effects on thread height for brass. It shows clear effects of thread milling feedrate, and increasing the thread milling feedrate decreases the thread height away from the nominal value.

TABLE 6. CONSIDERED EFFECTS

	Variable	Low (1)	High (2)
A	Drill speed	1000	2000
B	Drill feed	0.05	0.15
C	Thread milling speed	1000	2000
D	Thread milling feed	0.01	0.02

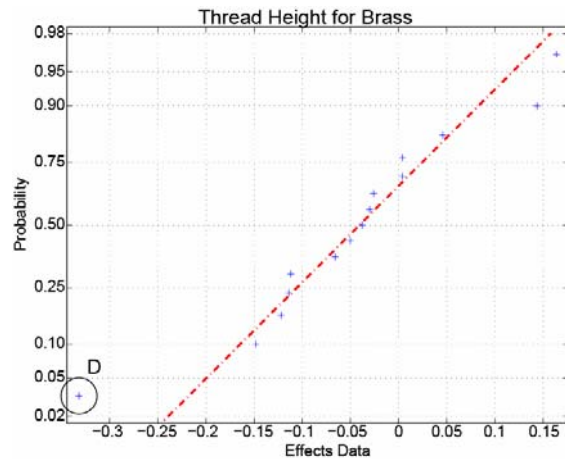

FIGURE 15. NORMAL PROBABILITY PLOT OF EFFECTS ON THREAD HEIGHT FOR BRASS

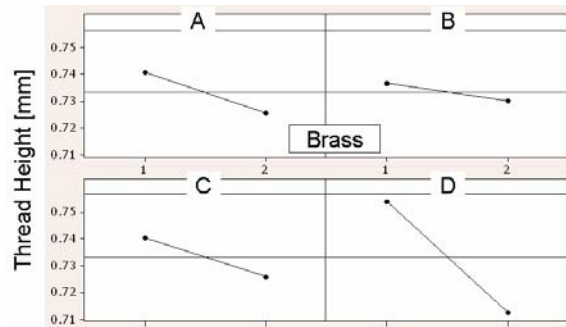

FIGURE 16. MAIN EFFECTS ON THREAD HEIGHT FOR BRASS

For the thread pitch, it seems that the interactions between drilling spindle speed and the thread milling conditions have significant effects (Fig. 17). The fact that the drilling spindle speed has an interaction effect indicates that the pitch geometry depends on the drilled hole conditions. Figure 18 shows the main effects on

thread pitch for brass. It shows that the effect of drilling spindle speed is significant and increasing the drilling spindle speed improves the thread pitch dimension. The thread milling spindle speed have a similar effect. This may be due to softening of the materials during drilling resulting in lower forces and better hole quality.

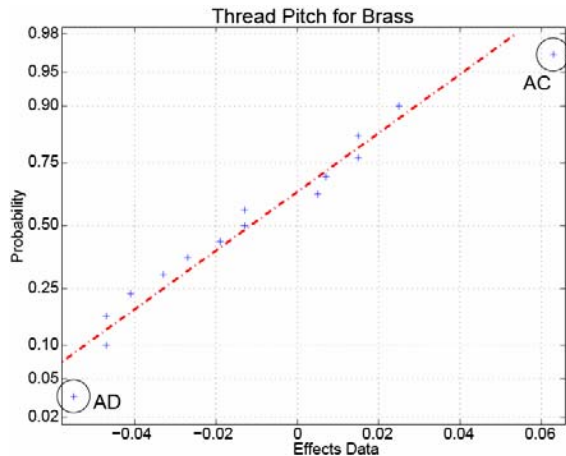

FIGURE 17. NORMAL PROBABILITY PLOT OF EFFECTS ON THREAD PITCH FOR BRASS

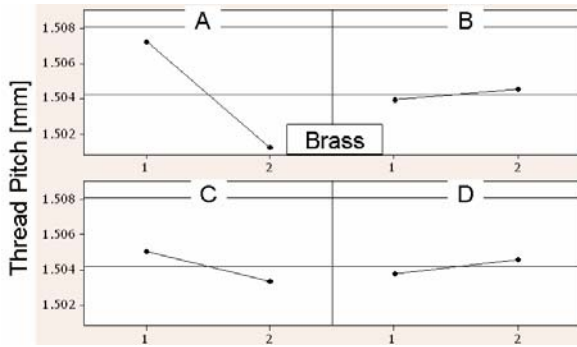

FIGURE 18. MAIN EFFECTS ON THREAD PITCH FOR BRASS

CONCLUSIONS

The following conclusions can be drawn from the experiments conducted:

1. As the number of engaged threads increases, the force in the feed (tangential) direction increases much less than in the normal-to-feed (radial) direction, leading to less torque requirement.
2. Due to helix angle, though the peak force does not increase as much, the area under the profile is larger with increased number of threads engaged, resulting in increased average forces.

3. Compared to tapping torque and thrust for the same size threads, thread milling torque and thrust are much lower (more than ten times).
4. In tapping, the feedrate is fixed by the thread pitch and the spindle speed. However, in thread milling, any feedrate can be selected, allowing either higher productivity with high feedrates or lower forces with low feedrates.
5. The thread milling feedrate has a significant effect on the thread height due to tool deflections.
6. Drilling spindle speed has a positive effect on the thread pitch. This may be due to softening of materials resulting in lower forces and better hole quality. This indicates that the pitch dimension depends more on the drilled hole conditions.

REFERENCES

- Altintas, Y. (2000), *Manufacturing automation: Metal cutting mechanics, machine tool vibrations, and CNC design*, Cambridge University Press, Cambridge.
- Araujo, A.C., Silveira, J.S., Jun, M.B.G., Kapoor, S.G., DeVor, R.E., (2006), "A model for thread milling cutting forces", *International Journal of Machine Tools & Manufacture*, Vol. 46, pp. 2057-2065.
- Cao, T., Sutherland, J.W., (2002), "Investigation of thread tapping load characteristics through mechanistics modeling and experimentation", *International Journal of Machine Tools and Manufacture*, Vol. 42, pp. 1527-1538.
- Chowdhary, S., DeVor, R.E., Kapoor, S.G., (2003), "Modeling forces including elastic recovery for internal thread forming", *Journal of Manufacturing Science and Engineering, Transactions of the ASME*, Vol. 125, pp. 681-688.
- Ivanina, I.V., (2005), "Influence of parameters of the cutting part of taps on threading accuracy", *Measurement Techniques*, Vol. 48, pp. 990-4.
- Smith, G.T., (1989), *Advanced machining: The handbook of cutting technology*, Springer/IFS Publications, UK.

Stephenson, D.A., Agapiou, J.S. (1996), *Metal cutting theory and practice*, Marcel Dekker Inc., New York.

Warrington, C., Kapoor, S.G., Devor, R.E., (2005), "Experimental investigation of thread formation in form tapping", *Journal of Manufacturing Science and Engineering, Transactions of the ASME*, Vol. 127, pp. 829-836.